

This concludes the background information.

A starting material of the present improved type, depicted in the middle and lower parts of figure, differs from prior SOI starting materials in the following ways:

- The front silicon layer is heavily doped [e.g., p⁺⁺-doped with boron], typically at a concentration of 10¹⁹ atoms/cm³ instead of being lightly doped at the conventional device concentration of 10¹⁵ atoms/cm³.
- There is a layer of thermal oxide between the front silicon layer and the BOX layer.
- The starting material is further pre-processed by growing, to an appropriate thickness, a front epitaxial silicon layer that is lightly doped (e.g., p-doped) typically at a concentration of

7×10^{14} boron atoms/cm³. This front epitaxial layer serves as the device layer in subsequent fabrication of an imager.

The advantage afforded by such an improved starting material arises from the fact that epitaxial silicon is grown at a temperature much lower than that of the anneal in the aforementioned BOX-to-handle-wafer-bonding process. Therefore, diffusion of boron away from the interface and into the device silicon is prevented. Optionally, one could perform an anneal at an intermediate temperature chosen to effect a small amount of diffusion to optimize the doping profile. Furthermore, the performance of the imager circuitry can be improved because the quality of the epitaxial silicon in the improved starting material is better than that of the float-

zone device-layer silicon in prior SOI starting materials. All of the arguments made above would remain valid for cases in which electron-donor (n) dopants were substituted for p dopants.

This work was done by Bedabrata Pain of Caltech for NASA's Jet Propulsion Laboratory. In accordance with Public Law 96-517, the contractor has elected to retain title to this invention. Inquiries concerning rights for its commercial use should be addressed to:

*Innovative Technology Assets Management
JPL*

*Mail Stop 202-233
4800 Oak Grove Drive
Pasadena, CA 91109-8099
(818) 354-2240*

E-mail: iaoffice@jpl.nasa.gov

Refer to NPO-41233, volume and number of this NASA Tech Briefs issue, and the page number.

Multi-Modulator for Bandwidth-Efficient Communication

Coding and modulation can be selected by loading configuration bits into an FPGA.

NASA's Jet Propulsion Laboratory, Pasadena, California

A modulator circuit board has recently been developed to be used in conjunction with a vector modulator to generate any of a large number of modulations for bandwidth-efficient radio transmission of digital data signals at rates that can exceed 100 Mb/s. The modulations include quadrature phase-shift keying (QPSK), offset quadrature phase-shift keying (OQPSK), Gaussian minimum-shift keying (GMSK), and octonary phase-shift keying (8PSK) with square-root raised-cosine pulse shaping. The figure is a greatly simplified block diagram showing the relationship

between the modulator board and the rest of the transmitter. The role of the modulator board is to encode the incoming data stream and to shape the resulting pulses, which are fed as inputs to the vector modulator. The combination of encoding and pulse shaping in a given application is chosen to maximize the bandwidth efficiency.

The modulator board includes gallium arsenide serial-to-parallel converters at its input end. A complementary metal oxide/semiconductor (CMOS) field-programmable gate array (FPGA) performs the coding and modulation

computations and utilizes parallel processing in doing so. The results of the parallel computation are combined and converted to pulse waveforms by use of gallium arsenide parallel-to-serial converters integrated with digital-to-analog converters. Without changing the hardware, one can configure the modulator to produce any of the designed combinations of coding and modulation by loading the appropriate bit configuration file into the FPGA.

At the time of reporting the information for this article, a prototype of the modulator board had been tested in lab-

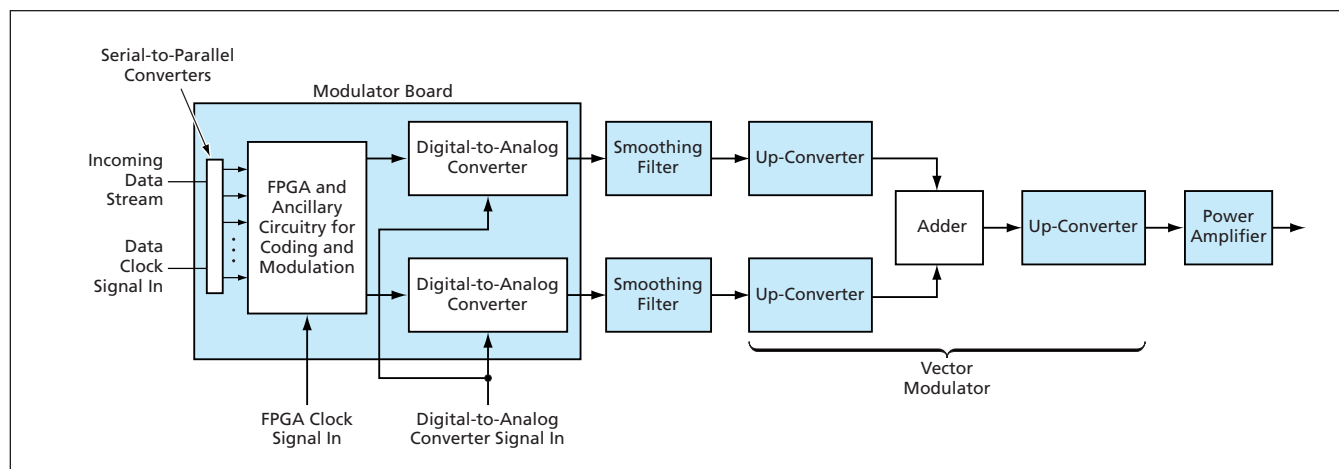

The **Modulator Board** is part of a radio transmitter, wherein it processes an incoming data stream in such a way as to generate modulator inputs for bandwidth-efficient modulation.

oratories, and tests in a two-way ground-to-spacecraft communication link were planned. Although the modulator board was conceived for original use in spacecraft-to-spacecraft and spacecraft-to-ground communications, there are potential terrestrial uses in microwave tower-to-tower links and aircraft remote sensing systems.

By making it possible to implement many different high-rate modulators in the same piece of hardware, the underlying design concepts of this modulator can be expected to afford economies of

scale: It would cost less to manufacture many identical modulator hardware units to satisfy market demands for many types of modulators than to manufacture smaller numbers of specialized modulator units having different designs.

This work was done by Andrew Gray, Dennis Lee, Norman Lay, and Craig Cheetham of Caltech; Wai Fong, Pen-Shu Yeh, Robin King, and Parminder Ghuman of Goddard Space Flight Center; and Scott Hoy and Dave Fisher of Lockheed-Martin for NASA's Jet Propulsion Laboratory. Further information is contained in a TSP (see page 1).

In accordance with Public Law 96-517, the contractor has elected to retain title to this invention. Inquiries concerning rights for its commercial use should be addressed to:

*Innovative Technology Assets Management
JPL*

*Mail Stop 202-233
4800 Oak Grove Drive
Pasadena, CA 91109-8099
(818) 354-2240*

*E-mail: iaoffice@jpl.nasa.gov
Refer to NPO-40807, volume and number of this NASA Tech Briefs issue, and the page number.*

Some Improvements in Utilization of Flash Memory Devices

Lyndon B. Johnson Space Center, Houston, Texas

Two developments improve the utilization of flash memory devices in the face of the following limitations: (1) a flash write element (page) differs in size from a flash erase element (block), (2) a block must be erased before its is rewritten, (3) lifetime of a flash memory is typically limited to about 1,000,000 erases, (4) as many as 2 percent of the blocks of a given device may fail before the expected end of its life, and (5) to ensure reliability of reading and writing, power must not be interrupted during minimum specified reading and writing times.

The first development comprises interrelated software components that regulate reading, writing, and erasure oper-

ations to minimize migration of data and unevenness in wear; perform erasures during idle times; quickly make erased blocks available for writing; detect and report failed blocks; maintain the overall state of a flash memory to satisfy real-time performance requirements; and detect and initialize a new flash memory device.

The second development is a combination of hardware and software that senses the failure of a main power supply and draws power from a capacitive storage circuit designed to hold enough energy to sustain operation until reading or writing is completed.

This work was done by Thomas K. Gender, James Chow, and William E. Ott of

Honeywell, Inc., for Johnson Space Center. For further information, contact the Johnson Commercial Technology Office at (281) 483-3809.

Title to this invention has been waived under the provisions of the National Aeronautics and Space Act {42 U.S.C. 2457(f)}, to Honeywell. Inquiries concerning licenses for its commercial development should be addressed to:

*Satellite Systems Operation
Honeywell, Inc.
19019 N. 59th Avenue
Glendale, AZ 85308
Phone: (602) 313-5000*

Refer to MSC-23465-1/6-1, volume and number of this NASA Tech Briefs issue, and the page number.

GPS/MEMS IMU/Microprocessor Board for Navigation

Lyndon B. Johnson Space Center, Houston, Texas

A miniaturized instrumentation package comprising a (1) Global Positioning System (GPS) receiver, (2) an inertial measurement unit (IMU) consisting largely of surface-micromachined sensors of the microelectromechanical systems (MEMS) type, and (3) a microprocessor, all residing on a single circuit board, is part of the navigation system of a compact robotic spacecraft intended to be released from a larger spacecraft [e.g., the International Space Station (ISS)] for exterior visual inspection of the larger spacecraft. Variants of the package may also be useful in terrestrial collision-detection and -avoidance applications.

The navigation solution obtained by integrating the IMU outputs is fed back to a correlator in the GPS receiver to aid in tracking GPS signals. The raw GPS and IMU data are blended in a Kalman filter to obtain an optimal navigation solution, which can be supplemented by range and velocity data obtained by use of (1) a stereoscopic pair of electronic cameras aboard the robotic spacecraft and/or (2) a laser dynamic range imager aboard the ISS. The novelty of the package lies mostly in those aspects of the design of the MEMS IMU that pertain to controlling mechanical resonances and stabilizing scale factors and biases.

This work was done by Ching-Fang Lin of American GNC Corp. for Johnson Space Center. Further information is contained in a TSP (see page 1).

In accordance with Public Law 96-517, the contractor has elected to retain title to this invention. Inquiries concerning rights for its commercial use should be addressed to:

*American GNC Corporation
888 Easy Street
Simi Valley CA 93065
Phone No.: (866) 856-8686,
Fax No.: (805) 582-0098*

*E-mail: marketing@americangnc.com
Refer to MSC-23098-1, volume and number of this NASA Tech Briefs issue, and the page number.*