

mate reference sets of weight coefficients for weighted sums of the SAMP features that correspond to known words and/or phrases.

Once training has been done, a SAMP that includes an unknown word is sampled and processed by the SPT, the SPT outputs are used to construct a matrix, the matrix is decomposed into cells, and

neural-network analysis is performed, all in the same manner as that of training. The weight coefficients computed during training are used to determine whether there is a sufficiently close match between an unknown word in the SAMP and a known word in the training database. If such a match is found, the word is deemed to be recognized.

This work was done by C. C. Jorgensen and D. D. Lee of Ames Research Center. Further information is contained in a TSP (see page 1).

This invention is owned by NASA and a patent application has been filed. Inquiries concerning rights for the commercial use of this invention should be addressed to the Ames Technology Partnerships Division at (650) 604-2954. Refer to ARC-15040-1.

➤ Physical Principle for Generation of Randomness

NASA's Jet Propulsion Laboratory, Pasadena, California

A physical principle (more precisely, a principle that incorporates mathematical models used in physics) has been conceived as the basis of a method of generating randomness in Monte Carlo simulations. The principle eliminates the need for conventional random-number generators.

The Monte Carlo simulation method is among the most powerful computational methods for solving high-dimensional problems in physics, chemistry, economics, and information processing. The Monte Carlo simulation method is especially effective for solv-

ing problems in which computational complexity increases exponentially with dimensionality. The main advantage of the Monte Carlo simulation method over other methods is that the demand on computational resources becomes independent of dimensionality. As augmented by the present principle, the Monte Carlo simulation method becomes an even more powerful computational method that is especially useful for solving problems associated with dynamics of fluids, planning, scheduling, and combinatorial optimization.

The present principle is based on coupling of dynamical equations with the corresponding Liouville equation. The randomness is generated by non-Lipschitz instability of dynamics triggered and controlled by feedback from the Liouville equation. (In non-Lipschitz dynamics, the derivatives of solutions of the dynamical equations are not required to be bounded.)

This work was done by Michail Zak of Caltech for NASA's Jet Propulsion Laboratory. For further information, contact iaoffice@jpl.nasa.gov. NPO-43822

➤ DSN Beowulf Cluster-Based VLBI Correlator

Software architecture is scalable to meet faster processing needs for future data processing.

NASA's Jet Propulsion Laboratory, Pasadena, California

The NASA Deep Space Network (DSN) requires a broadband VLBI (very long baseline interferometry) correlator to process data routinely taken as part of the VLBI source Catalogue Maintenance and Enhancement task (CAT M&E) and the Time and Earth Motion Precision Observations task (TEMPO). The data provided by these measurements are a crucial ingredient in the formation of precision deep-space navigation models. In addition, a VLBI correlator is needed to provide support for other VLBI related activities for both internal and external customers.

The JPL VLBI Correlator (JVC) was designed, developed, and delivered to the DSN as a successor to the legacy Block II Correlator. The JVC is a full-capability VLBI correlator that uses software processes running on multiple computers to cross-correlate two-antenna broadband noise data. Components of this new system (see Figure 1)

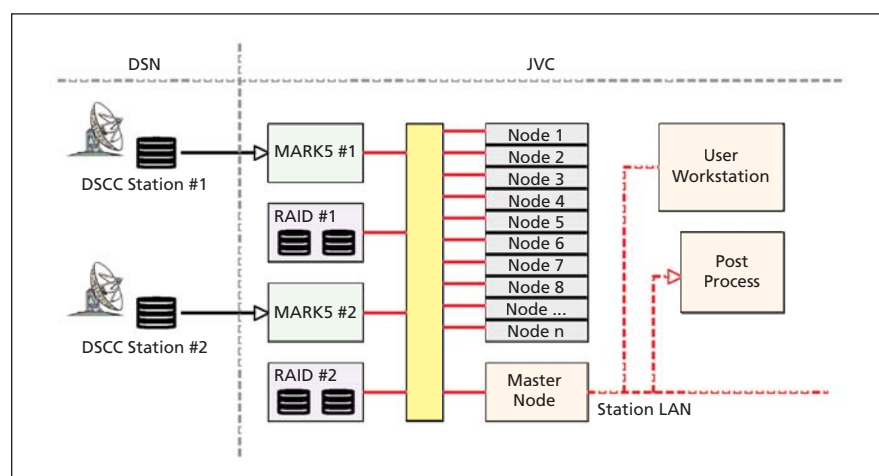

Figure 1. Components of the New Correlator are shown in this simplified block diagram.

consist of Linux PCs integrated into a Beowulf Cluster, an existing Mark5 data storage system, a RAID array, an existing software correlator package (SoftC) originally developed for Delta DOR

Navigation processing, and various custom-developed software processes and scripts.

Parallel processing on the JVC is achieved by assigning slave nodes of the