

ARES I-X FLIGHT TEST—THE FUTURE BEGINS HERE

Stephan R. Davis¹

National Aeronautics and Space Administration, U.S.A.

Abstract

In less than one year, the National Aeronautics and Space Administration (NASA) will launch the Ares I-X mission. This will be the first flight of the Ares I crew launch vehicle, which, together with the Ares V cargo launch vehicle, will send humans to the Moon and beyond. Personnel from the Ares I-X Mission Management Office (MMO) are finalizing designs and fabricating vehicle hardware for a 2009 launch.

Ares I-X will be a suborbital development flight test that will gather critical data about the flight dynamics of the integrated launch vehicle stack; understand how to control its roll during flight; better characterize the severe stage separation environments that the upper stage engine will experience during future flights; and demonstrate the first stage recovery system. NASA also will modify the launch infrastructure and ground and mission operations.

The Ares I-X Flight Test Vehicle (FTV) will incorporate flight and mockup hardware similar in mass and weight to the operational vehicle. It will be powered by a four-segment Solid Rocket Booster (SRB), which is currently in Shuttle inventory, and will include a fifth spacer segment and new forward structures to make the booster approximately the same size and weight as the five-segment SRB.

The Ares I-X flight profile will closely approximate the flight conditions that the Ares I will experience through Mach 4.5, up to approximately 130,000 feet (39,600 meters (m)) and through maximum dynamic pressure ("Max Q") of approximately 800 pounds per square foot (38.3 kilopascals (kPa)). Data from the Ares I-X flight will support the Ares I Critical Design Review (CDR), scheduled for 2010.

Work continues on Ares I-X design and hardware fabrication. All of the individual elements are undergoing CDRs, followed by a two-part integrated vehicle CDR in March and July 2008. The various hardware elements are on schedule to begin deliveries to Kennedy Space Center (KSC) in early September 2008.

Ares I-X is the first step in the long journey to the Moon and farther destinations. This suborbital test will be NASA's first flight of a new human-rated launch vehicle in more than a generation. This promises to be an exciting time for NASA and the nation, as we reach for new goals in space exploration.

¹ Deputy Mission Manager, Ares I-X Mission Management Office, Bldg. 4203, Rm. 6300, Marshall Space Flight Center, AL 35812, email: Stephan.R.Davis@nasa.gov.

Nomenclature

5SS	=	Fifth Segment Simulator
AIT	=	Assembly, Integration, and Test
ARF	=	Assembly and Refurbishment Facility
ATVC	=	Ascent Thrust Vector Controller
BDM	=	Booster Deceleration Motor
BTM	=	Booster Tumble Motor
CDR	=	Critical Design Review
CG	=	Center of Gravity
CM/LAS	=	Crew Module/Launch Abort System
DAC	=	Design Analysis Cycle
DFI	=	Developmental Flight Instrumentation
ECS	=	Environmental Control System
EELV	=	Evolved Expendable Launch Vehicle
FS	=	First Stage
FSAM	=	First Stage Avionics Module
FTINU	=	Fault Tolerant Inertial Navigation Unit
FTS	=	Flight Termination System
FTV	=	Flight Test Vehicle
GFE	=	Government Furnished Equipment
GN&C	=	Guidance, Navigation, and Control
GO	=	Ground Operations
GRC	=	Glenn Research Center
GS	=	Ground Systems
GSE	=	Ground Support Equipment
HMF	=	Hypergol Maintenance Facility
IS	=	Interstage
K ft.	=	Thousands of Feet
kg	=	Kilogram
K lb.	=	Thousands of Pounds
kPa	=	Kilopascal
KSC	=	Kennedy Space Center
LaRC	=	Langley Research Center
LC	=	Launch Complex
m	=	Meter
MLP	=	Mobile Launch Platform
MMO	=	Mission Management Office
MPSS	=	Main Parachute Support System
MSFC	=	Marshall Space Flight Center
NASA	=	National Aeronautics and Space Administration
nm	=	Nautical Miles
OFI	=	Operational Flight Instrumentation
OML	=	Outer Mold Line
RoCS	=	Roll Control System
RPSF	=	Rotation, Processing, and Surge Facility
secs	=	Seconds
SDA	=	Solid Rocket Booster-Derived Avionics
SIL	=	Systems Integration Laboratory
SRB	=	Solid Rocket Booster
TRR	=	Test Readiness Review
TTR	=	Table Top Review
ULA	=	United Launch Alliance

USS	=	Upper Stage Simulator
VAB	=	Vehicle Assembly Building

Introduction

In less than a year, the National Aeronautics and Space Administration (NASA) will launch the Ares I-X mission. This will be the first flight of the Ares I crew launch vehicle, which, together with the Ares V cargo launch vehicle, will eventually send humans to the Moon and beyond. As the countdown to this first Ares mission continues, personnel from across the Ares I-X Mission Management Office (MMO) are finalizing designs and fabricating vehicle hardware for a 2009 launch.

NASA is committed to executing the U.S. Space Exploration Policy, first announced in 2004, which tasked the agency with completing the International Space Station, retiring the Space Shuttle, and developing new launch vehicles capable of providing human access to low-Earth orbit, the Moon, and other destinations. The Ares Projects, based at Marshall Space Flight Center (MSFC) in Huntsville, Alabama, are responsible for building the Ares I crew launch vehicle and Ares V cargo launch vehicle to fulfill this new, ambitious mission (Figure 1). The first test flight of Ares I is being conducted by the Ares I-X Mission Management Office in 2009.



Figure 1. Ares I (left) and Ares V (right) will provide the launch capabilities for America's space exploration effort.

Like the Apollo program, the Ares launch vehicles will rely upon ground, flight, and orbital testing before sending the Orion crew exploration vehicle into space with astronauts on board. The first flight of Ares I, designated Ares I-X, will closely resemble the Saturn I launch vehicle tests, in that it will be a suborbital development flight test (Figure 2).



Figure 2. Ares I-X (right) follows NASA's tradition of incremental development through flight testing, which has included the Mercury, Gemini, and Saturn programs (left).

Mission Overview

The Ares I-X Flight Test Vehicle (FTV) will incorporate a mix of flight and mockup hardware (Figure 3), reflecting a mass and weight similar to the operational Ares I. It will be powered by a four-segment solid rocket motor currently in the Space Shuttle inventory, and will be modified to include a fifth spacer segment that makes the booster approximately the same size and weight as the five-segment SRB. The vehicle also features a new recovery system, including new main parachutes. The new main chutes are 150 feet (47.7 m) across, compared to 136 feet (41.4 m) across for the Shuttle. Ares I-X will be the first flight test of new main parachutes for Ares I.

The Ares I-X flight profile will closely approximate the flight conditions that Ares I will experience through Mach 4.5, at an altitude of about 130,000 feet (39,600 m) and through a maximum dynamic pressure ("Max Q") of approximately 800 pounds per square foot (38.3 kPa) (Figure 4). By basing refinements of the Ares I vehicle design on Ares I-X information, NASA moves one step closer to full-up "test as you fly" scenarios. Each future flight will be staged to affect future milestone reviews. Ares I-X supports the Ares I Critical Design Review (CDR), scheduled for 2010.

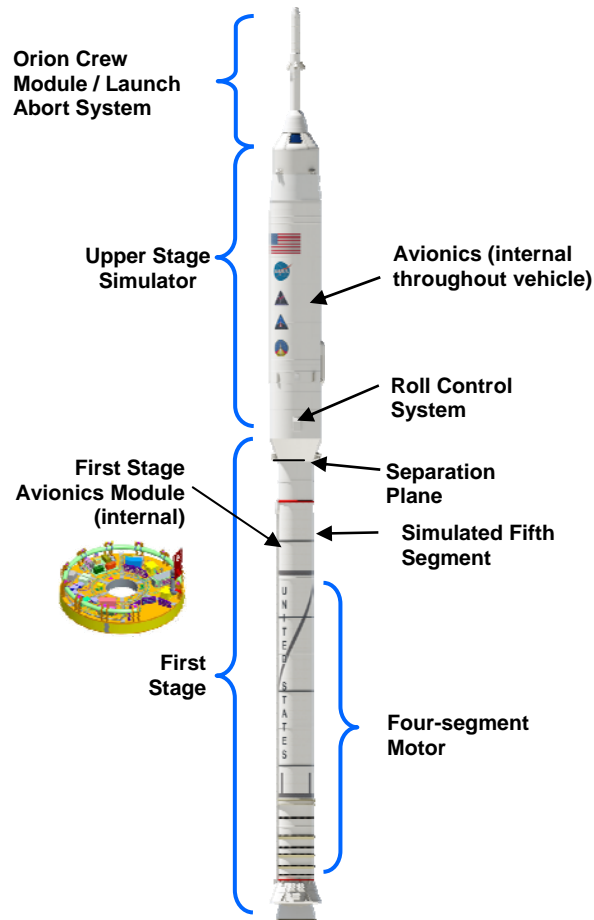

Figure 3. The Ares I-X provides an early opportunity to test the flight configuration of the Ares I crew launch vehicle.

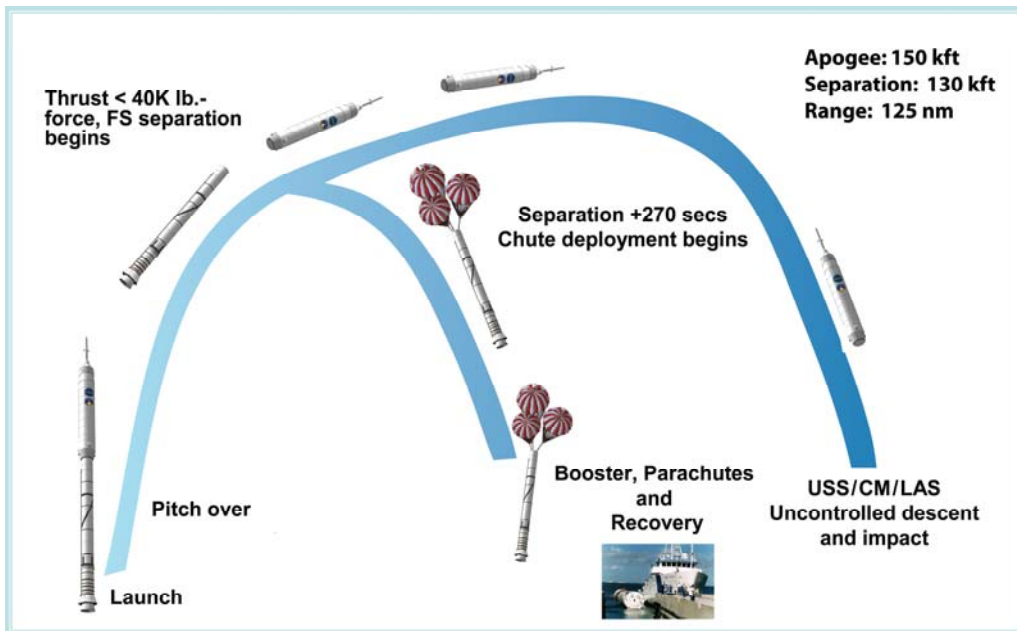

Figure 4. The Ares I-X flight profile closely resembles the uncrewed Saturn I flights of the 1960s.

The Ares I-X mission will be NASA's first flight test of a new human exploration vehicle since 1981. As such, it returns the agency to its history as a pioneering organization, taking on technical risks to develop new space hardware. The five primary test objectives for the Ares I-X flight test include:

- Demonstrating the ascent flight control system performance with dynamically similar hardware.
- Demonstrating separation between the first and upper stage.
- Characterizing and mitigating the roll torque due to first stage (FS) motor performance and aerodynamic forces.
- Testing the first stage parachute recovery system and separation/entry dynamics.
- Validating assembly and processing flow, as well as launch and recovery operations.

These objectives are all attainable using a combination of existing flight hardware and simulator hardware equipped with environmental, acceleration, and other sensors.

Ares I-X provides the first opportunity to test new assembly, integration, and test (AIT) functions at Kennedy Space Center (KSC). When vehicle elements begin arriving at KSC by October 2008, they will be moved to the Assembly and Refurbishment Facility (ARF), where developmental flight instrumentation (DFI) will be integrated and the upper stage simulator (USS) segments will be stacked in smaller "super stacks" to support final assembly of the vehicle in the Vehicle Assembly Building (VAB).

The vehicle will be launched from KSC Launch Complex (LC) 39B, which will be used as a backup launch-on-demand facility for the Shuttle during the servicing mission (STS-125) in October 2008. Once STS-125 is completed, LC 39B will be transferred to the Ares Projects for use on the flight test. Because of its Shuttle-ready state, LC 39B will need to be modified slightly to support Ares I-X until a full tear-down and redesign of the complex can be begun in 2010. Additional vehicle interfaces and a sway damper will be added to the Mobile Launch Platform (MLP) to accommodate the much taller Ares I-X vehicle, which is 325 feet (99 m) tall, as opposed to the Shuttle, which stands 184 feet (56 m) tall. In addition, the Ares I-X upper stage simulator (USS) will include a series of interior ladders and ring-shaped platforms to allow

Ground Operations personnel to access the inside of the vehicle prior to launch. The ground support systems also include an environmental control system (ECS) to keep the avionics and ground staff cool prior to liftoff. The ECS will have a T-0 disconnect connection between the ground systems and the Flight Test Vehicle (FTV), which remains intact until the first stage ignition command (T-0) is issued.

Work continues on Ares I-X design and hardware fabrication. All of the individual elements are undergoing or have completed CDRs, which were followed by a two-part integrated vehicle CDR in March and July 2008.

Progress on Mission Hardware and Facilities

The Ares I-X mission was authorized to proceed in spring 2006. Given its rapid development cycle, hardware design and manufacturing have occurred nearly simultaneously to meet the launch date. Thus, while the CDR began in March 2008, much of the flight hardware was already well through the fabrication process. The CDR was completed successfully July 24. The various hardware elements are on schedule to begin deliveries to KSC by October 2008.

First Stage

As noted earlier, the first stage (Figure 5) is using a four-segment solid rocket motor from the Shuttle inventory. New forward structures are being manufactured by a contractor partner. These new structures will be heavier than the Ares I hardware and will be made mostly of steel. The frustum and aeroshell on the operational Ares I will not be reused and will be made of carbon composites. The Ares I forward skirt and forward skirt extension will be made of aluminum.

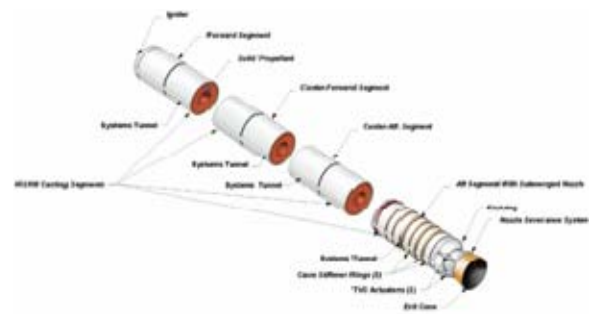

Figure 5. Reusable Solid Rocket Motor details.

Frustum—The frustum connects the first stage to the upper stage. Machining on the frustum was completed in June 2008.

Forward Skirt Extension—The forward skirt extension, which houses the Main Parachute Support System (MPSS), is scheduled to be delivered to the ARF in late July 2008. The Ares I-X separation plane will be between the frustum and the forward skirt extension (Figure 6). A field test of the separation system was conducted at ATK's Promontory site in July 2008. Work also began on installing MPSS hardware in July.

Forward Skirt—The forward skirt, which helps Ares I-X match the outer mold line of Ares I, is due to be delivered to the ARF in late July 2008.

5th Segment Simulator (5SS)—The structure of the fifth segment simulator (also called 5SS or the XL segment) is 10 percent complete. The 5SS (Figure 7) houses the First Stage Avionics Module (FSAM), the Flight Termination System (FTS), and other components. The first of the 5SS components arrives at the ARF in July 2008, with additional sections delivered in August 2008.



Figure 6. The test of the forward skirt extension's separation system verified the effectiveness of the linear shaped charge and its shock effects.

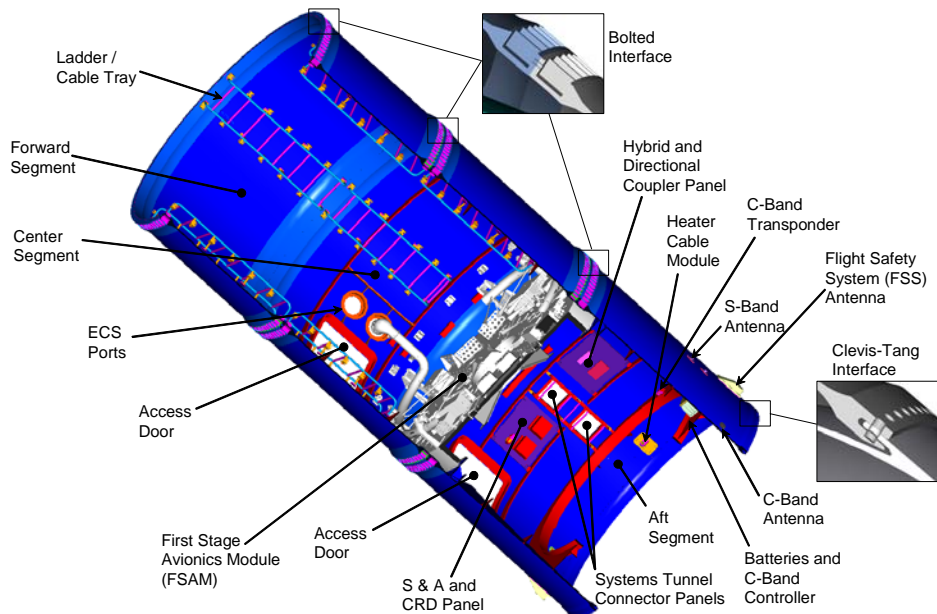

Figure 7. This computer-generated interior view of the 5th Segment Simulator shows avionics components and access interfaces.

Motor Segments—The motor segments are currently in the ARF, undergoing installation of DFI and thermal protection systems (TPS). They are scheduled to be transferred from the ARF to the Rotation, Processing, and Surge Facility (RPSF) at KSC in October 2008.

Aft Skirt—The aft skirt (Figure 8), like the motor segments, uses existing Space Shuttle hardware. The Ground Systems team at KSC is removing the TPS in the ARF so that additional ballast, booster deceleration motors (BDMs), and booster tumble motors (BTMs) can be

installed. The aft skirt for Ares I-X, when operational, will include eight BDMs and four BTMs. A recent “lean event” at KSC helped increase the schedule margin for the skirt, resulting in a delivery to the RPSF by as much as one month earlier than originally scheduled. The aft skirt is currently scheduled to be delivered to the RPSF in October 2008.

Ares I-X will be the first qualification flight test of the new 150-foot-diameter main parachutes.

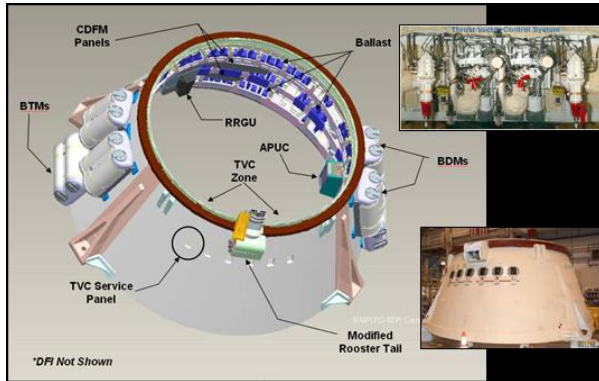

Figure 8. The aft skirt, while Shuttle-legacy hardware, will have hardware added to meet the requirements of Ares I-X.

Separation and Deceleration—Five successful drop tests of the parachute system (Figure 9) have been completed so far. Two additional tests are planned before April 2009.



Figure 9. The main parachutes are in the process of fabrication and drop testing.

Avionics

Ares I-X will carry four types of avionics hardware:

- Guidance, navigation, and control (GN&C) avionics from the Atlas V Evolved Expendable Launch Vehicle (EELV)
- Solid Rocket Booster-derived avionics (SDA) for controlling most of the first stage functions
- A new component, the ascent thrust vector controller (ATVC), which translates

commands between the Atlas V components and the solid-propellant first stage

- Developmental Flight Instrumentation (DFI) and Operational Flight Instrumentation (OFI)

For Ares I, the majority of the first stage avionics will be housed in the instrument unit and forward skirt. For Ares I-X, most of the avionics will be located on the First Stage Avionics Module (FSAM). Like the other pieces of Ares I-X hardware, the avionics components are making great progress toward the 2009

launch date. Table 1 below lists the activities and delivery dates for the avionics.

Table 1. Anticipated delivery dates for Ares I-X avionics

Component(s)	Current Status (As Appropriate)	Anticipated Completion/Delivery
ATVC	CDR completed June 2007 Fabrication under way	October 2008
FSAM	CDR completed April 2008	October 2008
Flight Software	CDR completed March 2008 Test Readiness Review completed April 2008	March 2009
Ground Software (Ground Control, Command, and Communications/GC3)	Formal testing under way	Delivery to KSC October 2008 Installation in MLP by May 2009
Systems Integration Laboratory Vehicle Flight Control Testing Flight Simulation Testing	Ongoing Ongoing	October 2008 May 2009
OFI / DFI Sensors and Harnesses	Sensors acquired or on order Undergoing Table Top Reviews as completed	<i>Cable Harnesses</i> CM/LAS October 2008 USS October 2008 FS October 2008 <i>OFI Harnesses</i> FS/USS October 2008
Fault Tolerant Inertial Navigation Unit (FTINU)	Qualification testing complete Delivered to United Launch Alliance in March 2008	Delivery to KSC March 2009
SDA	Fabrication begun December 2007	August 2008

Upper Stage Simulator

The USS (Figure 10) is made up of cylindrical segments that will be stacked and integrated at KSC for launch. The USS segments are being fabricated by NASA personnel at Glenn Research Center (GRC) in Ohio. As noted earlier, GRC is completing the assembly of these segments, along with their internal structures (Figure 11).

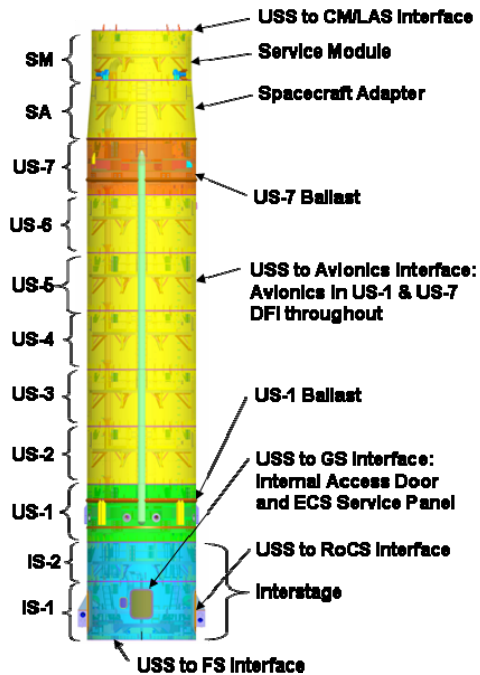

Figure 10. This engineering diagram depicts the order and sizes of the USS segments.



Figure 11. This image shows the interior of the USS

The USS is a mass simulator. It provides the majority of adjustable ballast for the vehicle's mass, center of gravity (CG), and moment of inertia distribution. The 2-inch- (5-centimeter) thick ballast plates are approximately 7,000 pounds (lbs.) (3,175 kilograms (kg)) each. The US-1 segment holds 16 plates \pm 2 plates, equaling approximately 112,000 lbs. (50,802 kg). The US-7 segment holds 5 plates \pm 2 plates, weighing approximately 35,000 lbs. (15,875 kg). The total adjustable ballast is around 147,000 lbs. (66,678 kg). These ballast plates simulate the mass of the liquid hydrogen and liquid oxygen that would normally be present in the upper stage propellant tanks in Ares I.

The USS is designed with 11 segments: 5 common segments (US-2, 3, 4, 5, 6), 2 adjustable ballast segments (US-1 and 7), and 4 complex segments (Interstage (IS)-1 and IS-2, Spacecraft Adapter (SA), and Service Module (SM)).

Each segment is approximately 9.5 feet (2.9 m) tall to accommodate manufacturing and transportation constraints. Outer Mold Line (OML) protuberances are all bolted on and

assembled on individual segments prior to shipping except the Ullage Motors (4x) and Roll Control System (RoCS) Modules (2x) located on the US-1 segment. These items will be shipped separately. An internal access door on US-1 and platforms and ladders provide access to the entire USS, the FS Frustum, and CM/LAS.

USS has successfully completed three Critical Design Reviews, which were ordered by segment complexity, with the "Charge 1" segments being the least complex and "Charge 3" incorporating the Roll Control System and avionics. Charge 1 hardware has already been fabricated. Charge 2 is due to be completed on schedule. Charge 3 hardware fabrication has been started. Manufacturing processes and procedures have been successfully demonstrated. Most of the USS hardware is due to be shipped to KSC by October 2008.

Roll Control System

The active roll control system (RoCS) provides rotational azimuth control for performing a 90-degree roll maneuver to orient the vehicle's telemetry antennas after liftoff. It also will mitigate against adverse roll torques (self- and aero-induced) during ascent. The number of RoCS pulses will be measured in flight and will help inform the RoCS for the final Ares I design. The Roll Control System is an integral, modular, bi-propellant propulsion system housed in the USS Interstage segment (Figure 12). The RoCS uses off-the-shelf and government-furnished equipment (GFE) components—including nitrogen tetroxide and monomethyl hydrazine propellant tanks, helium pressurization tanks, and engine nozzles. This GFE was harvested from Peacekeeper missiles, then re-integrated into a system for RoCS.

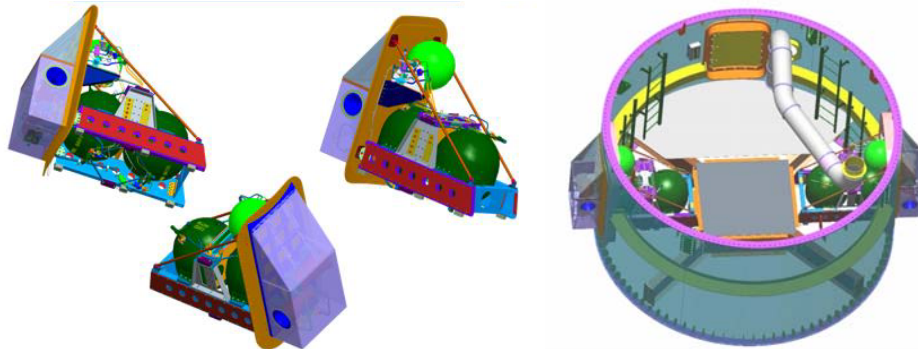

Figure 12. The images at left depict the RoCS module from various orientations to reveal interior and exterior details, including the aerodynamic protuberance. The image at right shows the internal arrangement of the RoCS within the interstage segment.

Duty cycle testing for RoCS was conducted at the White Sands Test Facility in late 2007, and fuel tanking and detanking tests were performed at KSC in early 2008. This verification testing, performed at Hypergol Maintenance Facility (HMF):

- Demonstrated loading pressurant and propellant (using de-ionized water) into Peacekeeper tanks/fill valve configuration
- Used HMF GSE planned for RoCS flight module loading
- Verified and validated procedures and hardware well in advance of actual propellant loading in flight modules.

The RoCS team is focused on completing hardware fabrication and integrating it into the modules, while working verification activities in parallel, leading to a Hardware Acceptance Review early September 2008. The RoCS team has high confidence that it will meet its delivery schedule for the 2009 launch.

Crew Module / Launch Abort System Simulator

Like the USS, the CM/LAS portion of Ares I-X will be simulator hardware (Figure 13). These forward sections differ slightly from the current iteration of the Ares I design because Ares I-X was baselined during an earlier design analysis cycle (DAC). However, the CM/LAS will still provide critical information about aerodynamic and acoustic loads on the Orion crew

exploration vehicle. A total of 362 DFI sensors will be placed on and in the forward structures. The data from these sensors will be transmitted to the ground via telemetry. The sensors might also provide visibility into the thrust oscillation issue Ares I is studying. The CM/LAS CDR was completed in mid-March 2008. Hardware drawings have been completed, and the hardware itself is being fabricated. NASA's Langley Research Center (LaRC) is responsible for CM/LAS design and fabrication, installation and checkout of DFI, plus handling ground support equipment (GSE).

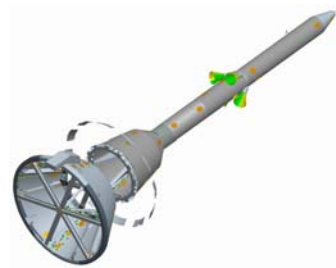

Figure 13. The Ares I-X CM/LAS simulator completed its CDR in February 2008.

The CM/LAS structure consists of several primary components, including the Orion crew module (CM) simulator, the LAS nozzles, the nosecone, and a transition structure between the mast and the CM known colloquially as a “party hat” (Figure 14).

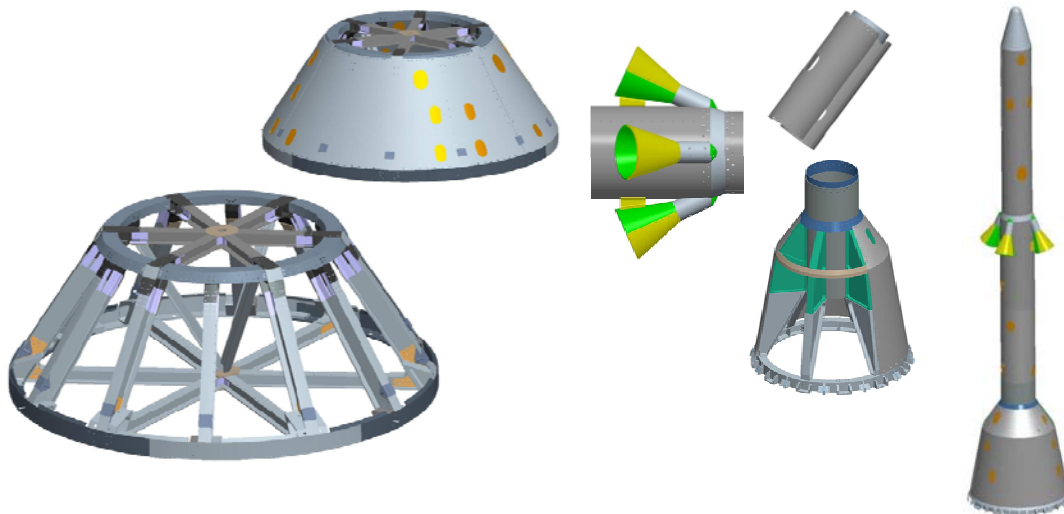

Figure 14. The CM/LAS components will match the shape and mass properties of the operational crew module and launch abort system.

The GO and CM/LAS teams are working together to ensure hardware integration and operations in the Vehicle Assembly Building (VAB) once the CM/LAS arrives at KSC in November 2008. The LAS Tube segment (Figure 15) is currently being fabricated, as are the attachments for the simulated motor nozzles. Upon completion of the tube, assembly of CM/LAS “party hat” will commence.



Figure 15. The LAS tube section is in the midst of fabrication.

Ground Systems / Ground Operations (GS/GO)

The Ares I-X flight will provide valuable experience for the KSC Ground Systems and Ground Operations teams in integrating,

stacking, and launching Ares I. Most of the ground systems to be built for Ares I-X have undergone a 90 percent review and begun fabrication. Among the activities to be addressed are:

- Transporting the vehicle elements to KSC
- Loading RoCS propellants in the Hypergol Maintenance Facility (HMF)
- Processing the vehicle in the ARF and RPSF
- Stacking the vehicle in the VAB
- Conducting vehicle rollout, and launch and recovery operations.

The USS segments and CM/LAS will be assembled into five stacks and the DFI will be tested in VAB High Bay 4. This will include integrating the first stage 5th spacer segment and forward structures into Stack 1. The FS segments and the stacks will be integrated in High Bay 3. The baseline schedule includes ten days for integrated testing. Closeouts—except for the Lower 5SS door (Ordnance Access)—are completed prior to rolling to the pad (Figure 16).



Figure 16. The VAB (left) will modify existing Shuttle handling hardware to stack Ares I-X.

GO is working to update the sequence of events and scheduling of ground asset usage which includes coordination with Shuttle operations. Some of the revised planning is a result of the Shuttle Hubble mission launch date change. The Hubble mission has affected when the MLP-1 will be available for turnover to Ares I-X.

Concluding Remarks

NASA is well on its way toward proving early design, manufacturing, and operational processes for the first flight of Ares I. Data and operational lessons learned from Ares I-X will ensure the safety and reliability of America's newest launch vehicle. From the propulsion systems to the flight simulator hardware, avionics, and ground systems, the Ares I-X team has made great progress in the last two years, and had demonstrated that it is on track to meet its 2009 launch date.

IAC-07-D2.6.04



National Aeronautics and Space Administration

Ares I-X Flight Test— The Future Begins Here

*Stephan R. Davis
Deputy Mission Manager*

2009 International Astronautical Conference

www.nasa.gov





- ◆ **Deliver crew and cargo for missions to International Space Station (ISS) and to Moon and beyond**
- ◆ **Continuing progress toward design, component testing, and early flight testing**
- ◆ **Ares I Crew Launch Vehicle**
 - Will carry 6 crew to ISS, 4 to Moon
 - First flight test 2009
 - Initial Operating Capability 2015
- ◆ **Ares V Cargo Launch Vehicle**
 - Will launch Earth departure stage and Altair lunar lander to low Earth orbit for lunar missions
 - Largest launch vehicle ever designed
 - Will begin detailed development work in 2011



- ◆ **Ares I-X is a development test flight to provide engineering data to inform the design of the Ares I prior to CDR**

Ares I will replace the Space Shuttle which is scheduled for 2010 retirement

- ◆ **Ares I-X is an uncrewed, sub-orbital development flight test**
- ◆ **Ares I-X will provide opportunity to test ground facilities and operations at NASA's Kennedy Space Center**



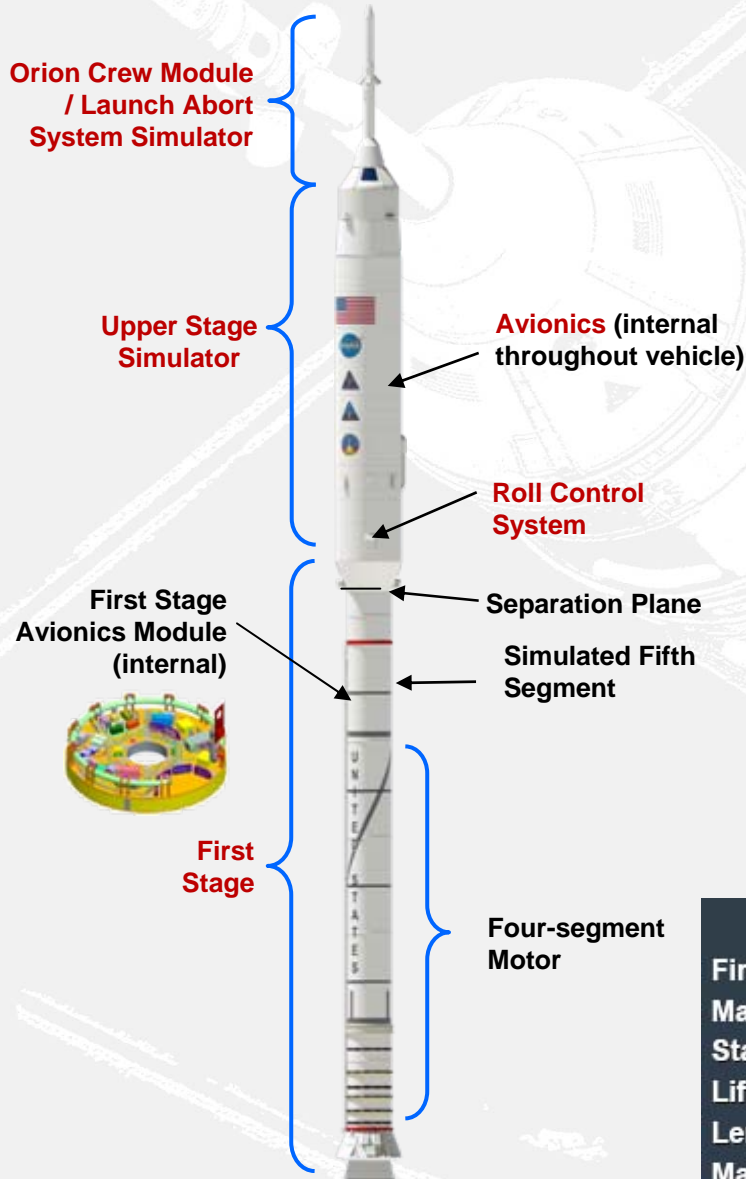

◆ Combines proven space flight and simulated hardware

• Space flight hardware includes:

- Four-segment solid rocket booster (Space Shuttle)
- Atlas V-based avionics
- Roll control system (Peacekeeper)
- Separation system (Space Shuttle)
- Parachutes deceleration system (Space Shuttle)
- Booster deceleration and tumble motors (Space Shuttle)
- Developmental flight instrumentation

• Simulator hardware

- Upper stage
- Orion crew module
- Launch abort system
- Fifth segment of booster

	Ares I-X	Ares I
First Stage Max. Thrust (vacuum):	14.1M N (3.13M lbf)	15.8M N (3.5M lbf)
Max. Speed:	Mach 4.7	Mach 5.84
Staging Altitude:	39,624 m (130,000 ft)	57,453 m (188,493 ft)
Liftoff Weight:	834k kg (1.8M lbm)	927k kg (2.0M lbm)
Length:	99.1 m (327 ft)	99 m (325 ft)
Max. Acceleration:	2.46 g	3.79 g



P(1) Demonstrate control of a dynamically similar, integrated Ares I/Orion, using Ares I relevant ascent control algorithms

P(2) Perform an in-flight separation/staging event between a Ares I-similar First Stage and a representative Upper Stage

P(3) Demonstrate assembly and recovery of a new Ares I-like First Stage element at KSC

P(4) Demonstrate First Stage separation sequencing, and quantify First Stage atmospheric entry dynamics, and parachute performance

P(5) Characterize magnitude of integrated vehicle roll torque throughout First Stage flight

Ares I-X Development Flight Test

P2) Perform in-flight separation/staging event at 124 sec ~ 130,000 feet

~ 150,000 feet

Vehicle Height:	327 feet
Weight at Ignition:	1.8 M-lbm
Max. Acceleration:	2.5 g's
Max. Speed:	Mach 4.7

P4) Demonstrate FS entry dynamics and sequencing of events (parachute deployment, etc.)

P5) Characterize integrated vehicle roll torque

in-flight separation plane

P1) Demonstrate controlability

P3) Demonstrate assembly and recovery of an Ares I similar FS

**USS/CM/LAS
Uncontrolled descent and impact**

Booster, parachutes and recovery



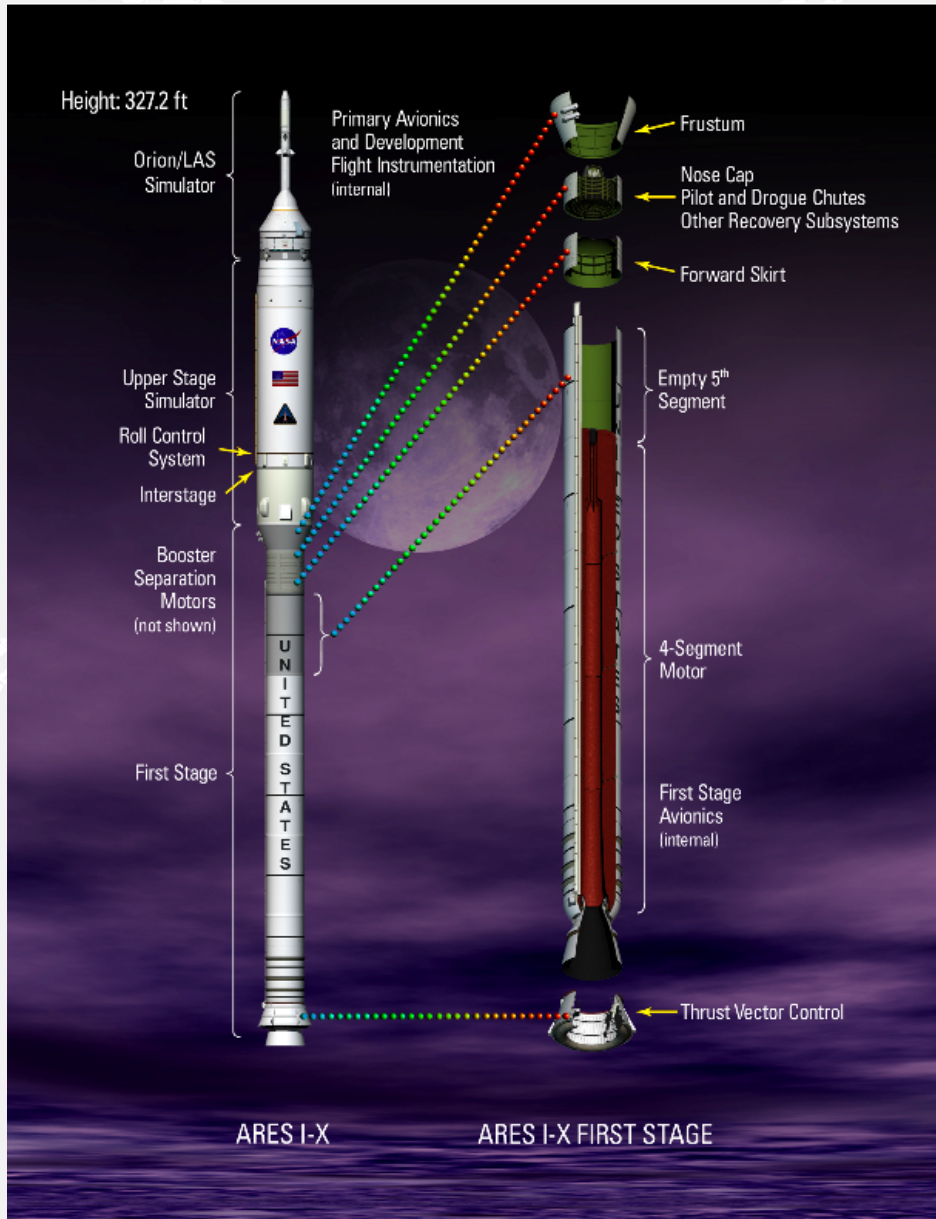

◆ Heritage Hardware

- 4 Segment Reusable Solid Rocket Motor (RSRM) w/Nozzle
- Thrust Vector Control (TVC)
- Flight Termination System (FTS)
- Nose Cap w/Thrusters
- Booster Separation Motors (BSMs)

◆ Modified Heritage Hardware

- Shuttle Derived Avionics
- Aft Skirt

◆ New Developments for Ares I-X

- Fifth Segment Simulator (5SS)
- Forward Skirt (FS)
- Forward Skirt Extension (FSE)
- Main Parachute Support Structure (MPSS)
- Frustum

◆ Ares I Designs

- Parachutes
- FTS Extension to Aft Segment

◆ Managed at the NASA Marshall Space Flight Center, Huntsville, AL



Redundant Rate Gyro (RRGU)

Fault Tolerant Inertial Navigation Unit (FTINU)

Redundant Rate Gyro (RRGU)



First Stage Avionics Module (FSAM) (Lockheed Martin Space Systems (LMSS))

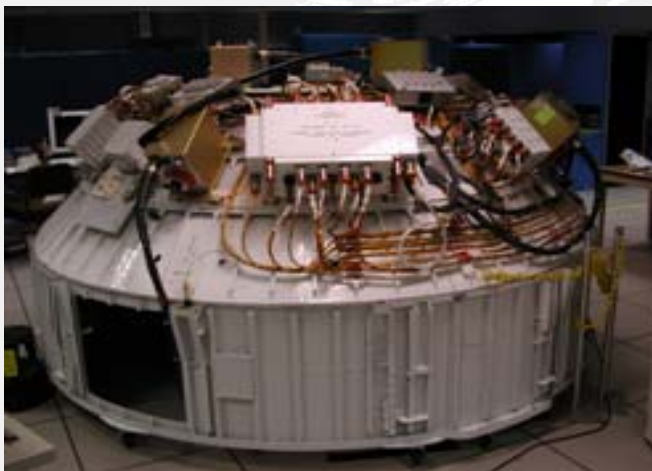

Atlas V System Integration Lab (SIL) (LMSS)

- ◆ **Primary avionics subsystems:**
 - **FSAM (located in First Stage fifth segment)**
 - **Guidance & Control System**
 - **Ground Command, Control, and Communication (GC3)**

- ◆ **Managed at the NASA Marshall Space Flight Center, Huntsville, AL**

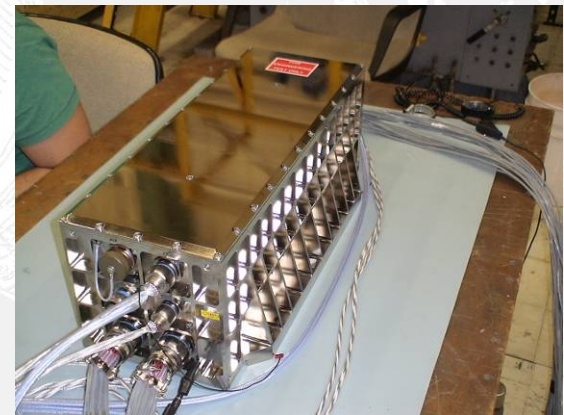

Ascent Thrust Vector Controller (ATVC) (Honeywell International)



Avionics Progress



Component(s)	Current Status (As Appropriate)	Anticipated Completion/Delivery
ATVC	CDR completed June 2007 Fabrication under way	Oct-08
FSAM	CDR completed April 2008	Oct-08
Flight Software	CDR completed March 2008 Test Readiness Review completed April 2008	Mar-09
Ground Software (Ground Control, Command, and Communications/GC3)	Formal testing under way	Delivery to KSC October 2008 Installation in MLP by May 2009
Systems Integration Laboratory Vehicle Flight Control Testing Flight Simulation Testing	Ongoing Ongoing	Oct-08 May-09
OFI / DFI Sensors and Harnesses	Sensors acquired or on order Undergoing Table Top Reviews as completed	<i>Cable Harnesses</i> CM/LAS July 2008 USS October 2008 FS October 2008 <i>OFI Harnesses</i> FS/USS October 2008
Fault Tolerant Inertial Navigation Unit (FTINU)	Qualification testing complete Delivered to United Launch Alliance in March 2008	Delivery to KSC March 2009
SDA	Fabrication begun December 2007	Aug-08

Upper Stage Simulator (USS)

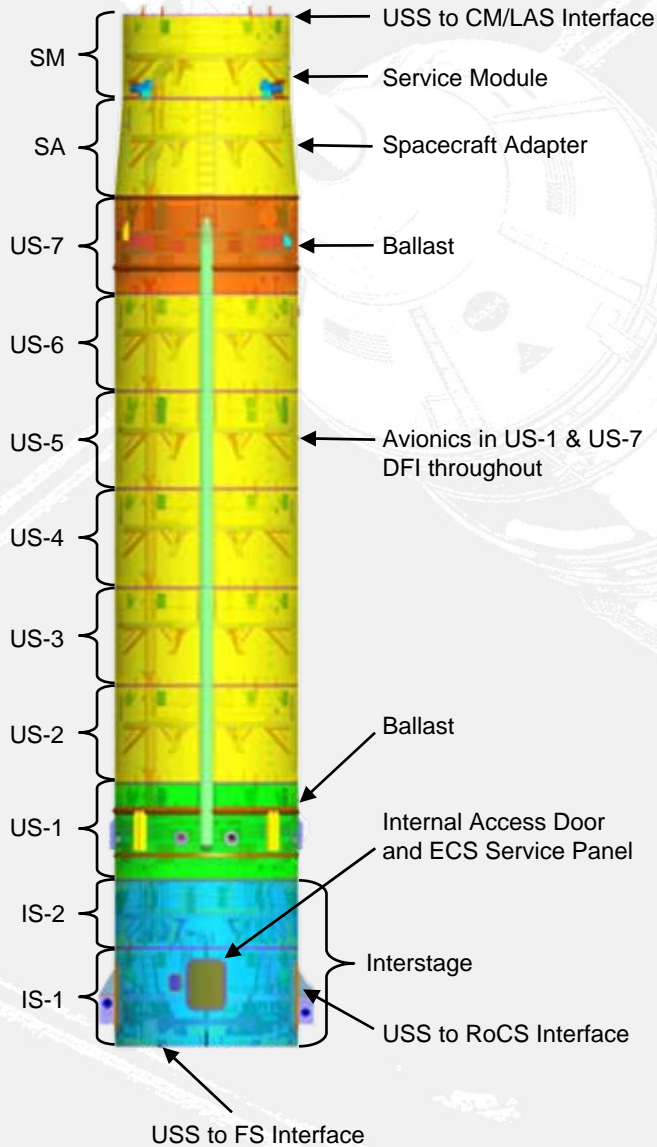

◆ **USS is a mass and Outer Mold Limit (OML) simulator**

◆ **Hardware includes:**

- Interstage (IS) Simulator
- Upper Stage (US) Simulator
- Spacecraft Adapter (SA) Simulator
- Service Module (SM) Simulator

◆ **Developed at the NASA Glenn Research Center, Cleveland, OH**



USS Internal Access Concept

- ◆ Provides access from the Frustum to the CM/LAS
- ◆ Door in the IS-1 segment
 - Internal access platforms and ladders
 - Provides Environmental Control System (ECS) ductwork to maintain a safe work temp, air flow and controlled humidity

Internal access door

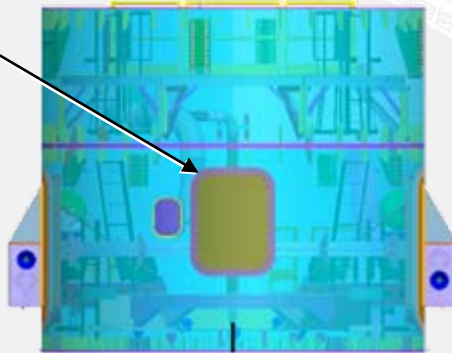

IS-1 Segment

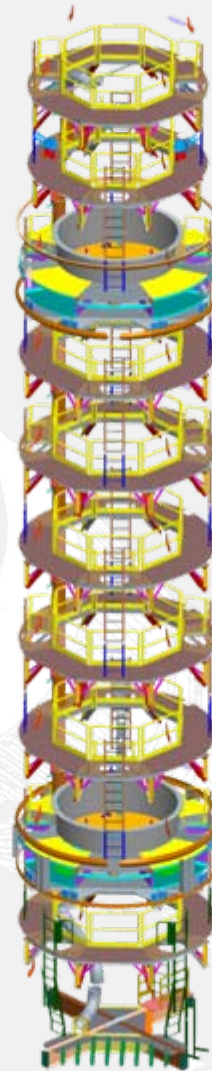

Common access platforms with railings

Ballast platform

FS Frustum

Roll Control System (RoCS)

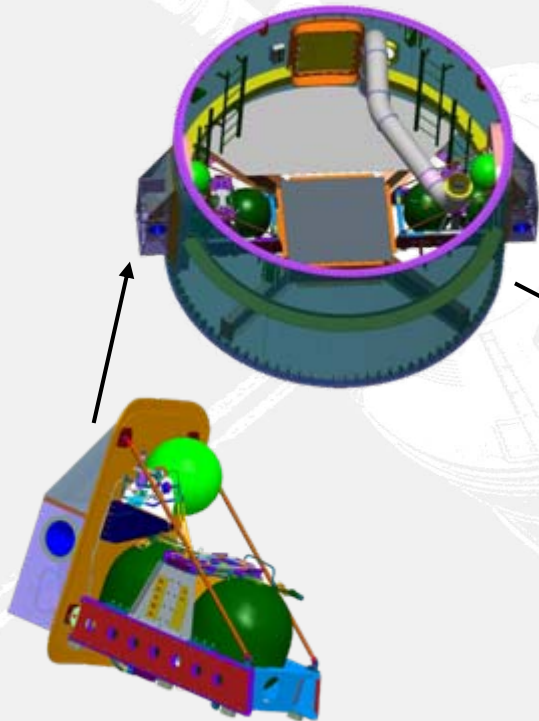

- ◆ Provides post-launch 90-degree roll and mitigation against adverse roll torques
- ◆ Modular propulsion system housed in the Ares I-X USS Interstage
- ◆ Proven space hardware harvested from Peacekeeper 4th Stage
- ◆ Managed at the NASA Marshall Space Flight Center, Huntsville, AL



◆ Instrumented for 924 measurements

- Thermal
- Structures
- GNC/Trajectory
- Aero
- Shock

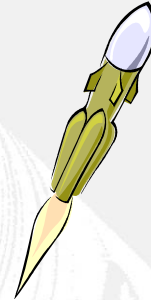

◆ Cameras strategically located

◆ Data to be retrieved via telemetry and a data recorder box that is recovered from the First Stage after flight

◆ Managed at the NASA Langley Research Center, Hampton, VA

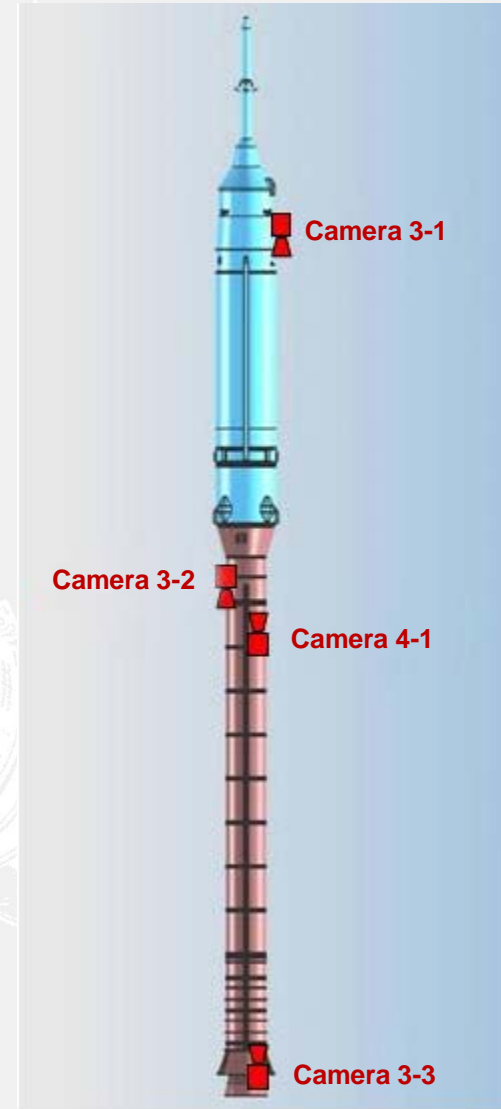

Orion Crew Module/ Launch Abort System (CM/LAS) Simulator

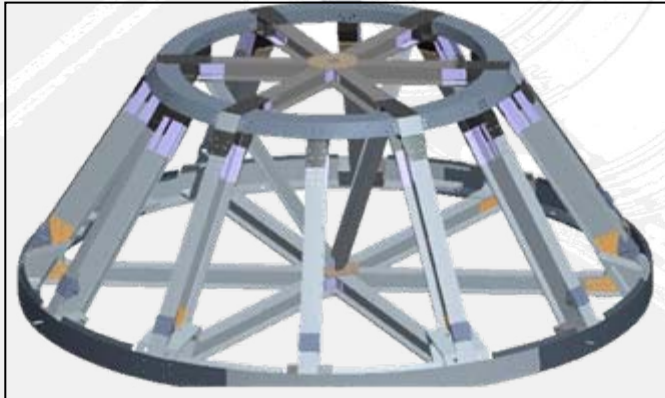
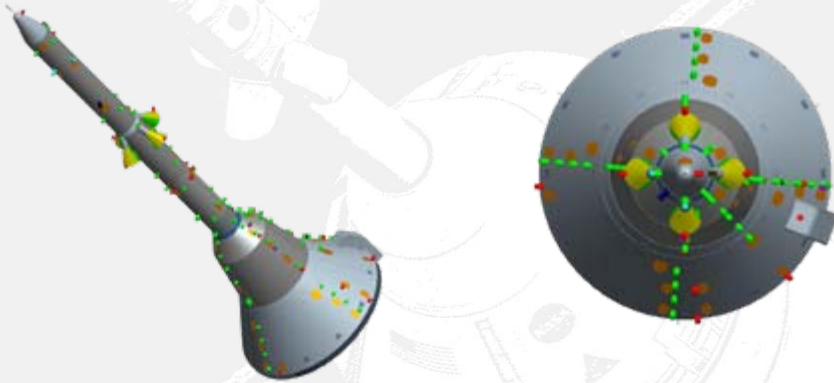

- ◆ **Outer mold limit (OML) resembles earlier Ares I design due to flight test schedule**
- ◆ **Developmental flight instrumentation sensors will measure aerodynamic and acoustic loads**
- ◆ **Developed at the NASA Langley Research Center, Hampton, VA**

Vehicle Assembly Building (VAB) Operations

- ◆ The Upper Stage Simulator (USS) segments and Orion Crew Module/Launch Abort System (CM/LAS) will be assembled into stacks and Development Flight Instrumentation (DFI) tested in VAB Hi-Bay 4
- ◆ The First Stage segments and stacks will be integrated in Hi-Bay 3



Hi-Bay 3 Stacks in VAB

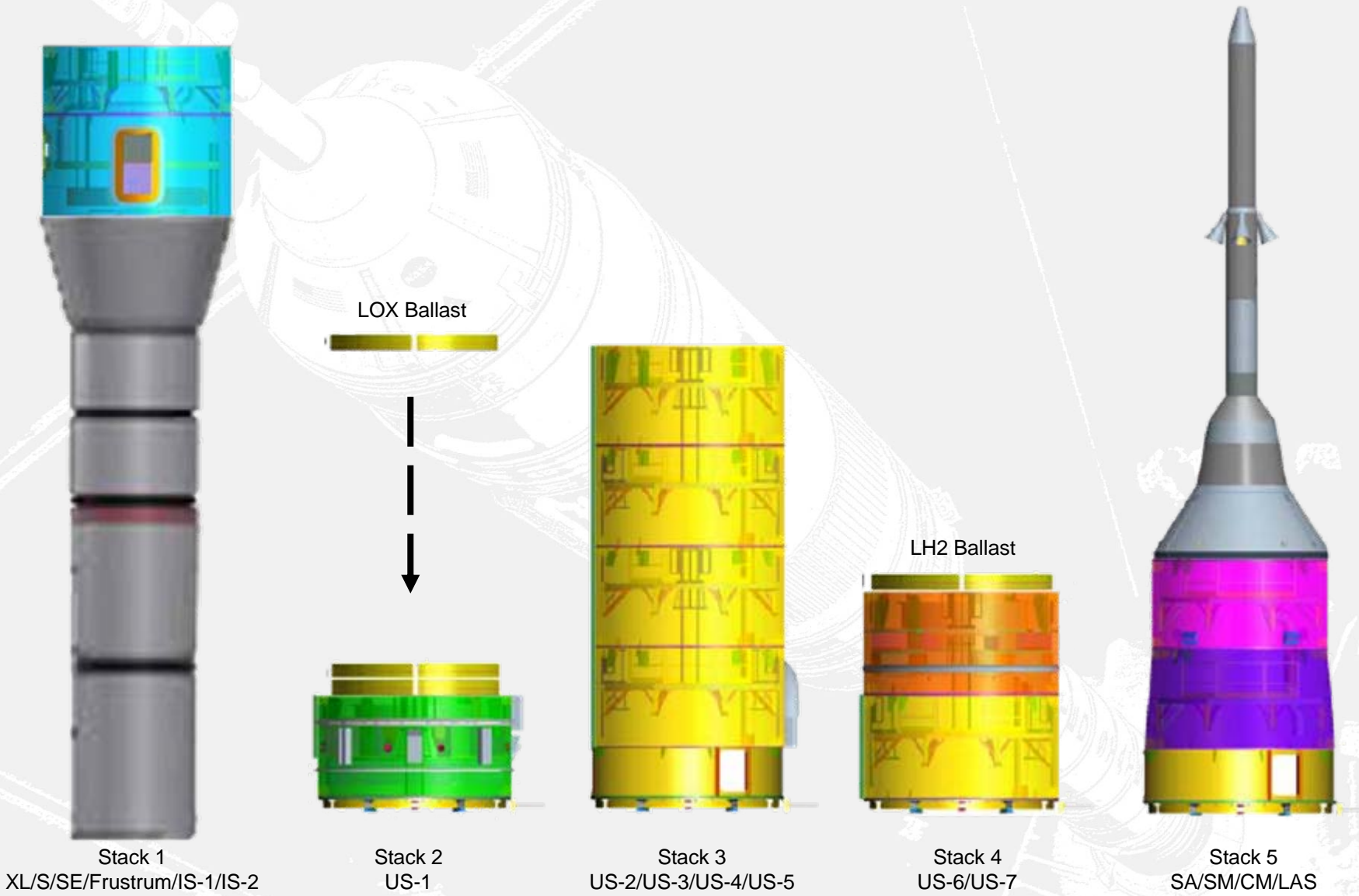

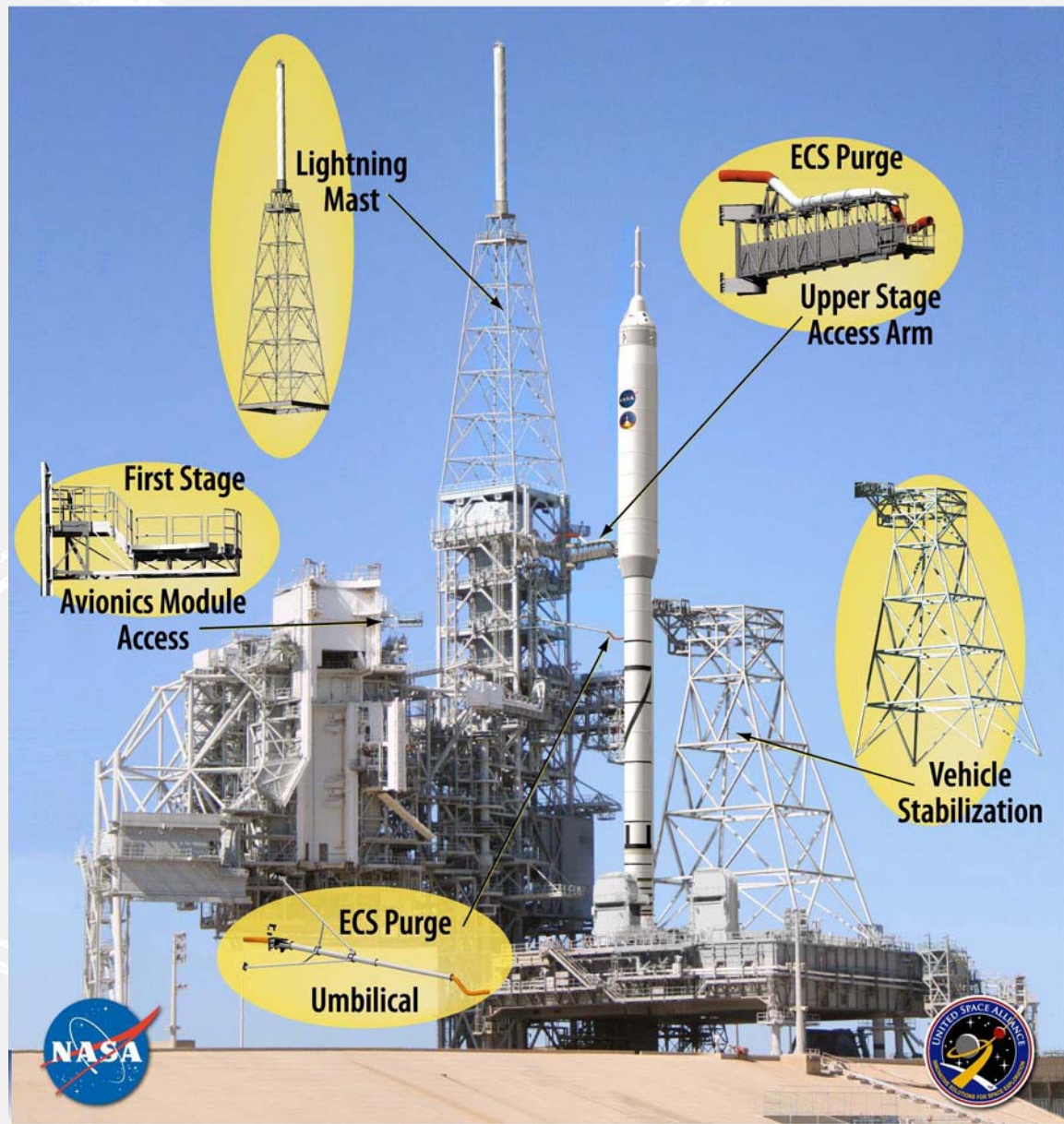

- ◆ Lightning Mast raised 100ft
- ◆ Vehicle stabilization concept shown



- ◆ **Ares I-X is the first flight of NASA's new Constellation Program**
- ◆ **Ares I-X is a developmental test flight to support the Ares I**
- ◆ **Ares I-X is on track for 2009 launch date**
- ◆ **For more information, see <http://www.nasa.gov/ares>**

