

THIS DOCUMENT AND EACH AND EVERY
PAGE HEREIN IS HEREBY RECLASSIFIED
FROM CONF TO UNCLASS
AS PER LETTER DATED 12/12/88
NOTICE # 122

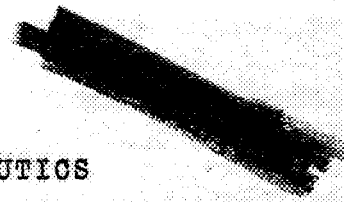

NATIONAL ADVISORY COMMITTEE FOR AERONAUTICS

Special Report #28

THE EFFECT OF LATERAL INCLINATION OF THE THRUST AXIS AND
OF SWEEPBACK OF THE LEADING EDGE OF THE WING
ON PROPULSIVE AND NET EFFICIENCIES OF
A WING-NACELLE-PROPELLER COMBINATION

By Donald H. Wood and Ray Windler
Langley Memorial Aeronautical Laboratory

Special Report - #28

April 1935

NATIONAL ADVISORY COMMITTEE FOR AERONAUTICS

THE EFFECT OF LATERAL INCLINATION OF THE THRUST AXIS AND
OF SWEEPBACK OF THE LEADING EDGE OF THE WING ON
PROPULSIVE AND NET EFFICIENCIES OF
A WING-NACELLE-PROPELLER COMBINATION

By Donald H. Wood and Ray Windler

SUMMARY

This report describes and gives the results of tests made to determine the effect of lateral inclination of the propeller thrust axis to the direction of flight. A wing-nacelle-propeller combination with the nacelle axis located successively parallel to and at 15° to the perpendicular to the leading edge of a wing was tested with the combination at several angles of yaw. Tests of the wing alone at the same angles of yaw were also made. The data are presented in the usual graphical form.

An increase in propulsive efficiency with increase in angle of the thrust axis was found. The change in net efficiency, found by charging the whole nacelle drag to the power unit, was negligible, however, within the range of the tests.

INTRODUCTION

At the request of the Bureau of Aeronautics, tests were made in the N.A.C.A. 20-foot wind tunnel to determine the effect of lateral inclination of the thrust axis of the propeller to the air stream on the propulsive efficiency. The proposal appears to have originated with Mr. W. D. Clark, who had noticed that the nacelles were inclined on some of the Junkers airplanes. Although the most probable reason for this construction seems to be the direction of the slipstream onto the tail surfaces for im-

provement of control, the question was thought to be of sufficient importance to warrant some tests.

Consideration of the problem, in the light of previous knowledge that the influence of the nacelle and propeller is localized in their vicinity, indicated that the tests could be made by mounting the nacelle on a simple wing, yawing the wing to give various angles of the leading edge to the wind direction, and mounting the nacelle at several angles to the airfoil leading edge. A suitable wing and a motor for driving the propeller were available from previous wing-nacelle-propeller tests and the tests were considerably simplified and expedited in consequence.

In addition to measurements necessary in computations of the propulsive efficiencies, tests were made of the wing alone at various angles of yaw and from these measurements the net efficiencies were computed. This report describes the tests and gives the important results obtained.

APPARATUS AND METHODS

The tests were made in the 20-foot propeller-research tunnel which is fully described in N.A.C.A. Technical Report No. 300. N.A.C.A. Technical Report No. 436 describes the 5-foot chord by 15-foot span, 20 percent thick wing and the 4-foot propeller used in the tests. A 25-horsepower, 3-phase alternating current induction motor having a maximum diameter of only 10 inches was used to drive the propeller and also to simulate a nacelle of the type housing a motor shaft. The motor is of smooth contour with the exception of some excrescences in the form of mounting boltheads and is of practically constant diameter except for rounded ends. The only cowling used was a small fairing to run the rear end of the motor into the leading edge of the wing smoothly. Figures 1 and 2 show the wing, motor, and propeller as mounted for testing. It will be noted that the sting was supported by a wire from the roof to allow for the swing of the sting when the wing was yawed.

The tests were run with the wing at -4° angle of attack and with the propeller set 22° at 0.75R. This angle of attack corresponds to a lift coefficient of 0.2 for the wing in normal unyawed position and represents the high-speed flight attitude quite closely. The pitch setting

used is about that required for airplanes of 150 to 160 miles per hour high speed. It is considered that other angles of attack and pitch settings would have shown nearly the same relative results, and the tests were accordingly limited to this one condition. The motor was placed in two positions with respect to the chord line; namely, with shaft parallel to and inclined 15° to the right. With the shaft parallel to the chord the combination was tested with the wing yawed 0° , 5° , and 10° to the left, and with the shaft inclined 15° to the right the combination was tested with the wing yawed 0° , 10° , and 20° to the left. These variations give several combinations of angles of the wing leading edge and propeller shaft to the air flow, as indicated in figures 3 and 4, and cover the range likely to occur in practice. The wing alone was tested at 0° , 5° , 10° , and 20° yaw to determine its drag for the computation of the net thrust and efficiency. The lift was not measured, since it was not practical to do this without complicating the arrangement. Furthermore, at the low angle of attack used the propeller does not affect the lift enough to cause a change in induced drag that would affect the efficiency.

RESULTS

The measured quantities - thrust, drag, motor power, and air speed - are reduced to the usual nondimensional propeller coefficients

$$C_T, \quad \frac{(T - \Delta D) V}{\rho n^2 D^4}, \quad \text{thrust coefficient}$$

$$C_P, \quad \frac{P}{\rho n^3 D^5}, \quad \text{power coefficient}$$

$$\eta, \quad \frac{(T - \Delta D) V}{P} = \frac{C_T V}{C_P n D}, \quad \text{propulsive efficiency}$$

where T , thrust (tension in crankshaft)

ΔD , increase in drag due to the slipstream

V , velocity

ρ , mass density of the air

η , revolution per unit time

D, propeller diameter

P, motor power output

The quantities T and ΔD are not determined separately but rather $T - \Delta D$ is determined as the sum of the net-balance reading with propeller operating and the net-balance reading with propeller removed. In the present tests $T - \Delta D$ represents the desired quantity, the component of thrust in the direction of the velocity, and not the true thrust which, when the thrust axis is inclined, acts at some angle to the direction of velocity.

Figures 5 to 10, inclusive, show the results for the individual tests plotted in the usual manner of coefficients versus $\frac{V}{nD}$. The dispersion of the test points of thrust and power coefficients is an indication of the relative accuracy. The solid curves of C_T and η are the usual thrust-coefficient and propulsive-efficiency curves computed from the drag of the combination without propeller, as discussed above. The dotted curves are net results computed by using the drag of the wing alone at the respective angles of yaw instead of the drag of the combination.

It seems reasonable to consider the engine and propeller together as the propulsive unit, and any drag caused by the engine or its housing should be charged to the efficiency. The net efficiency represents the fraction of the engine power that is available for overcoming the drag of other parts of the airplane, exclusive of propeller losses, and nacelle drag and interference. A comparison of the net efficiencies gives a much better idea of relative merits than does a comparison of propulsive efficiencies.

Table I gives values of the drag which may be of some interest for comparison. The absolute values, of course, serve no useful purpose other than in the computation of the present results.

TABLE I

Thick wing - 5-foot chord, 15-foot span, maximum thickness 20 percent c

Drag at $q = 25.6$ $\alpha = -4^\circ$

Positive angles to right } facing air flow
Negative angles to left }

Angle of wing yaw	Angle of thrust line to air stream	Angle of thrust line to wing chord	Drag, nacelle in place	Increase in drag due to nacelle
Degrees	Degrees	Degrees	Pounds	Pounds
0	0	0	55.5	5.2
-5	-5	0	61.4	6.7
-10	-10	0	66.0	8.6
0	15	15	59.1	8.8
10	5	15	63.4	6.0
20	-5	15	83.7	9.2
			Nacelle removed	
0			50.3	
-5			54.7	
-10			57.4	
-20			74.5	

DISCUSSION

In order to show the effect of yawing the wing when the thrust axis is parallel to the chord, which is analogous to a wing with swept-back leading edge and the thrust axis perpendicular to the leading edge, the results from figures 5 to 7 are replotted in figures 11 to 14. An increase in thrust and power coefficients (figs. 11 and 12) with angle of yaw is to be noted. The propulsive efficiencies likewise increase (fig. 13) the maximum efficiency occurring at higher values of V/nD , indicating higher effective pitch. The net thrust (fig. 14) is increased with the yaw but the higher power (fig. 12) counterbalances the effect and the net efficiency is practically the same,

the maximum difference being 1 percent, which is well within the experimental error.

In the case discussed above the thrust axis is at the same angle to the air stream as the angle of yaw. In the second case (figs. 8 to 10) the nacelle is initially inclined 15° , and as the angle of yaw is opposite to the inclination the thrust-axis direction approaches the air-stream direction, becoming parallel to it at 15° yaw and 5° in the opposite direction at 20° yaw. (See fig. 4.) The data of figures 8 to 10 are replotted in figures 15 to 18 for the different angles of yaw. The agreement of the thrust and power curves for 10° and 20° yaw (figs. 15 and 16), which correspond to equal angles of the thrust axis to air stream, shows quite clearly the predominant effect of the thrust-axis direction. As is to be expected from the position of the nacelle, there is somewhat less blanketing of the wing in the 20° yawed condition than in the 10° and the propulsive efficiency is somewhat higher. Here with the wing leading edge at the largest angle to the air stream the effective pitch of the propeller is increased. The effective pitch change therefore seems to be primarily a function of the direction of the leading edge (fig. 17). The net efficiency (fig. 18) is slightly higher when the thrust axis is nearly parallel to the air stream. The two curves for 10° and 20° yaw corresponding to $\pm 5^\circ$ angle of thrust axis agree within the experimental error. In fact, the net efficiency for the 0° yaw condition (thrust axis inclined 15°), which is only $2\frac{1}{2}$ percent lower, is scarcely outside the limit of accuracy. The effects of direction of leading edge and of the thrust axis are thus shown to be negligible.

Additional evidence of the negligible effect of the direction of the thrust axis is given in the replotted data in figures 19 and 20, with the leading edge of the wing perpendicular to the air stream and the thrust axis at 0° and 15° . The propulsive efficiency is about $7\frac{1}{2}$ percent higher with the thrust axis at 15° but net efficiencies are practically identical (fig. 20). Another comparison is afforded by the plots of figures 21 and 22, with the leading edge swept back 10° and the thrust axis at 5° and -10° to the air stream. Here again there is a higher propulsive efficiency for the greater angle of the thrust axis but the difference in net efficiency is negligible as before (fig. 22).

A comparison may be made in yet another way, as in figures 23 to 26, with the thrust axis at 5° to the air stream and the leading edge swept back 5° , 10° , and 20° . Again the small difference in net efficiencies is to be noted and also the small difference whether the thrust axis is inclined inboard or outboard. Altogether the effects of thrust-axis direction and sweepback of the leading edge seem to be negligible. The Junkers G-38 has the outboard engine thrust axes inclined outward about 4° and the leading edge of the wing swept back about 19° . If this can be taken as an extreme example, the test results discussed here would seem to cover the practical range unless radical increases of angle are proposed.

CONCLUSION

The results of the tests indicate that the effect of the lateral inclination of the thrust-axis direction and of the sweepback of the leading edge of a wing on the net efficiency of a wing-nacelle-propeller combination is negligible in the practical range covered by the tests.

The propulsive efficiency is somewhat greater when the thrust axis is inclined to the direction of flight.

Langley Memorial Aeronautical Laboratory,
National Advisory Committee for Aeronautics,
Langley Field, Va., February 23, 1935.

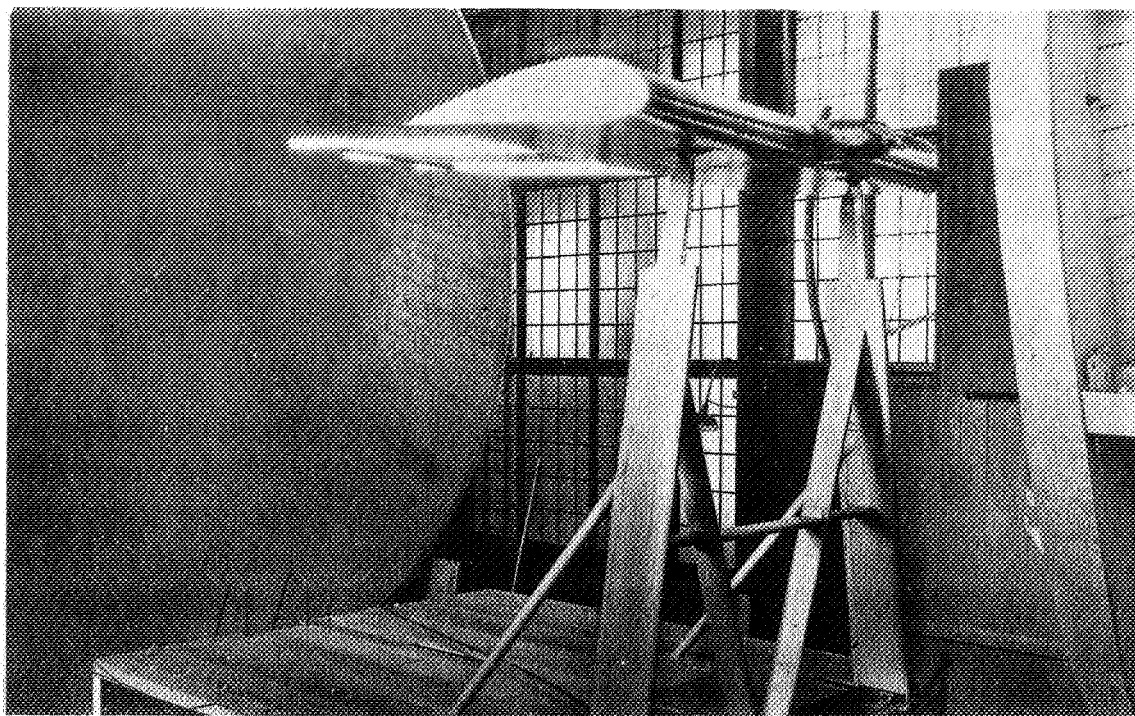

Figure 1.-Nacelle parallel to chord; wing -10° yaw.

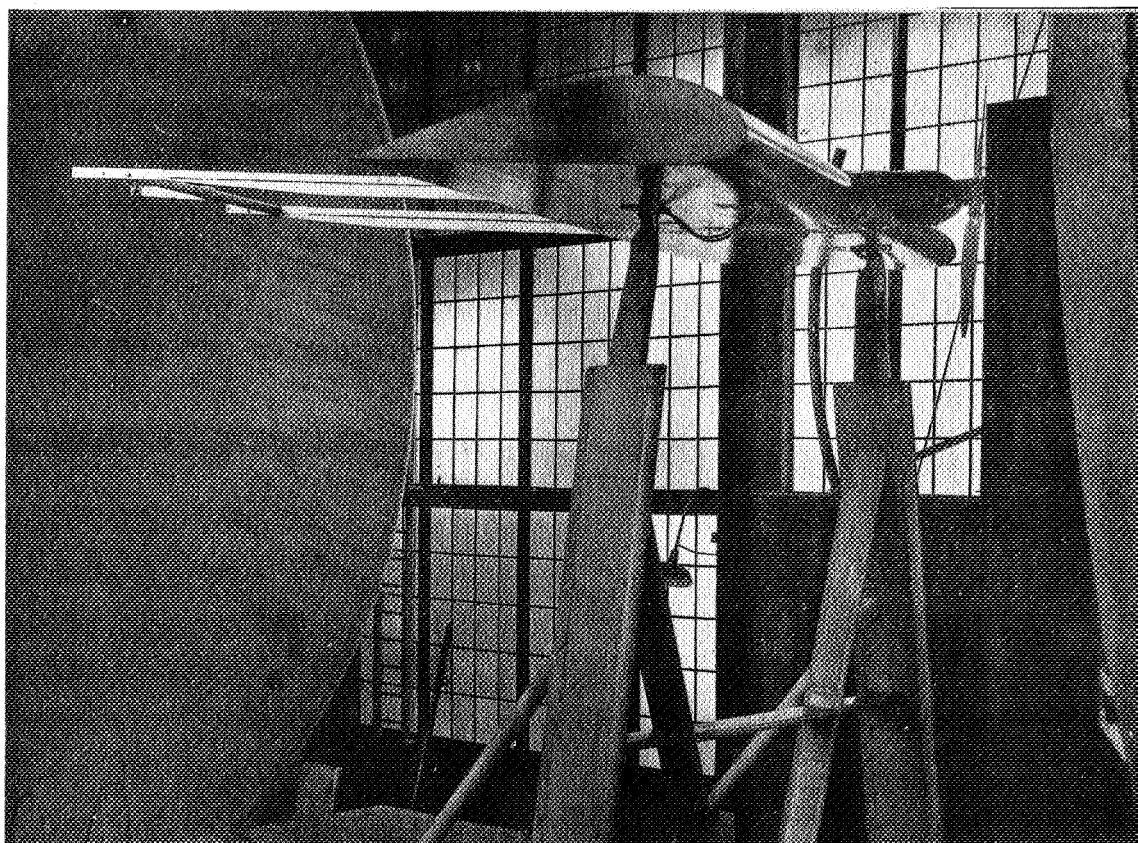
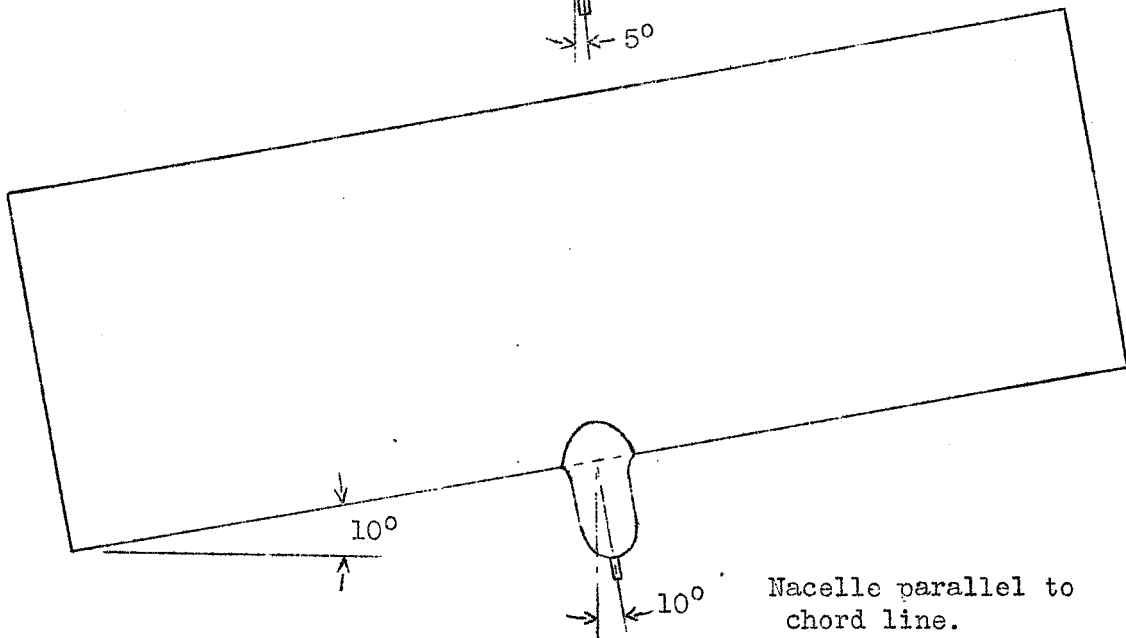
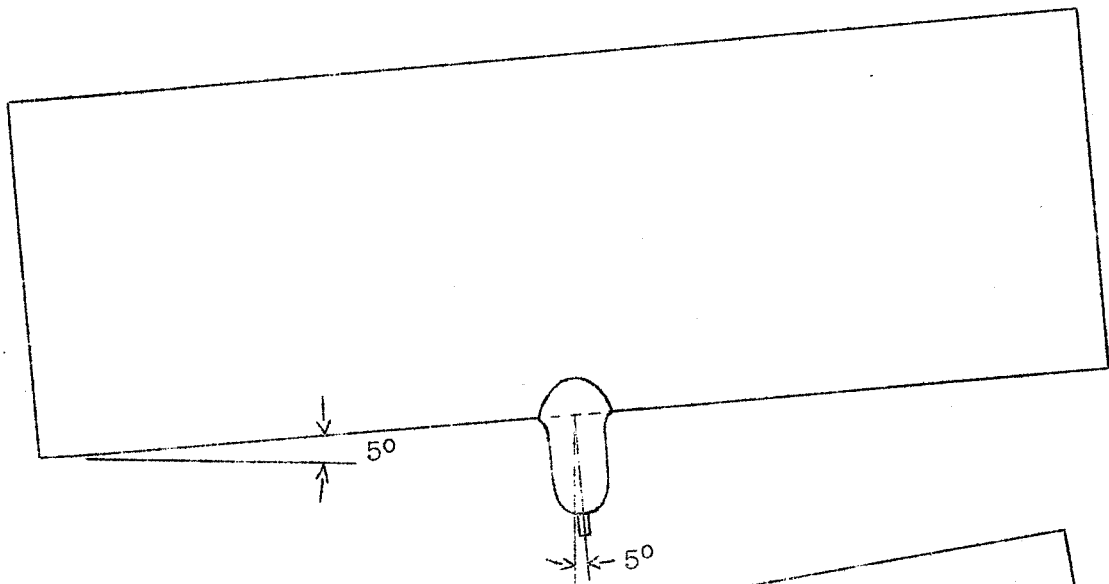
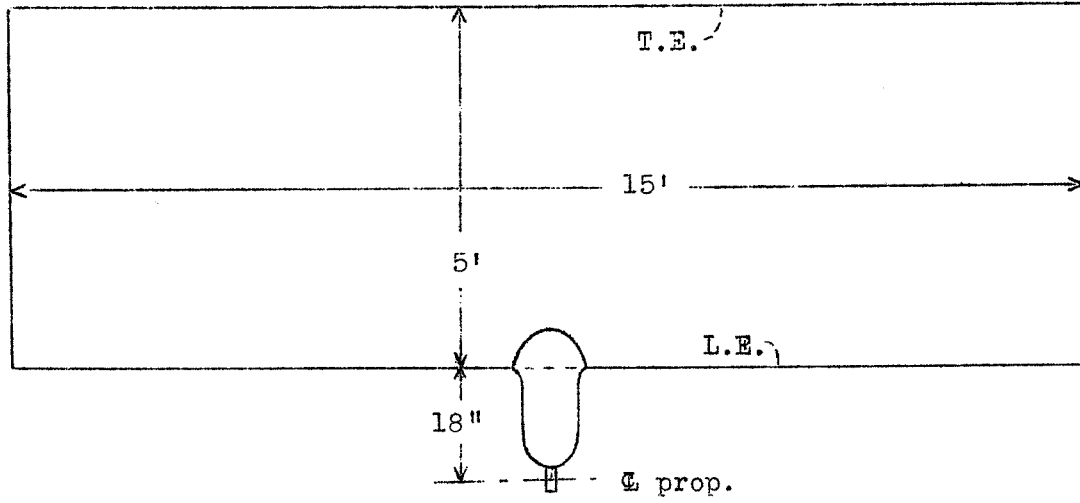
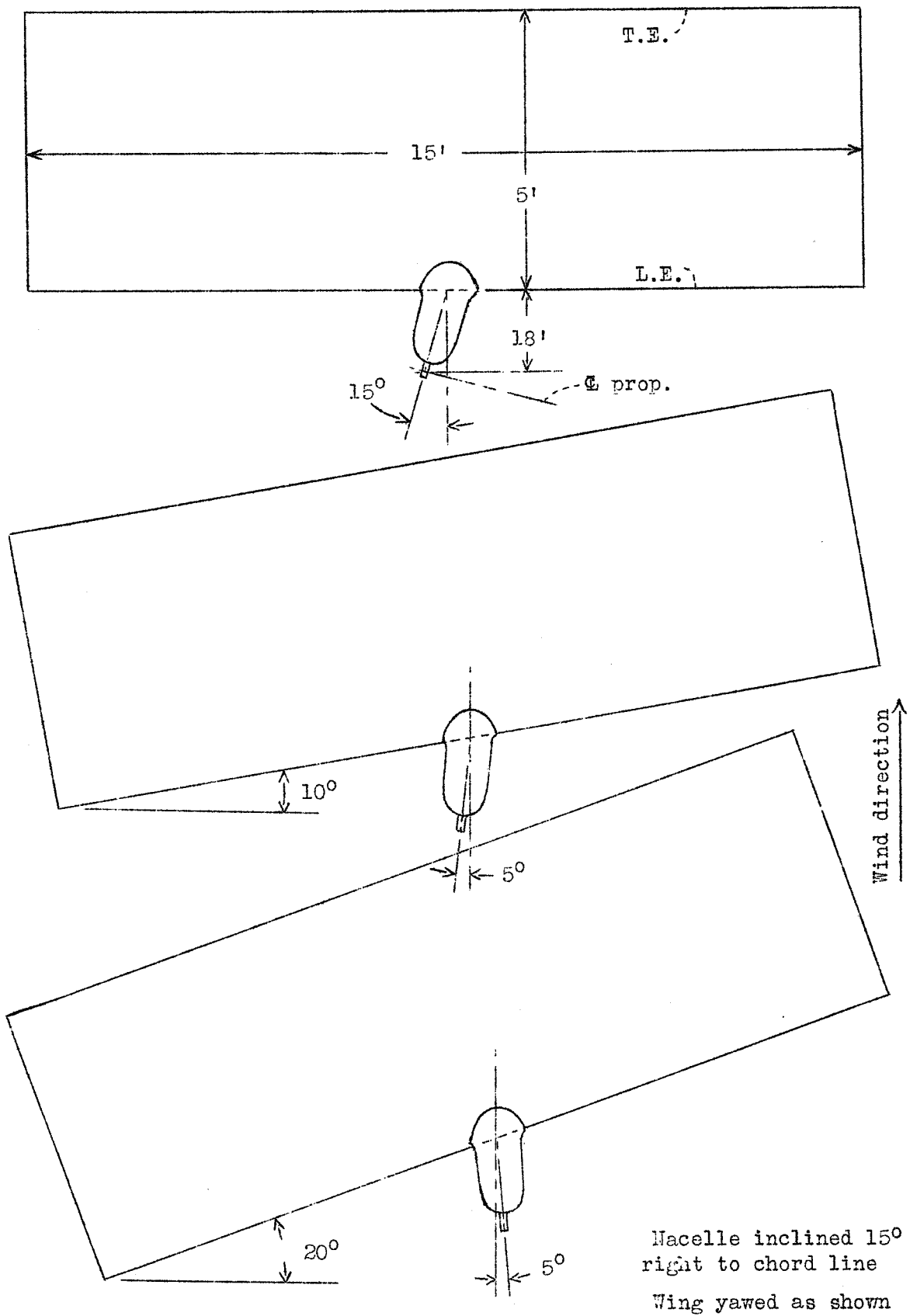

Figure 2.-Nacelle 15° to chord; wing -20° yaw.



Nacelle parallel to
chord line.
Wing yawed as shown

Figure 3.



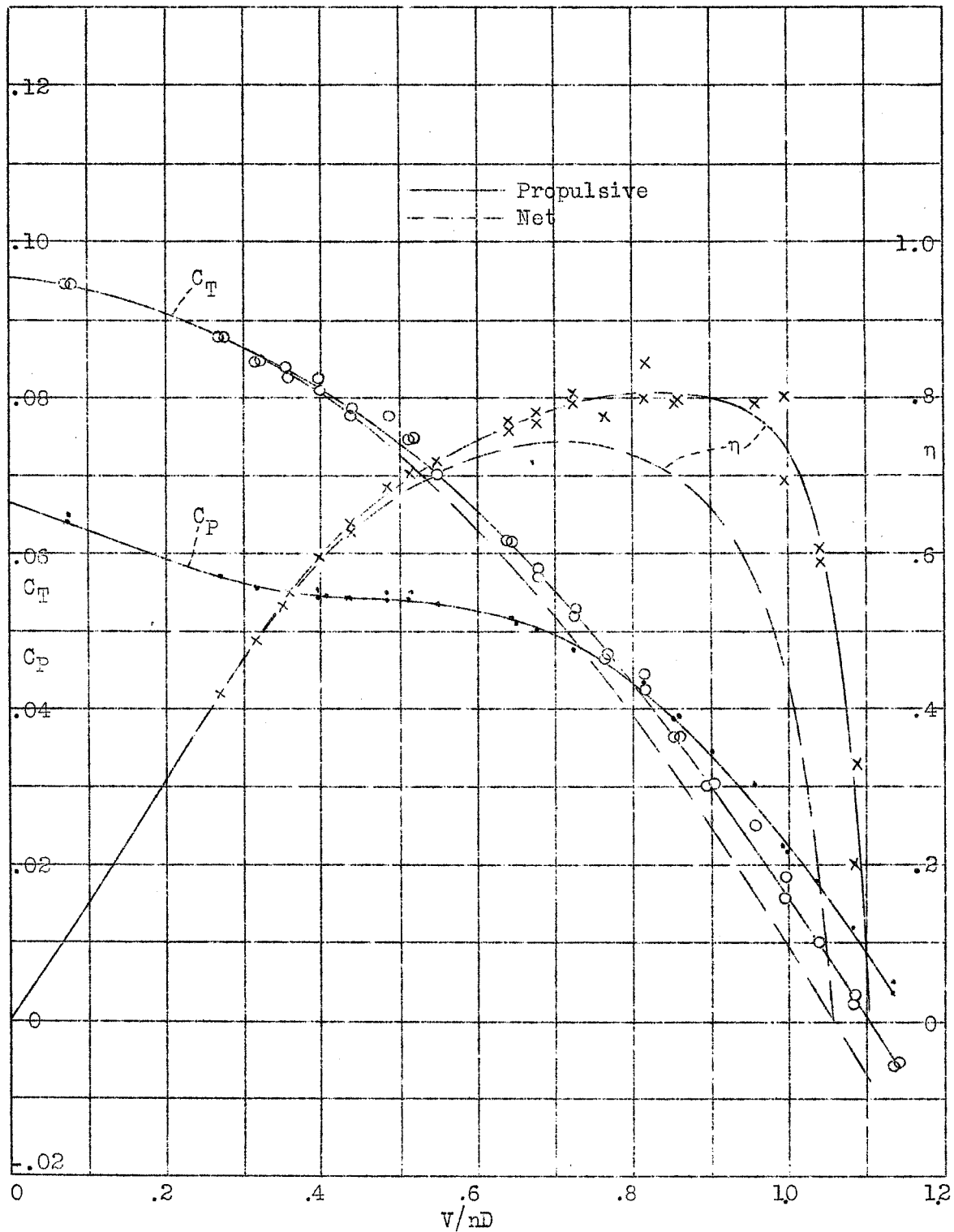

Figure 5.- Macelle parallel to chord; wing 0° yaw, R.H. propeller No. 4412, Dia. 4 ft., Set 22° , at .75R.

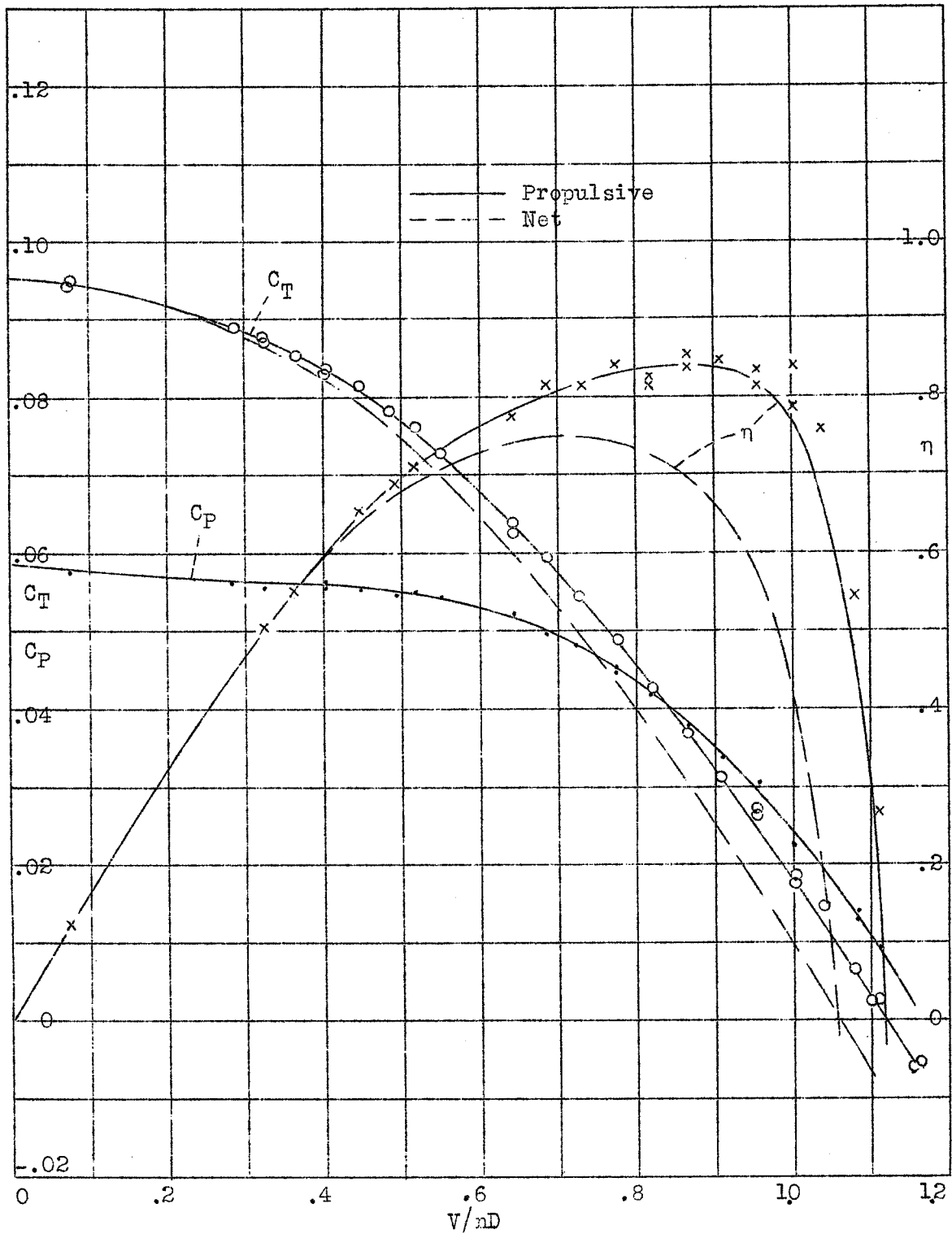

Figure 6.- Nacelle parallel to chord; wing -5° yaw, R.H. propeller No. 4412, Dia. 4 ft., Set 22° , at $.75R$.

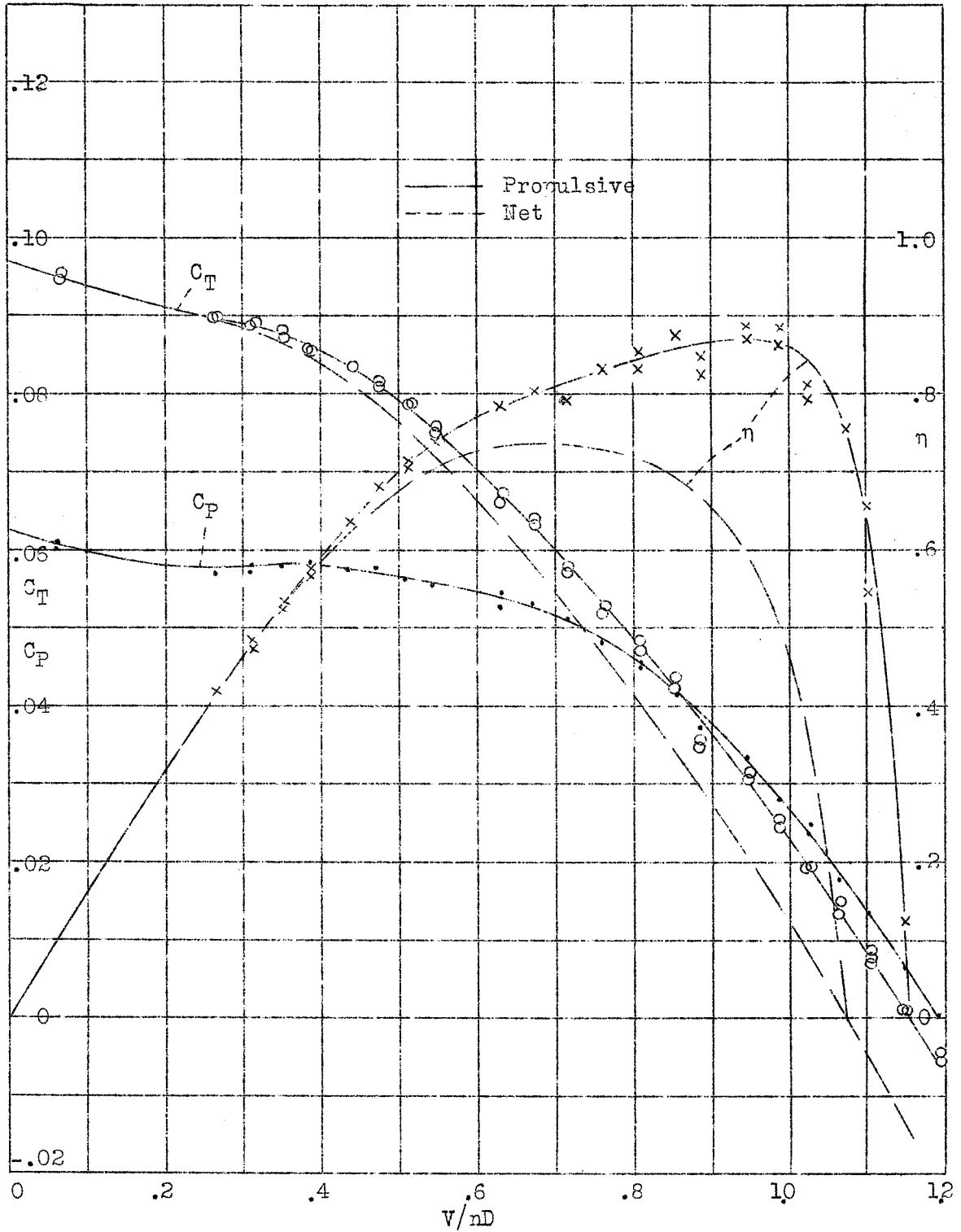

Figure 7.- Nacelle parallel to chord; wing -10° yaw, R.H. propeller No. 4412, Dia. 4 ft., Set 22° , at .75R.

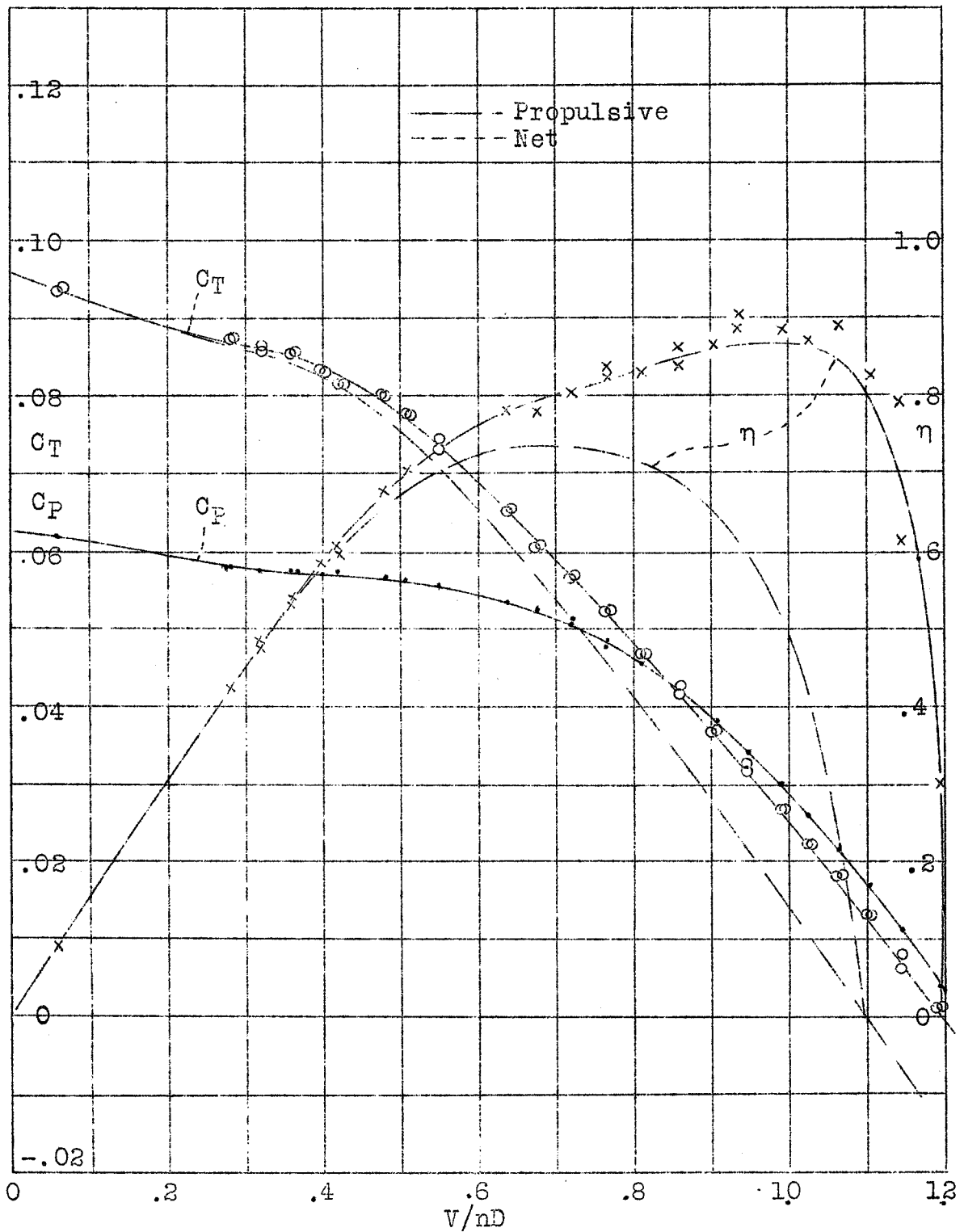

Figure 8.- Nacelle 15° to chord; wing 0° yaw, R.H. propeller No. 4412, Dia. 4 ft, Set 23° , at .75 R.

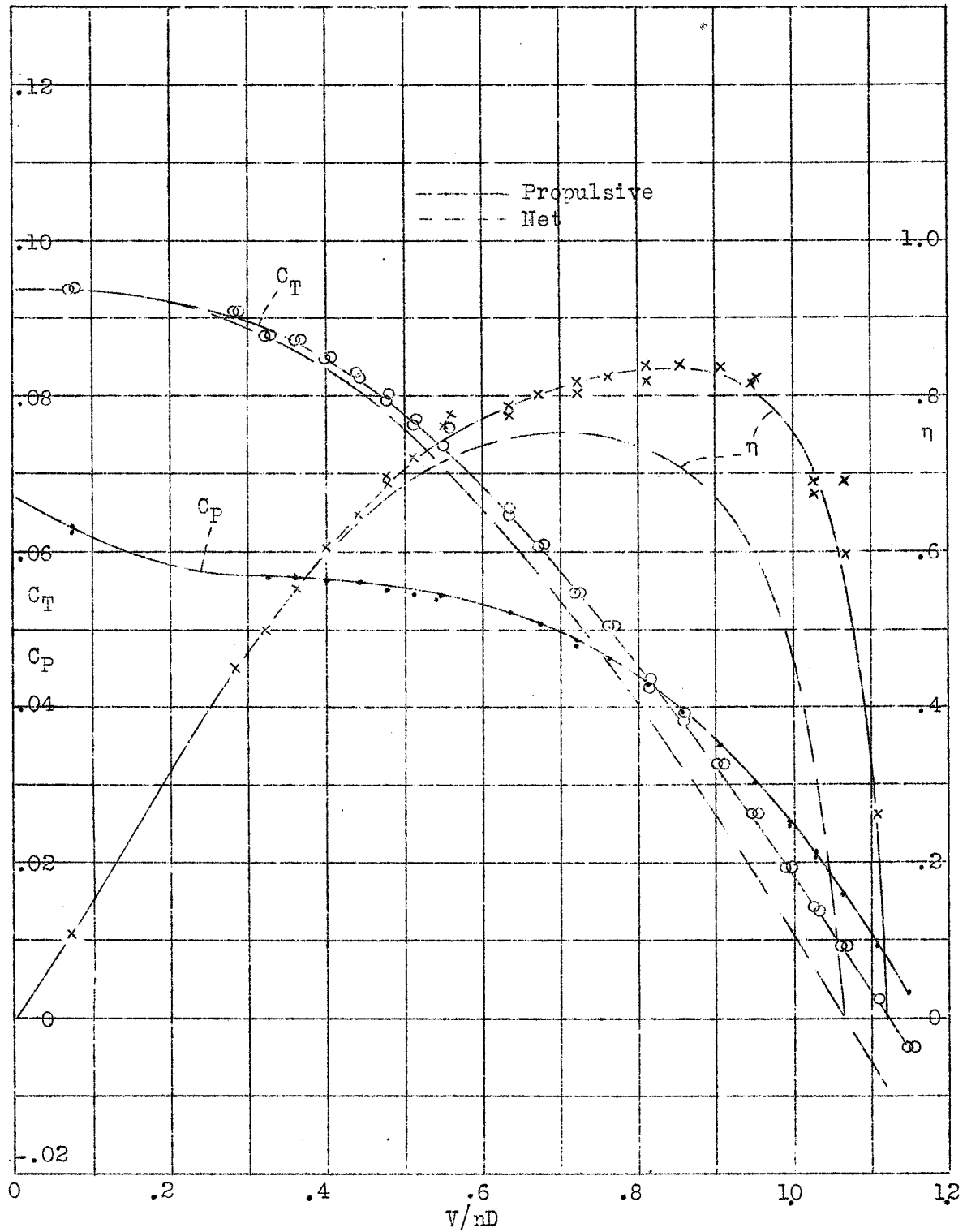

Figure 9.- Nacelle 15° to chord; wing -10° yaw, R.H. propeller No. 4412, Dia. 4 ft., Set 22° , at .75R.

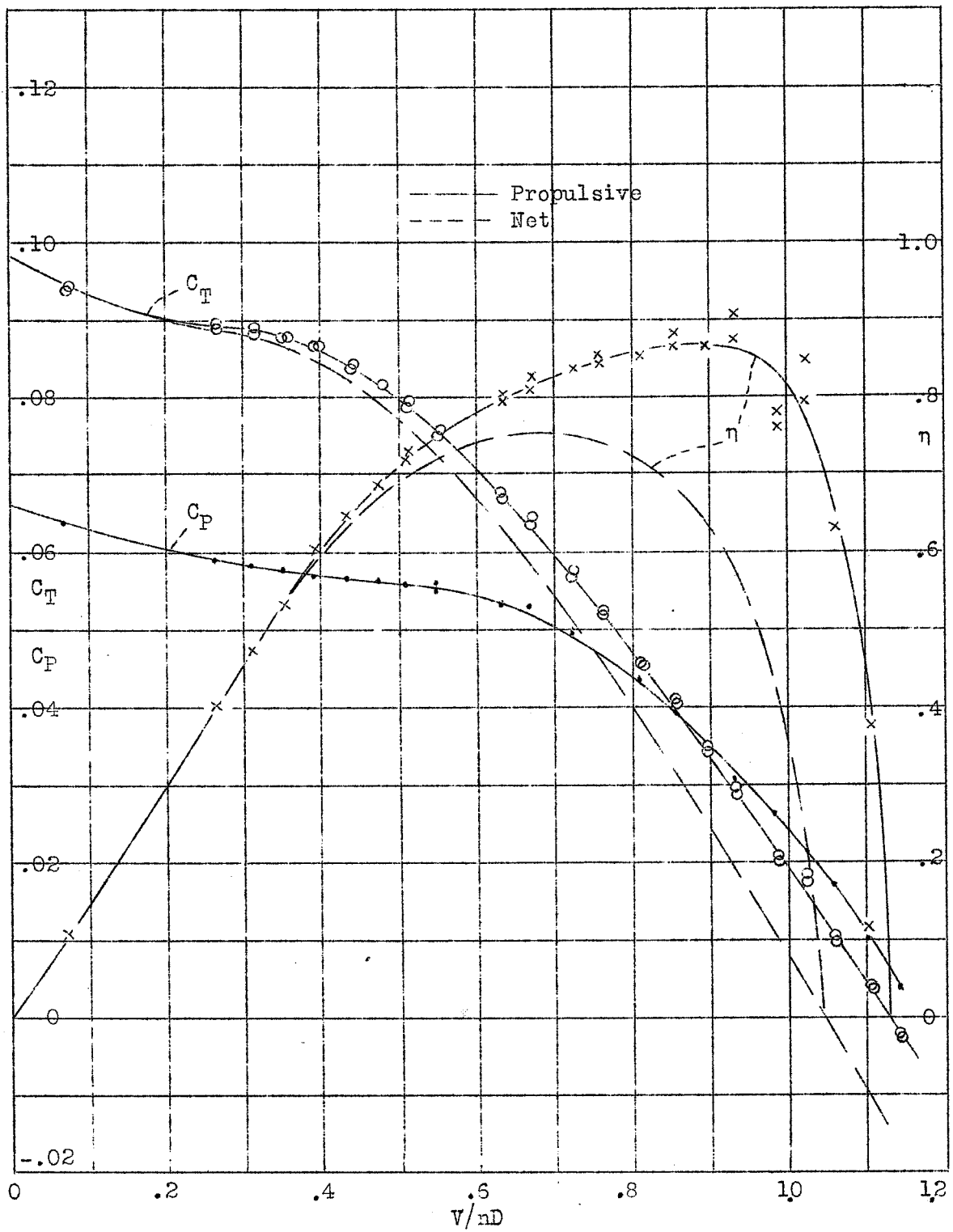

Figure 10.- Nacelle 15° to chord; wing -20° yaw, R.H. propeller No. 4412, Dia. 4 ft., Set 22° , at $.75R$.

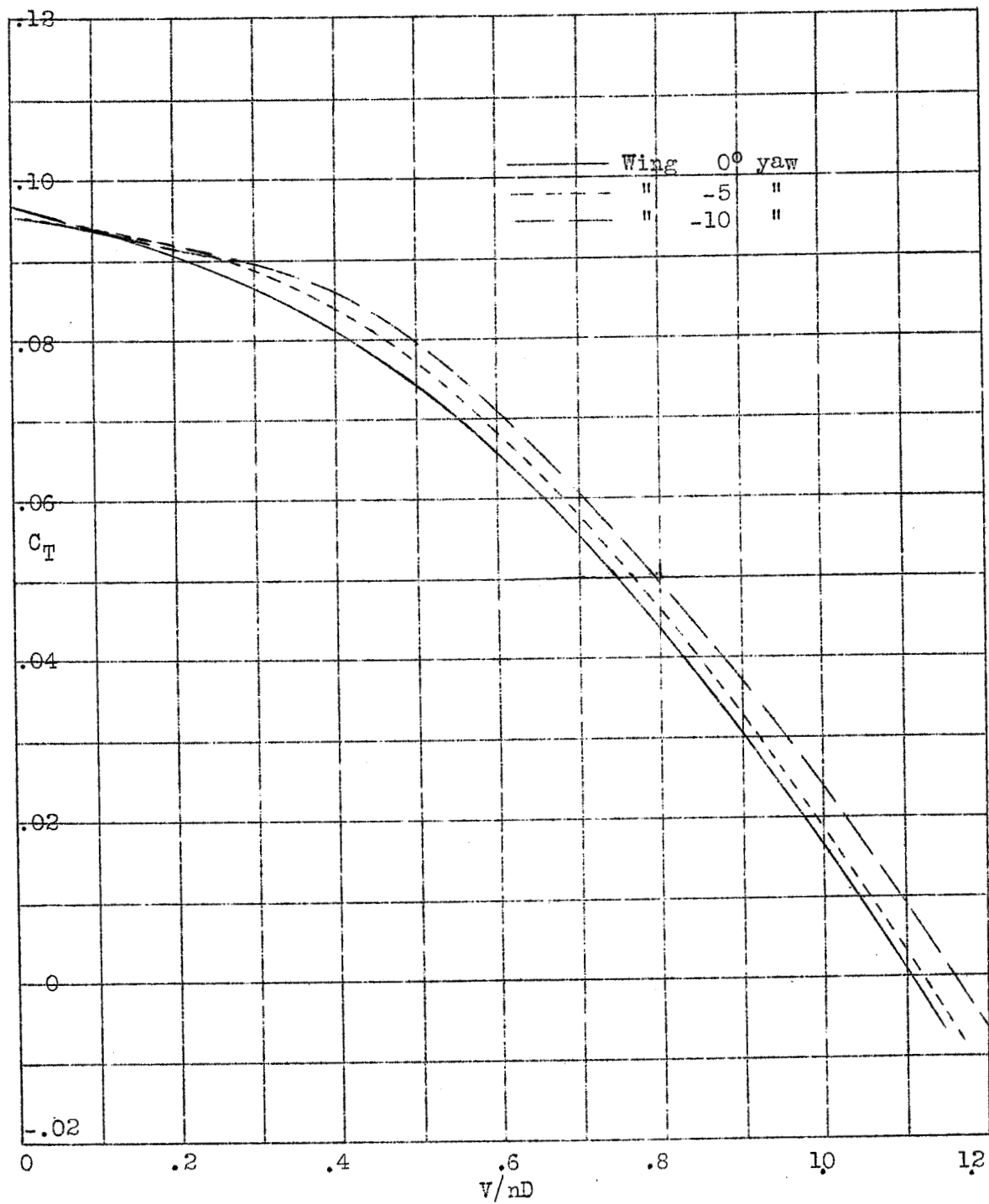

Figure 11.- Nacelle parallel to chord; propulsive thrust, R.H. propeller No. 4412, Dia. 4 ft., Set 28° , at .75R.

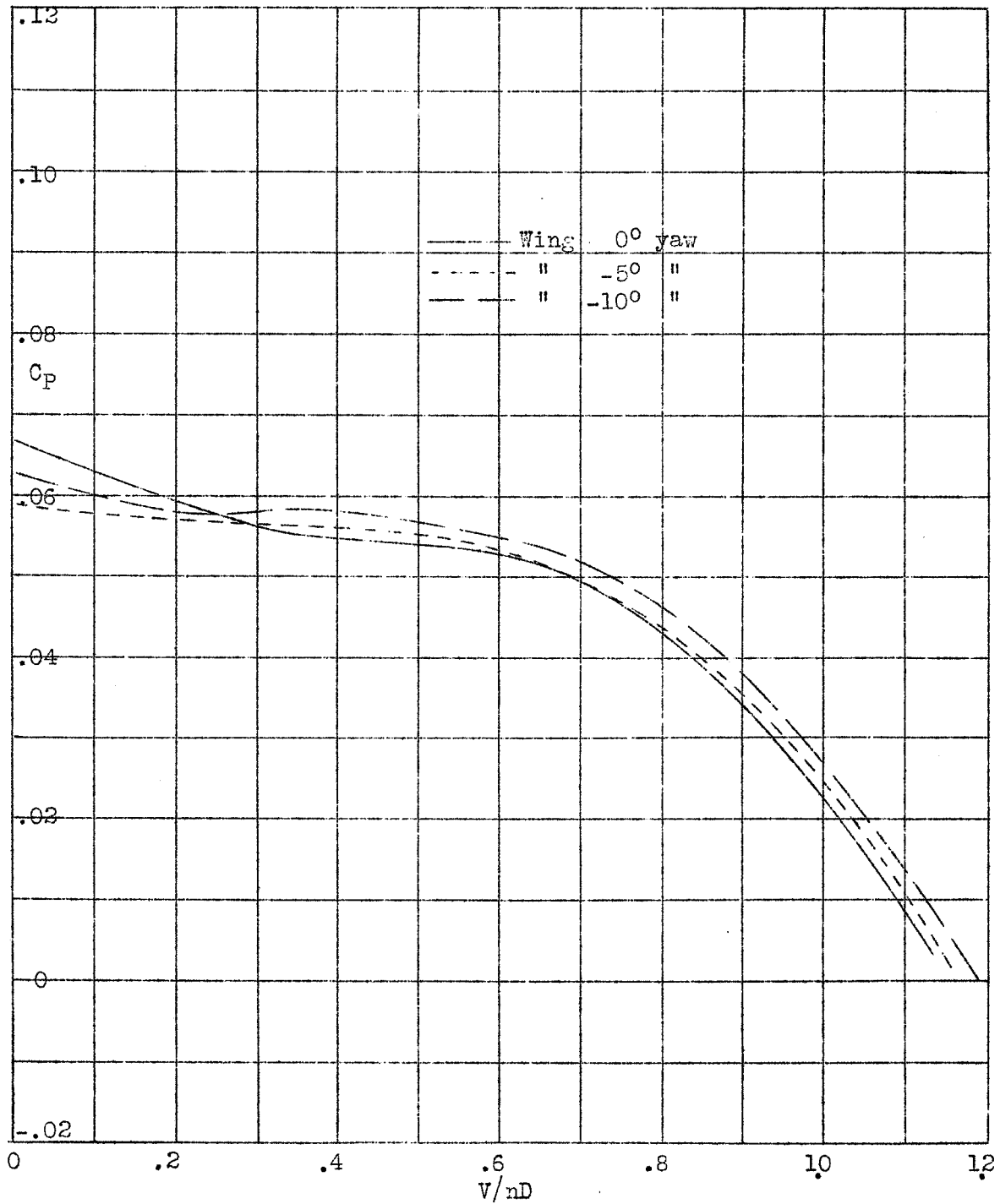

Figure 12.- Nacelle parallel to chord; power, R.H. propeller No. 4412, Dia. 4 ft., Set 22°, at .75R.

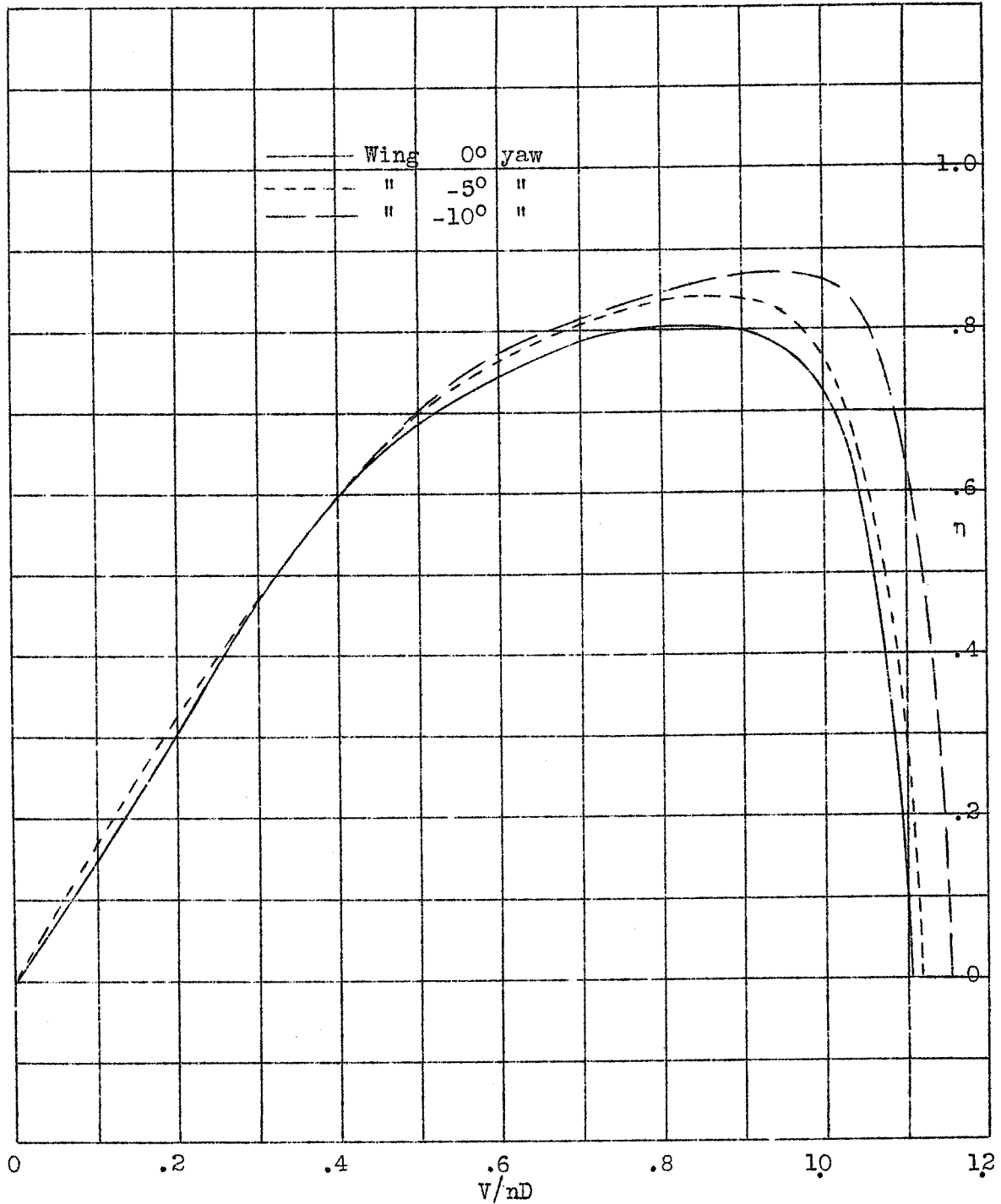

Figure 13.- Nacelle parallel to chord; propulsive efficiency, R.H. propeller No. 4412, Dia. 4 ft., Set 22°, at .75R.

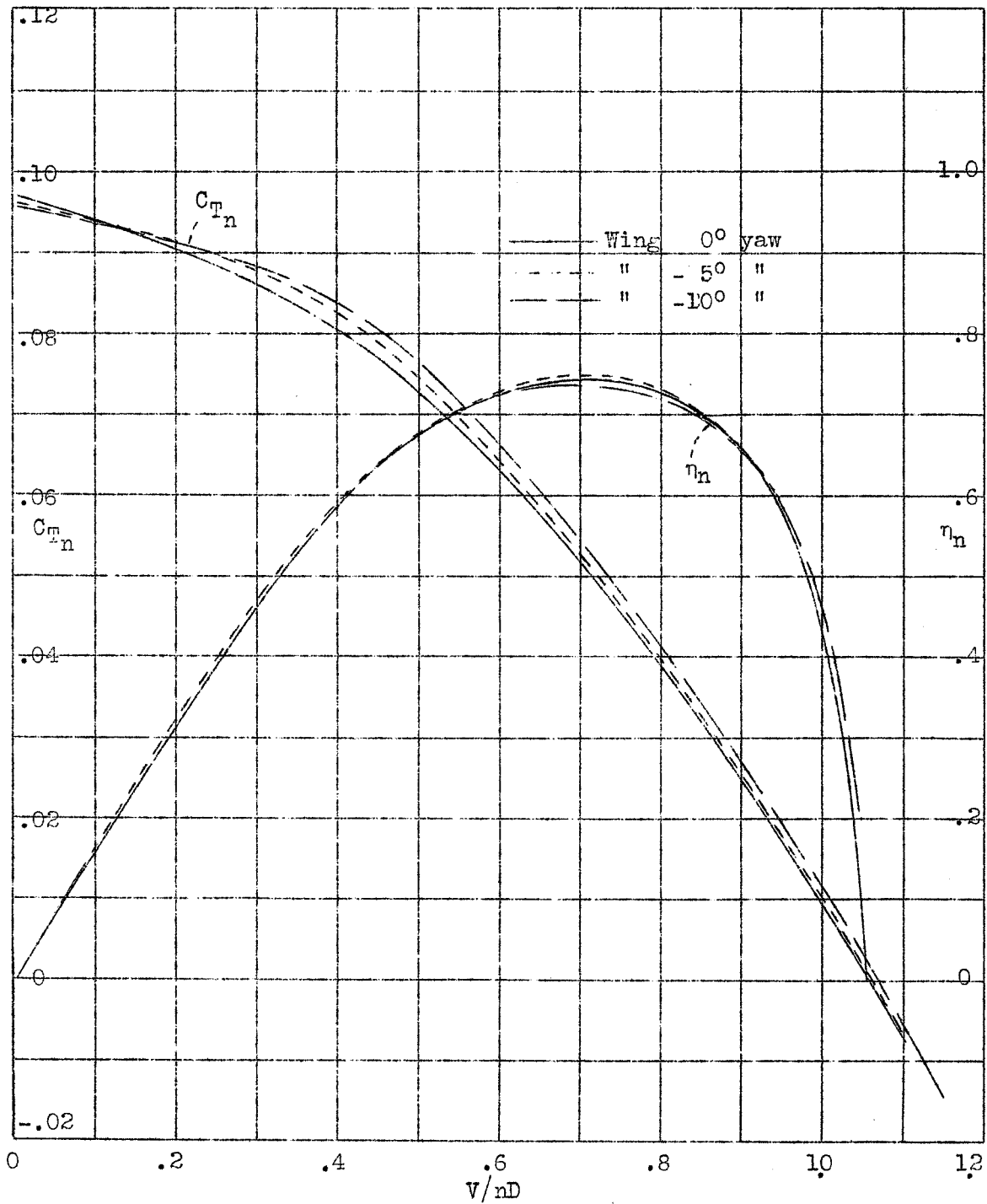

Figure 14.- Nacelle parallel to chord; net thrust and efficiency, R.H. propeller No. 4412, Dia. 4 ft., Set 22°, at .75R.

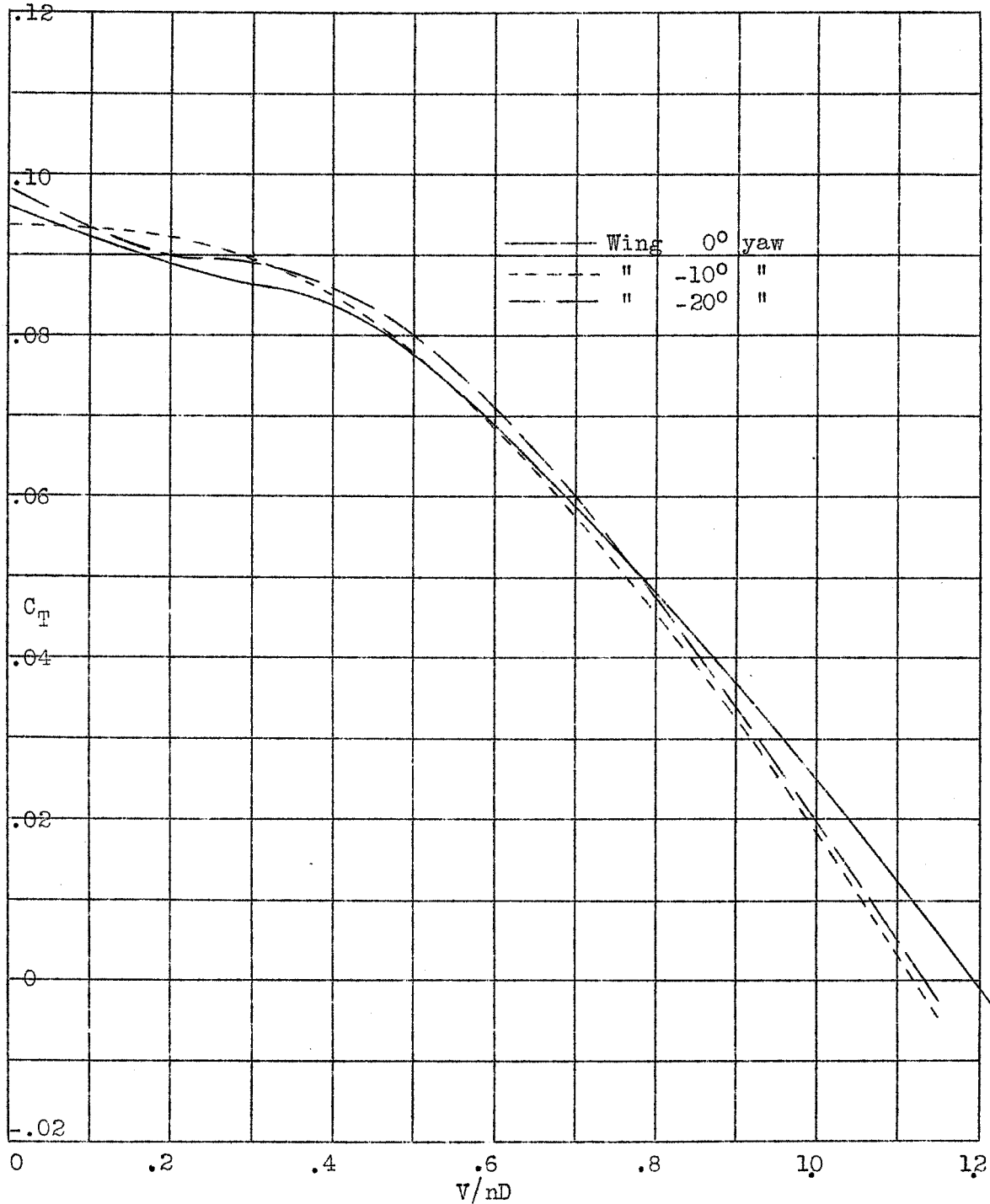

Figure 15.- Nacelle 15° to chord; propulsive thrust, R.H. propeller No. 4412, Dia. 4 ft., Set 22° , at $.75R$.

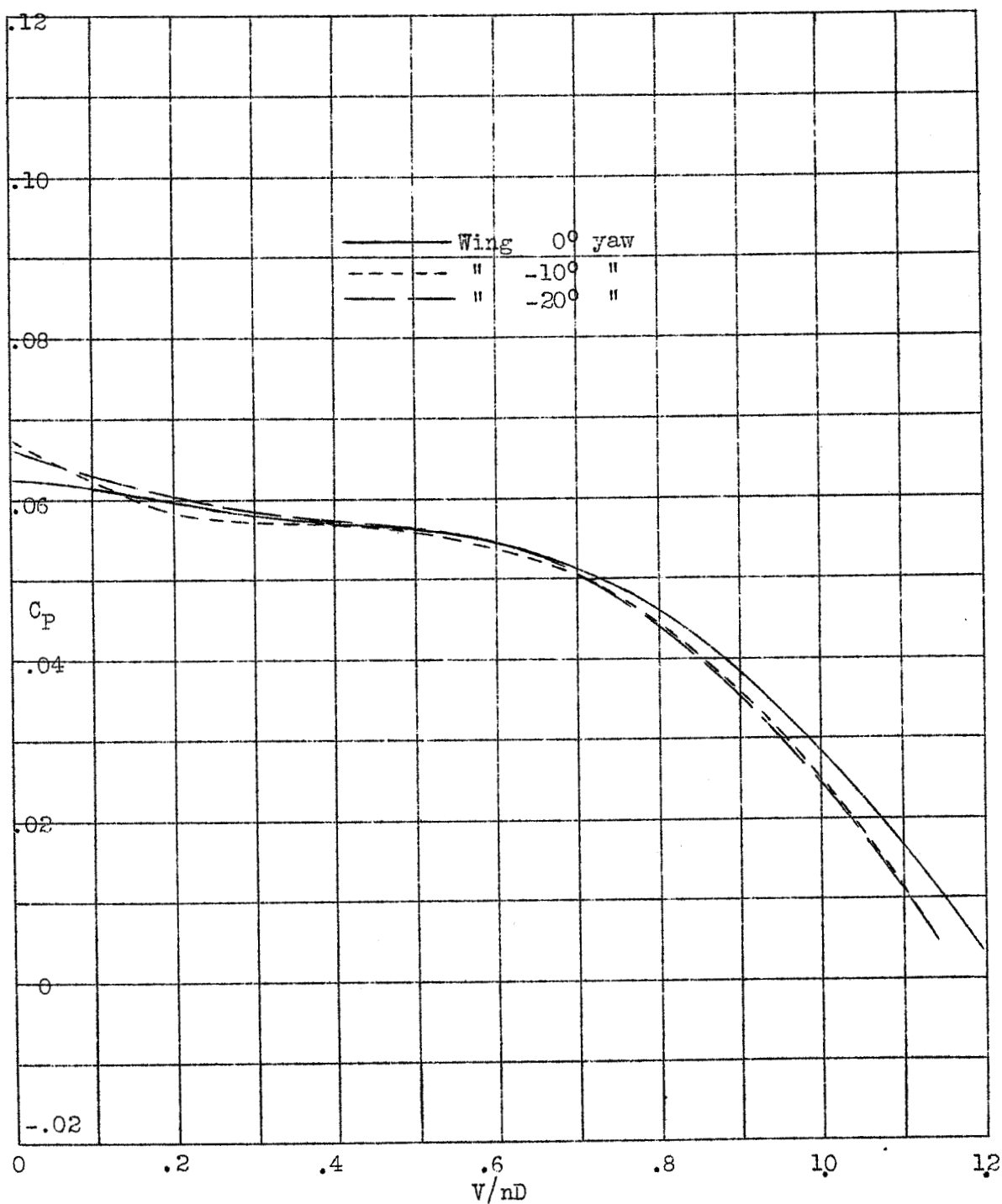

Figure 16.- Nacelle 15° to chord; power, R.H. propeller No. 4412, Dia. 4 ft., Set 22°, at .75R.

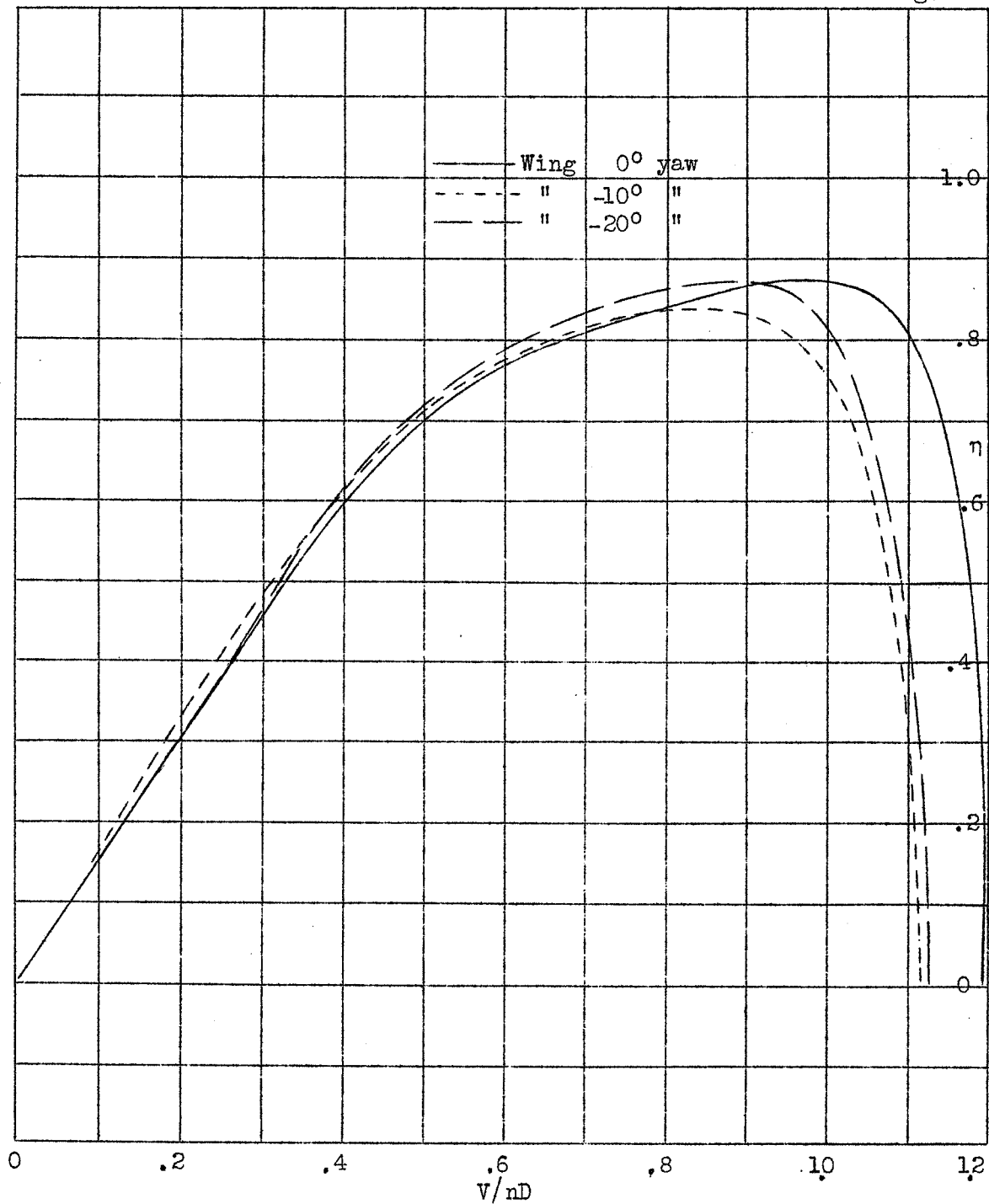

Figure 17.- Nacelle 15° to chord; propulsive efficiency, R.H. propeller No. 4412, Dia 4 ft., Set 22°, at .75R.

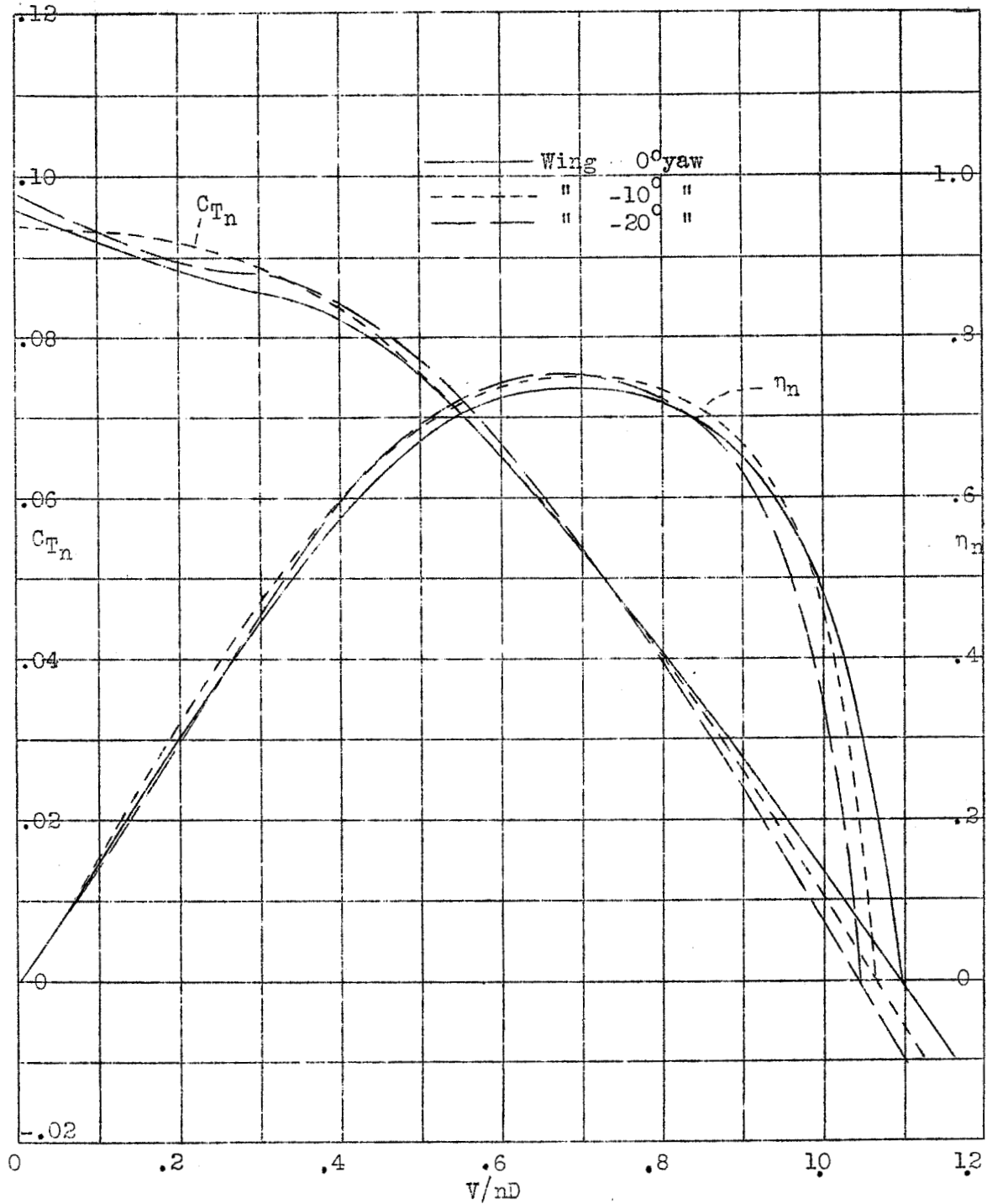

Figure 18.- Nacelle 15° to chord; net thrust and efficiency, R.H. propeller No. 4412, Dia 4 ft., Set 22° , at .75R.

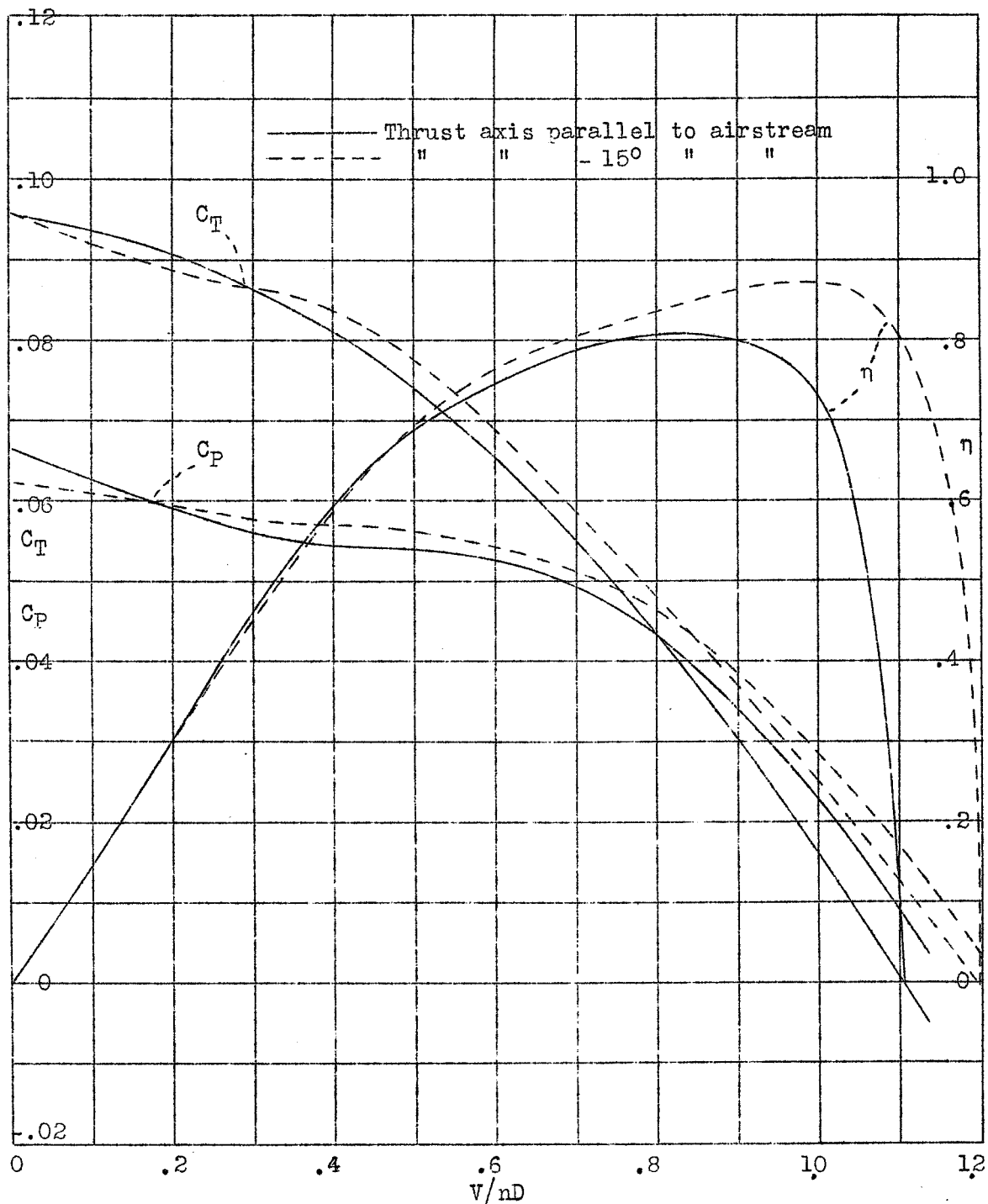

Figure 19.- Wing 0° yaw; propulsive curves, R.H. propeller No. 4412, Dia. 4 ft., Set 22° , at .75R .

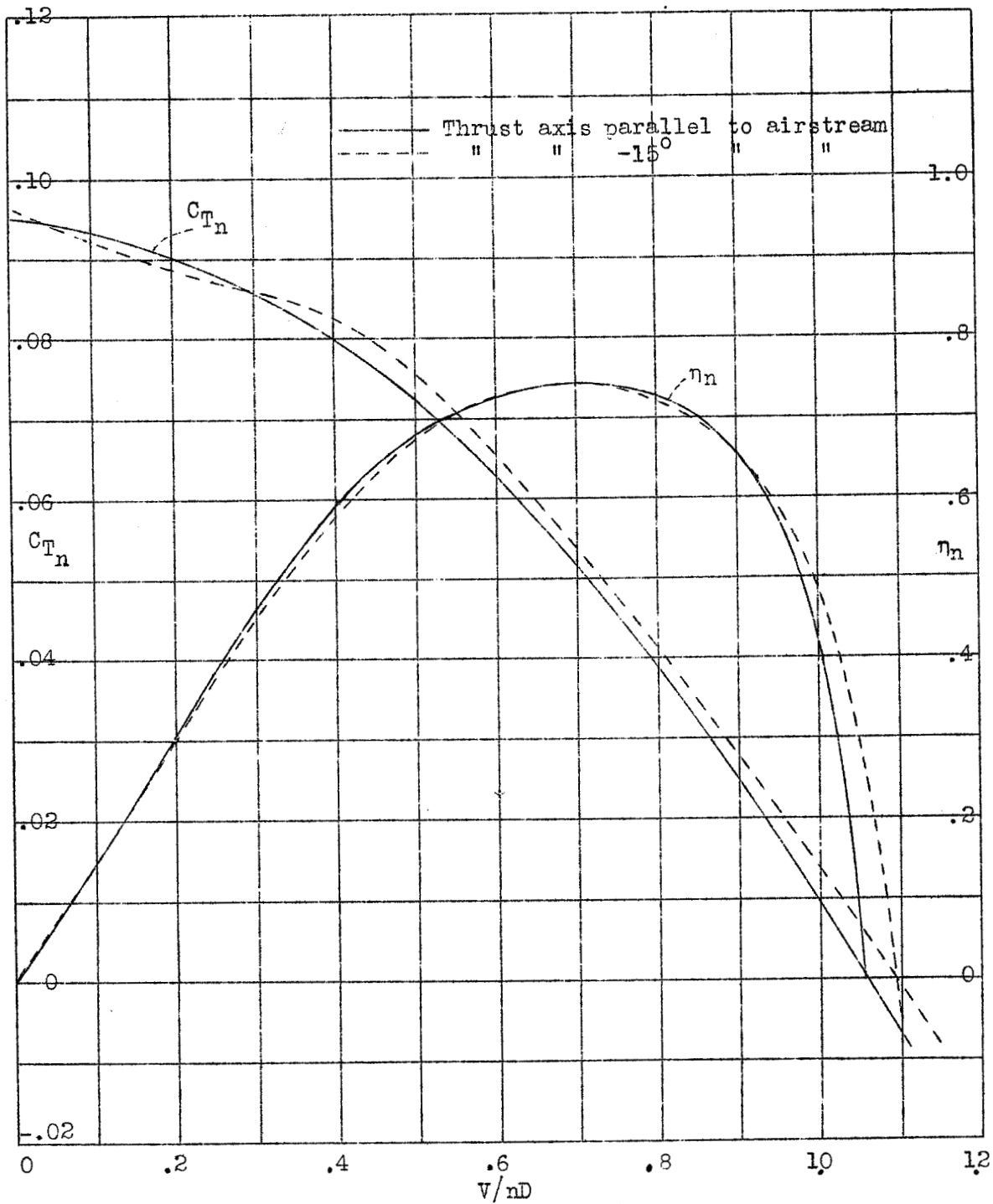

Figure 20.- Wing 0° yaw; net curves, R.H. propeller No. 4412, Dia. 4 ft., Set 22° , at $.75R$.

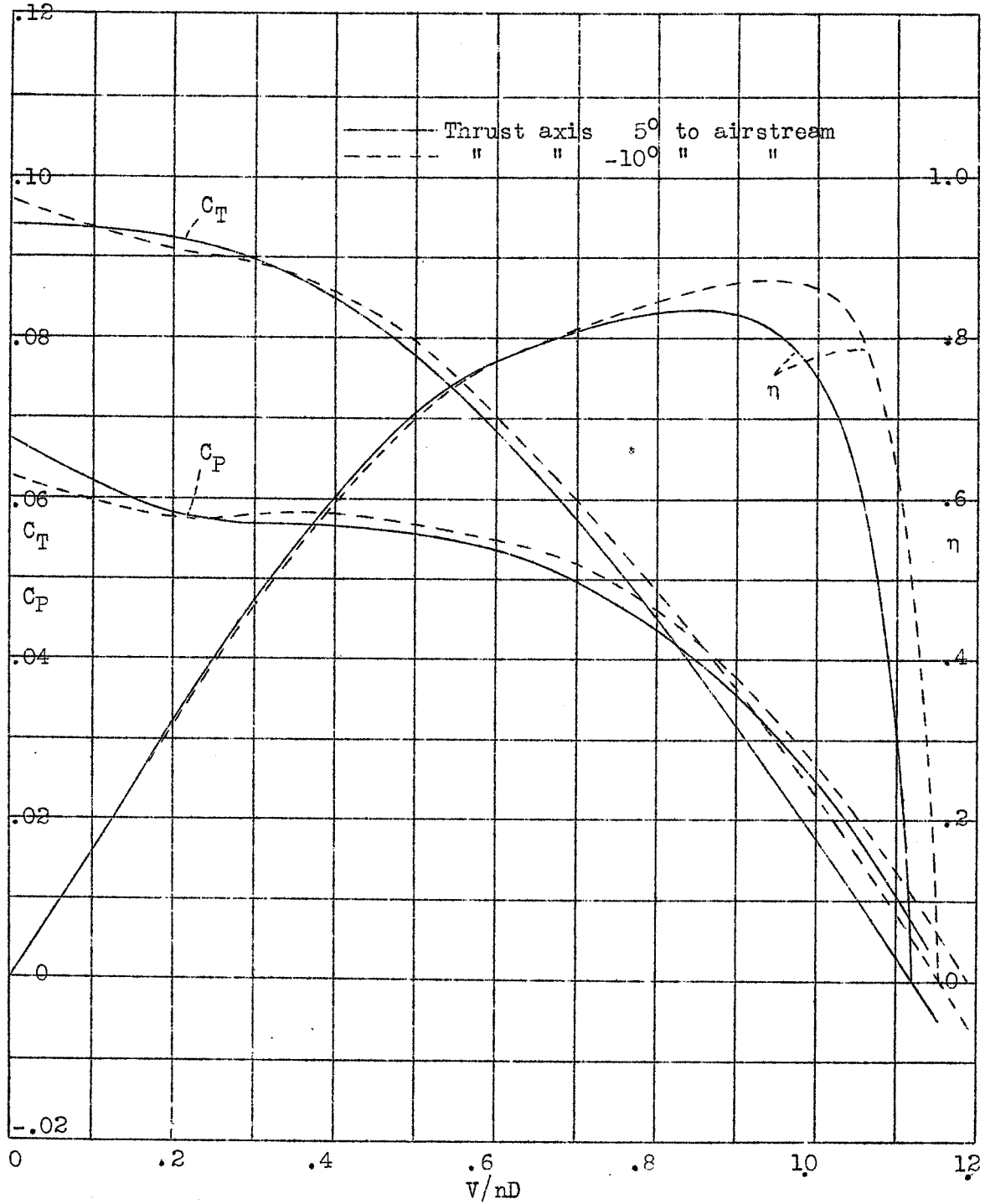

Figure 21.- Wing -10° yaw; propulsive curves, R.H. propeller No. 4412, Dia. 4 ft., Set 22° , at .75R.

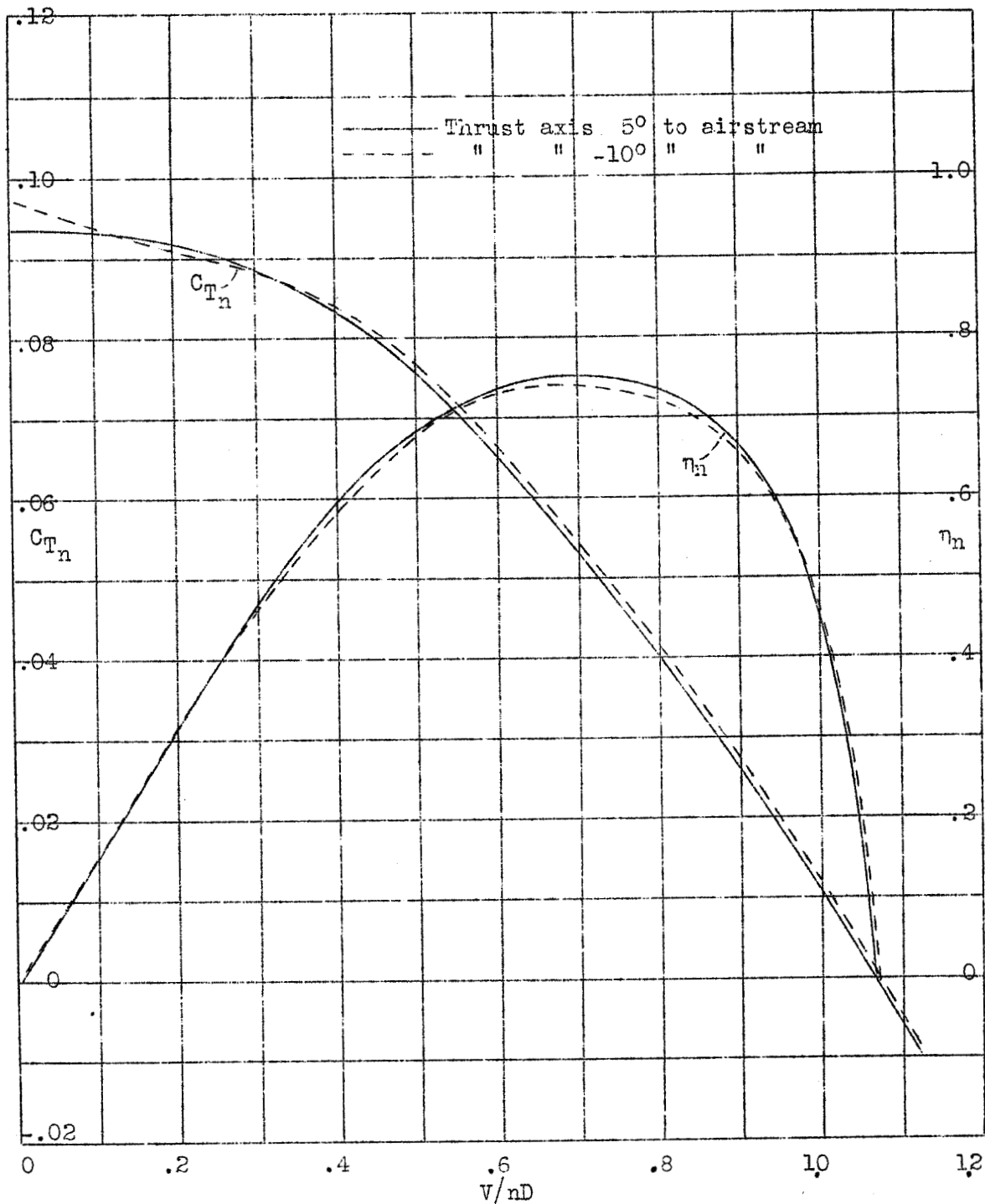

Figure 22.- Wing -10° yaw; net curves, R.H. propeller No. 4412, Dia. 4 ft., Set 22° , at .75 R.

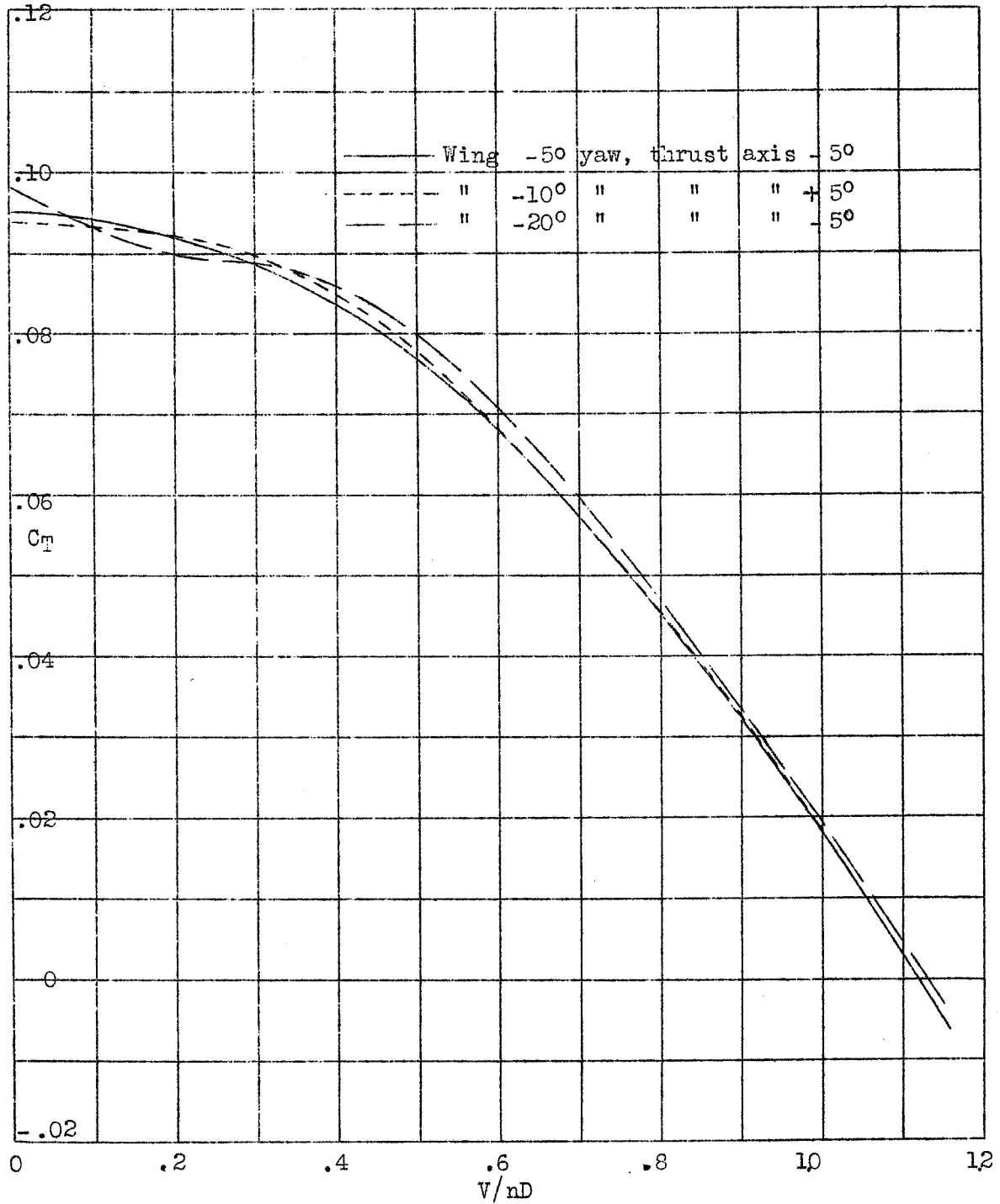

Figure 23.- Thrust axis inclined 5°; propulsive thrust coefficient, R.H. propeller No. 4412, Dia 4 ft., Set 22°, at .75R.

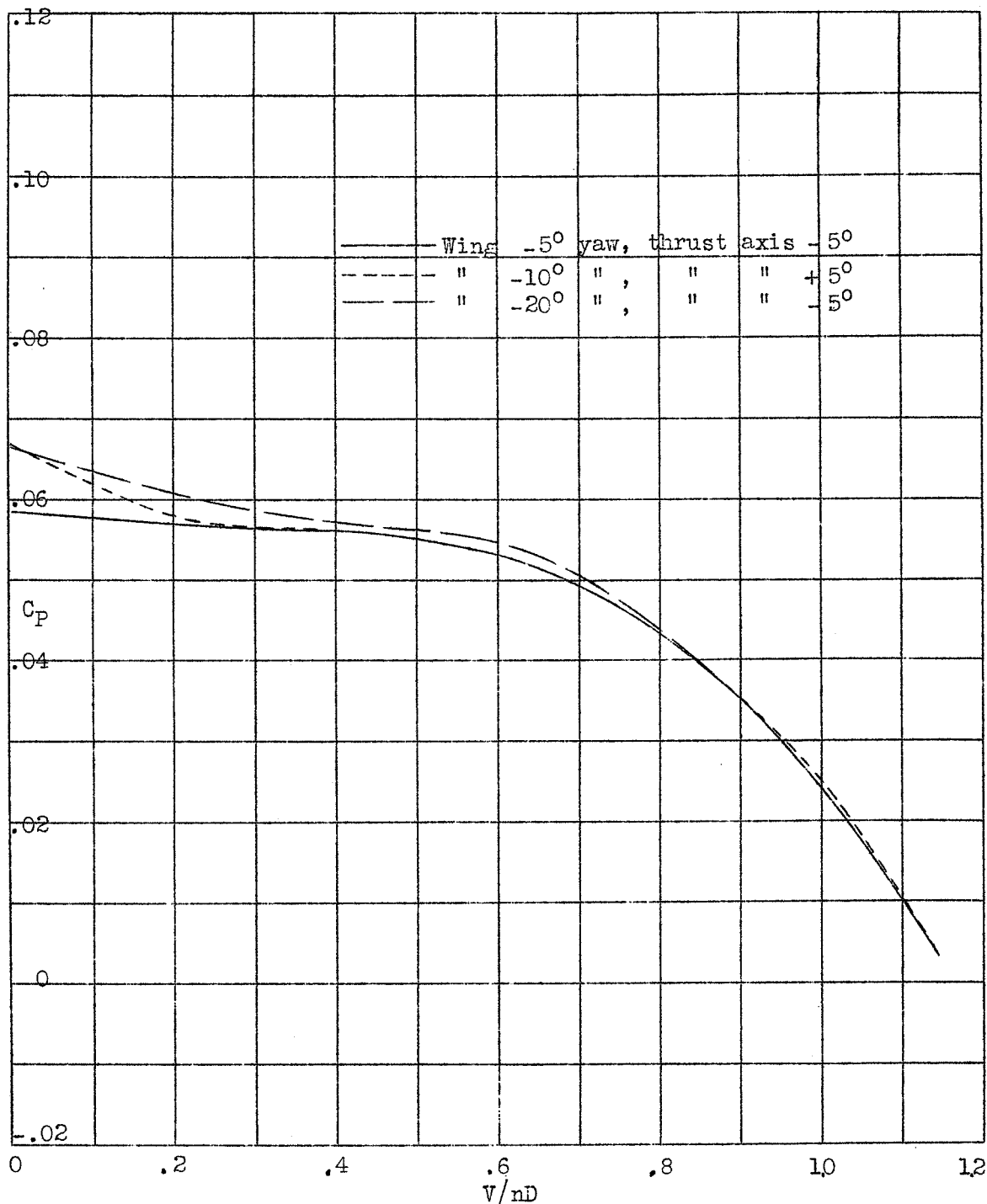

Figure 24.- Thrust axis inclined 5° ; power coefficient, R.H. propeller No. 4412, Dia. 4 ft., Set 22° , at $.75R$.

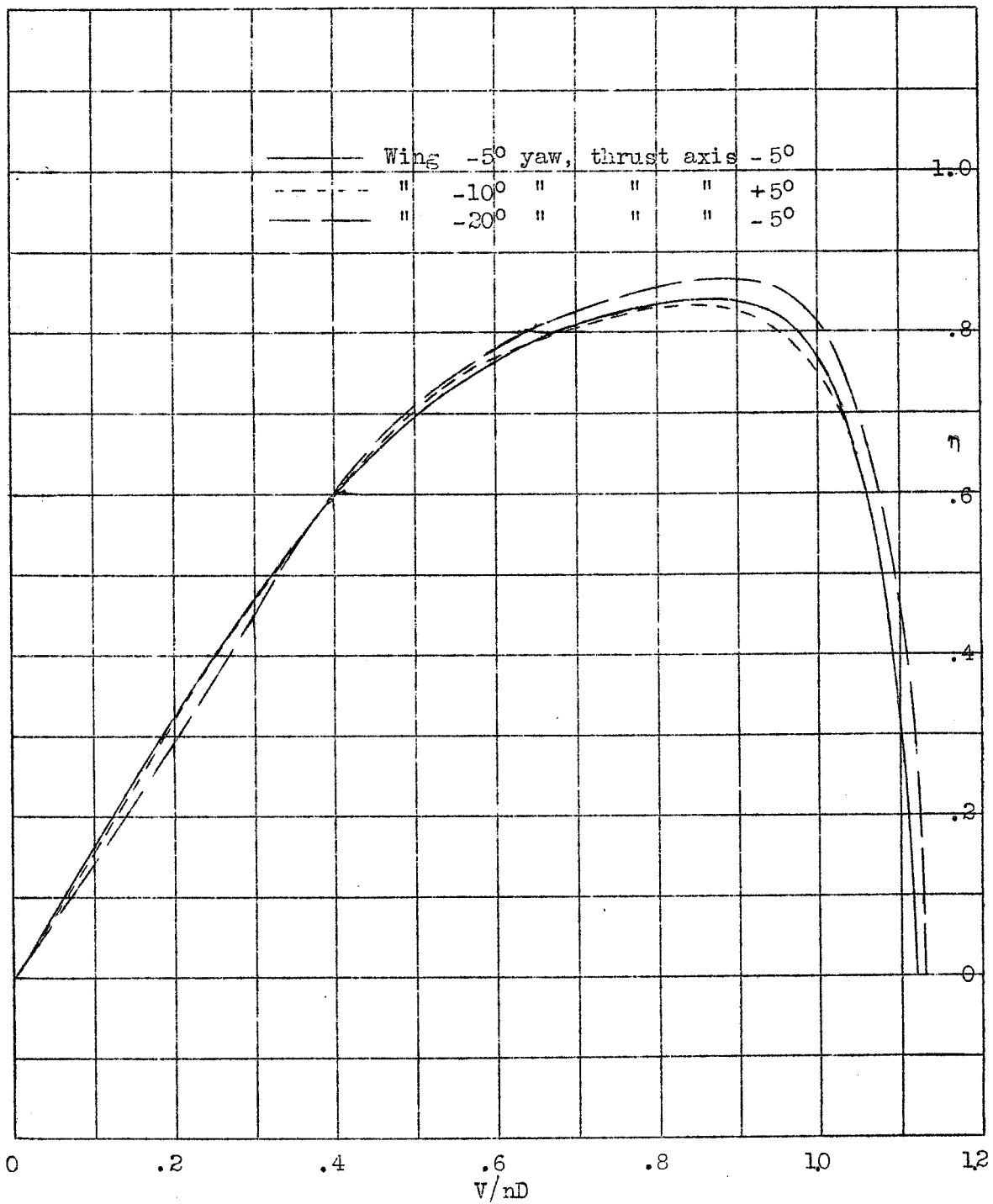

Figure 25.- Thrust axis inclined 5° ; propulsive efficiency, R.H. propeller No. 4412, Dia. 4 ft., Set 22° , at .75R.

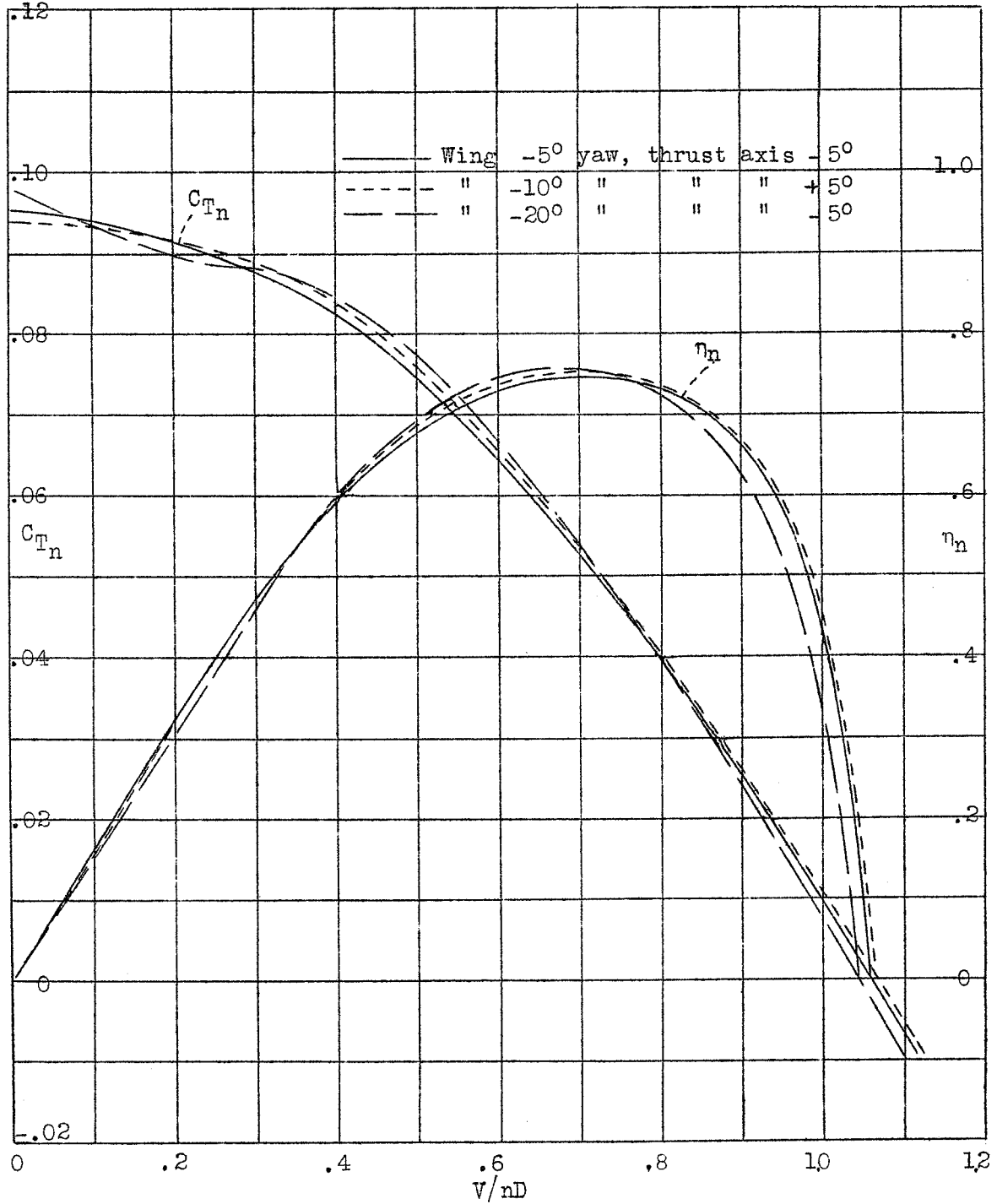

Figure 26.- Thrust axis inclined 5° ; net thrust and efficiency, R.H. propeller No. 4412, Dia. 4 ft., Set 22° , at .75R.