

THERMAL (SILICON DIODE) DATA ACQUISITION SYSTEMS

Ernest Wright and Jeff Kegley
NASA Marshall Space Flight Center

ABSTRACT

Marshall Space Flight Center's X-ray Cryogenic Facility (XRCF) has been performing cryogenic testing to 20 Kelvin since 1999. Two configurations for acquiring data from silicon diode temperature sensors have been implemented at the facility. The facility's environment is recorded via a data acquisition system capable of reading up to 60 silicon diodes. Test article temperature is recorded by a second data acquisition system capable of reading 150+ silicon diodes. The specifications and architecture of both systems will be presented.

INTRODUCTION

Beginning in 1999, the Marshall Space Flight Center (MSFC) X-ray Cryogenic Facility (XRCF) began performing sub-liquid nitrogen temperature cryogenic optical and structural testing. Historically the facility employed thermocouples or thermistors to measure temperature; however, the lower temperatures now being achieved dictated the need for another type of sensor. While the test article target temperature is usually no less than 20 Kelvin, the facility environment is capable of about 8 Kelvin. After considering factors such as availability, durability, packaging size and options, cost, temperature range, high vacuum compatibility, and interchangeability - the silicon diode was selected.

While several methods can be used to acquire data from silicon diode sensors, the XRCF utilizes two distinct silicon diode data acquisition systems. The first system is used to acquire the temperature data of the facility's environment. A diagram of this environment is shown in Figure 1. The second system is used to acquire the temperature data of the test article and test support equipment. Both systems transmit data to the existing XRCF data archival system.

FACILITY ENVIRONMENT DATA SYSTEM

Requirements

Requirements for the temperature measurement of the XRCF helium-cooled enclosure are not very stringent. Generally, an indicated temperature within ± 1 Kelvin of actual (< 100 K) will be sufficient. This requirement allowed the use of two-wire diode systems and uncalibrated sensors with standard response curves.

Configuration

The facility environment data acquisition system is shown in Figure 2. The system can be described by beginning at the sensor location. The sensor is a 2-wire silicon diode packaged in a 14.3 diameter disk. This disk is mechanically attached to the surface of the helium enclosure. The 30-AWG leads from the sensor are then wrapped around an aluminum bobbin that is in good contact with the helium enclosure; this heat sinks the leads to ensure that no parasitic heat is reaching the sensor via the leads. The leads then terminate in a 2-pin connector. This connector's mate is part of the helium enclosure's 22 AWG wiring harness that terminates in an intermediate connector in an accessible location on each helium enclosure element. This intermediate connector couples each enclosure element's wiring harness to the chamber's hermetically-sealed electrical wiring feedthrough.

Outside the chamber the feedthrough wiring continues to the data acquisition rack where it is broken out and connected to the scanner and current source channels.

Data Acquisition System

The Lakeshore® Model 120 current source was chosen to provide the necessary excitation current to the diodes. Each current source is shared between six diodes – this is driven by the compliance voltage (11 volts). Shunt or shorting toggle switches were installed so that a single diode failure would not necessitate the loss of five others.

The Agilent® Model 34970A Data Acquisition Switch Unit (with 3 each Model 34901A twenty-channel multiplex modules) was chosen to read the voltage output from the sensors and transmit the result to the XRCF data storage system. The scanner's Digital Multimeter (DMM) resolution setting can be varied; scan time increases with increased resolution. The XRCF scan settings are such that the scanner transmits the voltage response from all 60 channels via GPIB (IEEE488) to the XRCF data storage system every 120 seconds. The XRCF data storage system applies the appropriate standard silicon diode response curve to the voltage data to store and display the corresponding temperature values.

TEST ARTICLE DATA SYSTEM

Requirements

Requirements for the XRCF test article data acquisition system were developed for a very specific test program. For this program, the ability to resolve temperature changes and the differential accuracy between diodes were more important than individual measurement absolute accuracy. The number of channels required was 150. The multiplexing unit and the temperature monitor were both considered for use. Trade study elements included DMM accuracy, acquisition rate, simplicity of implementing calibration data for individual diodes, and impact of unit failures. The Lakeshore® temperature monitor was selected for use in this particular case.

Configuration

The test article data acquisition system is shown in Figure 3. The system can be described by beginning at the sensor location. The customer-provided sensor is a 4-lead silicon diode packaged in a small (< 4mm chip). This chip is mechanically attached to the surface of the test article by the customer. The 30-AWG leads from the sensor are then taped to the surface of the test article for several inches; this heak sinks the leads to ensure that no parasitic heat is reaching the sensor via the leads. The leads then terminate in a 4-pin connector. This connector's mate is part of the test article's 22 AWG extension cable. This cable is made of four each diode connectors wired to a single 25-pin D connector. This 25-wire (24 utilized) cable arrangement continues through a 36 AWG phosphor-bronze extension cable that crosses the helium enclosure boundary and minimizes the conduction heat leak into the enclosure. This extension cable couples to the chamber's hermetically-sealed electrical feedthrough.

Outside the chamber the feedthrough wiring continues to the data acquisition rack where each 25-pin D connector terminates in a temperature monitor. Each monitor accepts two 25-pin D connectors (8 silicon diode channels).

Data Acquisition System

The Lakeshore® Model 218 eight channel Temperature Monitor was chosen to acquire the data for the test article at the XRCF. Each monitor contains independent excitation current sources for each channel. Each channel is capable of accepting and applying calibration data for a specific diode. Nineteen monitors are required to acquire the 150 channels.

The monitor is capable of transmitting the temperature value for all eight channels via GPIB (IEEE488) to the XRCF data storage system twice per second. The XRCF data system then stores & displays all 150 channels every 30 seconds.

FIGURES

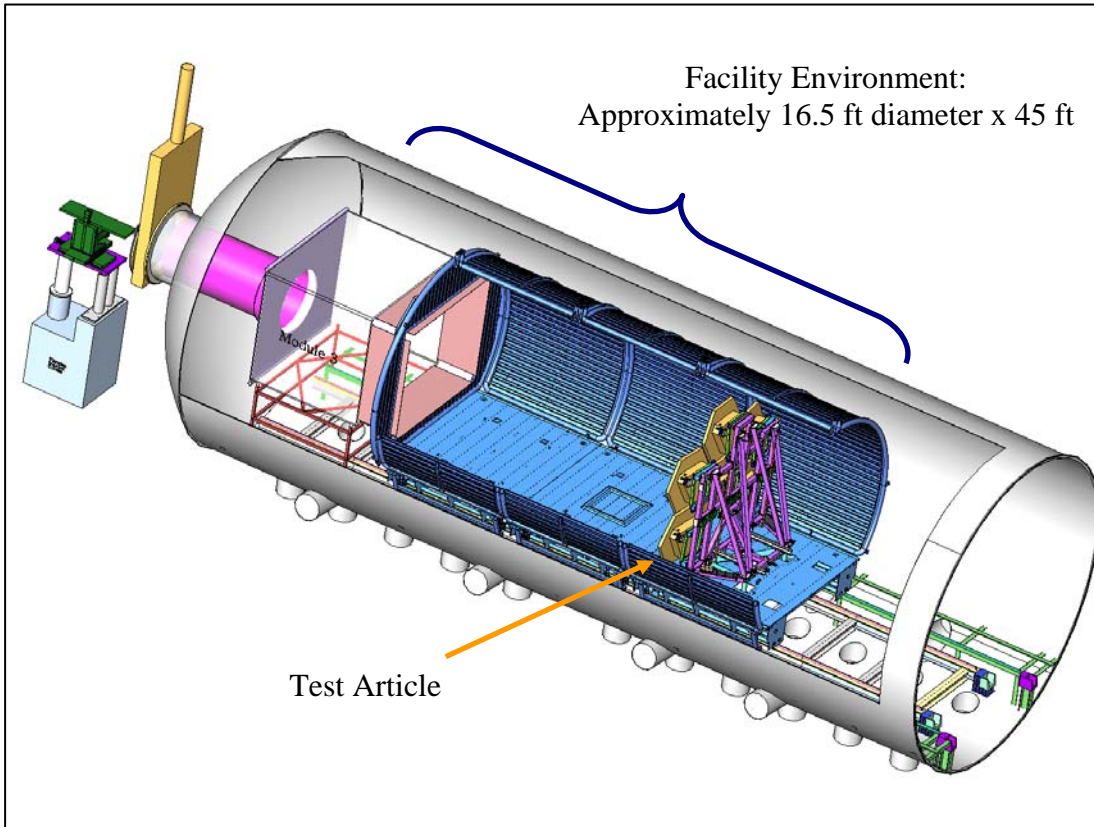

Figure 1: XRCF Helium Cooled Enclosure

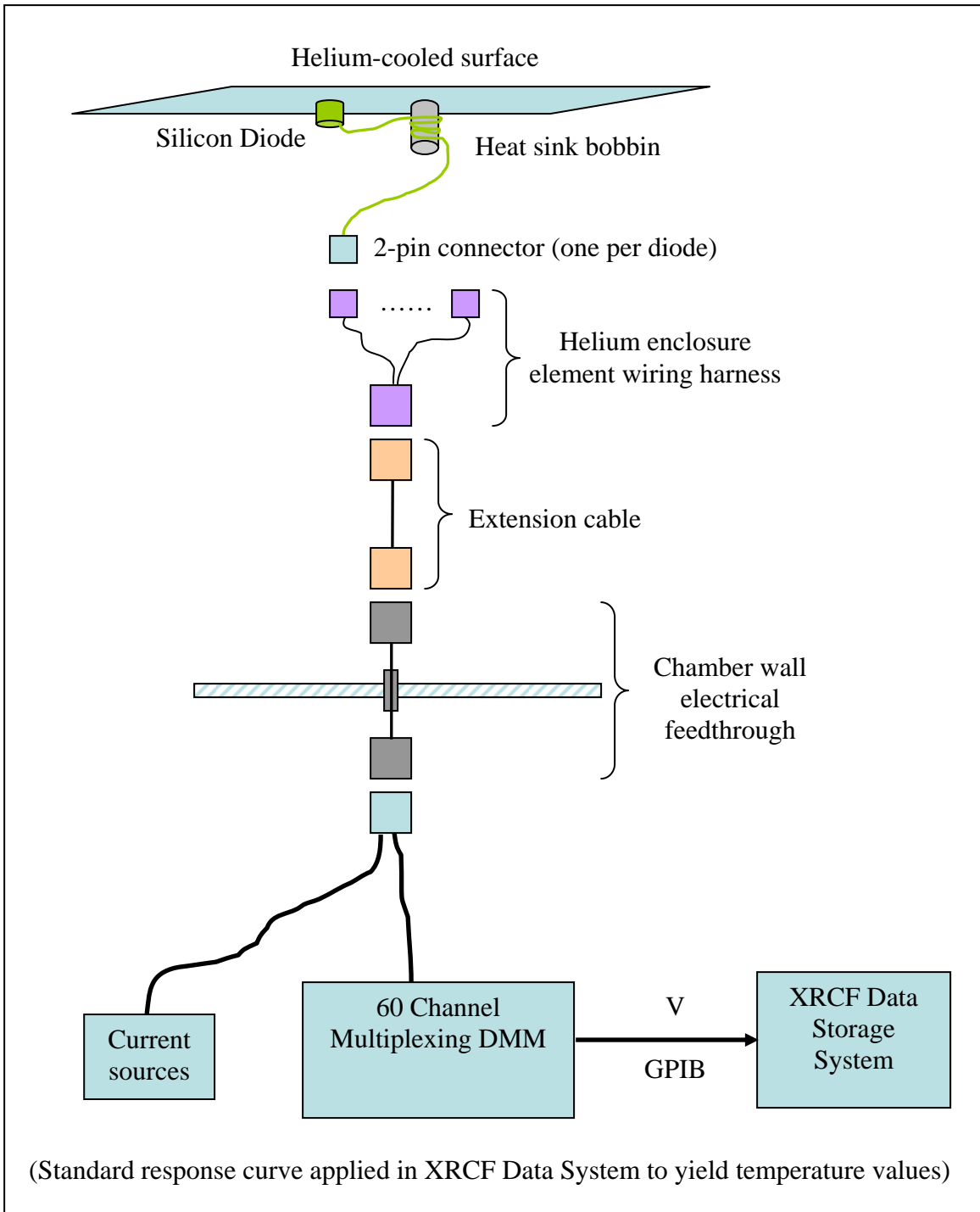

Figure 2: Facility Environment DAQ

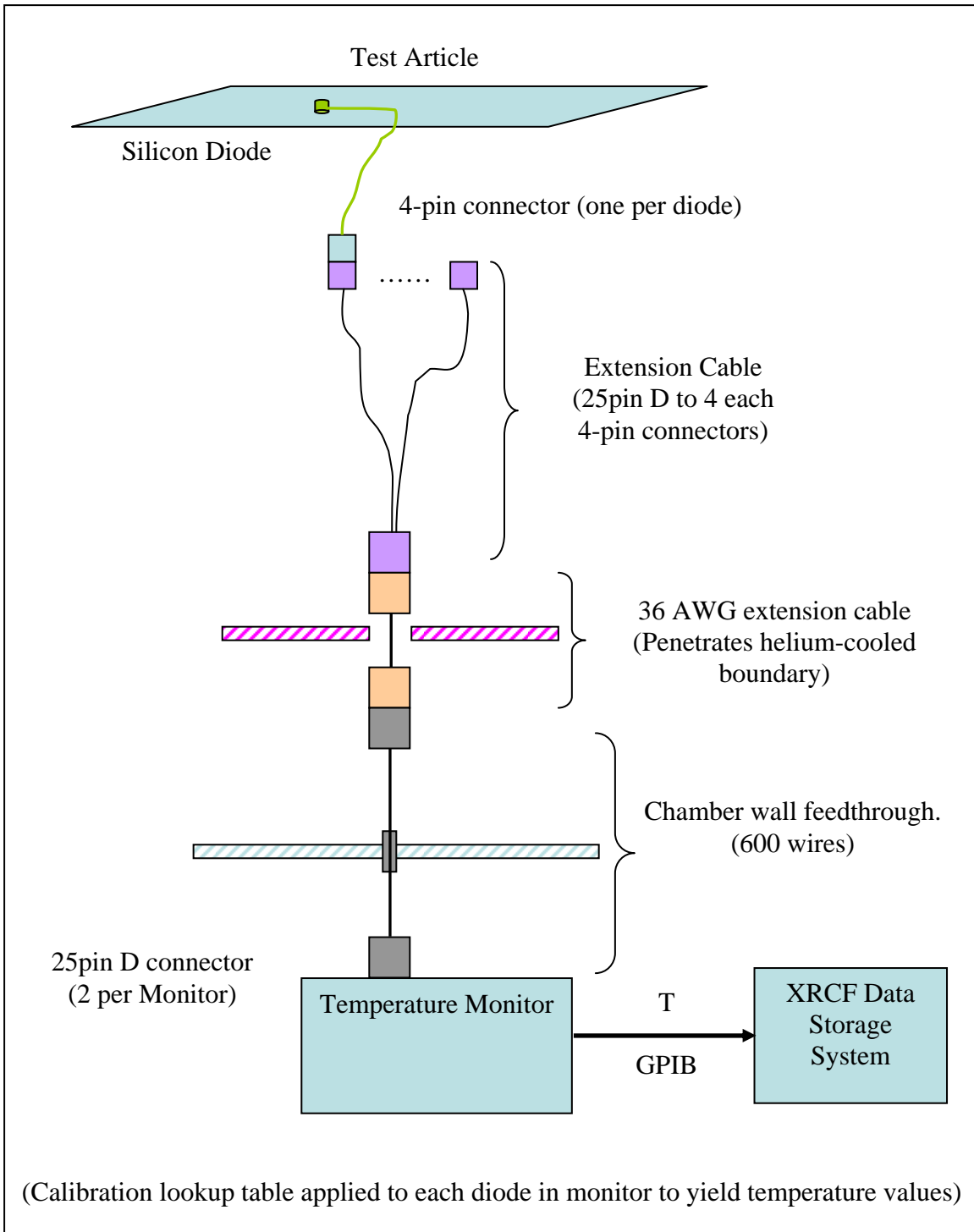

Figure 3: Test Article DAQ



THERMAL (SILICON DIODE) DATA ACQUISITION SYSTEMS

25th Space Simulation Conference
Annapolis, MD
October 23, 2008

jeff.kegley@nasa.gov
256.544.2291

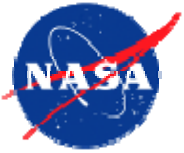

Chamber Overview

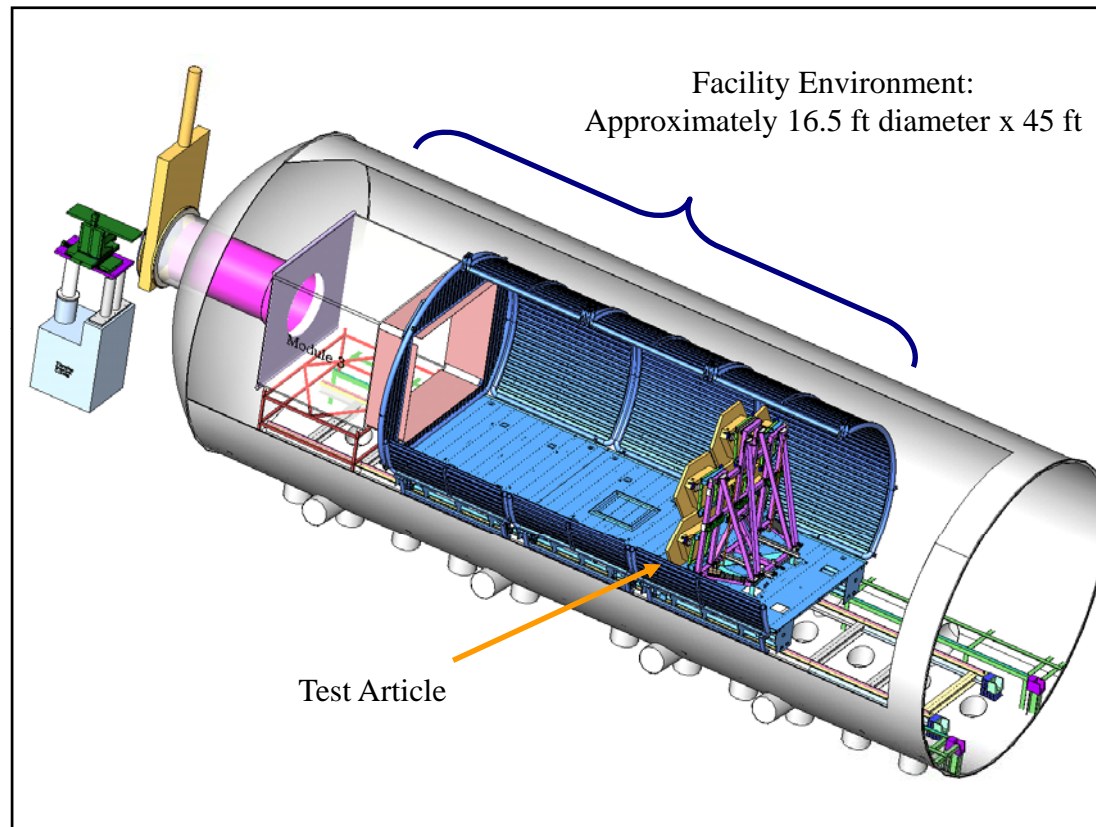
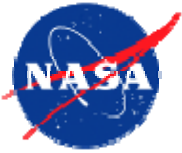

Figure 1: XRCF Helium Cooled Enclosure



Environment Diode Schematic

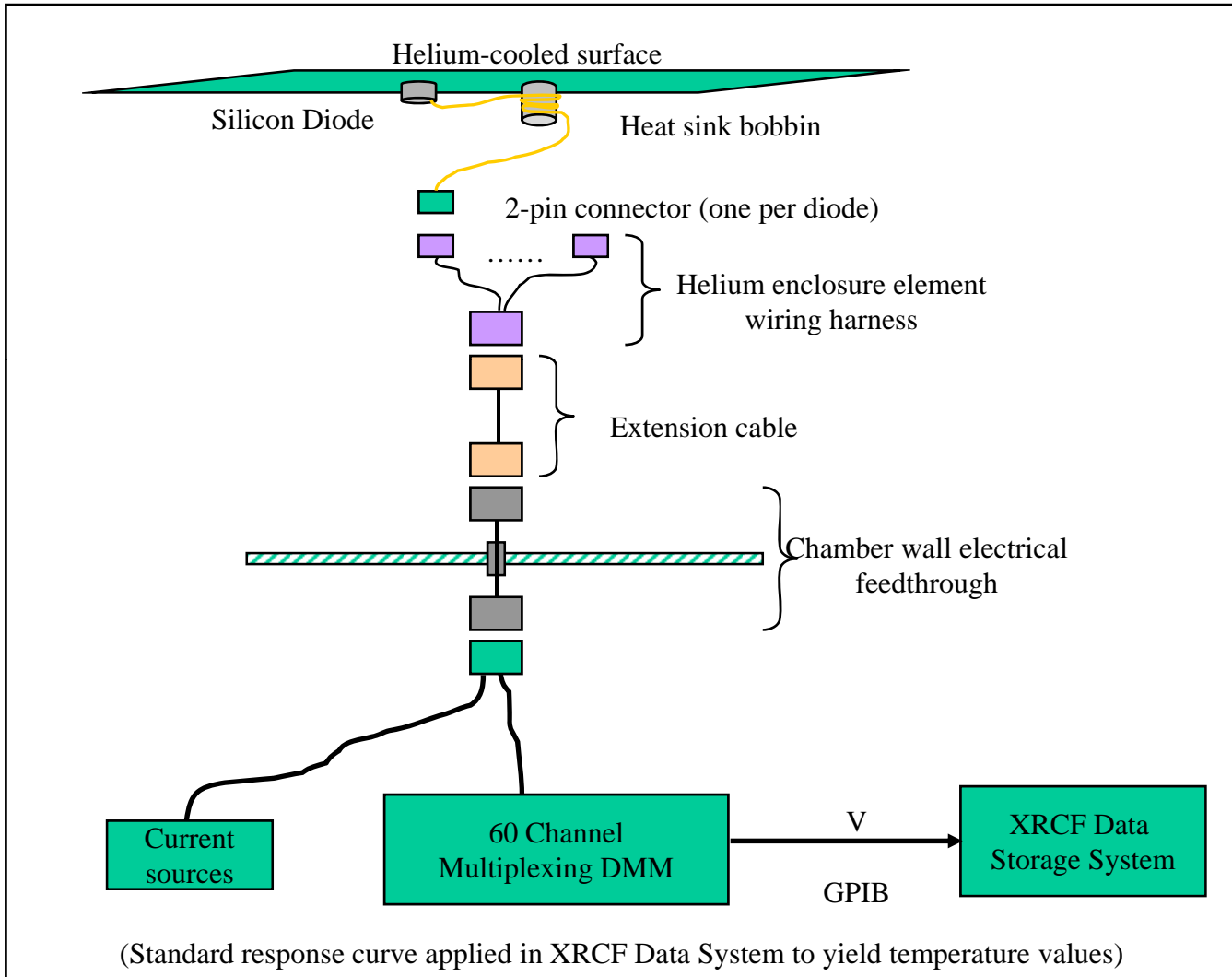
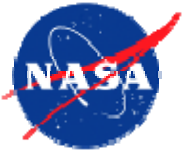

Figure 2: Facility Environment DAQ



Test Article Diode Schematic

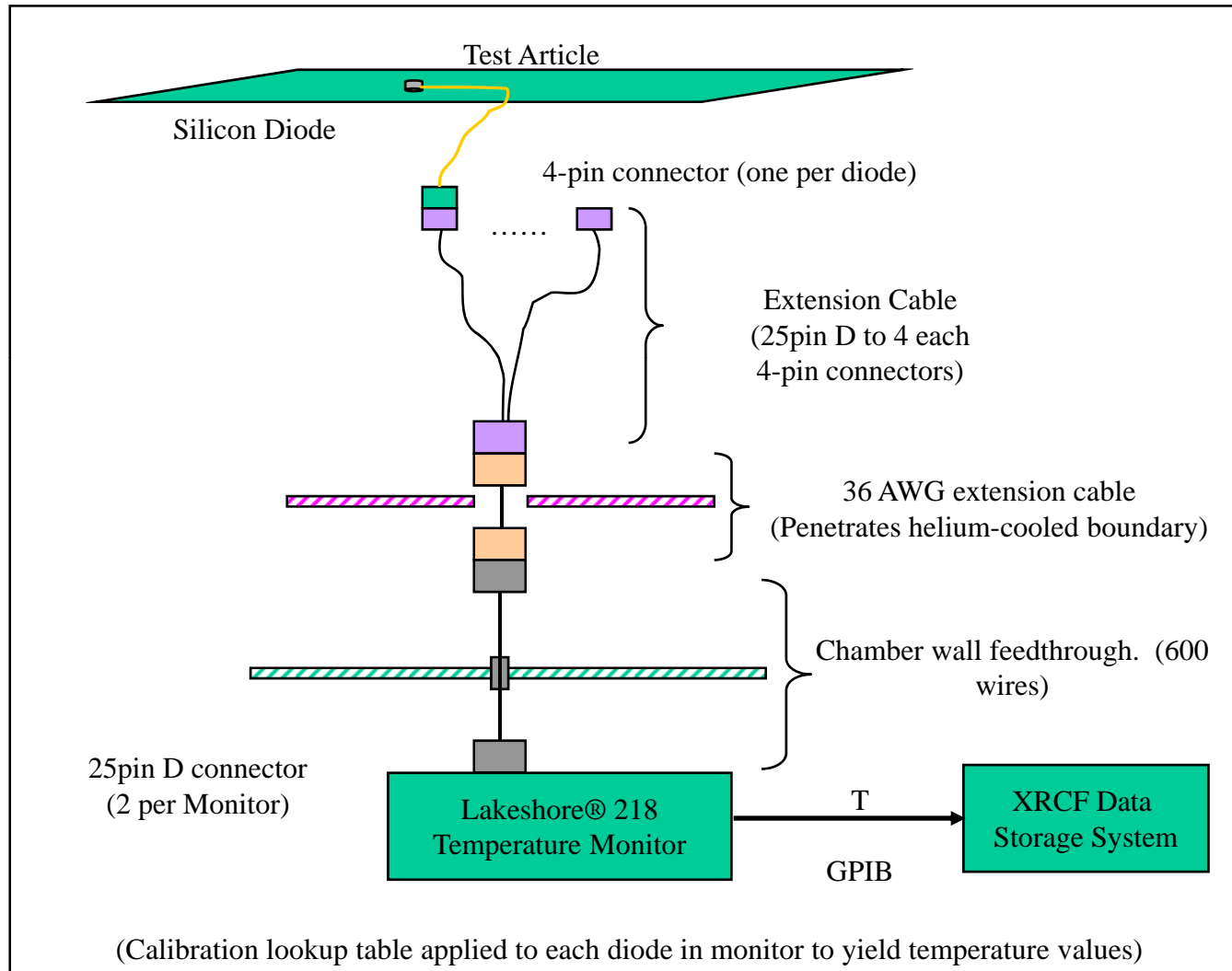
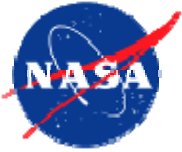

Figure 3: Test Article DAQ



THERMAL (SILICON DIODE) DATA ACQUISITION SYSTEMS

25th Space Simulation Conference
Annapolis, MD
October 23, 2008

jeff.kegley@nasa.gov
256.544.2291