

NASA/TM-2009-215569  
NESC-RP-08-31/08-00451



# Crew Exploration Vehicle (CEV) Avionics Integration Laboratory (CAIL) Independent Analysis

*Mitchell L. Davis/NESC, Michael L. Aguilar/NESC  
NASA Goddard Space Flight Center, Greenbelt, Maryland*

*Victor D. Mora  
Jet Propulsion Laboratory, Pasadena, California*

*Victoria A. Regenie/NESC  
NASA Dryden Flight Research Center, Edwards, California*

*William F. Ritz  
Jet Propulsion Laboratory, Pasadena, California*

## The NASA STI Program. . . in Profile

Since its founding, NASA has been dedicated to the advancement of aeronautics and space science. The NASA Scientific and Technical Information (STI) Program Office plays a key part in helping NASA maintain this important role.

The NASA STI Program Office is operated by Langley Research Center, the lead center for NASA's scientific and technical information. The NASA STI Program Office provides access to the NASA STI Database, the largest collection of aeronautical and space science STI in the world. The Program Office is also NASA's institutional mechanism for disseminating the results of its research and development activities. These results are published by NASA in the NASA STI Report Series, which includes the following report types:

- **TECHNICAL PUBLICATION.** Reports of completed research or a major significant phase of research that present the results of NASA programs and include extensive data or theoretical analysis. Includes compilations of significant scientific and technical data and information deemed to be of continuing reference value. NASA counterpart of peer-reviewed formal professional papers, but having less stringent limitations on manuscript length and extent of graphic presentations.
- **TECHNICAL MEMORANDUM.** Scientific and technical findings that are preliminary or of specialized interest, e.g., quick release reports, working papers, and bibliographies that contain minimal annotation. Does not contain extensive analysis.
- **CONTRACTOR REPORT.** Scientific and technical findings by NASA-sponsored contractors and grantees.

- **CONFERENCE PUBLICATION.** Collected papers from scientific and technical conferences, symposia, seminars, or other meetings sponsored or co-sponsored by NASA.
- **SPECIAL PUBLICATION.** Scientific, technical, or historical information from NASA programs, projects, and missions, often concerned with subjects having substantial public interest.
- **TECHNICAL TRANSLATION.** English-language translations of foreign scientific and technical material pertinent to NASA's mission.

Specialized services that complement the STI Program Office's diverse offerings include creating custom thesauri, building customized databases, organizing and publishing research results ... even providing videos.

For more information about the NASA STI Program Office, see the following:

- Access the NASA STI Program Home Page at <http://www.sti.nasa.gov>
- E-mail your question via the Internet to [help@sti.nasa.gov](mailto:help@sti.nasa.gov)
- Fax your question to the NASA STI Help Desk at (443) 757-5803
- Phone the NASA STI Help Desk at (443) 757-5802
- Write to:  
NASA STI Help Desk  
NASA Center for AeroSpace Information  
7115 Standard Drive  
Hanover, MD 21076-1320

NASA/TM-2009-215569  
NESC-RP-08-31/08-00451



# Crew Exploration Vehicle (CEV) Avionics Integration Laboratory (CAIL) Independent Analysis

*Mitchell L. Davis/NESC, Michael L. Aguilar/NESC  
NASA Goddard Space Flight Center, Greenbelt, Maryland*

*Victor D. Mora  
Jet Propulsion Laboratory, Pasadena, California*

*Victoria A. Regenie/NESC  
NASA Dryden Flight Research Center, Edwards, California*

*William F. Ritz  
Jet Propulsion Laboratory, Pasadena, California*

NASA Engineering and Safety Center  
Langley Research Center  
Hampton, Virginia 23681-2199

February 2009

The use of trademarks or names of manufacturers in the report is for accurate reporting and does not constitute an official endorsement, either expressed or implied, of such products or manufacturers by the National Aeronautics and Space Administration.

Available from:  
NASA Center for AeroSpace Information  
7115 Standard Drive  
Hanover, MD 21076-1320  
(443) 757-5802

	<b>NASA Engineering and Safety Center Report</b>	Document #: <b>RP-08-31</b>	Version: <b>1.0</b>
Title: <b>Crew Exploration Vehicle (CEV) Avionics Integration Laboratory (CAIL) Independent Analysis</b>			Page #: 1 of 39

# **Crew Exploration Vehicle (CEV) Avionics Integration Laboratory (CAIL) Independent Analysis**

**May 1, 2008**



**NASA Engineering and Safety Center  
Report**

Document #:  
**RP-08-31**

Version:  
**1.0**

Title:

**Crew Exploration Vehicle (CEV) Avionics Integration  
Laboratory (CAIL) Independent Analysis**

Page #:  
2 of 39

**Approval and Document Revision History**

Approved: _____	Original signature on file NESC Director	5/6/08 Date
-----------------	---	----------------

<b>Version</b>	<b>Description of Revision</b>	<b>Author</b>	<b>Effective Date</b>
	Initial Release	NASA Technical Fellow, Avionics, GSCF	05-01-08

	<b>NASA Engineering and Safety Center Report</b>	Document #: <b>RP-08-31</b>	Version: <b>1.0</b>
Title: <b>Crew Exploration Vehicle (CEV) Avionics Integration Laboratory (CAIL) Independent Analysis</b>			Page #: 3 of 39

## Table of Contents

### Volume I: Technical Report

<b>1.0</b>	<b>Authorization and Notification</b> .....	<b>5</b>
<b>2.0</b>	<b>Signature Page</b> .....	<b>6</b>
<b>3.0</b>	<b>Team List</b> .....	<b>7</b>
<b>4.0</b>	<b>Executive Summary</b> .....	<b>8</b>
<b>5.0</b>	<b>Task Overview</b> .....	<b>10</b>
5.1	Integration and Test Process.....	12
5.2	Flat-Sat Approach.....	15
5.2.1	Flat-Sat System Fidelity.....	16
5.2.2	System Software Development Major Attributes of Integration Labs.....	18
5.2.3	Software Development Parallel Analysis, Evaluation, Integration, and Test.....	18
5.2.4	Flat-Sat Summary.....	19
5.3	SAIL Approach.....	19
5.3.1	SAIL Summary.....	28
5.4	CAIL Concept.....	28
5.4.1	CAIL Summary.....	30
5.5	Software Test Beds.....	31
5.5.1	An Example of Distributed Software Development Analysis, Evaluation, Integration, and Test.....	31
5.6	Comparison Summary of SAIL, CAIL, and Flat-Sat.....	32
<b>6.0</b>	<b>Comments from NESC Preliminary Briefing (March 17, 2008)</b> .....	<b>33</b>
<b>7.0</b>	<b>Findings, Observations, and Recommendations</b> .....	<b>35</b>
7.1	Findings.....	35
7.2	Observations.....	35
7.3	Recommendation.....	36
<b>8.0</b>	<b>Definition of Terms</b> .....	<b>36</b>
<b>9.0</b>	<b>List of Acronyms</b> .....	<b>37</b>
<b>10.0</b>	<b>References</b> .....	<b>38</b>

#### List of Figures

Figure 5.0-1.	Lunar Reconnaissance Orbiter Breadboard (left), and Lunar Reconnaissance Orbiter Spacecraft (right).....	10
---------------	---	----



<b>NASA Engineering and Safety Center Report</b>	Document #: <b>RP-08-31</b>	Version: <b>1.0</b>
Title: <b>Crew Exploration Vehicle (CEV) Avionics Integration Laboratory (CAIL) Independent Analysis</b>		Page #: 4 of 39

Figure 5.0-2. Solar Dynamics Observatory Flat-Sat Engineering Test Units (left) and Ground Controller (right)..... 11

Figure 5.0-3. Tropical Rainfall Measuring Mission Flat-Sat in Operational Support..... 11

Figure 5.0-4. Hubble Space Telescope VEST in Clean Room..... 12

Figure 5.1-1. Flight System Development Process ..... 13

Figure 5.1-2. Comparison of the Flat-Sat Approach to the SAIL/CAIL Approach ..... 14

Figure 5.2-1. Flat-Sat Approach Phasing Relative to the Flight System..... 16

Figure 5.2-2. Notional Diagram of Flat-Sat range of Fidelity ..... 17

Figure 5.3-1. SAIL Shuttle Test Station Vehicle Layout ..... 21

Figure 5.3-2. SAIL Mission Capability ..... 22

Figure 5.3-3. Shuttle Test Station, including the SAIL Flight System..... 24

Figure 5.3-4. Middeck of the Forward Avionics Bays ..... 24

Figure 5.3-5. Aft Avionics Bays with Two SSME Controllers..... 25

Figure 5.3-6. Launch Processing System ..... 25

Figure 5.3-7. Test Operations Center ..... 26

Figure 5.3-8. Digital Strip Chart Recorders..... 26

Figure 5.3-9. SAIL Verification Process Flow ..... 27

Figure 5.4-1. CEV Development Flow..... 29



	<b>NASA Engineering and Safety Center Report</b>	Document #: <b>RP-08-31</b>	Version: <b>1.0</b>
Title: <b>Crew Exploration Vehicle (CEV) Avionics Integration Laboratory (CAIL) Independent Analysis</b>			Page #: 5 of 39

## Volume I: Technical Report

### 1.0 Authorization and Notification

Mr. Doug Cooke, NASA Deputy Associate Administrator for the Exploration Systems Mission Directorate (ESMD) at NASA Headquarters, requested a Crew Exploration Vehicle (CEV) Avionics Integrated Lab (CAIL) Independent Analysis to compare the strategic differences, risks and benefits between the current CAIL approaches to alternative NASA approaches. The NESC team worked independent of the Constellation Program (CxP) to evaluate both flight hardware and software development.

-The NESC team started their comparison with the Shuttle Avionics Integration Laboratory (SAIL) and robotic mission “Flat-Sat” approach.

An NESC out-of-board activity was approved February 8, 2008 and Mr. Mitchell L. Davis, NASA Technical Fellow for Avionics, was chosen to lead this assessment. A stakeholder outbrief was presented to NESC Review Board (NRB) on March 13, 2008. A formal stakeholder outbrief was presented to Dr. Richard Gilbrech, Associate Administrator for the Exploration Systems Mission Directorate (ESMD) at NASA Headquarters, and guests at NASA Headquarters on March 18, 2008. The final NESC CAIL report was presented to the NRB on May 1, 2008.

The key stakeholder for this assessment is Mr. Doug Cooke. The project’s point of contact is Mr. Aaron Van Baalen, Avionics and Software Test & Verification (T&V) Lead, Orion Project Office.

	<b>NASA Engineering and Safety Center Report</b>	Document #: <b>RP-08-31</b>	Version: <b>1.0</b>
Title: <b>Crew Exploration Vehicle (CEV) Avionics Integration Laboratory (CAIL) Independent Analysis</b>		Page #: 6 of 39	

## 2.0 Signature Page

### Assessment Team Members

Mr. Mitchell L. Davis	Date	Mr. Michael L. Aguilar	Date
Mr. Victor D. Mora	Date	Mr. William F. Ritz	Date
Ms. Victoria A. Regenie	Date		

	<b>NASA Engineering and Safety Center Report</b>	Document #: <b>RP-08-31</b>	Version: <b>1.0</b>
Title: <b>Crew Exploration Vehicle (CEV) Avionics Integration Laboratory (CAIL) Independent Analysis</b>			Page #: 7 of 39

### 3.0 Team List

Name	Discipline	Organization/Location
<b>Core Team</b>		
Mitch Davis	Lead, Technical Fellow Avionics	GSFC
Michael Aguilar	Co-Lead, Technical Fellow Software	GSFC
Victor Mora	Deputy Integration and Test Manager for Advanced Mirror Development (AMD) Project	JPL
William Ritz	NASA SAIL Manager	JSC (Retired)
Victoria Regenie	NESC Systems Engineer	DFRC
<b>Support</b>		
Angela Hinton	Project Coordinator	ATK, LaRC
Erin Moran	Technical Writer	ATK, LaRC

	<b>NASA Engineering and Safety Center Report</b>	Document #: <b>RP-08-31</b>	Version: <b>1.0</b>
Title: <b>Crew Exploration Vehicle (CEV) Avionics Integration Laboratory (CAIL) Independent Analysis</b>			Page #: 8 of 39

## 4.0 Executive Summary

Two approaches were compared to the Crew Exploration Vehicle (CEV) Avionics Integration Laboratory (CAIL) approach: the Flat-Sat and Shuttle Avionics Integration Laboratory (SAIL). The Flat-Sat and CAIL/SAIL approaches are two different tools designed to mitigate different risks. Flat-Sat approach is designed to develop a mission concept into a flight avionics system and associated ground controller. The SAIL approach is designed to aid in the flight readiness verification of the flight avionics system. The approaches are complimentary in addressing both the system development risks and mission verification risks.

The CAIL concept is modeled after the SAIL approach with a number of notable differences. These include: For the Orion Project, a coordinated, end-to-end box to system level development and verification process was not evident in the information provided. For the CAIL concept, a coordinated, end-to-end box to system level development and verification process was not evident in the information provided. The CAIL concept assumes the flight subsystems will be matured for the system level verification prior integration into the CAIL. It was not apparent to the NESC team that there was a documented plan to assure unit/sub-system maturity prior to installation into the CAIL. Both the CAIL and the Lockheed-Martin (LM) operated Exploration Development Laboratory (EDL) documents did not reference any intentional effort to provide an engineering team knowledge transfer from the CAIL integration and verification team to the ground operations and mission operations teams. The NESC team noted that, based on their experience, successful projects are keenly aware of their tools' abilities and limitations and can quickly adjust to the dynamically changing risk priority and hardware/software configurations during the development phase. Coordination of the verification process is essential to minimize the risk of missing key issues and to be prepared for schedule deviations.

The Flat-Sat approach starts early in the development and is designed to mature into an accurate representation of the flight system. It then transitions to supporting flight software development and mission operations. The SAIL approach is a high fidelity engineering replication of the flight article designed to verify integrated system performance, capture system discrepancies from mission to mission, and aid in reducing schedule pressures on the flight article.

The SAIL approach is to use flight qualifiable or qualified hardware in the flight systems. However, depending on unique test requirements, it may use component simulators or engineering test units (ETUs).

The following NESC team findings were identified:

- A coordinated, end-to-end, box to system level development and verification process was not evident for the proposed CAIL concept.

	<b>NASA Engineering and Safety Center Report</b>	Document #: <b>RP-08-31</b>	Version: <b>1.0</b>
Title: <b>Crew Exploration Vehicle (CEV) Avionics Integration Laboratory (CAIL) Independent Analysis</b>		Page #: 9 of 39	

- The CAIL assumption is that the flight subsystems will be matured for the *system level* verification.
- The Flat-Sat and SAIL approaches are two different tools designed to mitigate different risks.

The following NESC team recommendation was provided:

- Define, document, and manage a detailed interface between the design and development (EDL and other integration labs) to the verification laboratory (CAIL).

The Orion Project Office is actively working this recommendation.

	<b>NASA Engineering and Safety Center Report</b>	Document #: <b>RP-08-31</b>	Version: <b>1.0</b>
Title: <b>Crew Exploration Vehicle (CEV) Avionics Integration Laboratory (CAIL) Independent Analysis</b>			Page #: 10 of 39

## 5.0 Task Overview

To accomplish this quick turnaround assessment (3-week timeframe), the approach taken involved a combination of interviews of subject matter experts (SMEs) associated with Flat-Sat and SAIL operations and a review of available documentation associated with the proposed Orion CAIL concept. Section 10.0 provides the references the NESC team reviewed for this assessment.

The SME interview process started with the Goddard Space Flight Center (GSFC) Integration and Test (I&T) Branch Head was interviewed for a detailed summary of the Flat-Sat approach. This summary was shared with the NESC team with additional inputs from: Victor Mora, Jet Propulsion Laboratory (JPL); the NASA Technical Fellows for Avionics and Software; and Bill Ritz, retired SAIL Manager. Mr. Ritz, retired SAIL Manager, provided the team with a detailed overview of the SAIL operation and development history. Aaron Van Baalen, Avionics and Software T&V Lead, provided a detailed description of the planned CAIL operations approach.

On March 3, 2008, the Johnson Space Center (JSC) Engineering Directorate, Avionic Systems Division, senior leaders and CAIL team leaders met at GSFC for a Flat-Sat discussion and tour of the Lunar Reconnaissance Orbiter (LRO) (Figure 5.0-1), Solar Dynamics Observatory (SDO) (Figure 5.0-2), Tropical Rainfall Measuring Mission (TRMM) (Figure 5.0-3), and Wilkinson Microwave Anisotropy Probe (WMAP) Flat-Sat laboratories. Additionally, the Hubble Space Telescope's Vehicle Electrical System Test (VEST), which serves a similar purpose as the SAIL/CAIL (Figure 5.0-4), was also visited. At the conclusion of this visit, good understanding on the similarities and differences of the various approaches among the NESC team, JSC Engineering Directorate senior leaders, and the CAIL team leaders was achieved.

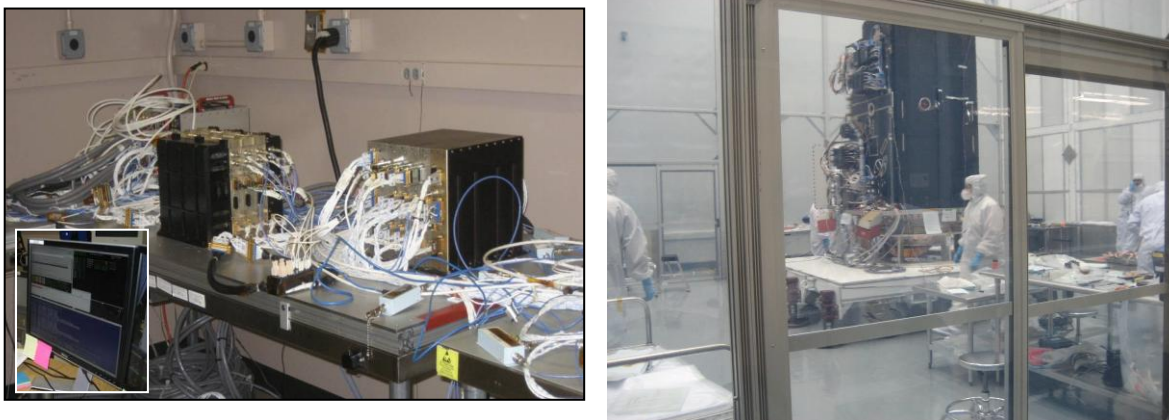

**Figure 5.0-1. Lunar Reconnaissance Orbiter Breadboard (left), and Lunar Reconnaissance Orbiter Spacecraft (right)**





**NASA Engineering and Safety Center  
Report**

Document #:  
**RP-08-31**

Version:  
**1.0**

Title:

**Crew Exploration Vehicle (CEV) Avionics Integration  
Laboratory (CAIL) Independent Analysis**

Page #:  
11 of 39

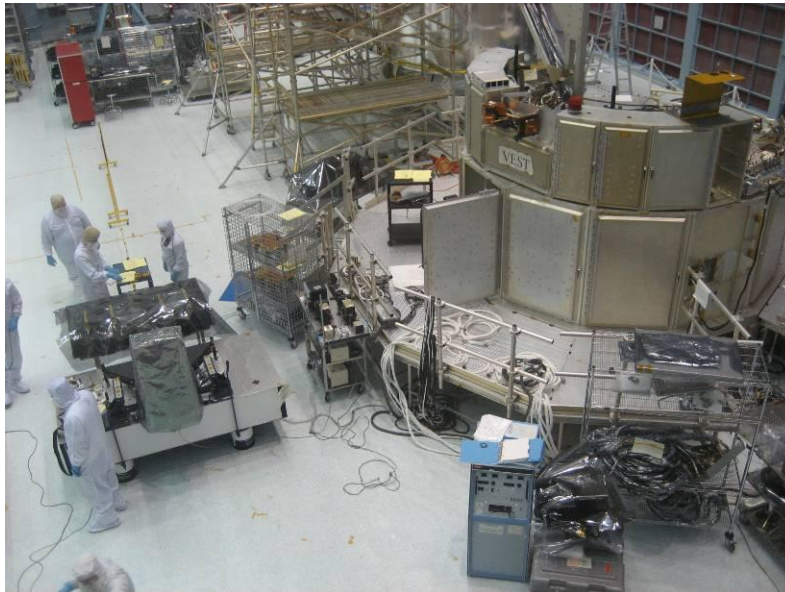

**Figure 5.0-2. Solar Dynamics Observatory Flat-Sat Engineering Test Units (left) and  
Ground Controller (right)**



**Figure 5.0-3. Tropical Rainfall Measuring Mission Flat-Sat in Operational Support**

	<b>NASA Engineering and Safety Center Report</b>	Document #: <b>RP-08-31</b>	Version: <b>1.0</b>
Title: <b>Crew Exploration Vehicle (CEV) Avionics Integration Laboratory (CAIL) Independent Analysis</b>			Page #: 12 of 39



**Figure 5.0-4. Hubble Space Telescope VEST in Clean Room**

## 5.1 Integration and Test Process

For this report, I&T is the process that matures a design concept and develops and integrates the flight hardware with ground controller systems into a fully integrated operational system. The NESC team found that some terms used to describe the I&T process caused confusion during interchanges due to location specific definitions. Therefore, for this assessment, the NESC team clarified the I&T definition to enable focusing on the general process and not the specific different details.

- “Development” refers to the process of functional testing, interface testing, open-loop testing, and close-loop testing necessary to mature a concept into an operational system.
- “Verification” refers to the formal process of demonstrating a design is flight ready and is assumed to be interchangeable in the general sense with the terms verification, validation and certification.
- “Flight Avionics System” refers to all electrical/electronic systems that will fly on the vehicle.
- “Ground Controller” refers to the ground electrical/electronic systems, tools, and procedures that enable the development and operation of the Flight Avionics System.

During the development process, different combinations of electrical/electronic systems and ground systems replicate various flight configurations enabling the design evolution from



	<b>NASA Engineering and Safety Center Report</b>	Document #: <b>RP-08-31</b>	Version: <b>1.0</b>
Title: <b>Crew Exploration Vehicle (CEV) Avionics Integration Laboratory (CAIL) Independent Analysis</b>			Page #: 13 of 39

concept into a flight-ready system. There is no standard and fixed tool set; rather the tools depend directly on the project's risks and mitigation plan. Some examples of these tools include software test beds, computer development unit, and simulators. The NESC team noted that, based on their experience, the successful projects are the ones who are keenly aware of their tools' abilities and limitations and can quickly adjust to the dynamically changing risk priority and hardware/software configurations of the development phase.

Early in the development cycle of a space flight design, high level requirements are parceled out to lower level subsystems, as shown in Figure 5.1-1. The requirements are then translated into functions that will be implemented in the specific hardware or software subsystem. Decisions are made regarding all aspects of the design, from the electrical circuit architecture to wire routing. These decisions will then define the design features. The subsystem is assembled into a system with an associated ground controller. Later in the development process, the subsystem was confirmed that the initial requirements were met and, more importantly, all other design features were documented. The requirements are the minimal set of functions that the system *must do* where the design features are all functions the system *can do*.

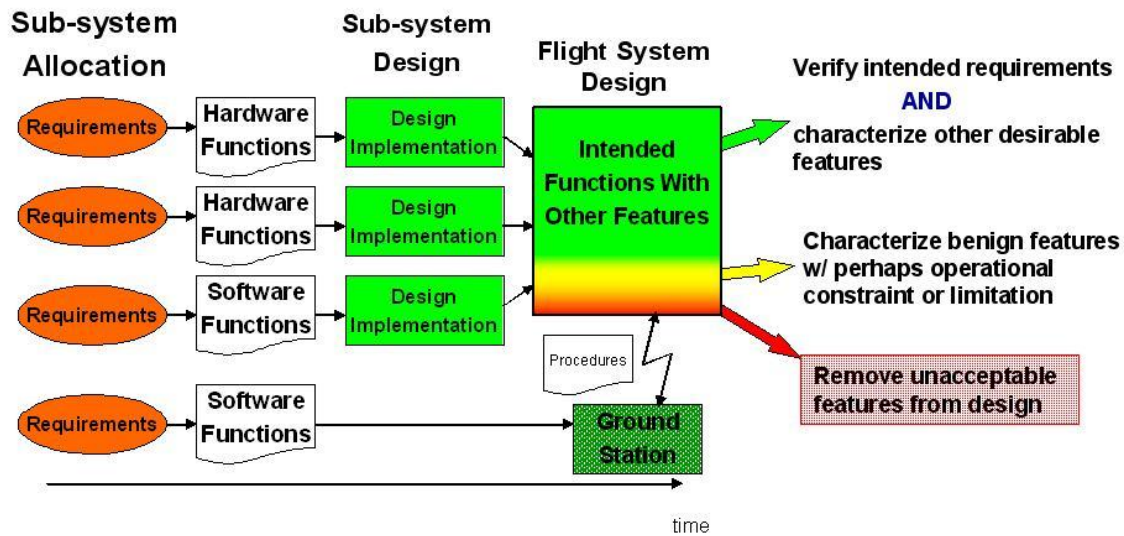

**Figure 5.1-1. Flight System Development Process**

A large portion of these design features are desirable and aid in meeting the requirement. For example, the power interface and the command interface to a computer which implements the control requirement are necessary design features (e.g. results of the implementation). Some of these design features are benign and may not be desirable, but are not at a risk level that would dictate removal from the design; rather they lead to a limitation or operational constraint. For

	<b>NASA Engineering and Safety Center Report</b>	Document #: <b>RP-08-31</b>	Version: <b>1.0</b>
	Title: <b>Crew Exploration Vehicle (CEV) Avionics Integration Laboratory (CAIL) Independent Analysis</b>		Page #: 14 of 39

example, a condition in which simultaneously executing commands subsystem-A ON and subsystem-B ON under worst case conditions will trip the circuit breaker. Since the ON commands are an infrequent operation, one is willing to accept an operational constraint of 200 milliseconds between commands. The remaining design features are those that are undesirable and can lead to a premature anomaly or system failure. Once identified, the undesired feature is removed from the design. The undesirable features are discovered throughout the development phase by identifying a discrepancy between a predicted or expected subsystem response and the actual hardware/software response.

The Flat-Sat approach is commonly used in the robotic spacecraft development where a single or limited number spacecraft or set of spacecraft are built. For the development of the single spacecraft, the formal system verification must occur on the flight unit to contain the risk to an acceptable level. The Flat-Sat serves three general purposes which align to the different phases of the development: I&T development (primary purpose), the flight software development (secondary purpose), and the flight operations support and maintenance (tertiary purpose). The Flat-Sat approach is optimized for development where the fidelity and configuration control is moderated to enable rapid design evolution from an initial concept to a flight ready system. For the single or set of missions, the formal verification process occurs on the flight unit and therefore there is less need for flight readiness verification on a high fidelity copy. Figure 5.1-2 compares the Flat-Sat approach to the SAIL/CAIL approach.

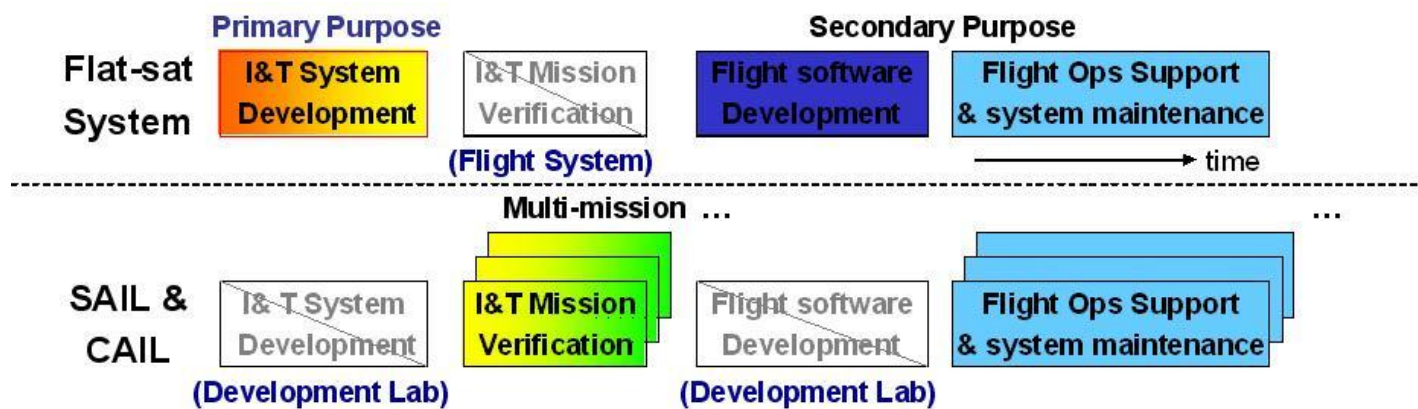

**Figure 5.1-2. Comparison of the Flat-Sat Approach to the SAIL/CAIL Approach**

For the SAIL approach, high fidelity and rigorous configuration control enables flight avionics verification with high degree of confidence for the first mission and subsequent missions. The SAIL approach is optimized to identify subtle discrepancies in the design by a high fidelity replication of the flight avionics system. For multi-missions, the SAIL approach provides the

	<b>NASA Engineering and Safety Center Report</b>	Document #: <b>RP-08-31</b>	Version: <b>1.0</b>
Title: <b>Crew Exploration Vehicle (CEV) Avionics Integration Laboratory (CAIL) Independent Analysis</b>		Page #: 15 of 39	

tool for the formal flight readiness verification prior to final installation on the vehicle and allows identification and resolution of system level discrepancies from mission to mission.

## 5.2 Flat-Sat Approach

The Flat-Sat begins assembly shortly after the Preliminary Design Review (PDR). It is an assembly of key subsystem Engineering Test Units (ETUs), simulators, ground controller and a flight-like harness. A ground controlling system is developed in conjunction with the flight-like avionics system. Shortly after the Critical Design Review (CDR), the amount of testing on the Flat-Sat accelerates as the spacecraft matures. When a major subsystems arrives, extensive interface and functional tests are completed which result in discovering discrepancies in the requirements or design that lead to improvements in the flight design and increased accuracy of the Flat-Sat's simulation. Discovering these discrepancies in this early phase allows for changes to be incorporated into the flight design prior to delivery. Since the design engineers and the ground operations team are both working concurrently on the Flat-Sat, there is beneficial knowledge transferred between the teams. The Flat-Sat approach also enables the concurrent development of all integration plans and procedures, the ground controller command files, and the telemetry files data base.

The GSFC practice is to not place a flight unit into the Flat-Sat mainly due to the lack of historical pedigree of the associated flight-like avionics. However, JPL does not have this practice. It is common to place a Flat-Sat ETU into the flight subsystem as a place-holder while the flight unit is elsewhere. Around the time the first Comprehensive Performance Test is completed on the flight system, the Flat-Sat would primarily be supporting flight software development. When a discrepancy is discovered that results in a hardware change, the corrective action is demonstrated on the Flat-Sat before implementation on the flight system. Upon launch, the Flat-Sat operation is transferred to the flight operations team for flight operational support and software maintenance. Figure 5.2-1 illustrates this progression. For large out-of-house spacecraft like Earth Observing System (EOS)-Aqua and EOS-Aura, a Flat-Sat is a contractor-owned system, with a separate, nearly identical Flat-Sat system delivered for operational support. See Figure 5.2-1.

	<b>NASA Engineering and Safety Center Report</b>	Document #: <b>RP-08-31</b>	Version: <b>1.0</b>
	Title: <b>Crew Exploration Vehicle (CEV) Avionics Integration Laboratory (CAIL) Independent Analysis</b>		Page #: 16 of 39

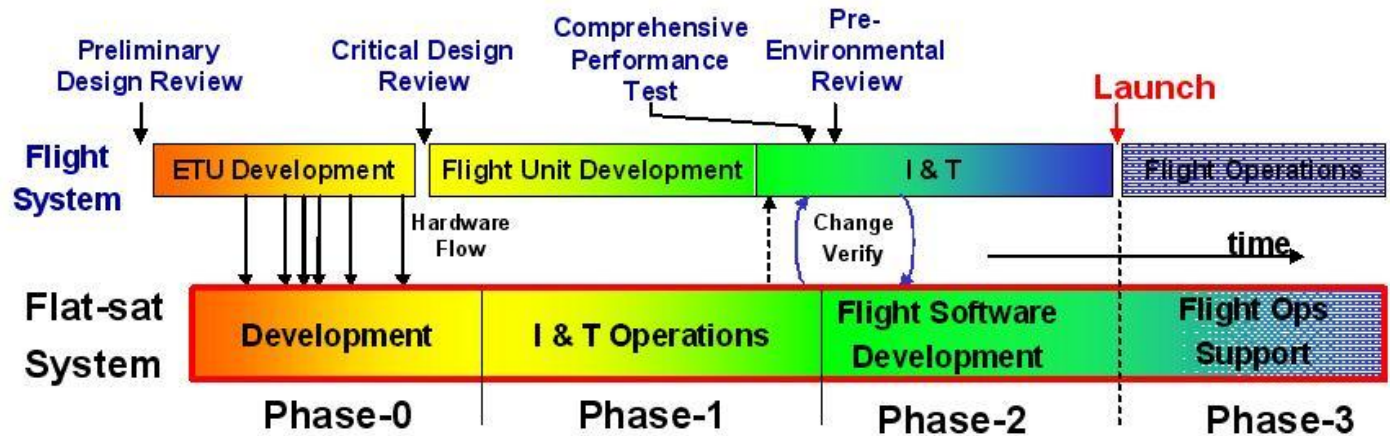



Figure 5.2-1. Flat-Sat Approach Phasing Relative to the Flight System

### 5.2.1 Flat-Sat System Fidelity

The Flat-Sat hardware is comprised of ETUs that are modified to be configurationally identical with the current flight design. Additionally, fidelity of the simulators increase as discrepancies are discovered and mitigated by design modifications. The fidelity of the wire will vary depending on the potential risk. High speed complex interfaces require duplication of the flight design and length. Experience has shown that a lower fidelity power harness is an acceptable risk and thus the exact flight length is not typically replicated. Figure 5.2-2 describes, in a notational sense, variations in fidelity of the Flat-Sat over time. The discrepancies in the ordinate axis are defined as system responses that are different from expected responses. As mentioned earlier, the discrepancies are a result of design features which can be beneficial, benign or undesirable. It is the benign design features which lead to limitation or operational constraints and the undesirable design features which are most critical to identify. These hidden discrepancies are discovered by operational time and testing of the Flat-Sat system. Note that a finite or limited time from initial concept to launch, which is what creates the acceptable risk level.



	<b>NASA Engineering and Safety Center Report</b>	Document #: <b>RP-08-31</b>	Version: <b>1.0</b>
Title: <b>Crew Exploration Vehicle (CEV) Avionics Integration Laboratory (CAIL) Independent Analysis</b>			Page #: <b>17 of 39</b>

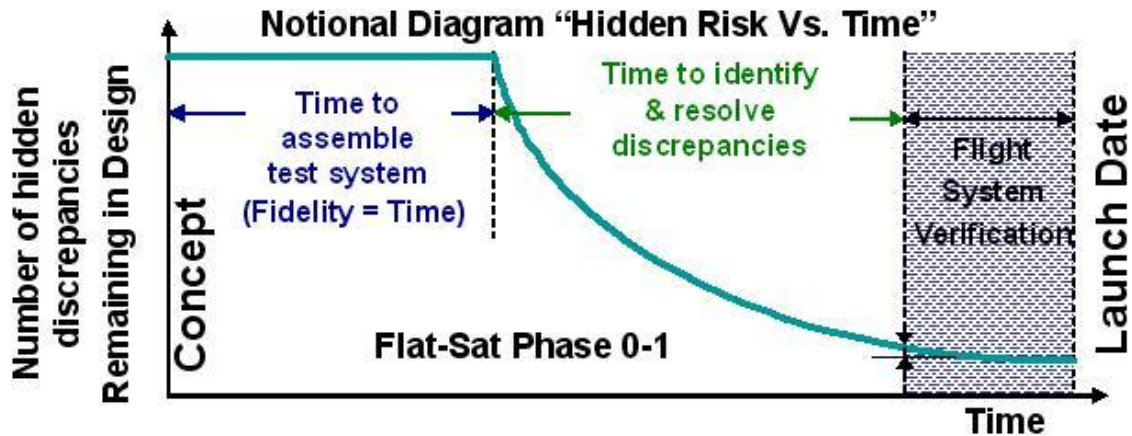



Figure 5.2-2. Notional Diagram of Flat-Sat range of Fidelity

The Flat-Sat approach is a risk trade bounded by two limits: insufficient fidelity and insufficient time. Both impede the ability to identify discrepancies prior to entering the flight system verification phase. In the flight system verification phase, a design change halts the verification, the hardware is corrected, and time consuming regression testing is required. Therefore, the desire is to maximize the discovery of (benign and undesirable) discrepancies prior to the verification phase. At one extreme, a Flat-Sat placed in operation too quickly will be of insufficient fidelity and will not adequately simulate the flight system, thus the rate of discovering discrepancies will result in the detection of an unacceptable number of discrepancies upon entering flight system verification. At the other extreme, building an exceptionally high fidelity Flat-Sat consumes a significant portion of the available time and impacts configuration management complexity. It also becomes cumbersome to reconfigure Flat-Sat systems resulting in insufficient time to identify and resolve discrepancies prior to entering the flight system verification phase. The goal is to verify all requirements on the flight system. However, those requirements that can not be verified on the flight system are verified on the lower fidelity Flat-Sat. The risk associated with a lower fidelity Flat-Sat is not directly translated to higher mission risks. The reason is most requirements are verified on the flight system, and the requirements verified on the Flat-Sat are analyzed to be at the appropriate fidelity.

Hardware and software test automation requires command and control capabilities above and beyond flight system operations. External control of test simulators and hardware is required to set initial conditions and repeat the test from these initial conditions. The capability to sense, test, and record the system response is required for automated test execution and pass-fail evaluation. Off-nominal behavior requires insertion or simulation of system faults in hardware and software, under control of the test scripts. System performance can be evaluated within the margins and limitations of the test environment fidelity. High fidelity portions of the system can be evaluated

	<b>NASA Engineering and Safety Center Report</b>	Document #: <b>RP-08-31</b>	Version: <b>1.0</b>
Title: <b>Crew Exploration Vehicle (CEV) Avionics Integration Laboratory (CAIL) Independent Analysis</b>			Page #: 18 of 39

for performance, even within an overall low-fidelity test system. Within the Flat-Sat environment, knowledge transfer of ground and mission operations is value-added to the operation, test, and development personnel. Familiarity of the mission operations equipment, procedures, and support software optimizes the quality of this knowledge transfer.

### **5.2.2 System Software Development Major Attributes of Integration Labs**

The scope and needs of the laboratory customers directly influence the test bed fidelity. Test bed customers include simulation developers, hardware and software integration and test engineers, ground operations and ground application developers, mission operators, external hardware interface engineers and system integration engineers. Scheduling the use of the system, with margin for delivery and failure analysis, determines the required number and capabilities of the test beds.

Simulation developers require access to high fidelity interfaces and models to identify the simulation accuracy and limitations of flight and ground systems. The command and control interface to these simulations need to be implemented and supported. Hardware and software integration and verification requires test suite development, command and control interface development, and access to interface signals for diagnostic purposes. Ground operations require test suite development time for environment and integration tests, test control and telemetry monitoring, and code modification procedures. External users will need access to the test bed for acceptance testing.

Sparing of hardware for the test bed and the time expected to repair the test bed should be considered. This drives maintenance personnel and maintenance scheduling requirements.

### **5.2.3 Software Development Parallel Analysis, Evaluation, Integration, and Test**

Multiple test beds of varied fidelity can be used in parallel to support user demands. An effort must be made to detail what subsystems are verified on which test environment. Software partitioning the system into subsystems, with the minimal interfaces and the minimal dependencies, reduces integration risk and effort when the subsystems are integrated. Maximizing the similarity of the test operations interfaces to the actual ground and flight operations interfaces provides an early start for ground and operations development and knowledge sharing between personnel. Even a low-fidelity test environment can provide early insight into development issues.

Software and software test bed configuration management ranges from minimal early in development to rigorous enforcement as the subsystem test beds migrate toward high-fidelity system simulations. The configuration management complexity is directly related to the number and variety of uses the test bed is required to support. Constantly switching between

	<b>NASA Engineering and Safety Center Report</b>	Document #: <b>RP-08-31</b>	Version: <b>1.0</b>
Title: <b>Crew Exploration Vehicle (CEV) Avionics Integration Laboratory (CAIL) Independent Analysis</b>		Page #: 19 of 39	

configurations to support differing users needs to be addressed in the configuration management plan.

Customers for a test bed can include parties external to a project, with conflicting schedules and priorities. Non-NASA-owned test beds can create conflicts and competition over schedule, configuration, and access to the use of the test bed.

#### 5.2.4 Flat-Sat Summary

The Flat-Sat approach regulates the hardware/software and test bed configuration control process to a level that enables rapid development of the hardware and software and, as the design matures, the fidelity and configuration control increases appropriately. Mission success is directly linked to the earliest possible testing which enables corrective feedback into flight hardware/software design prior to fabrication. The I&T process and procedures development along with Flat-Sat is another advantage, which reduces the risk of inadvertent mistakes on the flight system. Finally, developing the Flat-Sat in conjunction with the eventual ground controller allows a solid knowledge transfer between the design engineering and mission operations teams. Although the lower fidelity system will allow early discrepancies to escape, past experience has shown that overall this is the optimal approach for development and balancing cost and schedule.

### 5.3 SAIL Approach

Relative to Shuttle Avionics Integration Laboratory (SAIL) background, the Space Shuttle Task Group and technology program planning in the 1960/1970 time frame included simulation testing of an integrated electronics system to ensure compatibility of individual systems. The intent would be verification of functions involving several subsystems performing as a whole, and would lead to development of operational procedures (human/machine functional relationships, etc.) and software design and test. Completeness of the simulations would be such that they are faithful analogs of the mission/configuration under test or investigation.

The Space Shuttle Program (SSP) planning included a systems integration laboratory for subsystem development and integration, flight control, and mission verification of flight hardware/software (e.g. avionics). All Space Shuttle contractor proposals included subsystems/systems integration laboratories. The SAIL was located at the Johnson Space Center (JSC) to make use of: existing Government facilities; JSC civil service and support contractor expertise; proximity to the software development laboratory; ability to support Shuttle operational phase without being committed to a prime contractor (i.e., reduced operational costs); and better NASA insight into the development of a computer-controlled, integrated avionics system -- a novel idea in the 1971 time frame. For example, the facility and test support systems (integrated test area, test operations center, dynamics simulation, etc.) were provided by JSC.

	<b>NASA Engineering and Safety Center Report</b>	Document #: <b>RP-08-31</b>	Version: <b>1.0</b>
Title: <b>Crew Exploration Vehicle (CEV) Avionics Integration Laboratory (CAIL) Independent Analysis</b>			Page #: 20 of 39

The SAIL was a multi-center, multi-system that serviced three separate centers for vehicle I&T and operations. The Orbiter flight system and pertinent Ground Support Equipment (GSE) was provided by the Space Shuttle prime/integrating contractor. The Marshall Mated Elements System (MMES) was supplied by the Marshall Space Flight Center (MSFC) after the Approach and Landing Test (ALT), and included flight system components and pertinent GSE and test support/simulation systems. The Launch Processing System (LPS) was provided by the Kennedy Space Center (KSC).

The SAIL is used as an integration and verification laboratory. System level integration was completed in the SAIL before formal verification. As new elements or design changes are implemented on the Space Shuttle, the SAIL is utilized for integration and test prior to formal verification. The Phase I breadboard SAIL was activated in the 1973 time frame. This allowed early installation of laboratory test systems, integration of early flight subsystems, and accomplishment of laboratory performance testing. Major SSP activities supported by SAIL included Phase II ALT, Phase III Orbital Flight Test (OFT), and Phase IV Mission Support. A significant activity between the completion of Phase II ALT and start of Phase III OFT was the Operational Flight Test Changeover which involved complete replacement of the avionics, bays, and wire harnesses.

Other significant support activities included: LPS I&T with the SAIL flight system, pre-acceptance test of the Remote Manipulator System (RMS) (prior to delivery of the first "arm"), Ku-band subsystem integration and test, and multi-function electronic display system I&T. During the three phases of SAIL subsequent to Phase I, two test stations were utilized. The Space Shuttle test station was configured with flight qualifiable or flight- like avionics hardware in a multi-string configuration. This hardware was in a three-dimensional mock-up consisting of a cockpit, forward equipment bays, and aft equipment bays. Wire harnesses for this mock-up were flight configuration (length, size, material, and routing) except where SAIL facility limitations dictate otherwise. Figure 5.3-1 illustrates the vehicle layout in the SAIL Shuttle Test Station. The SAIL Shuttle Test Station Orbiter Flight System was designated Orbiter Vehicle (OV)-095. The Guidance, Navigation, and Control (GN&C) test station utilizes flight-type hardware mounted in racks connected with non-flight cabling. The test station supported GN&C ascent and limited on-orbit verification testing. The need for the GN&C test station was due to the overall verification test workload. The GN&C test station was decommissioned in the 1983 time frame and recommissioned in the 1993 time frame, and later decommissioned, due to changes in SSP requirements. Figure 5.3-2 illustrates the SAIL Mission Capability.





Title:

**Crew Exploration Vehicle (CEV) Avionics Integration  
Laboratory (CAIL) Independent Analysis**

Page #:  
21 of 39

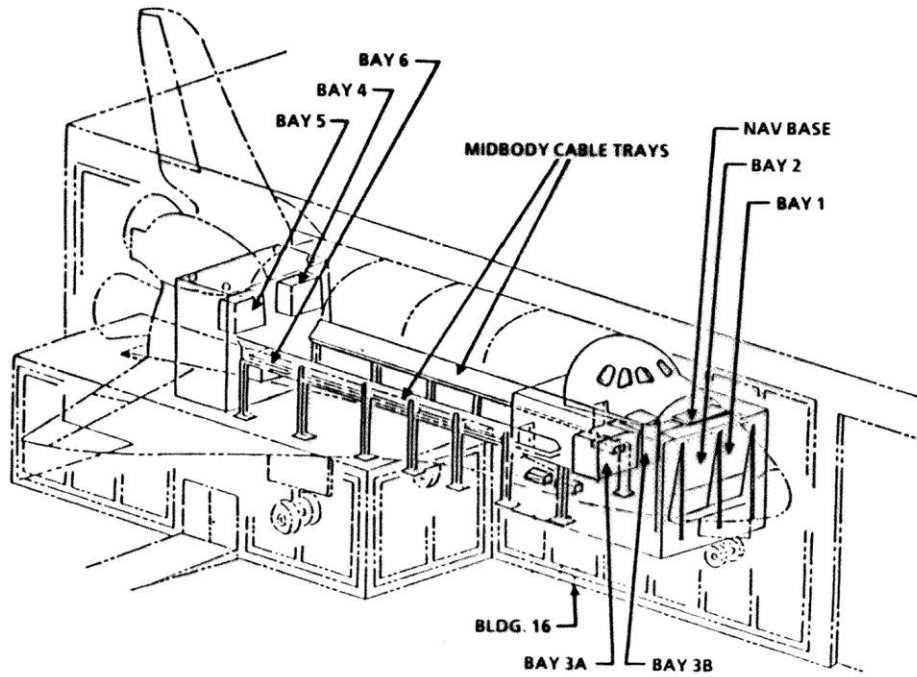

Figure 5.3-1. SAIL Shuttle Test Station Vehicle Layout



Title:

**Crew Exploration Vehicle (CEV) Avionics Integration  
Laboratory (CAIL) Independent Analysis**

Page #:  
22 of 39

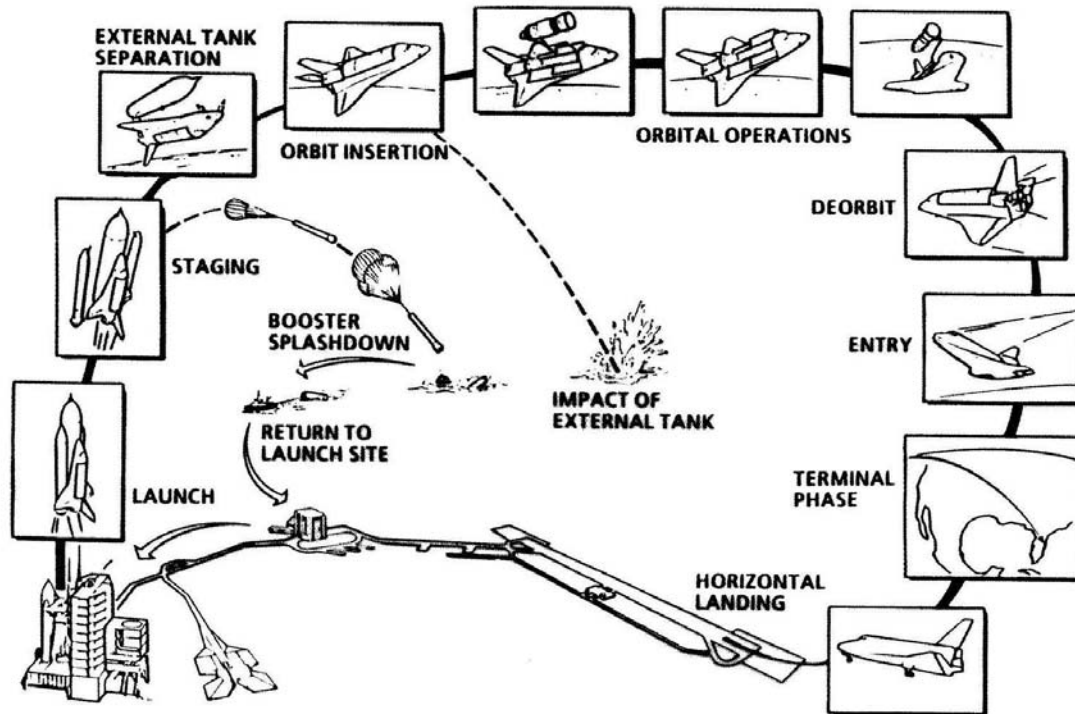

**Figure 5.3-2. SAIL Mission Capability**

Overall, the SAIL is a central facility where avionics and related flight hardware (or simulations of this hardware), flight software, flight procedures, and associated GSE are brought together for integration and mission verification testing. The SAIL supports avionics integration, test, and verification from pre-launch to abort phases such as Return-To-Launch Site (RTLS), and landing and roll-out. The SAIL configuration supports total integration of the Orbiter avionics, Shuttle Mated Elements, Space Shuttle LPS, and Space Shuttle payloads, and near real-time mission support.

Top-level functions for the SAIL are:

1. Full Orbiter ship set of flight configuration avionics.
2. Sufficient mated element flight configuration avionics to check all interfaces.
3. Subsystem to subsystem integration that make up the flight systems.
4. Hardware/software flight system integration to verify mission capability.
5. Formal test operations and failure reporting.
6. Rigorous quality control and configuration management.

	<b>NASA Engineering and Safety Center Report</b>	Document #: <b>RP-08-31</b>	Version: <b>1.0</b>
Title: <b>Crew Exploration Vehicle (CEV) Avionics Integration Laboratory (CAIL) Independent Analysis</b>			Page #: 23 of 39

7. Electrical interfaces and physical space to accommodate payload testing.
8. Located at JSC to use Government facilities.

The SAIL objectives include:

- Systems Verification
  - evaluation of subsystem interfaces
  - hardware and software integration
  - validation of vehicle ground checkout software
  - evaluation of redundancy management
  - determination of system limitations
  - mated element integration
  - launch processing system integration
- Mission Verification
  - hardware and software capability
  - flight operating procedures such as in-flight maintenance
- Operational Support
  - real-time mission support
  - payload integration
  - anomaly investigation

The SAIL flight system (OV-095) configuration tracks and complies with the vehicle flight configuration. This includes the electrical power distribution and control; displays and controls; GN&C; data processing; mated elements [Space Shuttle Main Engine (SSME), Solid Rocket Booster (SRB), and External tank ET]; payload interfaces; caution & warning; RMS; range safety; and Orbiter wire harness. The philosophy relative to non-avionics was anything that exercised flight software where it was not practical to have flight hardware would be simulated in the SAIL non-avionics simulation. For Ku-Band, the SAIL provided integration within the subsystem as well as subsystem-to-system level integration. Figure 5.3-3 shows the Space Shuttle test station, including the SAIL flight system. Figure 5.3-4 shows the middeck of the forward avionics bays. Figure 5.3-5 shows the aft avionics bays with two SSME controllers. Figure 5.3-6 shows the LPS. Figures 5.3-7 and 5.3-8 show the new/upgrade of the Test Operations Center and digital strip chart recorders.



Title:

**Crew Exploration Vehicle (CEV) Avionics Integration  
Laboratory (CAIL) Independent Analysis**

Page #:  
24 of 39

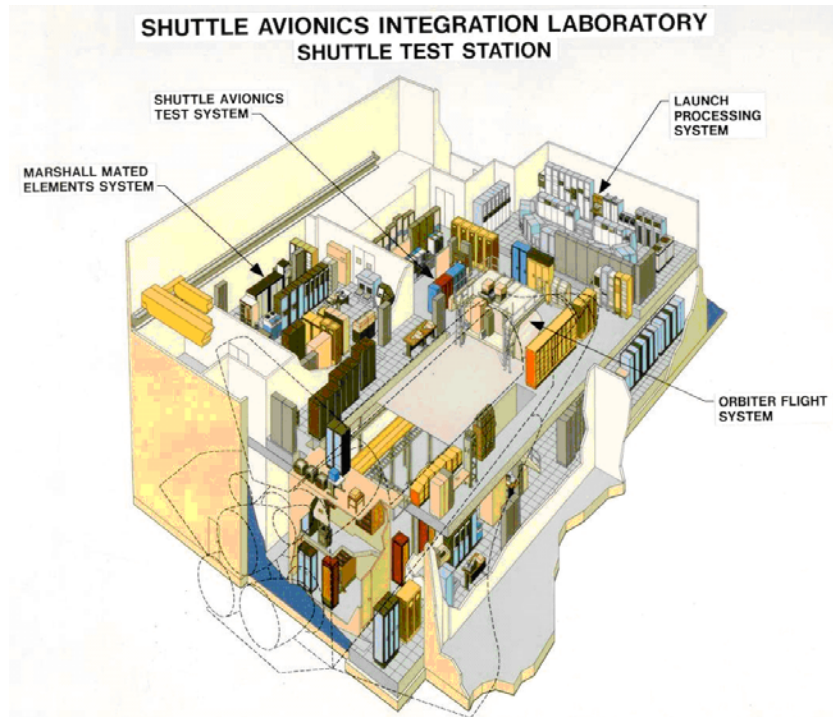

**Figure 5.3-3. Shuttle Test Station, including the SAIL Flight System**



**Figure 5.3-4. Middeck of the Forward Avionics Bays**





**NASA Engineering and Safety Center  
Report**

Document #:  
**RP-08-31**

Version:  
**1.0**

Title:

**Crew Exploration Vehicle (CEV) Avionics Integration  
Laboratory (CAIL) Independent Analysis**

Page #:  
25 of 39

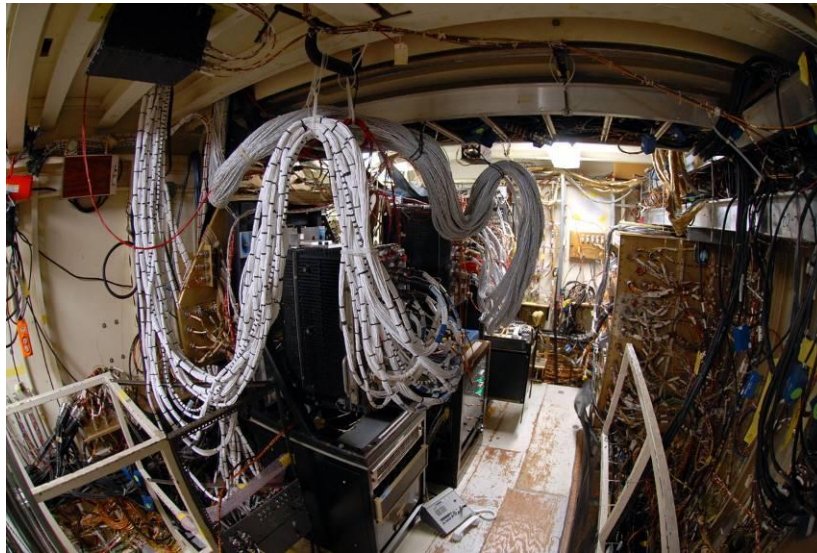

**Figure 5.3-5. Aft Avionics Bays with Two SSME Controllers**



**Figure 5.3-6. Launch Processing System**



**NASA Engineering and Safety Center  
Report**

Document #:  
**RP-08-31**

Version:  
**1.0**

Title:

**Crew Exploration Vehicle (CEV) Avionics Integration  
Laboratory (CAIL) Independent Analysis**

Page #:  
26 of 39



**Figure 5.3-7. Test Operations Center**



**Figure 5.3-8. Digital Strip Chart Recorders**

The overall verification process was a joint effort of civil service and contractor personnel. This effort was organized by engineering teams usually led at the subsystem level. These teams were part of the SAIL test team, as required, and participated from requirements definition through test procedure development, test execution, data analysis, and problem identification and correction/retest. Figure 5.3-9 illustrates the verification process flow.

	<b>NASA Engineering and Safety Center Report</b>	Document #: <b>RP-08-31</b>	Version: <b>1.0</b>
Title: <b>Crew Exploration Vehicle (CEV) Avionics Integration Laboratory (CAIL) Independent Analysis</b>		Page #: 27 of 39	

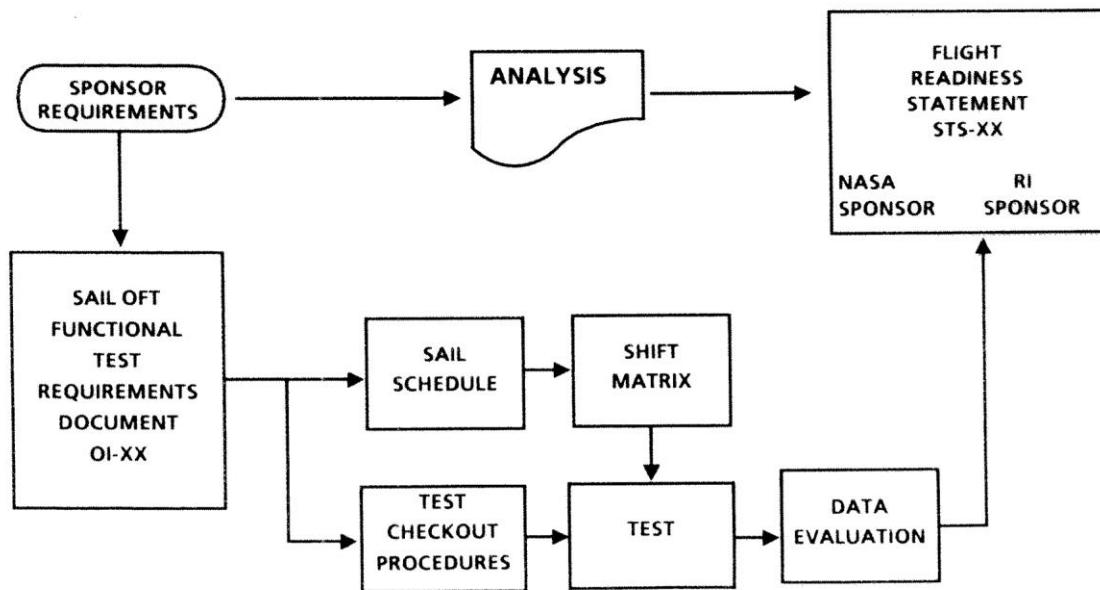

**Figure 5.3-9. SAIL Verification Process Flow**

The avionics verification process began when the software was released from the software production/reconfiguration facility and delivered to the SAIL. It was then integrated and closed-loop tested, with the avionics flight hardware in simulated mission sequences. Actual flight procedures/flight data files were integrated as appropriate into the SAIL Integrated Test and Checkout Procedures (ITCP). One purpose of the SAIL testing was to assure the avionics flight hardware and software would safely perform the upcoming mission. The process includes the verification of all hardware and software changes since the previous flight and the re-verification of the base software capabilities when new software Operational Increment (OI) was released for integration and test in the SAIL. One of the key elements of the verification process was the audit trail and accountability for all hardware and software changes from requirements to flight readiness. This is implemented through avionics engineering teams who represent ascent, on-orbit, descent, avionics services, and data processing. An avionics flight system team also integrates across the other operations teams. The SAIL test requirements were coordinated through each of the avionics teams with a starting point of "what verification testing do you require in order to sign a flight readiness statement for your area of responsibility?" One part of the process was an evaluation of all hardware and software changes in the respective area of responsibility, and a definition of the type of test required to verify the respective system. The appropriate hardware changes/modifications were installed in the SAIL. These tests were not designed to be part of a test series on the actual flight vehicle.

	<b>NASA Engineering and Safety Center Report</b>	Document #: <b>RP-08-31</b>	Version: <b>1.0</b>
Title: <b>Crew Exploration Vehicle (CEV) Avionics Integration Laboratory (CAIL) Independent Analysis</b>			Page #: 28 of 39

Overall, SAIL provided the capability to identify problems and implement and test corrective action using an integration/verification laboratory rather than the utilizing an Orbiter. Approximately 300 software problems and approximately 50 hardware problems were identified as a result of integration and test in the SAIL prior to the first operational flight test.

### 5.3.1 SAIL Summary

In summary, the SAIL provided the capability to:

1. Verify the systems functional and compatibility of the integrated Orbiter avionics and the associated software.
2. Verify the human/machine and avionics interfaces, integrated functions, avionics capability of the Orbiter, the mated elements (SSME, SRB, and ET) and the LPS.
3. Verify the avionics interfaces between payloads and the Orbiter.
4. Perform systems level investigations and verifications for mission unique software, mission functional requirements, operational anomalies, and effects of system design changes.

### 5.4 CAIL Concept

The CAIL concept is nearly identical to the SAIL approach. It is envisioned as a high fidelity, human-in-the-loop, and closed-loop flight simulation environment for the CEV avionics integration testing, which can execute mission scenario, ground and flight, nominal and off-nominal conditions.

The Orion CAIL team identified the CAIL's primary functions<sup>1</sup>:

- Integration testing of the CEV avionics hardware and software and associated internal and external CEV interfaces.
- CxP element-to-element integration testing as the CEV element.
- Test and analysis operational support during CEV missions.

The Orion CAIL team identified CAIL's secondary functions<sup>2</sup>:

- Artifacts of a high fidelity flight-configuration test rig.
- Engineering evaluation of proposed designs or subsystem/software changes.

---

<sup>1</sup>Section 10.0, Reference 3

<sup>2</sup>Section 10.0, Reference 3



	<b>NASA Engineering and Safety Center Report</b>	Document #: <b>RP-08-31</b>	Version: <b>1.0</b>
Title: <b>Crew Exploration Vehicle (CEV) Avionics Integration Laboratory (CAIL) Independent Analysis</b>			Page #: 29 of 39

- Crew training and procedures checkout.

The NESC team commended the Orion CAIL team for recognizing the need to set a priority of CAIL functions and for limiting the scope of new demands. Without these controls, the CAIL system would quickly exceed the available resources (e.g. cost and schedule). Although the outbriefs indicated there would be two production and one development/maintenance CAIL rigs, the Orion CAIL team noted the program plan includes three identical production rigs and no development/maintenance rig. The reason for this change was the projected increased non-recurring engineering cost of the development/maintenance rig.

A key assumption made by the Orion CAIL team was that all avionics, software and GN&C subsystems delivered to CAIL will have been verified at the component and/or assembly level. This implies that there will be minimal development activities in the CAIL. To be more precise, the elements delivered to the CAIL will already have been operating at an entire system level and thus CAIL is not the first time the elements operate at a system level. Figure 5.4-1 indicates the CEV development flow is vertical (low- to high-level).

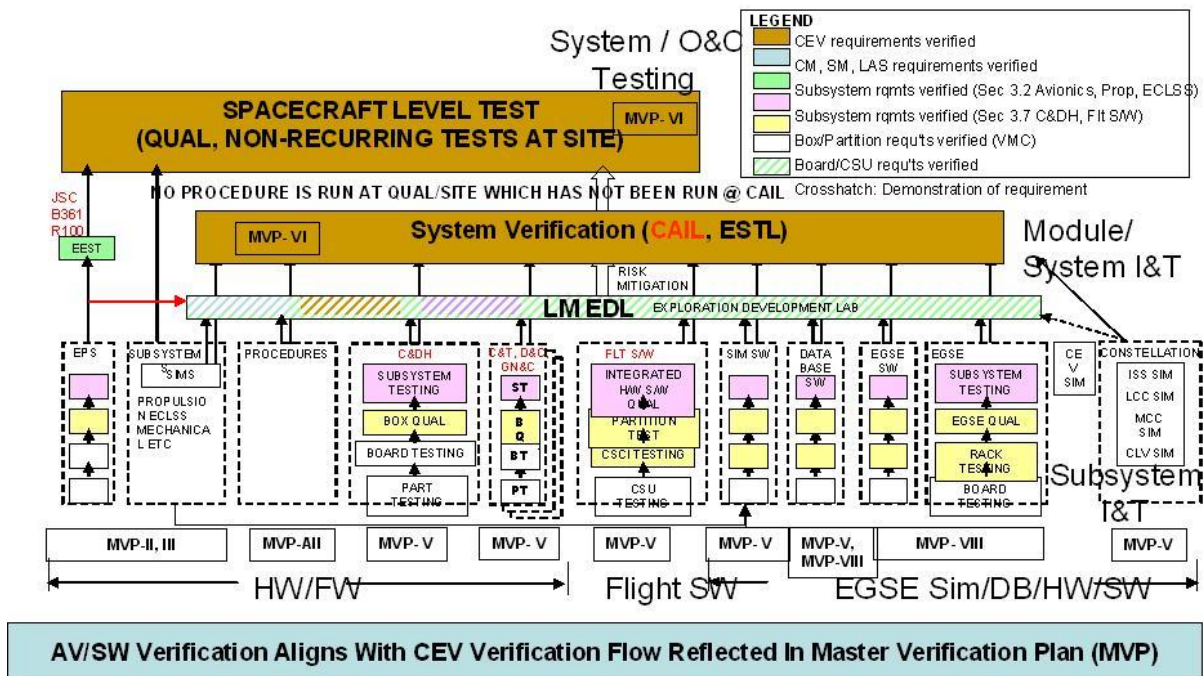

**Figure 5.4-1. CEV Development Flow**

	<b>NASA Engineering and Safety Center Report</b>	Document #: <b>RP-08-31</b>	Version: <b>1.0</b>
Title: <b>Crew Exploration Vehicle (CEV) Avionics Integration Laboratory (CAIL) Independent Analysis</b>		Page #: 30 of 39	

The NESC team focused on the depicted flow of elements into the system verification [CAIL, Electronics Systems Test Laboratory (ESTL)] and the LM EDL. The NESC team was expecting a more iterative process as shown in the SAIL or evolving process as discussed in the Flat-Sat approach. Additionally, the EDL is positioned in the development flow as the Flat-Sat, and therefore could construe that it performs a similar function. However, it was noted by the Orion CAIL team that the EDL is not dedicated to the development process rather the purpose is defined by LM as “Develop and apply technology” and “Make Constellation successful”<sup>3</sup>. Clearly, the development function will make CxP successful, but the development and apply technology is more focused on future CxP elements and can compete for utilization time. The EDL is an “investment” into CxP by LM and contractor partners; essentially “LM builds it, NASA *can* use it”. It was not possible to determine the exact role the EDL will play in the flight avionics system development. It is important to note that there are four vehicle management computer test beds planned for avionics and software development and verification testing at the subsystem level. Thus, the Orion CAIL team has several options to fill the role of the development tool: dedicate the EDL, increase the fidelity of a vehicle management computer test beds, or decrease the fidelity of one of the CAIL systems.

The requirement<sup>4</sup> of the CAIL portability was raised during CxP and NESC team discussions. Portability implies a level of modularity that does not exist in the flight article and appears contrary to the necessity to duplicate the flight system. When conflicting requirements exist, a priority must be established to guide the desired result. A review of the Spacecraft Test & Verification Facility System Requirements Document (CEV-T-082100) did not confirm a clear hierarchy.

#### 5.4.1 CAIL Summary

The strategic approach of the CAIL is similar to the SAIL approach. Essentially, the approach is to create a tool of sufficient fidelity to enable a high fidelity, human-in-the-loop, closed-loop flight simulation environment for CEV avionics integration testing with the intent of reducing the risk of undiscovered safety discrepancies residing in the flight avionics system. Rigor in fidelity and configuration control required for verification of first mission and subsequent missions is cumbersome and not optimized for system development. A key assumption is the flight units delivered to the CAIL will be ready for system level verification and beyond development phase. The CAIL is a tool enabling formal flight readiness verification or pre-verification for formal verification on the flight article.

<sup>3</sup>Exploration Development Lab (EDL) Overview Presentation (Slide 6), Lockheed Martin-owned and operated for Constellation Program and internal IR&D of Exploration Capabilities.

<sup>4</sup>“Level A Functional Requirements, For the Crewed Exploration Vehicle (CEV) Avionics Integration Lab (CAIL)”, 3.3.3 Transition to Sustained Operations: The CAIL test system(s) shall be portable.

	<b>NASA Engineering and Safety Center Report</b>	Document #: <b>RP-08-31</b>	Version: <b>1.0</b>
Title: <b>Crew Exploration Vehicle (CEV) Avionics Integration Laboratory (CAIL) Independent Analysis</b>		Page #: 31 of 39	

The development process from concept to flight system will utilize different tools as the design matures and the CAIL verification function must be aligned and coordinated with other planned end-to-end tools. It was not evident that the interaction of the different Orion development tools has been sufficiently coordinated. The Orion CAIL team recognized the coordination necessity and conducted a Technical Interchange Meeting (TIM) on the end-to-end testing in July 2007 and a follow-on meeting that occurred in the spring of 2008.

## 5.5 Software Test Beds

During a development process a large portion of the time will be spent on software development, test and verification with the hardware. The overall development plan will directly influence the test bed fidelity and indirectly defines the scope and needs of the laboratory customers. For a software test bed there are a large number of users (simulation developers, hardware and software integration and test engineers, ground operations and ground application developers, mission operators, external hardware interface engineers, and system integration engineers). The conglomerate of users dictates a tightly coordinated delivery scheduling and user scheduling.

### 5.5.1 An Example of Distributed Software Development Analysis, Evaluation, Integration, and Test

Test beds can be supplied to external developers. The James Webb Space Telescope (JWST) exported project-owned test beds to the telescope instrument developers. The test beds consisted of commercial off-the-shelf (COTS) processors, high-fidelity hardware interfaces, the GSFC-developed Command and Data Handling (C&DH) flight software, the actual mission operations ground software, and an identical software development tool suite used at GSFC. The external developer is able to deliver flight-ready instrument software, instrument integration tests, and a set of mission procedures and the mission operations database. These deliverables are verified at their development site in the instrument operational environment.

The instrument developers are using the test beds to support flight software development, environment test development, integration test development, system test procedures, and mission operations database and procedures. The exported test bed supported high-fidelity software interface verification with the C&DH, early high-fidelity subsystem hardware and software integration test development, mission operations database development, and mission operations process development.

The GSFC developer is able to deliver C&DH software updates to the external developers for early subsystem integration and verification. A side effect of the exported test bed was the increased fidelity of communication between the external developers and GSFC. A shared knowledge of the test system developed due to the similarity of the development and test

	<b>NASA Engineering and Safety Center Report</b>	Document #: <b>RP-08-31</b>	Version: <b>1.0</b>
Title: <b>Crew Exploration Vehicle (CEV) Avionics Integration Laboratory (CAIL) Independent Analysis</b>		Page #: 32 of 39	

environments. Shared knowledge of the JWST system developed due to the consistent system visibility. Solutions to shared issues were solved by involving all the developers. Expertise gained at one site was shared by the other sites. Late development at one site quickly "caught up" with the integration schedule through this information sharing, which in turn greatly reduced the learning-curve on the test beds.

## 5.6 Comparison Summary of SAIL, CAIL, and Flat-Sat

Figure 5.1-2 indicates the different purposes the Flat-Sat, SAIL and CAIL tools provide in relationship to the development cycle:

- The Flat-Sat is a tool to mature a single mission concept into a flight avionics system and associated ground controller. The Flat-Sat fidelity progression enables rapid design maturation and earlier delivery enables more time on system with an opportunity to identify and correct discrepancies.
- For the SAIL/CAIL tools, a high fidelity and rigorous controlled tool enables first mission and subsequent mission flight avionics verification with a high degree of confidence. The tools' high fidelity enables rapid re-verification from mission to mission and provides programmatic risk management along with technical risk mitigation.

Figure 5.1-2 indicates the different purposes the Flat-Sat, SAIL and CAIL tools provide in relationship to the development cycle. The Flat-Sat is a tool to mature a mission concept into a flight avionics system and associated ground controller. Then, the software development along with mission operations support follows. The Flat-Sat initial lower fidelity enables rapid maturity of design and lower system fidelity traded for earlier delivery enables more time on system and an opportunity to identify and correct discrepancies. Due to the single mission dictating that the formal verification process must occur on the flight article, there is no need for formal verification (and thus high fidelity) on the Flat-Sat tool.

For the SAIL/CAIL tools, a high fidelity and rigorous controlled tool enables first mission and subsequent mission flight avionics verification with high degree of confidence. The tools' high fidelity enables rapid re-verification from mission to mission and provides programmatic risk management along with technical risk mitigation.

These tools are not exclusive; rather, they are complimentary in mitigating different risks encountered along the development from concept to operations. The NESC team noted that, based on their experience, the successful projects are keenly aware of their available tools' abilities and limitations and can quickly adjust to the dynamically-changing risk priority and

	<b>NASA Engineering and Safety Center Report</b>	Document #: <b>RP-08-31</b>	Version: <b>1.0</b>
Title: <b>Crew Exploration Vehicle (CEV) Avionics Integration Laboratory (CAIL) Independent Analysis</b>		Page #: 33 of 39	

hardware/software configurations of the development phase. Therefore, it is more important to have a complete tool set, than selecting any one individual tool.

## 6.0 Comments from NESC Preliminary Briefing (March 17, 2008)

It was observed by the NESC team that the requirement for “geometrically identical” in the CAIL was not addressed. This requirement sets a threshold on the risks that the CAIL must duplicate and thus provide the opportunity to discover these risks/discrepancies. To be quantitative of the benefit/cost of this risk threshold, it would require a statistical analysis of numerous past projects based on the individual projects’ risk, fidelity of their tools, and types of risks discovered. Unfortunately, this data is not known to exist in any collective format. Based on experience and knowledge of the development process, a general relationship between risk and system fidelity can be identified. At the highest level, or first order, the design is verified at a system level by ensuring the results of the different control loop interactions are as intended under nominal conditions and a functional representative system will be required. The functional representative system can be black boxes and simulators with no attempt at harness duplication and implementation specific nuances. At the second order, the performance around the individual control loops is verified under all operational conditions and thus an accurate representation of the implementation voltage variation and delays will be required. At this second level, only the single control loop requires flight-like assemblies and wires to duplicate the *intentional* implementation variances and the interacting systems can be simulated. At the third order, the *unintentional* interactions between the systems’ are verified and thus high fidelity hardware with geometrically identical configuration is required. At this lower level, the intent is to identify the subtle environmental induced interactions such as subsystem-to-subsystem thermal interactions, electromagnetic interactions and mechanical motion interactions. It is important to point out the first two levels are necessary to thoroughly characterize the normal system variations thus enabling the ability to identify the more subtle unintentional interactions. For Constellation, the optimal solution is a complete set of development test beds or tools that address the risks at various levels of the design.

Another CxP/NESC team discussion item related to the philosophy of requiring all verification on the flight article or allowing verification on a high fidelity flight-like article. Clearly, the NASA philosophy of “test as you fly, fly as you test” holds true in this case and it is desirable to complete all verification on the flight article. Completing all verification on the flight article mitigates the class of risks that may be unique to that individual flight article. However, there are some tests that require specific inputs to close the control loop or conditions that require inducing failures or simulated failures. For the Space Shuttle's size and complexity, system level verification on the flight vehicle was not practical. In these cases, it is a balance of the risk of disassembling the flight article to implement the unique inputs versus the risk of the unknown difference between the flight article and the high fidelity flight-like test unit. There are certain

	<b>NASA Engineering and Safety Center Report</b>	Document #: <b>RP-08-31</b>	Version: <b>1.0</b>
Title: <b>Crew Exploration Vehicle (CEV) Avionics Integration Laboratory (CAIL) Independent Analysis</b>		Page #: 34 of 39	

attitude control system tests where it is lower risk to verify on a high fidelity flight-like article. Programmatic risks (e.g. schedule and cost) or flight article availability must be weighed against the risk of not completing all verifications on the flight article. Other risks that must be evaluated include usage limits for the flight article and cost, schedule and complexity of vehicle-in-the-loop testing. The risks must be considered on a case by case basis.



	<b>NASA Engineering and Safety Center Report</b>	Document #: <b>RP-08-31</b>	Version: <b>1.0</b>
Title: <b>Crew Exploration Vehicle (CEV) Avionics Integration Laboratory (CAIL) Independent Analysis</b>			Page #: 35 of 39

## 7.0 Findings, Observations, and Recommendations

### 7.1 Findings

The following NESC team findings were identified:

- F-1. A coordinated, end-to-end, box to system level development and verification process was not evident for the proposed CAIL concept.
- F-2. The CAIL assumption is that the flight subsystems will be matured for the *system level* verification.
  - Assumes returning to the previous level is not required.
- F-3. The Flat-Sat and SAIL approaches are two different tools designed to mitigate different risks.
  - Flat-Sat is designed to develop a mission concept into a flight avionics system and associated ground controller.
  - SAIL is designed to validate the flight avionics system.
  - The approaches are complimentary in addressing both the system development risks and mission verification risks.

### 7.2 Observations

The following NESC team observations were identified:

- O-1. Based on the team’s experience, required/requested peak usage of an integration lab typically exceeds lab availability even in a multi-shift operation.
- O-2. Both the CAIL and the EDL material did not refer to an intentional effort to provide an engineering team knowledge transfer to ground operations and mission operations teams.
- O-3. Coordination of the verification process is essential to avoid missing key risks and to be prepared for schedule deviations.
- O-4. Partitioning of integration facility into subsystem integration labs allows for “cloning” and “export” to external developers.
- O-5. The CAIL and the SAIL differ in the fidelity of the propulsion hardware and software interface systems.

	<b>NASA Engineering and Safety Center Report</b>	Document #: <b>RP-08-31</b>	Version: <b>1.0</b>
Title: <b>Crew Exploration Vehicle (CEV) Avionics Integration Laboratory (CAIL) Independent Analysis</b>		Page #: 36 of 39	

### 7.3 Recommendation

The following NESC team recommendation was made:

- R-1.** Define, document, and manage a detailed interface between the design and development (EDL and other integration labs) to the verification laboratory (CAIL). [*F1, F2, O3*]
- Interfaces (flight software/hardware, schedule deviations, system discrepancies)
  - Typically defined and documented by CAIL PDR

### 8.0 Definition of Terms

Corrective Actions	Changes to design processes, work instructions, workmanship practices, training, inspections, tests, procedures, specifications, drawings, tools, equipment, facilities, resources, or material that result in preventing, minimizing, or limiting the potential for recurrence of a problem.
Development	Process of functional testing, interface testing, open-loop testing and close-loop testing necessary to mature a concept to operation system
Finding	A conclusion based on facts established during the assessment/inspection by the investigating authority.
Flight Avionics System	All electrical/electronic systems that will fly on the vehicle.
Ground Controller	Ground electrical/electronic systems, tools, and procedures that enable the development and operation of the Flight Avionics System.
Lessons Learned	Knowledge or understanding gained by experience. The experience may be positive, as in a successful test or mission, or negative, as in a mishap or failure. A lesson must be significant in that it has real or assumed impact on operations; valid in that it is factually and technically correct; and applicable in that it identifies a specific design, process, or decision that reduces or limits the potential for failures and mishaps, or reinforces a positive result.
Observation	A significant factor established during this assessment that supports and influences the conclusions reached in the statement of Findings and Recommendations.



	<b>NASA Engineering and Safety Center Report</b>	Document #: <b>RP-08-31</b>	Version: <b>1.0</b>
Title: <b>Crew Exploration Vehicle (CEV) Avionics Integration Laboratory (CAIL) Independent Analysis</b>		Page #: 37 of 39	

Problem	The subject of the independent technical assessment/inspection.
Recommendation	An action identified by the assessment/inspection team to correct a root cause or deficiency identified during the investigation. The recommendations may be used by the responsible C/P/P/O in the preparation of a corrective action plan.
Root Cause	Along a chain of events leading to a mishap or close call, the first causal action or failure to act that could have been controlled systemically either by policy/practice/procedure or individual adherence to policy/practice/procedure.
Verification	Formal process of demonstrating a design is flight ready and is assumed to be interchangeable in the general sense to verification, validation and certification.

## 9.0 List of Acronyms

ALT	Approach and Landing Test
AMD	Advanced Mirror Development
BFCS	Backup Flight Control System
C&DH	Communications and Data Handling
CAIL	CEV Avionics Integration Laboratory
CDR	Critical Design Review
COTS	Commercial-Off-The-Shelf
CxP	Constellation Program
EDL	Exploration Development Laboratory
EOS	Earth Observing System
ESMD	Exploration Systems Mission Directorate
ESTL	Electronics Systems Test Laboratory
ET	External Tank
ETU	Engineering Test Unit
GN&C	Guidance, Navigation, and Control
GSE	Government Supplied Equipment
GSFC	Goddard Space Flight Center
I&T	Integration and Test
ITCP	Integrated Test and Checkout Procedures
JPL	Jet Propulsion Laboratory
JSC	Johnson Space Center

	<b>NASA Engineering and Safety Center Report</b>	Document #: <b>RP-08-31</b>	Version: <b>1.0</b>
Title: <b>Crew Exploration Vehicle (CEV) Avionics Integration Laboratory (CAIL) Independent Analysis</b>			Page #: 38 of 39

JWST	James Webb Space Telescope
KSC	Kennedy Space Center
LM	Lockheed Martin
LPS	Launch Processing System
LRO	Lunar Reconnaissance Orbiter
MMES	Marshall Mated Elements System
NASA	NASA Aeronautics and Space Administration
NESC	NASA Engineering and Safety Center
NRB	NESC Review Board
OFT	Orbital Flight Test
OI	Operational Increment
OV	Orbiter Vehicle
PDR	Preliminary Design Review
RMS	Remote Manipulator System
RTLS	Return To Launch Site
SAIL	Shuttle Avionics Integration Laboratory
SDO	Solar Dynamics Observatory
SME	Subject Matter Expert
SRB	Solid Rocket Booster
SSME	Space Shuttle Main Engine
SSP	Space Shuttle Program
T&V	Test & Verification
TIM	Technical Interchange Meeting
TRMM	Tropical Rainfall Measuring Mission
VEST	Vehicle Electrical System Test
WMAP	Wilkinson Microwave Anisotropy Probe

## 10.0 References

1. NESC Constellation Avionics Integrated Lab (CAIL) Independent Analysis Outbrief to NASA Headquarters, presented by Mitch Davis on March 17, 2008.
2. Project Orion Spacecraft Test & Verification Facility System Requirements Document (CEV-T-082100), CAIL, July 10, 2007.
3. CEV Avionics Integration Lab (CAIL) Overview to NESC CAIL Independent Analysis, Mr. Aaron Van Baalen, Orion, Avionics & Software Test and Verification Lead, February 27, 2007.
4. Shuttle Avionics Integration Laboratory (SAIL), presented by Bill Ritz on March 5, 2008.

	<b>NASA Engineering and Safety Center Report</b>	Document #: <b>RP-08-31</b>	Version: <b>1.0</b>
Title: <b>Crew Exploration Vehicle (CEV) Avionics Integration Laboratory (CAIL) Independent Analysis</b>		Page #: 39 of 39	

5. Statement of Work, CEV Avionics Integration Lab (CAIL), Attachment J-1, Section 6.4, Contract Number: NNJ06TA25C.
6. Exploration Development Lab (EDL) Overview Presentation, Lockheed Martin-owned and operated for Constellation Program and internal IR&D of Exploration Capabilities.

REPORT DOCUMENTATION PAGE				Form Approved OMB No. 0704-0188	
The public reporting burden for this collection of information is estimated to average 1 hour per response, including the time for reviewing instructions, searching existing data sources, gathering and maintaining the data needed, and completing and reviewing the collection of information. Send comments regarding this burden estimate or any other aspect of this collection of information, including suggestions for reducing this burden, to Department of Defense, Washington Headquarters Services, Directorate for Information Operations and Reports (0704-0188), 1215 Jefferson Davis Highway, Suite 1204, Arlington, VA 22202-4302. Respondents should be aware that notwithstanding any other provision of law, no person shall be subject to any penalty for failing to comply with a collection of information if it does not display a currently valid OMB control number.					
<b>PLEASE DO NOT RETURN YOUR FORM TO THE ABOVE ADDRESS.</b>					
1. REPORT DATE (DD-MM-YYYY) 01-02-2009		2. REPORT TYPE Technical Memorandum		3. DATES COVERED (From - To) May 2008- May 2008	
4. TITLE AND SUBTITLE Crew Exploration Vehicle (CEV) Avionics Integration Laboratory (CAIL) Independent Analysis				5a. CONTRACT NUMBER	
				5b. GRANT NUMBER	
				5c. PROGRAM ELEMENT NUMBER	
6. AUTHOR(S) Davis, Mitchell, L.; Aguilar, Michael, L.; Mora, Victor, D.; Regenie, Victoria, A.; Ritz, William, F.				5d. PROJECT NUMBER	
				5e. TASK NUMBER	
				5f. WORK UNIT NUMBER 510505.01.07.01.06	
7. PERFORMING ORGANIZATION NAME(S) AND ADDRESS(ES) NASA Engineering and Safety Center Langley Research Center Hampton, VA 23681-2199				8. PERFORMING ORGANIZATION REPORT NUMBER L-19577 NESC-RP-08-31/08-00451	
9. SPONSORING/MONITORING AGENCY NAME(S) AND ADDRESS(ES) National Aeronautics and Space Administration Washington, DC 20546-0001				10. SPONSORING/MONITOR'S ACRONYM(S) NASA	
				11. SPONSORING/MONITORING REPORT NUMBER NASA/TM-2009-215569	
12. DISTRIBUTION/AVAILABILITY STATEMENT Unclassified - Unlimited Subject Category 06 Avionics And Aircraft Instrumentation    Availability: NASA CASI (443) 757-5802					
13. SUPPLEMENTARY NOTES					
14. ABSTRACT Two approaches were compared to the Crew Exploration Vehicle (CEV) Avionics Integration Laboratory (CAIL) approach: the Flat-Sat and Shuttle Avionics Integration Laboratory (SAIL). The Flat-Sat and CAIL/SAIL approaches are two different tools designed to mitigate different risks. Flat-Sat approach is designed to develop a mission concept into a flight avionics system and associated ground controller. The SAIL approach is designed to aid in the flight readiness verification of the flight avionics system. The approaches are complimentary in addressing both the system development risks and mission verification risks. The following NESC team findings were identified: The CAIL assumption is that the flight subsystems will be matured for the system level verification; The Flat-Sat and SAIL approaches are two different tools designed to mitigate different risks. The following NESC team recommendation was provided: Define, document, and manage a detailed interface between the design and development (EDL and other integration labs) to the verification laboratory (CAIL).					
15. SUBJECT TERMS NESC, CEV, CAIL, SAIL, Flat-Sat, EDL, VEST, TRMM, WMAP, LRO					
16. SECURITY CLASSIFICATION OF:			17. LIMITATION OF ABSTRACT	18. NUMBER OF PAGES	19a. NAME OF RESPONSIBLE PERSON
a. REPORT	b. ABSTRACT	c. THIS PAGE			STI Help Desk (email: help@sti.nasa.gov)
UU	UU	UU	UU	44	19b. TELEPHONE NUMBER (Include area code) (443) 757-5802