

CORRECTED VERSION 8/25/08

Ares First Stage "Systemology" – Combining Advanced Systems Engineering and Planning Tools to Assure Mission Success

James Seiler, Manager, Ares I First Stage Systems Engineering, ATK
Fred Brasfield, Director, Ares I First Stage, ATK
Scott Cannon, Chief Engineer, Ares I First Stage, ATK

ABSTRACT

Ares is an integral part of NASA's Constellation architecture that will provide crew and cargo access to the International Space Station as well as low earth orbit support for lunar missions. Ares replaces the Space Shuttle in the post 2010 time frame. Ares I is an in-line, two-stage rocket topped by the Orion Crew Exploration Vehicle, its service module, and a launch abort system. The Ares I first stage is a single, five-segment reusable solid rocket booster derived from the Space Shuttle Program's reusable solid rocket motor. The Ares second or upper stage is propelled by a J-2X main engine fueled with liquid oxygen and liquid hydrogen. This paper describes the advanced systems engineering and planning tools being utilized for the design, test, and qualification of the Ares I first stage element. Included are descriptions of the current first stage design, the milestone schedule requirements, and the marriage of systems engineering, detailed planning efforts, and roadmapping employed to achieve these goals.

INTRODUCTION

To further the bounds of space exploration, NASA is developing a launch vehicle which draws heavily on the impressive success of the Space Shuttle Program reusable solid rocket motor (RSRM). To meet the challenge, the Ares first stage NASA team has structured integrated teams covering all major subsystems and system engineering tasks. NASA Marshall Space Flight Center is responsible for the overall launch vehicle including management of the first stage effort. As the prime contractor for the first stage, ATK is responsible for system engineering, subsystem design, development, qualification, and flight test. Following the System Requirements Review (SRR) in December 2006 and the Preliminary Design Review (PDR) in June 2008, the first full-scale static firing of the five-segment booster and the first suborbital flight test will occur in 2009. Motor qualification is scheduled to be complete in 2013, with the first manned flight scheduled for 2015. The design is built around maximizing the use of heritage hardware from the Space Shuttle.

The motor is adapted from the RSRM used on the Shuttle and uses the same motor case segments and propellant with a larger nozzle. Full-scale static testing of a similar five-segment motor has been accomplished. The range safety system (RSS) will be the same as that of the RSRM system with adaptations for the necessary changes in the Ares hardware. The aft section, including the aft skirt and thrust vector control (TVC) system, are unchanged from the Shuttle RSRM. As a result of the in-line vehicle architecture, new forward structure hardware is

being developed. Because of obsolescence and vehicle architecture changes, the avionics system will be new. The deceleration system will be redesigned to decelerate the five-segment motor such that water impact energy is the same as for the current four-segment RSRM. The major subsystems and the system approach are discussed in this paper.

FIRST STAGE DESIGN

The Ares first stage design is a logical adaptation of the proven RSRM used on the current Space Shuttle vehicle. The stage is recoverable and many of its components are reusable. Many of the heritage RSRM components, processes, and methodologies have been applied to the Ares I first stage. This approach permits the development and implementation of a very robust launch vehicle configuration in a timely manner. The stage consists of five major forward structural components necessary to mate with the upper stage, house the stage recovery systems, package the stage avionics, and attach to the propulsion system. The stage also provides the vehicle guidance authority via the TVC system during first stage ascent. The TVC system is contained in the aft skirt, which also supports the entire vehicle on the launch platform.

The major forward structures are the frustum, aeroshell, forward skirt extension (FSE), main parachute support structure (MPSS), and forward skirt (Figure 1).

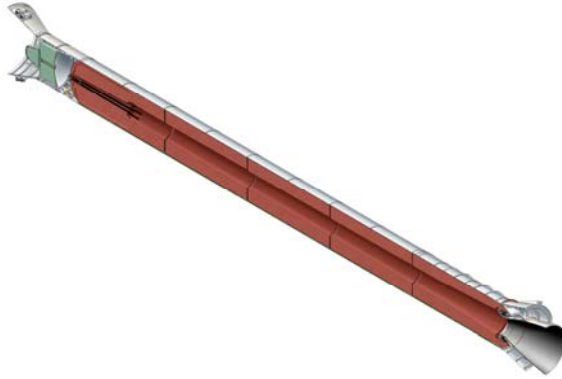

Figure 1. Ares First Stage

The frustum is the primary interface to the upper stage and transitions from the 146-in. diameter of the first stage to the 216-in. diameter of the upper stage. The frustum also provides protection for the J-2X engine bell and the aeroshell. The aeroshell is part of the recovery system and is mounted to the top of the FSE. Its primary purpose is to house the pilot and drogue parachute packs. The frustum and aeroshell are not reusable. The FSE and MPSS are integral components designed to accommodate the three main parachute packs and react loads induced by the drogue parachute and aeroshell jettison. The forward skirt provides mounting provisions for the stage avionics, access to the propulsion system safe and arm (S&A) device, and load carrying capability for the main parachutes. The FSE and forward skirt are reusable components.

At the heart of the stage architecture is a solid propulsion system derived from the highly reliable, four-segment RSRM. This propulsion system, referred to as RSRMV with the V representing five segments instead of the four segments utilized on RSRM, has been adapted for Ares by: 1) incorporating an additional casting segment, 2) configuring the propellant grain for optimal Ares performance, and 3) modifying the RSRM nozzle assembly to accommodate the increased mass flow rate. The RSRMV is capable of producing nearly 3.6 million pounds of vacuum thrust and, when combined with the J-2X upper stage, can lift in excess of 56,200 lbs to low earth orbit. The RSRMV maintains the same level of reusability as the current RSRM.

Five-segment Motor Design

The five-segment motor design was derived from the RSRM to retain the robust, human-rated features of the world's most reliable solid rocket

motor. The RSRM was designed with healthy factors of safety that are verified after every flight through rigorous inspections and hardware dissection. It is this heritage of hardware, along with systemic design and inspection processes, that have been carried forward to ensure the long-term success of the Ares first stage.

The proof-of-concept for the five-segment motor was a full-scale static test of a five-segment engineering test motor (ETM) that pushed design limits for burn rate, nozzle geometry, insulation exposure, and margins of safety. Wherever feasible, the RSRMV was configured as close as possible to RSRM within the parameters benchmarked by the ETM (Table 1).

Meeting performance demands and improving margins of safety beyond those of the already robust RSRM provided the basis for several key adaptations from RSRM.

Twelve fins in the propellant grain were utilized in the forward segment to achieve high initial thrust and then transition to reduced thrust levels during maximum dynamic pressure for the vehicle. The transition from fin to center perforated propellant grain in the forward segment was tapered to maximize structural margins of safety, which now exceed those of RSRM. Thrust characteristics resulting from the modified grain and updated nozzle design are shown in Figure 2.

Propellant for the RSRMV is a polybutadiene-acrylonitrile-acrylic acid polymer binder, epoxy curing agent, ammonium perchlorate (AP) oxidizer, and aluminum powder fuel. The AP is used in an unground and ground bimodal mixture.

Granular aluminum powder is used in the motor propellant. Small quantities of ferric oxide (Fe_2O_3) are added to tailor burn rate flexibility. The 86 percent solid RSRMV formulation is very similar to RSRM and ETM-3. Quantities of AP, aluminum, and Fe_2O_3 are shown in Table 2.

Table 1. RSRM, ETM, and RSRMV Design Comparison

	RSRM	ETM-3	RSRMV
Motor			
Overall Length (in.)	1,513.49	1,868.25	1,868.25
Case Diameter (in.)	146.08	146.08	146.08
Nozzle			
Throat Diameter (in.)	53.86	56.11	56.86
Exit Diameter (in.)	149.64	152.75	152.75
Expansion Ratio	7.72	7.41	7.22
TVC Vector Clearance at Throat (deg)	11.64	11.64	5.22
Ballistics			
Total Propellant Weight	1,106,000	1,366,000	1,383,000
Maximum Thrust	3,326,000	3,690,000	3,566,000

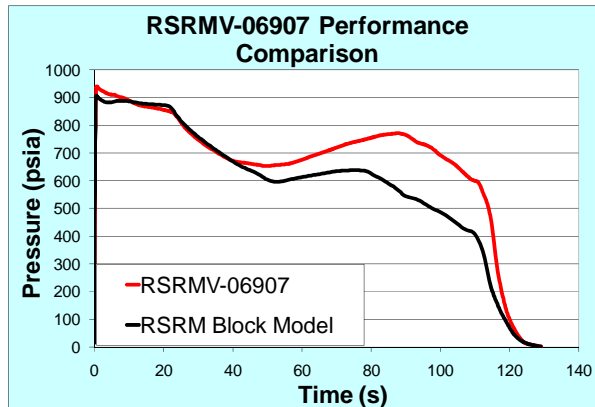

Figure 2. Thrust-time Trace for RSRM and RSRMV

Table 2. Propellant Formulation

Raw Material	Weight (%)	Function
AP	70 – Fe ₂ O ₃ *	Oxidizer
Aluminum Powder	16	Fuel
HB Polymer and Epoxy Resin	14	Binder curing liquid agent
(Fe ₂ O ₃)	*	Burn rate catalyst

*Percentage of Fe₂O₃ is determined by burn rate tailorability required

The majority of the RSRM nozzle components were retained. TVC clearances were maintained to ensure vehicle controllability for angles up to 4.5 degrees. The throat diameter was increased from 53.86 in. (RSRM) to 56.86 in. to provide the high levels of thrust needed at liftoff. Metallic throat, inlet, and forward exit cone housings were also increased in diameter to accommodate throat diameter increase and provide for further increases in nozzle thermal performance factors, making the RSRMV nozzle the most robust nozzle ever designed for flight.

A new insulator material consisting of p-phenylene-2, 6-benzobisoxazole fibers and nitrile butadiene rubber was chosen to provide a 10 percent reduction in weight and maintain long-term supplier viability while still meeting demonstrated structural and thermal performance requirements. All other components, such as the S&A, igniter, and case hardware were carried over directly from RSRM to preserve the demonstrated heritage and minimize development efforts.

The robust nature of the RSRMV also provides opportunities for weight reduction after initial static tests. Insulator and exit cone liner thicknesses may be reduced if performance is within expected ranges. Slight increases in reusability risk could facilitate reductions in

thermal protection system insulation offering further weight reduction opportunities.

Forward Structures Assembly

The forward structures assembly functions as the interface between the forward end of the RSRMV and the aft end of the upper stage. The assembly is comprised of several discrete structures including the forward skirt, MPSS, FSE, aeroshell, frustum, and separation joints. The baseline material for these structures is aluminum or composite. Each structure is shown in Figure 3.

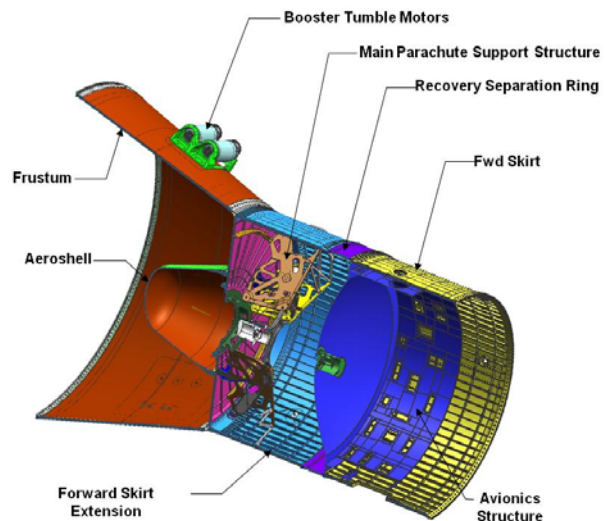

Figure 3. Forward Structures Assembly

The majority of the Ares first stage avionics components are housed in the internal volume of the forward skirt. As these avionics components are to be recovered and reused, the forward skirt is designed to preclude the intrusion of seawater into its internal cavity during and after splashdown. In addition, the forward skirt must resist large axial, shear, and bending body loads during ascent. Finally, the forward skirt reacts the descent loads of the three main reentry parachutes through hard attach points located on the forward end of the skirt.

The MPSS is housed inside of, and works in conjunction with, the FSE. The three main parachutes, which are deployed during descent, are packed inside the FSE and are supported by the MPSS. In addition, the MPSS provides a 3-D structural space frame that reacts the loads generated from the drogue chute deployment. Like the forward skirt, the FSE is also designed to resist the vehicle body loads during ascent.

The aeroshell is mounted atop the FSE and serves two primary functions. First, it protects the

pilot and drogue chutes from the high aerodynamic and thermal loads generated during reentry. Second, it is used to deploy the pilot and drogue chutes upon acceleration away from the FSE at the appropriate reentry altitude. It has no ascent loads of any significance.

The frustum provides a structural interface between the first stage and the upper stage and resists the large ascent body loads. After separation of the first stage from the upper stage, it is ejected from the first stage and not protected during reentry or recovered.

The two separation joints ensure compliance with the required separation sequence.

Separation and Deceleration System

The Ares first stage booster is recovered and reused as is the present Shuttle RSRM. Recovery reduces system life-cycle costs and facilitates postflight inspection of the expended stage hardware. For a human-rated vehicle, the inspection of flight hardware provides invaluable insight on component margins and system performance in actual flight environments. This valuable feedback data helps maintain a safe, highly reliable product.

There are significant differences between the Ares and the Shuttle flight environments that affect the approach and design of the recovery system. The Ares booster stages at a higher energy state and flies to a much higher apogee. This results in reentry conditions that require changes to the current Shuttle deceleration system. In addition, the Ares first stage booster uses a heavier five-segment motor that requires larger main parachutes to maintain acceptable splashdown velocities. Therefore, a new deceleration system design is necessary for successful booster recovery.

The major components of the deceleration system are depicted in Figure 4. The function of these components is outlined in time-sequenced order in Table 3. The first event that occurs after staging is the initiation of a pitch plane tumble maneuver, which maximizes needed drag during the free-fall part of the reentry trajectory. Without this maneuver, the booster would not reach an acceptable dynamic pressure condition for parachute deployment at the proper altitude allowing complete deceleration before water impact. The tumble is initiated by four booster tumble motors (BTM) that are attached to the frustum.

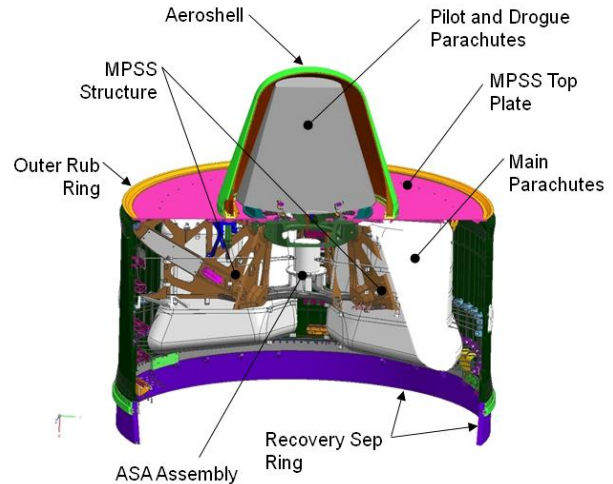

Figure 4. Deceleration and Separation Subsystem Description

Table 3. Post Staging Notational Time Sequence of Events

Key Event	Time (sec)	Altitude (ft)	Velocity (ft/sec)
Separation from Upper Stage	129	194,440	5,898
Tumble Motor Fire	132	203,200	5,850
Frustum/Interstage Separation	142	232,300	5,690
Nozzle Extension Jettison	152	255,800	5,550
Apogee	226	333,270	5,090
Reentry Max Q	372	45,990	3,240
Aeroshell Jettison	398	15,740	595
Pilot chute Deploy	399	15,510	599
Drogue Chute Deploy	400	14,800	590
Drogue Chute Full Disreef	413	9,300	395
Fwd Skirt Extension Separation	429	4,000	309
Main Chutes Deploy	431	3,350	360
Main Chutes Full Disreef	443	900	115
Water Impact	453	0	71

Shortly after the tumble maneuver, the frustum/interstage is separated when the booster has rotated approximately 180 degrees. Separation velocity between the frustum/interstage and booster results from the booster's pitch rotation. After this event, the booster is in a reentry configuration. The booster does not maintain an end-over-end tumble through reentry, but eventually decays into a rocking motion in the pitch plane.

Between 15,000 and 16,000 ft altitude, thrusters jettison the aeroshell upon command from the altitude sensor assembly. The aeroshell protects the pilot and drogue parachutes from the high thermal and dynamic pressure environments

during reentry. The drogue chute stabilizes the booster in a vertical orientation and, through multiple reefing stages, slows the booster to a velocity (about 300 ft per second) low enough for main chute deployment.

The three main parachutes are housed in the FSE. Upon a second signal from the altitude sensor assembly, the FSE separation ring separates the FSE from the forward skirt pulling the main parachutes from the bottom as is presently done on the Shuttle. After several reefing stages, the booster finally impacts the water at approximately 71 ft. per second.

Avionics, Electrical, and TVC Systems

The Ares I avionics and control system provides the means to control first stage powered flight as well as all necessary prelaunch testing and checkouts. The first stage avionics and control system supports all functions from stage initiation through parachute deployment. Critical functions are fault tolerant. During ascent, the first stage will not be required to provide any computing and control functions, but will be required to respond to all validated commands. The majority of the Ares I avionics system components will be housed in the equipment section forward of the solid rocket

motor forward segment. This location will provide a watertight enclosure and protection from all flight environments. The Ares I avionics system will: 1) provide the necessary electrical power for the first stage system (no power will be required by the upper stage), 2) provide flight-critical communication with the upper stage using MIL-STD-1553 data buses, 3) provide a separate communication link with the upper stage for transmitting noncritical engineering data to ground receiving stations, 4) provide data and video storage capacity, which can be downloaded after flights, 5) provide all recovery functions after separation from the upper stage, and 6) provide nozzle steering using the Shuttle legacy TVC system.

The Ares first stage avionics architecture is divided into five subsystem elements: 1) power system, 2) command and control, 3) pyrotechnic control, 4) flight data instrumentation, and 5) TVC. The following section briefly describes each of the five subsystem elements graphically depicted in Figure 5.

Power System. This controls and monitors two sources of power. The first source is provided by ground operation while the Ares I is on the mobile

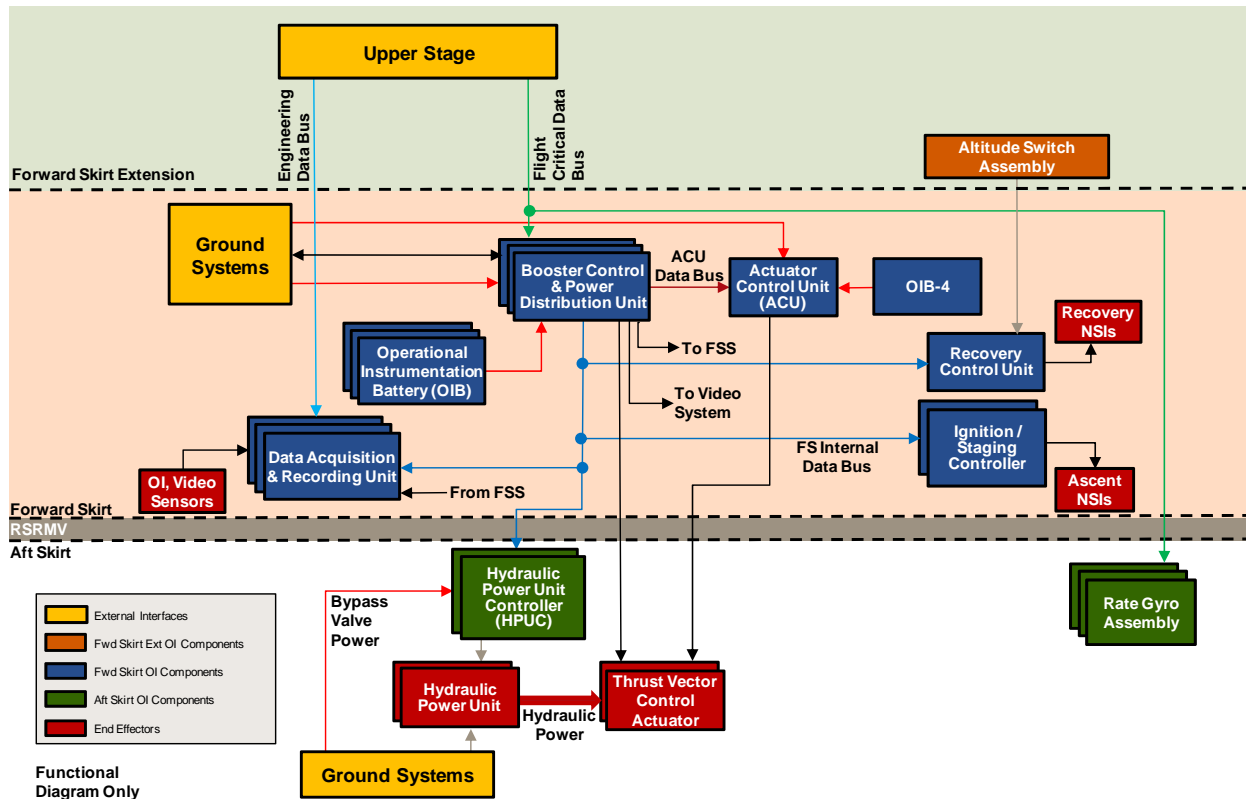

Figure 5. Avionics Architecture

launch platform (MLP). The second source, onboard batteries, provide power for ascent. The power system switches between the ground power supply and the batteries before the launch, conditions the power as required, and monitors the status of the power source. Major elements of the power system are the battery and power distribution unit.

Command and Control. This contains the following three main components:

- Booster Control Unit (BCU) de-multiplexes commands and provides discrete commands to various first stage functions, including the thrust vector actuator, and multiplexes flight-critical data for transmission to the upper stage if required. All upper stage and ground commands come into the BCU.
- Rate Gyro Assembly provides angular rate information of the vehicle to the upper stage via a flight-critical data bus.
- Hydraulic Power Unit Controller (HPUC) controls the use of an auxiliary power unit. The hydraulic power unit monitors the turbine speed through signals received from two magnetic pickup units located in the turbine shaft and controls the fuel flow to the gas generator. Two HPUCs will control the two Shuttle heritage auxiliary power units (APU) and provide the APU out function, which accelerates one turbine should the other fail to operate so first stage flight can be accomplished.

Pyrotechnic Control Unit (PCU). This provides all pyrotechnic event discrete signals including recovery functions, motor firing, hold-down postfiring, separation firing, nozzle exit cone jettison, chute deployments, and aeroshell jettison.

Flight Data Instrumentation (FDI). This consists of the following three main components:

- Data Acquisition Unit (DAU) provides excitation, signal conditioning, and encoding of the operational instrumentation. Each DAU in the FDI subsystem will interface with a noncritical high-speed data bus to provide a subset of monitored data to the Ares I upper stage for downlink. Each DAU will record digital data internally and in the data recording unit (DRU). Each DAU will receive power from one of the operational instrument power distribution units and will be electrically isolated from each other and

from all other electrical equipment except the operational instrument channel from which it draws electrical power.

- DRU – Two DRUs provide onboard data storage from video systems and the DAU for data transmitted to the ground. To avoid bandwidth limitations for ground telemetered data, the DRU will be capable of recording many more channels of engineering data than normally possible. During flight, data will be stored in the DRU and downloaded after recovery of the motor. The DRU will interface via the video/developmental flight instrumentation (DFI) data bus to the DFI master and video controllers and via the first stage internal data bus to the DAUs, BCUs, PCUs, and HPUCs.
- DFI will fly on the first few missions to collect and monitor the performance of the Ares first stage.

TVC. The TVC provides pitch and yaw control during ascent. Roll control is an upper stage function. The TVC system is located in the solid rocket booster (SRB) aft skirt and consists of two separate hydraulic power units that supply hydraulic power to the heritage TVC electro-hydraulic servo-actuators to effect mechanical positioning of the nozzle in response to steering commands.

Ordnance and RSS

Ares first stage pyrotechnic devices are required to support motor functions such as motor ignition, separation, and motor case recovery sequences. Other pyrotechnic and avionics devices are necessary for range safety.

The top-level design requirements for pyrotechnics include: 1) reliability, 2) fault tolerance, and 3) flight separation. These requirements are allocated to component specifications that require testing, redundancy, and specific functionality to verify upper-level requirements.

There are ten pyrotechnic events identified for the first stage. These events are tabulated in Table 4 and mapped in Figure 6.

These ten events will consist of common pyrotechnic components or building blocks arranged in a pyrotechnic train. These building blocks are detonators, manifolds, explosive transfer lines (ETL), separation systems, and initiators.

Table 4. Pyrotechnic Events

- | | |
|--|---------------------------|
| 1. First Stage Motor Ignition | 6. Aeroshell Jettison |
| 2. First Stage/Upper Stage Separation Initiation | 7. Forward Skirt Release |
| 3. BDM Initiation | 8. Parachute Pyrotechnics |
| 4. BTM Initiation | 9. Nozzle Severance |
| 5. Frustum Release | |



Figure 6. Ares I Pyrotechnic Events

The RSS flight termination system (FTS) requirements are allocated from specific system requirements and AFSPCMAN 91-710, as tailored for Ares. The architecture for the first stage FTS is shown in Figure 7.

Aft Skirt

The aft skirt provides structural support for the Ares first stage on the launch pad. The skirt

utilizes spherical attach points to the MLP to transfer natural and induced loads from the vehicle through the aft skirt to the MLP. For liftoff and flight, the aft skirt provides aerodynamic protection, thermal protection, and mounting provisions for the TVC subsystem (Figure 8). The aft skirt is also reusable and must survive water impact loads in addition to the harsh saltwater and sea state environments. The aft skirt has a conical

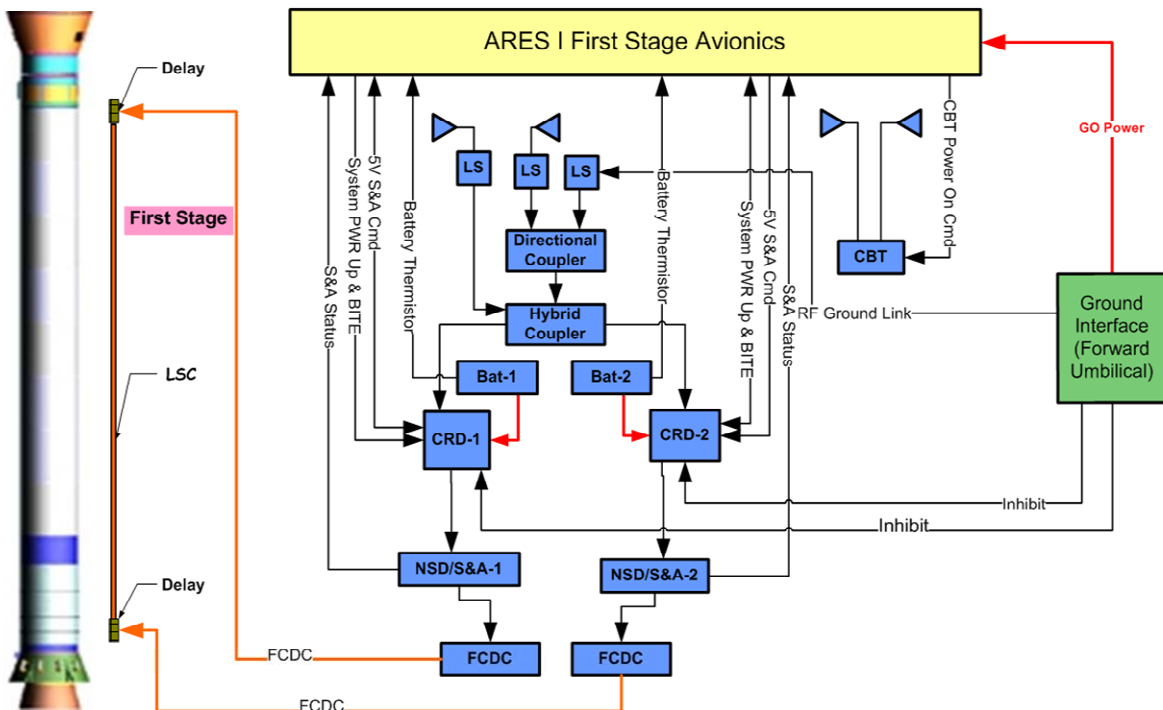

Figure 7. Flight Termination System

shape with a 146-in. minor diameter, a 208.2-in. major diameter, and is 90.5-in. long. This shape accommodates attachment to the aft dome attach tang of the RSRMV and provides sufficient clearance for the nozzle at full gimbaled travel of the TVC system. The aft skirt has an integral stringer/skin construction welded to four forged hold-down posts with bolted-in circumferential rings fabricated from 2219 aluminum. Internal gussets and clips have been added to stiffen the structure and minimize water impact damage. The aft skirt kick ring provides the necessary structural clevis attach points to the RSRMV, which bolts to the aluminum aft skirt and is machined from a rolled ring forging of D6AC steel. Thermal curtains are mounted between the aft skirt and the RSRMV nozzle for thermal protection of the interior aft skirt structure and TVC system components. A liftoff umbilical for electrical functions and power and the heated gaseous nitrogen purge probe are located on the aft skirt aft circumferential ring web and mate with the MLP (Figure 8).

The aft skirt will be modified from the Space Shuttle to the Ares I first stage configuration by removing the aft booster separation motors (BSM) and plugging the attach holes, designing an avionics support structure to attach the APU speed controller boxes, making accommodations for increased capacity for the T-0 umbilical up the systems tunnel, designing new thermal curtain replacements, and designing additional external thermal protection material for the structure. On-pad Ares wind loads are critical and can exceed Shuttle main engine startup loads for the aft skirt requiring a significant structural beef-up and/or the

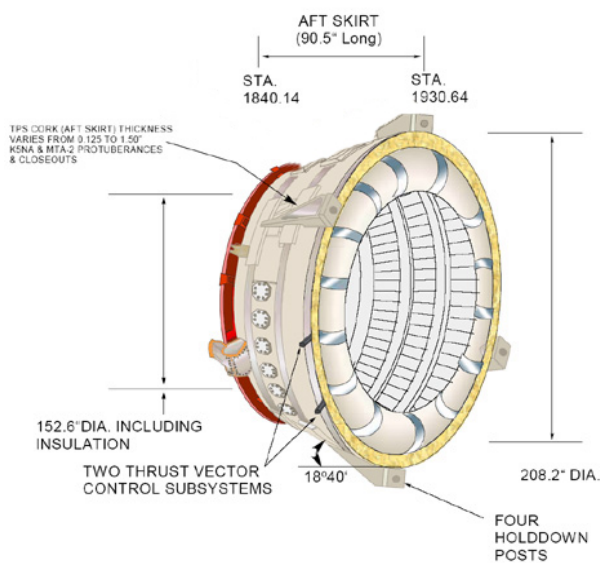

Figure 8. Aft Skirt Assembly

addition of an on-pad vehicle damper/support structure.

SYSTEMS ENGINEERING METHODOLOGY

This section discusses the systems engineering methodology used in designing and developing the Ares I first stage.

Requirements Generation

There are various sources for the technical requirements applicable to the first stage as shown in Figure 9. Defining technical requirements required converting needs, goals, and objectives to technical requirements in order to capture constraints and conduct requirements analysis and traceability.

The first step in the process was to evaluate SRB and RSRM requirements (heritage documents) for applicability to the Ares first stage design. This step included eliminating requirements specific to the Shuttle, modifying wording to be specific to the first stage, and evaluating the technical rationale for the requirement. The second step involved adding allocated requirements from the Ares System Requirements Document (SRD).

Requirements Allocation

System requirements and control are implemented from the top down and products are realized and verified from the bottom up. Requirements are allocated to each subsystem. Each subsystem program manager and chief engineer reviewed requirements for applicability to their subsystem.

Requirements Management

Requirements are developed and managed using a systems engineering software called Teamcenter Systems Engineering (TcSE).

ATK's Ares TcSE is a user interface to a database that holds and maintains requirement objects, their properties, and the relationship between objects. The interface is similar to a Windows Explorer window with a pane for viewing the hierarchy of the folders and a content pane for viewing the objects within the folders. The interface also provides the means for viewing additional data about each object in the forms of properties, attachments, linkages, etc.

TcSE is an object-oriented database, which means that each requirement is contained within a separate object in TcSE. Each object can be opened with Microsoft Word directly from the database and edited as needed. Saving the Word file automatically updates the database with the new data. Each object is a standalone object in

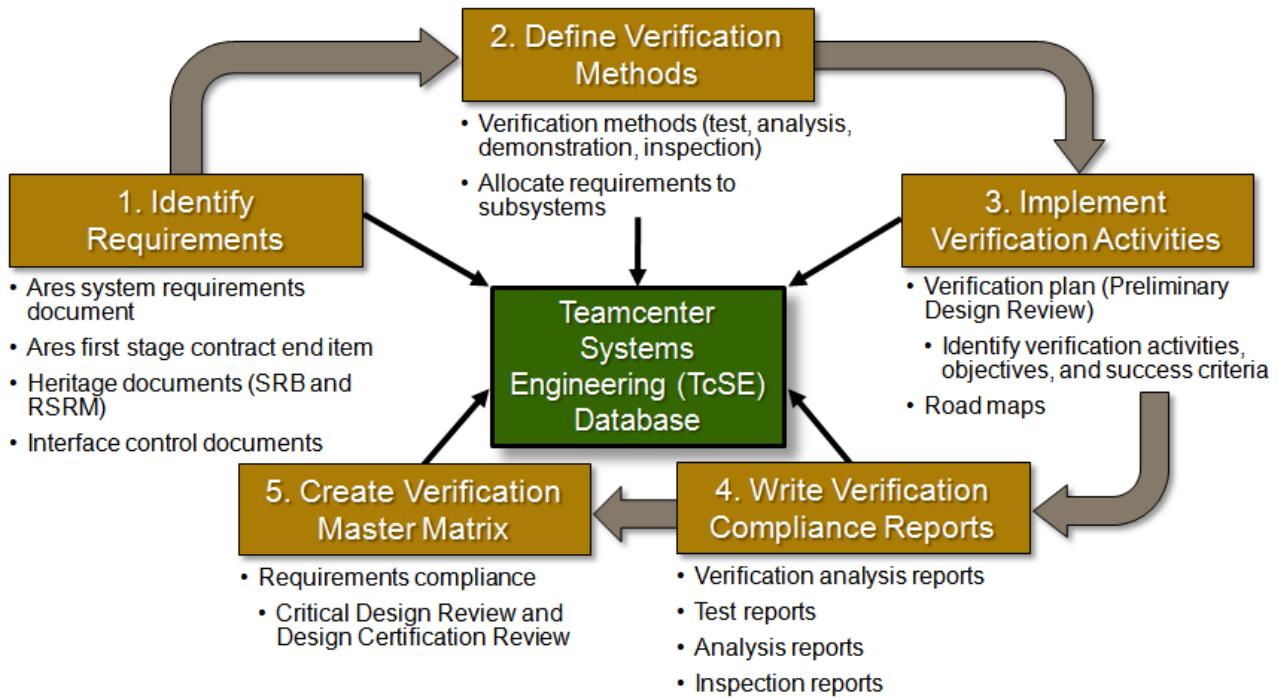

Figure 9. First Stage Requirements and Verification Process

the sense that you can add specific detail and information to the object that does not necessarily apply any other objects. For example, a property might be given a value describing the group responsible to verify that requirement, or a note containing the requirement's rationale might be added, or traceability links might be made to the parent and/or children requirements. Each requirement and its associated information are maintained separately but requirement objects are grouped to form specifications and verification plans and the relationships between the objects are used to provide traceability matrices and compliance reports.

Verification and Validation Approach

A detailed verification and validation approach ensures that the Ares I first stage complies with design, performance, and safety requirements and can be successfully integrated with the Ares I upper stage. The general verification approach includes the following:

- Design, development, and qualification phases that lead to a certified design
- Acceptance, preflight, and assembly checkout, integrated testing, flight, and postflight phases, which verify each Ares I first stage element complies with the design requirements, applicable verification methods of similarity, analysis, inspection, demonstration, and test

- Facilities and ground support equipment checkouts
- Ground motor tests, ascent development flight tests, and development flight tests

The environmental test requirements, test methods, and test criteria established in the first stage critical end item specification will be used as guides during testing and verification of the vehicle's avionic, mechanical, hydraulic, and other components, excluding major structural components.

Verification Plans

Verification plans are written for each Ares first stage subsystem. Each verification plan addresses the applicable requirements of the critical end item as well as the applicable subsystem specification.

The verification plan includes preliminary summaries of each task required for complete verification of the Ares first stage material, component, assembly, part, or manufacturing processes. The similarity, analysis, and inspection summaries serve as the plan for that activity. Test and demonstration summaries are preliminary test planning summaries, which lead to NASA approved test plans. Verification reports are prepared addressing each of the completed verification activities specified in the verification plan.

Detailed Verification Objectives

The verification plan includes verification task summary sheets to outline the detailed verification objectives (DVO) that will define the strategy for showing compliance to the contract end item requirements for the specific task summary sheet. The DVOs will feed into the test plans, analysis, and inspection verification activities. All summary sheets are tied to an integrated logic flow and master schedule. The logic flow and schedule are discussed later in this paper.

Verification Traceability and Compliance Document

TcSE is used to show requirements traceability from the Ares SRD to the first stage contract end item specification down to the subsystem level system requirements documents. A master matrix document will be created from TcSE that will provide the compliance traceability to all first stage system requirements documents. It will be a living document that will provide a history of the baseline certification and will be updated to include compliance to all requalification efforts thereafter.

SYSTEM SAFETY TOOLS

Nothing is more important during a design, development, test, and evaluation phase of a program than identifying and eliminating or reducing risk associated with hardware and system performance. The ATK Ares I first stage utilizes system safety and reliability (SS&R) and associated risk tools to enhance the design for improved safety and increased reliability. Collectively, the tools described below provide rigorous SS&R processes and analyses input to the design early in the program, which reduces future change costs and in turn ensures safe and reliable performance of the Ares I first stage flight program.

Fault Tree

The Ares I first stage fault tree is a logic diagram showing the cause and effect relationship between a top-level undesired event (loss of life during pre-launch and launch) and one or more contributing causes. It is developed through a top-down approach, which includes all related subevents, including external events with other elements. The fault tree identifies single and/or combinations of failures that can result in hazards. Each identified hazard on the fault tree results in the

documentation of a stand-alone hazard analysis. Thoroughness and accuracy of the fault tree is vital, as the results provide key ingredients in preparing the hazard analysis and the probabilistic risk assessment Analysis (PRA). Understanding and communicating these single and/or combinations of failures to the Ares team allows early impact to the system design and manufacturing processes.

Hazard Analysis

Hazard analysis takes the hazard, depicted from the fault tree, and puts it into a predetermined format in which the system safety engineer can begin to analyze and populate various data fields. The hazard analysis identifies design and operational controls to mitigate the risk level of the hazardous condition. ATK's primary objectives during this design, development, test, and evaluation period is to either eliminate the hazard through design or impact the design to minimize the hazard (design for minimum risk) through selecting appropriate design features such as fail-operational/fail-safe combinations (fault tolerant designs) and appropriate safety factors. Damage control, containment, and isolation of potential hazards are also included in design considerations. Coordinating this hazard analysis activity early with ATK's Systems and Integration and Quality Engineering teams allows for early design changes to be considered for the first stage and any other affected elements, resulting in eliminated, reduced, or accepted risk designs for the first stage and Constellation program.

Reliability Tools

Failure modes and effects analysis (FMEA) provides a systematic identification of component failure modes for evaluation as well as identification of potentially critical single failure points for possible elimination. This systematic identification technique is more of a bottoms-up approach when analyzing the intended design function of each first stage component as opposed to the fault tree and hazard analysis top-down approach, which provides more of a system-level analysis. The FMEA provides a preliminary assessment of the first stage's design compliance with program reliability requirements. The FMEA identifies specific component failure modes, failure causes, and failure effects, with assigned criticality levels for each defined mission phase.

PROGRAM PLANNING AND EXECUTION

Ares first stage program planning was a sequential process, which is depicted in Figure 10.

Contractor Work Breakdown Structure

The NASA-provided Ares first stage statement of work (SOW) was decomposed to create a product-based contractor work breakdown structure (CWBS). The CWBS defines the project and groups the project's discrete work elements in a way that organizes and defines the total scope of the project. A CWBS element may be a product, data, service, or any combination. The CWBS also provides the necessary framework for detailed cost estimate and control along with guidance for schedule development and control. Additionally, the CWBS is a dynamic tool and can be revised and updated as needed by the Ares I first stage project manager.

CWBS Dictionary

For each element of the CWBS, a description of the task to be performed was generated. These descriptions were compiled to create a CWBS dictionary. The dictionary reflects a detailed decomposition of the NASA provided SOW.

Integrated Master Plan

Next, an integrated master plan (IMP) was created. In simple terms, the IMP is an indented listing of major program events, significant

accomplishments, and accomplishment criteria. Major program events consist of the traditional program milestones (SRR, PDR, CDR, DCR, etc.), significant ground and flight tests, key hardware deliveries to NASA, etc.

Integrated Logic Flow

The integrated logic flow (ILF) identifies all deliverables, tasks, and data associated with major program events. This includes verification summary sheets previously mentioned in the verification planning discussion. The ILF contains fourteen swim lanes. Each swim lane represents a key branch of the CWBS. Figure 11 outlines the logic flow approach. Interactions (inputs and outputs) between the swim lanes are also shown. The ILF is key to building the program logic and thus creating and adhering to the schedule.

SUMMARY

We are fortunate to have an exciting and challenging mandate to leave low earth orbit, return to the moon, and travel to Mars. A key element in accomplishing this mandate within the timeframe and fiscal realities set forth by the President and NASA administrator is the utilization of existing hardware and technologies wherever possible and practical. Success is predicated upon strong system engineering processes and detailed program planning.

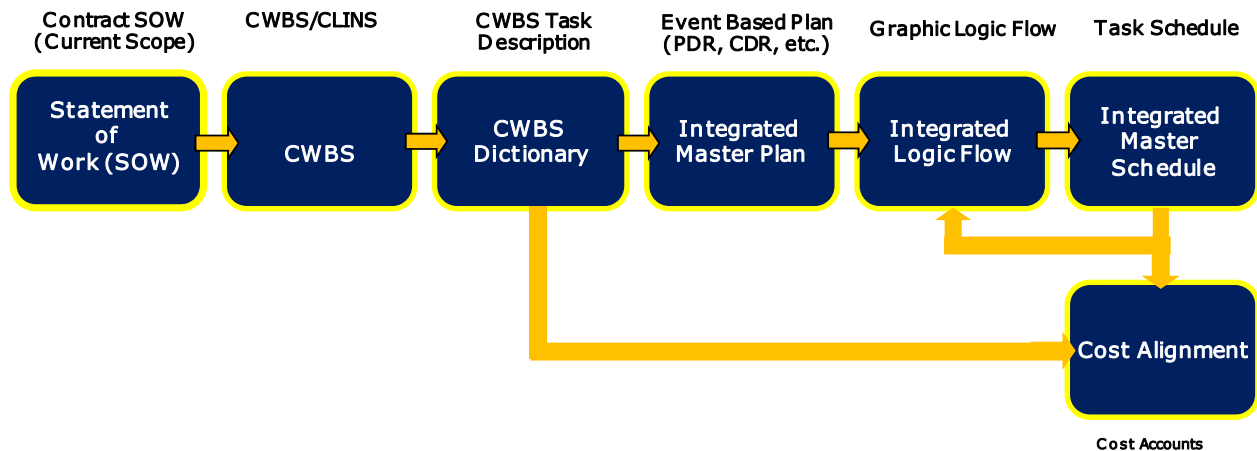

Figure 10. Program Planning Process

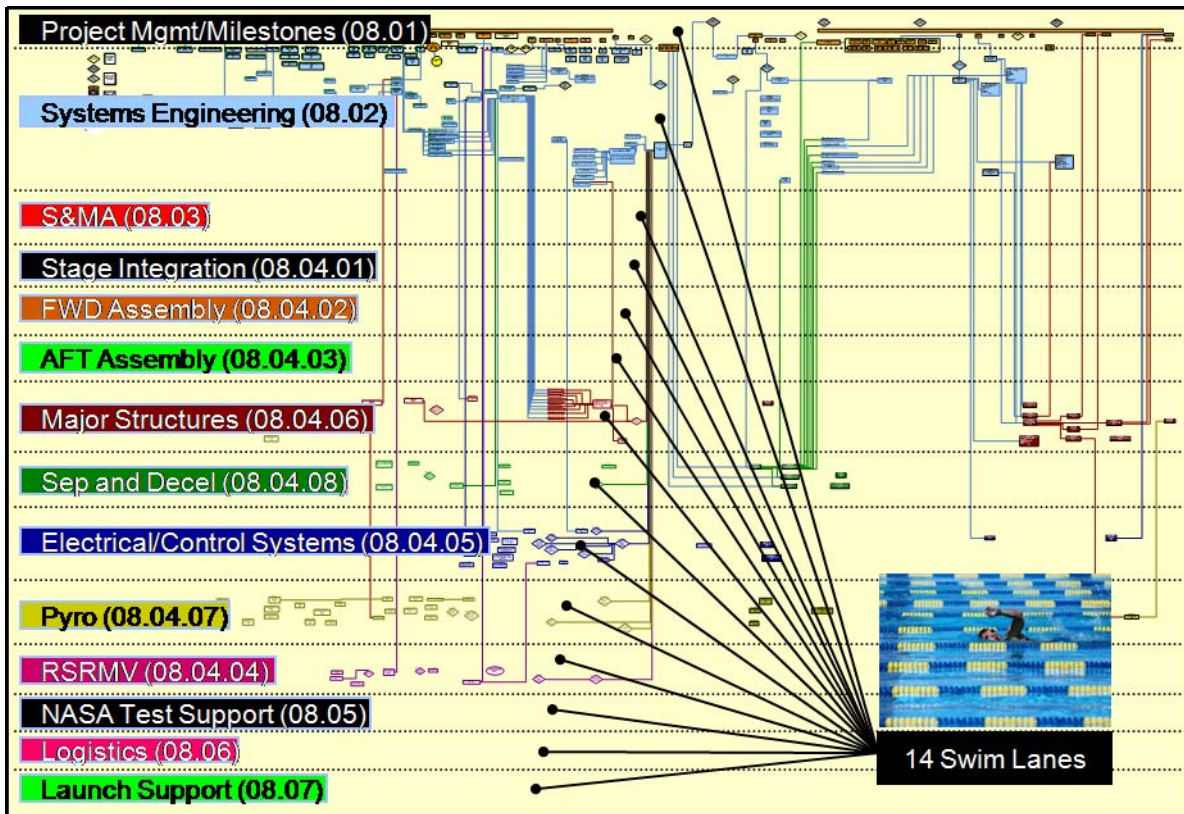

Figure 11. Integrated Logic Flow

ACRONYMS/GLOSSARY

AP.....	ammonium perchlorate	IMP.....	integrated master plan
APU.....	auxiliary power unit	MLP.....	mobile launch platform
BCU.....	booster control unit	MPSS.....	main parachute support structure
BSM.....	booster separation motor	NASA.....	National Aeronautics and Space Administration
BTM.....	booster tumble motor	PCU.....	pyrotechnic control unit
CDR.....	critical design review	PDR.....	preliminary design review
CWBS.....	contractor work breakdown structure	RSRM.....	reusable solid rocket motor
DAU.....	data acquisition unit	RSRMV ..	five-segment reusable solid rocket motor
DCR.....	design certification review	RSS.....	range safety system
DFI.....	developmental flight instrumentation	S&A.....	safe and arm device
DRU.....	data recording unit	SOW.....	statement of work
DVO.....	detailed verification objectives	SRB.....	solid rocket booster
ETM.....	engineering test motor	SRD.....	system requirements document
FDI.....	flight data instrumentation	SRR.....	system requirements review
Fe ₂ O ₃	ferric oxide	SS&R.....	system safety and reliability
FMEA.....	failure modes and effects analysis	TcSE.....	Teamcenter Systems Engineering
FSE.....	forward skirt extension	TVC.....	thrust vector control
FTS.....	flight termination system		
HPUC.....	hydraulic power unit controller		
ILF.....	integrated logic flow		

59th International Astronautical Congress
29 September – 3 October 2008, SECC, Glasgow, Scotland

Ares First Stage "Systemology" — Combining Advanced Systems Engineering and Planning Tools to Ensure Mission Success

James Seiler

Ares I First Stage System Engineering Program Manager, ATK

Fred Brasfield

Ares I First Stage Program Manager, ATK

Scott Cannon

Ares I First Stage Chief Engineer, ATK

Innovation ... Delivered.



- Ares I is an integral part of NASA's Constellation architecture
- Ares I first stage is an evolution of the extremely successful Space Shuttle reusable solid rocket motor (RSRM) and solid rocket booster (SRB)
- Agenda
 - First Stage Design Summary
 - Requirements Generation Process
 - First Stage "Systemology"



Ares I First Stage Conceptual Design



Innovation ... Delivered.

Performance Drivers

- 56,200-lbm payload to orbit
- 800-psf maximum dynamic pressure
- 3.8-g maximum acceleration
- Maximize use of “heritage” hardware from Space Shuttle

Major Subsystems Include...

- Five-segment RSRM (RSRMV) derived from heritage four-segment RSRM
- Forward structures assembly
- Separation and deceleration system
- Avionics and electrical system
- Ordnance and range safety systems
- Aft skirt/thrust vector control system

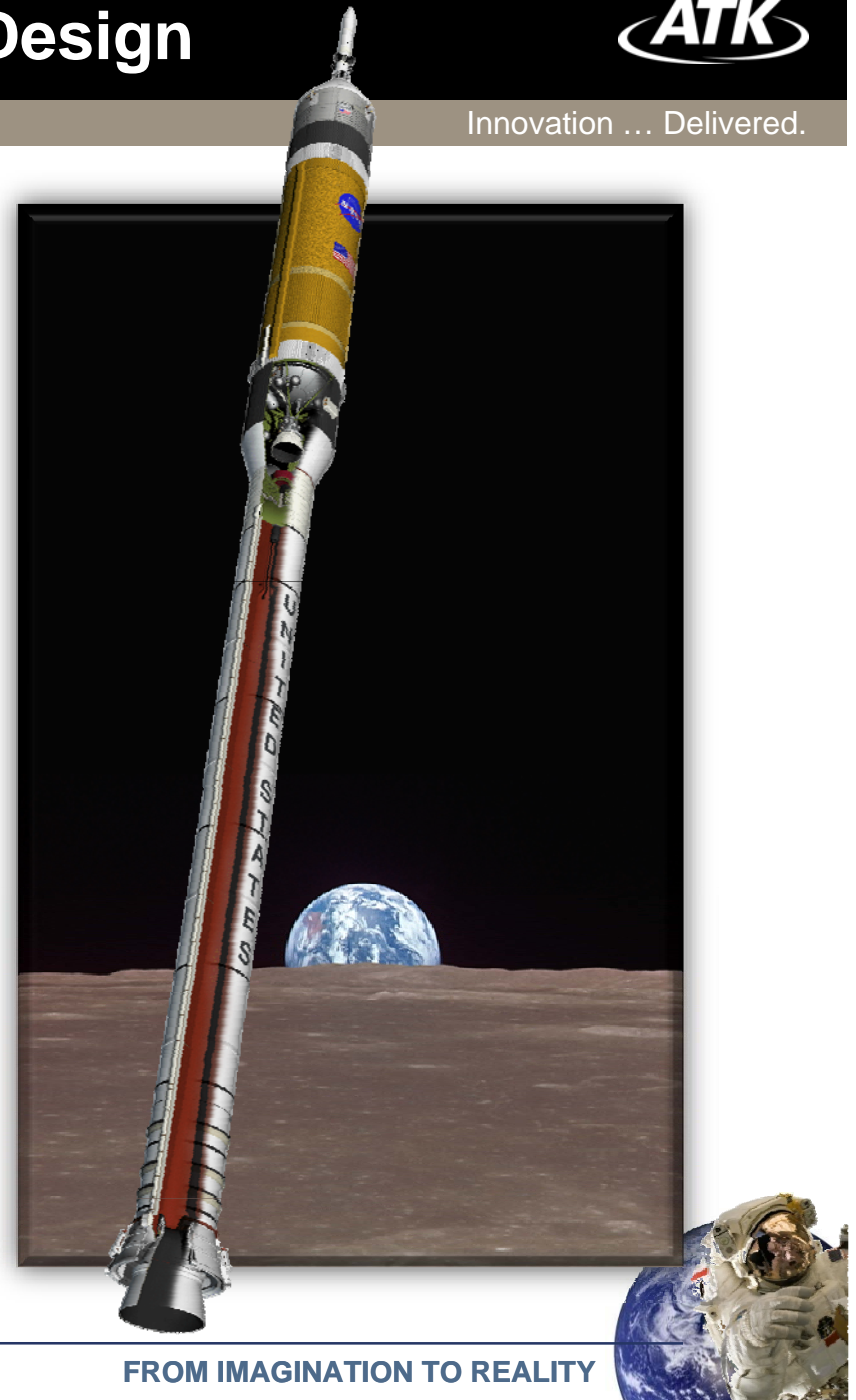

RSRMV Design Change Summary



Innovation ... Delivered.

- The RSRMV design is based on the Space Shuttle RSRM
- Modifications to the motor were made to:
 - Improve performance (thrust)
 - Eliminate hazardous materials
 - Replace obsolete materials

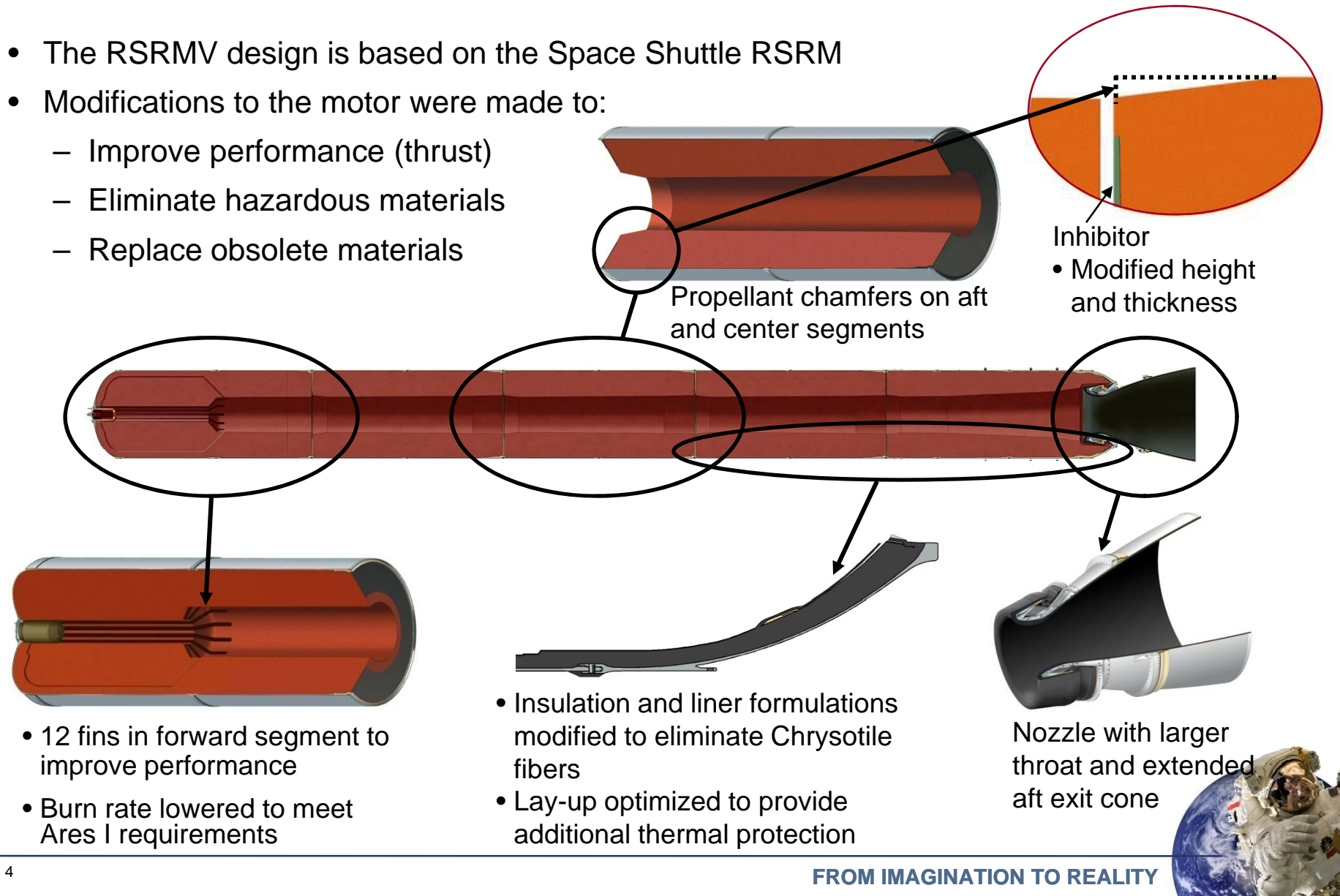

RSRMV vs. RSRM Performance



Innovation ... Delivered.

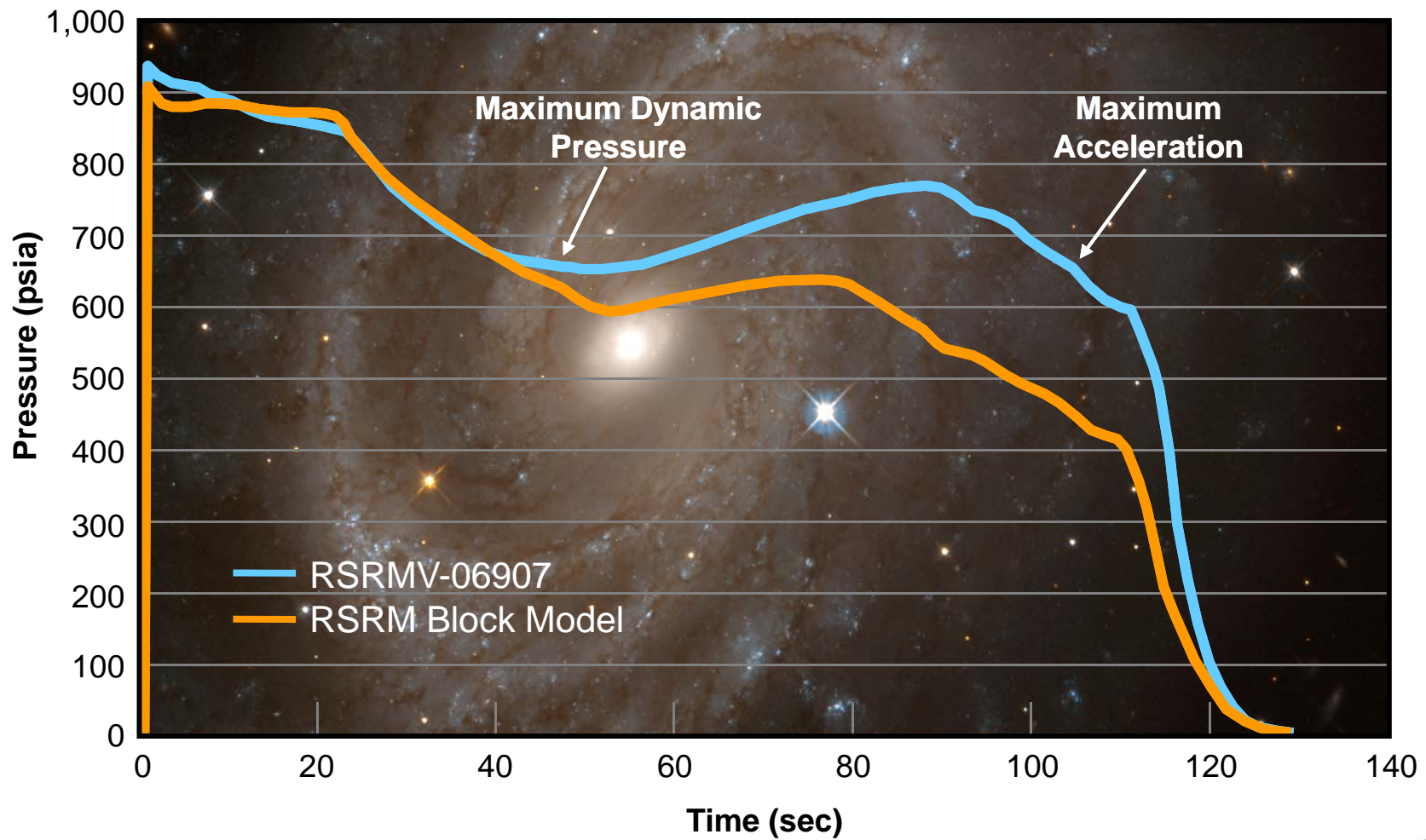

Forward Structures Assembly



Innovation ... Delivered.

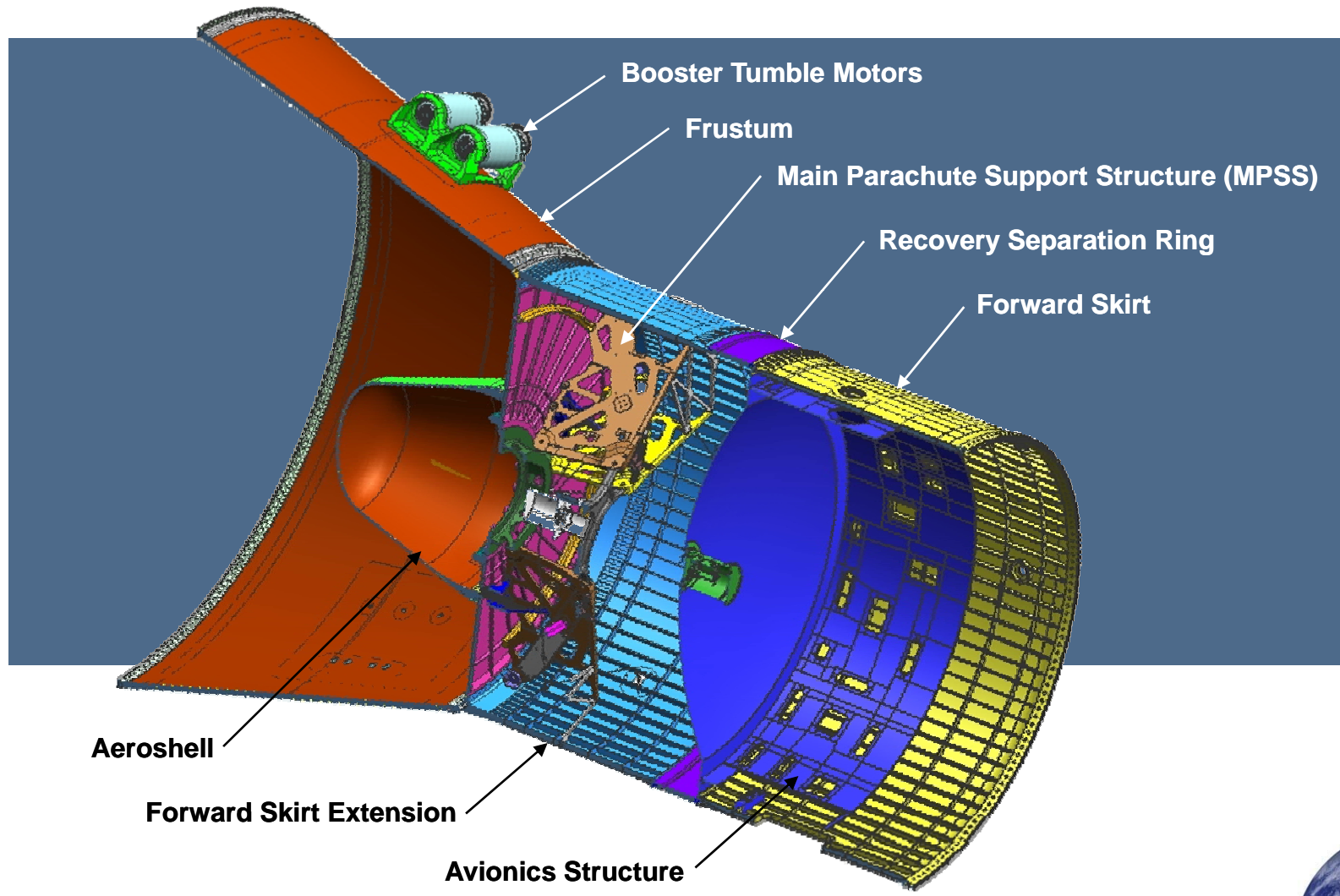

Separation and Deceleration System



Innovation ... Delivered.

Key Event	Time (sec)	Altitude (ft)	Velocity (ft/sec)
Separation From Upper Stage	129	194,440	5,898
Tumble Motor Fire	132	203,200	5,850
Frustum/Interstage Separation	142	232,300	5,690
Nozzle Extension Jettison	152	255,800	5,550
Apogee	226	333,270	5,090
Re-entry Max Q	372	45,990	3,240
Aeroshell Jettison	398	15,740	595
Pilot Chute Deploy	399	15,510	599
Drogue Chute Deploy	400	14,800	590
Drogue Chute Full Disreef	413	9,300	395
Fwd Skirt Extension Separation	429	4,000	309
Main Chutes Deploy	431	3,350	360
Main Chutes Full Disreef	443	900	115
Water Impact	453	0	71

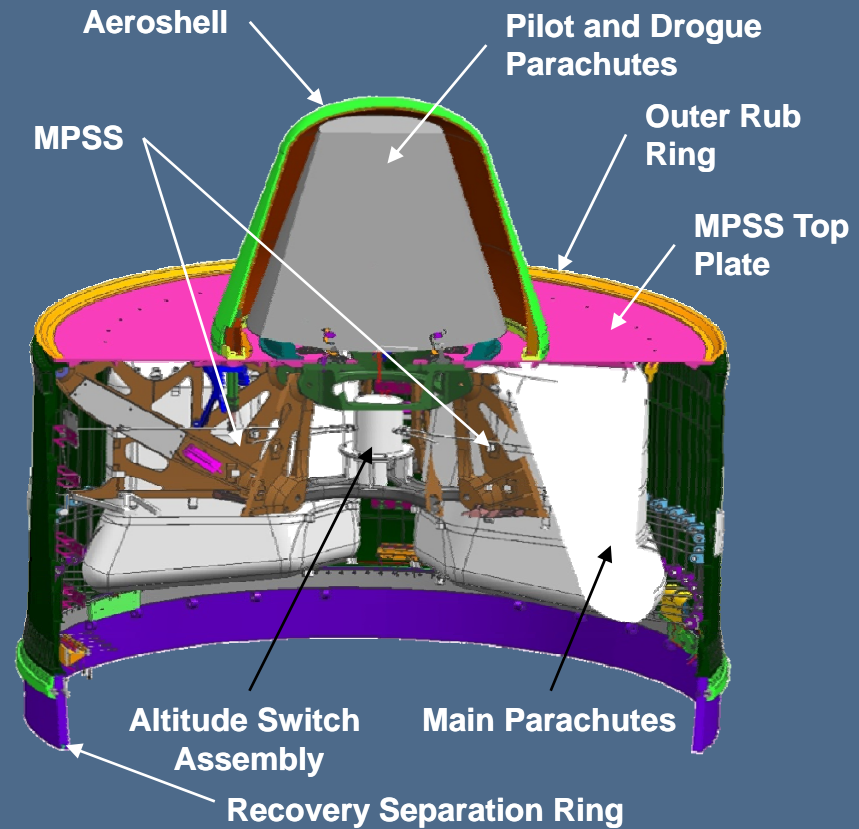

Avionics and Electrical System



Innovation ... Delivered.

Flight critical data communicated over a MIL-STD-1553 data bus

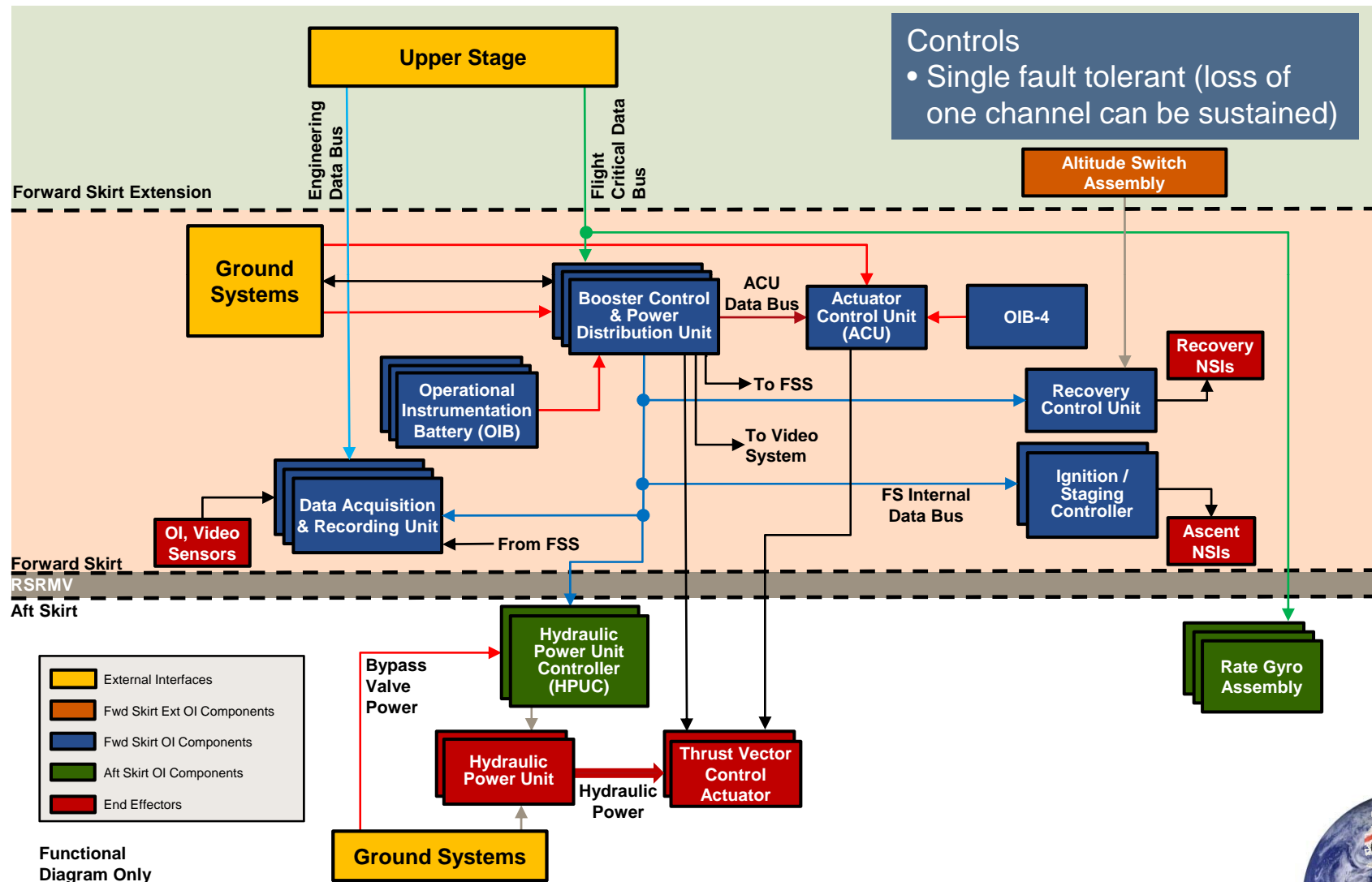

Aft Skirt and Thrust Vector Control System



Innovation ... Delivered.

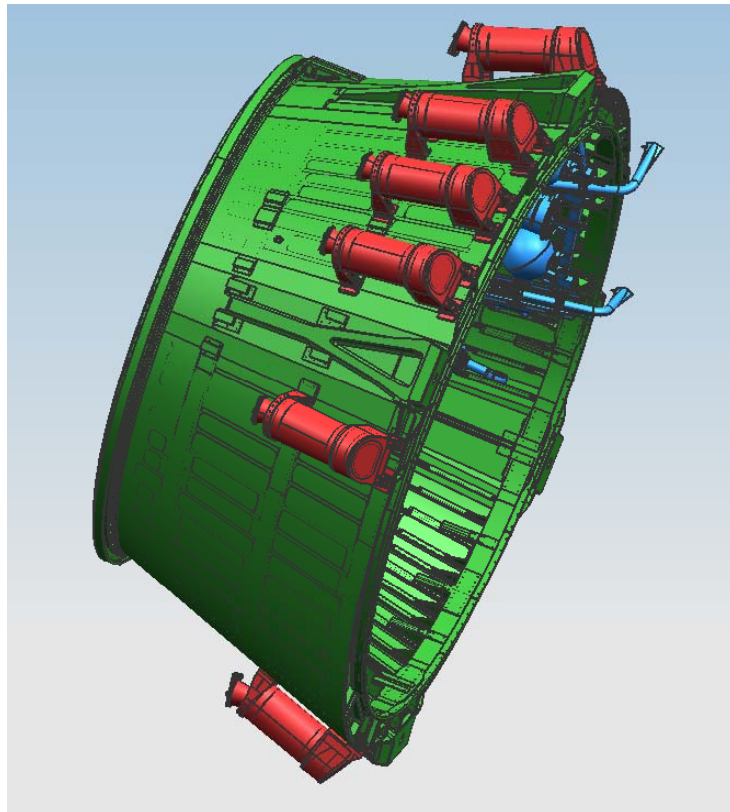

Aft Skirt With Booster
Deceleration Motors

Thrust Vector Control
Components

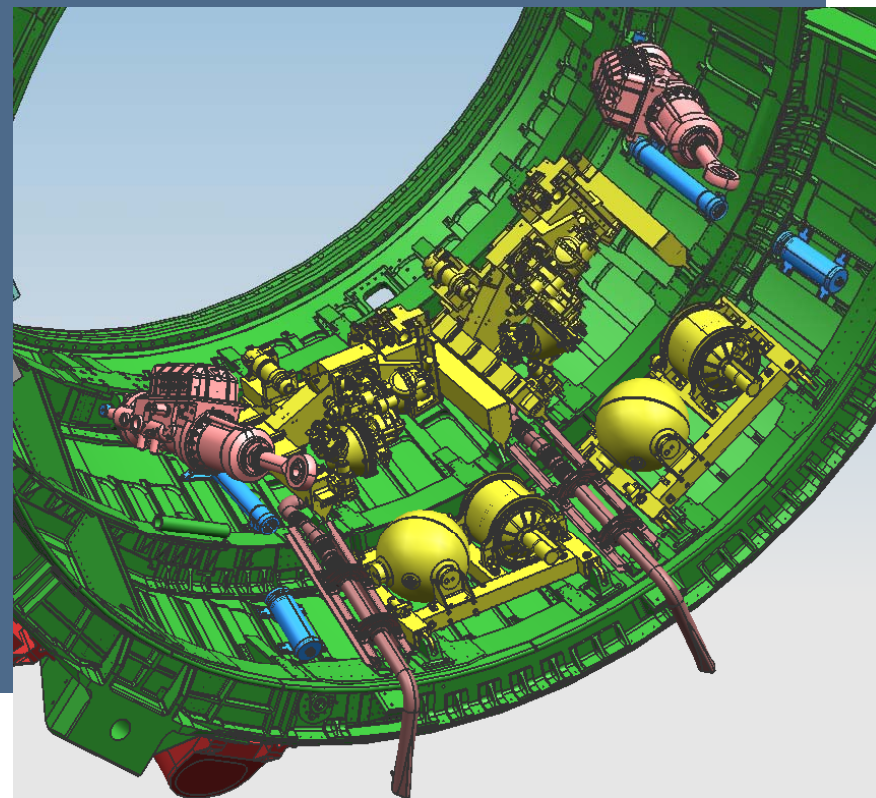

Pyrotechnic Events



Innovation ... Delivered.

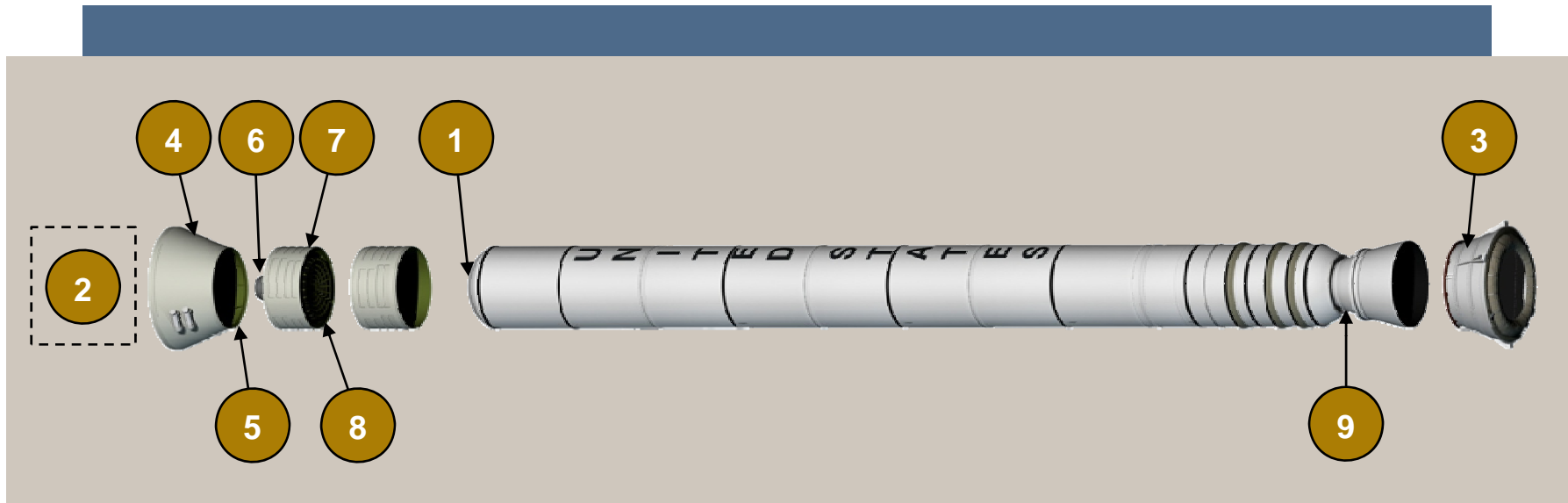

1. First Stage Motor Ignition
2. First Stage/Upper Stage Separation Initiation
3. Booster Deceleration Motor Initiation
4. Booster Tumble Motor Initiation
5. Frustum Release
6. Aeroshell Jettison
7. Forward Skirt Release
8. Parachute Pyrotechnics
9. Nozzle Severance



Requirements Generation Process



Innovation ... Delivered.

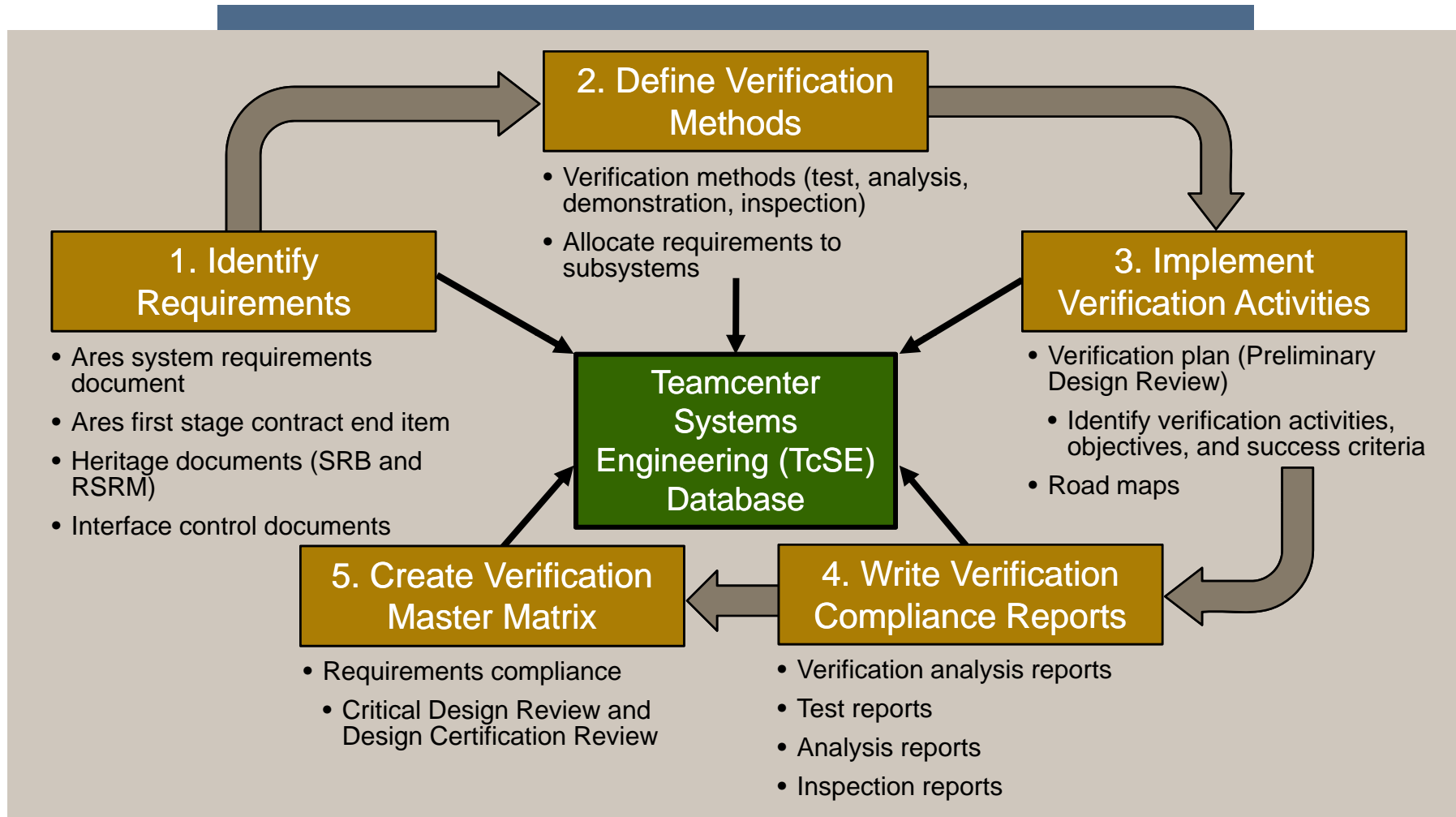

Ares I requirements are a careful balance of “heritage,” performance, and new requirements



Specification Tree — Requirements Allocation



Innovation ... Delivered.

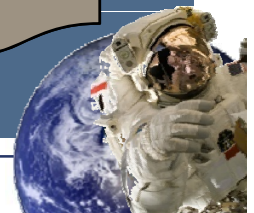
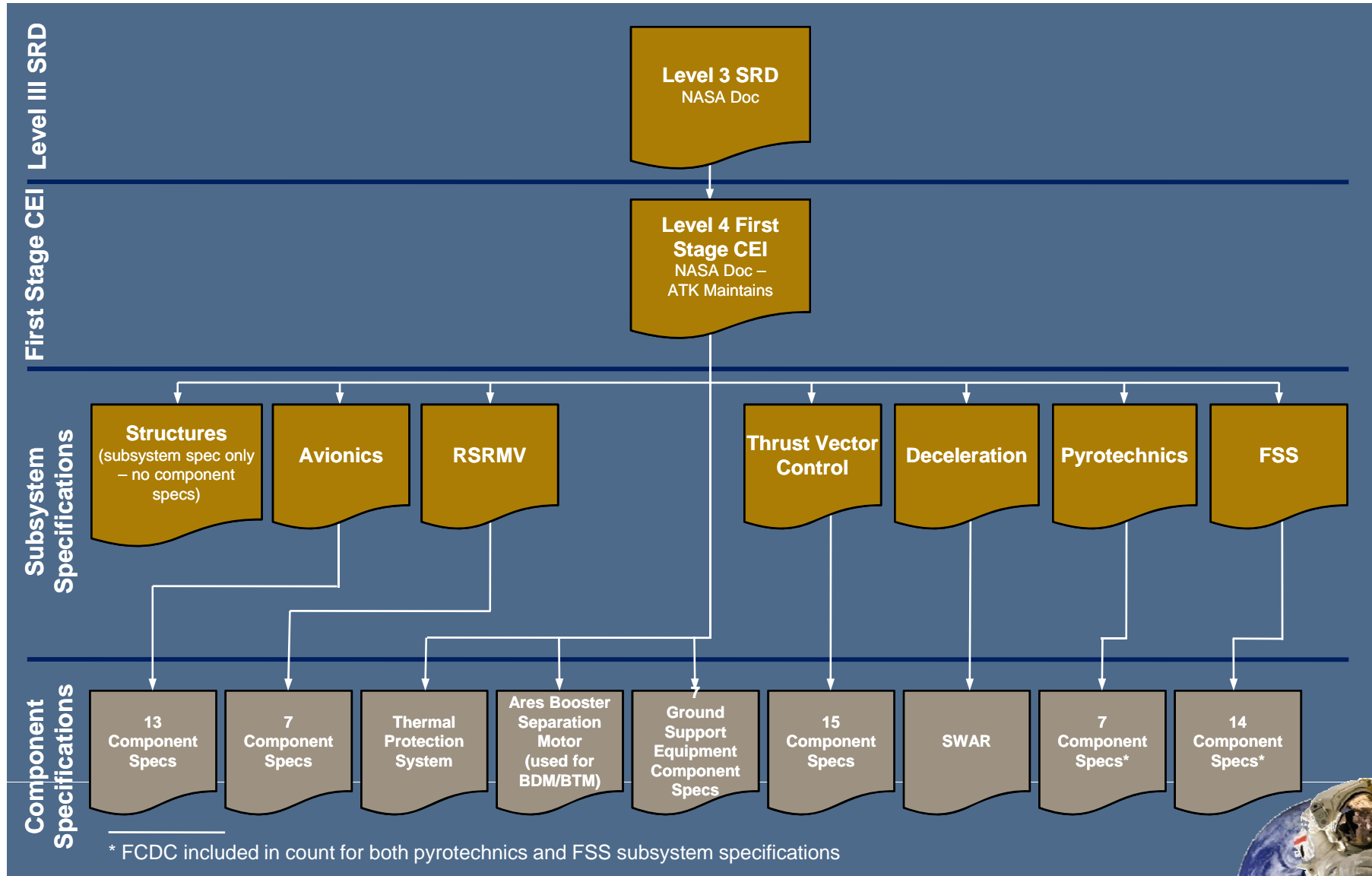

Requirements Allocation Process



Innovation ... Delivered.

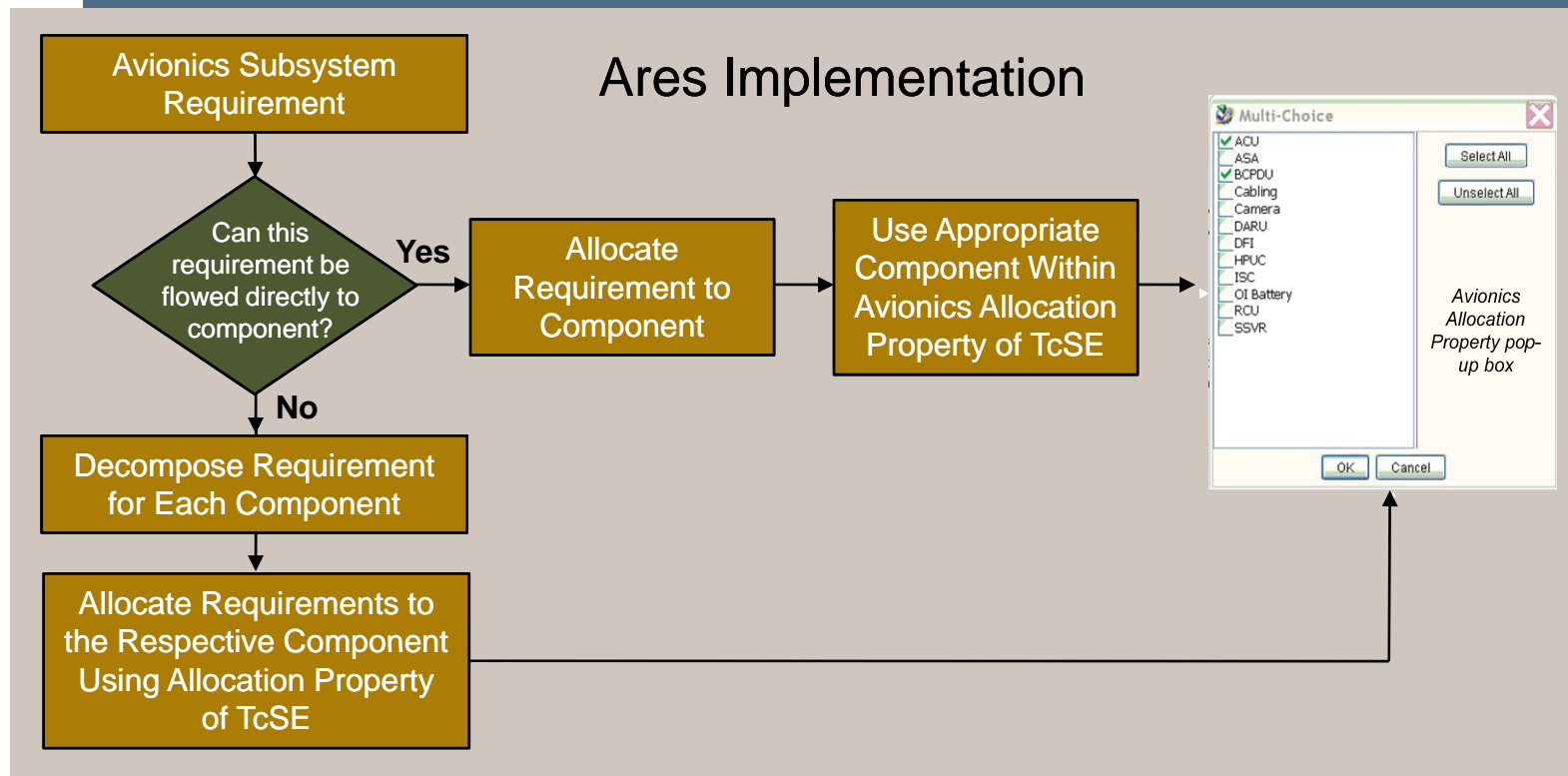
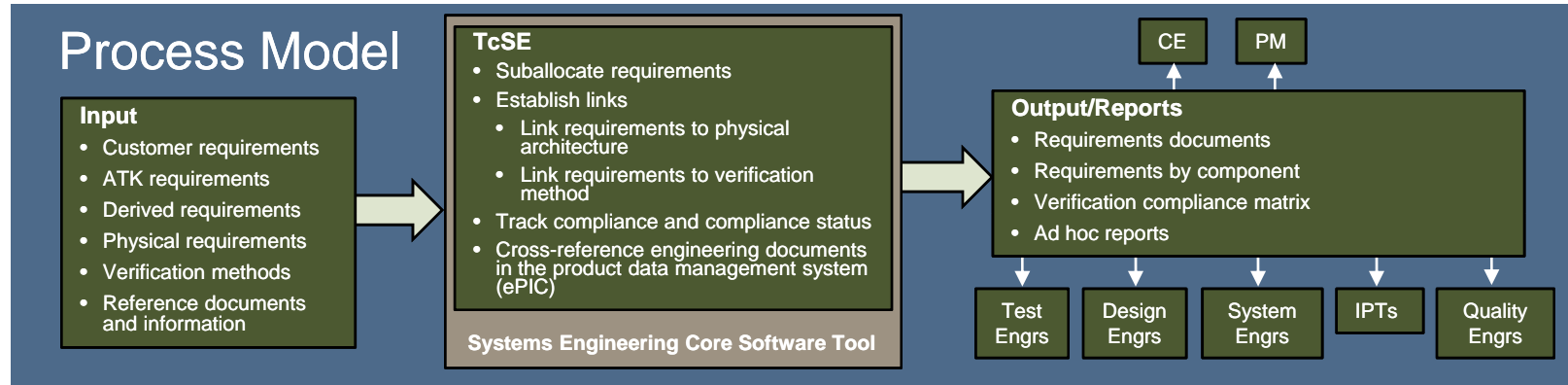

Verification Process



Innovation ... Delivered.

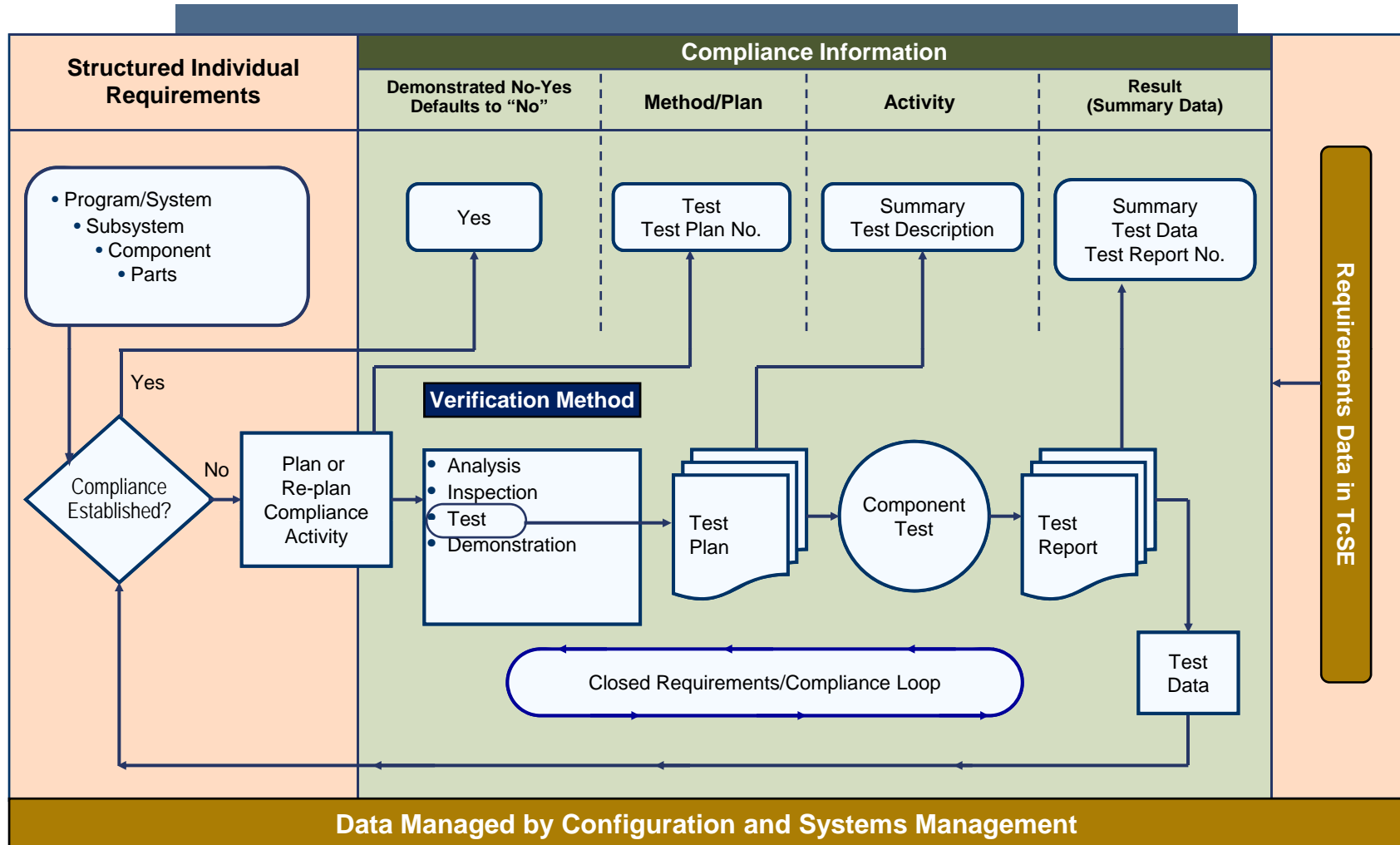

Rigorous Tracking and Closure of Requirement Verification Activities



EVMS Development Process Systematic Approach



Innovation ... Delivered.

- Earned Value Management System (EVMS)
 - Align, link, and trace information across project
 - Cost/schedule/technical performance

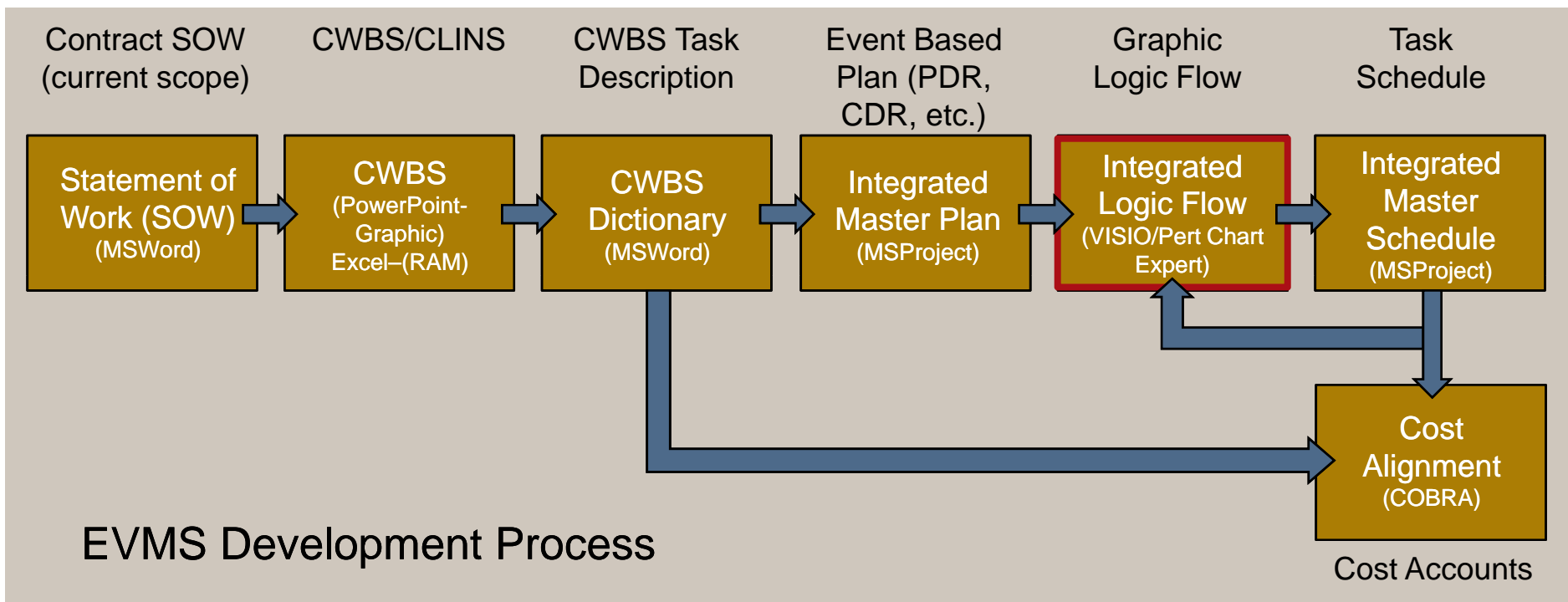

- As an integral part of the overall EVMS enhancement project, Ares I first stage utilizes an integrated logic flow tool to support integrated master scheduling development



Integrated Logic Flow (ILF)



Innovation ... Delivered.

- ILF includes all work associated with requirements compliance
 - Identifies all testing, demonstrations, analyses, and inspections
- ILF is an excellent integration tool
 - Identifies interactions between work packages defined in the work breakdown structure
 - Tasks defined and integrated by technical experts
 - Identifies predecessors and successors
 - Identifies deliverables from and to customer
- Engineering product completion in-sync with major program milestones (reviews, hardware)

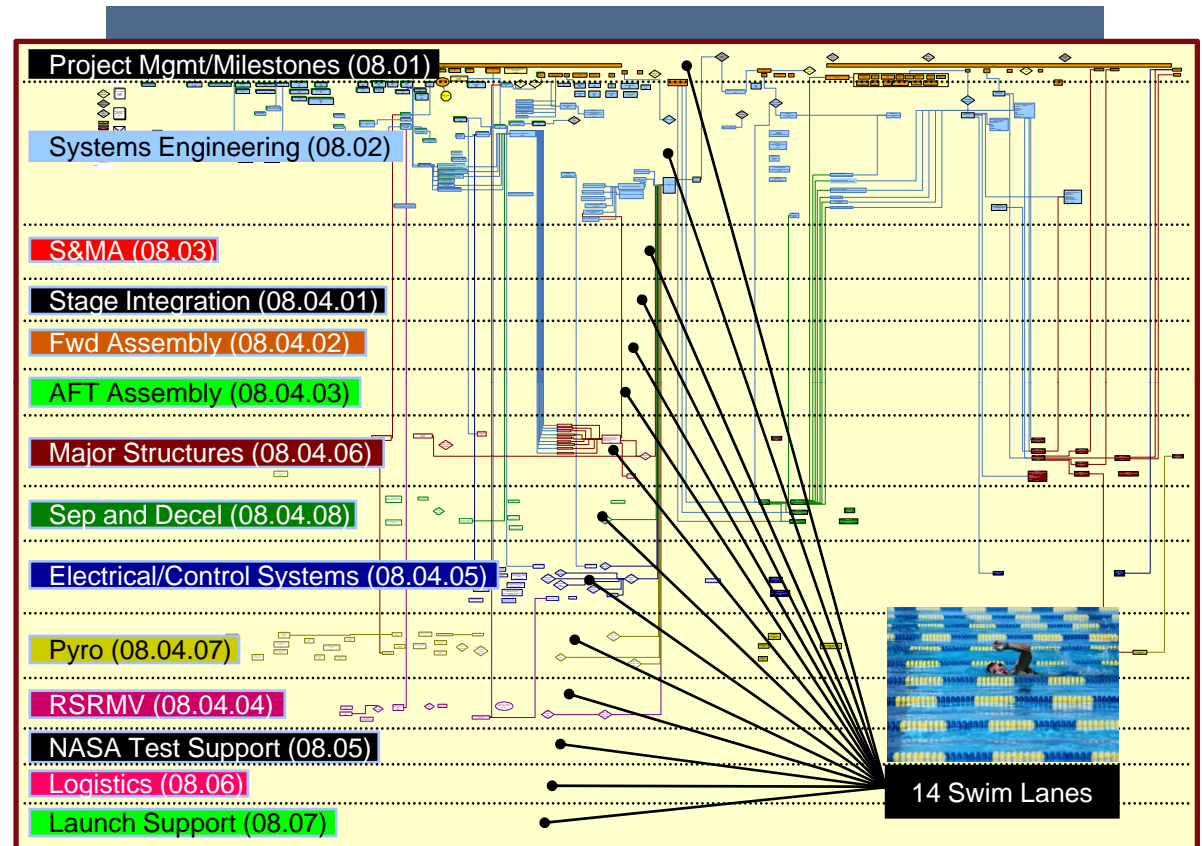

Building Block for an Integrated Master Schedule



Keys to Successful Ares I Development



Innovation ... Delivered.

- Define milestones and objectives
- Create integrated logic flow
 - Define tasks
 - Understand crosstalk
- Develop integrated master schedule
- Capture requirements early
- Agree on a verification plan
- Communicate frequently with team and customer
 - Eliminate communication barriers

