

NASA/TM-2009-215700



Design of a Mars Airplane Propulsion System for the Aerial Regional-Scale Environmental Survey (*ARES*) Mission Concept

Christopher A. Kuhl
Langley Research Center, Hampton, Virginia

March 2009

NASA STI Program . . . in Profile

Since its founding, NASA has been dedicated to the advancement of aeronautics and space science. The NASA scientific and technical information (STI) program plays a key part in helping NASA maintain this important role.

The NASA STI program operates under the auspices of the Agency Chief Information Officer. It collects, organizes, provides for archiving, and disseminates NASA's STI. The NASA STI program provides access to the NASA Aeronautics and Space Database and its public interface, the NASA Technical Report Server, thus providing one of the largest collections of aeronautical and space science STI in the world. Results are published in both non-NASA channels and by NASA in the NASA STI Report Series, which includes the following report types:

- **TECHNICAL PUBLICATION.** Reports of completed research or a major significant phase of research that present the results of NASA programs and include extensive data or theoretical analysis. Includes compilations of significant scientific and technical data and information deemed to be of continuing reference value. NASA counterpart of peer-reviewed formal professional papers, but having less stringent limitations on manuscript length and extent of graphic presentations.
- **TECHNICAL MEMORANDUM.** Scientific and technical findings that are preliminary or of specialized interest, e.g., quick release reports, working papers, and bibliographies that contain minimal annotation. Does not contain extensive analysis.
- **CONTRACTOR REPORT.** Scientific and technical findings by NASA-sponsored contractors and grantees.

- **CONFERENCE PUBLICATION.** Collected papers from scientific and technical conferences, symposia, seminars, or other meetings sponsored or co-sponsored by NASA.
- **SPECIAL PUBLICATION.** Scientific, technical, or historical information from NASA programs, projects, and missions, often concerned with subjects having substantial public interest.
- **TECHNICAL TRANSLATION.** English-language translations of foreign scientific and technical material pertinent to NASA's mission.

Specialized services also include creating custom thesauri, building customized databases, and organizing and publishing research results.

For more information about the NASA STI program, see the following:

- Access the NASA STI program home page at <http://www.sti.nasa.gov>
- E-mail your question via the Internet to help@sti.nasa.gov
- Fax your question to the NASA STI Help Desk at 443-757-5803
- Phone the NASA STI Help Desk at 443-757-5802
- Write to:
NASA STI Help Desk
NASA Center for AeroSpace Information
7115 Standard Drive
Hanover, MD 21076-1320

NASA/TM-2009-215700



Design of a Mars Airplane Propulsion System for the Aerial Regional-Scale Environmental Survey (*ARES*) Mission Concept

Christopher A. Kuhl
Langley Research Center, Hampton, Virginia

National Aeronautics and
Space Administration

Langley Research Center
Hampton, Virginia 23681-2199

March 2009

Trade names and trademarks are used in this report for identification only. Their usage does not constitute an official endorsement, either expressed or implied, by the National Aeronautics and Space Administration.

Available from:

NASA Center for AeroSpace Information
7115 Standard Drive
Hanover, MD 21076-1320
443-757-5802

TABLE OF CONTENTS

1.0	Introduction	3
2.0	Mission Description.....	3
2.1	Concept of Operations	3
2.2	Target Region.....	4
2.3	Atmospheric Flight System (Airplane)	5
3.0	Propulsion Subsystem Trade Studies	6
3.1	Propeller Development	6
3.2	Electrical Propulsion Systems.....	6
3.3	Combustion Engine Systems.....	7
3.4	Rocket Systems	7
3.5	Airplane Propulsion Subsystem Selection.....	8
4.0	Bipropellant Rocket Subsystem Design.....	9
4.1	System Schematic and Layout	9
4.2	High Pressure Helium Storage Tank.....	12
4.3	Propellant Tanks	12
4.3.1	Tank Design.....	12
4.3.2	Propellant Management Device (PMD) Design	13
4.4	Bipropellant Thrusters.....	15
4.4.1	22N Satellite Reaction Control Thruster Options.....	15
4.4.2	AMPAC-ISP 22-N Columbian Thruster	16
4.4.3	Thruster Mounting and Orientation	17
4.5	Thruster Valves	18
4.6	Propellant Isolation and Flow Control Hardware	19
4.6.1	Pyrotechnic-actuated Valves (Pyrovalves)	19
4.6.2	Line Filters.....	19
4.6.3	Check Valves	19
4.6.4	Helium Regulator.....	20
4.6.5	Flow Venturis	20
4.6.6	Service Valves	20
4.6.7	Fluid Field Joints	20
4.7	Command and Instrumentation	20
4.7.1	Temperature Sensors	21
4.7.2	Pressure Transducer.....	21
4.8	Hardware Integration	22
5.0	Master Equipment List	23
6.0	Propulsion Subsystem Performance	24
6.1	Thruster Firing – Thermal Impact.....	24
6.2	Thruster Plumes	26
6.3	Thruster Firing Logic.....	27
6.4	Airplane Flight Simulation.....	27
6.5	Airplane Flight Duration and Range.....	27
7.0	Operational Procedures	29
7.1	Propellant Loading Procedures	29
7.2	System Activation Sequence.....	29
7.3	Component Qualification Requirements.....	30
7.4	Ferric Nitrate Mitigation	31
8.0	Acknowledgements	32
9.0	Acronyms	32
10.0	References	33

TABLE OF FIGURES

Figure 1. Mission Concept Overview	3
Figure 2. Target Region.....	4
Figure 3. ARES Airplane Aero-shell Configuration	5
Figure 4. ARES Airplane Geometry.....	5
Figure 5. ARES Airplane Propulsion Subsystem Schematic	10
Figure 6. Helium Composite Over-wrapped Pressure Vessel	12
Figure 7. Propellant Tank and PMD Design	14
Figure 8. AMPAC-ISP 22N Thruster Details.....	16
Figure 9. Triple Thruster Orientation and Alignment	17
Figure 10. Triple 22N In-Line Thruster Mounting and Assembly	18
Figure 11. Pyrovalve - Conax Model 1832-205	21
Figure 12. Liquid Filter – Vacco Model F1D10558-01	21
Figure 13. Gas-Side Filter – Vacco Model F1D10286-01	21
Figure 14. Check Valves – Vacco Model V1D10856-02.....	21
Figure 15. Helium Regulator - Vacco Model 64720-1.....	21
Figure 16. Service Valves – Moog 50E740.....	21
Figure 17. Pressure Transducer – GP:50 Model 7200.....	21
Figure 18. Propulsion System / Airframe Integration	22
Figure 19. Hot Fire Test Data for AMPAC-ISP 22N Thruster ⁹	24
Figure 20. Temperature profile for lower fuselage without heat shield.	25
Figure 21. Temperature profile of lower fuselage with heat shield.....	25
Figure 23. Rear view of Airplane showing airplane in coast (above) and with thrusters firing (below)	26
Figure 22. Side view of Airplane showing airplane in coast (above) and with thrusters firing (below).	26
Figure 24. Thruster Duty Cycles for No Turbulence Conditions	28
Figure 25. Thruster Duty Cycles for Severe Turbulence Conditions	28

TABLE OF TABLES

Table 1. ARES Airplane Parameters	5
Table 2. Comparison of Propulsion System Options	6
Table 3. Rocket System Propellant Candidates.....	7
Table 4. Propulsion System Components.....	9
Table 5. Propulsion Component Functional Descriptions	11
Table 6. Fuel Extraction Concepts	13
Table 7. Mars Airplane Commercial 22N Thruster Options	15
Table 8. AMPAC-ISP 22N Thruster Characteristics.....	16
Table 9. Propulsion System - Master Equipment List.....	23
Table 10. Propulsion System Simulated Performance Summary	27
Table 11. Airplane Propellant Loading Procedure	29
Table 12. Component Qualification Requirements	30
Table 13. ARES Ferric Nitrate Mitigation Recommendations.....	31

1.0 INTRODUCTION

The Aerial Regional-Scale Environmental Survey (ARES) is a Mars exploration mission concept with the goal of taking scientific measurements of the atmosphere, surface, and subsurface of Mars by using an airplane as the payload platform. ARES team first conducted a Phase-A study for a 2007 launch opportunity, which was completed in May 2003. Following this study, significant efforts were undertaken to reduce the risk of the atmospheric flight system, under the NASA Langley Planetary Airplane Risk Reduction Project. The concept was then proposed to the Mars Scout program in 2006 for a 2011 launch opportunity. This paper summarizes the design and development of the ARES airplane propulsion subsystem beginning with the inception of the ARES project in 2002 through the submittal of the Mars Scout proposal in July 2006.

2.0 MISSION DESCRIPTION

The Aerial Regional-scale Environmental Survey (ARES) mission expands upon other Mars exploration missions, including Viking, Mars Global Surveyor (MGS), Odyssey, and the Mars Exploration Rovers (MER), to examine the structure and evolution of Mars' atmosphere, surface, and interior. The ARES atmospheric flight system will fly above the Southern Highlands to study crustal magnetism, atmospheric boundary layer composition, chemistry and dynamics, and also to explore for near-surface water.

2.1 CONCEPT OF OPERATIONS

The ARES concept has a baseline launch date from Kennedy Space Center in October, 2011 on a Delta II 2925, placing it on a 10.4 month trajectory to Mars. ARES will utilize a Type II interplanetary trajectory with a series of five planned trajectory correction maneuvers (TCMs) with a final direct entry into Mars. The entry system (aeroshell and atmospheric flight system) will separate from the carrier spacecraft before entering Mars atmosphere. The carrier spacecraft performs a divert maneuver to a Mars flyby trajectory, enabling it to relay to Earth the science and engineering data collected during the airplane flight. Mars Reconnaissance Orbiter (MRO) will serve as a redundant data return path for critical data. An overview of the mission concept is shown in Figure 1.

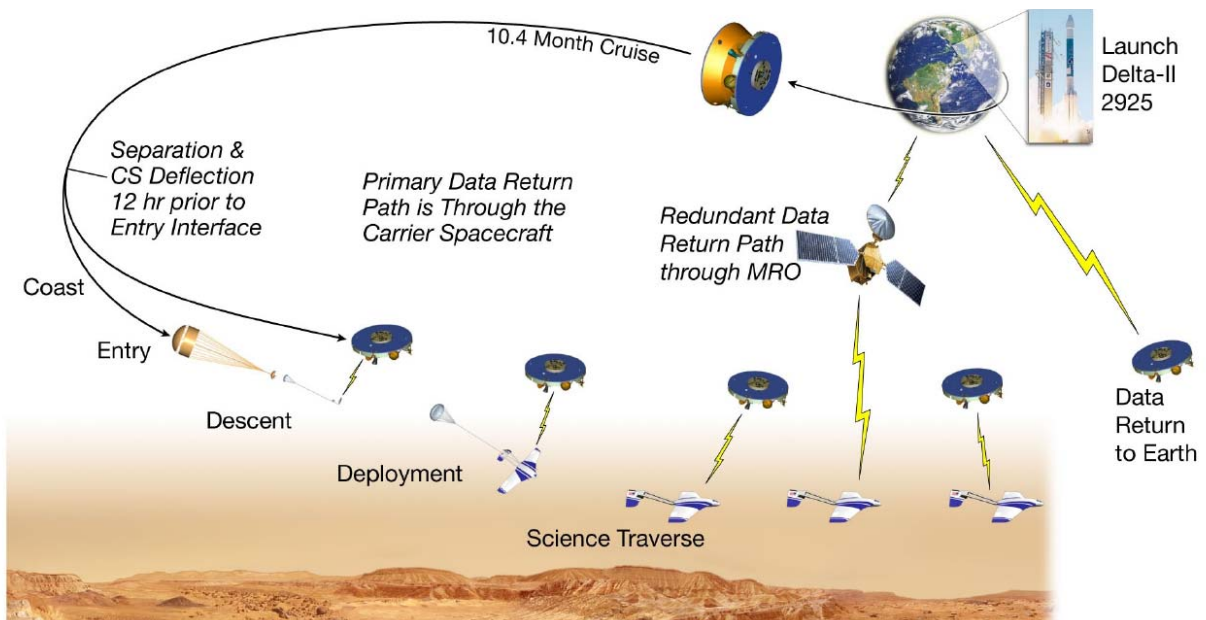

Figure 1. Mission Concept Overview

2.2 TARGET REGION

The Science Target Area (STA) is a region selected by the ARES science team that provides an optimal location for achieving the science objectives¹. The STA is defined by the intersection of two regions of interest; one region with highly variable crustal magnetism and the other region where water initiated atmospheric chemistry can be studied. The combination of these two zones yields a large STA spanning 20° to 60° S latitude and 150° to 210° E longitude (See Figure 2).

During a science flight traverse of more than 70 minutes, the ARES rocket-propelled airplane will fly over 608 km obtaining measurements of crustal magnetism and the atmosphere. The reference traverse begins at a nominal delivery location of (51.2° S, 180.0° E) and travels >1.7° south prior to performing an aeromagnetic survey defined by two additional parallel North-South tracks, each of length 100 km, shown in Figure 2. Data is relayed to the fly-by spacecraft and by a redundant path to the MRO orbiter. At the end of the traverse, the airplane impacts the surface, ending the atmospheric flight segment of the mission. No data is assumed to be transmitted from the airplane after surface impact.

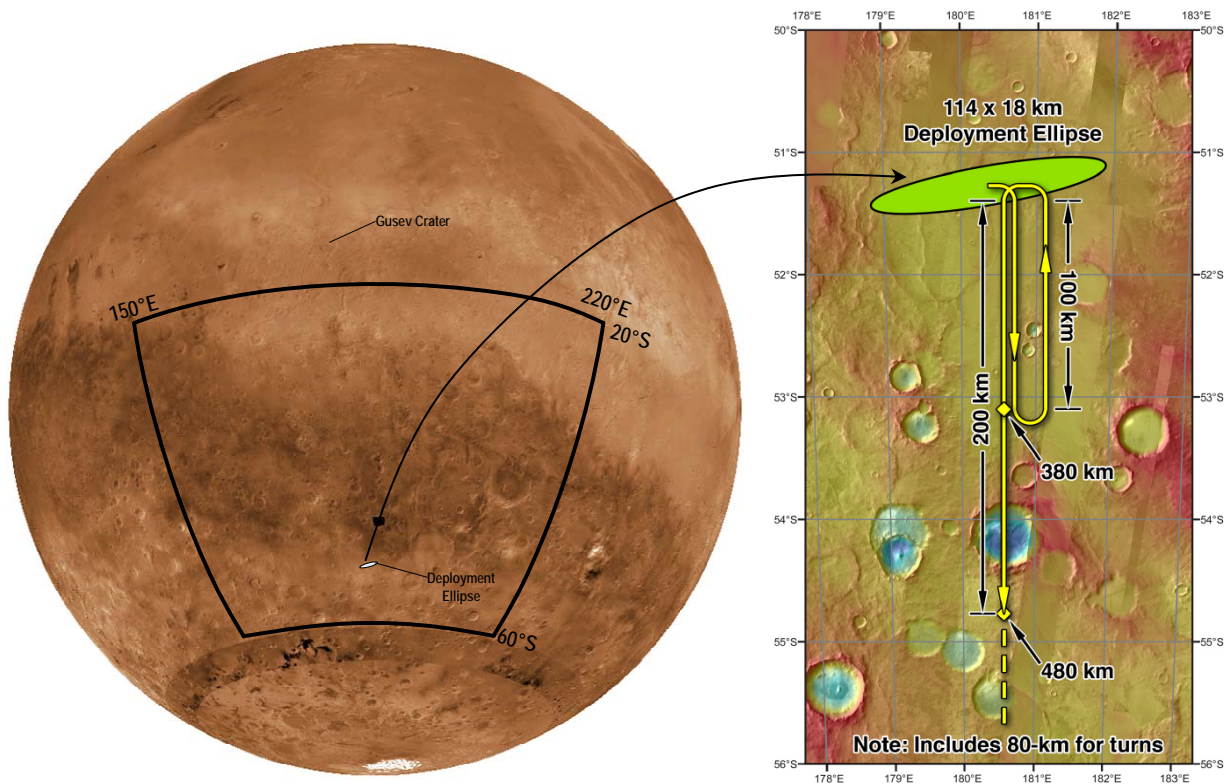

Figure 2. Target Region.
-20° to -60° Latitude, 180° Long (+/- 30°)

2.3 ATMOSPHERIC FLIGHT SYSTEM (AIRPLANE)

The ARES Atmospheric Flight System (AFS) includes the airplane, its subsystems and the science payload. Continued analyses and focused trade studies, augmented by experimental results from wind-tunnel and flight testing, have matured the airplane and subsystem designs well beyond the fundamental conceptual level. A robust airplane configuration has been achieved through several design cycles, with the airplane outer mold line frozen since 2004, resulting in significant vehicle performance and reliability improvements. The airplane geometry is depicted in Figure 4. Delivery of the ARES airplane into the atmosphere of Mars requires an entry aero-shell. The primary configuration constraint is packaging of the airplane into the entry aero-shell in a way that accommodates the environments of launch and entry (Figure 3). The airplane shape is derived from the aero-shell packaging constraints and the need for subsonic flight required by the science measurements. Table 1 provides the overall mass and geometric properties for the Atmospheric Flight System¹.

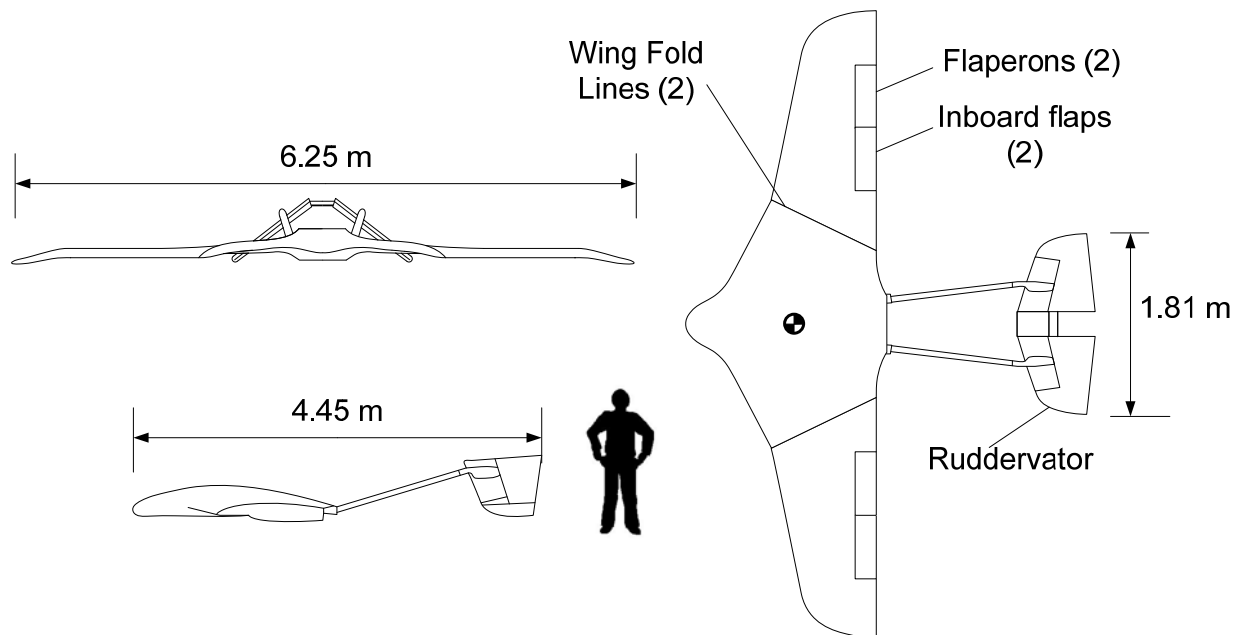

Figure 4. ARES Airplane Geometry

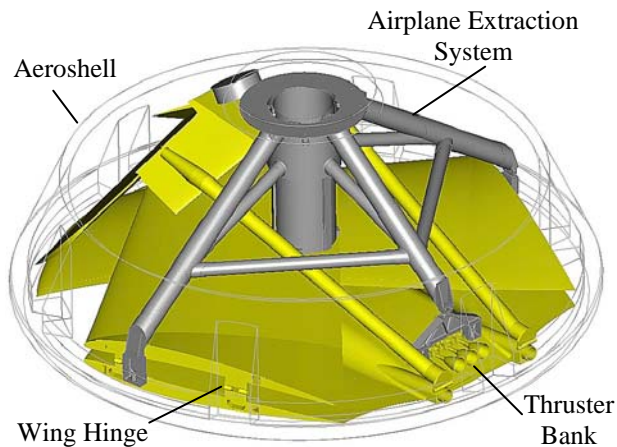

Figure 3. ARES Airplane Aero-shell Configuration

Table 1. ARES Airplane Parameters

Parameter	Value
Wing Span	6.25 m
Overall Length	4.45 m
Overall Height	0.7 m
Reference Wing Area	7.0 m ²
Mean Aerodynamic Chord	1.25 m
Dry Mass (CBE)	112 kg
Propellant Load	45 kg
Cruise Speed	145 m/s

3.0 PROPULSION SUBSYSTEM TRADE STUDIES

Propulsion subsystem capabilities are critical to establishing an airplane’s performance and flight envelope. This is especially true for an airplane that must be stowed in an aero-shell (See Figure 3), which imposes strict mass and volume limits on the airplane and subsystems. In selecting a propulsion subsystem technology for the airplane, two competing criteria were used to evaluate each system; flight range and implementation risk. The first criterion for propulsion subsystem technology selection is the ability of the airplane to achieve ascience range requirement of at least 480 km of flight. The second criterion relates to implementation risk of the propulsion system. The cost constraints and risk posture desired for Mars Scout missions require maximizing the use of existing, flight proven hardware. Extraction and deployment of the airplane from the aero-shell increases mission risk and any additional deployments necessitated by a propulsion subsystem, such as propeller blades, are heavily considered in the final propulsion subsystem selection. Various propulsion subsystem options, listed in Table 2, were examined to determine the candidate that best balanced the competing criteria of maximizing flight range and minimizing technical risk². To stay within mass constraints of the 185 kg airplane, the propulsion subsystem total mass was constrained to a maximum of 63 kg; 18 kg for hardware and about 45 kg for propellants. (*During system design iterations, the amount of fuel varies slightly depending on available mass margin on the airplane*). Results of the propulsion system analyses are listed in Table 2 and described below³.

Table 2. Comparison of Propulsion System Options

Propulsion Category	System Description	Dry Mass [kg]	Fuel Load [kg]	Flight Hours	Range [km]	TRL	Development Effort
Electrical Propulsion Systems	Fuel Cell	48	15	3.0	1512	4-5	HIGH
	Battery	63	0	0.4	202	4-6	MED
Combustion Engine Systems	Piston Expander Engine	19	44	2.0	1008	4-5	HIGH
	4 Cycle Combustion Engine	21	42	4.1	2066	4-5	HIGH
Rocket Systems	Bipropellant Rocket	15	48	1.2	605	7-9	LOW
	Monopropellant Rocket	11	52	0.9	454	7-9	LOW

3.1 PROPELLER DEVELOPMENT

Electrical and combustion engine systems require the use of a propeller for generating the needed thrust. Propeller technology for use in the Mars atmosphere is an immature technology (TRL~3). Primary limitations are the aerodynamic performance needed to generate thrust, the likely need for supersonic tips speeds, and the potential for blade erosion or performance losses. Additionally, propeller blade diameters will be significantly large relative to the airplane, resulting in challenges to packaging, unfolding, and deployment of the propellers prior to flight.

3.2 ELECTRICAL PROPULSION SYSTEMS

A simplified fuel cell system can be used to generate electrical power, which in turn can be used to power an electric motor and spin a propeller to generate thrust. This system can achieve flight of 1512 km, carrying 15 kg of fuel with a 48 kg dry mass. The relative newness of the technology (TRL~4) and lack of experience in utilizing a fuel cell as the main power system in an airplane makes it a very high risk item.

A battery propulsion system is the simplest of all systems considered and requires fewer active controls and has no mechanical components, aside from the drive train. However, batteries with high specific power have low discharge rates. This low rate forces the battery capacity higher and adds significant mass to the system. The battery systems analyzed failed to satisfy the baseline science requirement, achieving a range of only 202 km.

3.3 COMBUSTION ENGINE SYSTEMS

The concept of using a piston expander engine as a primary propeller driver dates back to the first studies of Mars aircraft design in the late 1970's. The design is based on the Mini-Sniffer, high altitude, unmanned vehicle program⁴. The piston expander engine analysis shows a capability of 1008 km of flight carrying 44 kg of hydrazine and 19 kg of propulsion hardware. Piston expander technology maintains a TRL of ~4-5 and significant development would be needed to be implemented to produce an engine that can operate within the Mars environment.

The 4-cycle internal combustion engine option for Mars flight is similar to a conventional airplane engine but would require design changes to operate within the thin atmosphere of Mars using a bi-propellant fuel and oxidizer. This option resulted in the longest flight range of 2066 km, with a dry-mass of 21 kg and a hydrazine fuel load of 42 kg. The combustion engine technology maintains a low TRL for a planetary flight application and would require a significant amount of design, testing and qualification for use in a Mars airplane.

3.4 ROCKET SYSTEMS

Rocket propulsion systems have a long heritage in space flight applications and in rocket-powered airplanes. There are a number of propellants that can power a rocket propelled airplane within the Mars environment. Several propellant combinations were considered, based on specific impulse, a stable liquid state during interplanetary cruise, and spaceflight heritage³. Potential propellant combinations were narrowed down to one monopropellant and one bi-propellant option, listed in Table 3. Hydrazine has been used in spacecraft for several decades, typically in low thrust applications like satellite station keeping. Hydrazine is decomposed through a catalytic reaction with a metal oxide. The bi-propellant combination monomethyl hydrazine (MMH) and nitrogen tetroxide (MON3) is commonly used in the satellite industry for reaction control thrusters. Both hydrazine and MON3 have freezing points above expected temperatures during interplanetary cruise, and would therefore require active thermal control. The combination of MMH and MON3 has a much higher specific impulse than hydrazine but bi-propellant systems are typically more complicated than monopropellant systems.

Table 3. Rocket System Propellant Candidates

Type	Propellant	Type	Freezing Point (°C)	Density @ 20°C (gm/cm ³)	Comb. Temp. (°C)	Isp (sec)
Mono-propellant	Hydrazine (N ₂ H ₄)	Fuel	1.5°C	1.008	633	199-230
Bi-Propellant	Monomethyl Hydrazine (MMH) (N ₂ H ₆ C)	Fuel	-52.5°C	0.874	3122	285-310
	Nitrogen Tetroxide (MON3) (97% N ₂ O ₄ , 3% NO by weight)	Oxidizer	-11.2°C	1.39		

To evaluate the rocket propulsion system options, a number of designs were considered. These ranged from passive blow-down systems to regulated systems that were controlled either by on / off pulsing or by controlling the propellant flow to the thruster. For each type of control scheme, both monopropellant and bipropellant systems were considered. The analysis of rocket systems resulted in a flight range of 605 km for the bi-propellant system and 454 km for the monopropellant system. Rocket propulsion systems, due to extensive use in military applications and the satellite industry, have a high technology readiness level between 7 and 9, which is the desirable technology maturation level for a Mars Scout mission.

Two rocket systems were viable options for a Mars airplane application, a MMH/MON3 bi-propellant system and a hydrazine mono-propellant system. Brief consideration was given to use of a MON25 oxidizer because of its lower freezing temperature, but introducing this technology with relatively low flight heritage was inconsistent with the risk posture of the Scout program. The final selection was driven by a system analysis that examined the

difference in available fuel load to support the flight range of the two systems. Since the monopropellant system is less complex, a potentially lower dry-mass would permit additional fuel load. However packaging constraints of the airplane require dual propellant tanks for the monopropellant system, resulting in essentially the same hardware configuration as the bipropellant system. Dry-mass difference between the two systems is negligible, and overall performance is based solely on the specific impulse of the propellants listed in Table 3. The monopropellant system cannot carry enough fuel to achieve the baseline science requirement of 480 km or greater flight range.

3.5 AIRPLANE PROPULSION SUBSYSTEM SELECTION

The final selection of a propulsion subsystem for the ARES airplane depended on options requiring minimal developmental effort and low technical risk while meeting science range requirements. For the electrical systems and combustion engines, a propeller is required to generate thrust, and there are significant challenges to operating a propeller in the Mars atmosphere. The propeller would need to operate near the sonic limit at its tip, which would place the blade operation in a low Reynolds number, high subsonic Mach number environment. This is outside the regime of conventional propeller design. Additionally, the size of the propeller would require it to be folded to fit within the aero-shell then deployed with the airplane during entry. Due to the aerodynamics and required deployment, the propeller would represent considerable risk for airplane operation. The technical risk caused by the need for a propeller eliminated the electrical and combustion engine systems and the monopropellant rocket was unable to meet the range requirement. Consequently, the bipropellant rocket system was selected as the only option that meets range and low technical risk requirements for the ARES mission.

4.0 BIPROPELLANT ROCKET SUBSYSTEM DESIGN

The airplane propulsion subsystem design was derived from typical bipropellant systems used on such spacecraft as the Near Earth Asteroid Rendezvous and on the Mars Observer. System design has been iterated through several trade studies and iterations to arrive at the current baseline. The propulsion subsystem is a reliable single-string architecture with redundancy existing only within the series-redundant check valves and within the thruster arrangement, where thrust margin and the ability to fly on two of three total thrusters exists.

4.1 SYSTEM SCHEMATIC AND LAYOUT

The airplane baseline propulsion subsystem is a regulated bi-propellant system with pulsed thruster control. Major components of this system consist of fuel and oxidizer tanks, a helium pressure tank, pyro valves, check valves, and thrusters. Due to cost and schedule constraints of the Scout missions, commercial hardware with significant spaceflight heritage is desirable to minimize developmental effort. ARES has meticulously researched and selected the commercially available “off-the-shelf” components and suppliers for the propulsion hardware that best meet the performance requirements and are compatible with ARES operational environment. Details of the off-the-shelf components are listed in Table 4. The schematic of this subsystem is shown in Figure 5. A description of the function of each component is provided in Table 5

Table 4. Propulsion System Components.

Component	Vendor	Heritage
Helium Pressurant Tank	Lincoln Composites 220131-1	Aircraft/missile pressure vessel
Propellant Tanks / PMDs	Lockheed Martin	Modified design of typical propellant tanks
Bipropellant Thrusters	AMPAC-ISP 5 lbf RCS	Intelsat VI >1000 flown
Thruster Valves	Moog 51-178	BSS-601, BSS-701, Star-2, Muses-C, Astro-E/F
NC Pyrotechnic Valves	Conax 1832-205	MRO, Various
Liquid Filter	Vacco F1D10558	Various spacecraft/satellites
GHe HP Filter	Vacco F1D10286	Various spacecraft/satellites
Check Valves	Vacco V1D10856-2	Developed for Mars Ascent program
Helium Regulator	Vacco 64720-1	Various Satellite programs
Flow Venturis	Flow Systems, Inc.	Various
HP Service Valves	Moog 50E740	Milstar derived
Fluid Field Joints	TBD	Various
Temperature Sensors	Analog Devices AD90	Analog Devices
Pressure Transducers	GP:50 7200	EELV, Shuttle, TRW-ABL
Thruster Valve Controller	TBD (BRE or LMA)	TBD

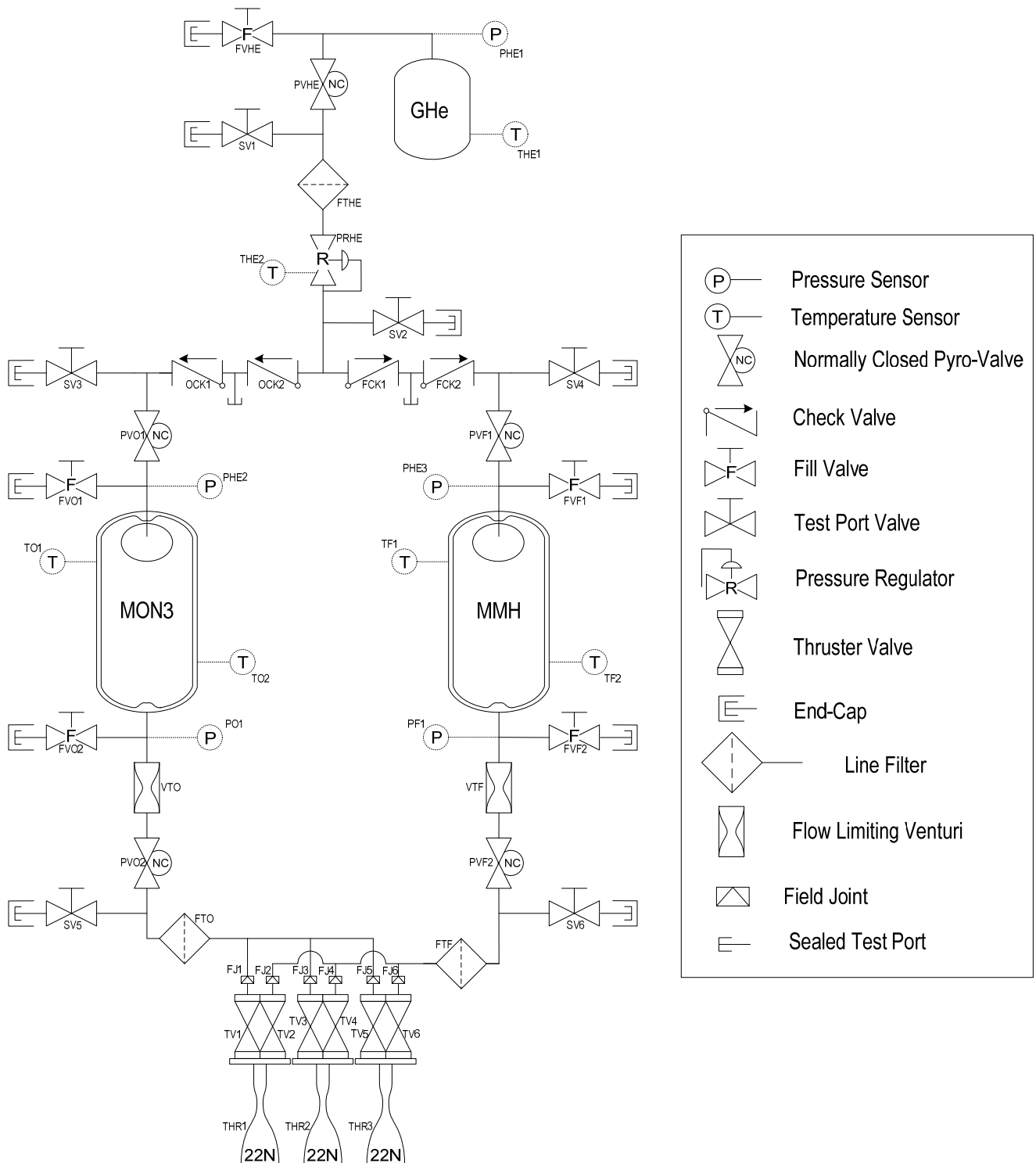

Figure 5. ARES Airplane Propulsion Subsystem Schematic

Table 5. Propulsion Component Functional Descriptions

GHe	Helium Supply	Provides high pressure helium (3000psi), used to pressurize propellant tanks to 300 psi through regulator
FVHE	Helium fill valve	Used for loading and off-loading helium. Capped before launch.
PVHE	Helium Pyrovalve	Used to isolate high pressure helium tank and protect helium pressure regulator PRHE from long term exposure to high pressure during cruise.
SV1	Service Valve #1.	Manual valve used for regulator functionality check at the system level. Capped before launch.
FTHE	Helium line filter	Located downstream of pyrovalve to filter debris from pyro activation event. Select line size finer than that of thruster valve inlets.
PRHE	Helium pressure regulator	Regulates downstream pressure to propellant tanks to nominal 300 psig. Single regulator used since dual would lead to increase propellant reserve required to cover mixture ratio uncertainty cause by possible mismatched set points.
SV2	Service Valve #2	Manual valve used for functionality and leak checking of the downstream series redundant check valves. Capped before launch.
FCK1	Fuel side check valve #1	Series redundant check valves used to alleviate large mass flow of MMH into upstream helium section.
FCK2	Fuel side check valve #2	Series redundant check valves used to alleviate large mass flow of MMH into upstream helium section. A test port is located between the two check valves to confirm functionality.
OCK1	Oxidizer side check valve #1	Series redundant check valves used to alleviate large mass flow of MON3 into upstream helium section.
OCK2	Oxidizer side check valve #2	Series redundant check valves used to alleviate large mass flow of MON3 into upstream helium section. A test port is located between the two check valves to confirm functionality.
SV3	Service Valve #3	Manual valve used for functionality and leak checking of the upstream series redundant check valves. Capped before launch.
SV4	Service Valve #4	Manual valve used for functionality and leak checking of the upstream series redundant check valves. Capped before launch.
PVO1	MON3 Upstream Pyrovalve	Used to positively isolate the upstream helium piping to avoid mixing of hypergolic fluids. MON3 vapors can migrate through the soft seals of the check valve over time.
PVF1	MMH Upstream Pyrovalve	Used to positively isolate the upstream helium piping to avoid mixing of hypergolic fluids. MMH vapors can migrate through the soft seals of the check valve over time.
FVO1	MON3 Fill/Drain Valve	Manual valve upstream of tank used for loading and offloading of MON3 into tank. Capped before launch.
FVO2	MON3 Fill/Drain Valve	Manual valve upstream of tank used for loading and offloading of MON3 into tank. Capped before launch.
FVF1	MMH Fill/Drain Valve	Manual valve downstream of tank for loading and offloading of MMH into tank. Capped before launch.
FVF2	MMH Fill/Drain Valve	Manual valve downstream of tank for loading and offloading of MMH into tank. Capped before launch.
MON3	MON3 Tank	Titanium tank with internal PMD used to store MON3 oxidizer.
MMH	MMH Tank	Titanium tank with internal PMD used to store MMH fuel.
VTO	MON3 Flow Venturi	Used to tailor downstream pressure drop to achieve proper mixture ratio at thruster injector.
VTF	MMH Flow Venturi	Used to tailor downstream pressure drop to achieve proper mixture ratio at thruster injector.
PVO1	MON3 Downstream Pyrovalve	Used to positively isolate the downstream piping to avoid mixing of hypergolic fluids.
PVF1	MMH Downstream Pyrovalve	Used to positively isolate the upstream helium piping to avoid mixing of hypergolic fluids.
SV5	Service Valve #5	Manual valve used for functionality testing of engine valves, system leak check, and to allow for positive pad pressure to be established after testing. Capped before launch.
SV6	Service Valve #6	Manual valve used for functionality testing of engine valves, system leak check, and to allow for positive pad pressure to be established after testing. Capped before launch.
FTO	MON3 Side Filter	Located downstream of pyrovalve to filter debris from pyro activation event. Select line size finer than that of thruster valve inlets
FTF	MMH Side Filter	Located downstream of pyrovalve to filter debris from pyro activation event. Select line size finer than that of thruster valve inlets
FJ1-6	Field Joints for propellant lines	Due to the OML of the airplane, thruster bank has to be installed separately from the rest of the propulsion hardware.
TV1-6	Thruster Valves	Thruster valves control the flow of MON3 and MMH into the thruster injector chamber.
THR1-3	22N Thrusters	Bank of three thruster will be independently operated based on airplane control parameters.

4.2 HIGH PRESSURE HELIUM STORAGE TANK

The helium storage tank is a conventional, composite-over wrapped pressure vessel (COPV) with a MEOP of 3000 psi and minimum burst factor of safety of 1.5. To minimize non-recurring engineering costs, the tank design is based on an existing Aircraft / Missile COPV with a maximum operating pressure of 10,000 psig and a mass of 3300 grams, manufactured by Lincoln Composites. This existing tank will be modified by shortening the barrel length from 39.4 cm to 28.1 cm and by reducing the amount of graphite over-wrap applied to the tank liner, thereby reducing the mass to approximately 1200 grams and reducing the maximum operating pressure to about 3000 psig. Further mass reduction can be achieved by modifying the inner liner thickness but would require additional developmental efforts. External dimensions of the helium tank are shown in Figure 6. The tank has an internal volume of 4100 cm³ and will hold 137 grams of helium at operating pressure.

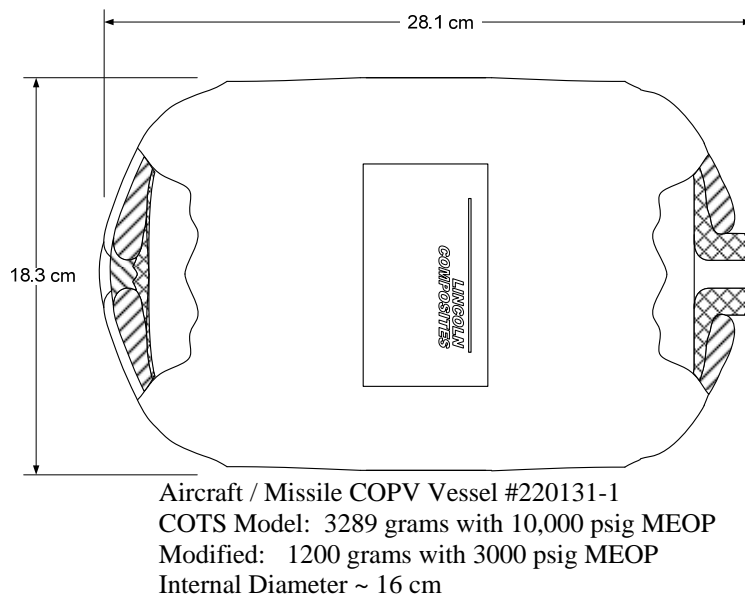

Figure 6. Helium Composite Over-wrapped Pressure Vessel

4.3 PROPELLANT TANKS

Two propellant tanks are needed to hold the fuel (MMH) and oxidizer (MON3). These tanks will be one of the few components in the propulsion system that will be specifically designed and developed for the ARES mission. Additionally, the internal propellant management devices (PMDs) will be new designs specifically tailored to the mission. The tanks shells and PMDs are not based on any existing hardware, however, the design and development are based on conventional spacecraft propulsion system hardware.

4.3.1 Tank Design

The ARES fuel and oxidizer tanks are identical, cylindrical pressure vessels made of titanium, with a minimum wall thickness of 0.076 cm (0.03"), a maximum expected operating pressure (MEOP) of 300 psig, and minimum yield and burst factors-of-safety of 1.25 and 1.4, respectively. Tanks must be designed to endure vacuum loading, thereby requiring external stiffener rings. Internal volume constraints of the atmospheric flight system provide room for a tank diameter of 23.6 cm and a cylindrical barrel length of 32 cm. Each tank shell has a mass of about 1.8 kg. While use of composite over-wrapped propellant tanks could offer mass savings, it was felt that such a development would be inconsistent with the risk posture desired for a Scout proposal. A volume of approximately 24 liters per tank would allow a propellant load of 17 kg of MMH and 28 kg of MON3 to be accommodated with approximately 10% ullage and 0.5% residual volume.

4.3.2 Propellant Management Device (PMD) Design

Due to the unpredictable gravity and acceleration environment experienced by the airplane during flight, a Propellant Management Device (PMD) must be designed into the tanks to provide a continuous flow of oxidizer and fuel from the tanks to the thruster injection chambers. Continuous flow of liquid is required to maintain the appropriate fuel/oxidizer mixture ratio in the injection chamber and to avoid pockets of helium gas in the liquid lines that could be inadvertently heated causing a burst in the system.

Several fuel extraction options were considered for the airplane, ranging from aerobatic airplane techniques to traditional spacecraft concepts⁵, as described in Table 6. A traditional spacecraft screen and channel PMD was determined to be the most promising concept for the ARES airplane.

The screen-and-channel type propellant management devices (PMDs) inside each propellant tank are used to ensure that propellant can be acquired under Mars gravity or any maneuvering or propulsive loads that may be encountered during airplane flight. A detailed design of the PMD concept resulted in a 6-channel total-communication PMD with 325x2300 stainless steel screens that will ensure gas-free propellant expulsion throughout the flight⁵. Stainless steel screens in the oxidizer tank will pose additional challenges that must be considered in the system design. Since the oxidizer (MON3) will leach iron from stainless steel leading to the formation of ferric nitrate, there is the potential for this compound to precipitate out of the oxidizer and obstruct flow passages. Titanium does not have this incompatibility with MON3, however, the bubble point for titanium screens is less than the maximum expected hydrostatic pressure which will permit gas to enter the PMD channels, which is undesirable. Therefore, stainless steel screens must be used along with a ferric nitrate mitigation strategy (See Section 7.4). Propellant tank design with internal PMD is shown in Figure 7.

Table 6. Fuel Extraction Concepts

Concept	Description	ARES Impact / Comments
Flop Tube Concept (Aerobatic Airplanes)	A weighted tube forces the free end of the tube to move with varying acceleration so the tube remains wetted.	Low expulsion efficiency and an impacting tube is undesirable.
Header Tank Concept (Aerobatic Airplanes)	Multiple tanks connected by check valves that reside above the engine and are gravity fed	Concept is weight and space prohibitive for ARES
Metallic Diaphragm	Thin metal diaphragm pressurized on one side and “rolls” open as propellant drains	Not suited for tanks with length to diameter > 2. Also not suitable for multiple loading and draining
Bellows	Provides reduction of internal volume of tank through expanding metal bellows	Concept is usually heavy and new development will be required for titanium
Elastomeric Diaphragm	Internal membrane that is pressurized on one side to provide positive expulsion	Not compatible with MON3 oxidizer.
Screen and Channel PMD	Concept has multiple enclosed flow paths that converge at tank exit. PMD relies on pressurized tank for expulsion	Best option for ARES airplane, high expulsion efficiency

A dynamic propellant slosh analyses was conducted based on the expected acceleration environment of the airplane during extraction and flight⁵. Along with the PMD channels, a center barrier acting as a baffle is included at the inside center of each tank to minimize sloshing during flight. A small screen window provides controlled movement of propellant between compartments. Residual propellant will exist in the tank when gas first enters the tank outlet. It is at this point when the propulsion system functionality is assumed to be over since gas in the liquid-side propellant lines could result in a burst in the system. The residual propellant in the tanks as well as propellant left in some of the PMD channels is estimated to be about 3-6% of the original fuel load, resulting in an expulsion efficiency ranging from 94-97%.

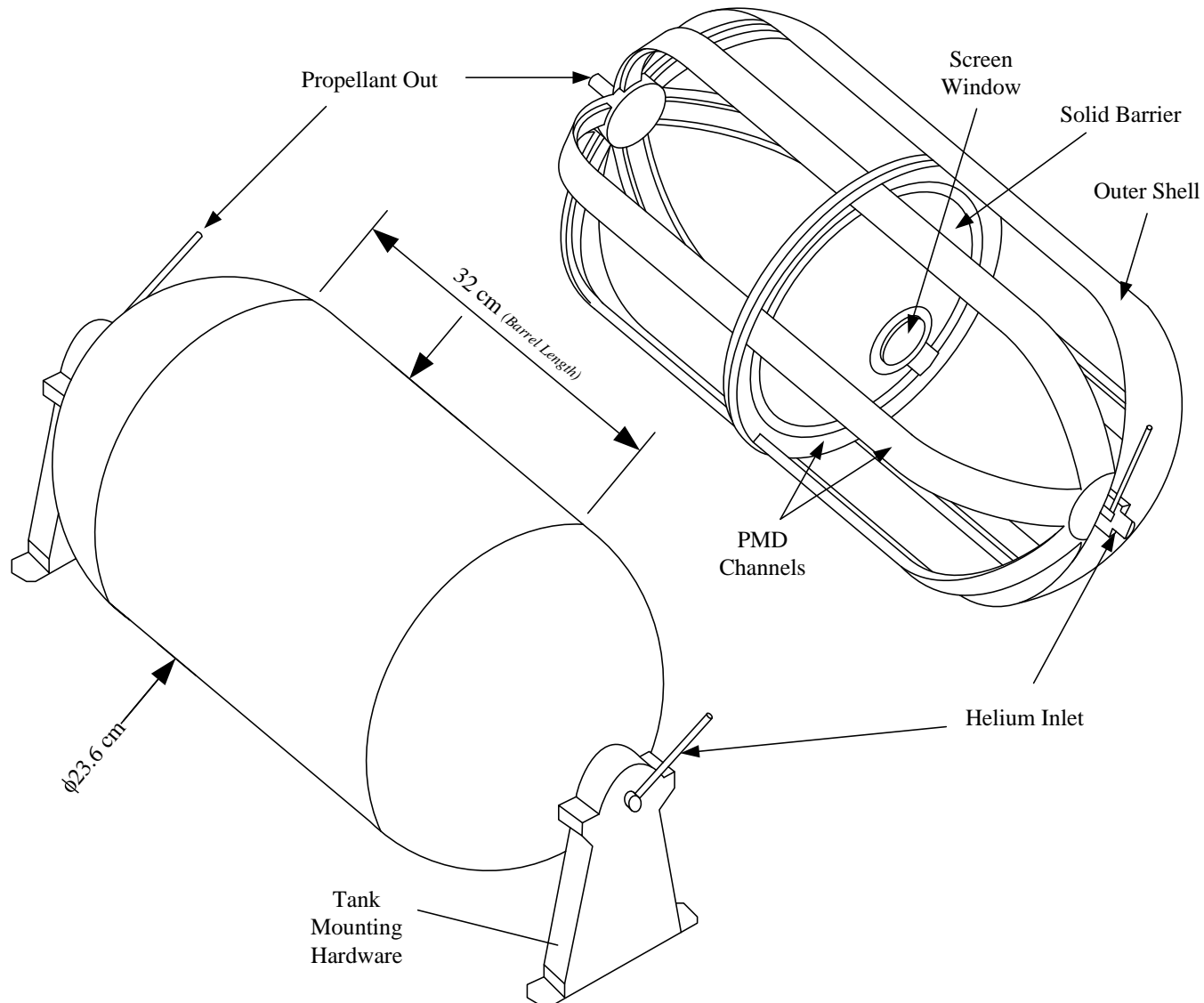

Figure 7. Propellant Tank and PMD Design

4.4 BIPROPELLANT THRUSTERS

The ARES airplane requires 40N of thrust to maintain flight with a 50% margin to accommodate climbs, accelerations, and turbulent conditions. The first baseline airplane proposed in 2003 to the Mars Scout Program⁶ utilized a single 62N thruster (AJ10-220) manufactured by Aerojet, which is the only heritage thruster available in this range of thrust. With concerns about the availability of tooling for manufacturing this thruster, as well as the non-recurring costs that would be imposed on the program (since the last thruster was manufactured over 10 years ago), other options using more readily available thrusters were considered in a detailed trade study. This trade study was performed at NASA Langley Research Center under the Planetary Airplane Risk Reduction project in 2005 to examine the option of using multiple, smaller thrusters in place of a single large thruster with the goal to reduce overall cost, schedule, and technical risk⁷. The smaller thrusters that were considered included an array of various 5-lbf (22N) common reaction control thruster used on many satellites.

4.4.1 22N Satellite Reaction Control Thruster Options

A listing of readily available “off-the-shelf” 22N thrusters is shown in Table 7⁷. Thousands of these types of thrusters have been built and flown on numerous programs, including MILSTAR and Intelsat VI. The AMPAC-In-Space Propulsion 22N Columbian thruster was chosen as the baseline thruster for the three-thruster system. This thruster was qualified under the Intelsat VI satellite program and over 1000 units have flown to date. An alternate thruster chosen was the Aerojet R-6C, which is an almost identical engine with similar production numbers and similar heritage.

Table 7. Mars Airplane Commercial 22N Thruster Options

Vendor	Aerojet	Aerojet	AMPAC-ISP (ARC)	AMPAC-ISP (ARC)	Astrium - EADS
Model	R-6C	R-6D	5 lbf	5 lbf	S22-02
Chamber Material	C103	C103	C103	Pt/Rh	Pt/Rh
Status	COTS Item	Existing Design	COTS Item	Existing Design	Existing Design
Isp [sec]	293	294	291	300	285
Area Ratio	150	150	150	150	150
Mixture Ratio (nom)	1.65	1.65	1.65	1.6	1.65
Feed Press [psia]	220	220	220	220	290
Chamber Press [psia]	116	125	125	125	125
Valve Model	Mg 51-330	Mg 51-136	Mg 51-178	Mg 51-178	Mg 51-178
Thruster Mass [kg]	0.54	0.4	0.45	0.47	0.49
Valve Mass [kg]	0.14	0.27	0.19	0.19	0.19
Total Mass [kg]	0.68	0.67	0.64	0.66	0.68
ROM Cost [M\$]	> \$100k	unkn	<\$100k	<\$200k	unkn
Qual Status	Full	In-Develop	Full	In-Qual	In-Develop
Number Flown	>600	0	>1000	0	0
Heritage	MILSTAR GOES ISRO Insat 2B	Evolve from R-6C Thruster	Telecom Intelsat VI	Evolve from C103 5lbf Thruster	Astrium 10N Thruster

4.4.2 AMPAC-ISP 22-N ColumbiuM Thruster

AMPAC-In-Space Propulsion (formerly Bell Aerospace and Atlantic Research Corporation) developed a family of 5 lbf bipropellant engines using different valve configurations ranging from dual seat solenoid valves to single seat torque motor valves. These engines have demonstrated extremely long life of 100,000 seconds of steady state firing with high specific impulse ranging from 286-295s⁸. These engines have also demonstrated wide flexibility of mission duty cycle operation by firing in any duty cycle ranging from 1-100% and accumulating over 325,000 firing pulses on multiple units with a minimum of 400,000 pulses on one unit. The engine uses a unique single element injector made of a coated columbiuM alloy orifice plate with titanium alloy feed tubes and a titanium support structure. The thrust chamber is made of columbiuM alloy and coated with R512E silicide internally and externally to protect from combustion products and to provide a surface with high emissivity for radiation cooling. The injector is electron beam welded to the thrust chamber to eliminate the potential of hot gas leakage. The valve is bolted to the injector using metal seals. The thrusters were designed, built, and qualified for the Intelsat VI series spacecraft. A diagram of the 22N baseline thruster used in this study is shown in Figure 8. Exit diameter is 5.4 cm and the total length of the thruster and attached valve, including shown inlet tubing, is approximately 27.3 cm. The valve is shown with the Moog series redundant solenoid valve model Mg 51-178. A summary of performance characteristics of the 22N thruster is shown in Table 8.

Table 8. AMPAC-ISP 22N Thruster Characteristics

Fuel / Oxidizer	MMH / MON3
Thrust	22N
Specific Impulse	293 s
Area Ratio	150:1
Inlet Pressure Range	94 – 400 psi
Feed Temperature	70°F Nominal 105°F Max SS Operation 160°F Pulsed Mode SS
Chamber Press (nom)	125 psia
Max Impulse	2,668,800 N-s
Min Impulse Bit	0.045 N-s
Nozzle Exit Diameter	5.4 cm
End to End Unit Length	27.3 cm (includes valve)
Mass	0.8 kg

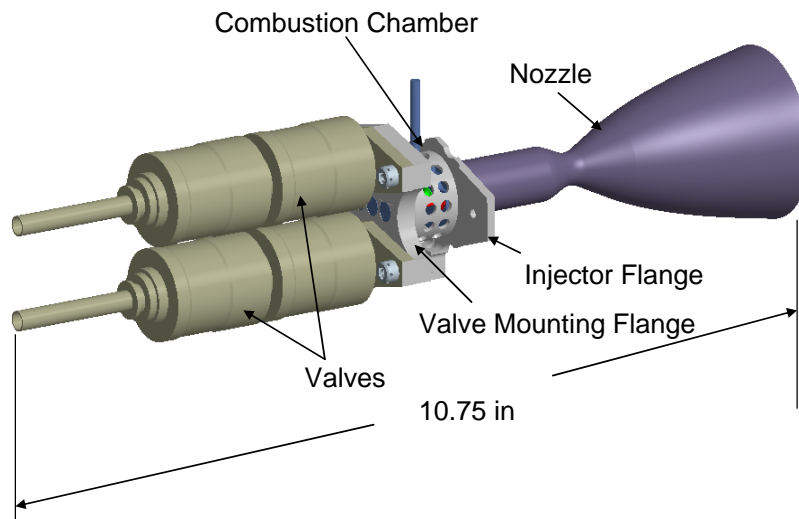

Figure 8. AMPAC-ISP 22N Thruster Details

4.4.3 Thruster Mounting and Orientation

Airplane thrusters are mounted in an in-line configuration arrangement of three 22 N thrusters. Right hand and left hand thrusters were rotated about c.g. location 4.5° to allow for adequate clearance of the valves and propellant lines. Thrusters are tilted 5.88° from the horizontal reference to direct thrust vector through the airplane c.g., shown in Figure 9.

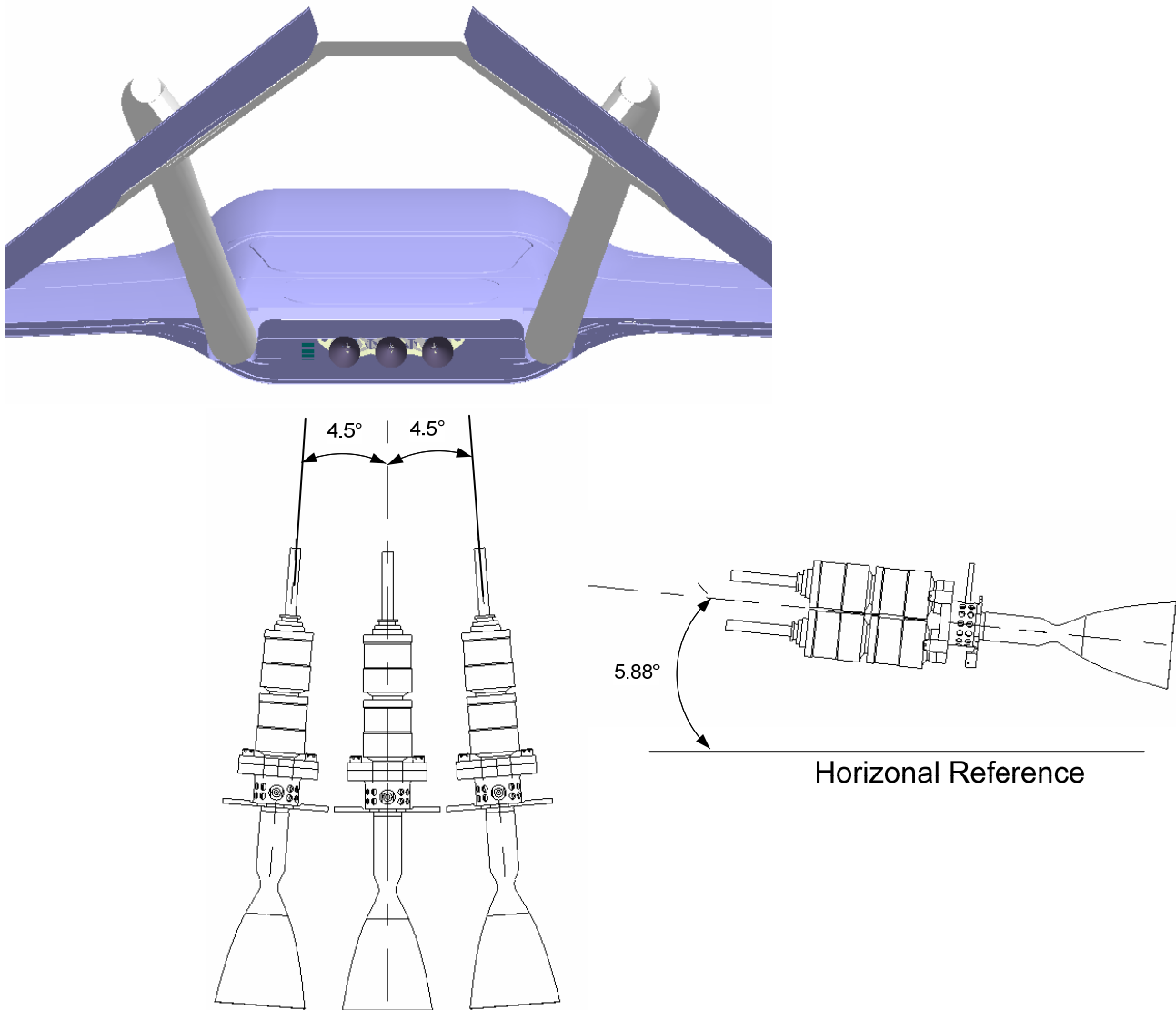

Figure 9. Triple Thruster Orientation and Alignment

The aft and forward brackets are titanium alloy and are fabricated to place thrusters in correct orientation. The aft brackets are bolted to the valve flange using existing mounting holes (see Figure 10). The thruster valve flange was chosen for bracket interface, because it only reaches a maximum temperature of 200°F at steady-state operation. The thrusters are also supported at the forward bracket and captured by titanium retaining rings. Once the retaining rings are placed into existing groove in valves, they are fastened to the forward bracket. The forward and aft brackets are bolted directly to composite airframe support structure. The design approach was to enable the ability to readily remove and reinstall the thrusters from the airframe during integration and testing.

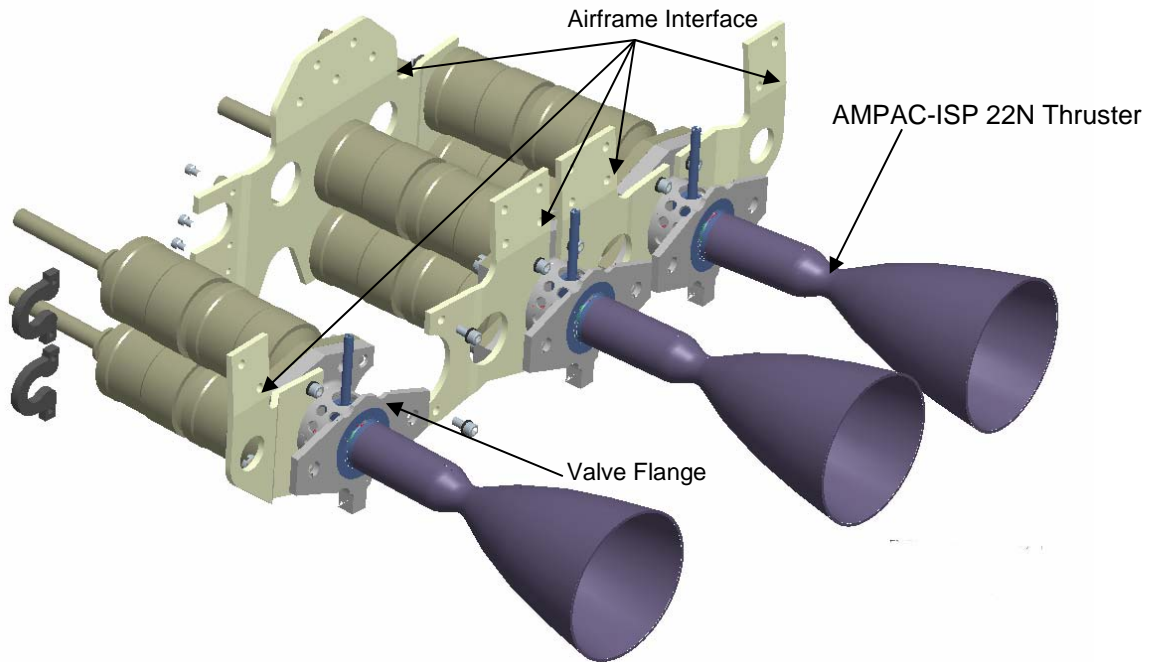

Figure 10. Triple 22N In-Line Thruster Mounting and Assembly

4.5 THRUSTER VALVES

Thruster valve chosen for the ARES airplane propulsion system is the Moog 51-178 series redundant solenoid driven valve, shown mounted to the thruster in Figure 8. Each thruster has two independent valves to control the flow of fuel and oxidizer to the combustion chamber. These valves provide on/off flow capability by energizing solenoids from voltage signals provided by the propulsion valve driver card. The valve consists of stainless steel and Teflon construction with a total mass of 0.19 kg and consumes 26 watts of power per valve when energized. The valve is normally closed with the Teflon® poppet and armature held against the valve seat by a suspension spring. When the valve coils are energized, the electromagnetic force overcomes the spring pre-load to lift the armature/poppet from the seat, providing a flow passage for the propellant. When the coil is de-energized, the spring forces the armature/poppet closed.

Since this valve is driven by electromagnetic forces, and the ARES science payload includes a magnetometry experiment, magnetic cleanliness of this valve is a key consideration. A magnetic screening of this valve model was completed at NASA GSFC in June 2006 to measure the non-operating static field and the operating dynamic field. The test demonstrated a small static field (30 nT at 1 m; 0.2 nT at 2.6 m) and a small dynamic field (60 nT at 1m; 0.4 nT at 2.6 m) per coil when actuated. With a 2.6 m distance between the magnetometers and the thruster valves, and a 20 nT static and 5 nT dynamic magnetic cleanliness requirement, reductions of the thruster valve magnetic fields are desired but not required. Since these valves have series redundant solenoids, the valve can be successfully operated by reversing the current through one of the coils, which will result in cancellation of the magnetic field strength. This was successfully demonstrated in the screening resulting in a negligible reading of the dynamic field. Operating the valve in this manner may require a partial re-qualification to determine if any adverse effects arise.

4.6 PROPELLANT ISOLATION AND FLOW CONTROL HARDWARE

Since the MMH and MON3 propellants are hypergolic, it is critical to ensure their isolation to avoid inadvertent ignition in any part of the feed system. Normally-closed, pyrotechnically-actuated valves (“pyro valves”) (PVF1 and PVO1 in Figure 5) are used to isolate the high pressure helium supply from both propellant tanks and to prevent propellant vapor migration prior to system operation. Redundant series check valves are used to ensure that there is no vapor or liquid transfer and mixing of the hypergolic propellants during the operation of the system. The possibility exists, during the long periods of inactivity, for fuel or oxidizer to seep through the check valves and condense in upstream sections of the feed system. To minimize trapping any condensed propellant in dead-end upstream sections, the series-redundant check valves for the fuel and oxidizer are located upstream of the pyro valves, which provide the long duration isolation function. Downstream of the propellant tanks, normally closed pyro valves PVF2 and PVO2 are also used to provide a redundant seal against external leakage of the propellant through the single-seat thruster valves. In addition to increasing reliability, such redundant seals are required for safety during ground handling. All manual service valves also incorporate redundant seals.

4.6.1 Pyrotechnic-actuated Valves (Pyrovalves)

ARES uses normally-closed pyrotechnic valves to positively isolate portions of the propulsion subsystem to avoid mixing of the hypergolic propellants in areas other than the combustion chamber. A total of four Conax Model 1832-205 dual initiator pyrovalves (Figure 11) and one Conax Model 1832-192 high pressure, single initiator pyrovalve provide the propellant isolation function. The valves are constructed of stainless steel with a 500 psig and 9400 psig operating pressure respectively, and a 0.02 second response time once initiated. When a current is received by the firing circuit, the initiator ignites a charge within the valve body which forces a ram downward removing a metal closure and opening the flow path. For redundancy, the pyrovalve consists of two initiators which will be fired sequentially to assure proper functioning of the valve.

The propellant tanks are isolated by two gas-side pyrovalves located just upstream (PVO1 and PVF1 from), and two liquid-side pyrovalves located directly downstream (PVO2 and PVF2). An additional high pressure pyrovalve (PVHE) is used to isolate the high pressure helium tank and to protect the helium pressure regulator (PRHE) from long term exposure to high pressure during the long cruise segment to Mars.

4.6.2 Line Filters

Small particulates in the flow stream can block narrow passages in areas such as the thruster injector chambers. Debris resulting from the firing of pyrovalves are a major source of such particulates, so line filters are placed just downstream the liquid side pyrovalves (PVO2, PVF2). ARES uses the Vacco 3/8” Low Pressure Filter Assembly F1D10558-01, which is a titanium etched disc, 25 micron filter with a 400 psig operating pressure and a mass of 0.08 kg (Figure 12). Similarly, the helium regulator is susceptible to small particles blocking the passage ways, so a high-pressure gas filter is placed downstream of the helium-tank pyrovalve (PVHE) to filter debris after pyrovalve activation. The high pressure filter is Vacco Model F1D10286-01, which is also an etched disc filter but has an operating pressure rating of 4200 psig (Figure 13).

4.6.3 Check Valves

Check valves are used in the gas-side of the propulsion system to alleviate large mass flow of MMH or MON3 into the helium section, once the pyrovalves have been activated. Since the propellant is hypergolic, any mixing of the fuel and oxidizer in the gas-side would result in combustion and most likely a pressure spike large enough to burst the tubing. Series redundant check valves were selected over parallel redundant or “quad” valves due to the single string fault policy of the airplane systems. The check valves in the propulsion system are Vacco 3/8” low pressure check valve Model V1D10856-02 (Figure 14), which is a titanium welded unit used on the Mars Ascent program. The valve has a mass of only 20 grams and an operating pressure of 550 psi.

4.6.4 Helium Regulator

A regulator is used to reduce the pressure from 3000 psi at the helium tank to the propellant tank operating pressure of approximately 300 psi. Several options exist for a flight qualified helium regulator from both space applications and defense programs such as the THAAD⁵. ARES has baselined the Vacco Model 64720-1 single stage regulator (Figure 15). Over 400 of these regulators have been flown in satellite applications over the past 18 years. The regulator has an inlet pressure range from 400 to 4200 psig and an outlet pressure range from 224 to 4200 psig. The unit has a mass of 844 grams and can handle helium flow up to 8.5 scfm of GHe.

4.6.5 Flow Venturis

Flow venturis are used on the liquid side of both the MON3 and MMH system to limit the propellant flow and tailor the feed system pressure drop to achieve the proper mixture ratio of fuel and oxidizer in the engine combustion chamber. Venturis are custom built depending on the final propellant line pressure drop characteristics. Flow Systems Inc. will provide the venturis to the ARES project.

4.6.6 Service Valves

The ARES propulsion system has a total of 11 services valves. One service valve (FVHE) is located on the helium tank and used for helium pressurizing. Four valves are used for propellant tank filling and venting, one on the gas side of each tank (PVO1 and PVF1) and one on the liquid side of each tank (PVO2 and FVF2). Two additional service valves located downstream of the liquid-side pyrovalves provide the ability to vent the volume between the pyrovalves and the thruster valves. Additional service valves are used for functionality checks of the helium regulator and check valves. Check valves are independently verified using both a service valve and a sealed test port. The high-pressure service valves are manufactured by Moog, part number 50E740 with flight heritage based on the Milstar program. These valves are manually actuated, titanium construction with a proof pressure of 3265 psig and a mass of 0.15 kg each (Figure 16).

4.6.7 Fluid Field Joints

It is desirable to have an all-welded propulsion system since field joints have a history of being unreliable, causing extra testing and care to prevent leakage or damage. The propulsion system is installed into the airplane through the upper hatch located on the fuselage. However, the three thrusters have to protrude from the bottom outer-mold-line of the airplane, making it impossible to have a completely welded system. Consequently, six field joints connecting the three thruster/valve assemblies to the propellant tubing are required so the thrusters can be mounted from underneath the airplane.

4.7 COMMAND AND INSTRUMENTATION

Propulsion system instrumentation consists of pressure and temperature sensors on the helium tank and on both the gas and liquid sides of the propellant tanks. Analog signals from the pressure and temperature sensors are fed into the State of Health Monitoring & Attitude Control (SMACI) module which is part of the ARES airplane command and data handling subsystem. A subset of these signals are split and routed externally through the aeroshell and into the spacecraft C&DH computer for state of health monitoring of the propulsion system during the cruise stage of the mission.

Commanding of propulsion system occurs during the initial pressurization of the propellant tanks and during thruster firing. During initial activation, commands originating from the airplane computer power switching boards act to arm and then fire the five pyrovalves in various locations on the propulsion system using 28VDC discrete signals. Commanding of the thruster valves is accomplished by a 28VDC circuit controlled by the valve driver card. When the valve receives the 28VDC, the solenoids open a flow passage for the propellants. The valve driver card communicates with the flight computer via RS-422 interface. Each thruster has independent fuel and oxidizer control valves, so with the triple thruster system, there are 6 channels required to operate the thrusters. Further development is required for a new or modified valve-driver card designed specifically for compatibility with the ARES architecture.

4.7.1 Temperature Sensors

The temperature sensors used to monitor various locations on the propulsion system are solid state sensors powered by 28VDC and provides an output linear to temperature of $1\mu\text{A}/\text{K}$. Temperature measurement range is from -55 to 150°C with a repeatability of $\pm 0.1^\circ\text{C}$ and a long-term drift of $\pm 0.1^\circ\text{C}/\text{month}$. The baseline component identified for the ARES mission is the AD590 Solid State Temperature Sensor manufactured by Analog Devices.

4.7.2 Pressure Transducer

Pressures in the helium and propellants tanks are monitored by the flight qualified GP:50 Pressure transducer Model 7200 (Figure 17). This device has significant flight heritage including Lockheed Martin Evolved Expendable Launch Vehicle (EELV) and Space Shuttle Upgrades. The transducer receives 28VDC excitation and provides an analog output signal to the SMACI board. Each pressure transducer has a mass of 142 grams.



Figure 11. Pyrovalve - Conax Model 1832-205



Figure 12. Liquid Filter – Vacco Model F1D10558-01



Figure 13. Gas-Side Filter – Vacco Model F1D10286-01



Figure 14. Check Valves – Vacco Model VID10856-02



Figure 15. Helium Regulator - Vacco Model 64720-1



Figure 16. Service Valves – Moog 50E740



Figure 17. Pressure Transducer – GP:50 Model 7200

4.8 HARDWARE INTEGRATION

Propulsion hardware must be packaged inside the limited volume of the airplane fuselage, along with all other hardware such as science instrumentation, avionics, communication components, power modules and support structure. Fuel and oxidizer tanks are each supported by two brackets with two mounting interfaces for each bracket that attach directly to the airplane structure. The helium tank is attached directly to the airframe through similar brackets. Propellant isolation and flow control hardware will be mounted to two separate honeycomb plates; the Propellant Isolation Assembly (PIA) Plate will consist of fuel and oxidizer pyrovalves, fill valves and service valves, and the Pressurant Control Assembly (PCA) Plate will consist of the helium tank pyrovalve, helium pressure transducer, check valves, and service valves. PIA and PCA plates will be mounted to the airframe structure using Torlon® thermal standoffs. Propellant and helium lines are supported by tube support assemblies which are bonded directly to the PIA and PCA plates and to the airframe structure. The propulsion hardware integrated within the airframe structure is shown in Figure 18.

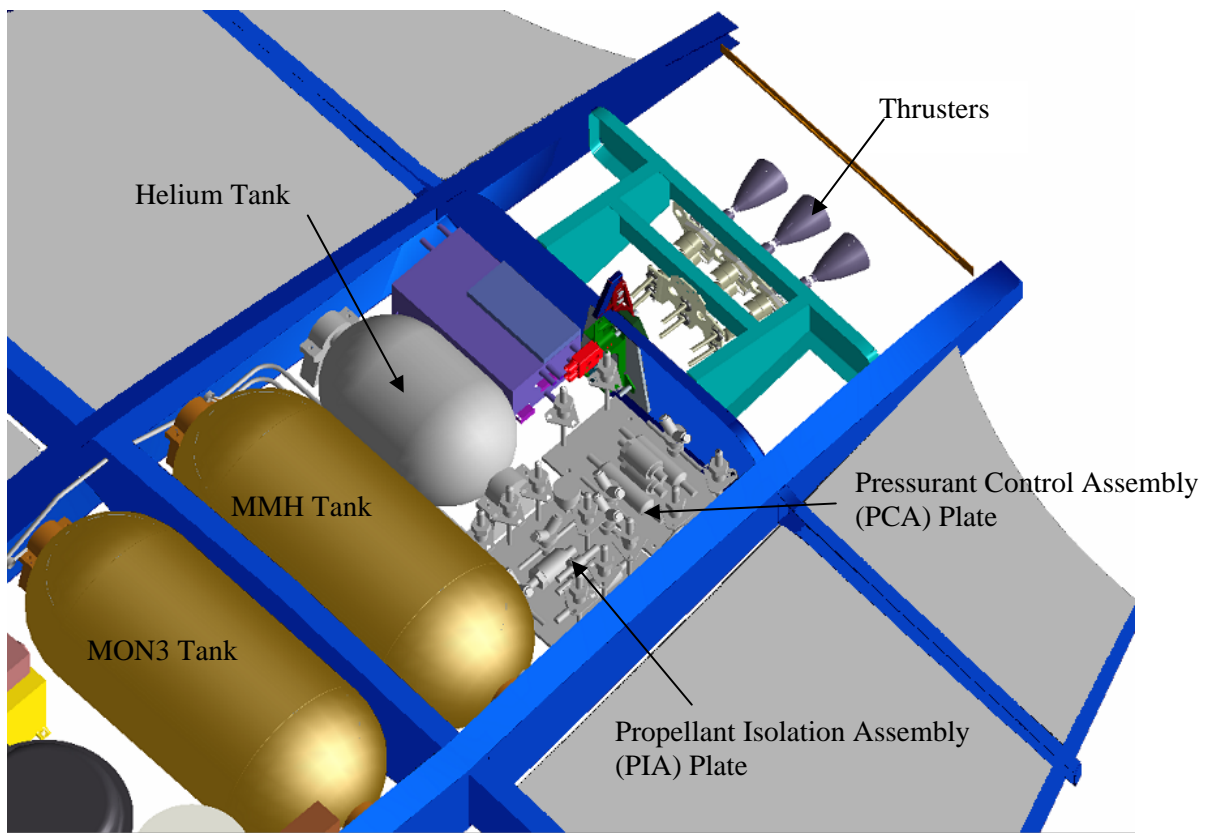

Figure 18. Propulsion System / Airframe Integration

5.0 MASTER EQUIPMENT LIST

The master equipment list of all propulsion system components, number of flight units, mass and power, is shown in Table 9. The propellant tanks (with PMDs) are the most massive components at 5275 grams total, making up about 1/3 of the total dry-mass of the system. The thruster valves use 26 watts each for a total of 156 watts of power required. Thruster valve power will not be continuous but rather cycled on and off when necessary to maintain flight. Additionally, not all thrusters will be firing simultaneously (see Section 6.4). Total CBE dry mass of the propulsion system is 16.1 kg with a peak power requirement of 167 watts.

Table 9. Propulsion System - Master Equipment List

Component	# Flight Units	Mass [grams]	Power [W]
Bipropellant Thrusters	3	1260	-
Thruster Valves	6	1140	156.0
Propellant Tank Shell & Stiffeners	2	3228	-
Propellant Management Device (PMD)	2	2046	-
Helium Pressurant Tank	1	1200	-
Check Valves	4	80	-
Helium Regulator	1	550	-
Liquid Filter (MMH & MON3)	2	360	-
HP Service Valves	11	1650	-
GHe HP Filter	1	114	-
NC Pyro. Valves	5	1020	5.0
High Pressure Transducer	1	142	0.6
Low Pressure Transducer	4	568	2.4
Flow Venturis	2	80	-
Propellant Isolation Assembly (PIA) Plate	1	100	-
Pressurant Control Assembly (PCA) Plate	1	100	-
Thruster Valve Controller	1	400	3.0
Thruster Valve Controller Chassis	1	500	-
Lines, Tubing, Fittings	1	739	-
Tank Support Brackets	1	400	-
Residual Propellant & Ullage	1	434	-
Residual Helium Gas	1	21	-
TOTALS	53	16132	167

6.0 PROPULSION SUBSYSTEM PERFORMANCE

ARES has analyzed the performance of the propulsion subsystem through flight simulations and by characterizing its impact on other subsystems and airplane structures. The thermal environment created by the firing of the thrusters was examined as well as the potential impact of plumes on airplane structures and control surfaces.

6.1 THRUSTER FIRING – THERMAL IMPACT

During operation, the thrusters reach temperatures significantly greater than the expected -60°C Mars ambient temperature. For continuous firing at room temperature, the combustion chambers of the thrusters reach approximately 1050°C in 45 seconds (Figure 19)⁹. This creates a significant temperature difference between the thrusters and outer fuselage, which will cause a large radiative heat transfer between the two components. The airplane fuselage is a composite structure consisting of an aluminum honeycomb core surrounded by face sheets of carbon fabric. Adhesive holding the carbon face sheets to the aluminum honeycomb will begin to break down at approximately 250°C . The valve flange, where the thruster bank will be mounted to the airframe, maintains a temperature near 100°C during steady state firing. During flight, two thrusters will be continuously firing. These two thrusters will reach an equilibrium temperature profile similar to the one provided by the test firing, however it will be slightly cooler due to the much lower ambient temperature on Mars and forced convection from the thrusters to the atmosphere. The third thruster will be turned on and off as needed during flight.

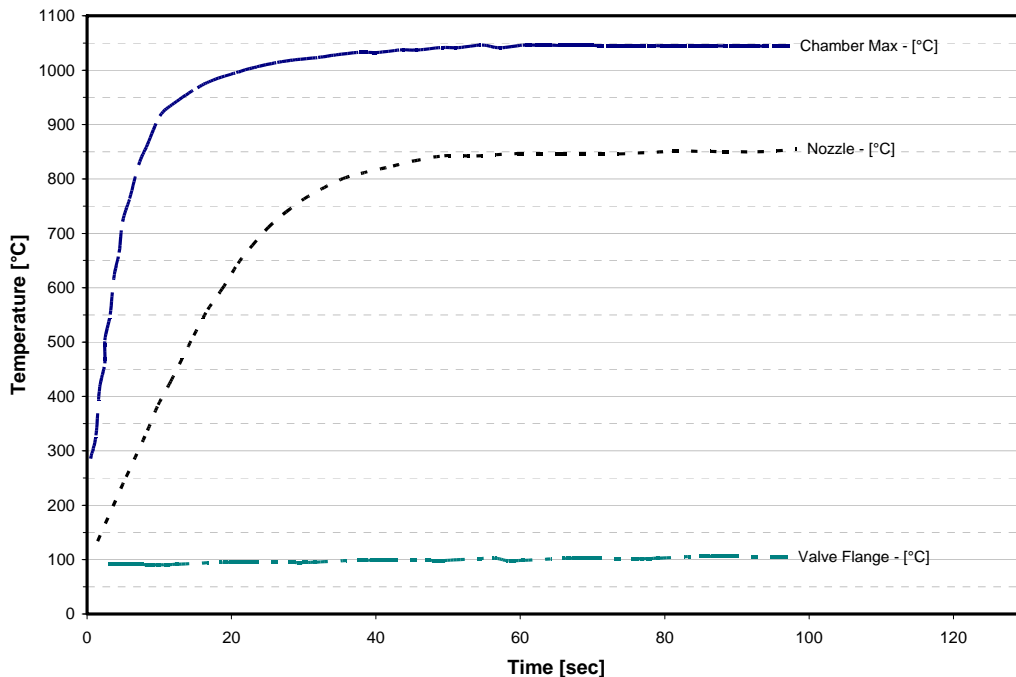

Figure 19. Hot Fire Test Data for AMPAC-ISP 22N Thruster⁹.

Based on previous thermal analyses of the three thruster system, which included heat transfer from both the thruster nozzles and the plumes, the thruster support structure will experience a maximum temperature of 139°C ⁷. However, an analysis of the lower fuselage without a heat shield (Figure 20) shows temperatures reaching 284°C , which exceeds the critical temperature (125°C) of the face sheet to honeycomb film adhesive. Consequently, a thin polished aluminum heat shield will be required to reflect the heat away, which will result in significantly lower fuselage temperatures, shown in (Figure 21). Plume temperature for analyses purposes was assumed to be 700°C . Depending on the actual plume temperature, two different heat shields can be used. A large heat shield will be required for high plume temperatures, however for lower plume temperatures, a combination of a smaller

heat shield with low emissivity paint will keep the fuselage temperatures closer to the ambient temperature. Further analyses and testing are required to obtain accurate plume temperature profiles for the expected airplane operating conditions.

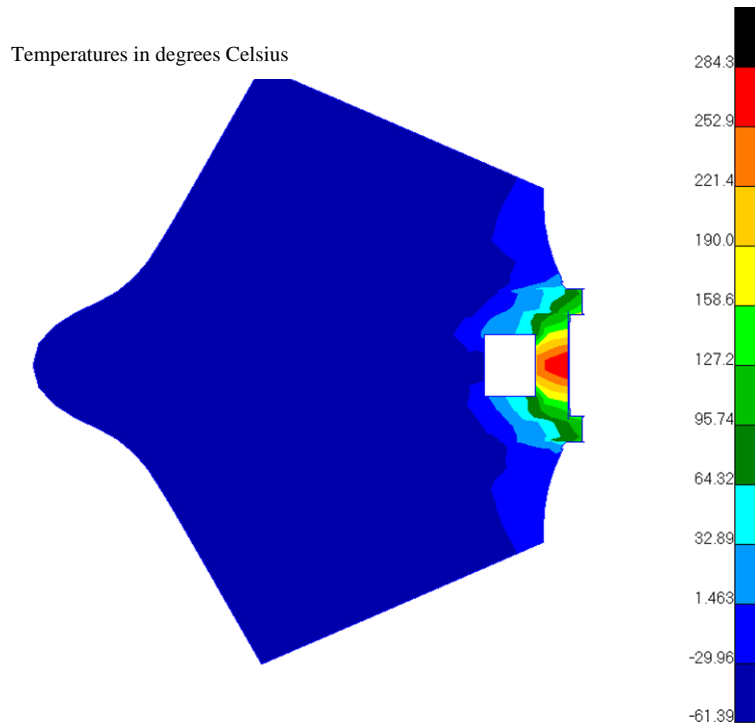

Figure 20. Temperature profile for lower fuselage without heat shield.
(Max Temperature = 284°C).

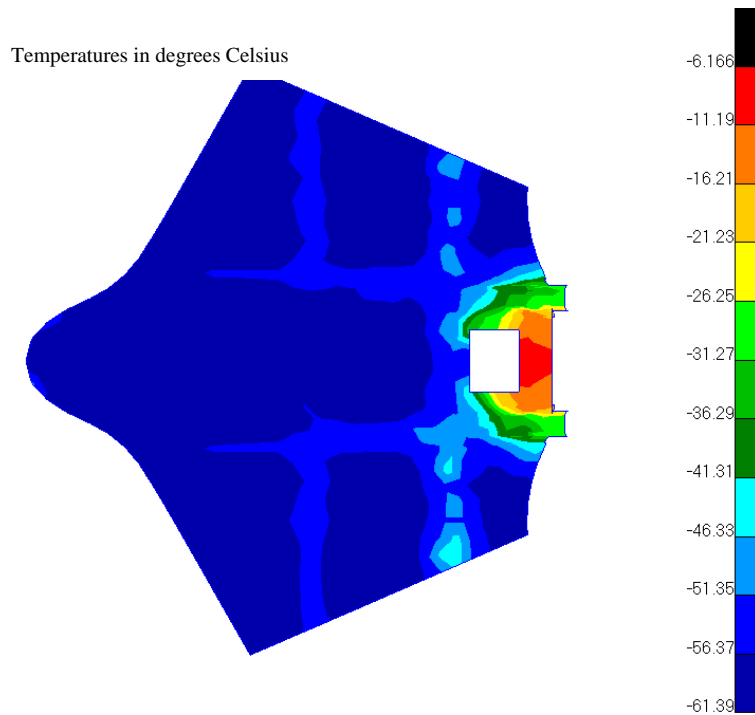

Figure 21. Temperature profile of lower fuselage with heat shield.
(Max T = -6.17°C).

6.2 THRUSTER PLUMES

Computational fluid dynamics simulations were used to evaluate possible plume interactions and aeropropulsive behavior of the airplane in the Mars atmosphere during coast and during thruster firing. The simulation modeled the 3D thruster system in a representative free-stream environment (using PAB3d and 6-DOF LaSRS). Figure 23 shows a slice through the centerline plane of spanwise symmetry, with the center thruster plume visible in the lower picture. Here, the plume is seen to slowly bend from its initial 5.88° incidence to align with the freestream flow. Figure 22 shows a slice through the CFD simulation from the rear of the airplane. The individual thruster plumes (shown in the lower picture) are well isolated and maintain angular separation, with no major interactions apparent. Sufficient clearance exists between the tail and plumes to avoid any adverse affects of flight controls or performance.

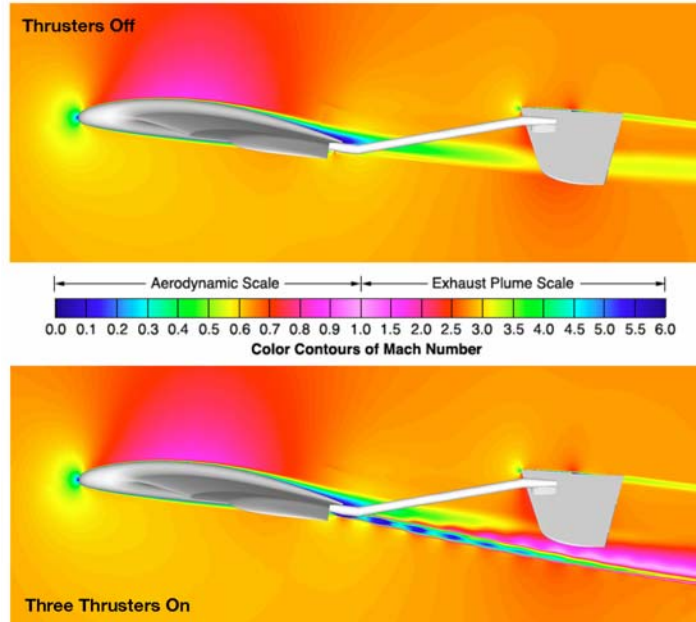

Figure 23. Side view of Airplane showing airplane in coast (above) and with thrusters firing (below).

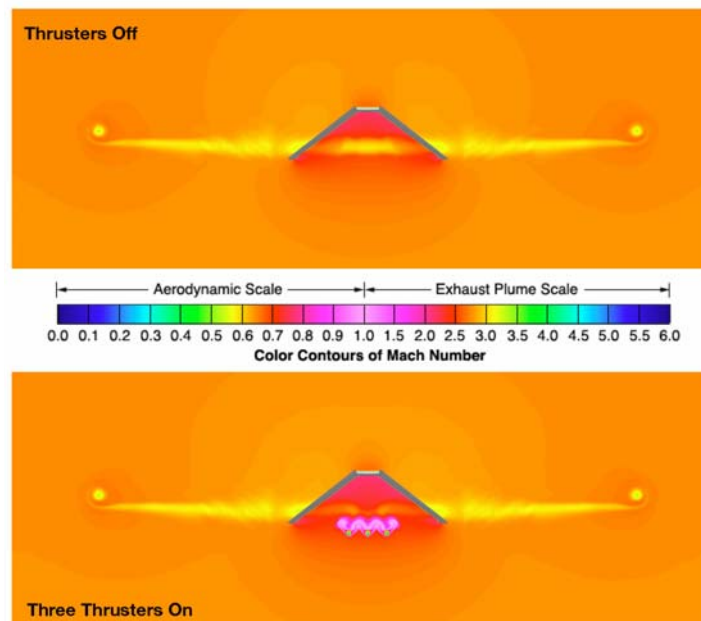

Figure 22. Rear view of Airplane showing airplane in coast (above) and with thrusters firing (below)

6.3 THRUSTER FIRING LOGIC

To control the thrust modulation in a pressure-blowdown propulsion system, on/off duty cycle adjustments are continuously generated by the control system. The thruster control law uses two key elements; a thrust period and a duty cycle. The two elements define how long the thruster is off and on (period * duty cycle). Once a thrust period has ended, the duty cycle is modified to reflect the error between the commanded Mach number and the average Mach number for that period. The firing logic for the thrusters is divided into two separate duty cycles. The primary duty cycle governs the firing of two thrusters simultaneously to provide the needed thrust to overcome drag while flying under normal conditions. The secondary duty cycle governs the firing of the third thruster and is invoked during instances where airplane acceleration or climbing is needed or under turbulent conditions when more than 44N of nominal thrust is required to maintain flight.

6.4 AIRPLANE FLIGHT SIMULATION

The flight simulation of the Mars airplane was evaluated using a 6 degree-of-freedom model from the Langley Standard Real-Time Simulation application framework¹⁰. Control logic was incorporated to hold the airplane's speed while flying a specific mission profile. Two atmospheric conditions were simulated to bound the upper and lower expected atmospheric conditions; one with no turbulence, and the other with severe atmospheric turbulence. Thruster duty cycle for the conditions of no turbulence is shown in Figure 24. The primary duty cycle is shown on the top chart and the secondary on the bottom. For conditions of no turbulence, the primary duty cycle stays predominantly around 70%, varying between 60% and 85% for the majority of flight. The secondary duty cycle shows that the third thruster is only slightly used during the initial stages of flight, when the airplane is the heaviest, and stays off during the entire remainder of flight. During severe turbulence, the data in Figure 25 shows that the two primary thrusters are fully firing at 100% duty cycle for a significant portion of the flight, and that the third thruster, or secondary duty cycle, is sparsely invoked throughout the flight and remains off for most of the flight.

6.5 AIRPLANE FLIGHT DURATION AND RANGE

The results of the simulation show that the airplane flying in no-turbulence conditions will achieve a range of about 543 km and duration of 68 minutes on a propellant load 40 kg. In severe turbulence conditions for the same fuel load, the flight range is reduced to about 536 km and the duration reduced to 66 minutes (Table 10). This averages to roughly 13.5 km/kg of propellant for the complete flight mission. With fuel consumption of 13.5 km/kg, the baseline mission using 45 kg of propellant will achieve a range of ~608 km and a duration of about 70 minutes.

Table 10. Propulsion System Simulated Performance Summary

Parameter	Value
Total AFS Mass	145 kg
Propulsion Mass	18.06 – 18.12 kg
Propellant Load	40 kg
Fuel	15 kg - MMH
Oxidizer	25 kg - MON3
Thrust	Three - 22 N
Isp	~291 s
<i>No Turbulence</i>	
Flight Duration	67.63 min
Range	543 km
Avg Fuel Usage	13.6 km/kg
<i>Severe Turbulence</i>	
Flight Duration	66.22 min
Range	536 km
Avg Fuel Usage	13.4 km/kg

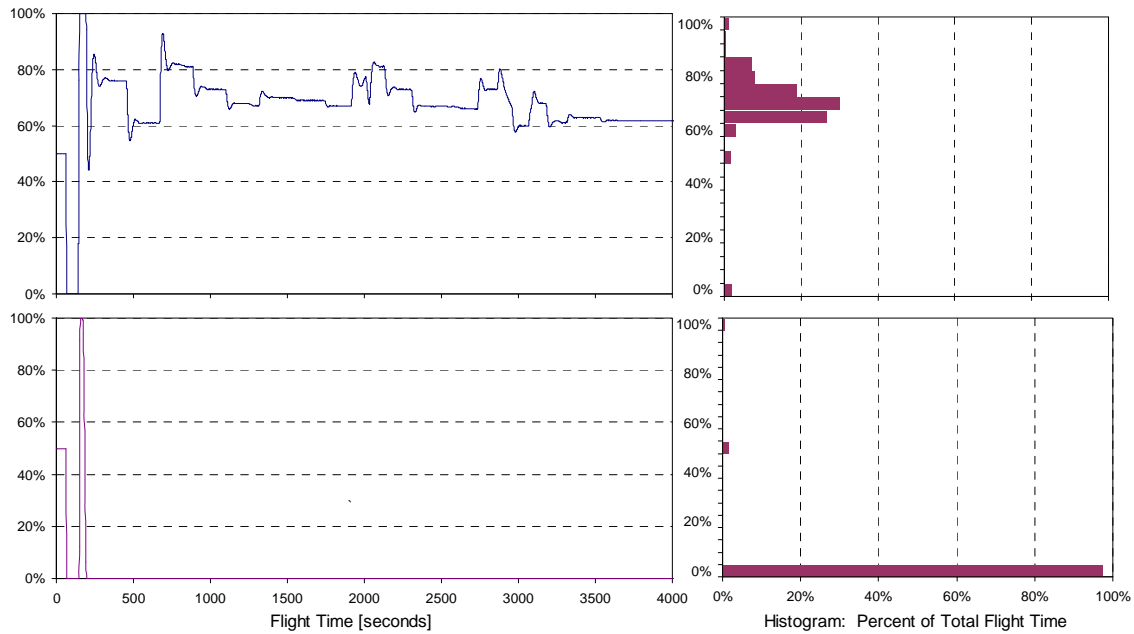

Figure 24. Thruster Duty Cycles for No Turbulence Conditions

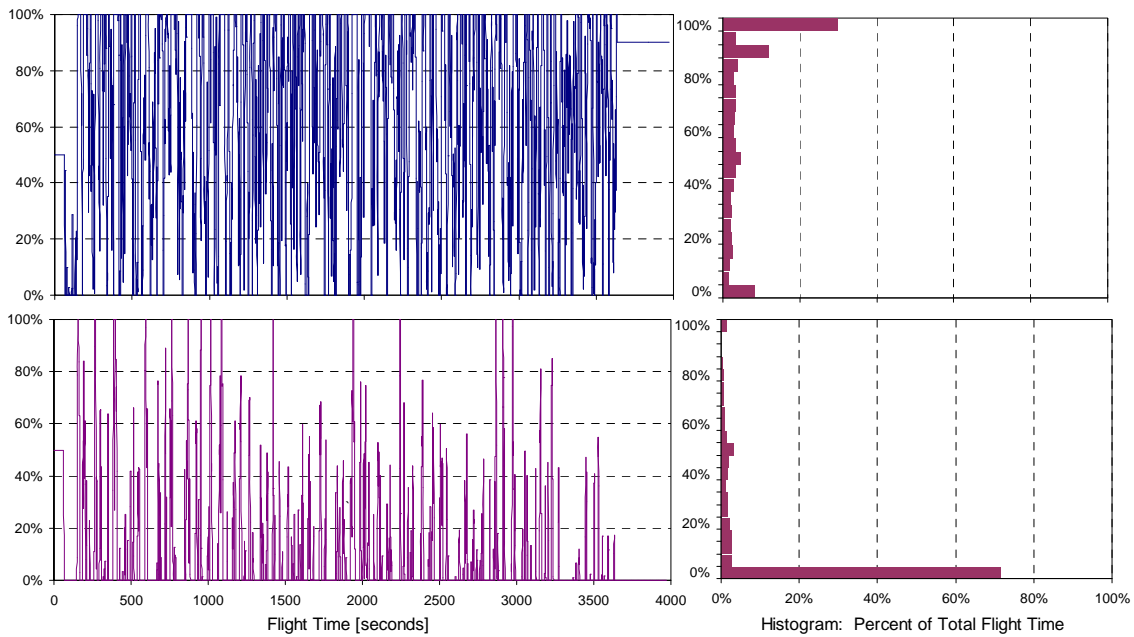

Figure 25. Thruster Duty Cycles for Severe Turbulence Conditions

7.0 OPERATIONAL PROCEDURES

7.1 PROPELLANT LOADING PROCEDURES

In preparation for airplane closeout prior to launch, a series of steps must be taken for propulsion system checkout and propellant preparation and handling. Since MMH and MON3 are hypergolic, the loading of each into the airplane must be separated by sufficient time to ensure the system is leak-proof, to avoid inadvertent mixing of propellant vapors or liquid. Table 11 outlines a typical bipropellant loading schedule leading to final airplane closeout.

Table 11. Airplane Propellant Loading Procedure

Activity	Schedule
Ground support equipment setup, staging and calibration	5 days
Final thruster functional tests (leak test and trace) Transducer calibration and Blanket Pressure Load of thruster tubing	2 days
Proof test Helium tank to 1.1 MEOP to ensure integrity	1 day
Pressurize Helium tank to Flight Pressure Final High Pressure leak check of Service Valves	½ - 1 day
MMH Loading: Sample MMH for testing and resample if necessary Measure flight quantity of MMH and load into fuel tank Closeout and Final Leak Check of Fuel Side	2 days ½ - 1 day ½ day ½ day
MON3 Loading: Sample MON3 for testing and resample if necessary Measure flight quantity of MON3 and load into oxidizer tank Closeout and Final Leak Check of Oxidizer Side	2 days ½ - 1 day ½ day ½ day
Install NASA Standard Initiators (NSI) onto pyrovalves	1 day
Final Closeout of Airplane	1 day
Total Propellant Loading Schedule	15 days

7.2 SYSTEM ACTIVATION SEQUENCE

The propulsion system is pressurized and activated at the end of the Entry, Descent, and Deployment sequence. Based on altitude at the completion of the pullout maneuver, the airplane determines when the propulsion system should be initiated. If it is determined that the altitude is higher than 2 km AGL, then the airplane continues to glide until reaching the 2 km threshold, at which time the propulsion activation sequence begins. The propulsion system is activated by first cycling the engine valves to evacuate the engine manifold and the lines downstream of the liquid-side pyrovalves (See Figure 5). Next, the liquid-side pyro-valves are fired followed by the gas-side pyrovalves. The propulsion system is pressurized by the firing of the high-pressure pyrovalve located on the helium tank, providing pressure to the propellant tanks, forcing liquid downstream to the thruster valves. Thrust is then controlled by actuating the individual valves on each thruster. This sequence prevents the propellant tanks from experiencing “slam-start” conditions when the gas-side pyrovalves are fired. The pressure regulator will experience a slam-start when the helium tank pyrovalve is fired, so the regulator will have to be tested and qualified for this operational condition.

7.3 COMPONENT QUALIFICATION REQUIREMENTS

Due to the cost and schedule constraints imposed by Mars Scout missions, hardware with significant flight heritage is preferred to minimize efforts in preparing such hardware for flight readiness. The only components of the propulsion system that require original design, development, and qualification are the propellant tanks and PMDs. The helium tank is based on a modified existing design and will undergo a delta-qualification. Thrusters and the helium regulator will also undergo a delta-qualification to characterize performance based on the unique operating conditions of the ARES airplane. The thruster will also be hot-fire tested to determine specific performance profiles based on expected ARES mixture ratios, duty cycles, and operating pressures. All propulsion hardware will endure a series of pressure tests, flow and leak checks, as well as environmental tests including vibration and shock. The component qualification matrix is shown in Table 12.

Table 12. Component Qualification Requirements

	Dev	Qual	ΔQual	Proof	Burst	Flow	Leak	Vib	Shock	ATP	Other
Propellant tanks											
PMDs											Bubble Point
GHe Tank											
Thrusters											Hot Fire
Helium Regulator											Set pt, slam start, lockup
Pres. Transducers											Calibration
Service Valves											
Check Valves											Lot acceptance test
Pyro valves											Lot acceptance test

Dev – Full development Required

Qual – Qualification Required

ΔQual - Certain design changes require re-qualification

Proof – Test components to 1.1 MEOP

Burst – Test components to structural failure

Flow – Test flowrates of propellants

Leak – Leak check fittings and components

Vib – Expose components to expected vibration levels and check performance

Shock – Expose components to expected g-levels and check performance

ATP – Acceptance testing

7.4 FERRIC NITRATE MITIGATION

The oxidizer, MON3 (nitrogen tetroxide with mixed oxides of nitrogen), reacts with stainless steel causing low levels of dissolved iron into the oxidizer. This reacts to form an iron nitrate complex, which can become quickly saturated, and solid particles may precipitate from the liquid during abrupt temperature and pressure changes¹¹. Sharp bends in propellant tubing or pressure drops caused by orifices or valve seats are areas prone to ferric nitrate precipitation. This precipitate can restrict flow by accumulating in components with small openings or orifices or may damage components containing moving parts with close tolerances, such as check valves or thruster valves.

The amount of precipitate that can form in a given location is proportional to the amount of oxidizer throughput past that point. Since the ARES mission is of short duration, using only 28 kg of MON3, compared to typically 100s of kilograms used during missions where Ferric Nitrate precipitation becomes a concern. Characterization and removal of ferric nitrate in the Space Shuttle primary reaction control system was addressed by Johnson Space center and White Sands Test Facility¹². Recommendations from this publication and how they impact the ARES project are shown in Table 13⁵.

Table 13. ARES Ferric Nitrate Mitigation Recommendations

Shuttle PRCS Recommendation	ARES Impact
Maximize the concentration of NO in oxidizer. NO has a fairly dramatic effect on the solubility of metal nitrate in oxidizer, so the NO concentration could be increased to a level that would ensure the oxidizer retained excellent hypergolic properties yet would allow metal nitrate concentrations to be as high as 5 ppm (or even higher) without precipitation under usage conditions.	MON-3 Is Proposed for ARES, Relatively High NO concentration
Use “point-of-use” metal nitrate filters to minimize the metal nitrate in nitrogen tetroxide during loading at the launch facility. The molecular sieve, developed at WSTF and used by the oxidizer supplier, is typically 0.2 ppm or less in metal nitrate concentration at tank truck loading. Ensuring that a minimum metal nitrate concentration is initially loaded into the orbiters will increase the possibility for avoiding the saturation point.	ARES will use highly filtered N2O4 (MON3) and sample to ensure a low initial concentration ARES will maintain tank temps above 0°C for Cruise. ~ 1 day pre-entry increase tank temps to above 27°C. Raises the precipitation point
Ensure that RCS valve temperatures do not drop below the saturation temperature (around 27°C) during all operations including orbiter ferrying. Allowing the temperature of the oxidizer to drop below the saturation point should be avoided under all circumstances. WSTF testing has shown that the precipitation point of metal nitrate is proportional to temperature, dropping to below the 1.5 ppm metal nitrate level for specification grade oxidizer at around 60°F	Heaters can be used to maintain valve temperatures before ARES propulsion operation begins.
Better understanding of the basic (kinetic) chemical reactions occurring to produce metal nitrate. Water intrusion with subsequent nitric acid formation is thought to be the major cause for corrosion, yet no proof or rate of reaction data has been established. Minimizing water intrusion (by using the universal throat plug and better handling techniques) and leaving systems wetted with nitrogen tetroxide (not water!) should help reduce corrosion.	An all-welded system leak tight to 10 ⁻⁶ scc/hr GHe external leak rate will preclude water entry.

8.0 ACKNOWLEDGEMENTS

The author would like to acknowledge and thank the following individuals for their contributions to the maturation of the Mars airplane propulsion system concept; Anthony J. Colozza (Analex Corporation, NASA GRC), Carl S. Guernsey (NASA JPL), and Henry S. Wright (NASA LaRC) for initial concept development and baseline propulsion system design. Mike McGee, Greg McAllister, Tim Fischer, and Carey Parish (Lockheed Martin) for in-depth propulsion system trade studies, propellant tank designs, PMD design, and overall system maturation. P. Sean Kenney (NASA LaRC) for flight simulation and propulsion system performance, Steven S. Gayle and David A. Paddock (NASA LaRC) for mechanical design and thruster mounting concept, Joseph Gasbarre and Salvatore Scola (NASA LaRC) for thruster thermal analyses, and Craig A. Hunter (NASA LaRC) for thruster plume CFD and aero-propulsion simulation.

9.0 ACRONYMS

AFS	Atmospheric Flight System
AGL	Above Ground Level
ARES	Aerial Regional-scale Environmental Survey
C&DH	Command and Data Handling
CFD	Computational Fluid Dynamics
COPV	Composite Over-wrapped Pressure Vessel
EELV	Evolved Expendable Launch Vehicle
GHe	Gaseous Helium
GRC	Glenn Research Center
GSFC	Goddard Space Flight Center
JPL	Jet Propulsion Laboratory
LaRC	Langley Research Center
LaSRS	Langley Standard Real-Time Simulation
MEOP	Maximum Expected Operating Pressure
MGS	Mars Global Surveyor
MMH	Monomethyl Hydrazine
MON3	Nitrogen Tetroxide with 3% Mixed Oxides of Nitrogen
MRO	Mars Reconnaissance Orbiter
NO	Mixed Oxide of Nitrogen
PAB3d	NASA Langley 3-dimensional CFD code
PCA	Propulsion Control Assembly
PIA	Propulsion Isolation Assembly
PMD	Propellant Management Device
PPM	Parts per million
SMACI	State of Health Monitoring & Attitude Control
STA	Science Target Area
TCM	Trajectory Correction Maneuver
TDB	To Be Determined
THAAD	Theater High-Altitude Area Defense\
TRL	Technology Readiness Level
WSTF	White Sands Test Facility

10.0 REFERENCES

1. “ARES, an Aerial Regional-scale Environmental Survey of Mars,” proposed in response to the NASA Office of Space Science Announcement of Opportunity NNH06ZDA002O for Mars Scout 2006 Missions, July 21, 2006.
2. “Comparison of Mars Aircraft Propulsion Systems,” Colozza, A.J., NASA CR-2003-212350, May 2003.
3. “Liquid Rocket Propulsion for Atmospheric Flight in the Proposed ARES Mars Scout Mission,” C. Kuhl, H. Wright, C. Hunter, NASA Langley Research Center, Hampton, VA; C. Guernsey, Jet Propulsion Laboratory, Pasadena, CA; A. Colozza, NASA Glenn Research Center, Cleveland, OH; AIAA-2004-3696. 40th AIAA/ASME/SAE/ASEE Joint Propulsion Conference and Exhibit, Fort Lauderdale, Florida, July 11-14, 2004.
4. Reed, R.D. (1978), “High-Flying Mini-Sniffer RPV: Mars Bound,” *Astronautics and Aeronautics*, Vol. 16, No. 6, pp 26-39.
5. “Mars Airplane Propulsion Study – Final Report,” NASA Contract NAS1-00141, Lockheed Martin Astronautics, April 19, 2005.
6. “ARES, an Aerial Regional-scale Environmental Survey of Mars – Concept Study Report,” proposed in response to the NASA Office of Space Science Announcement of Opportunity AO 02-OSS-02 for Mars Scout investigations, April 30, 2003.
7. “Trade study of multiple thruster options for the Mars Airplane concept,” Kuhl, C.A., Gayle, S.W., Hunter, C.A., Kenney, P.S., Scola, S., Paddock, D.A., Wright, H.S., Gasbarre, J.F., NASA TM-2009-215699. March 2009.
8. “Long Life 5 LBF Bipropellant Engines,” AIAA-85-1378, Chazen, M.L., Bell Aerospace Textron, AIAA/SAE/ASME/ASEE 21st Joint Propulsion Conference, Monterey, California, July 8-10, 1985.
9. “Transient thermal model of a film-cooled bipropellant thruster,” G. P. Purohit, P. A. Donatelli, J. R. Ellison (Hughes Space and Communications Co., El Segundo, CA), and V. K. Dhir (California, Univ., Los Angeles), AIAA-2000-1071, Aerospace Sciences Meeting and Exhibit, 38th, Reno, NV, Jan. 10-13, 2000.
10. “Simulating the ARES Aircraft in the Mars Environment,” Kenney, P.S., AIAA-2003-6579, 2nd AIAA “Unmanned Unlimited” Systems, Technologies, and Operations – Aerospace Conference, San Diego, California, September 15-18, 2003.
11. “Investigation of iron nitrate solubility in nitrogen tetroxide oxidizers”, MELLOR, B.SMITH, C. L. (Royal Ordnance, PLC, Westcott, United Kingdom) KAELSCH, I. (ESTEC, Noordwijk, Netherlands) AIAA-1992-3610 SAE, ASME, and ASEE, Joint Propulsion Conference and Exhibit, 28th, Nashville, TN, July 6-8, 1992. 13 p.
12. “Space Shuttle reaction control system thruster metal nitrate removal and characterization,” Saulsberry, R. L.; McCartney, P. A., National Aeronautics and Space Administration. White Sands Test Facility, NM. The 1993 JANNAF Propulsion Meeting, Volume 2 p 103-113 (SEE N95-16324 04-20), November 1993.

REPORT DOCUMENTATION PAGE				Form Approved OMB No. 0704-0188	
<p>The public reporting burden for this collection of information is estimated to average 1 hour per response, including the time for reviewing instructions, searching existing data sources, gathering and maintaining the data needed, and completing and reviewing the collection of information. Send comments regarding this burden estimate or any other aspect of this collection of information, including suggestions for reducing this burden, to Department of Defense, Washington Headquarters Services, Directorate for Information Operations and Reports (0704-0188), 1215 Jefferson Davis Highway, Suite 1204, Arlington, VA 22202-4302. Respondents should be aware that notwithstanding any other provision of law, no person shall be subject to any penalty for failing to comply with a collection of information if it does not display a currently valid OMB control number.</p> <p>PLEASE DO NOT RETURN YOUR FORM TO THE ABOVE ADDRESS.</p>					
1. REPORT DATE (DD-MM-YYYY) 01-03-2009		2. REPORT TYPE Technical Memorandum		3. DATES COVERED (From - To)	
4. TITLE AND SUBTITLE Design of a Mars Airplane Propulsion System for the Aerial Regional-Scale Environmental Survey (ARES) Mission Concept				5a. CONTRACT NUMBER	
				5b. GRANT NUMBER	
				5c. PROGRAM ELEMENT NUMBER	
6. AUTHOR(S) Kuhl, Christopher A.				5d. PROJECT NUMBER	
				5e. TASK NUMBER	
				5f. WORK UNIT NUMBER 698671.02.07.02.01	
7. PERFORMING ORGANIZATION NAME(S) AND ADDRESS(ES) NASA Langley Research Center Hampton, VA 23681-2199				8. PERFORMING ORGANIZATION REPORT NUMBER L-19388	
9. SPONSORING/MONITORING AGENCY NAME(S) AND ADDRESS(ES) National Aeronautics and Space Administration Washington, DC 20546-0001				10. SPONSOR/MONITOR'S ACRONYM(S) NASA	
				11. SPONSOR/MONITOR'S REPORT NUMBER(S) NASA/TM-2009-215700	
12. DISTRIBUTION/AVAILABILITY STATEMENT Unclassified - Unlimited Subject Category 20 Availability: NASA CASI (443) 757-5802					
13. SUPPLEMENTARY NOTES					
14. ABSTRACT The Aerial Regional-Scale Environmental Survey (ARES) is a Mars exploration mission concept with the goal of taking scientific measurements of the atmosphere, surface, and subsurface of Mars by using an airplane as the payload platform. ARES team first conducted a Phase-A study for a 2007 launch opportunity, which was completed in May 2003. Following this study, significant efforts were undertaken to reduce the risk of the atmospheric flight system, under the NASA Langley Planetary Airplane Risk Reduction Project. The concept was then proposed to the Mars Scout program in 2006 for a 2011 launch opportunity. This paper summarizes the design and development of the ARES airplane propulsion subsystem beginning with the inception of the ARES project in 2002 through the submittal of the Mars Scout proposal in July 2006.					
15. SUBJECT TERMS Mars; Airplane; Bipropellant; Propulsion; Rocket					
16. SECURITY CLASSIFICATION OF:			17. LIMITATION OF ABSTRACT	18. NUMBER OF PAGES	19a. NAME OF RESPONSIBLE PERSON
a. REPORT	b. ABSTRACT	c. THIS PAGE			STI Help Desk (email: help@sti.nasa.gov)
U	U	U	UU	38	19b. TELEPHONE NUMBER (Include area code) (443) 757-5802