

Ares I-X Flight Test—The Future Begins Here

*Stephan R. Davis, Deputy Manager, Flight Test Vehicle
Ares I-X Mission Management Office
NASA Marshall Space Flight Center
Huntsville, AL 35812*

Abstract

In less than two years, the National Aeronautics and Space Administration (NASA) will launch the Ares I-X mission. This will be the first flight of the Ares I crew launch vehicle, which, together with the Ares V cargo launch vehicle, will eventually send humans to the Moon, Mars, and beyond. As the countdown to this first Ares mission continues, personnel from across the Ares I-X Mission Management Office (MMO) are finalizing designs and fabricating vehicle hardware for an April 2009 launch. This paper will discuss the hardware and programmatic progress of the Ares I-X mission.

Like the Apollo program, the Ares launch vehicles will rely upon extensive ground, flight, and orbital testing before sending the Orion crew exploration vehicle into space with humans on board. The first flight of Ares I, designated Ares I-X, will be a suborbital development flight test. Ares I-X gives NASA its first opportunity to gather critical data about the flight dynamics of the integrated launch vehicle stack; understand how to control its roll during flight; better characterize the severe stage separation environments that the upper stage engine will experience during future operational flights; and demonstrate the first stage recovery system. NASA also will begin modifying the launch infrastructure and fine-tuning ground and mission operations, as the agency makes the transition from the Space Shuttle to the Ares/Orion system.



Figure 1. The Ares I-X Flight Test Vehicle incorporates both flight-like and mass simulator hardware.

The Ares I-X Flight Test Vehicle (FTV) will incorporate a mix of flight and mockup hardware, reflecting a configuration similar in mass and weight to the operational vehicle. It will be powered by a four-segment Solid Rocket Booster (SRB), which is currently in Shuttle inventory, and will be modified to include a fifth spacer segment that makes the booster approximately the same size and weight as the five-segment SRB.

The Ares I-X flight profile will closely approximate the flight conditions that the Ares I will experience through Mach 4.5, at an altitude of about 130,000 feet and through maximum dynamic pressure (“Max Q”) of approximately 800 pounds per square foot. Basing vehicle design refinements on Ares I-X information puts NASA one step closer to full-up “test as you fly” scenarios. Each future flight will be staged to affect future milestone reviews. Ares I-X supports the Ares I Critical Design Review (CDR).

Work continues on Ares I-X design and hardware fabrication. All of the individual elements are undergoing CDRs, which will be followed by an integrated vehicle CDR in March 2008. The various hardware elements are on schedule to begin deliveries to Kennedy Space Center (KSC) in the August-September 2008 timeframe.

First Stage (FS)

Using a four-segment SRB available from the Space Shuttle inventory, the FS team is building the new forward structures that connect the booster to the Upper Stage Simulator (USS). These structures—the Forward Skirt, Forward Skirt Extension, Aeroshell, Frustum, and Interstage—are high-durability “battleship” hardware. The First Stage’s CDR occurs in mid-January 2008.

Upper Stage Simulator (USS)

The USS is being designed and built at Glenn Research Center (GRC) in Ohio. Because of GRC’s limited high-bay space and the need to transport the flight hardware by barge, the USS is being built in a series of 11 smaller “tuna can” segments, which will be stacked and integrated at KSC. The USS CDR will occur February 2008.

Roll Control System (RoCS)

As the FTV flies upward, it will tend to roll around its direction of forward motion. To counteract this, the FTV will have an active RoCS on the interstage to keep the vehicle from rolling. The RoCS also initiates a 90-degree roll soon after liftoff to properly orient the FTV for flight. To handle this pulsing duty cycle, the MMO is using axial engines harvested from Peacekeeper missiles that were due to be decommissioned and destroyed as part of an arms control agreement. The MMO has harvested five sets of fuel tanks and engines, which will be used for duty cycle testing at White Sands Testing Facility, tanking and de-tanking tests at KSC, and flight testing. The RoCS completed its CDR in December 2007.

Avionics

The Ares I-X avionics hardware is already undergoing development and testing by using a combination of avionics components from the Atlas V Evolved Expendable Launch Vehicle (EELV) and heritage Shuttle systems. The avionics team is starting to map out the physical location and arrangement of the controller boxes, as well as cabling within the FTV. The work receiving the most attention is the Ascent Thrust Vector Controller (ATVC) system, which acts as a translation tool between the avionics from a liquid fuel rocket and the solid-fuel SRB. The Avionics CDR was completed in December 2007.

Command Module/Launch Abort System (CM/LAS) Simulator

Because Ares I-X is a test of the Ares launch vehicle only, there will be no Orion payload onboard. Instead, the CM, Service Module, Spacecraft Adapter, and LAS will be mass simulator hardware that reflects the same outer mold line as the operational Ares I vehicle. There have been changes to the shape of the Ares I since the Ares I-X design was established. As a result, the CM/LAS simulator might not totally replicate the current design. However, sensors on the forward structures will enable Ares Projects Office (APO) engineers to obtain accurate information about aerodynamic and acoustic loads in an Ares I-like flight environment. The CM/LAS CDR is scheduled for March 2008.

Summary

Ares I-X is the first step in the long journey back to the Moon and on to farther destinations. This suborbital test will be NASA’s first flight of a new human-rated launch vehicle in more than a generation. The Ares I-X MMO team is well on its way toward completing the vehicle’s design and hardware fabrication in time for an April 2009 launch. This promises to be an exciting time for NASA and the nation, as we reach for new goals in space exploration.

Nomenclature

<i>AIT</i>	= Assembly, Integration, and Test	<i>LaRC</i>	= Langley Research Center
<i>APO</i>	= Ares Projects Office	<i>LAS</i>	= Launch Abort System
<i>ATVC</i>	= Ascent Thrust Vector Controller	<i>LEO</i>	= Low Earth Orbit
<i>BDM</i>	= Booster Deceleration Motor	<i>LH₂</i>	= Liquid Hydrogen
<i>CDR</i>	= Critical Design Review	<i>LOX</i>	= Liquid Oxygen
<i>CM</i>	= Crew Module	<i>MLP</i>	= Mobile Launch Platform
<i>CoFR</i>	= Certificate of Flight Readiness	<i>MMO</i>	= Mission Management Office
<i>COTS</i>	= Commercial Off The Shelf	<i>MPSS</i>	= Main Parachute Support System
<i>CxP</i>	= Constellation Program	<i>MSFC</i>	= Marshall Space Flight Center
<i>DFI</i>	= Developmental Flight Instrumentation	<i>MVAN</i>	= Multipurpose Van
<i>EELV</i>	= Evolved Expendable Launch Vehicle	<i>NASA</i>	= National Aeronautics and Space Administration
<i>FITO</i>	= Flight and Integrated Test Office	<i>RoCS</i>	= Roll Control System
<i>FS</i>	= First Stage	<i>S&MA</i>	= Safety and Mission Assurance
<i>FTV</i>	= Flight Test Vehicle	<i>SE&I</i>	= Systems Engineering and Integration
<i>GN&C</i>	= Guidance, Navigation, and Control	<i>SIL</i>	= Systems Integration Laboratory
<i>GO</i>	= Ground Operations	<i>SM</i>	= Service Module
<i>GRC</i>	= Glenn Research Center	<i>SRB</i>	= Solid Rocket Booster
<i>GS</i>	= Ground Systems	<i>TLI</i>	= Trans-Lunar Injection
<i>HMF</i>	= Hypergolic Maintenance Facility	<i>TVC</i>	= Thrust Vector Control
<i>IDA</i>	= Integrated Design and Analysis	<i>USS</i>	= Upper Stage Simulator
<i>ISS</i>	= International Space Station	<i>VAB</i>	= Vehicle Assembly Building
<i>JSF</i>	= Joint Strike Fighter		
<i>KSC</i>	= Kennedy Space Center		

Ares I-X Flight Test—The Future Begins Here

Stephan R. Davis¹

Marshall Space Flight Center, Huntsville, AL 35824

[Abstract] In less than two years, the National Aeronautics and Space Administration (NASA) will launch the Ares I-X mission. This will be the first flight of the Ares I crew launch vehicle, which, together with the Ares V cargo launch vehicle, will eventually send humans to the Moon, Mars, and beyond. As the countdown to this first Ares mission continues, personnel from across the Ares I-X Mission Management Office (MMO) are finalizing designs and fabricating vehicle hardware for a 2009 launch. This paper will discuss the hardware and programmatic progress of the Ares I-X mission.

Nomenclature

5SS	=	Fifth Segment Simulator	K lb.	=	Thousands of Pounds
AIT	=	Assembly, Integration, and Test	KSC	=	Kennedy Space Center
ARF	=	Assembly and Refurbishment Facility	LaRC	=	Langley Research Center
ATVC	=	Ascent Thrust Vector Controller	LC	=	Launch Complex
BDM	=	Booster Deceleration Motor	MLP	=	Mobile Launch Platform
BTM	=	Booster Tumble Motor	MMO	=	Mission Management Office
CDR	=	Critical Design Review	MPSS	=	Main Parachute Support System
CG	=	Center of Gravity	MSFC	=	Marshall Space Flight Center
CM/LAS	=	Crew Module/Launch Abort System	NASA	=	National Aeronautics and Space Administration
DAC	=	Design Analysis Cycle	nm	=	Nautical Miles
DFI	=	Developmental Flight Instrumentation	OFI	=	Operational Flight Instrumentation
ECS	=	Environmental Control System	OML	=	Outer Mold Line
EELV	=	Evolved Expendable Launch Vehicle	RoCS	=	Roll Control System
FS	=	First Stage	RPSF	=	Rotation, Processing, and Surge Facility
FSAM	=	First Stage Avionics Module	secs	=	Seconds
FTINU	=	Fault Tolerant Inertial Navigation Unit	SDA	=	Solid Rocket Booster-Derived Avionics
FTS	=	Flight Termination System	SIL	=	Systems Integration Laboratory
FTV	=	Flight Test Vehicle	SRB	=	Solid Rocket Booster
GN&C	=	Guidance, Navigation, and Control	TRR	=	Test Readiness Review
GO	=	Ground Operations	TTR	=	Table Top Review
GS	=	Ground Systems	ULA	=	United Launch Alliance
GSE	=	Ground Support Equipment	USS	=	Upper Stage Simulator
HMF	=	Hypergol Maintenance Facility	VAB	=	Vehicle Assembly Building
IS	=	Interstage			
K ft.	=	Thousands of Feet			

I. Introduction

IN less than a year, the National Aeronautics and Space Administration (NASA) will launch the Ares I-X mission. This will be the first flight of the Ares I crew launch vehicle, which, together with the Ares V cargo launch vehicle, will eventually send humans to the Moon, Mars, and beyond. As the countdown to this first Ares mission continues, personnel from across the Ares I-X Mission Management Office (MMO) are finalizing designs and fabricating vehicle hardware for a 2009 launch. This paper will discuss the hardware and programmatic progress of the mission to date.

NASA is committed to executing the U.S. Space Exploration Policy, first announced in 2004, which tasked the agency to complete the International Space Station, retire the Space Shuttle, and develop new launch vehicles capable of providing human access to low-Earth orbit, the Moon, and other destinations. The Ares Projects, based at Marshall Space Flight Center (MSFC) in Huntsville, Alabama, are responsible for building the Ares I crew launch

¹ Deputy Mission Manager, Ares I-X Mission Management Office, Bldg. 4203, Rm. 6300, AIAA Senior Member.

vehicle and Ares V cargo launch vehicle to fulfill this new, ambitious mission (Figure 1). The first test flight of Ares I is being conducted by the Ares I-X Mission Management Office in 2009.



Figure 1. Ares V (left) and Ares I (right) will be America's premier exploration vehicles for the next generation.

Like the Apollo program, the Ares launch vehicles will rely upon ground, flight, and orbital testing before sending the Orion crew exploration vehicle into space with astronauts on board. The first flight of Ares I, designated Ares I-X, will closely resemble the Saturn I launch vehicle tests, in that it will be a suborbital development flight test (Figure 2).



Figure 2. Ares I-X (right) follows NASA's tradition of incremental development through flight testing, which has included the Mercury, Gemini, and Saturn programs (left).

II. Mission Overview

The Ares I-X Flight Test Vehicle (FTV) will incorporate a mix of flight and mockup hardware (Figure 3), reflecting a configuration similar in mass and weight to the operational Ares I. It will be powered by a four-segment solid rocket motor, which is currently in Shuttle inventory, and will be modified to include a fifth spacer segment that makes the booster approximately the same size and weight as the five-segment SRB. The vehicle also features a new recovery system, including new main parachutes. The new main chutes are 150 feet across, compared to 136 feet across for the Shuttle. Ares I-X will be the first flight test of new main parachutes for Ares I.

The Ares I-X flight profile will closely approximate the flight conditions that Ares I will experience through Mach 4.5, at an altitude of about 130,000 feet and through a maximum dynamic pressure ("Max Q") of approximately 800 pounds per square foot (Figure 4). By basing refinements of the Ares I vehicle design on Ares I-X information, NASA moves one step closer to full-up "test as you fly" scenarios. Each future flight will be staged to affect future milestone reviews. Ares I-X supports the Ares I Critical Design Review (CDR), scheduled for 2010.

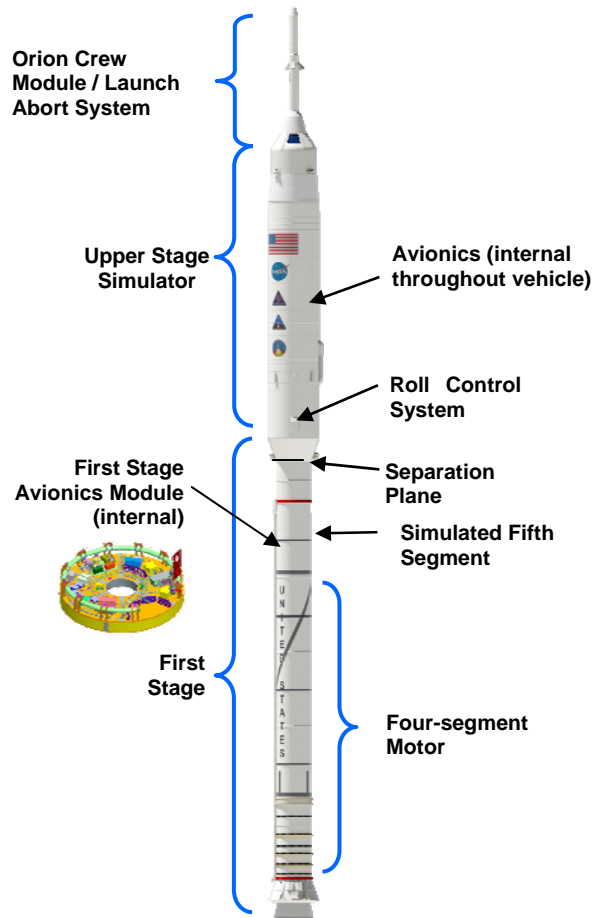

Figure 3. The Ares I-X provides an early opportunity to test the flight configuration of the Ares I crew launch vehicle.

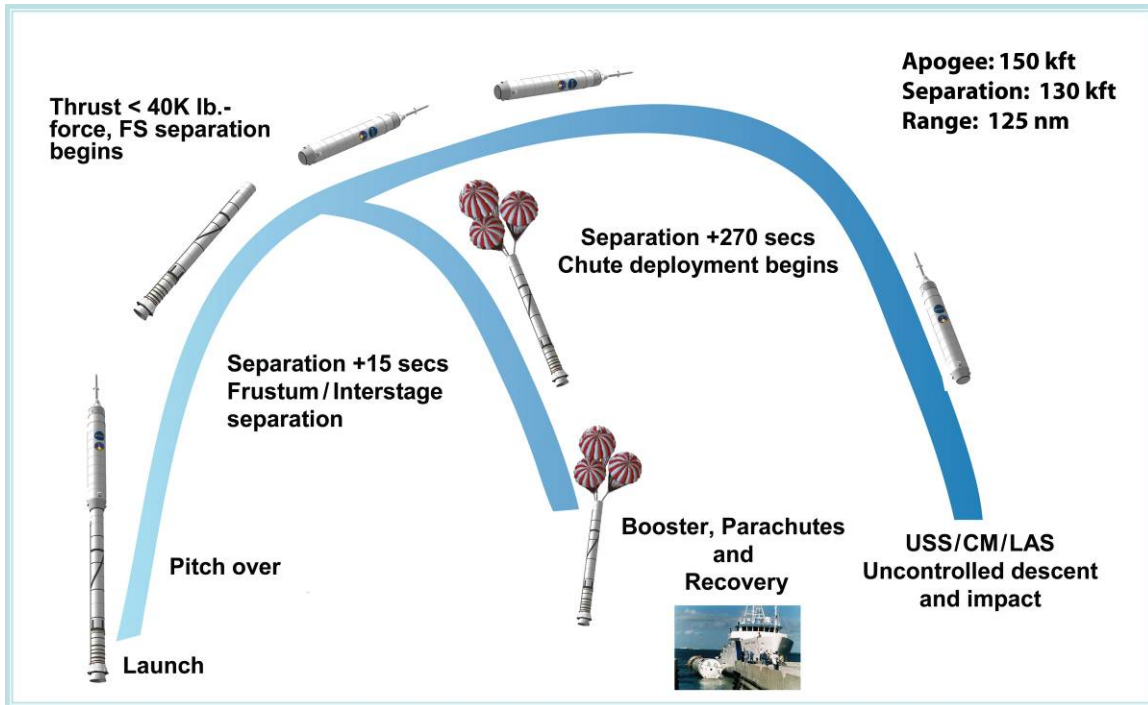

Figure 4. The Ares I-X flight profile closely resembles the uncrewed Saturn I flights of the 1960s.

The Ares I-X mission will be NASA's first flight test of a new human exploration vehicle since 1981. As such, it returns the agency to its history as a pioneering organization, taking on technical risks to develop new space hardware. The five primary test objectives for the Ares I-X flight test include:

- Demonstrating the ascent flight control system performance with dynamically similar hardware.
- Demonstrating nominal first and upper stage separation and clearances.
- Characterizing and mitigating the roll torque due to first stage (FS) motor performance.
- Testing the first stage parachute recovery system and separation/entry dynamics.
- Validating assembly and processing flow, as well as launch and recovery operations.

These objectives are all attainable using a combination of existing flight hardware and simulator hardware equipped with environmental, acceleration, and other sensors.

Ares I-X also provides the first opportunity to test new assembly, integration, and test (AIT) functions at Kennedy Space Center (KSC). When vehicle elements begin arriving at KSC by October 2008, they will be moved to the Assembly and Refurbishment Facility (ARF), where developmental flight instrumentation (DFI) will be integrated and the upper stage simulator (USS) segments will be stacked in smaller "super stacks" to support final assembly of the vehicle in the Vehicle Assembly Building (VAB).

The vehicle will be launched from KSC Launch Complex (LC) 39B, which will be used as a backup launch-on-demand facility for the Shuttle during the servicing mission (STS-125) in August 2008. Once STS-125 is completed, LC 39B will be transferred to the Ares Projects for use on the flight test. Because of its Shuttle-ready state, LC 39B will need to be modified slightly to support Ares I-X until a full tear-down and redesign of the complex can be begun in 2010. Additional vehicle interfaces and a sway damper will be added to the Mobile Launch Platform (MLP) to accommodate the much taller Ares I-X vehicle, which is 325 feet tall, as opposed to the Shuttle, which stands 184 feet tall. In addition, the Ares I-X upper stage simulator (USS) will include a series of interior stairs, ladders, and ring-shaped platforms to allow Ground Operations personnel to access the inside of the vehicle prior to launch. The ground support systems also include an environmental control system (ECS) to keep the avionics and ground staff cool prior to liftoff. The ECS will have a T-0 disconnect connection between the ground systems and the Flight Test Vehicle (FTV), which remains intact until the first stage ignition command (T-0) is issued.

Work continues on Ares I-X design and hardware fabrication. All of the individual elements are undergoing or have completed CDRs, which was followed by a two-part integrated vehicle CDR in March and July 2008. The various hardware elements are on schedule to begin deliveries to KSC by October 2008.

III. Progress on Mission Hardware and Facilities.

The Ares I-X mission was authorized to proceed in spring 2006. Given its rapid development cycle, hardware design and manufacturing have occurred nearly simultaneously to meet the launch date. Thus, while the CDR began in March 2008, much of the flight hardware was already well through the fabrication process.

A. First Stage

As noted earlier, the first stage (Figure 5) is using a four-segment solid rocket motor from the Shuttle inventory. New forward structures are being manufactured, as are the segments of the USS. These new structures will be heavier than the Ares I hardware and will be made mostly of steel. The frustum and aeroshell on the operational Ares I will not be reused and will be made of carbon composites. The Ares I forward skirt and forward skirt extension will be made of aluminum.

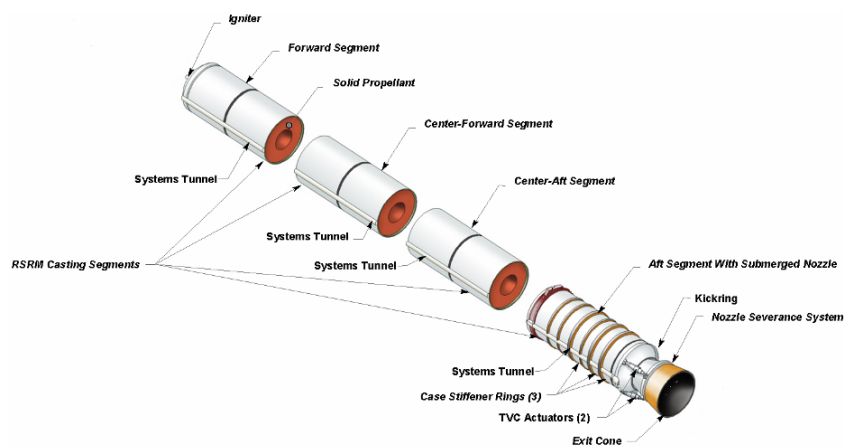

Figure 5. Reusable Solid Rocket Motor details.

Frustum—The frustum connects the first stage to the upper stage. Machining on the frustum was completed in June 2008.

Forward Skirt Extension—The forward skirt extension, which houses the pilot and drogue parachutes, is scheduled to be delivered to the ARF in late July 2008. The Ares I-X separation plane will be between the frustum and the forward skirt extension (Figure 6). A field test of the separation system was conducted at ATK’s Promontory site in July 2008.

Forward Skirt—The forward skirt, housing the Main Parachute Support System (MPSS), is due to be delivered to the ARF in late July 2008.

5th Segment Simulator (5SS)—The structure of the fifth segment simulator (also called 5SS, the spacer segment, or the XL segment) is 10 percent complete. The 5SS (Figure 7) houses the primary avionics module for Ares I-X, the First Stage Avionics Module (FSAM), the Flight Termination System (FTS), and other components. The first of the 5SS components arrives at the ARF in July 2008, with additional sections delivered in August.



Figure 6. The test of the forward skirt extension’s separation system verified the effectiveness of the linear shaped charge and its shock effects.

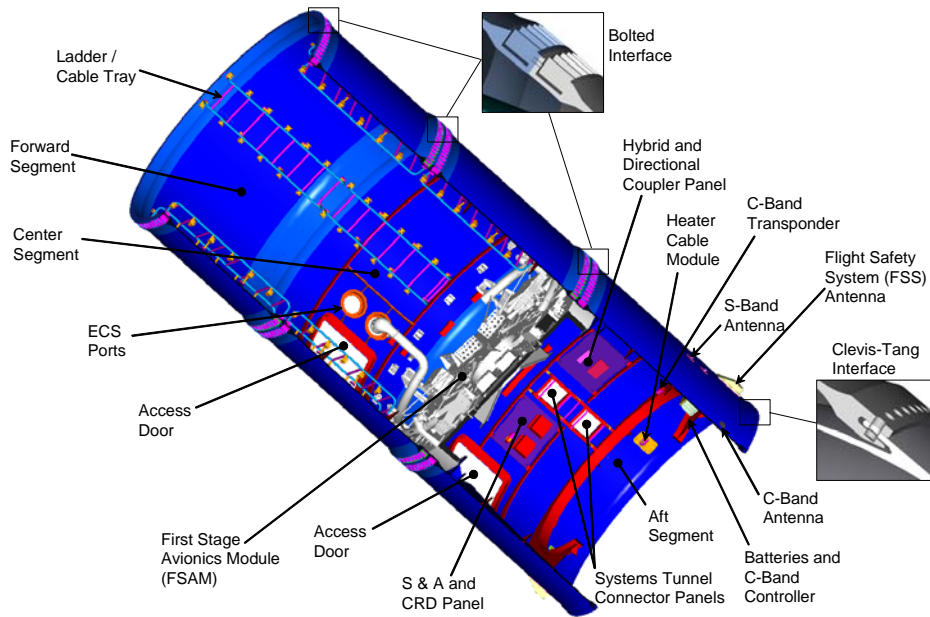

Figure 7. This computer-generated interior view of the 5th Segment Simulator shows avionic components and access interfaces.

Motor Segments—The motor segments are currently in the ARF, undergoing installation of DFI and thermal protection systems (TPS). They are scheduled to be transferred from the ARF to the Rotation, Processing, and Surge Facility (RPSF) at KSC in October 2008.

Aft Skirt—The aft skirt (Figure 8), like the motor segments, uses existing Shuttle hardware. The Ground Systems team at KSC is removing the TPS in the ARF so that additional ballast, booster deceleration motors (BDMs), and booster tumble motors (BTMs) can be installed. The aft skirt for Ares I-X, when operational, will include eight BDMs and four BTMs. A recent “lean event” at KSC helped increase the schedule margin for the skirt, resulting in a delivery to the RPSF by as much as one month earlier than originally scheduled. The aft skirt is currently scheduled to be delivered to the RPSF in October 2008.

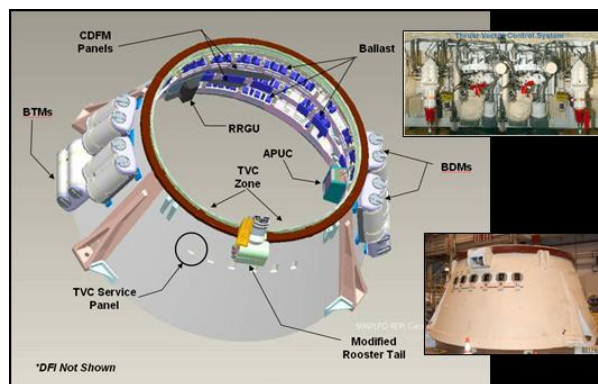

Figure 8. The aft skirt, while Shuttle-legacy hardware, will have hardware added to meet the requirements of Ares I-X.

Separation and Deceleration—Five successful drop tests of the parachute system (Figure 9) have been completed so far. Two additional tests are planned before April 2009. Ares I-X will be the first qualification flight test of the new 150-foot-diameter main parachutes.



Figure 9. The main parachutes are in the process of fabrication and drop testing.

B. Avionics

Ares I-X will carry four types of avionics hardware:

- Guidance, navigation, and control (GN&C) avionics from the Atlas V Evolved Expendable Launch Vehicle (EELV)
- Solid Rocket Booster-derived avionics (SDA) for controlling most of the first stage functions
- A new component, the ascent thrust vector controller (ATVC), which translates commands between the Atlas V components and the solid-propellant first stage
- Developmental Flight Instrumentation (DFI) and Operational Flight Instrumentation (OFI)

For Ares I, the majority of the first stage avionics will be housed in the instrument unit and forward skirt. For Ares I-X, most of the avionics will be located on the First Stage Avionics Module (FSAM). Like the other pieces of Ares I-X hardware, the avionics components are making great progress toward the 2009 launch date. The table below lists the activities and delivery dates for the avionics.

Component(s)	Current Status (As Appropriate)	Anticipated Completion/Delivery
ATVC	CDR completed June 2007 Fabrication under way	October 2008
FSAM	CDR completed April 2008	October 2008
Flight Software	CDR completed March 2008 Test Readiness Review completed April 2008	March 2009
Ground Software (Ground Control, Command, and Communications/GC3)	Formal testing under way	Delivery to KSC October 2008 Installation in MLP by May 2009
Systems Integration Laboratory Vehicle Flight Control Testing Flight Simulation Testing	Ongoing Ongoing	October 2008 May 2009
OFI / DFI Sensors and Harnesses	Sensors acquired or on order Undergoing Table Top Reviews as completed	<i>Cable Harnesses</i> CM/LAS July 2008 USS October 2008 FS October 2008 <i>OFI Harnesses</i> FS/USS October 2008
Fault Tolerant Inertial Navigation Unit (FTINU)	Qualification testing complete Delivered to United Launch Alliance in March 2008	Delivery to KSC March 2009
SDA	Fabrication begun December 2007	August 2008

C. Upper Stage Simulator (USS)

The USS (Figure 10) is made up of cylindrical segments that will be stacked and integrated at KSC for launch. Glenn Research Center is completing the assembly of these segments, along with their internal structures (Figure 11).

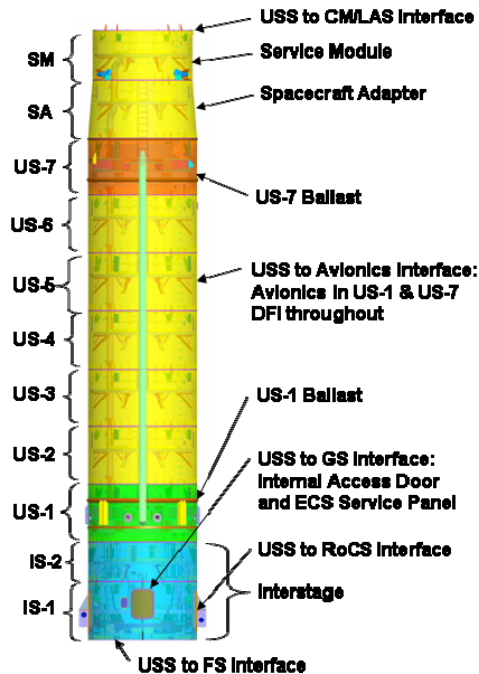

Figure 10. This engineering diagram depicts the order and sizes of the USS segments.



Figure 11. This image shows the interior of the USS

The USS is a mass simulator. It provides the majority of adjustable ballast for the vehicle’s mass, center of gravity (CG), and moment of inertia distribution. The 2-inch-thick ballast plates are approximately 7,000 pounds (lbs.) each. The US-1 segment holds 16 plates \pm 2 plates equaling approximately 112,000 lbs. The US-7 segment holds 5 plates \pm 2 plates, weighing approximately 35,000 lbs. The total adjustable ballast is around 147,000 lbs.

The USS is designed with 11 segments: 5 *common* segments (US-2, 3, 4, 5, 6), 2 adjustable ballast segments (US-1 and 7), and 4 *complex* segments (Interstage (IS)-1 and IS-2, Spacecraft Adapter (SA), and Service Module (SM)).

Each segment (Figure 13) is approximately 9.5 feet tall to accommodate manufacturing and transportation constraints. Outer Mold Line (OML) protuberances are all bolted on and assembled on individual segments prior to shipping except the Ullage Motors (4x) and Roll Control System (RoCS) Modules (2x) located on the US-1 segment, which will be shipped separately. An internal access door on US-1 and platforms and ladders provide access to the entire USS, the FS Frustum, and CM/LAS.

USS has successfully completed three Critical Design Reviews, which were ordered by segment complexity, with the “Charge 1” segments being the least complex and “Charge 3” being the most complex, incorporating the Roll Control System and avionics. Charge 1 hardware has already been fabricated. Charge 2 is underway to be completed per schedule. Charge 3 hardware fabrication has been started. Manufacturing processes and procedures have been successfully demonstrated.

The environmental control system (ECS) used in the VAB and at the launch platform will provide air circulation for the confined space as well as providing a dry humidity free environment for the avionics and DFI. The ECS Service Panel is located next to the Internal Access Door in IS-1, where a 14-inch diameter duct is routed from IS-1 to the SM. All ductwork is assembled in each segment at GRC before shipping to KSC.

D. Roll Control System (RoCS)

The active roll control system (RoCS) provides rotational azimuth control to perform a 90-degree roll orientation maneuver after liftoff and to mitigate against adverse roll torques (self- and aero-induced) during ascent. The number of RoCS pulses used to overcome induced roll torques will be measured and will help inform the RoCS for the final Ares I design. The Roll Control System is an integral, modular, bi-prop propulsion system housed in the USS Interstage segment (Figure 12). The RoCS uses off-the-shelf and GFE components—including nitrogen tetroxide and monomethyl hydrazine propellant tanks, helium pressurization tanks, and engine nozzles—that have been harvested from Peacekeeper Stage IV, then re-integrated into a system. The Ares I-X FTV will have two engine sets mounted on the interstage (IS-1) segment.

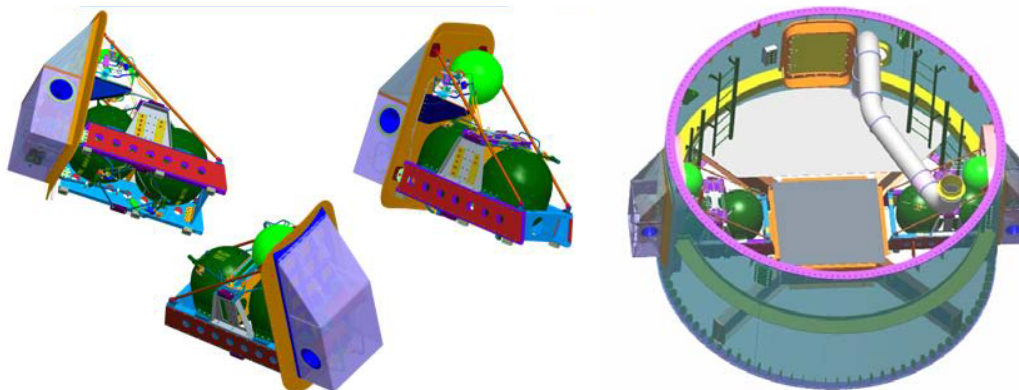

Figure 12. The images at left depict the RoCS module from various orientations to reveal interior and exterior details, including the aerodynamic protuberance. The image at right shows the internal arrangement of the RoCS within the interstage segment.

Duty cycle testing for RoCS was conducted at the White Sands Test Facility in late 2007, and fuel tanking and detanking tests were performed at KSC in early 2008. This verification testing, performed at Hypergol Maintenance Facility (HMF), demonstrated loading pressurant and propellant (using de-ionized water) into Peacekeeper tanks/fill valve configuration, used HMF GSE planned for RoCS flight module loading, and verified and validated procedures and hardware well in advance of actual propellant loading in flight modules.

The RoCS team’s primary efforts are focused on completing hardware fabrication and integrating it into the modules, while working verification activities in parallel, leading to a Hardware Acceptance Review early September 2008. The RoCS team has high confidence that it will meet its delivery schedule for the 2009 launch.

E. Crew Module/Launch Abort System (CM/LAS) Simulator

Like the USS, the CM/LAS portion of Ares I-X will be simulator hardware (Figure 13). These forward sections differ slightly from the current iteration of the Ares I design because Ares I-X was baselined during an earlier design analysis cycle (DAC). However, the CM/LAS will still provide critical information about aerodynamic and acoustic loads on the Orion crew exploration vehicle. A total of 362 DFI sensors will be placed on and in the forward structures. The data from these sensors will be transmitted to the ground via telemetry. The sensors might also provide visibility into the thrust oscillation issue Ares I is studying. The CM/LAS CDR was completed in mid-March 2008. Drawings for the hardware have been completed, and the hardware is in the process of being manufactured. NASA’s Langley Research Center (LaRC) is responsible for CM/LAS design and fabrication, installation and checkout of DFI, plus handling ground support equipment (GSE).

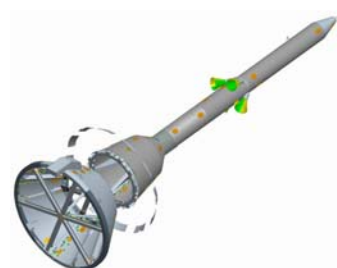

Figure 13. The Ares I-X CM/LAS simulator completed its CDR in February 2008.

The CM/LAS structure consists of several primary components, including the Orion crew module (CM) simulator, the LAS nozzles, the nosecone, and a transition structure between the mast and the CM known colloquially as a “party hat” (Figure 14).

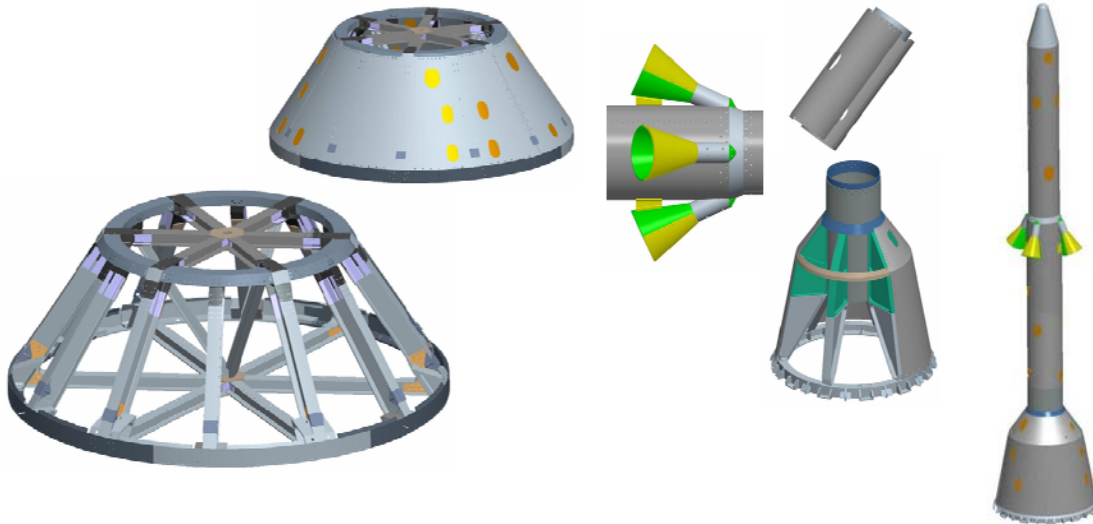

Figure 14. The CM/LAS components will match the shape and mass properties of the operational Orion CM and launch abort system.

The GO and CM/LAS teams are working together to ensure effective and efficient integration and operations in the Vehicle Assembly Building (VAB) when the CM/LAS arrives at KSC in November 2008. The LAS Tube segment (Figure 15) is currently being fabricated. Upon completion of the tube, assembly of CM/LAS “party hat” will commence.



Figure 15. The LAS tube section is in the midst of fabrication

F. Ground Systems/Ground Operations (GS/GO)

The Ares I-X flight will provide valuable experience for the KSC Ground Systems and Ground Operations teams in integrating, stacking, and launching Ares I. Most of the ground systems to be built for Ares I-X have undergone a 90 percent review and begun fabrication. Among the activities to be addressed will be transporting the vehicle elements to KSC, loading RoCS propellants in the Hypergol Maintenance Facility (HMF), processing the vehicle in the ARF and RPSF, stacking the vehicle in the VAB, and conducting vehicle rollout, and launch and recovery operations.

The USS segments and CM/LAS will be assembled into five stacks and the DFI will be tested in VAB High Bay 4. This will include integrating the first stage 5th spacer segment and forward structures into Stack 1. The FS segments and the stacks will be integrated in High Bay 3. The baseline schedule includes ten days for integrated testing. Closeouts—except for the Lower 5SS door (Ordnance Access)—are completed prior to rolling to the pad (Figure 16).



Figure 16. The VAB (left) will modify existing Shuttle handling hardware to stack Ares I-X.

GO is working to update the sequence of events and scheduling of ground asset usage which includes coordination with Shuttle operations. Some of the revised planning is a result of the Shuttle Hubble mission launch date change. The Hubble mission has affected when the MLP-1 will be available for turnover to Ares I-X.

IV. Summary and Conclusion

Data and operational lessons learned from Ares I-X will ensure the safety and reliability of America's newest launch vehicle. From the propulsion systems to the flight simulator hardware, avionics, and ground systems, the Ares I-X team has made great progress in the last two years, and had demonstrated that it is on track to meet its 2009 launch date.



National Aeronautics and Space Administration

Ares I-X Flight Test— The Future Begins Here

Stephan R. Davis
July 2008

www.nasa.gov





- ◆ **Deliver crew and cargo for missions to International Space Station (ISS) and to Moon and beyond**
- ◆ **Continuing progress toward design, component testing, and early flight testing**
- ◆ **Ares I Crew Launch Vehicle**
 - Will carry 6 crew to ISS, 4 to Moon
 - First flight test 2009
 - Initial Operating Capability 2015
- ◆ **Ares V Cargo Launch Vehicle**
 - Will launch Earth departure stage and Altair lunar lander to low Earth orbit for lunar missions
 - Largest launch vehicle ever designed
 - Will begin detailed development work in 2011



- ◆ **Ares I-X is a development test flight to provide engineering data to inform the design of the Ares I prior to CDR.**

Ares I will replace the Space Shuttle which is scheduled for 2010 retirement

- ◆ **Ares I-X is an uncrewed, sub-orbital development flight test.**
- ◆ **Ares I-X will provide opportunity to test ground facilities and operations at NASA's Kennedy Space Center.**



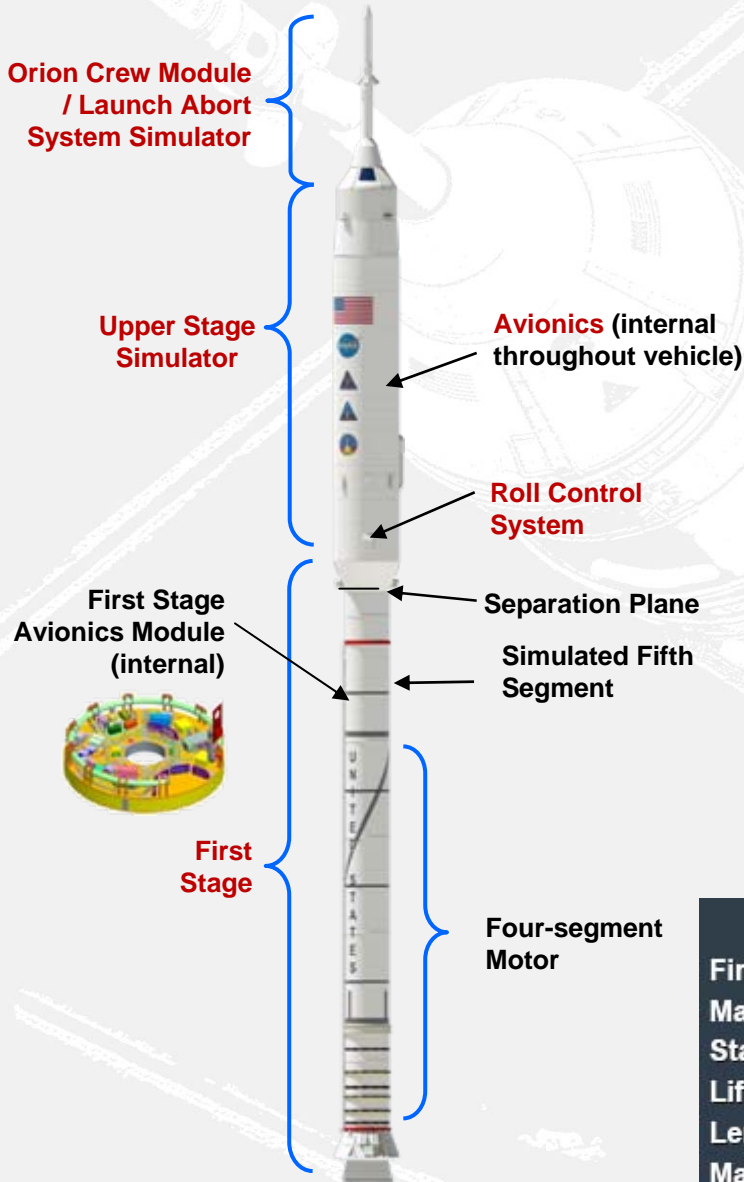

◆ **Combines proven space flight and simulated hardware**

• **Space flight hardware includes:**

- Four-segment solid rocket booster (Space Shuttle)
- Atlas V-based avionics
- Roll control system (Peacekeeper)
- Separation system (Space Shuttle)
- Parachutes deceleration system (Space Shuttle)
- Booster deceleration and tumble motors (Space Shuttle)
- Developmental flight instrumentation

• **Simulator hardware**

- Upper stage
- Orion crew module
- Launch abort system
- Fifth segment of booster

	Ares I-X	Ares I
First Stage Max. Thrust (vacuum):	14.1M N (3.13M lbf)	15.8M N (3.5M lbf)
Max. Speed:	Mach 4.7	Mach 5.84
Staging Altitude:	39,624 m (130,000 ft)	57,453 m (188,493 ft)
Liftoff Weight:	834k kg (1.8M lbm)	927k kg (2.0M lbm)
Length:	99.1 m (327 ft)	99 m (325 ft)
Max. Acceleration:	2.46 g	3.79 g



- P(1) Demonstrate control** of a dynamically similar, integrated Ares I/Orion, using Ares I relevant ascent control algorithms.
- P(2) Perform an in-flight separation/staging** event between a Ares I-similar First Stage and a representative Upper Stage.
- P(3) Demonstrate assembly and recovery** of a new Ares I-like First Stage element at KSC.
- P(4) Demonstrate First Stage separation sequencing, and quantify First Stage atmospheric entry dynamics, and parachute performance.**
- P(5) Characterize magnitude of integrated vehicle roll torque** throughout First Stage flight.

Ares I-X Development Flight Test

P2) Perform in-flight separation/staging event at 124 sec ~ 130,000 feet

~ 150,000 feet

Vehicle Height:	327 feet
Weight at Ignition:	1.8 M-lbm
Max. Acceleration:	2.5 g's
Max. Speed:	Mach 4.7

P4) Demonstrate FS entry dynamics and sequencing of events (parachute deployment, etc.)

P5) Characterize integrated vehicle roll torque

in-flight separation plane

P1) Demonstrate controlability

P3) Demonstrate assembly and recovery of an Ares I similar FS

**USS/CM/LAS
Uncontrolled descent and impact**

Booster, parachutes and recovery



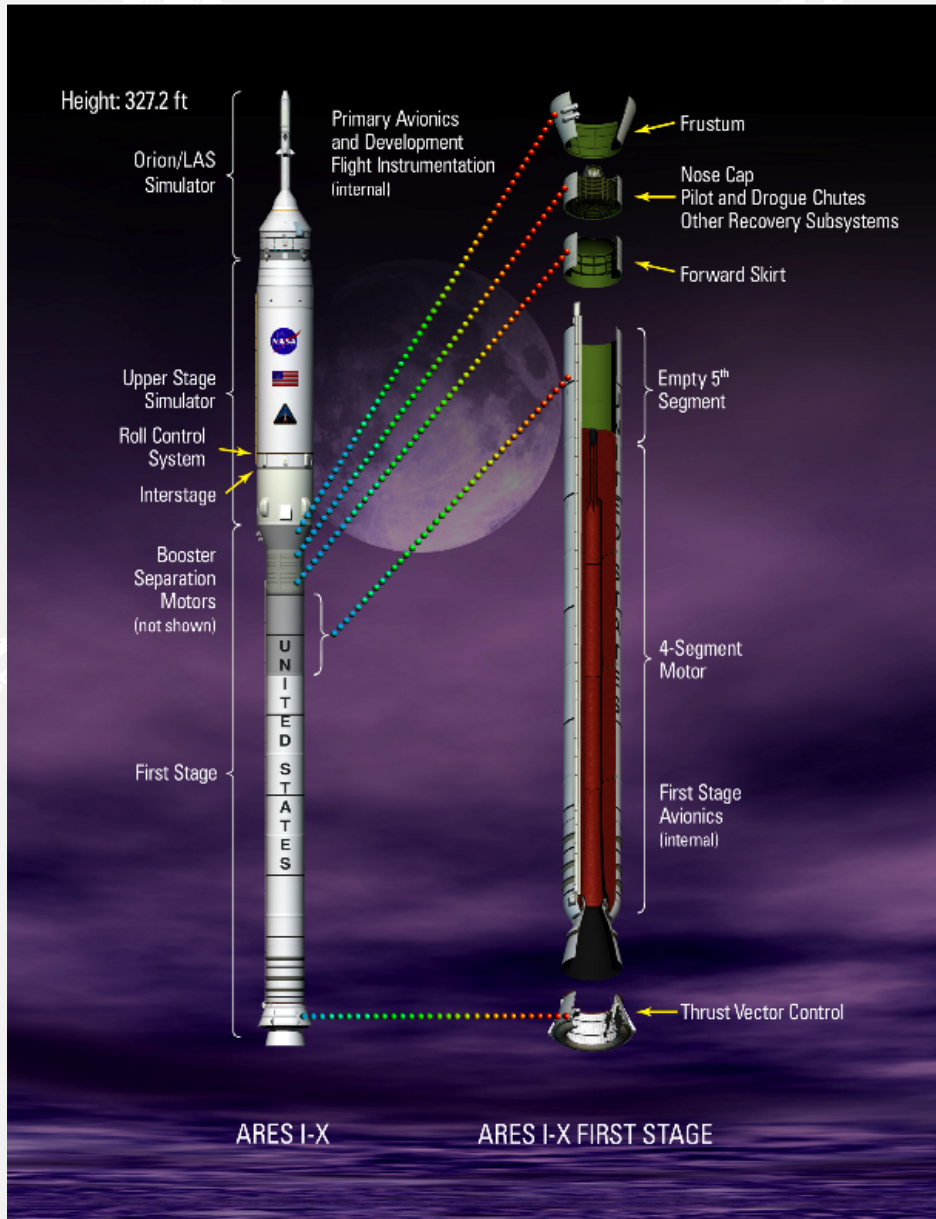

◆ Heritage Hardware

- 4 Segment Reusable Solid Rocket Motor (RSRM) w/Nozzle
- Thrust Vector Control (TVC)
- Flight Termination System (FTS)
- Nose Cap w/Thrusters
- Booster Separation Motors (BSMs)

◆ Modified Heritage Hardware

- Shuttle Derived Avionics
- Aft Skirt

◆ New Developments for Ares I-X

- Fifth Segment Simulator (5SS)
- Forward Skirt (FS)
- Forward Skirt Extension (FSE)
- Main Parachute Support Structure (MPSS)
- Frustum

◆ Ares I Designs

- Parachutes
- FTS Extension to Aft Segment

◆ Managed at the NASA Marshall Space Flight Center, Huntsville, AL



Redundant Rate Gyro (RRGU)

Fault Tolerant Inertial Navigation Unit (FTINU)

Redundant Rate Gyro (RRGU)



First Stage Avionics Module (FSAM) (Lockheed Martin Space Systems (LMSS))

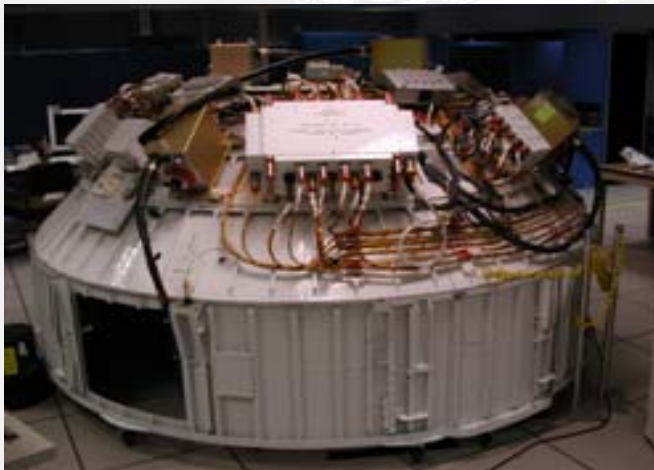

Atlas V System Integration Lab (SIL) (LMSS)

- ◆ **Primary avionics subsystems:**
 - **FSAM (located in First Stage fifth segment)**
 - **Guidance & Control System**
 - **Ground Command, Control, and Communication (GC3)**

- ◆ **Managed at the NASA Marshall Space Flight Center, Huntsville, AL**

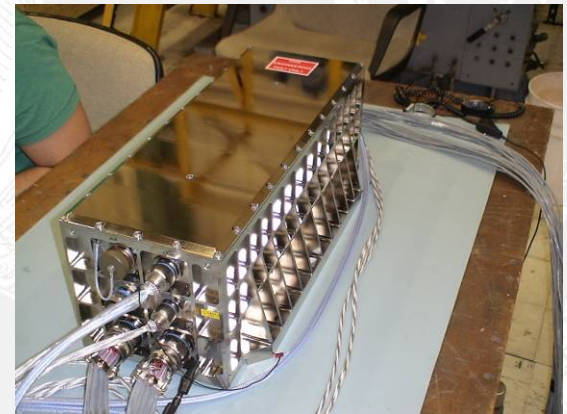

Ascent Thrust Vector Controller (ATVC) (Honeywell International)



Avionics Progress



Component(s)	Current Status (As Appropriate)	Anticipated Completion/Delivery
ATVC	CDR completed June 2007 Fabrication under way	Oct-08
FSAM	CDR completed April 2008	Oct-08
Flight Software	CDR completed March 2008 Test Readiness Review completed April 2008	Mar-09
Ground Software (Ground Control, Command, and Communications/GC3)	Formal testing under way	Delivery to KSC October 2008 Installation in MLP by May 2009
Systems Integration Laboratory Vehicle Flight Control Testing Flight Simulation Testing	Ongoing Ongoing	Oct-08 May-09
OFI / DFI Sensors and Harnesses	Sensors acquired or on order Undergoing Table Top Reviews as completed	<i>Cable Harnesses</i> CM/LAS July 2008 USS October 2008 FS October 2008 <i>OFI Harnesses</i> FS/USS October 2008
Fault Tolerant Inertial Navigation Unit (FTINU)	Qualification testing complete Delivered to United Launch Alliance in March 2008	Delivery to KSC March 2009
SDA	Fabrication begun December 2007	Aug-08

Upper Stage Simulator (USS)

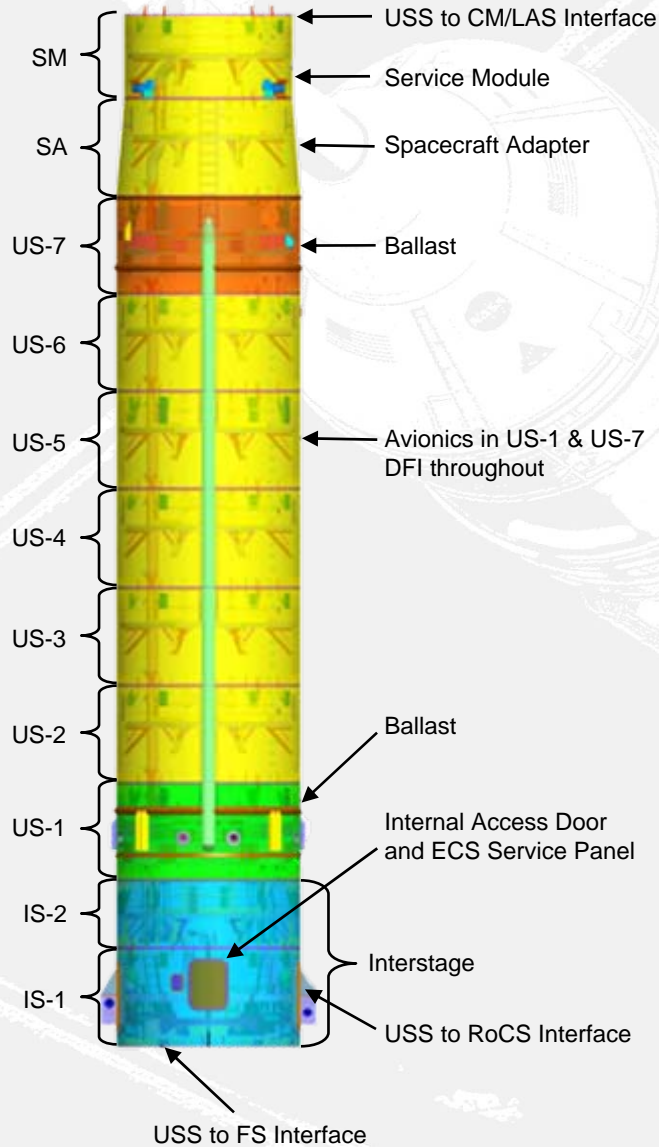

◆ **USS is a mass and Outer Mold Limit (OML) simulator**

◆ **Hardware includes:**

- Interstage (IS) Simulator
- Upper Stage (US) Simulator
- Spacecraft Adapter (SA) Simulator
- Service Module (SM) Simulator

◆ **Developed at the NASA Glenn Research Center, Cleveland, OH**



USS Internal Access Concept

- ◆ Provides access from the Frustum to the CM/LAS.
- ◆ Door in the IS-1 segment
 - Internal access platforms and ladders
 - Provides Environmental Control System (ECS) ductwork to maintain a safe work temp, air flow and controlled humidity

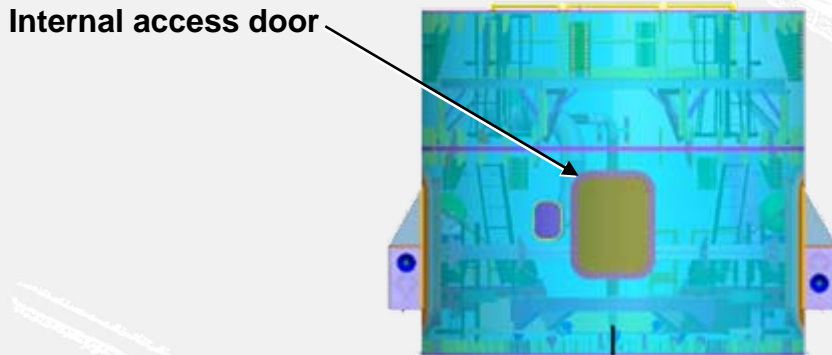

IS-1 Segment

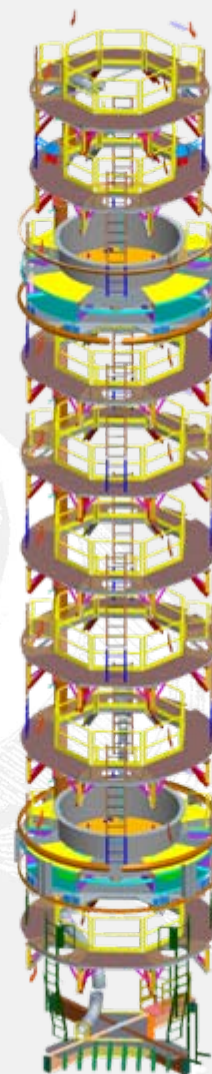

Common access platforms with railings

Ballast platform

FS Frustum

Roll Control System (RoCS)

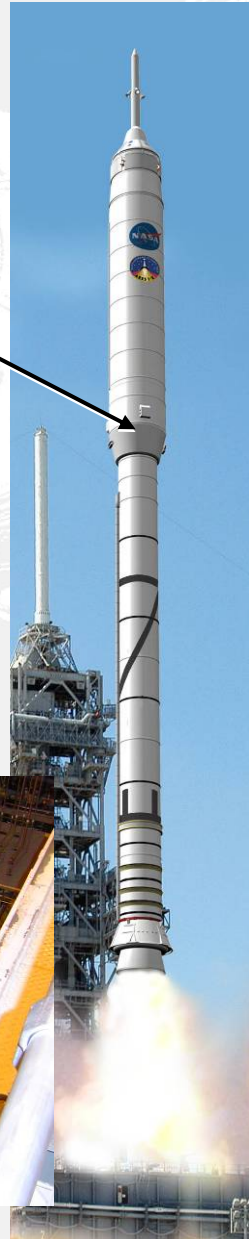
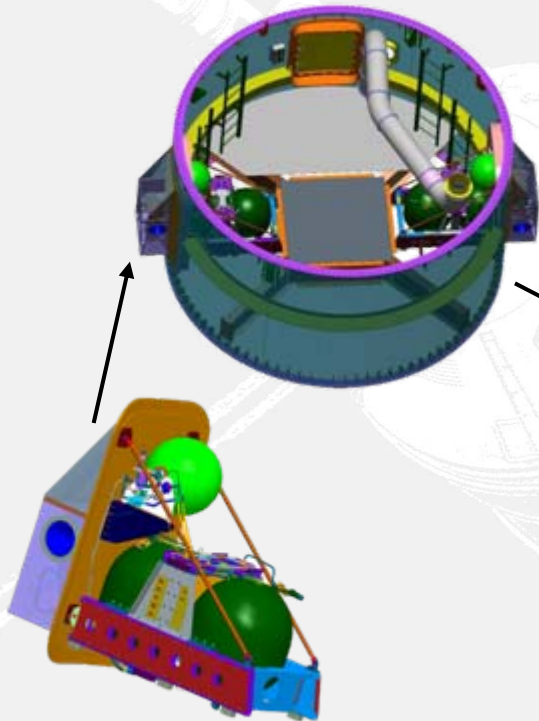

- ◆ Provides post-launch 90-degree roll and mitigation against adverse roll torques
- ◆ Modular propulsion system housed in the Ares I-X USS Interstage
- ◆ Proven space hardware harvested from Peacekeeper 4th Stage
- ◆ Managed at the NASA Marshall Space Flight Center, Huntsville, AL



◆ **Instrumented for 924 measurements.**

- Thermal
- Structures
- GNC/Trajectory
- Aero
- Shock

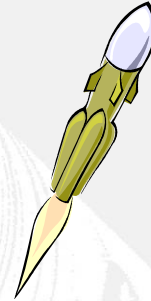

◆ **Cameras strategically located.**

◆ **Data to be retrieved via telemetry and a data recorder box that is recovered from the First Stage after flight.**

◆ **Managed at the NASA Langley Research Center, Hampton, VA**

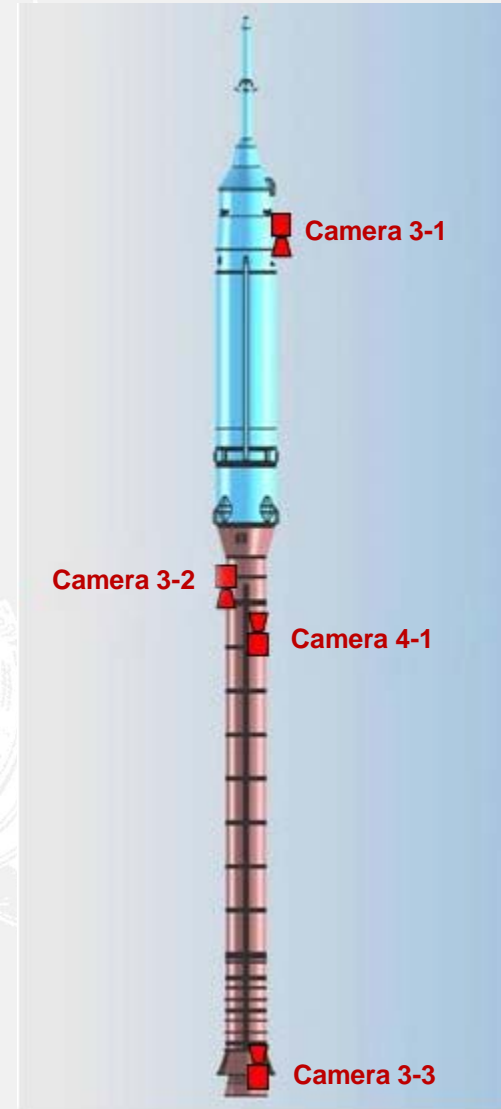

Orion Crew Module/ Launch Abort System (CM/LAS) Simulator

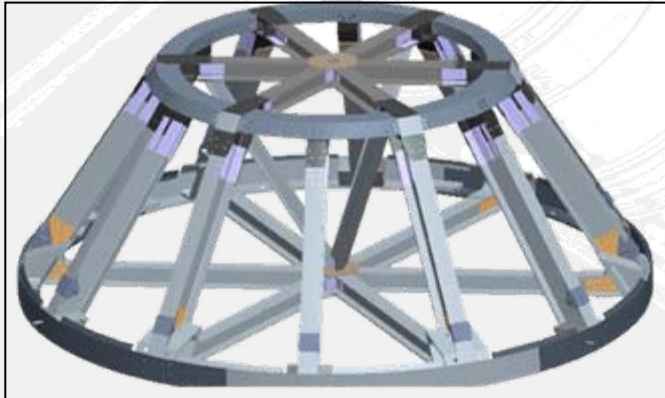
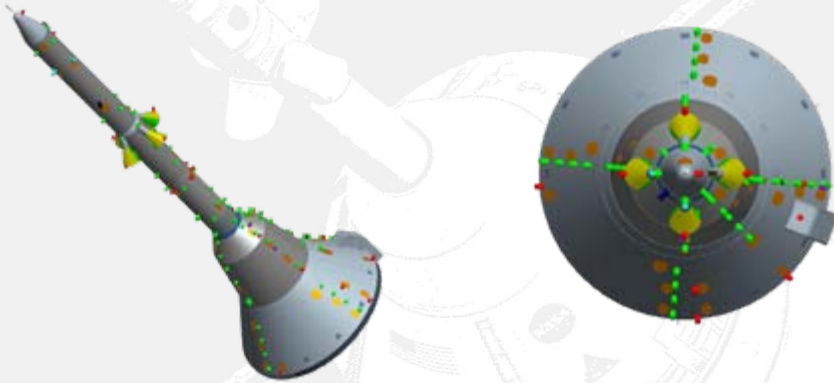

- ◆ **Outer mold limit (OML) resembles earlier Ares I design due to flight test schedule**
- ◆ **Developmental flight instrumentation sensors will measure aerodynamic and acoustic loads**
- ◆ **Developed at the NASA Langley Research Center, Hampton, VA**

Vehicle Assembly Building (VAB) Operations

- ◆ The Upper Stage Simulator (USS) segments and Orion Crew Module/Launch Abort System (CM/LAS) will be assembled into stacks and Development Flight Instrumentation (DFI) tested in VAB Hi-Bay 4.
- ◆ The First Stage segments and stacks will be integrated in Hi-Bay 3.



Hi-Bay 3 Stacks in VAB

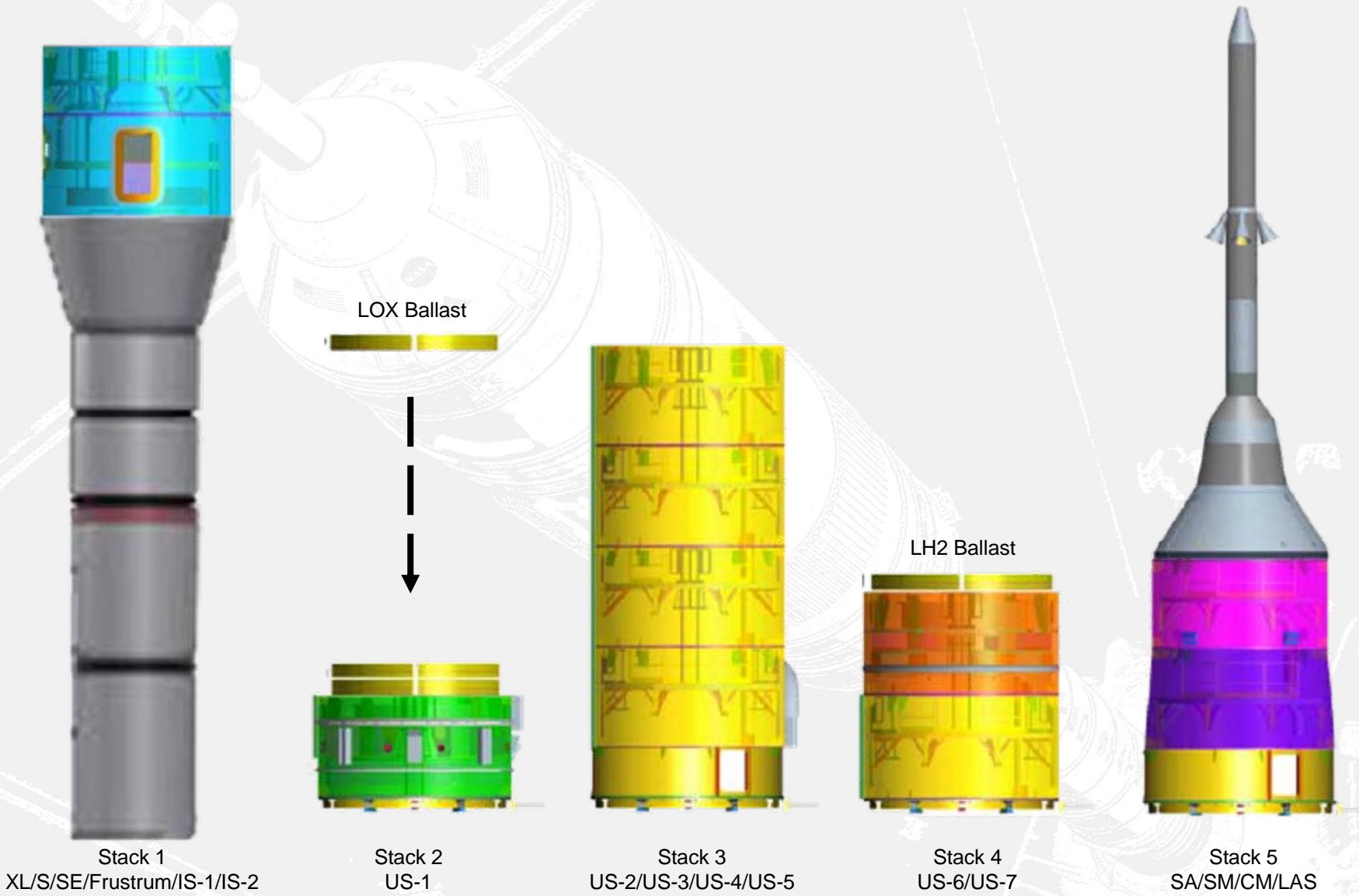

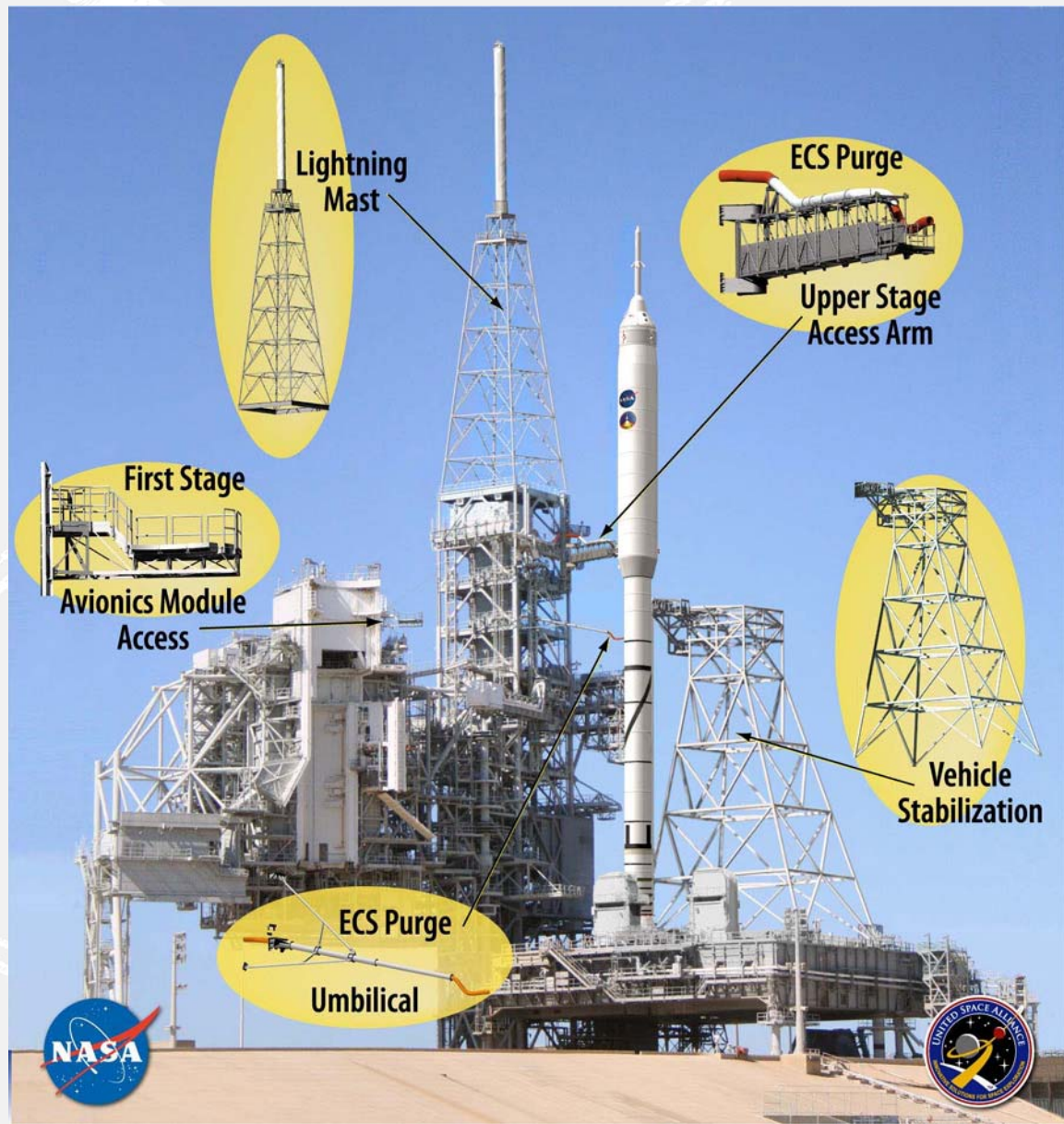

- ◆ Lightning Mast raised 100ft
- ◆ Vehicle stabilization concept shown



- ◆ **Ares I-X is the first flight of NASA's new Constellation Program.**
- ◆ **Ares I-X is a developmental test flight to support the Ares I.**
- ◆ **Ares I-X is on track for May 2009 launch date.**
- ◆ **For more information, see <http://www.nasa.gov>**

