

NASA/TM—2008-215430



# Shear Modulus for Nonisotropic, Open-Celled Foams Using a General Elongated Kelvin Foam Model

*Roy M. Sullivan*  
*Glenn Research Center, Cleveland, Ohio*

*Louis J. Ghosn*  
*Ohio Aerospace Institute, Brook Park, Ohio*

## NASA STI Program . . . in Profile

Since its founding, NASA has been dedicated to the advancement of aeronautics and space science. The NASA Scientific and Technical Information (STI) program plays a key part in helping NASA maintain this important role.

The NASA STI Program operates under the auspices of the Agency Chief Information Officer. It collects, organizes, provides for archiving, and disseminates NASA's STI. The NASA STI program provides access to the NASA Aeronautics and Space Database and its public interface, the NASA Technical Reports Server, thus providing one of the largest collections of aeronautical and space science STI in the world. Results are published in both non-NASA channels and by NASA in the NASA STI Report Series, which includes the following report types:

- **TECHNICAL PUBLICATION.** Reports of completed research or a major significant phase of research that present the results of NASA programs and include extensive data or theoretical analysis. Includes compilations of significant scientific and technical data and information deemed to be of continuing reference value. NASA counterpart of peer-reviewed formal professional papers but has less stringent limitations on manuscript length and extent of graphic presentations.
- **TECHNICAL MEMORANDUM.** Scientific and technical findings that are preliminary or of specialized interest, e.g., quick release reports, working papers, and bibliographies that contain minimal annotation. Does not contain extensive analysis.
- **CONTRACTOR REPORT.** Scientific and technical findings by NASA-sponsored contractors and grantees.
- **CONFERENCE PUBLICATION.** Collected

papers from scientific and technical conferences, symposia, seminars, or other meetings sponsored or cosponsored by NASA.

- **SPECIAL PUBLICATION.** Scientific, technical, or historical information from NASA programs, projects, and missions, often concerned with subjects having substantial public interest.
- **TECHNICAL TRANSLATION.** English-language translations of foreign scientific and technical material pertinent to NASA's mission.

Specialized services also include creating custom thesauri, building customized databases, organizing and publishing research results.

For more information about the NASA STI program, see the following:

- Access the NASA STI program home page at <http://www.sti.nasa.gov>
- E-mail your question via the Internet to [help@sti.nasa.gov](mailto:help@sti.nasa.gov)
- Fax your question to the NASA STI Help Desk at 301-621-0134
- Telephone the NASA STI Help Desk at 301-621-0390
- Write to:  
NASA Center for AeroSpace Information (CASI)  
7115 Standard Drive  
Hanover, MD 21076-1320



# Shear Modulus for Nonisotropic, Open-Celled Foams Using a General Elongated Kelvin Foam Model

*Roy M. Sullivan*  
*Glenn Research Center, Cleveland, Ohio*

*Louis J. Ghosn*  
*Ohio Aerospace Institute, Brook Park, Ohio*

National Aeronautics and  
Space Administration

Glenn Research Center  
Cleveland, Ohio 44135

*Level of Review:* This material has been technically reviewed by technical management.

Available from

NASA Center for Aerospace Information  
7115 Standard Drive  
Hanover, MD 21076-1320

National Technical Information Service  
5285 Port Royal Road  
Springfield, VA 22161

Available electronically at <http://gltrs.grc.nasa.gov>

# Shear Modulus for Nonisotropic, Open-Celled Foams Using a General Elongated Kelvin Foam Model

Roy M. Sullivan  
National Aeronautics and Space Administration  
Glenn Research Center  
Cleveland, Ohio 44135

Louis J. Ghosn  
Ohio Aerospace Institute  
Brook Park, Ohio 44142

## Summary

An equation for the shear modulus for nonisotropic, open-celled foams in the plane transverse to the elongation (rise) direction is derived using an elongated Kelvin foam model with the most general geometric description. The shear modulus was found to be a function of the unit cell dimensions, the solid material properties, and the cell edge cross-section properties. The shear modulus equation reduces to the relation derived by others for isotropic foams when the unit cell is equiaxed.

## Introduction

Over the years, there have been numerous attempts to develop equations that are capable of predicting the strength and the elastic properties of open- and closed-cell foams from a description of the foam microstructure and a measure of the cell dimensions. This endeavor requires selecting a suitable representative element to mimic the foam microstructure. Many of these micromechanics models have used a tetrakaidecahedron (a 14-sided polyhedron) to represent the foam microstructure. This choice follows from the work of Thomson (1887) who argued that the 14-sided polyhedron (with slightly curved faces) was the naturally preferred shape for soap bubbles and other foams as it is the shape that minimizes the surface area per unit volume and still packs to fill space. As a result, the tetrakaidecahedron model is widely known as the Kelvin foam model.

Some of the more notable studies in this area are the works of Zhu, Knott, and Mills (1997), Warren and Kraynik (1997), Dement'ev and Tarakanov (1970), and Gong, Kyriakides, and Jang (2005). Zhu used an equiaxed tetrakaidecahedron and assumed that the behavior of open-celled foams could be simulated by treating the cell edges as structural elements possessing axial, bending, and torsional rigidity. They applied the minimum potential energy theorem to the unit cell deformation and developed equations for the Young's modulus, the shear modulus, and Poisson's ratio for isotropic, open-celled foams. These equations were derived in terms of the cell edge lengths, the edge cross-section properties, and the solid material properties.

In some cases, the foam cells are elongated; as a result, these foams exhibit a nonisotropic mechanical behavior. Such is the case in spray-on foams where the cells become elongated in the rise direction during the foaming and rising process. To treat nonisotropic, open-celled foams, Dement'ev and Tarakanov (1970) used an elongated Kelvin model to derive equations for the elastic constants and compressive strengths in the principal material directions. The equations for the elastic constants were derived by considering the flexural deformation of the cell edges under the applied stresses. The compressive strength equations were obtained based on the critical (Euler) buckling load of the edges.

Gong, Kyriakides, and Jang (2005) also adopted an elongated Kelvin unit cell to model nonisotropic foams. They improved upon the fidelity of the previous models by using Plateau borders to represent the edge cross sections and by allowing the dimensions of the cross section to vary along the edge length. They also included the effects of shear deformation.

The size and shape of the elongated Kelvin unit cell used by Dement'ev and Tarakanov (1970), Gong, Kyriakides, and Jang (2005), and others are defined by specifying two unit cell dimensions: either the cell height and cell width or the height-to-width ratio and one of the two cell dimensions. In the most general sense, however, an elongated tetrakaidecahedron has three independent dimensions. Sullivan, Ghosn, and Lerch (2008) recognized this shortcoming with the previous models and proposed using an elongated Kelvin model with three independent dimensions to model nonisotropic, open-celled foams. Following the same approach as Zhu, Knott, and Mills (1997), Sullivan, Ghosn, and Lerch (2008) applied the principle of minimum potential energy to the unit cell deformation and derived the equations for the Young's modulus, Poisson's ratios, and tensile strengths in the principal material directions, thereby establishing a foam micromechanics model using the most general Kelvin unit cell.

This report is intended as a supplement to Sullivan, Ghosn, and Lerch (2008) as it uses the general Kelvin unit cell model and a similar potential energy approach to develop the equation for the shear modulus in the plane perpendicular to the elongated (rise) direction. Herein, the general Kelvin foam model is reviewed. Since the elongated Kelvin unit cell is symmetric, one-quarter of the Kelvin cell is chosen as the repeating unit cell. Displacement conditions are applied to the unit cell boundaries to ensure that the unit cell remains a representative repeating unit during shear deformation. The principle of minimum potential energy is applied to the unit cell deformation, yielding an algebraic equation for the shear strain in terms of the shear stress. From this, the equation for the shear modulus is derived.

## Elongated Kelvin Unit Cell

The general elongated tetrakaidecahedron (Kelvin foam model) is a 14-sided polyhedron constructed from 8 hexagonal faces, 4 vertical rhombic faces, and 2 horizontal square faces (fig. 1). The vertical rhombic faces have sides of length  $L$ , and the horizontal square faces have sides of length  $b$ . The hexagonal faces have four sides of length  $L$  and two sides of length  $b$ . The inclination angle  $\theta$  defines the orientation of the hexagonal faces with respect to the rise direction as well as the obtuse angle of the vertical diamond faces  $2\theta$ . The edges are the line segments formed by the intersection of multiple faces. Thus, the edges will be of length  $L$  or  $b$ .

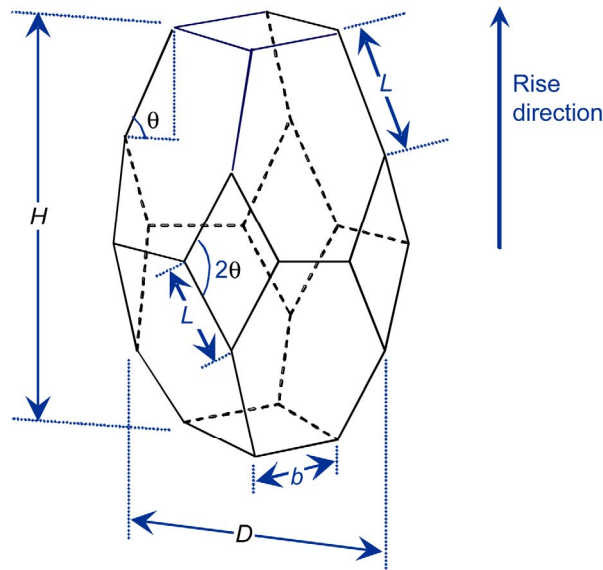

Figure 1.—Elongated tetrakaidecahedron repeating unit cell (Kelvin model).

Since the cell height  $H$  and cell width  $D$  are related to the edge lengths  $L$  and  $b$  and the inclination angle  $\theta$  according to

$$H = 4L \sin \theta \quad \text{and} \quad D = 2L \cos \theta + \sqrt{2} b \quad (1)$$

the size and shape of the general elongated tetrakaidehedron are defined by specifying three of the five unit cell dimensions shown in figure 1.

In open-celled foams, all the solid mass is concentrated within the cell edges. The edges are assumed to behave like structural members, possessing axial, flexural, and torsional rigidity. They have cross-sectional area  $A$ , bending moment of inertia  $I$ , and torsion constant  $J$ . The Young's modulus of the solid material is denoted as  $E$  and the shear modulus as  $G$ .

### Unit Cell Deformation

We first establish a Cartesian coordinate system  $XYZ$  such that the  $Z$ -axis is oriented in the elongation or rise direction (fig. 2). The  $X$ -axis is parallel to a line normal to two of the vertical rhombic faces, and the  $Y$ -axis is parallel to a line normal to the other two vertical rhombic faces. We seek to derive the equation for the foam shear modulus  $G_{xy}$ . For this purpose, we adopt the structural unit shown in red in figure 2 as the representative repeating unit. This repeating unit is a one-quarter segment of the Kelvin foam unit cell shown in figure 1.

Next, we establish the  $X_s Y_s Z$ -coordinate system that is oriented with respect to the  $XYZ$ -system by a  $45^\circ$  counterclockwise rotation about the  $Z$ -axis. The repeating structural unit is bounded by six symmetry planes: two planes parallel to the  $Y_s Z$ -plane, two planes parallel to the  $X_s Z$ -plane, and two planes parallel to the  $X_s Y_s$ -plane. Since the members  $AN$ ,  $AO$ ,  $BJ$ ,  $BK$ ,  $DM$ ,  $DL$ ,  $EP$ , and  $EQ$  all lie within the  $X_s Y_s$ -symmetry planes, they are shared by two adjacent unit cells. As such, we assume that within the unit cell, they possess a cross-sectional area  $A/2$  and a bending moment of inertia  $I/2$ . The repeating structural unit and symmetry planes constitute the repeating unit cell for determining the shear modulus  $G_{xy}$ .

The normal stresses  $\tau$  and  $-\tau$  are applied in the  $X_s$ - and  $Y_s$ -directions, respectively, as shown in figure 3. We define the displacements of the unit cell with respect to the unit cell center at point  $C$  and assume that all displacements and rotations at point  $C$  are zero. The applied loading results in a unit cell displacement of  $2u$  in the  $X_s$ -direction and  $-2u$  in the  $Y_s$ -direction, where both displacements are symmetric about point  $C$ . There is no displacement of the unit cell in the  $Z$ -direction (fig. 4).

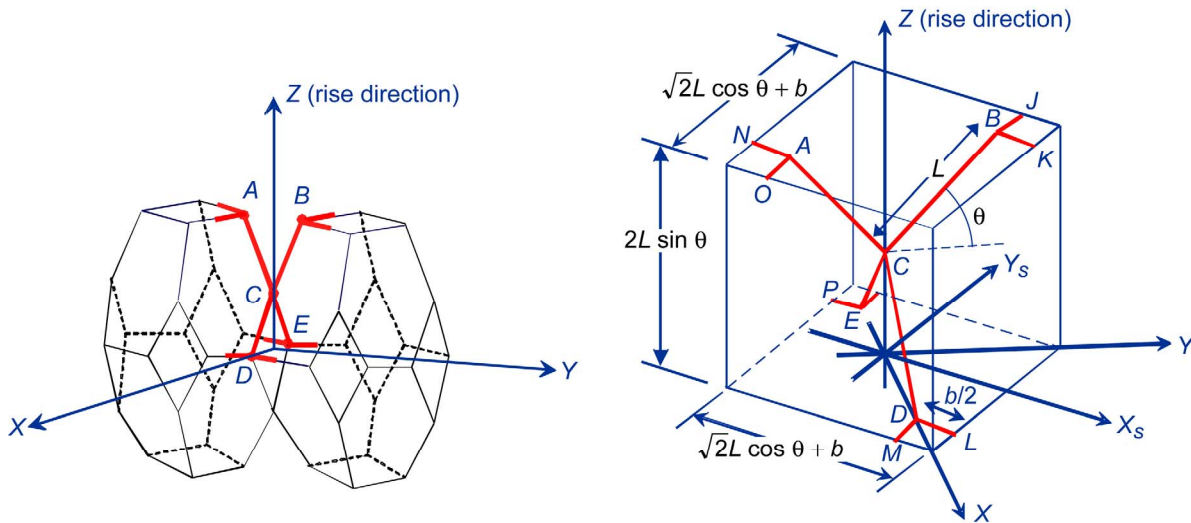

Figure 2.—One-quarter model showing its reference with respect to elongated Kelvin unit cell (point  $Q$  not shown; see figs. 3 and 4).

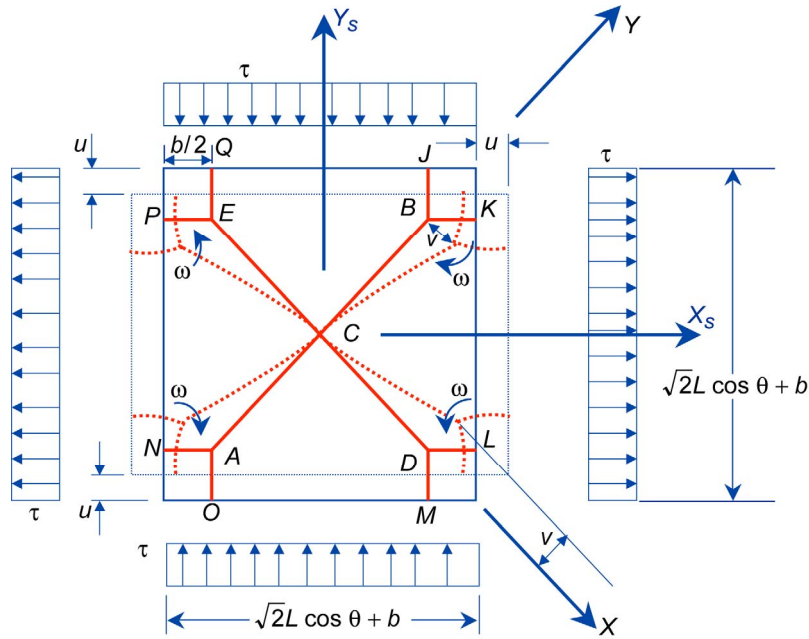

Figure 3.—Applied loading and deformed shape of unit cell (XY-plane).

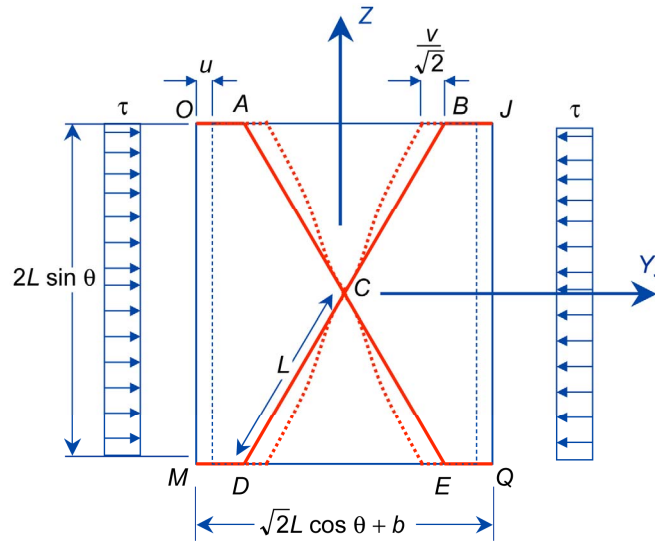

Figure 4.—Applied loading and deformed shape of unit cell ( $Y_sZ$ -plane).

In the deformed structure, we assume that the symmetry planes remain orthogonal. Any edge that is initially normal to a symmetry plane boundary will remain normal to it after the deformation. Thus, the points  $J, K, L, M, N, O, P,$  and  $Q$  do not rotate during the deformation. Furthermore, the half-edges  $AN, AO, BJ, BK, DL, DM, EQ,$  and  $EP$  must remain in their respective symmetry planes. Thus, the points  $A, B, D,$  and  $E$  translate within their respective symmetry planes and the only rotation of these points is about the  $Z$ -axis. Point  $B$  translates in the  $X$ -direction by an amount  $v$  and point  $A$  translates by an amount  $-v$ . Points  $D$  and  $E$  translate in the  $Y$ -direction an amount  $v$  and  $-v$ , respectively. Points  $A$  and  $B$  undergo a clockwise rotation  $\omega$  about the  $Z$ -axis, and points  $D$  and  $E$  undergo a counterclockwise rotation  $\omega$ .

We note that as a result of similarity and symmetry, the deformed shape and the deformation energy of member  $BC$  are the same as those of members  $CD, AC,$  and  $CE$ . Likewise, the deformed shape and



deformation energy of the members  $BK$ ,  $DL$ ,  $AN$ , and  $EP$  are equivalent and those of members  $BJ$ ,  $DM$ ,  $AO$ , and  $EQ$  are equivalent. Furthermore, the axial tension in member  $BK$  is equal to the axial compression in member  $BJ$ , and the bending moment in  $BJ$  is equal to the bending moment in  $BK$ . Thus, the deformation energy of the entire unit cell can be determined from the strain energy of deformation of only members  $BC$  and  $BK$ .

### Strain Energy of Member $BC$

We will make use of a third coordinate system  $X'Y'Z'$ , where the  $Y'$ -axis is oriented along the length of member  $BC$  as shown in figure 5. Since there is no normal stress applied to the unit cell in the  $Y$ - or  $Z$ -direction (see fig. 3), the axial force  $N_{BC}$ , the shear force  $V_{z'}$ , as well as the bending moment about the  $X'$ -axis  $M_{x'}$ , must be zero throughout the length of the member. Furthermore, there is no deformation of member  $BC$  in the  $YZ$ - (or  $Y'Z'$ -) plane. The only deformation energy in member  $BC$  is that associated with bending about the  $Z'$ -axis  $M_{z'}^{BC}$  and the torsional deformation associated with  $M_{y'}^{BC}$ . The displacements and rotations at point  $B$  in the  $X'Y'Z'$ -coordinate system are summarized as

$$\begin{Bmatrix} u_{x'}^B \\ u_{y'}^B \\ u_{z'}^B \end{Bmatrix} = \begin{Bmatrix} v \\ 0 \\ 0 \end{Bmatrix} \quad \text{and} \quad \begin{Bmatrix} \theta_{x'}^B \\ \theta_{y'}^B \\ \theta_{z'}^B \end{Bmatrix} = \begin{Bmatrix} 0 \\ \omega \sin \theta \\ \omega \cos \theta \end{Bmatrix}$$

The member end forces and moments at point  $B$  are shown in figure 5(a), and the active degrees of freedom at  $B$  are shown in figure 5(b).

Considering the deformation of member  $BC$  in the  $X'Y'$ -plane, the member end displacement and rotation at point  $B$  are related to the member end force and moment (fig. 6), using the first and second moment-area theorems as

$$\frac{M_{z'}^{BC} L}{EI} + \frac{V_x^B L^2}{2EI} = \omega \cos \theta \quad (2)$$

and

$$\frac{M_{z'}^{BC} L^2}{2EI} + \frac{V_x^B L^3}{3EI} = v \quad (3)$$

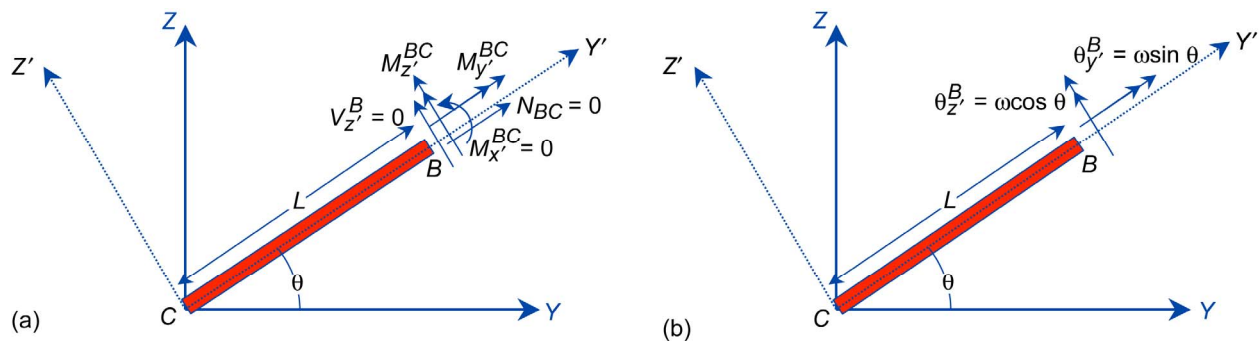

Figure 5.—Member  $BC$  showing member end forces and moments and member end displacements and rotations at point  $B$  in  $YZ$ -plane. (a) End forces and end moments. (b) End displacements and rotations.

respectively. Solving equations (2) and (3) simultaneously, we obtain

$$V_x^B = \frac{12EI}{L^3} \left( v - \frac{\omega L}{2} \cos \theta \right) \quad (4)$$

$$M_{z'}^{BC} = \frac{2EI}{L} \left( 2\omega \cos \theta - 3\frac{v}{L} \right) \quad (5)$$

Considering the torsional deformation of member  $BC$  yields

$$M_{y'}^{BC} = \frac{GJ}{L} \omega \sin \theta \quad (6)$$

The strain energy for member  $BC$  is

$$U_{BC} = \frac{(M_{y'}^{BC})^2 L}{2GJ} + \frac{1}{2EI} \int_0^L (M_{z'}^{BC} + V_x^B s)^2 ds$$

where  $s$  is the local coordinate oriented along member  $BC$ , having the value  $s = 0$  at point  $B$  and  $s = L$  at point  $C$ . Using equations (4), (5), and (6), the strain energy may be written in terms of the displacements  $v$  and  $\omega$  as

$$U_{BC} = \frac{GJ}{2L} \omega^2 \sin^2 \theta + \frac{EI}{L^3} (2L^2 \omega^2 \cos^2 \theta + 6v^2 - 6vL\omega \cos \theta) \quad (7)$$

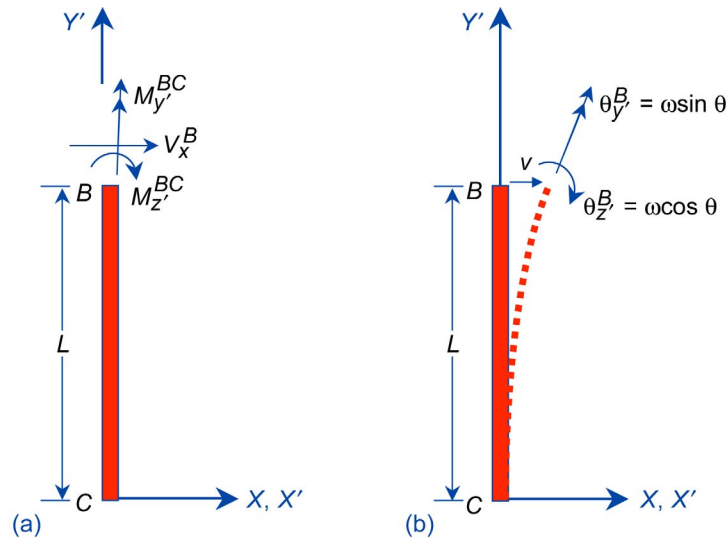

Figure 6.—Member  $BC$  showing member end forces and moments and member end displacements and rotations in  $X'Y'$ -plane. (a) End forces and moments. (b) End displacements and rotations.

## Strain Energy of Member *BK*

Member *BK* remains in the symmetry plane defined by the points *A*, *B*, and *K*. The only deformation energy in member *BK* is that associated with the axial extension and bending about the *Z*-axis. There is no *Y<sub>s</sub>*-direction loading on member *BK* at point *K*. Thus, there is no transverse (shear) force in the member, and the bending moment about the *Z*-axis is constant along the member length. Transforming the displacements at point *B* into the *X<sub>s</sub>Y<sub>s</sub>Z*-coordinate system, we have  $u_{x_s}^B = v/\sqrt{2}$ ,  $u_{y_s}^B = -v/\sqrt{2}$ ,  $u_z^B = 0$ . The member end forces and moments in member *BK* are shown in figure 7(a), and the member end point displacements and rotations are shown in figure 7(b).

The equation for the axial extension of member *BK* is

$$u - \frac{v}{\sqrt{2}} = \frac{N_{BK} \left( \frac{b}{2} \right)}{E \left( \frac{A}{2} \right)}$$

The end point rotations may be written in terms of the bending moment  $M_z$  by the first moment-area theorem as

$$\theta_z^B - \theta_z^K = \omega - 0 = \frac{M_z^{BK} \left( \frac{b}{2} \right)}{E \left( \frac{I}{2} \right)}$$

Rewriting the previous two equations, we obtain

$$N_{BK} = \frac{EA}{b} \left( u - \frac{v}{\sqrt{2}} \right) \tag{8}$$

$$M_z^{BK} = \frac{EI}{b} \omega \tag{9}$$

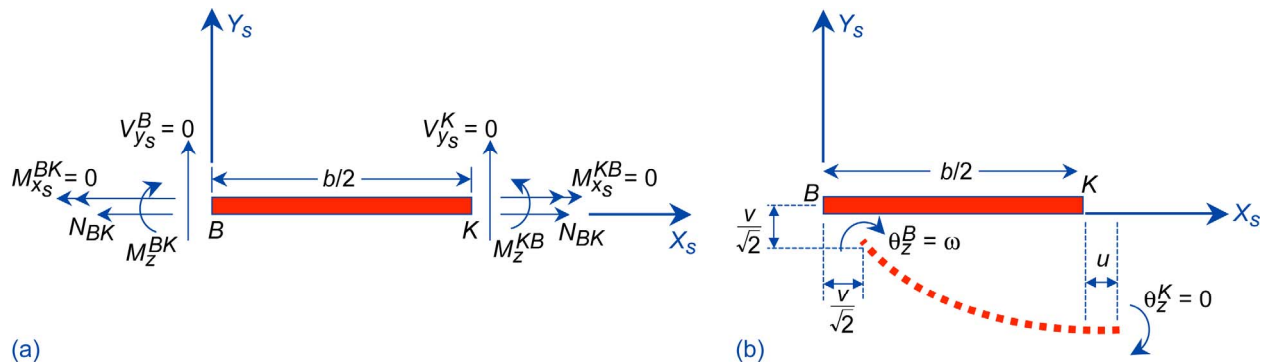

Figure 7.—Member *BK* showing member end forces and moments and member end displacements and rotations. (a) End forces and moments. (b) End displacements and rotations.

The strain energy for member BK is

$$U_{BK} = \frac{N_{BK}^2 \left(\frac{b}{2}\right)}{2\left(\frac{A}{2}\right)E} + \frac{1}{2E\left(\frac{I}{2}\right)} \int_0^{b/2} (M_z^{BK})^2 ds$$

which, by substituting equations (8) and (9), may be written in terms of the displacements  $u$ ,  $v$ , and  $\omega$  as

$$U_{BK} = \frac{EA}{2b} \left(u - \frac{v}{\sqrt{2}}\right)^2 + EI \frac{\omega^2}{2b} \quad (10)$$

### Derivation of Shear Modulus Equation

As a result of the symmetry and similarity of the unit cell deformation, the strain energy for the repeating unit cell shown in figure 2 is

$$U = 4U_{BC} + 8U_{BK} \quad (11)$$

The work done on the unit cell by the applied loading is

$$W = 8L \sin \theta (\sqrt{2}L \cos \theta + b) \tau u \quad (12)$$

Substituting equations (7) and (10) into (11) and applying the minimum potential energy theorem

$$\frac{\partial(W-U)}{\partial u} = 0 \quad \frac{\partial(W-U)}{\partial v} = 0 \quad \frac{\partial(W-U)}{\partial \omega} = 0$$

lead to

$$\frac{2EA}{b} u - \sqrt{2} \frac{EA}{b} v = 2L \sin \theta (\sqrt{2}L \cos \theta + b) \tau \quad (13a)$$

$$-\sqrt{2} \frac{EA}{b} u + \left(\frac{12EI}{L^3} + \frac{EA}{b}\right) v - \frac{6EI}{L^2} \cos \theta \omega = 0 \quad (13b)$$

$$-\frac{6EI}{L^2} \cos \theta v + \left(\frac{2EI}{b} + \frac{GJ}{L} \sin^2 \theta + \frac{4EI}{L} \cos^2 \theta\right) \omega = 0 \quad (13c)$$

Solving equations (13) simultaneously yields

$$u = \tau L \sin \theta (\sqrt{2}L \cos \theta + b) \left( \frac{b}{EA} + \frac{L^3 \left(2L + 4b \cos^2 \theta + \frac{GJ}{EI} b \sin^2 \theta\right)}{12EI \left(2L + b \cos^2 \theta + \frac{GJ}{EI} b \sin^2 \theta\right)} \right) \quad (14a)$$

$$v = \tau L^4 \sin \theta (\sqrt{2}L \cos \theta + b) \left( \frac{2L + 4b \cos^2 \theta + \frac{GJ}{EI} b \sin^2 \theta}{6\sqrt{2}EI \left( 2L + b \cos^2 \theta + \frac{GJ}{EI} b \sin^2 \theta \right)} \right) \quad (14b)$$

$$\omega = \tau bL^3 \sin \theta \cos \theta (\sqrt{2}L \cos \theta + b) \left( \frac{1}{\sqrt{2}EI \left( 2L + b \cos^2 \theta + \frac{GJ}{EI} b \sin^2 \theta \right)} \right) \quad (14c)$$

The principal strains are  $2u/(\sqrt{2}L \cos \theta + b)$  and  $-2u/(\sqrt{2}L \cos \theta + b)$ , so the shear strain is  $\gamma = 4u/(\sqrt{2}L \cos \theta + b)$ . Since  $\tau = G_{xy}\gamma$ , then

$$\frac{1}{G_{xy}} = \frac{4u}{\tau (\sqrt{2}L \cos \theta + b)} = 4L \sin \theta \left\{ \frac{b}{EA} + \frac{L^3 \left[ EI(2L + 4b \cos^2 \theta) + GJb \sin^2 \theta \right]}{12EI \left[ EI(2L + b \cos^2 \theta) + GJb \sin^2 \theta \right]} \right\} \quad (15)$$

Rearranging equation (15), we obtain finally

$$G_{xy} = \frac{12EAI \left( 2L + b \cos^2 \theta + \frac{GJ}{EI} b \sin^2 \theta \right)}{H \left[ 12Ib \left( 2L + b \cos^2 \theta + \frac{GJ}{EI} b \sin^2 \theta \right) + AL^3 \left( 2L + 4b \cos^2 \theta + \frac{GJ}{EI} b \sin^2 \theta \right) \right]}$$

Note that when  $b = L$  and  $\theta = \pi/4$ , the expression for the shear compliance  $G_{xy}^{-1}$  reduces to

$$\frac{1}{G_{xy}} = \frac{2\sqrt{2}L^2}{EA} + \frac{\sqrt{2}L^4}{6EI} \left( \frac{8EI + GJ}{5EI + GJ} \right)$$

which is the expression obtained by Zhu, Knott, and Mills (1997) for isotropic foams.

## Concluding Remarks

The equation for the shear modulus for nonisotropic, open-celled foams in the plane transverse to the elongation (rise) direction was derived. The equation was derived using an elongated Kelvin foam model with the most general geometric description, one that requires specifying three unit cell dimensions to define its size and shape. The shear modulus is a function of the unit cell dimensions, the solid material Young's modulus  $E$  and shear modulus  $G$ , and the edge cross-section properties  $A$ ,  $I$ , and  $J$ . It can be shown that the shear modulus equation derived from the most general elongated Kelvin unit cell shape reduces to the relation derived by Zhu, Knott, and Mills (1997) for isotropic foams when the unit cell is equiaxed.

## References

- Dement'ev, A.G.; and Tarakanov, O.G.: Model Analysis of the Cellular Structure of Plastic Foams of the Polyurethane Type. *Mekhanika Polimerov* (translated from *Polymer Mechanics*), vol. 5, 1970, pp. 744–749.
- Gong, L.; Kyriakides, S.; and Jang, W.-Y.: Compressive Response of Open-Cell Foams. Part I: Morphology and Elastic Properties. *Int. J. Solids Struct.*, vol. 42, nos. 5–6, 2005, pp. 1355–1379.
- Sullivan, Roy M.; Ghosn, Louis J.; and Lerch, Bradley A.: A General Tetrakaidecahedron Model for Open-Celled Foams. *Int. J. Solids Struct.*, vol. 45, no. 6, 2008, pp. 1754–1765.
- Thomson, William (Lord Kelvin): On the Division of Space With Minimum Partitional Area. *Phil. Mag.*, vol. 24, no. 151, 1887, p. 503.
- Warren, W.E.; and Kraynik, A.M.: Linear Elastic Behavior of a Low-Density Kelvin Foam With Open Cells. *J. Appl. Mech. Trans. ASME*, vol. 64, no. 4, 1997, pp. 787–794.
- Zhu, H.X.; Knott, J.F.; and Mills, N.J.: Analysis of the Elastic Properties of Open-Cell Foams With Tetrakaidecahedral Cells. *J. Mech. Phys. Solids*, vol. 45, no. 3, 1997, pp. 319–343.

**REPORT DOCUMENTATION PAGE**

*Form Approved*  
*OMB No. 0704-0188*

The public reporting burden for this collection of information is estimated to average 1 hour per response, including the time for reviewing instructions, searching existing data sources, gathering and maintaining the data needed, and completing and reviewing the collection of information. Send comments regarding this burden estimate or any other aspect of this collection of information, including suggestions for reducing this burden, to Department of Defense, Washington Headquarters Services, Directorate for Information Operations and Reports (0704-0188), 1215 Jefferson Davis Highway, Suite 1204, Arlington, VA 22202-4302. Respondents should be aware that notwithstanding any other provision of law, no person shall be subject to any penalty for failing to comply with a collection of information if it does not display a currently valid OMB control number.

PLEASE DO NOT RETURN YOUR FORM TO THE ABOVE ADDRESS.

<b>1. REPORT DATE (DD-MM-YYYY)</b> 01-11-2008		<b>2. REPORT TYPE</b> Technical Memorandum		<b>3. DATES COVERED (From - To)</b>	
<b>4. TITLE AND SUBTITLE</b> Shear Modulus for Nonisotropic, Open-Celled Foams Using a General Elongated Kelvin Foam Model				<b>5a. CONTRACT NUMBER</b>	
				<b>5b. GRANT NUMBER</b>	
				<b>5c. PROGRAM ELEMENT NUMBER</b>	
<b>6. AUTHOR(S)</b> Sullivan, Roy, M.; Ghosn, Louis, J.				<b>5d. PROJECT NUMBER</b>	
				<b>5e. TASK NUMBER</b>	
				<b>5f. WORK UNIT NUMBER</b> WBS 377816.06.02.02.03	
<b>7. PERFORMING ORGANIZATION NAME(S) AND ADDRESS(ES)</b> National Aeronautics and Space Administration John H. Glenn Research Center at Lewis Field Cleveland, Ohio 44135-3191				<b>8. PERFORMING ORGANIZATION REPORT NUMBER</b> E-16613	
<b>9. SPONSORING/MONITORING AGENCY NAME(S) AND ADDRESS(ES)</b> National Aeronautics and Space Administration Washington, DC 20546-0001				<b>10. SPONSORING/MONITORS ACRONYM(S)</b> NASA	
				<b>11. SPONSORING/MONITORING REPORT NUMBER</b> NASA/TM-2008-215430	
<b>12. DISTRIBUTION/AVAILABILITY STATEMENT</b> Unclassified-Unlimited Subject Categories: 27 and 39 Available electronically at <a href="http://gltrs.grc.nasa.gov">http://gltrs.grc.nasa.gov</a> This publication is available from the NASA Center for AeroSpace Information, 301-621-0390					
<b>13. SUPPLEMENTARY NOTES</b>					
<b>14. ABSTRACT</b> An equation for the shear modulus for nonisotropic, open-celled foams in the plane transverse to the elongation (rise) direction is derived using an elongated Kelvin foam model with the most general geometric description. The shear modulus was found to be a function of the unit cell dimensions, the solid material properties, and the cell edge cross-section properties. The shear modulus equation reduces to the relation derived by others for isotropic foams when the unit cell is equiaxed.					
<b>15. SUBJECT TERMS</b> Foam material; Polymer foam; Nonisotropic; Elongated tetrakaidecahedron (Kelvin) model					
<b>16. SECURITY CLASSIFICATION OF:</b>			<b>17. LIMITATION OF ABSTRACT</b>	<b>18. NUMBER OF PAGES</b>	<b>19a. NAME OF RESPONSIBLE PERSON</b>
<b>a. REPORT</b>	<b>b. ABSTRACT</b>	<b>c. THIS PAGE</b>			STI Help Desk (email:help@sti.nasa.gov)
U	U	U	UU	16	<b>19b. TELEPHONE NUMBER (include area code)</b> 301-621-0390





