

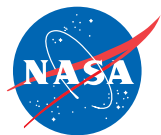







12-08

December 2008



TECH BRIEFS

NATIONAL AERONAUTICS AND SPACE ADMINISTRATION

-  Technology Focus
-  Electronics/Computers
-  Software
-  Materials
-  Mechanics/Machinery
-  Manufacturing
-  Bio-Medical
-  Physical Sciences
-  Information Sciences
-  Books and Reports

INTRODUCTION

Tech Briefs are short announcements of innovations originating from research and development activities of the National Aeronautics and Space Administration. They emphasize information considered likely to be transferable across industrial, regional, or disciplinary lines and are issued to encourage commercial application.

Availability of NASA Tech Briefs and TSPs

Requests for individual Tech Briefs or for Technical Support Packages (TSPs) announced herein should be addressed to

National Technology Transfer Center

Telephone No. **(800) 678-6882** or via World Wide Web at <http://www.nttc.edu/about/contactus.asp>

Please reference the control numbers appearing at the end of each Tech Brief. Information on NASA's Innovative Partnerships Program (IPP), its documents, and services is also available at the same facility or on the World Wide Web at <http://ipp.nasa.gov>.

Innovative Partnerships Offices are located at NASA field centers to provide technology-transfer access to industrial users. Inquiries can be made by contacting NASA field centers listed below.

NASA Field Centers and Program Offices

Ames Research Center
Lisa L. Lockyer
(650) 604-1754
lisa.l.lockyer@nasa.gov

Dryden Flight Research Center
Gregory Poteat
(661) 276-3872
greg.poteat@dfrc.nasa.gov

Glenn Research Center
Kathy Needham
(216) 433-2802
kathleen.k.needham@nasa.gov

Goddard Space Flight Center
Nona Cheeks
(301) 286-5810
nona.k.cheeks@nasa.gov

Jet Propulsion Laboratory
Ken Wolfenbarger
(818) 354-3821
james.k.wolfenbarger@jpl.nasa.gov

Johnson Space Center
Michele Brekke
(281) 483-4614
michele.a.brekke@nasa.gov

Kennedy Space Center
David R. Makufka
(321) 867-6227
david.r.makufka@nasa.gov

Langley Research Center
Martin Waszak
(757) 864-4015
martin.r.waszak@nasa.gov

Marshall Space Flight Center
Jim Dowdy
(256) 544-7604
jim.dowdy@msfc.nasa.gov

Stennis Space Center
John Bailey
(228) 688-1660
john.w.bailey@nasa.gov

Carl Ray, Program Executive
Small Business Innovation
Research (SBIR) & Small
Business Technology
Transfer (STTR) Programs
(202) 358-4652
carl.g.ray@nasa.gov

Doug Comstock, Director
Innovative Partnerships
Program Office
(202) 358-2560
doug.comstock@nasa.gov

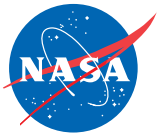

TECH BRIEFS

NATIONAL AERONAUTICS AND SPACE ADMINISTRATION



Technology Focus: Data Acquisition

- 5 Crew Activity Analyzer
- 6 Distributing Data to Hand-Held Devices in a Wireless Network
- 6 Reducing Surface Clutter in Cloud Profiling Radar Data
- 7 MODIS Atmospheric Data Handler
- 7 Multibeam Altimeter Navigation Update Using Faceted Shape Model



9 Electronics/Computers

- 9 Spaceborne Hybrid-FPGA System for Processing FTIR Data
- 9 FPGA Coprocessor for Accelerated Classification of Images
- 9 SiC JFET Transistor Circuit Model for Extreme Temperature Range
- 10 TDR Using Autocorrelation and Varying-Duration Pulses
- 10 Update on Development of SiC Multi-Chip Power Modules
- 11 Radio Ranging System for Guidance of Approaching Spacecraft
- 11 Electromagnetically Clean Solar Arrays
- 12 Improved Short-Circuit Protection for Power Cells in Series
- 12 Electromagnetically Clean Solar Arrays
- 13 Logic Gates Made of N-Channel JFETs and Epitaxial Resistors
- 14 Improved Short-Circuit Protection for Power Cells in Series
- 14 Communication Limits Due to Photon-Detector Jitter



15 Manufacturing & Prototyping

- 15 System for Removing Pollutants From Incinerator Exhaust
- 15 Sealing and External Sterilization of a Sample Container



17 Software

- 17 Converting EOS Data From HDF-EOS to netCDF
- 17 HDF-EOS 2 and HDF-EOS 5 Compatibility Library
- 17 HDF-EOS Web Server
- 17 HDF-EOS 5 Validator
- 17 XML DTD and Schemas for HDF-EOS

- 18 Converting From XML to HDF-EOS
- 18 Simulating Attitudes and Trajectories of Multiple Spacecraft
- 18 Specialized Color Function for Display of Signed Data
- 18 Delivering Alert Messages to Members of a Work Force
- 18 Delivering Images for Mars Rover Science Planning



21 Materials

- 21 Oxide Fiber Cathode Materials for Rechargeable Lithium Cells
- 21 Electrocatalytic Reduction of Carbon Dioxide to Methane
- 21 Heterogeneous Superconducting Low-Noise Sensing Coils
- 22 Progress Toward Making Epoxy/Carbon-Nanotube Composites
- 22 Predicting Properties of Unidirectional-Nanofiber Composites



23 Mechanics/Machinery

- 23 Deployable Crew Quarters
- 23 Nonventing, Regenerable, Lightweight Heat Absorber
- 23 Miniature High-Force, Long-Stroke SMA Linear Actuators
- 24 "Bootstrap" Configuration for Multistage Pulse-Tube Coolers
- 24 Reducing Liquid Loss During Ullage Venting in Microgravity



25 Books & Reports

- 25 Ka-Band Transponder for Deep-Space Radio Science
- 25 Replication of Space-Shuttle Computers in FPGAs and ASICs
- 25 Demisable Reaction-Wheel Assembly
- 25 Spatial and Temporal Low-Dimensional Models for Fluid Flow



27 Information Sciences

- 27 Advanced Land Imager Assessment System



29 Physical Sciences

- 29 Range Imaging Without Moving Parts

This document was prepared under the sponsorship of the National Aeronautics and Space Administration. Neither the United States Government nor any person acting on behalf of the United States Government assumes any liability resulting from the use of the information contained in this document, or warrants that such use will be free from privately owned rights.



Crew Activity Analyzer

Video, audio, and position data are recorded and analyzed.

Ames Research Center, Moffett Field, California

The crew activity analyzer (CAA) is a system of electronic hardware and software for automatically identifying patterns of group activity among crew members working together in an office, cockpit, workshop, laboratory, or other enclosed space. The CAA synchronously records multiple streams of data from digital video cameras, wireless microphones, and position sensors, then plays back and processes the data to identify activity patterns specified by human analysts. The processing greatly reduces the amount of time that the analysts must spend in examining large amounts of data, enabling the analysts to concentrate on subsets of data that represent activities of interest. The CAA has potential for use in a variety of governmental and commercial applications, including planning for crews for future long space flights, designing facilities

wherein humans must work in proximity for long times, improving crew training and measuring crew performance in military settings, human-factors and safety assessment, development of team procedures, and behavioral and ethnographic research.

The data-acquisition hardware of the CAA (see figure) includes two video cameras: an overhead one aimed upward at a paraboloidal mirror on the ceiling and one mounted on a wall aimed in a downward slant toward the crew area. As many as four wireless microphones can be worn by crew members. The audio signals received from the microphones are digitized, then compressed in preparation for storage. Approximate locations of as many as four crew members are measured by use of a Cricket indoor location system. [The Cricket indoor location system includes ultrasonic/radio

beacon and listener units. A Cricket beacon (in this case, worn by a crew member) simultaneously transmits a pulse of ultrasound and a radio signal that contains identifying information. Each Cricket listener unit measures the difference between the times of reception of the ultrasound and radio signals from an identified beacon. Assuming essentially instantaneous propagation of the radio signal, the distance between that beacon and the listener unit is estimated from this time difference and the speed of sound in air.] In this system, six Cricket listener units are mounted in various positions on the ceiling, and as many as four Cricket beacons are attached to crew members. The three-dimensional position of each Cricket beacon can be estimated from the time-difference readings of that beacon from at least three Cricket listener units.

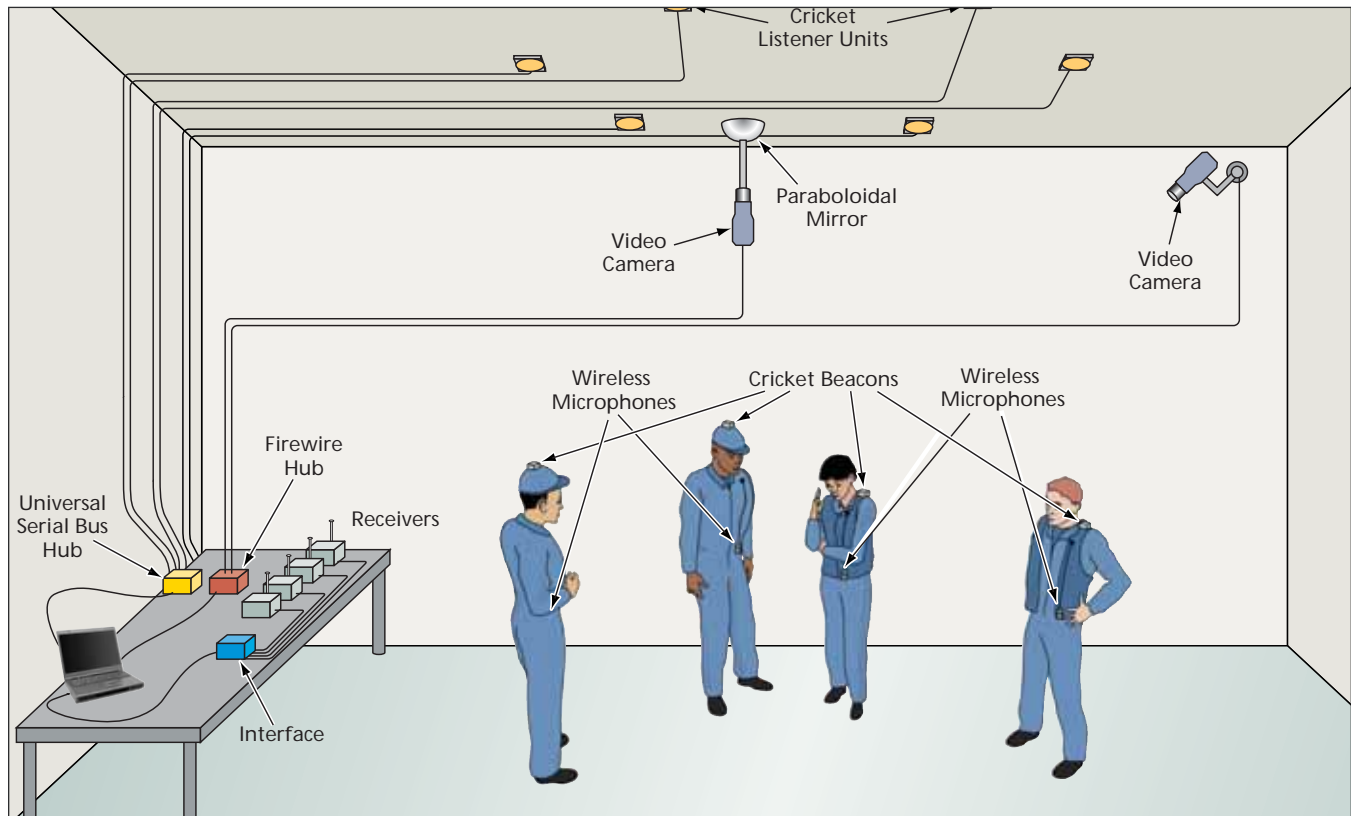

Activities of Crew Members Are Monitored by use of video cameras, microphones, and Cricket beacon and listener units. Monitor data are recorded, then played back and analyzed to identify patterns of group activity.

The CAA includes a notebook computer that controls the rest of the system and can be used to process the data upon playback. The CAA software includes components that separately capture the video, audio, and position data streams and store them in files on the hard drive of this computer. Alternatively or in addition, the data can be stored on one or more external hard drive(s) or on a digital videodisk. Data can be played back from any of these storage media. The CAA can store data for an observation interval as long as two weeks.

In addition to the video image data, the video-data-storage software component records the times of individual frames from each camera, enabling syn-

chronization of the video data with the audio and position data during playback and analysis. The position-data-storage software component reads data from the six Cricket listener units, calculates the three-dimensional positions of the Cricket beacons according to the principle described above, and saves these positions in a text file. The position-data-storage software component also creates, reads, and writes a Cricket calibration-data file.

The CAA software further includes components for playback and analysis of the recorded data. One of these software components provides capabilities for searching and playback using the video, audio, and position data files as well as files that describe rectangular areas of

interest (AOIs) on the floor as defined by the user with the help of another software component. Several other components perform a variety of analyses of image data. Still another software component reads the position and AOI data files and generates reports on activities of interest represented in the data (e.g., it generates histograms of occupation of AOIs by crew members). The data in the reports can be saved in a format suitable for export to a spreadsheet program.

This work was done by James Murray and Alexander Kirillov of Foster-Miller, Inc. for Ames Research Center. Inquiries concerning rights for the commercial use of this invention should be addressed to Judith Gertler, Division Manager, Foster-Miller Inc. at (781) 684-4270. Refer to ARC-15162-1.

● Distributing Data to Hand-Held Devices in a Wireless Network

Lyndon B. Johnson Space Center, Houston, Texas

ADROIT is a developmental computer program for real-time distribution of complex data streams for display on Web-enabled, portable terminals held by members of an operational team of a spacecraft-command-and-control center who may be located away from the center. Examples of such terminals include personal data assistants, laptop computers, and cellular telephones. ADROIT would make it unnecessary to equip each terminal with platform-specific software for access to the data streams or with software that implements the information-sharing protocol used to deliver telemetry data to clients in the center.

ADROIT is a combination of middleware plus software specific to the center. (Middleware enables one application program to communicate with another by performing such functions as conversion, translation, consolidation, and/or integration.) ADROIT translates a data stream (voice, video, or alphanumeric data) from the center into Extensible Markup Language, effectuates a subscription process to determine who gets what data when, and presents the data to each user in real time. Thus, ADROIT is expected to enable distribution of operations and to reduce the cost of operations by reducing the number of persons required to be in the center.

This program was written by Mark Hodges and Layne Simmons of TenXsys, Inc. for Johnson Space Center. For further information, contact the JSC Innovative Partnerships Office at (281) 483-3809.

In accordance with Public Law 96-517, the contractor has elected to retain title to this invention. Inquiries concerning rights for its commercial use should be addressed to:

*TenXsys, Inc.
408 S. Eagle Road
Suite 201
Eagle, ID 83616*

Refer to MSC-24152-1, volume and number of this NASA Tech Briefs issue, and the page number.

➤ Reducing Surface Clutter in Cloud Profiling Radar Data

Radar data can be processed to study clouds closer to the surface.

NASA's Jet Propulsion Laboratory, Pasadena, California

An algorithm has been devised to reduce ground clutter in the data products of the CloudSat Cloud Profiling Radar (CPR), which is a nadir-looking radar instrument, in orbit around the Earth, that measures power backscattered by clouds as a function of distance from the instrument. Ground clutter contaminates the CPR data in the lowest 1 km of the atmospheric profile, heretofore making it impossible to use

CPR data to satisfy the scientific interest in studying clouds and light rainfall at low altitude.

The algorithm is based partly on the fact that the CloudSat orbit is such that the geodetic altitude of the CPR varies continuously over a range of approximately 25 km. As the geodetic altitude changes, the radar timing parameters are changed at intervals defined by flight software in order to keep the tro-

posphere inside a data-collection time window. However, within each interval, the surface of the Earth continuously "scans through" (that is, it moves across) a few range bins of the data time window. For each radar profile, only few samples [one for every range-bin increment ($\Delta r = 240$ m)] of the surface-clutter signature are available around the range bin in which the peak of surface return is observed, but samples in con-

secutive radar profiles are offset slightly (by amounts much less than Δr) with respect to each other according to the relative change in geodetic altitude. As a consequence, in a case in which the surface area under examination is homogeneous (e.g., an ocean surface), a sequence of consecutive radar profiles of the surface in that area contains samples of the surface response with range resolution ($\Delta\rho$) much finer than the range-increment ($\Delta\rho \ll \Delta r$).

Once the high-resolution surface response has thus become available, the profile of surface clutter can be accurately estimated by use of a conventional maximum-correlation scheme: A trans-

lated and scaled version of the high-resolution surface response is fitted to the observed low-resolution profile. The translation and scaling factors that optimize the fit in a maximum-correlation sense represent (1) the true position of the surface relative to the sampled surface peak and (2) the magnitude of the surface backscatter.

The performance of this algorithm has been tested on CloudSat data acquired over an ocean surface. A preliminary analysis of the test data showed a surface-clutter-rejection ratio over flat surfaces of >10 dB and a reduction of the contaminated altitude over ocean from about 1 km to about 0.5 km (over the ocean).

The algorithm has been embedded in CloudSat L1B processing as of Release 04 (July 2007), and the estimated flat surface clutter is removed in L2B-GEOPROF product from the observed profile of reflectivity (see CloudSat product documentation for details and performance at <http://www.cloudsat.cira.colostate.edu/dataSpecs.php?prodid=1>).

This work was done by Simone Tanelli, Kyung Pak, Stephen Durden, and Eastwood Im of Caltech for NASA's Jet Propulsion Laboratory.

The software used in this innovation is available for commercial licensing. Please contact Karina Edmonds of the California Institute of Technology at (626) 395-2322. Refer to NPO-44873.

➤ MODIS Atmospheric Data Handler

Stennis Space Center, Mississippi

A number of science data sets are derived from the observations of the Moderate Resolution Imaging Spectroradiometer (MODIS) instrument onboard NASA's Terra and Aqua satellites. These data typically contain information on retrieval techniques, quality-control flags, and geo-referencing information. These datasets, distributed in HDF (Hierarchical Data Format), must be further processed to extract relevant information for weather analysis studies and numerical models input. The MODIS-Atmosphere Data Handler software converts the HDF data to ASCII format, and outputs: (1) atmospheric profiles

of temperature and dew point and (2) total precipitable water. Quality-control data are also considered in the export procedure.

The package currently consists of programs to process the MOD05 and MOD07 data products from MODIS. The software is written using the C programming language and contains Makefiles for easier compilation and installation. The MODIS-ADH software helps ease the overhead involved in data processing so that the numerical modelers may concentrate on their science and modeling tasks rather than manipulating data for their models.

This program was written by Valentine Anantharaj and Patrick Fitzpatrick of the Northern Gulf Institute at Mississippi State University for Stennis Space Center.

Inquiries concerning rights for its commercial use should be addressed to:

*Mississippi State University
Northern Gulf Institute
BLDG 1103, Room 233
Stennis Space Center, MS 39529
Phone No.: (228) 688-1157
Fax: (228) 688-7100
E-mail: val@gri.msstate.edu*

Refer to SSC-00267, volume and number of this NASA Tech Briefs issue, and the page number.

➤ Multibeam Altimeter Navigation Update Using Faceted Shape Model

The model is applicable to a body having almost any complex shape.

NASA's Jet Propulsion Laboratory, Pasadena, California

A method of incorporating information, acquired by a multibeam laser or radar altimeter system, pertaining to the distance and direction between the system and a nearby target body, into an estimate of the state of a vehicle upon which the system is mounted, involves the use of a faceted model to represent the shape of the target body. In the original intended application, the vehicle would be a spacecraft and the target body would be an asteroid, comet, or similar body that the spacecraft was required to approach. The method could

also be used in navigating aircraft at low altitudes over terrain that is rough and/or occupied by objects of significant structure.

Fundamentally, what one seeks to measure is the distance from the vehicle to the target body. The present method is the product of a generalization of a prior method of altimetry, in which the target body has a simple shape represented by a spherical or ellipsoidal model. In principle, the estimate of distance or altitude obtained by use of a multibeam altimeter can be more robust

than that obtained by use of a single-beam altimeter, but if the surface of the target body has a complex and/or irregular shape, then it becomes more difficult to define the distance and compute the distance from readings of a multibeam altimeter.

The faceted shape model of the present method facilitates the definition and computation of distance to a target object having almost any shape, no matter how irregular and complex. The use of faceted shape models to represent complex three-dimensional objects is com-

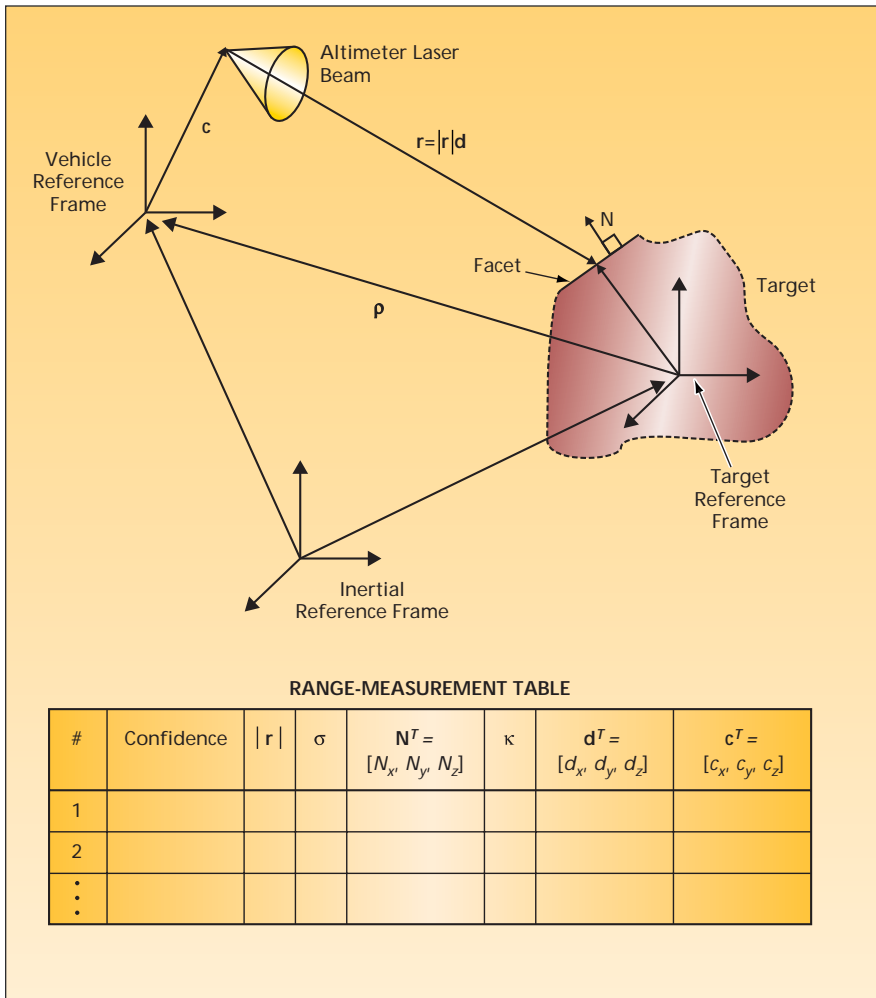

The Laser or Radar Altimeter measures the magnitude of the vector (r) from the origin of each beam to the intersection of the beam with a target body represented by a multifaceted shape model. There are multiple beams, but only one is shown here for simplicity. The measurement data and associated model data are listed in the range-measurement table.

mon in the computer-graphics literature and in the movie and video-game industries. In this method, the distance to be measured is defined as the length of the vector (ρ) from the center of mass of the multifaceted shape model to the center of mass of the vehicle, as depicted in the upper part of the figure.

The state-update information derived from the most recent set of multibeam-

altimeter measurements is listed systematically in a range-measurement table (RMT), depicted in the lower part of the figure, in which the planar facets of the shape model are represented in Hesse's normal form. Each row of the table contains the data from one of the altimeter beams. The first column contains the row index (i), which is the cardinal number of the affected beam. The second

column contains a number, between 0 and 1, representing the degree of confidence in the measurements. At the present state of development of the method, the confidence is taken to be either 0 (signifying complete rejection) or 1 (representing complete acceptance) of the data in the row. The third column contains the scalar range measurement $|r|$ of the i th beam; the fourth column contains the standard deviation (σ) of the range measurement.

The fifth column contains the Cartesian components $[N_x, N_y, N_z]$ of the transpose of the unit vector (N^T) normal to the model facet containing the intersection of the i th laser beam with the surface of the target object. Typically, this intersection point is not known exactly and must be estimated, on the basis of the current state estimate, by a previously developed method that lies beyond the scope of this article. The sixth column contains the facet constant, κ (the perpendicular distance from the center of mass of the target body to the affected facet). The seventh column contains the Cartesian components $[d_x, d_y, d_z]$ of the unit vector along the i th laser beam. The seventh column contains the Cartesian components $[c_x, c_y, c_z]$ of the position vector from the center of mass of the vehicle to the origin of the i th laser beam.

The entries in the RMT are mapped into a measurement equation for use by a Kalman filter that incorporates altimetry information into the final estimate of the state of a spacecraft or other vehicle maneuvering in the vicinity of a target body. The relative position vector, ρ , is part of the state vector that is updated by use of the Kalman filter.

This work was done by David S. Bayard, Paul Brugarolas, and Steve Broschart of Caltech for NASA's Jet Propulsion Laboratory. For more information, contact iaoffice@jpl.nasa.gov. NPO-44428



Spaceborne Hybrid-FPGA System for Processing FTIR Data

NASA's Jet Propulsion Laboratory, Pasadena, California

Progress has been made in a continuing effort to develop a spaceborne computer system for processing readout data from a Fourier-transform infrared (FTIR) spectrometer to reduce the volume of data transmitted to Earth. The approach followed in this effort, oriented toward reducing design time and reducing the size and weight of the spectrometer electronics, has been to exploit the versatility of recently developed hybrid field-programmable gate arrays (FPGAs) to run diverse software on embedded processors while also taking ad-

vantage of the reconfigurable hardware resources of the FPGAs.

The specific FPGA/embedded-processor combination selected for this effort is the Xilinx Virtex-4 FX hybrid FPGA with one of its two embedded IBM PowerPC 405 processors. The effort has involved exploration of various architectures and hardware and software optimizations. By including a dedicated floating-point unit and a dot-product coprocessor in the hardware and utilizing optimized single-precision math library functions and a modified PowerPC performance library

in the software, it has been possible to reduce execution time to an eighth of that of a non-optimized software-only implementation. A concept for utilizing both embedded PowerPC processors to further reduce execution time has also been considered.

This work was done by Dmitriy L. Bekker, Jean-Francois L. Blavier, and Paula J. Pingree of Caltech and Marcin Lukowiak and Muhammad Shaaban of Rochester Institute of Technology for NASA's Jet Propulsion Laboratory. For more information, contact iaoffice@jpl.nasa.gov. NPO-45957

FPGA Coprocessor for Accelerated Classification of Images

NASA's Jet Propulsion Laboratory, Pasadena, California

An effort related to that described in the preceding article focuses on developing a spaceborne processing platform for fast and accurate onboard classification of image data, a critical part of modern satellite image processing. The approach again has been to exploit the versatility of recently developed hybrid Virtex-4FX field-programmable gate array (FPGA) to run diverse science applications on embedded processors while taking advantage of the reconfigurable hardware resources of the FPGAs. In this case, the FPGA serves as a coprocessor that implements legacy C-language support-vector-machine (SVM) image-classification algorithms to detect and identify natural

phenomena such as flooding, volcanic eruptions, and sea-ice break-up. The FPGA provides hardware acceleration for increased onboard processing capability than previously demonstrated in software.

The original C-language program — demonstrated on an imaging instrument aboard the Earth Observing-1 (EO-1) satellite — implements a linear-kernel SVM algorithm for classifying parts of the images as snow, water, ice, land, or cloud or unclassified. Current onboard processors, such as on EO-1, have limited computing power, extremely limited active storage capability and are no longer considered state-of-the-art. Using commercially available software

that translates C-language programs into hardware description language (HDL) files, the legacy C-language program, and two newly formulated programs for a more capable expanded-linear-kernel and a more accurate polynomial-kernel SVM algorithm, have been implemented in the Virtex-4FX FPGA. In tests, the FPGA implementations have exhibited significant speedups over conventional software implementations running on general-purpose hardware.

This work was done by Paula J. Pingree, Lucas J. Scharenbroich, and Thomas A. Werne of Caltech for NASA's Jet Propulsion Laboratory. For more information, contact iaoffice@jpl.nasa.gov. NPO-45961

SiC JFET Transistor Circuit Model for Extreme Temperature Range

Simple modifications of common silicon model provide reasonable approximation from 25 to 500 °C.

John H. Glenn Research Center, Cleveland, Ohio

A technique for simulating extreme-temperature operation of integrated circuits that incorporate silicon carbide (SiC) junction field-effect transistors (JFETs) has been developed. The technique involves modification of NGSPICE, which is an open-source version of the popular Simulation Program

with Integrated Circuit Emphasis (SPICE) general-purpose analog-integrated-circuit-simulating software. NGSPICE in its unmodified form is used for simulating and designing circuits made from silicon-based transistors that operate at or near room temperature.

Two rapid modifications of NGSPICE

source code enable SiC JFETs to be simulated to 500 °C using the well-known "Level 1" model for silicon metal oxide semiconductor field-effect transistors (MOSFETs). First, the default value of the MOSFET surface potential must be changed. In the unmodified source code, this parameter has a value of 0.6,

which corresponds to slightly more than half the bandgap of silicon. In NGSPICE modified to simulate SiC JFETs, this parameter is changed to a value of 1.6, corresponding to slightly more than half the bandgap of SiC. The second modification consists of changing the temperature dependence of MOSFET transconductance and saturation parameters. The unmodified NGSPICE source code implements a $T^{-1.5}$ temperature dependence for these parameters. In order to mimic the temperature behavior of ex-

perimental SiC JFETs, a $T^{-1.3}$ temperature dependence must be implemented in the NGSPICE source code.

Following these two simple modifications, the "Level 1" MOSFET model of the NGSPICE circuit simulation program reasonably approximates the measured high-temperature behavior of experimental SiC JFETs properly operated with zero or reverse bias applied to the gate terminal. Modification of additional silicon parameters in the NGSPICE source code was not neces-

sary to model experimental SiC JFET current-voltage performance across the entire temperature range from 25 to 500 °C.

This work was done by Philip G. Neudeck of Glenn Research Center. Further information is contained in a TSP (see page 1).

Inquiries concerning rights for the commercial use of this invention should be addressed to NASA Glenn Research Center, Innovative Partnerships Office, Attn: Steve Fedor, Mail Stop 4-8, 21000 Brookpark Road, Cleveland, Ohio 44135. Refer to LEW-18342-1.

TDR Using Autocorrelation and Varying-Duration Pulses

Signal-to-noise ratios may be increased.

John F. Kennedy Space Center, Florida

In an alternative to a prior technique of time-domain-reflectometry (TDR) in which very short excitation pulses are used, the pulses have very short rise and fall times and the pulse duration is varied continuously between a minimum and a maximum value. In both the present and prior techniques, the basic idea is to (1) measure the times between the generation of excitation pulses and the reception of reflections of the pulses as indications of the locations of one or more defects along a cable and (2) measure the amplitudes of the reflections as indication of the magnitudes of the defects.

In general, an excitation pulse has a duration T . Each leading and trailing

edge of an excitation pulse generates a reflection from a defect, so that a unique pair of reflections is associated with each defect. In the present alternative technique, the processing of the measured reflection signal includes computation of the autocorrelation function

$$R(\tau) \equiv \int x(t)x(t-\tau) dt$$

where t is time, $x(t)$ is the measured reflection signal at time t , and τ is the correlation interval. The integration is performed over a measurement time interval short enough to enable identification and location of a defect within the corresponding spatial interval along the cable. Typically, where there is a defect, $R(\tau)$ exhibits a negative peak having maximum magnitude for τ in the vicinity of T . This peak

can be used as a means of identifying a leading-edge/trailing-edge reflection pair.

For a given spatial interval, measurements are made and $R(\tau)$ computed, as described above, for pulse durations T ranging from the minimum to the maximum value. The advantage of doing this is that the effective signal-to-noise ratio may be significantly increased over that attainable by use of a fixed pulse duration T .

This work was done by Angel Lucena, Pam Mullinex, PoTien Huang, and Josephine Santiago of Kennedy Space Center and Pedro Medelius, Carlos Mata, Carlos Zavala, and John Lane of ASRC Aerospace Corp. Further information is contained in a TSP (see page 1). KSC-12856

Update on Development of SiC Multi-Chip Power Modules

Modules and a modular power system have been built and tested.

John H. Glenn Research Center, Cleveland, Ohio

Progress has been made in a continuing effort to develop multi-chip power modules (SiC MCPMs). This effort at an earlier stage was reported in "SiC Multi-Chip Power Modules as Power-System Building Blocks" (LEW-18008-1), *NASA Tech Briefs*, Vol. 31, No. 2 (February 2007), page 28.

The following unavoidably lengthy recapitulation of information from the cited prior article is prerequisite to a meaningful summary of the progress made since then:

- SiC MCPMs are, more specifically, electronic power-supply modules containing multiple silicon carbide power integrated-circuit chips and silicon-on-insulator

(SOI) control integrated-circuit chips. SiC MCPMs are being developed as building blocks of advanced expandable, reconfigurable, fault-tolerant power-supply systems. Exploiting the ability of SiC semiconductor devices to operate at temperatures, breakdown voltages, and current densities significantly greater than those of conventional Si devices, the designs of SiC MCPMs and of systems comprising multiple SiC MCPMs are expected to afford a greater degree of miniaturization through stacking of modules with reduced requirements for heat sinking.

- The stacked SiC MCPMs in a given sys-

tem can be electrically connected in series, parallel, or a series/parallel combination to increase the overall power-handling capability of the system. In addition to power connections, the modules have communication connections. The SOI controllers in the modules communicate with each other as nodes of a decentralized control network, in which no single controller exerts overall command of the system. Control functions effected via the network include synchronization of switching of power devices and rapid reconfiguration of power connections to

enable the power system to continue to supply power to a load in the event of failure of one of the modules.

- In addition to serving as building blocks of reliable power-supply systems, SiC MCPMs could be augmented with external control circuitry to make them perform additional power-handling functions as needed for specific applications. Because identical SiC MCPM building blocks could be utilized in such a variety of ways, the cost and difficulty of designing new, highly reliable power systems would be reduced considerably. This concludes the information from the cited prior article.

The main activity since the previously reported stage of development was the design, fabrication, and testing a 120-

VDC-to-28-VDC modular power-converter system composed of eight SiC MCPMs in a 4 (parallel)-by-2 (series) matrix configuration, with normally-off controllable power switches. The SiC MCPM power modules include closed-loop control subsystems and are capable of operating at high power density or high temperature. The system was tested under various configurations, load conditions, load-transient conditions, and failure-recovery conditions.

Planned future work includes refinement of the demonstrated modular system concept and development of a new converter hardware topology that would enable sharing of currents without the need for communication among modules. Toward these ends, it is also

planned to develop a new converter control algorithm that would provide for improved sharing of current and power under all conditions, and to implement advanced packaging concepts that would enable operation at higher power density.

This work was done by Alexander Lostetter, Edgar Cilio, Gavin Mitchell, and Roberto Schupbach of Arkansas Power Electronics International, Inc. for Glenn Research Center. Further information is contained in a TSP (see page 1).

Inquiries concerning rights for the commercial use of this invention should be addressed to NASA Glenn Research Center, Innovative Partnerships Office, Attn: Steve Fedor, Mail Stop 4-8, 21000 Brookpark Road, Cleveland, Ohio 44135. Refer to LEW-18341-1.

Radio Ranging System for Guidance of Approaching Spacecraft

Lyndon B. Johnson Space Center, Houston, Texas

A radio communication and ranging system has been proposed for determining the relative position and orientations of two approaching spacecraft to provide guidance for docking maneuvers. On Earth, the system could be used similarly for guiding approaching aircraft and for automated positioning of large, heavy objects. In principle, the

basic idea is to (1) measure distances between radio transceivers on the two spacecraft and (2) compute the relative position and orientations from the measured distances.

Half-duplex communication links would be established between transceivers on the two spacecraft, and pulses having durations of the order of a nanosecond

would be exchanged. The distances would be determined by the pulse-time-of-flight method. Data signals could be transmitted in addition to ranging pulses.

This work was done by Vikram Manikonda and Eric van Doorn of Intelligent Automation, Inc. for Johnson Space Center. For further information, contact the JSC Innovation Partnerships Office at (281) 483-3809. MSC-23474-1

Electromagnetically Clean Solar Arrays

Cells are laminated with shielding, narrow-current-loop wiring, and structural supports.

John H. Glenn Research Center, Cleveland, Ohio

The term “electromagnetically clean solar array” (“EMCSA”) refers to a panel that contains a planar array of solar photovoltaic cells and that, in comparison with a functionally equivalent solar-array panel of a type heretofore used on spacecraft, (1) exhibits less electromagnetic interference to and from other nearby electrical and electronic equipment and (2) can be manufactured at lower cost. The reduction of electromagnetic interference is effected through a combination of (1) electrically conductive, electrically grounded shielding and (2) reduction of areas of current loops (in order to reduce magnetic moments). The reduction of cost is effected by designing the array to be fabricated as a more nearly unitary structure, using fewer components and fewer process steps. Although EMCSAs

were conceived primarily for use on spacecraft, they are also potentially advantageous for terrestrial applications in which there are requirements to limit electromagnetic interference.

In a conventional solar panel of the type meant to be supplanted by an EMCSA panel, the wiring is normally located on the back side, separated from the cells, thereby giving rise to current loops having significant areas and, consequently, significant magnetic moments. Current-loop geometries are chosen in an effort to balance opposing magnetic moments to limit far-field magnetic interactions, but the relatively large distances separating current loops makes full cancellation of magnetic fields problematic. The panel is assembled from bare photovoltaic cells by means of multiple sensitive process steps that con-

tribute significantly to cost, especially if electromagnetic cleanliness is desired. The steps include applying a cover glass and electrical-interconnection tabs to each cell to create a cell-interconnect-cell (CIC) sub-assembly, connecting the CIC subassemblies into strings of series-connected cells, laying down and adhesively bonding the strings onto a panel structure that has been made in a separate multi-step process, and mounting the wiring on the back of the panel. Each step increases the potential for occurrence of latent defects, loss of process control, and attrition of components.

An EMCSA panel includes an integral cover made from a transparent silicone material. The silicone cover supplants the individual cover glasses on the cells and serves as an additional unitary structural support that offers the advantage, relative

to glass, of the robust, forgiving nature of the silicone material. The cover contains pockets that hold the solar cells in place during the lamination process. The cover is coated with indium tin oxide to make its surface electrically conductive, so that it serves as a contiguous, electrically grounded electromagnetic shield over the entire panel surface.

The cells are mounted in proximity to metallic printed wiring. The printed-wiring layer comprises metal-film traces on a sheet of Kapton (or equivalent) polyimide. The traces include contact pads on one side of the sheet for interconnecting the cells. Return leads are on the opposite side of the

sheet, positioned to form the return currents substantially as mirror images of, and in proximity to, the cell sheet currents, thereby minimizing magnetic moments. The printed-wiring arrangement mimics the back-wiring arrangement of conventional solar arrays, but the current-loop areas and the resulting magnetic moments are much smaller because the return-current paths are much closer to the solar-cell sheet currents.

The contact pads are prepared with solder for electrical and mechanical bonding to the cells. The pocketed cover/shield, the solar cells, the printed-wiring layer, an electrical-bonding agent,

a mechanical-bonding agent, a composite structural front-side face sheet, an aluminum honeycomb core, and a composite back-side face sheet are all assembled, then contact pads are soldered to the cells and the agents are cured in a single lamination process.

This work was done by Theodore G. Stern and Anthony E. Kenniston of DR Technologies, Inc. for Glenn Research Center.

Inquiries concerning rights for the commercial use of this invention should be addressed to NASA Glenn Research Center, Innovative Partnerships Office, Attn: Steve Fedor, Mail Stop 4-8, 21000 Brookpark Road, Cleveland, Ohio 44135. Refer to LEW-18156-1.

Improved Short-Circuit Protection for Power Cells in Series

Lyndon B. Johnson Space Center, Houston, Texas

A scheme for protection against short circuits has been devised for series strings of lithium electrochemical cells that contain built-in short-circuit protection devices, which go into a high-resistance, current-limiting state when heated by excessive current. If cells are simply connected in a long series string to obtain a high voltage and a short circuit occurs, whichever short-circuit protection device trips first is exposed to nearly the full string voltage, which, typically, is

large enough to damage the device. Depending on the specific cell design, the damage can defeat the protective function, cause a dangerous internal short circuit in the affected cell, and/or cascade to other cells.

In the present scheme, reverse diodes rated at a suitably high current are connected across short series sub-strings, the lengths of which are chosen so that when a short-circuit protection device is tripped, the voltage across it

does not exceed its rated voltage. This scheme preserves the resetting properties of the protective devices. It provides for bypassing of cells that fail open and limits cell reversal, though not as well as does the more-expensive scheme of connecting a diode across every cell.

This work was done by Francis Davies of Hernandez Engineering Inc. for Johnson Space Center. Further information is contained in a TSP (see page 1). MSC-23446-1

Electromagnetically Clean Solar Arrays

Cells are laminated with shielding, narrow-current-loop wiring, and structural supports.

John H. Glenn Research Center, Cleveland, Ohio

The term "electromagnetically clean solar array" ("EMCSA") refers to a panel that contains a planar array of solar photovoltaic cells and that, in comparison with a functionally equivalent solar-array panel of a type heretofore used on spacecraft, (1) exhibits less electromagnetic interference to and from other nearby electrical and electronic equipment and (2) can be manufactured at lower cost. The reduction of electromagnetic interference is effected through a combination of (1) electrically conductive, electrically grounded shielding and (2) reduction of areas of current loops (in order to reduce magnetic moments). The reduction of cost is effected by designing the array to be fabricated as a more nearly unitary structure, using fewer components and

fewer process steps. Although EMSCAs were conceived primarily for use on spacecraft, they are also potentially advantageous for terrestrial applications in which there are requirements to limit electromagnetic interference.

In a conventional solar panel of the type meant to be supplanted by an EMCSA panel, the wiring is normally located on the back side, separated from the cells, thereby giving rise to current loops having significant areas and, consequently, significant magnetic moments. Current-loop geometries are chosen in an effort to balance opposing magnetic moments to limit far-field magnetic interactions, but the relatively large distances separating current loops makes full cancellation of magnetic fields problematic. The panel is assembled

from bare photovoltaic cells by means of multiple sensitive process steps that contribute significantly to cost, especially if electromagnetic cleanliness is desired. The steps include applying a cover glass and electrical-interconnection tabs to each cell to create a cell-interconnect-cell (CIC) sub-assembly, connecting the CIC subassemblies into strings of series-connected cells, laying down and adhesively bonding the strings onto a panel structure that has been made in a separate multi-step process, and mounting the wiring on the back of the panel. Each step increases the potential for occurrence of latent defects, loss of process control, and attrition of components.

An EMCSA panel includes an integral cover made from a transparent silicone material. The silicone cover supplants the

individual cover glasses on the cells and serves as an additional unitary structural support that offers the advantage, relative to glass, of the robust, forgiving nature of the silicone material. The cover contains pockets that hold the solar cells in place during the lamination process. The cover is coated with indium tin oxide to make its surface electrically conductive, so that it serves as a contiguous, electrically grounded electromagnetic shield over the entire panel surface.

The cells are mounted in proximity to metallic printed wiring. The printed-wiring layer comprises metal-film traces on a sheet of Kapton (or equivalent) polyimide. The traces include contact

pads on one side of the sheet for interconnecting the cells. Return leads are on the opposite side of the sheet, positioned to form the return currents substantially as mirror images of, and in proximity to, the cell sheet currents, thereby minimizing magnetic moments. The printed-wiring arrangement mimics the back-wiring arrangement of conventional solar arrays, but the current-loop areas and the resulting magnetic moments are much smaller because the return-current paths are much closer to the solar-cell sheet currents.

The contact pads are prepared with solder for electrical and mechanical bonding to the cells. The pocketed cover/shield,

the solar cells, the printed-wiring layer, an electrical-bonding agent, a mechanical-bonding agent, a composite structural front-side face sheet, an aluminum honeycomb core, and a composite back-side face sheet are all assembled, then contact pads are soldered to the cells and the agents are cured in a single lamination process.

This work was done by Theodore G. Stern and Anthony E. Kenniston of DR Technologies, Inc. for Glenn Research Center.

Inquiries concerning rights for the commercial use of this invention should be addressed to NASA Glenn Research Center, Innovative Partnerships Office, Attn: Steve Fedor, Mail Stop 4-8, 21000 Brookpark Road, Cleveland, Ohio 44135. Refer to LEW-18156-1.

Logic Gates Made of N-Channel JFETs and Epitaxial Resistors

Gates could be implemented in SiC ICs for operation at high temperatures.

John H. Glenn Research Center, Cleveland, Ohio

Prototype logic gates made of n-channel junction field-effect transistors (JFETs) and epitaxial resistors have been demonstrated, with a view toward eventual implementation of digital logic devices and systems in silicon carbide (SiC) integrated circuits (ICs). This development is intended to exploit the inherent ability of SiC electronic devices to function at temperatures from 300 to somewhat above 500 °C and withstand large doses of ionizing radiation. SiC-based

digital logic devices and systems could enable operation of sensors and robots in nuclear reactors, in jet engines, near hydrothermal vents, and in other environments that are so hot or radioactive as to cause conventional silicon electronic devices to fail.

At present, current needs for digital processing at high temperatures exceed SiC integrated circuit production capabilities, which do not allow for highly integrated circuits. Only single to small

number component production of depletion mode n-channel JFETs and epitaxial resistors on a single substrate is possible. As a consequence, the fine matching of components is impossible, resulting in rather large direct-current parameter distributions within a group of transistors typically spanning multiples of 5 to 10. Add to this the lack of p-channel devices to complement the n-channel FETs, the lack of precise dropping diodes, and the lack of en-

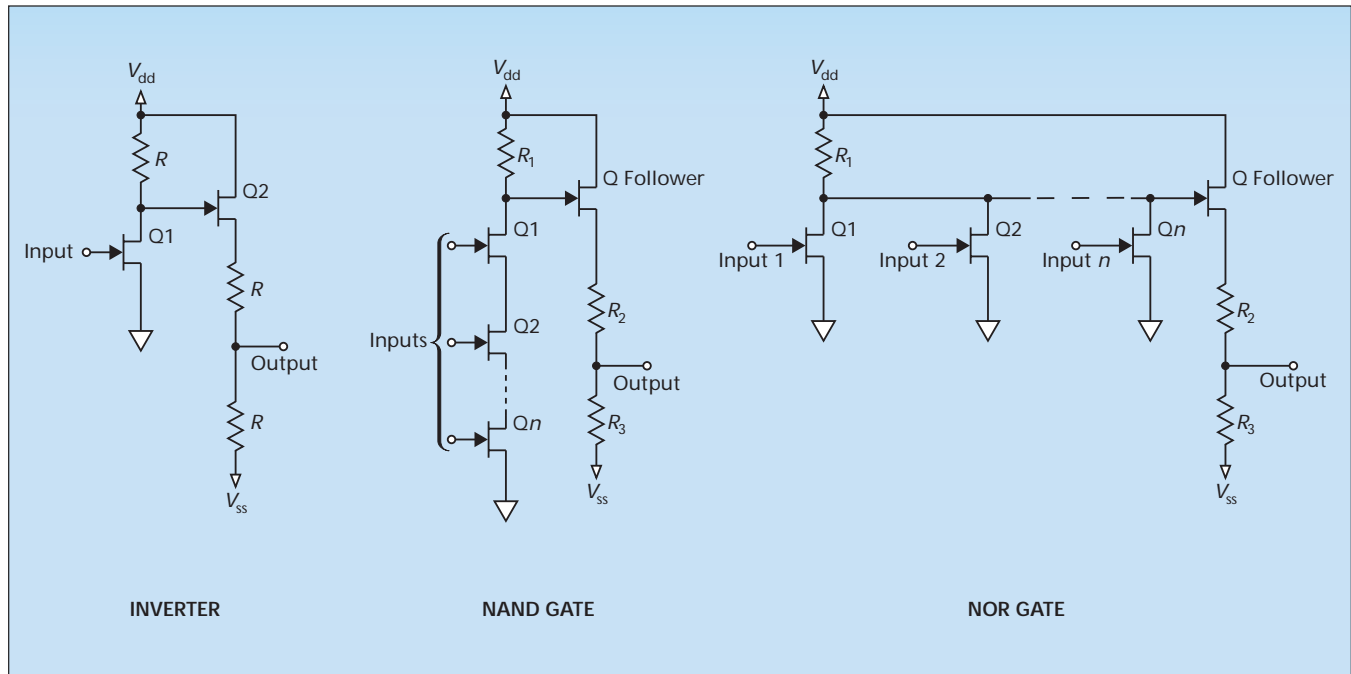

This Inverter, NAND Gate, and NOR Gate are examples of logic circuits designed according to the principles described in the text. Other gates having greater complexity have also been designed.

hancement mode devices at these elevated temperatures and the use of conventional direct coupled and buffered direct coupled logic gate design techniques is impossible.

The presented logic gate design is tolerant of device parameter distributions and is not hampered by the lack of complementary devices or dropping diodes. In addition to n-channel JFETs, these gates include level-shifting and load re-

sistors (see figure). Instead of relying on precise matching of parameters among individual JFETs, these designs rely on choosing the values of these resistors and of supply potentials so as to make the circuits perform the desired functions throughout the ranges over which the parameters of the JFETs are distributed. The supply rails V_{dd} and V_{ss} and the resistors R are chosen as functions of the distribution of direct-current op-

erating parameters of the group of transistors used.

This work was done by Michael J. Krawski of Glenn Research Center. Further information is contained in a TSP (see page 1).

Inquiries concerning rights for the commercial use of this invention should be addressed to NASA Glenn Research Center, Innovative Partnerships Office, Attn: Steve Fedor, Mail Stop 4-8, 21000 Brookpark Road, Cleveland, Ohio 44135. Refer to LEW-18256-1.

Improved Short-Circuit Protection for Power Cells in Series

Lyndon B. Johnson Space Center, Houston, Texas

A scheme for protection against short circuits has been devised for series strings of lithium electrochemical cells that contain built-in short-circuit protection devices, which go into a high-resistance, current-limiting state when heated by excessive current. If cells are simply connected in a long series string to obtain a high voltage and a short circuit occurs, whichever short-circuit protection device trips first is exposed to nearly the full string voltage, which, typically, is

large enough to damage the device. Depending on the specific cell design, the damage can defeat the protective function, cause a dangerous internal short circuit in the affected cell, and/or cascade to other cells.

In the present scheme, reverse diodes rated at a suitably high current are connected across short series substrings, the lengths of which are chosen so that when a short-circuit protection device is tripped, the voltage across it

does not exceed its rated voltage. This scheme preserves the resetting properties of the protective devices. It provides for bypassing of cells that fail open and limits cell reversal, though not as well as does the more-expensive scheme of connecting a diode across every cell.

This work was done by Francis Davies of Hernandez Engineering Inc. for Johnson Space Center. Further information is contained in a TSP (see page 1). MSC-23446-1

Communication Limits Due to Photon-Detector Jitter

NASA's Jet Propulsion Laboratory, Pasadena, California

A theoretical and experimental study was conducted of the limit imposed by photon-detector jitter on the capacity of a pulse-position-modulated optical communication system in which the receiver operates in a photon-counting (weak-signal) regime. Photon-detector jitter is a random delay between impingement of a photon and generation of an electrical pulse by the detector.

In the study, jitter statistics were computed from jitter measurements made on several photon detectors. The proba-

bility density of jitter was mathematically modeled by use of a weighted sum of Gaussian functions. Parameters of the model were adjusted to fit histograms representing the measured-jitter statistics. Likelihoods of assigning detector-output pulses to correct pulse time slots in the presence of jitter were derived and used to compute channel capacities and corresponding losses due to jitter.

It was found that the loss, expressed as the ratio between the signal power needed to achieve a specified capacity

in the presence of jitter and that needed to obtain the same capacity in the absence of jitter, is well approximated as a quadratic function of the standard deviation of the jitter in units of pulse-time-slot duration.

This work was done by Bruce E. Moision and William H. Farr of Caltech for NASA's Jet Propulsion Laboratory. For more information, contact iaoffice@jpl.nasa.gov. NPO-45809



System for Removing Pollutants From Incinerator Exhaust

Lyndon B. Johnson Space Center, Houston, Texas

A system for removing pollutants — primarily sulfur dioxide and mixed oxides of nitrogen (NO_x) — from incinerator exhaust has been demonstrated. The system is also designed secondarily to remove particles, hydrocarbons, and CO. The system is intended for use in an enclosed environment, for which a prior NO_x -and- SO_2 -removal system designed for industrial settings would not be suitable. The incinerator exhaust first encounters a cyclone separator, a primary heat exchanger, and a fabric filter that, together, remove particles and reduce the temperature to 500 °C. The exhaust then passes through a porous bed, main-

tained at ≈ 450 °C, that contains Na_2CO_3 , which absorbs SO_2 .

Next, a commercial catalyst maintained at 400 °C accelerates the oxidation of the carbon in hydrocarbons to CO and CO_2 . A heat exchanger then cools the exhaust to ≈ 300 °C before passage over a catalyst that causes 95 percent of the NO to be oxidized to NO_2 . The first of two water scrubbers removes most of the NO_2 , which is converted to KNO_3 and KNO_2 . The second water scrubber contains sodium bisulfite, which, with an aminophenol catalyst, converts most of the remaining NO_2 to N_2 .

This work was done by David T. Wickham, James Bahr, Rita Dubovik, Steven C. Gebhard, and Jeffrey Lind of TDA Research, Inc. for Johnson Space Center. For further information, contact the JSC Innovative Partnerships Office at (281) 483-3809.

In accordance with Public Law 96-517, the contractor has elected to retain title to this invention. Inquiries concerning rights for its commercial use should be addressed to:

*TDA Research
12345 West 52nd Ave.
Wheat Ridge, CO 80033*

Refer to MSC-23440-1, volume and number of this NASA Tech Briefs issue, and the page number.

Sealing and External Sterilization of a Sample Container

This method would enable safe transport of a biologically hazardous sample.

NASA's Jet Propulsion Laboratory, Pasadena, California

A method of (1) sealing a sample of material acquired in a possibly biologically contaminated (“dirty”) environment into a hermetic container, (2) sterilizing the outer surface of the container, then (3) delivering the sealed container to a clean environment has been proposed. This method incorporates the method reported in “Separation and Sealing of a Sample Container Using Brazing” (NPO-41024), *NASA Tech Briefs*, Vol. 31, No. 8 (August 2007), page 42. Like the previously reported method, the method now proposed was originally intended to be used to return samples from Mars to Earth, but could also be used on Earth to transport material samples acquired in environments that contain biological hazards and/or, in some cases, chemical hazards.

To recapitulate from the cited prior article: the process described therein is denoted “S³B” (separation, seaming, and sealing using brazing) because sealing of the sample into the hermetic container, separating the container from the dirty environment, and bringing the container with a clean outer surface into the clean environment are all accomplished simultaneously with an inductive-heating

brazing operation. At the beginning of the process, the sample container is the inner part of a double-wall container, and the inner and outer parts of the double-wall container are bonded together at a flange/braze joint at the top. By virtue of this configuration, the inside of the sample container is exposed to the dirty environment while the outer surface of the sample container is isolated from the dirty environment.

During the S³B process, a lid that is part of a barrier assembly between the dirty and clean environments becomes brazed onto the sample container, and the sample container with the lid attached becomes separated from the outer part of the double-wall container and is pushed into the clean environment. The brazing material is chosen to have a sufficiently high melting temperature (typically >500 °C) so that the brazing process sterilizes the outer surface of the lid/wall seam region of the newly created hermetic container. The outer surface of the inner container is covered with a layer of thermal-insulation material to prevent heat damage of the sample during brazing. Alternatively, in an application in which there is no concern about

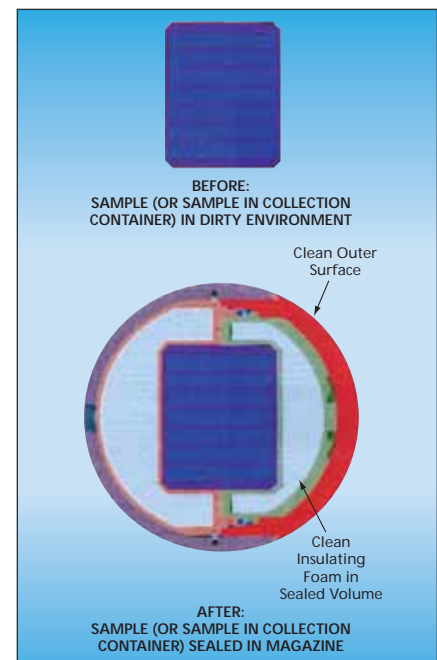

A Sample Would Be Packaged in a magazine with redundant mechanical and brazed seals. Prior to sealing, the surfaces destined to become the outside surface of the magazine would be kept isolated from the dirty sample-collection environment. As an extra precaution, after sealing, the outside surface could be sterilized by ignition of pyrotechnic paint.

biological contamination, it could be feasible to substitute a lower-melting-temperature solder for the brazing material.

The method now proposed goes beyond what was reported previously by providing for container-design modifications and additional process steps to ensure cleanliness and delivery of a hermetically enclosed dirty sample to a clean environment. Implementation of the proposed method in the original intended Mars-to-Earth application would entail the use of dedicated machinery in a multistep augmented version of the previously reported S³B process that would result in sealing of the sample in a magazine and (see figure) and placement of the magazine in the nose cone of a spacecraft. Modified versions of the machinery and process, without provision for placement in a nose cone, could be devised for terrestrial applications. One feature of the outer-space process that might be useful in some terrestrial applications would be coating the outer surface of the magazine with a pyrotechnic paint, which would be ignited to in-

sure sterilization before releasing the magazine into the clean environment.

The method as now proposed also provides additional options to choose materials and process conditions to suit specific applications. These options include the following:

- The sample container and the lid could be made of a nonmetallic material, in which case a mixture of plastic and metallic particles could serve as an appropriate lower-melting-temperature alternative to a brazing material. The metallic particles would render the mixture amenable to inductive heating, so that the plastic component could be melted to make or break a seal.
- During brazing or during the cool-down after brazing, expansion or contraction, respectively, of the gas inside the sample container could push the brazing material away from the desired braze joint. One way to limit expansion and contraction to a harmlessly low level would be to line the inside of the sample container with a thermally insulating material.

- Instead of trying to limit the aforementioned expansion and contraction, one could fabricate the sample container with a small breathing hole to accommodate the expansion and contraction. The hole would be sealed in a small, localized brazing operation after the main S³B brazing operation.

This work was done by Yoseph Bar-Cohen, Mircea Badescu, Xiaoqi Bao, Stewart Sherrit, and Ayoola Olorunsola of Caltech for NASA's Jet Propulsion Laboratory.

In accordance with Public Law 96-517, the contractor has elected to retain title to this invention. Inquiries concerning rights for its commercial use should be addressed to:

Innovative Technology Assets Management

JPL

Mail Stop 202-233

4800 Oak Grove Drive

Pasadena, CA 91109-8099

E-mail: iaoffice@jpl.nasa.gov

Refer to NPO-45610, volume and number of this NASA Tech Briefs issue, and the page number.



➤ **Converting EOS Data From HDF-EOS to netCDF**

A C-language computer program accepts, as input, a set of scientific data and metadata from an Earth Observing System (EOS) satellite and converts the set from (1) the format in which it was created and delivered to (2) another format for processing and exchange of data on Earth. The first-mentioned format can be either HDF-EOS 2 or HDF-EOS 5 (“HDF” signifies “Hierarchical Data Format”). The second-mentioned format is netCDF (“CDF” signifies “Common Data Format”), which is an open-standard, machine-independent, self-describing format for scientific-data files. In the absence of this or a similar program, incompatibilities among the three file formats can cause loss of metadata upon conversion.

This program preserves as many of the metadata as possible upon conversion. The program opens the input HDF-EOS 2 or HDF-EOS 5 file, queries the components of the file by use of the HDF-EOS 2 and HDF-EOS 5 Compatibility Library (which is described in the immediately following article and provides uniform access to HDF-EOS 2 and HDF-EOS 5 files), and writes the data and metadata components into a netCDF file following the Climate and Forecast (CF) metadata conventions.

This program was written by Richard Ullman of Goddard Space Flight Center; Bob Bane of Global Science & Technology, Inc.; and Jingli Yang of Earth Resources Technology, Inc. Further information is contained in a TSP (see page 1). GSC-15007-1

➤ **HDF-EOS 2 and HDF-EOS 5 Compatibility Library**

The HDF-EOS 2 and HDF-EOS 5 Compatibility Library contains C-language functions that provide uniform access to HDF-EOS 2 and HDF-EOS 5 files through one set of application programming interface (API) calls. (“HDF-EOS 2” and “HDF-EOS 5” are defined in the immediately preceding article.) Without this library, differences between the APIs of HDF-EOS 2 and HDF-EOS 5 would necessitate writing of different programs to cover HDF-EOS 2 and HDF-EOS 5. The API associated with this library is denoted “he25.”

For nearly every HDF-EOS 5 API call, there is a corresponding he25 API call. If a file in question is in the HDF-EOS 5 format, the code reverts to the corresponding HDF-EOS 5 call; if the file is in the HDF-EOS 2 format, the code translates the arguments to HDF-EOS 2 equivalents (if necessary), calls the HDF-EOS 2 call, and retranslates the results back to HDF-EOS 5 (if necessary).

This program was written by Richard Ullman of Goddard Space Flight Center; Bob Bane of Global Science & Technology, Inc.; and Jingli Yang of Earth Resources Technology, Inc. Further information is contained in a TSP (see page 1). GSC-15008-1

➤ **HDF-EOS Web Server**

A shell script has been written as a means of automatically making HDF-EOS-formatted data sets available via the World Wide Web. (“HDF-EOS” and variants thereof are defined in the first of the two immediately preceding articles.) The shell script chains together some software tools developed by the Data Usability Group at Goddard Space Flight Center to perform the following actions:

- Extract metadata in Object Definition Language (ODL) from an HDF-EOS file,
- Convert the metadata from ODL to Extensible Markup Language (XML),
- Reformat the XML metadata into human-readable Hypertext Markup Language (HTML),
- Publish the HTML metadata and the original HDF-EOS file to a Web server and an Open-source Project for a Network Data Access Protocol (OPeNDAP) server computer, and
- Reformat the XML metadata and submit the resulting file to the EOS Clearinghouse, which is a Web-based metadata clearinghouse that facilitates searching for, and exchange of, Earth-Science data.

This program was written by Richard Ullman of Goddard Space Flight Center; Bob Bane of Global Science & Technology, Inc.; and Jingli Yang of Earth Resources Technology, Inc. Further information is contained in a TSP (see page 1). GSC-15011-1

➤ **HDF-EOS 5 Validator**

A computer program partly automates the task of determining whether an HDF-EOS 5 file is valid in that it conforms to

specifications for such characteristics as attribute names, dimensionality of data products, and ranges of legal data values. [“HDF-EOS” and variants thereof are defined in “Converting EOS Data From HDF-EOS to netCDF” (GSC-15007-1), which is the first of several preceding articles in this issue of *NASA Tech Briefs*.] Previously, validity of a file was determined in a tedious and error-prone process in which a person examined human-readable dumps of data-file-format information.

The present software helps a user to encode the specifications for an HDF-EOS 5 file, and then inspects the file for conformity with the specifications: First, the user writes the specifications in Extensible Markup Language (XML) by use of a document type definition (DTD) that is part of the program. Next, the portion of the program (denoted the validator) that performs the inspection is executed, using, as inputs, the specifications in XML and the HDF-EOS 5 file to be validated. Finally, the user examines the output of the validator.

This program was written by Richard Ullman of Goddard Space Flight Center; Bob Bane of Global Science & Technology, Inc.; and Jingli Yang of Earth Resources Technology, Inc. Further information is contained in a TSP (see page 1). GSC-15015-1

➤ **XML DTD and Schemas for HDF-EOS**

An Extensible Markup Language (XML) document type definition (DTD) standard for the structure and contents of HDF-EOS files and their contents, and an equivalent standard in the form of schemas, have been developed. (“HDF-EOS” and variants thereof are defined in the first two of four related articles immediately preceding this one.) More specifically, this standard describes the structure and contents of a single HDF-EOS 5 file based on the HDF-EOS model as published in Volumes 1 and 2 of the HDF-EOS Library Users Guide. The DTD and schemas are easy-to-use representations of a complex file format, enabling display of data in multiple ways.

By means of HDF5 XML software tools from the National Center for Supercomputing Applications, the user can transform HDF5 files into XML files or vice versa. Inasmuch as HDF-EOS 5 files are HDF5 files, the same software tools can

be used to (1) transform any HDF-EOS 5 file into an XML file or vice versa or (2) convert, into an HDF-EOS 5 file, any XML file that conforms to the DTD or schemas.

This program was written by Richard Ullman of Goddard Space Flight Center; Jingli Yang of Earth Resources Technology, Inc.; and Muhammad Rabi of Global Science & Technology, Inc. Further information is contained in a TSP (see page 1). GSC-15016-1

Converting From XML to HDF-EOS

A computer program recreates an HDF-EOS file from an Extensible Markup Language (XML) representation of the contents of that file. (“HDF-EOS” and variants thereof are defined in the first of five related articles that immediately precede this article.) This program is one of two programs written to enable testing of the schemas described in the immediately preceding article to determine whether the schemas capture all details of HDF-EOS files. (The other program converts an HDF-EOS file into an XML file.) This program uses a General Purpose Language (GPL) parser called “expat” to parse XML and control extraction of data from an input XML file.

This program was written by Richard Ullman of Goddard Space Flight Center; Bob Bane of Global Science & Technology, Inc.; and Jingli Yang of Earth Resources Technology, Inc. Further information is contained in a TSP (see page 1). GSC-15017-1

Simulating Attitudes and Trajectories of Multiple Spacecraft

A computer program called “42” simulates the attitudes and trajectories of multiple spacecraft flying in formation anywhere in the Solar System. The rotational dynamics are represented by high-fidelity models of spacecraft, each comprising as many as three connected rigid bodies and containing as many as four flywheel mechanisms for storing angular momentum for controlling attitude. The translational dynamics are represented partly by Encke’s method of orbit perturbation, which enables the use of a reference trajectory shared by multiple spacecraft and, in so doing, enables separation of gigameter-scale trajectory features from nanometer-scale formation adjustments to preserve the numerical accuracy needed for simulating precise multi-spacecraft formations.

Other models include planetary

ephemerides and models for solar-radiation pressure, effects of the terrestrial magnetic field, effects of the terrestrial atmosphere, and non-spherical components of the geopotential. The program provides a graphical display that facilitates visualization of individual behaviors of, and interactions among, the spacecraft in a formation. Models of spacecraft sensors, control laws, and control-actuator dynamics are included; these models can be customized (this can include linking to real flight software) to enable high-fidelity simulation.

This program was written by Eric Stoneking of Goddard Space Flight Center. Further information is contained in a TSP (see page 1). GSC-14817-1

Specialized Color Function for Display of Signed Data

This Mathematica script defines a color function to be used with Mathematica’s plotting modules for differentiating data attaining both positive and negative values. Positive values are shown as shades of blue, and negative values are shown in red. The intensity of the color reflects the absolute value of the data value.

The quantization is the same for both positive and negative values, so that comparable intensities accurately reflect comparable data magnitudes. Customization is done through several software switches. The number of color bins to be used is selected by “nshades.” “Linear” is set to 1 for a linear mapping of data magnitudes to color, and set to 0 for nonlinear mapping. The nonlinear choice uses a cube root data-mapping to encompass a large data range while accentuating the smaller data values. This innovation allows nonlinear stretching of data to enhance visualization at the low end of the scale while still viewing the entire data range (the data range set by the user).

This work was done by Virginia Kalb of Goddard Space Flight Center. For further information, contact the Goddard Innovative Partnerships Office at (301) 286-5810. GSC-15128-1

Delivering Alert Messages to Members of a Work Force

Global Alert Resolution Network (GARNET) is a software system for delivering emergency alerts as well as less-urgent messages to members of the Goddard Space Flight Center work force via an intranet or the Internet, and can be adapted to similar use in other large organizations. Messages can be presented

in visible and audible forms on such diverse terminals as desktop computers, portable alphanumeric pagers, telephones, fire alarms, and closed-circuit television. GARNET includes client components running on workers’ desktop computers, and server components running on redundant computers behind firewalls.

An authorized user enters a message, selecting its degree of urgency and the group of intended recipients. The message is then disseminated to the recipients along with a link to more-detailed information. GARNET can deliver a message by server push (in which it interrupts a user’s work to present the message on the user’s computer or other device) or client pull (in which a user’s computer polls the server periodically). GARNET determines whether a given client receives alerts via client pull or server push when the client logs onto the server. To reduce network traffic, GARNET gives preference to server push.

This program was written by Julia Loftis and Stephanie Nickens of Goddard Space Flight Center and Melissa Pell and Vince Pell of Science Systems and Applications, Inc. Further information is contained in a TSP (see page 1). GSC-14927-1

Delivering Images for Mars Rover Science Planning

A methodology has been developed for delivering, via the Internet, images transmitted to Earth from cameras on the Mars Explorer Rovers, the Phoenix Mars Lander, the Mars Science Laboratory, and the Mars Reconnaissance Orbiter spacecraft. The images in question are used by geographically dispersed scientists and engineers in planning Rover scientific activities and Rover maneuvers pertinent thereto.

The methodology, which effects a compromise among levels of image detail, fidelity, and delivery speed, combines image compression with an adaptive level-of-detail image-delivery strategy that scales very well up to larger images that can include mosaic and high-resolution orbital images. In this methodology, images are tiled at multiple levels of detail. An image-browsing application program makes requests for tiles instead of entire images, thereby greatly accelerating delivery of images. At one extreme, a tile could contain a low-resolution representation of what originated as a large mosaic or high-resolution image. At the other extreme, a

tile could contain a high-resolution representation of a small portion of a large image. For either extreme or for an intermediate case, rather than waste time transmitting data that are not used, only tiles that fill users' screens are delivered.

This work was done by Mark W. Powell, Thomas M. Crockett, Joseph C. Joswig, Jeffrey S. Norris, Khawaja S. Shams, Jason M. Fox, and Recaredo Jay Torres of Caltech for NASA's Jet Propulsion Laboratory.

The software used in this innovation is available for commercial licensing. Please contact Karina Edmonds of the California Institute of Technology at (626) 395-2322. Refer to NPO-45671.



❖ Oxide Fiber Cathode Materials for Rechargeable Lithium Cells

Lyndon B. Johnson Space Center, Houston, Texas

LiCoO₂ and LiNiO₂ fibers have been investigated as alternatives to LiCoO₂ and LiNiO₂ powders used as lithium-intercalation compounds in cathodes of rechargeable lithium-ion electrochemical cells. In making such a cathode, LiCoO₂ or LiNiO₂ powder is mixed with a binder [e.g., poly(vinylidene fluoride)] and an electrically conductive additive (usually carbon) and the mixture is pressed to form a disk. The binder and conductive additive contribute weight and volume, reducing the specific energy and energy density, respectively.

In contrast, LiCoO₂ or LiNiO₂ fibers can be pressed and sintered to form a

cathode, without need for a binder or a conductive additive. The inter-grain contacts of the fibers are stronger and have fewer defects than do those of powder particles. These characteristics translate to increased flexibility and greater resilience on cycling and, consequently, to reduced loss of capacity from cycle to cycle. Moreover, in comparison with a powder-based cathode, a fiber-based cathode is expected to exhibit significantly greater ionic and electronic conduction along the axes of the fibers. Results of preliminary charge/discharge-cycling tests suggest that energy densities of LiCoO₂- and

LiNiO₂-fiber cathodes are approximately double those of the corresponding powder-based cathodes.

This work was done by Catherine E. Rice and Mark F. Welker of TPL, Inc., for Johnson Space Center.

In accordance with Public Law 96-517, the contractor has elected to retain title to this invention. Inquiries concerning rights for its commercial use should be addressed to:

TPL, Inc.

*3921 Academy Parkway North, NE
Albuquerque, NM 87109-4416*

Refer to MSC-22892-1, volume and number of this NASA Tech Briefs issue, and the page number.

❖ Electrocatalytic Reduction of Carbon Dioxide to Methane

Lyndon B. Johnson Space Center, Houston, Texas

A room-temperature electrocatalytic process that effects the overall chemical reaction $\text{CO}_2 + 2\text{H}_2\text{O} \rightarrow \text{CH}_4 + 2\text{O}_2$ has been investigated as a means of removing carbon dioxide from air and restoring oxygen to the air. The process was originally intended for use in a spacecraft life-support system, in which the methane would be vented to outer space. The process may also have potential utility in terrestrial applications in which either or both of the

methane and oxygen produced might be utilized or vented to the atmosphere.

A typical cell used to implement the process includes a polymer solid-electrolyte membrane, onto which are deposited cathode and anode films. The cathode film is catalytic for electrolytic reduction of CO₂ at low overpotential. The anode film is typically made of platinum. When CO₂ is circulated past the cathode, water is circulated past the

anode, and a suitable potential is applied, the anode half-cell reaction is $4\text{H}_2\text{O} \rightarrow 2\text{O}_2 + 8\text{H}^+ + 8\text{e}^-$. The H⁺ ions travel through the membrane to the cathode, where they participate in the half-cell reaction $\text{CO}_2 + 8\text{H}^+ + 8\text{e}^- \rightarrow \text{CH}_4 + 2\text{H}_2\text{O}$.

This work was done by Anthony F. Sammells and Ella F. Spiegel of Eltron Research, Inc. for Johnson Space Center. Further information is contained in a TSP (see page 1). MSC-23097-1

❖ Heterogeneous Superconducting Low-Noise Sensing Coils

Electrically superconductive outer layers are supported by highly thermally conductive skeletons.

NASA's Jet Propulsion Laboratory, Pasadena, California

A heterogeneous material construction has been devised for sensing coils of superconducting quantum interference device (SQUID) magnetometers that are subject to a combination of requirements peculiar to some advanced applications, notably including low-field magnetic resonance imaging for medical diagnosis. The requirements in question are the following:

- The sensing coils must be large enough (in some cases having dimensions of as much as tens of centimeters) to afford adequate sensitivity;
- The sensing coils must be made electrically superconductive to eliminate Johnson noise (thermally induced noise proportional to electrical resistance); and
- Although the sensing coils must be cooled to below their superconduct-

ing-transition temperatures with sufficient cooling power to overcome moderate ambient radiative heat leakage, they must not be immersed in cryogenic liquid baths.

For a given superconducting sensing coil, this combination of requirements can be satisfied by providing a sufficiently thermally conductive link between the coil and a cold source. How-

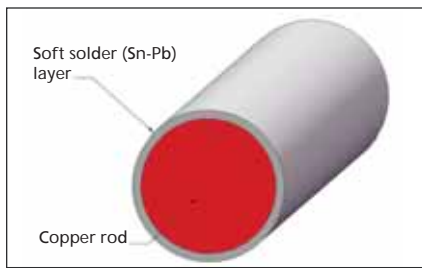

A Solder-Covered Copper Rod or Wire affords the benefit of high thermal conductivity of the copper and, when sufficiently cold, electrical superconductivity of the solder.

ever, the superconducting coil material is not suitable as such a link because electrically superconductive materials are typically poor thermal conductors.

The heterogeneous material construction makes it possible to solve both the electrical- and thermal-conductivity problems. The basic idea is to construct the coil as a skeleton made of a highly thermally conductive material (typically, annealed copper), then coat the skeleton with an electrically superconductive alloy (typically, a lead-tin solder) [see figure]. In operation, the copper skeleton provides the required thermally conductive connection to the cold source, while the electrically superconductive coating material shields against Johnson noise that originates in the copper skeleton.

This work was done by Inseob Hahn, Konstantin I. Penanen, and Byeong Ho Eom of

Caltech for NASA's Jet Propulsion Laboratory. Further information is contained in a TSP (see page 1).

In accordance with Public Law 96-517, the contractor has elected to retain title to this invention. Inquiries concerning rights for its commercial use should be addressed to:

*Innovative Technology Assets Management
JPL*

Mail Stop 202-233

4800 Oak Grove Drive

Pasadena, CA 91109-8099

E-mail: iaoffice@jpl.nasa.gov

Refer to NPO-45929, volume and number of this NASA Tech Briefs issue, and the page number.

Progress Toward Making Epoxy/Carbon-Nanotube Composites

Lyndon B. Johnson Space Center, Houston, Texas

A modicum of progress has been made in an effort to exploit single-walled carbon nanotubes as fibers in epoxy-matrix/fiber composite materials. Two main obstacles to such use of carbon nanotubes are the following: (1) bare nanotubes are not soluble in epoxy resins and so they tend to agglomerate instead of becoming dispersed as desired; and (2) because of lack of affinity between nanotubes and epoxy matrices, there is insufficient transfer of mechanical loads between the nanotubes and the matrices.

Part of the effort reported here was oriented toward (1) functionalization of single-walled carbon nanotubes with methyl methacrylate (MMA) to increase their dispersability in epoxy resins and increase transfer of mechanical loads and (2) ultrasonic dispersion of the functionalized nanotubes in tetrahydrofuran, which was used as an auxiliary solvent to aid in dispersing the functionalized nanotubes into an epoxy resin. In another part of this effort, poly(styrene sulfonic acid) was used as the dispersant

and water as the auxiliary solvent. In one experiment, the strength of composite of epoxy with MMA-functionalized-nanotubes was found to be 29 percent greater than that of a similar composite of epoxy with the same proportion of untreated nanotubes.

This work was done by Thomas Tiano, Margaret Roylance, and John Gassner of Foster-Miller, Inc. and William Kyle (consultant) for Johnson Space Center. Further information is contained in a TSP (see page 1). MSC-23278-1

Predicting Properties of Unidirectional-Nanofiber Composites

John H. Glenn Research Center, Cleveland, Ohio

A theory for predicting mechanical, thermal, electrical, and other properties of unidirectional-nanofiber/matrix composite materials is based on the prior theory of micromechanics of composite materials. In the development of the present theory, the prior theory of micromechanics was extended, through progressive substructuring, to the level of detail of a nanoscale slice of a nanofiber. All the governing equations were then formulated at this level.

The substructuring and the equations have been programmed in the

ICAN/JAVA computer code, which was reported in "ICAN/JAVA: Integrated Composite Analyzer Recoded in Java" (LEW-17247), *NASA Tech Briefs*, Vol. 26, No. 12 (December 2002), page 36. In a demonstration, the theory as embodied in the computer code was applied to a graphite-nanofiber/epoxy laminate and used to predict 25 properties. Most of the properties were found to be distributed along the through-the-thickness direction. Matrix-dependent properties were found to have bimodal through-the-thickness distributions with discon-

tinuous changes from mode to mode.

This work was done by Christos C. Chamis, Louis M. Handler, and Jane Manderscheid of Glenn Research Center. Further information is contained in a TSP (see page 1).

Inquiries concerning rights for the commercial use of this invention should be addressed to NASA Glenn Research Center, Innovative Partnerships Office, Attn: Steve Fedor, Mail Stop 4-8, 21000 Brookpark Road, Cleveland, Ohio 44135. Refer to LEW-18366-1.



⚙️ Deployable Crew Quarters

Lyndon B. Johnson Space Center, Houston, Texas

The deployable crew quarters (DCQ) have been designed for the International Space Station (ISS). Each DCQ would be a relatively inexpensive, deployable box-like structure that is designed to fit in a rack bay. It is to be occupied by one crewmember to provide privacy and sleeping functions for the crew. A DCQ comprises mostly hard panels, made of a lightweight honeycomb or matrix/fiber material, attached to each other by cloth hinges. Both faces of each panel are covered with a layer of Nomex cloth and noise-suppression material to provide noise isolation from ISS.

On Earth, the unit is folded flat and attached to a rigid pallet for transport to the ISS. On the ISS, crewmembers un-

fold the unit and install it in place, attaching it to ISS structural members by use of soft cords (which also help to isolate noise and vibration). A few hard pieces of equipment (principally, a ventilator and a smoke detector) are shipped separately and installed in the DCQ unit by use of a system of holes, slots, and quarter-turn fasteners.

Full-scale tests showed that the time required to install a DCQ unit amounts to tens of minutes. The basic DCQ design could be adapted to terrestrial applications to satisfy requirements for rapid deployable emergency shelters that would be lightweight, portable, and quickly erected. The Temporary Early Sleep Station (TeSS) currently on-orbit is a spin-off of the DCQ.

This work was done by William C. Schneider, Kriss J. Kennedy, and Nathan R. Moore of Johnson Space Center and James Mabie of Muniz Engineering. Further information is contained in a TSP (see page 1).

In accordance with Public Law 96-517, the contractor has elected to retain title to this invention. Inquiries concerning rights for its commercial use should be addressed to:

*MEI Technologies, Corporate Headquarters
2525 Bay Area Blvd., Suite 300*

Houston, Texas 77058

Phone No.: (281) 283-6200 / (888) 895-3014

Fax No.: (281) 283-6170

E-mail: meinfo@meitechinc.com

Refer to MSC-23132-1, volume and number of this NASA Tech Briefs issue, and the page number.

⚙️ Nonventing, Regenerable, Lightweight Heat Absorber

Lyndon B. Johnson Space Center, Houston, Texas

A lightweight, regenerable heat absorber (RHA), developed for rejecting metabolic heat from a space suit, may also be useful on Earth for short-term cooling of heavy protective garments. Unlike prior space-suit-cooling systems, a system that includes this RHA does not vent water. The closed system contains water reservoirs, tubes through which water is circulated to absorb heat, an evaporator, and an absorber/radiator. The radiator includes a solution of LiCl contained in a porous material in titanium tubes.

The evaporator cools water that circulates through a liquid-cooled gar-

ment. Water vapor produced in the evaporator enters the radiator tubes where it is absorbed into the LiCl solution, releasing heat. Much of the heat of absorption is rejected to the environment via the radiator. After use, the RHA is regenerated by heating it to a temperature of 100 °C for about 2 hours to drive the absorbed water back to the evaporator. A system including a prototype of the RHA was found to be capable of maintaining a temperature of 20 °C while removing heat at a rate of 200 W for 6 hours.

This work was done by Michael G. Izenson and Weibo Chen of Creare Inc. for Johnson

Space Center. Further information is contained in a TSP (see page 1).

In accordance with Public Law 96-517, the contractor has elected to retain title to this invention. Inquiries concerning rights for its commercial use should be addressed to:

Creare Inc.

P.O. Box 71

16 Great Hollow Road

Hanover, NH 03755

Phone No. (603) 643-3800

Fax No.: (603) 643-4657

URL: www.creare.com

Refer to MSC-23914-1, volume and number of this NASA Tech Briefs issue, and the page number.

⚙️ Miniature High-Force, Long-Stroke SMA Linear Actuators

Stroke forces, stroke lengths, cycle speeds, and structural strengths are increased.

John H. Glenn Research Center, Cleveland, Ohio

Improved long-stroke shape-memory alloy (SMA) linear actuators are being developed to exert significantly higher forces and operate at higher activation

temperatures than do prior SMA actuators. In these actuators, long linear strokes are achieved through the principle of displacement multiplication, according to

which there are multiple stages, each intermediate stage being connected by straight SMA wire segments to the next stage so that relative motions of stages are

additive toward the final stage, which is the output stage.

Prior SMA actuators typically include polymer housings or shells, steel or aluminum stages, and polymer pads between successive stages of displacement-multiplication assemblies. Typical output forces of prior SMA actuators range from 10 to 20 N, and typical strokes range from 0.5 to 1.5 cm. An important disadvantage of prior SMA wire actuators is relatively low cycle speed, which is related to actuation temperature as follows: The SMA wires in prior SMA actuators are typically made of a durable nickel/titanium alloy that has a shape-memory activation temperature of 80 °C. An SMA wire can be heated quickly from below to above its activation temperature to obtain a stroke in one direction, but must then be allowed to cool to somewhat below its activation temperature (typically, to ≤ 60 °C in the case of an activation temperature of 80 °C) to obtain a stroke in the opposite direction (return stroke). At typical ambient temperatures, cooling times are of the order of several seconds. Cooling times thus limit cycle speeds. Wires made of SMA alloys having significantly higher activation temperatures [denoted ultra-high-temperature

(UHT) SMA alloys] cool to the required lower return-stroke temperatures more rapidly, making it possible to increase cycle speeds.

The present development is motivated by a need, in some applications (especially aeronautical and space-flight applications) for SMA actuators that exert higher forces, operate at greater cycle speeds, and have stronger housings that can withstand greater externally applied forces and impacts. The main novel features of the improved SMA actuators are the following:

- The ends of the wires are anchored in compact crimps made from short steel tubes. Each wire end is inserted in a tube, the tube is flattened between planar jaws to make the tube grip the wire, the tube is compressed to a slight U-cross-section deformation to strengthen the grip, then the crimp is welded onto one of the actuator stages. The pull strength of a typical crimp is about 125 N — comparable to the strength of the SMA wire and greater than the typical pull strengths of wire-end anchors in prior SMA actuators. Greater pull strength is one of the keys to achievement of higher actuation force.

- For greater strength and resistance to impacts, housings are milled from aluminum instead of being made from polymers. Each housing is made from two pieces in a clamshell configuration. The pieces are anodized to reduce sliding friction.
- Stages are made stronger (to bear greater compression loads without excessive flexing) by making them from steel sheets thicker than those used in prior SMA actuators. The stages contain recessed pockets to accommodate the crimps. Recessing the pockets helps to keep overall dimensions as small as possible.
- UHT SMA wires are used to satisfy the higher-speed/higher-temperature requirement.

This work was done by Mark A. Cummin, William Donakowski, and Howard Cohen of MIGA Motor Co. for Glenn Research Center. Further information is contained in a TSP (see page 1).

Inquiries concerning rights for the commercial use of this invention should be addressed to NASA Glenn Research Center, Innovative Partnerships Office, Attn: Steve Fedor, Mail Stop 4-8, 21000 Brookpark Road, Cleveland, Ohio 44135. Refer to LEW-18267-1.

⚙️ “Bootstrap” Configuration for Multistage Pulse-Tube Coolers

Lyndon B. Johnson Space Center, Houston, Texas

A “bootstrap” configuration has been proposed for multistage pulse-tube coolers that, for instance, provide final-stage cooling to temperatures as low as 20 K. The bootstrap configuration supplants the conventional configuration, in which customarily the warm heat exchangers of all stages reject heat at ambient temperature. In the bootstrap con-

figuration, the warm heat exchanger, the inertance tube, and the reservoir of each stage would be thermally anchored to the cold heat exchanger of the next warmer stage. The bootstrapped configuration is superior to the conventional setup, in some cases increasing the 20 K cooler’s coefficient of performance two-fold over that of an otherwise equivalent

conventional layout. The increased efficiency could translate into less power consumption, less cooler mass, and/or lower cost for a given amount of cooling.

This work was done by Ali Kashani and Ben Helvensteijn of Atlas Scientific for Johnson Space Center. Further information is contained in a TSP (see page 1).

MSC-23500-1

⚙️ Reducing Liquid Loss During Ullage Venting in Microgravity

Lyndon B. Johnson Space Center, Houston, Texas

A centripetal-force-based liquid/gas separator has been proposed as a means of reducing the loss of liquid during venting of the ullage of a tank in microgravity as a new supply of liquid is pumped into the tank. Centripetal-force-based liquid/gas separators are used on Earth, where mechanical drives (e.g., pumps and spinners) are used to

impart flow speeds sufficient to generate centripetal forces large enough to effect separation of liquids from gases.

For the proposed application, the separator would be designed so that there would be no need for such a pump because the tank-pressure-induced outflow speed during venting of the ullage would be sufficient for centripetal separa-

tion. A relatively small pump would be used, not for separation, but for returning the liquid recovered by the separator to the tank.

This work was done by Bich Nguyen and Lauren Nguyen of The Boeing Co. for Johnson Space Center. For further information, contact the JSC Innovation Partnerships Office at (281) 483-3809. MSC-23230-1



Books & Reports

Ka-Band Transponder for Deep-Space Radio Science

A one-page document describes a Ka-band transponder being developed for use in deep-space radio science. The transponder receives in the Deep Space Network (DSN) uplink frequency band of 34.2 to 34.7 GHz, transmits in the 31.8- to 32.3 GHz DSN downlink band, and performs regenerative ranging on a DSN standard 4-MHz ranging tone subcarrier phase-modulated onto the uplink carrier signal. A primary consideration in this development is reduction in size, relative to other such transponders.

The transponder design is all-analog, chosen to minimize not only the size but also the number of parts and the design time and, thus, the cost. The receiver features two stages of frequency down-conversion. The receiver locks onto the uplink carrier signal. The exciter signal for the transmitter is derived from the same source as that used to generate the first-stage local-oscillator signal. The ranging-tone subcarrier is down-converted along with the carrier to the second intermediate frequency, where the 4-MHz tone is demodulated from the composite signal and fed into a ranging-tone-tracking loop, which regenerates the tone. The regenerated tone is linearly phase-modulated onto the downlink carrier.

This work was done by Matthew S. Dennis, Narayan R. Mysoor, William M. Folkner, Ricardo Mendoza, and Jaikrishna Venkatesan of Caltech for NASA's Jet Propulsion Laboratory. Further information is contained in a TSP (see page 1). NPO-45598

Replication of Space-Shuttle Computers in FPGAs and ASICs

A document discusses the replication of the functionality of the onboard space-shuttle general-purpose computers (GPCs) in field-programmable gate

arrays (FPGAs) and application-specific integrated circuits (ASICs). The purpose of the replication effort is to enable utilization of proven space-shuttle flight software and software-development facilities to the extent possible during development of software for flight computers for a new generation of launch vehicles derived from the space shuttles. The replication involves specifying the instruction set of the central processing unit and the input/output processor (IOP) of the space-shuttle GPC in a hardware description language (HDL).

The HDL is synthesized to form a "core" processor in an FPGA or, less preferably, in an ASIC. The core processor can be used to create a flight-control card to be inserted into a new avionics computer. The IOP of the GPC as implemented in the core processor could be designed to support data-bus protocols other than that of a multiplexer interface adapter (MIA) used in the space shuttle. Hence, a computer containing the core processor could be tailored to communicate via the space-shuttle GPC bus and/or one or more other buses.

This work was done by Roscoe C. Ferguson of United Space Alliance for Johnson Space Center. Further information is contained in a TSP (see page 1). MSC-24141-1

Demisable Reaction-Wheel Assembly

A document discusses the concept of a demisable motor-drive-and-flywheel assembly [reaction-wheel assembly (RWA)] used in controlling the attitude of a spacecraft. "Demisable" as used here does not have its traditional legal meaning; instead, it signifies susceptible to melting, vaporizing, and/or otherwise disintegrating during re-entry of the spacecraft into the atmosphere of the Earth so as not to pose a hazard to any-

one or anything on the ground. Prior RWAs include parts made of metals (e.g., iron, steel, and titanium) that melt at high temperatures and include structures of generally closed character that shield some parts (e.g., magnets) against re-entry heating.

In a demisable RWA, the flywheel would be made of aluminum, which melts at a lower temperature. The flywheel web would not be a solid disk but would have a more open, nearly-spoke-like structure so that it would disintegrate more rapidly; hence, the flywheel rim would separate more rapidly so that parts shielded by the rim would be exposed sooner to re-entry heating. In addition, clearances between the flywheel and other components would be made greater, imparting a more open character and thus increasing the exposure of those components.

This work was done by Russell Roder and Eliezer Ahronovich of Goddard Space Flight Center and Milton C. Davis III of Purdue University. Further information is contained in a TSP (see page 1). GSC-14845-1

Spatial and Temporal Low-Dimensional Models for Fluid Flow

A document discusses work that obtains a low-dimensional model that captures both temporal and spatial flow by constructing spatial and temporal four-mode models for two classic flow problems. The models are based on the proper orthogonal decomposition at two reference Reynolds numbers. Model predictions are made at an intermediate Reynolds number and compared with direct numerical simulation results at the new Reynolds number.

This work was done by Virginia Kalb of Goddard Space Flight Center. Further information is contained in a TSP (see page 1). GSC-15130-1



Advanced Land Imager Assessment System

An integrated system provides radiometric and geometric calibration and validation data processing for a multispectral pushbroom instrument.

Goddard Space Flight Center, Greenbelt, Maryland

The Advanced Land Imager Assessment System (ALIAS) supports radiometric and geometric image processing for the Advanced Land Imager (ALI) instrument onboard NASA's Earth Observing-1 (EO-1) satellite. ALIAS consists of two processing subsystems for radiometric and geometric processing of the ALI's multispectral imagery. The radiometric processing subsystem characterizes and corrects, where possible, radiometric qualities including: coherent, impulse; and random noise; signal-to-noise ratios (SNRs); detector operability; gain; bias; saturation levels; striping and banding; and the stability of detector performance.

The geometric processing subsystem and analysis capabilities support sensor alignment calibrations, sensor chip assembly (SCA)-to-SCA alignments and band-to-band alignment; and perform geodetic accuracy assessments, modulation transfer function (MTF) characterizations, and image-to-image characterizations. ALIAS also characterizes and corrects band-to-band registration, and performs systematic precision and terrain correction of ALI images. This system can geometrically correct, and automatically mosaic, the SCA image strips into a seamless, map-projected image.

This system provides a large database,

which enables bulk trending for all ALI image data and significant instrument telemetry. Bulk trending consists of two functions: Housekeeping Processing and Bulk Radiometric Processing. The Housekeeping function pulls telemetry and temperature information from the instrument housekeeping files and writes this information to a database for trending. The Bulk Radiometric Processing function writes statistical information from the dark data acquired before and after the Earth imagery and the lamp data to the database for trending. This allows for multi-scene statistical analyses.

An important aspect of this is the partitioning and indexing of data within the database, which enables efficient storage and retrieval of data as well as extremely rapid calibration assessments. The ALIAS team processed the entire ALI archive (over 20,000 scenes) and populated this trending database, approaching one terabyte in size. This database has opened doors for long-term trending, data analyses, and algorithm development not previously possible with the Landsat 7 Image Assessment System (IAS). One area where this bulk trending database appears particularly useful is in the normalization of the detector's

responses within a band, so called flat-fielding. On the assumption that, over a period of several months to a whole mission, all detectors in a band see statistically the same distribution of the Earth radiance, these statistics can be used to match the detector's responses.

ALIAS is built upon previous software used in the Landsat 7 IAS, and by the ALI Science Validation Team (SVT). This innovation takes advantage of open source software, in that it references open source external libraries. This means no software licenses are required. However, no open source code is integrated directly in the ALIAS software.

*ALIAS was a joint effort between NASA and the United States Geological Survey (USGS). The work was done by Tim Beckmann, Gyanesh Chander, Mike Choate, Jon Christopherson, Doug Hollaren, Ron Morfitt, Jim Nelson, Shar Nelson, and James Storey of SAIC@USGS/Earth Resources Observation and Science (EROS); Dennis Helder and Tim Ruggles of South Dakota State University; Ed Kaita, Raviv Levy, and Lawrence Ong of SSAI@NASA/Goddard Space Flight Center(GSFC); and Brian Markham and Robert Schweiss of Goddard Space Flight Center. Further information is contained in a TSP (see page 1).
GSC-15185-1*



Range Imaging Without Moving Parts

Potential applications include proximity detection, robotic vision, and terrain mapping.

Goddard Space Flight Center, Greenbelt, Maryland

Range-imaging instruments of a type now under development are intended to generate the equivalent of three-dimensional images from measurements of the round-trip times of flight of laser pulses along known directions. These instruments could also provide information on characteristics of targets, including roughnesses and reflectivities of surfaces and optical densities of such semi-solid objects as trees and clouds. Unlike in prior range-imaging instruments based on times of flight along known directions, there would be no moving parts; aiming of the laser beams along the known directions would not be accomplished by mechanical scanning of mirrors, prisms, or other optical components. Instead, aiming would be accomplished by using solid-state devices to switch input and output beams along different fiber-optic paths. Because of the lack of moving parts, these instruments could be extraordinarily reliable, rugged, and long-lasting.

An instrument of this type would include an optical transmitter that would send out a laser pulse along a chosen direction to a target. An optical receiver co-aligned with the transmitter would measure the temporally varying intensity of

laser light reflected from the target to determine the distance and surface characteristics of the target.

The transmitter would be a combination of devices for generating precise directional laser illumination. It would include a pulsed laser, the output of which would be coupled into a fiber-optic cable with a fan-out and solid-state optical switches that would enable switching of the laser beam onto one or more optical fibers terminated at known locations in an array on a face at the focal plane of a telescope. The array would be imaged by the telescope onto the target space.

The receiver optical system could share the aforementioned telescope with the transmitter or could include a separate telescope aimed in the same direction as that of the transmitting telescope. In either case, light reflected from the target would be focused by the receiver optical system onto an array of optical fibers matching the array in the transmitter. These optical fibers would couple the received light to one or more photodetector(s). Optionally, the receiver could include solid-state optical switches for choosing which optical fiber(s) would couple light to the photodetector(s).

This instrument architecture is flexible and can be optimized for a wide variety of applications and levels of performance. For example, it is scalable to any number of pixels and pixel resolutions and is compatible with a variety of ranging and photodetection methodologies, including, for example, ranging by use of modulated (including pulsed and encoded) light signals. The use of fixed arrays of optical fibers to generate controlled illumination patterns would eliminate the mechanical complexity and much of the bulk of optomechanical scanning assemblies. Furthermore, digital control of the selection of the fiber-optic pathways for the transmitted beams could afford capabilities not seen in previous three-dimensional range-imaging systems. Instruments of this type could be specialized for use as, for example, proximity detectors, three-dimensional robotic vision systems, airborne terrain-mapping systems, and inspection systems.

This work was done by J. Bryan Blair, V. Stanley Scott III, and Luis Ramos-Izquierdo of Goddard Space Flight Center. Further information is contained in a TSP (see page 1). GSC-15184-1

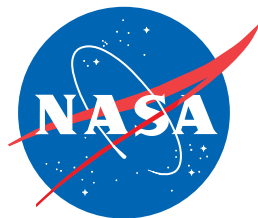

National Aeronautics and
Space Administration