

NASA/TM—2008-215258



Data Optical Networking Architecture Using Wavelength-Division Multiplexing Method for Optical Sensors

Hung D. Nguyen
Glenn Research Center, Cleveland, Ohio

NASA STI Program . . . in Profile

Since its founding, NASA has been dedicated to the advancement of aeronautics and space science. The NASA Scientific and Technical Information (STI) program plays a key part in helping NASA maintain this important role.

The NASA STI Program operates under the auspices of the Agency Chief Information Officer. It collects, organizes, provides for archiving, and disseminates NASA's STI. The NASA STI program provides access to the NASA Aeronautics and Space Database and its public interface, the NASA Technical Reports Server, thus providing one of the largest collections of aeronautical and space science STI in the world. Results are published in both non-NASA channels and by NASA in the NASA STI Report Series, which includes the following report types:

- **TECHNICAL PUBLICATION.** Reports of completed research or a major significant phase of research that present the results of NASA programs and include extensive data or theoretical analysis. Includes compilations of significant scientific and technical data and information deemed to be of continuing reference value. NASA counterpart of peer-reviewed formal professional papers but has less stringent limitations on manuscript length and extent of graphic presentations.
- **TECHNICAL MEMORANDUM.** Scientific and technical findings that are preliminary or of specialized interest, e.g., quick release reports, working papers, and bibliographies that contain minimal annotation. Does not contain extensive analysis.
- **CONTRACTOR REPORT.** Scientific and technical findings by NASA-sponsored contractors and grantees.
- **CONFERENCE PUBLICATION.** Collected

papers from scientific and technical conferences, symposia, seminars, or other meetings sponsored or cosponsored by NASA.

- **SPECIAL PUBLICATION.** Scientific, technical, or historical information from NASA programs, projects, and missions, often concerned with subjects having substantial public interest.
- **TECHNICAL TRANSLATION.** English-language translations of foreign scientific and technical material pertinent to NASA's mission.

Specialized services also include creating custom thesauri, building customized databases, organizing and publishing research results.

For more information about the NASA STI program, see the following:

- Access the NASA STI program home page at <http://www.sti.nasa.gov>
- E-mail your question via the Internet to help@sti.nasa.gov
- Fax your question to the NASA STI Help Desk at 301-621-0134
- Telephone the NASA STI Help Desk at 301-621-0390
- Write to:
NASA Center for AeroSpace Information (CASI)
7115 Standard Drive
Hanover, MD 21076-1320

NASA/TM—2008-215258



Data Optical Networking Architecture Using Wavelength-Division Multiplexing Method for Optical Sensors

Hung D. Nguyen
Glenn Research Center, Cleveland, Ohio

National Aeronautics and
Space Administration

Glenn Research Center
Cleveland, Ohio 44135

September 2008

Level of Review: This material has been technically reviewed by technical management.

Available from

NASA Center for Aerospace Information
7115 Standard Drive
Hanover, MD 21076-1320

National Technical Information Service
5285 Port Royal Road
Springfield, VA 22161

Available electronically at <http://gltrs.grc.nasa.gov>

Data Optical Networking Architecture Using Wavelength-Division Multiplexing Method for Optical Sensors

Hung D. Nguyen
National Aeronautics and Space Administration
Glenn Research Center
Cleveland, Ohio 44135

Summary

Recently there has been a growth in the number of fiber optical sensors used for health monitoring in the hostile environment of commercial aircraft. Health monitoring to detect the onset of failure in structural systems from such causes as corrosion, stress corrosion cracking, and fatigue is a critical factor in safety as well in aircraft maintenance costs. This report presents an assessment of an analysis model of optical data networking architectures used for monitoring data signals among these optical sensors. Our model is focused on the design concept of the wavelength-division multiplexing (WDM) method since most of the optical sensors deployed in the aircraft for health monitoring typically operate in a wide spectrum of optical wavelengths from 710 to 1550 nm.

Introduction

Hundreds of miles of electrical wires are installed in commercial planes for controlling and monitoring everything from landing gear, sensing devices, and communication modules to flight-attendant calls. Reducing the amount of insulated copper wiring could reduce the huge liability because it is susceptible to electromagnetic interference (EMI). However, when wiring is not properly maintained, it can cause system failures and fires (ref. 1). Cabled fibers have been used to replace most of the electrical wires on aircraft because cabled fibers are lightweight, have a high bandwidth, and are immune to EMI.

In aeronautic applications, a number of factors makes optical sensors widely acceptable for replacing the current electronic sensors (ref. 2). Their optical intrinsic property is unaffected by radio or microwave interference, and their small size and low weight enable them to be easily adapted to size-constrained locations in the aircraft. They are also tolerant of high temperatures, shocks, and vibrations, and they are not subject to the sparking seen in conventional electronic sensors (ref. 2). In contrast, conventional electrical sensors, such as thermocouples, thermistors, and bimetal types of devices, are susceptible to EMI and therefore require protective shielding and pose a potential fire hazard because of the aforementioned sparking.

Wavelength-Division Multiplexing Optical Networking Model for Data Signal Detection

Fiber-based extrinsic sensors are widely used in aircraft for measuring a variety of parameters because most of these sensors require inexpensive light sources and also rely on simple detection methods that support reducing the cost of implementing an overall networking system. When routing optical sensing signals in aircraft, optical networks employing wavelength-division multiplexing (WDM) are highly desirable. Such systems currently have channel counts of 40 on a 100-GHz grid spacing, and some others have the capability of operating at 80 channels on a 50-GHz grid spacing, which can handle a high volume of optical sensors. The advantage of using WDM optical networks is that they are more adaptable to a wide spectrum of wavelengths (which emerge from different types of optical sensors) as compared with other technologies, such as time-division multiplexing (TDM), frequency-division multiplexing

(FDM), and subcarrier multiplexing (SCM) (ref. 3). Many of these optical sensors can operate in ranges from 710 to 1550 nm.

As a result of the inherent fiber characteristics, a single fiber can route a vast number of wavelengths greater than hundreds of channels using the WDM method. For this reason, the architecture of an optical networking model based on the WDM method is the practical choice for interrogating data signals from optical sensors operating at a variety of wavelengths.

However, a drawback of this method is that several components of the WDM (transceiver, coupler, multiplexer/demultiplexer, and routers) tend to shift away from their carrier wavelengths, particularly in a high-temperature environment.

The shift contributes to the degradation of signal quality. Most components designed for WDM networks are not able to withstand severe avionic environments because many are built only to survive the Telecordia outdoor specifications, requiring operations over broad temperature ranges (refs. 4 to 6).

The challenge of the scenario just described is to extend the temperature ranges and utilize cooling, heating, and packaging technologies that can survive the vibration, shock, and extended temperature cycling in aerospace environments (ref. 5). A discussion of the optical components developed for WDM architecture networks is presented in a later section.

As shown in figure 1, the WDM optical network model for interrogating data signals from numerous optical sensors is based on Bragg grating methods. The small number of sensors shown in the model are just for illustrative purposes. The model consists of a combination of bus and ring topologies, which can accommodate hundreds of sensors (ref. 7). The incorporation of fiber Bragg grating modules allows one to assign each sensor a specific wavelength that is generated from the grating modules. In figure 1, sensor 1 is assigned with wavelength λ_1 , sensor 2 with wavelength λ_2 , and the last sensor with wavelength λ_5 .

The optical bus topology has two separate fibers made of glass material, each consisting of a number of directional couplers for routing wideband optical signals to the locations of the sensors. Employing directional couplers for optical power distribution at each node on the fiber cable contributes to inherently lossy systems. In most cases, it would limit the number of sensors that can be multiplexed in a single network due to power budget requirements, but compensation of such power loss can be easily achieved with optical amplifier modules. Because the maximum distance for a fiber cable is 300 m in aircraft, the power loss caused by the cable does not contribute enough to incorporate optical amplifiers in the networking system. However, an alternative choice for power loss compensation is the replacement of the directional coupler with a fused biconical WDM module for improving the power budget in the topology (ref. 8).

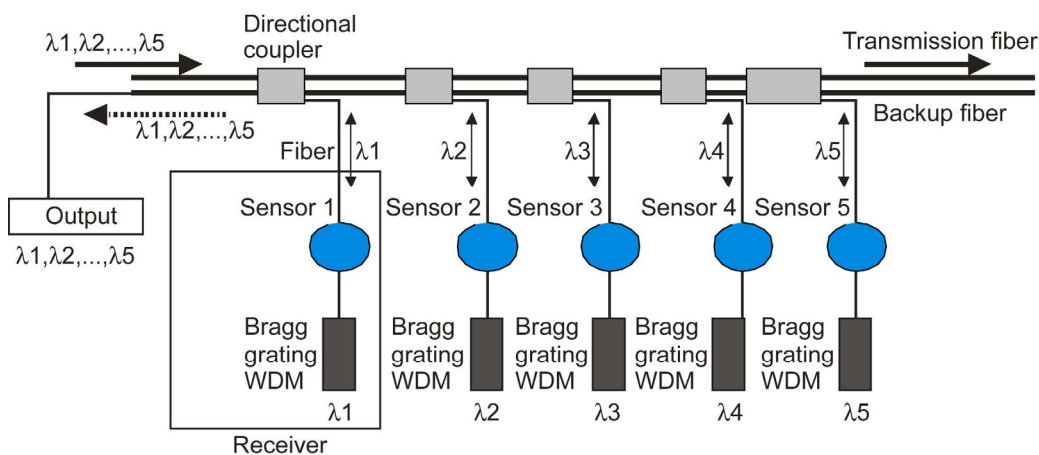

Figure 1.—Wavelength-division multiplexing (WDM) optical networking model for data signal detection from various sensors using Bragg grating method.

Returning to figure 1, there are two fibers implemented in the design configuration. One of the fibers is allocated for data transmission and the other for backup data transmission in case of any failure occurring in the transmission fiber. Such fiber cables require very high thermal and sufficient mechanical properties to withstand the harsh environments with operating temperatures in the range of 55 to 250 °C. Typical performance specifications for cabled fiber in aircraft applications are listed in table I.

TABLE I.—CABLED FIBER REQUIREMENT SPECIFICATIONS

Parameter	Requirement specification
Dimension, μm	50/125, 100/140
Coating type	Polyimide, fluropolymer
Minimum bend diameter, mm	50
Minimum tensile strength at 200 N, percent strain	<0.3
Flammability	DOD-STD-1678
Solvent resistance	JP-grade fuels
Operating temperature	-40 to 85 °C

The number of sensors is equal to the number of optical wavelengths launched into the fiber. A single-mode fiber is preferred for carrying the input signal from the laser source to each sensor. These wavelengths are tapped off from the directional coupler and then are modulated by an optical sensor. Table II lists the number of commercial-off-the shelf directional couplers and their characteristic performance. Following the sensor, the grating with a single wavelength operation reflects the signal of the predetermined wavelength; for example, λ_1 uniquely identifies sensor 1 in figure 1. The reflected signal is returned to the optical bus fiber and converges on the receiver point where it can then be detected by a photodetector.

TABLE II.—CHARACTERISTIC PERFORMANCE OF COMMERCIAL-OFF-THE-SHELF COUPLER COMPONENTS [Operating temperatures, -20 to 85 °C.]

Type	Operating wavelength, nm	Insertion loss, dB	Uniformity, dB
1×2	630	3.8	1.1
1×2	780	3.8	1.1
1×2	850	3.8	1.1
1×2	1310	3.4	.5
1×2	1550	3.4	.6
1×4	1310	6.7	.7
1×4	1550	7	.8

From figure 1, the receiver block can accommodate more than one sensor at the local detection region. To increase the number of sensors at a localized region, a WDM module is used between the directional coupler and detector so that a separate optical wavelength emerging from the WDM module can match the wavelengths specifically assigned to Bragg grating modules (fig. 2). The result of the separation of wavelengths from the WDM module generates two carrier wavelengths λ_1 and λ_2 , which in turn pass through each sensor, including sensors 1A and 1B. These amplitude signals are filtered by the fiber Bragg grating modules and are then detected by photodetectors located close to the sensors. As a result, signals from many different sensors within a local region can be readily detected using a combination of WDM and Bragg grating modules.

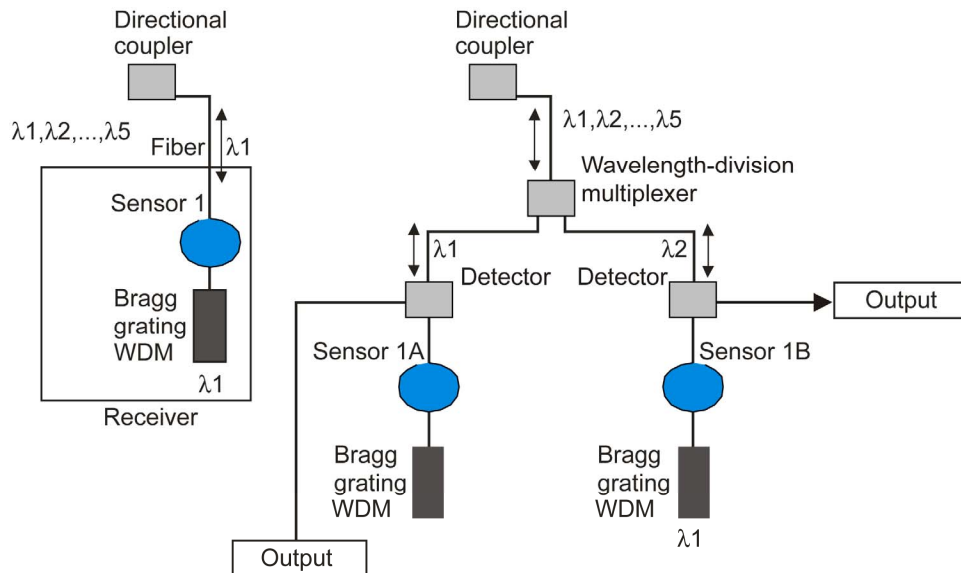

Figure 2.—Localized detection at receiver block with more than one sensor using set of components (wavelength-division multiplexer, photodetector, and Bragg grating module).

Optical Power Budget Evaluations in Relation to Bit Error Rate (BER), Signal-to-Noise Ratio (SNR), and Bandwidth

Since each wavelength can support a series of electrical multiplexing signals, it is essential that one understand the system requirements of average received optical power in relation to bit rate and bandwidth for both digital and analog signals. For digital signals at a bit error rate (BER) of 10^{-9} , the calculated average received optical power result shown in figure 3(a) indicates that the minimum power at 100 Mbps for a nonreturn-to-zero signal is -36 dBm for the positive intrinsic negative (PIN) and -62 dBm for the Avalanche photodiode. The average received optical power for analog signals at a 100-MHz bandwidth requires -5 dBm for a signal-to-noise ratio (SNR) of 70 dB, -30 dBm for a SNR of 40 dB, and -72 dBm for a SNR of 0 dB, as shown in figure 3(b). The bandwidths of the multimode and single-mode fibers with diameters of 50 and 9 μm , respectively, are presented in figures 4(a) and (b) in terms of wavelength.

An optical amplifier, such as commercial erbium-doped fiber amplifier (EDFA), can be used to compensate for losses that emerge from couplers and multiplexing operations. The EDFA module can achieve a small signal gain of greater than 30 dB utilizing 980-nm pump lasers that launch about 120 mW of optical power into gain stages. The gain stage is normally located between two fiber optic isolators to prevent backreflection into the input light source. Most commercial amplifiers operate in the wavelength range of 730 to 1563 nm and produce a saturated output power of more than 15 dBm with an input signal of -5 dBm (ref. 9).

In the receiver module, photodiode arrays of InGaAs (indium-gallium-arsenite) lattice-matched to InP (indium-phosphide) are highly preferable for monitoring amplitude or phase signals in WDM networks because of their reliable and robust integrated optical devices. They are commercially available with a configuration choice of up to 512 elements multiplexed with CMOS (complementary metal oxide semiconductor) readout integrated circuits (ref. 10). Quantum efficiencies during operation are greater than 80 percent between the wavelength range of 0.9 and 1.7 μm and the cutoff wavelength of 1.6 μm . Such performance makes them ideally suited to wideband wavelength operations for optical sensing devices. Table III summarizes the requirements and specifications of a commercial receiver module that will support the WDM optical network model described in figure 1.

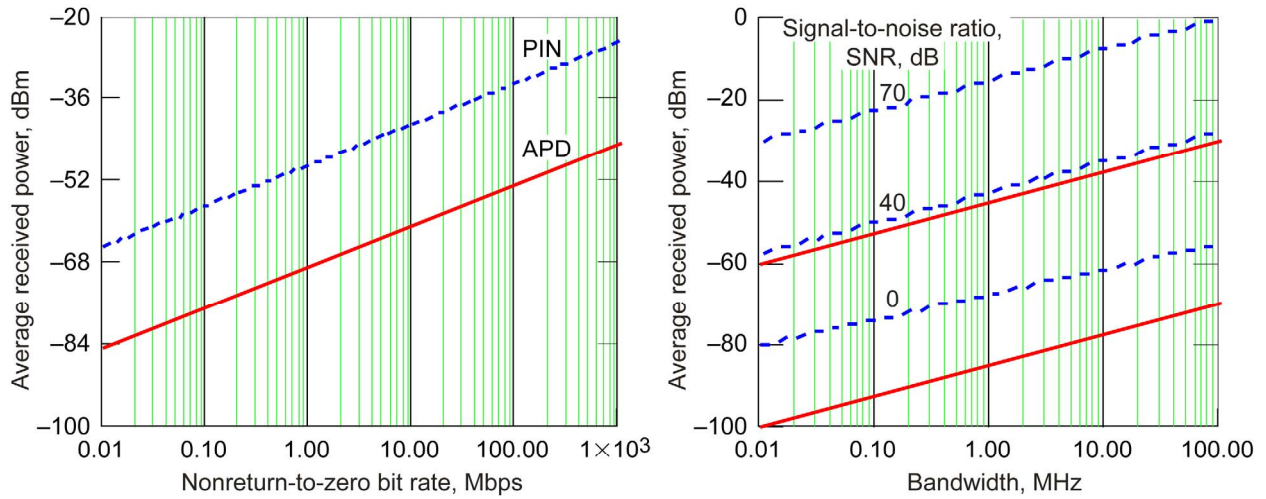

Figure 3.—Calculated average received optical power relative to bit error rate (BER), signal-to-noise ratio (SNR), and bandwidth. (a) Digital signal at BER of 10^{-9} . PIN, positive intrinsic negative; APD, Avalanche photodiode. (b) Analog signal at bandwidth of 100 MHz.

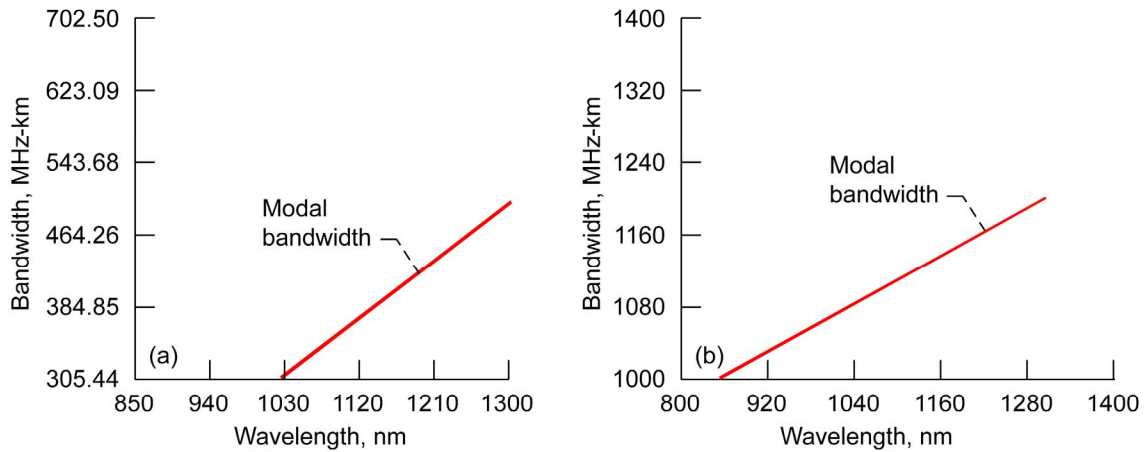

Figure 4.—Calculated signal bandwidth versus wavelengths for multimode and single-mode fibers. (a) Multimode fiber diameter, 50 μm . (b) Single-mode fiber diameter, 9 μm .

TABLE III.—SPECIFICATION PARAMETERS FOR RECEIVER MODULE

[Operational temperatures, -25 to 95 $^{\circ}\text{C}$.]

Spectral range, μm	0.19 to 1.1	0.4 to 1.1	0.78 to 1.8	0.8 to 1.65
Power average, W/cm^2	0.2	2	2	3
Uniformity, percent	± 2	± 1	± 1	± 2
Responsivity, A/W	>0.4	>0.1	>0.2	>0.3
Rise time, μs	<2	<2	<3	<2
Material	Silicon	Silicon	Germanium	Indium-gallium-arsenite

Conclusion

A wavelength-division multiplexing (WDM) optical networking model for data signal detection from various sensors using the Bragg grating module is presented. As compared with other technologies, the advantage of using WDM optical networks is that they are more adaptable to a wide spectrum of wavelengths that emerge from the different types of optical sensors, such as time-division multiplexing (TDM), frequency-division multiplexing (FDM), and subcarrier multiplexing (SCM). However, a drawback of this method is that several components of the WDM (the transceiver, coupler, multiplexer/demultiplexer, and routers) tend to shift away from their carrier wavelengths, particularly in high-temperature environments. Therefore, this method tends to be most applicable to room-temperature environments. Since each wavelength can support a series of electrical multiplexing signals, it is essential that one understand the system requirements of average received optical power in relation to bit rate and bandwidth for both digital and analog signals.

References

1. Zirngibl, M., et al.: LARnet, A Local Access Router Network. *IEEE Photon. Technol. Lett.*, vol. 7, issue 8, 1995, pp. 215–217.
2. Fan, Chun; Maier, Martin; and Reisslein, Martin: The AWG||PSC Network: A Performance-Enhanced Single-Hop WDM Network With Heterogeneous Protection. *J. Lightwave Technol.*, vol. 22, no. 5, 2004, pp. 1242–1262.
3. Guo, Duanyang; and Acampora, A.S.: Scalable Multihop WDM Passive Ring With Optimal Wavelength Assignment and Adaptive Wavelength Routing. *J. Lightwave Technol.*, vol. 14, issue 6, 1996, pp. 1264–1277.
4. Lin, Wen-Piao; Kao, Ming-Seng; and Chi, Sien: The Modified Star-Ring Architecture for High-Capacity Subcarrier Multiplexed Passive Optical Networks. *J. Lightwave Technol.*, vol. 19, issue 1, 2001, pp. 32–39.
5. Brackett, C.A.: Dense Wavelength Division Multiplexing Networks: Principles and Applications. *IEEE J. Sel. Areas Commun.*, vol. 8, issue 6, 1990, pp. 948–964.
6. Lee, T.P.; and Zah, C.-E.: Wavelength-Tunable and Single-Frequency Semiconductor Lasers for Photonic Communications Networks. *IEEE Commun. Mag.*, vol. 27, issue 10, 1989, pp. 42–52.
7. Hernandez-Lorenzo, R.; Lopez-Amo, M.; and Urquhart, P.: Single and Double Distributed Optical Amplifier Fiber Bus Networks With Wavelength Division Multiplexing for Photonic Sensors. *J. Lightwave Technol.*, vol. 16, issue 4, 1998, pp. 485–489.
8. Abad, S.; et al.: Comparative Analysis of Wavelength-Multiplexed Photonic-Sensor Networks Using Fused Biconical WDMS. *IEEE Sensors J.*, vol. 3, issue 4, 2003, pp. 475–483.
9. Staffan Bjorlin, E.; and Bowers, J.E.: Noise Figure of Vertical-Cavity Semiconductor Optical Amplifiers. *IEEE J. Quantum Electron.*, vol. 38, issue 1, 2002, pp. 61–66.
10. Chen, O.T.-C., et al.: Extended One-Dimensional Analysis to Effectively Derive Quantum Efficiency of Various CMOS Photodiodes. *IEEE Trans. Electron Devices*, vol. 54, issue 10, 2007, pp. 2659–2668.

REPORT DOCUMENTATION PAGE

Form Approved
OMB No. 0704-0188

The public reporting burden for this collection of information is estimated to average 1 hour per response, including the time for reviewing instructions, searching existing data sources, gathering and maintaining the data needed, and completing and reviewing the collection of information. Send comments regarding this burden estimate or any other aspect of this collection of information, including suggestions for reducing this burden, to Department of Defense, Washington Headquarters Services, Directorate for Information Operations and Reports (0704-0188), 1215 Jefferson Davis Highway, Suite 1204, Arlington, VA 22202-4302. Respondents should be aware that notwithstanding any other provision of law, no person shall be subject to any penalty for failing to comply with a collection of information if it does not display a currently valid OMB control number.

PLEASE DO NOT RETURN YOUR FORM TO THE ABOVE ADDRESS.

1. REPORT DATE (DD-MM-YYYY) 01-09-2008		2. REPORT TYPE Technical Memorandum		3. DATES COVERED (From - To)	
4. TITLE AND SUBTITLE Data Optical Networking Architecture Using Wavelength-Division Multiplexing Method for Optical Sensors				5a. CONTRACT NUMBER	
				5b. GRANT NUMBER	
				5c. PROGRAM ELEMENT NUMBER	
6. AUTHOR(S) Nguyen, Hung, D.				5d. PROJECT NUMBER	
				5e. TASK NUMBER	
				5f. WORK UNIT NUMBER WBS 645846.02.07.03.05	
7. PERFORMING ORGANIZATION NAME(S) AND ADDRESS(ES) National Aeronautics and Space Administration John H. Glenn Research Center at Lewis Field Cleveland, Ohio 44135-3191				8. PERFORMING ORGANIZATION REPORT NUMBER E-16524	
9. SPONSORING/MONITORING AGENCY NAME(S) AND ADDRESS(ES) National Aeronautics and Space Administration Washington, DC 20546-0001				10. SPONSORING/MONITORS ACRONYM(S) NASA	
				11. SPONSORING/MONITORING REPORT NUMBER NASA/TM-2008-215258	
12. DISTRIBUTION/AVAILABILITY STATEMENT Unclassified-Unlimited Subject Category: 04 Available electronically at http://gltrs.grc.nasa.gov This publication is available from the NASA Center for AeroSpace Information, 301-621-0390					
13. SUPPLEMENTARY NOTES					
14. ABSTRACT Recently there has been a growth in the number of fiber optical sensors used for health monitoring in the hostile environment of commercial aircraft. Health monitoring to detect the onset of failure in structural systems from such causes as corrosion, stress corrosion cracking, and fatigue is a critical factor in safety as well in aircraft maintenance costs. This report presents an assessment of an analysis model of optical data networking architectures used for monitoring data signals among these optical sensors. Our model is focused on the design concept of the wavelength-division multiplexing (WDM) method since most of the optical sensors deployed in the aircraft for health monitoring typically operate in a wide spectrum of optical wavelengths from 710 to 1550 nm.					
15. SUBJECT TERMS Fiber; Sensors; Wavelength division multiplexing; Networking					
16. SECURITY CLASSIFICATION OF:			17. LIMITATION OF ABSTRACT	18. NUMBER OF PAGES	19a. NAME OF RESPONSIBLE PERSON
a. REPORT	b. ABSTRACT	c. THIS PAGE			19b. TELEPHONE NUMBER (include area code)
U	U	U	UU	12	STI Help Desk (email: help@sti.nasa.gov) 301-621-0390

