



Total Dose Effects on Error Rates in Linear Bipolar Systems

Stephen Buchner¹, Dale McMorrow²,
Muriel Bernard³, Nicolas Roche³
and Laurent Dusseau³.

1. PSGS/NASA-GSFC, USA
2. Naval Research Laboratory, USA
3. University of Montpellier, France

To be presented by S. Buchner at 9th European Conference Radiation and Its Effects on Components and Systems (RADECS07), September 10, 2007, Deauville, France.

1

Introduction

- Analog SETs (ASET) can propagate through a system and cause a malfunction.
- Following radiation exposure, ASETs in LM139 become smaller → System error rate decreases.

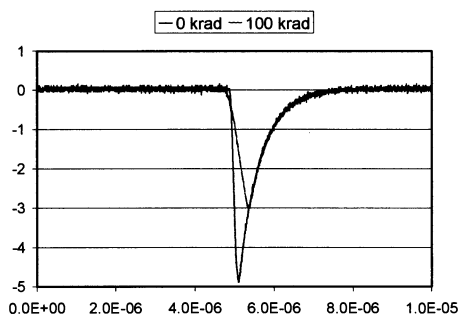

LM139
Voltage Comparator

To be presented by S. Buchner at 9th European Conference Radiation and Its Effects on Components and Systems (RADECS07), September 10, 2007, Deauville, France.

2

Introduction

- LM124 is an op-amp with a much larger variety of SETs.

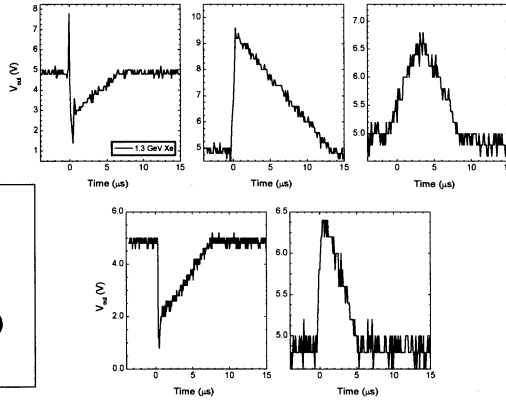

What happens to the SETs following TID irradiation?

To be presented by S. Buchner at 9th European Conference Radiation and Its Effects on Components and Systems (RADECS07), September 10, 2007, Deauville, France.

3

LM124 Configuration

- LM124 is a quad op-amp. Configured in three ways: Voltage follower, Inverter, Non-Inverter.
- Irradiated to 150 krad(Si) under bias, i.e., $V_{in} = 1V$.

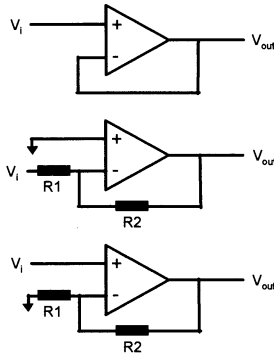

Radiation causes a reduction in transistor gain and a loss of transistor current drive.

To be presented by S. Buchner at 9th European Conference Radiation and Its Effects on Components and Systems (RADECS07), September 10, 2007, Deauville, France.

4

Pulsed Laser Data

To be presented by S. Buchner at 9th European Conference Radiation and Its Effects on Components and Systems (RADECS07), September 10, 2007, Deauville, France.

5

LM124 Circuit

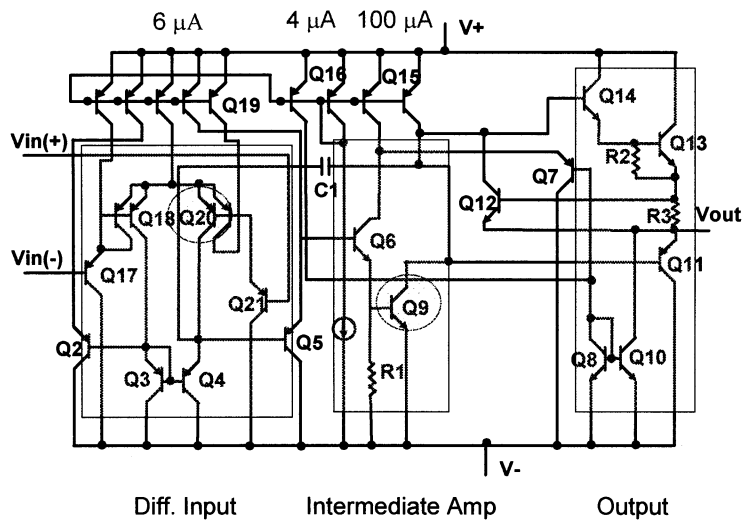

To be presented by S. Buchner at 9th European Conference Radiation and Its Effects on Components and Systems (RADECS07), September 10, 2007, Deauville, France.

6

LM124 Photomicrograph

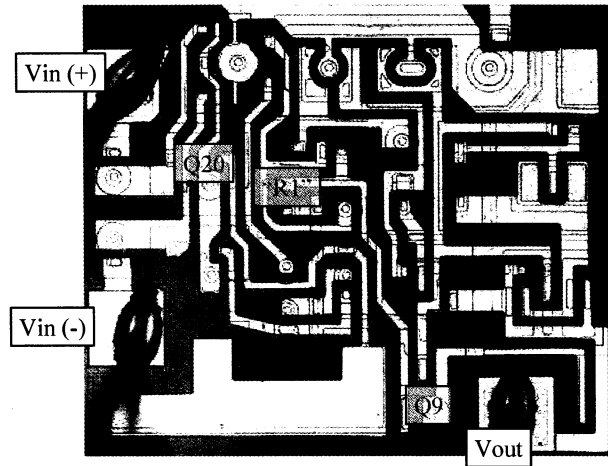

To be presented by S. Buchner at 9th European Conference Radiation and Its Effects on Components and Systems (RADECS07), September 10, 2007, Deauville, France.

7

SETs in Pristine Device

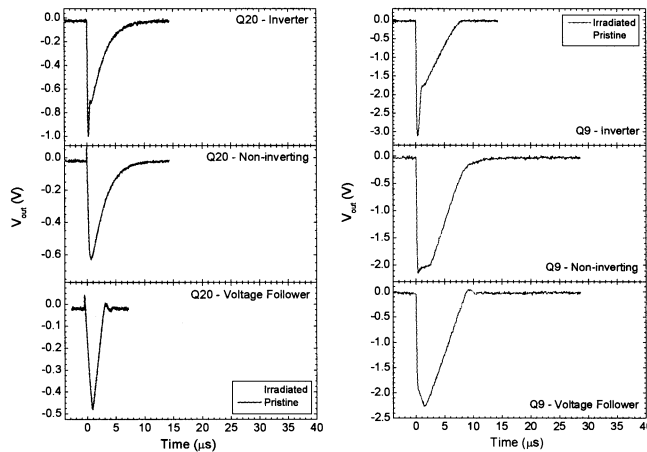

To be presented by S. Buchner at 9th European Conference Radiation and Its Effects on Components and Systems (RADECS07), September 10, 2007, Deauville, France.

8

SETs Before and After Irradiation

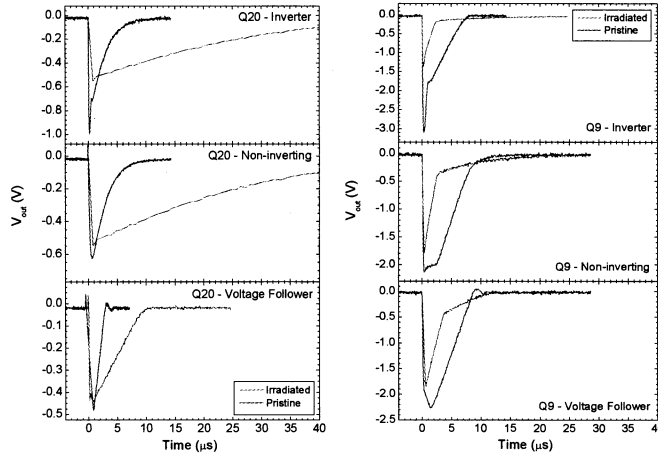

To be presented by S. Buchner at 9th European Conference Radiation and Its Effects on Components and Systems (RADECS07), September 10, 2007, Deauville, France.

9

Explanation for SETs on Q20 & Q9

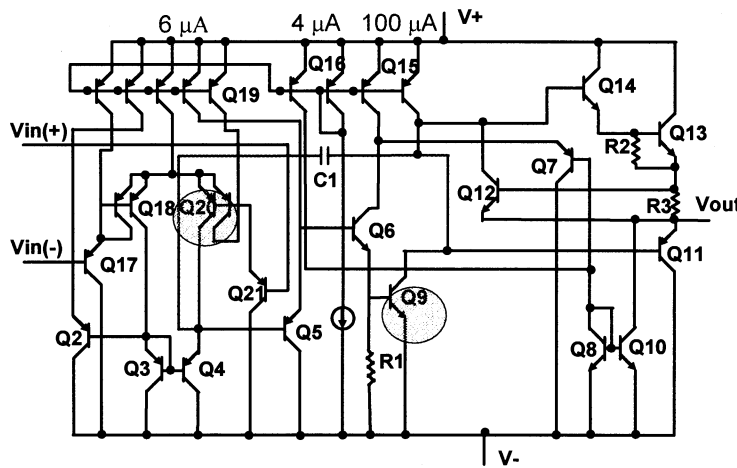

To be presented by S. Buchner at 9th European Conference Radiation and Its Effects on Components and Systems (RADECS07), September 10, 2007, Deauville, France.

10

Heavy Ion Data

To be presented by S. Buchner at 9th European Conference Radiation and Its Effects on Components and Systems (RADECS07),
September 10, 2007, Deauville, France.

11

LET=54.8 MeV.cm²/mg

Unirradiated

Inverter

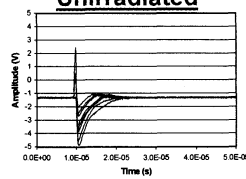

Voltage Follower

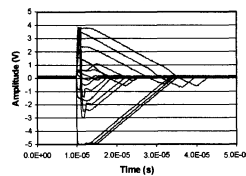

Non-Inverter

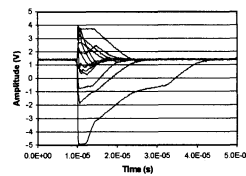

To be presented by S. Buchner at 9th European Conference Radiation and Its Effects on Components and Systems (RADECS07),
September 10, 2007, Deauville, France.

12

LET=54.8 MeV.cm²/mg

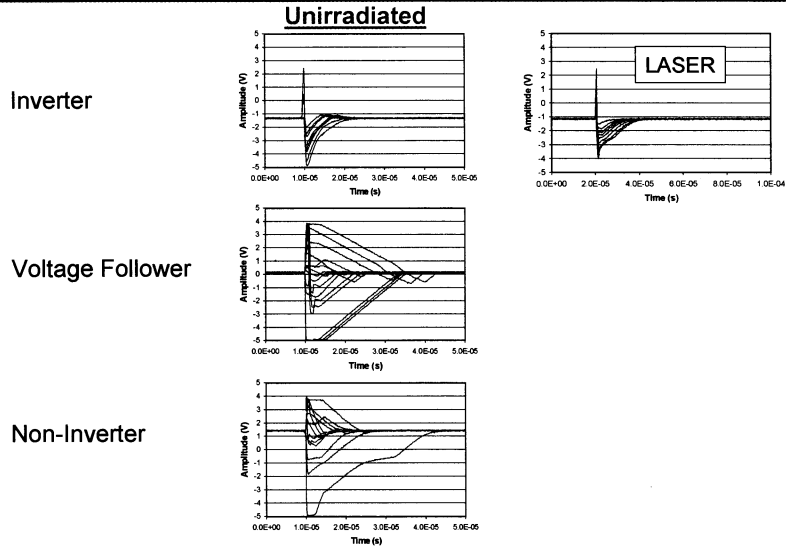

To be presented by S. Buchner at 9th European Conference Radiation and Its Effects on Components and Systems (RADECS07), September 10, 2007, Deauville, France.

13

LET=54.8 MeV.cm²/mg

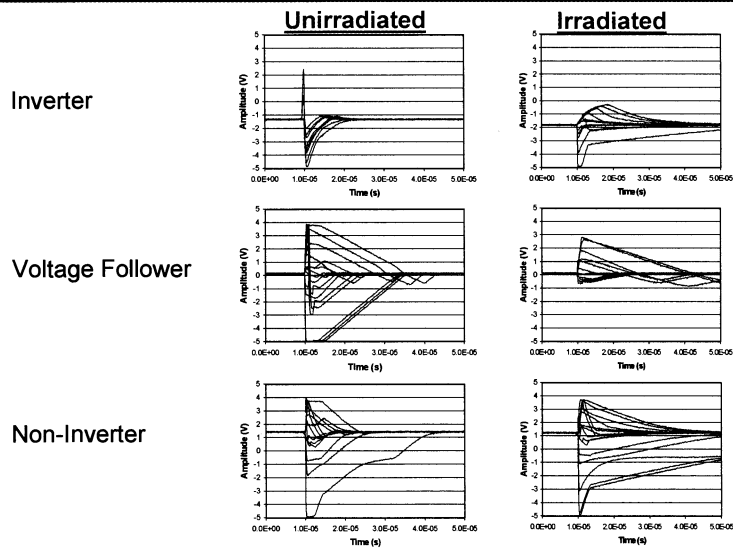

To be presented by S. Buchner at 9th European Conference Radiation and Its Effects on Components and Systems (RADECS07), September 10, 2007, Deauville, France.

14

Application

Heavy Ion Strike on LM124

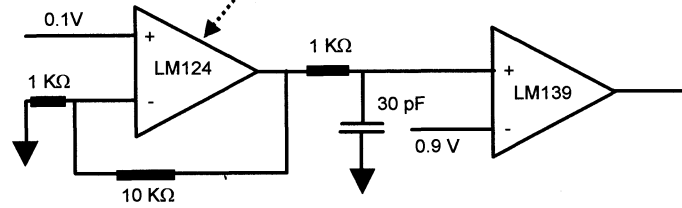

To be presented by S. Buchner at 9th European Conference Radiation and Its Effects on Components and Systems (RADECS07), September 10, 2007, Deauville, France.

15

Plots of SET Amplitude vs Width

Non-Inverter

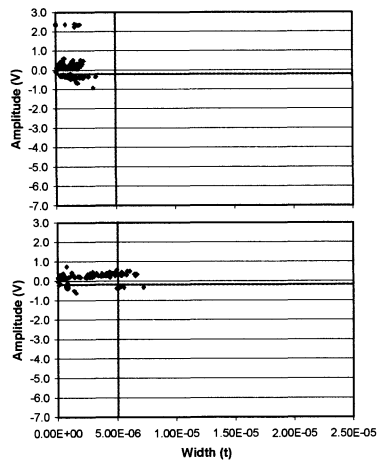

LET=2.8 MeV.cm²/mg

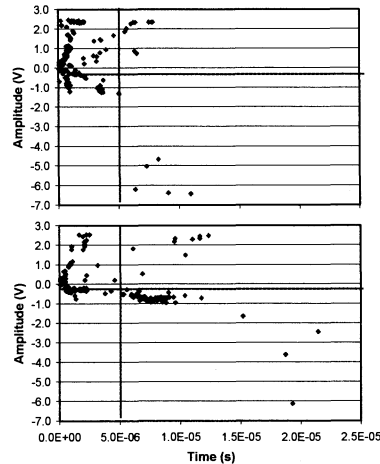

LET=54.8 MeV.cm²/mg

To be presented by S. Buchner at 9th European Conference Radiation and Its Effects on Components and Systems (RADECS07), September 10, 2007, Deauville, France.

16

LM124 Laser Induced Transients

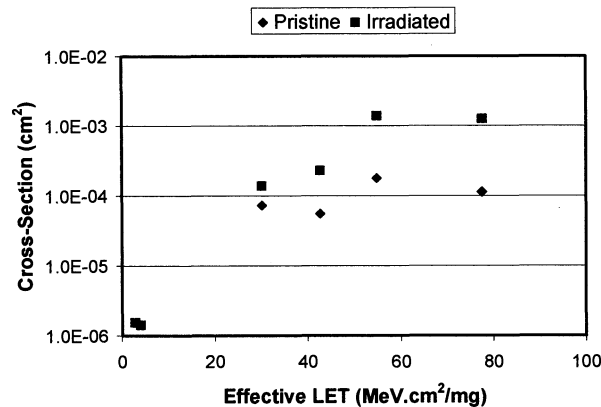

To be presented by S. Buchner at 9th European Conference Radiation and Its Effects on Components and Systems (RADECS07), September 10, 2007, Deauville, France.

17

Conclusions

- SET shapes depend on:
 - Configuration – different transistors sensitive
 - Radiation exposure – degrades gain and current drive
- Understanding of how TID affects transistor operation together with simple circuit analysis can explain changes in SET shapes with dose.
- Depending on origin, SET widths can increase or decrease following exposure.
- System SET rate can change with radiation exposure.

To be presented by S. Buchner at 9th European Conference Radiation and Its Effects on Components and Systems (RADECS07), September 10, 2007, Deauville, France.

18

Total Dose Effects on Error Rates in Linear Bipolar Systems

Stephen Buchner, *Member, IEEE*, Dale McMorrow, *Member, IEEE*, Muriel Bernard, Student *Member, IEEE*, Nicolas Roche, and Laurent Dusseau, Senior *Member, IEEE*.

Abstract— The shapes of single event transients in linear bipolar circuits are distorted by exposure to total ionizing dose radiation. Some transients become broader and others become narrower. Such distortions may affect SET system error rates in a radiation environment. If the transients are broadened by TID, the error rate could increase during the course of a mission, a possibility that has implications for hardness assurance.

Index Terms—Bipolar circuit, single event transient, total dose, error rate.

I. INTRODUCTION

Single Event Transients (SETs) originating in linear bipolar integrated circuits are known to undermine the reliability of electronic systems operating in the radiation environment of space [1]. For example, in 2001 a SET caused a computer on board NASA's Microwave Anisotropy Probe to unexpectedly reset [2]. This interruption resulted in a shutdown of most spacecraft systems for almost a week. Eventually the cause was determined to be a SET that occurred in an LM139 comparator connected to the computer's reset button. Fortunately, only scientific data were lost during shutdown.

Ionizing particle radiation produces a variety of SETs in linear bipolar circuits. The extent to which these SETs threaten system reliability depends on both their shapes (amplitude and width) and their threshold energies. In general, SETs with large amplitudes and widths are the most likely to propagate from a bipolar circuit's output through a subsystem. The danger these SET pose is that, if they become latched in a

follow-on circuit, they could cause an erroneous system response.

Long-term exposure of linear bipolar circuits to particle radiation produces total ionizing dose (TID) and/or displacement damage dose (DDD) effects that are characterized by a gradual degradation in some of the circuit's electrical parameters. For example, an operational amplifier's gain-bandwidth product is reduced by exposure to ionizing radiation, and it is this reduction that contributes to the distortion of the SET shapes. Depending on the nature of the parametric degradation and the associated modifications to SET shapes and thresholds, the error rate could either increase or decrease with TID and DDD. Ignoring such changes in a system designed to be immune to SETs at the beginning of a mission could lead to it becoming more vulnerable near the end of the mission.

Previous work found that the SET threshold in a linear bipolar circuit (LM119) depends on exposure to particle radiation [3]. That report was concerned with radiation damage (TID and DDD) induced by low-energy protons. Measurements with a pulsed laser indicated a monotonic increase in the SET threshold energy with proton fluence, suggesting that SETs become less of a threat following radiation exposure.

A recent paper presents a detailed analysis of the effects that TID can have on the shapes and sensitivities of SETs in a simple voltage comparator (LM139) [4]. The SETs are relatively uncomplicated, being negative-going when the output of the comparator is "high" and positive-going when the output is "low". For the case where the output is "high", TID causes the slope of the leading edge of the SET (determined by the comparator's slew rate) to decrease, resulting in SETs with reduced amplitudes. TID has no effect on the trailing edge, which is determined by the value of the resistor (connected between the open collector and the positive power supply) and the capacitance of the LM139's output transistor. These results suggest that the expected SET rate in space decreases with dose.

SETs in operational amplifiers, such as the LM124, have a much greater variety of shapes and sizes than do simple voltage comparators, making the LM124 an ideal device for gaining a better understanding of how TID exposure affects SETs [1]. A number of factors, such as supply voltage, feedback, gain, configuration and particle LET, are known to affect the shapes of SETs, but there are no published reports on how SETs are affected by TID/DDD.

Manuscript received September 6, 2007. This work was supported in part by NASA's Electronic Parts and Packaging Program.

Stephen Buchner is with Perot Systems Government Services at NASA Goddard Space Flight Center, Greenbelt, MD 20771 USA (phone: 301-286-5019; fax: 301-286-4699; e-mail: sbuchner@pop500.gsfc.nasa.gov).

Dale McMorrow is with the Naval Research Laboratory, Washington DC 20375 USA (e-mail: mcmorrow@ccs.nrl.navy.mil)

Muriel Bernard is with Université Montpellier II, F-34095 Montpellier cedex 5, France (e-mail: bernard@ies.univ-montp2.fr).

Laurent Dusseau is with Université Montpellier II, F-34095 Montpellier cedex 5, France (e-mail: dusseau@ies.univ-montp2.fr).

Nicolas Roche is with Université Montpellier II, F-34095 Montpellier cedex 5, France (e-mail: nicolas.roche@ies.univ-montp2.fr).

In this paper, we compare SETs produced in a pristine LM124 operational amplifier with those produced in one exposed to ionizing radiation for three different operating configurations – voltage follower (VF), inverter with gain (IWG), and non-inverter with gain (NIWG). Each configuration produces a unique set of transient shapes that change following exposure to ionizing radiation. An important finding is that the changes depend on operating configuration; some SETs decrease in amplitude, some remain relatively unchanged, some become narrower and some become broader.

To illustrate how radiation exposure can, in fact, change the SET rate, we consider an example where the SET rate increases with TID.

II. DEVICE DESCRIPTION.

The device tested was a National Semiconductor LM124 quad operational amplifier in a dual in-line package (DIP) with a metal lid. To enable the laser light and heavy ions to reach the die, the lid was removed prior to radiation exposure. Three of the four amplifiers in the package were tested, each in a different configuration – VF, IWG and NIWG. The fourth one was not connected. Fig. 1 shows the configurations.

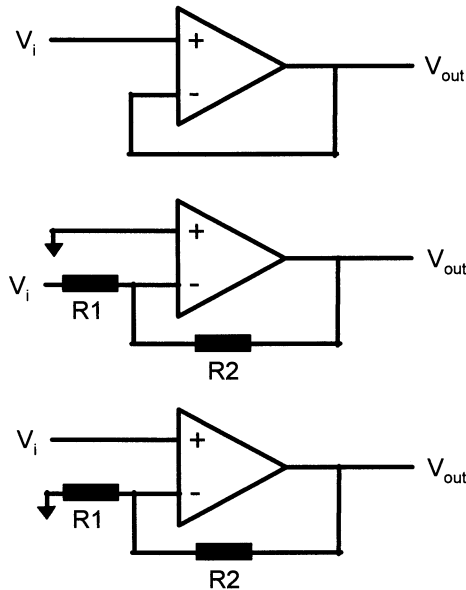

Fig. 1. Three operating configurations tested for the LM124. The top shows a voltage follower, the middle shows an inverter with gain, and the bottom shows a non-inverter with gain. The values of the resistors are $R1 = 1 \text{ k}\Omega$ and $R2 = 10 \text{ k}\Omega$. The gains are 1, -10 and 11, respectively.

Fig. 2 is a circuit diagram of the LM124. Many of the transistors in the circuit are SET sensitive and their identities have previously been established using the pulsed laser [5]. During accelerator testing, the entire chip is exposed to a beam of heavy ions whose arrival times and strike locations are random. As a result, each run contains SETs with a variety of shapes. The number of each type of SET captured depends on the threshold energy and cross-section for each sensitive transistor.

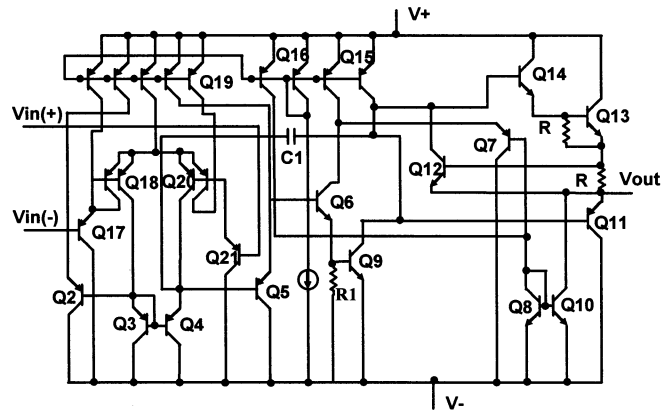

Fig. 2. Circuit diagram of the LM124. The differential input stage is on the left, the intermediate amplifier stage is in the middle, and the output stage is on the right.

III. TEST METHOD.

An LM124 was mounted in a socket on a test board that had connections for power supply and input power. The device was exposed to gamma radiation in the NASA/GSFC Co^{60} cell. During exposure, electrical bias was applied to the device, i.e., $V_{in} = 1 \text{ V}$ and $V_{dd} = 5 \text{ V}$ and $V_{ss} = -5 \text{ V}$. Outputs were left floating.

The part was irradiated at a high dose rate of 5 krad(Si)/hour to a total dose of 150 krad(Si) . Although the LM124 is known to have enhanced low dose rate sensitivity, a high dose rate was chosen because of time constraints. The large total dose ensured that radiation-induced changes in electrical parameters, specifically gain and transistor current drive, would be sufficient to noticeably distort the SETs.

The irradiated device and a pristine device from the same lot/date code were tested for SETs using pulsed laser light and heavy ions. All SET testing was done with V_{in} set to 0.13 V , so that V_{out} was 0.13 V for the VF, 1.43 V for the NIWG, and -1.3 V for the IWG.

A. Pulsed-Laser Testing

Testing with pulsed-laser light was performed at the Naval Research Laboratory. The laser generates 1 ps pulses at a wavelength of 590 nm and a repetition rate of 1 kHz . The light is focused to a spot with a full-width-at-half-maximum diameter of $1.1 \mu\text{m}$ and directed at transistor areas exhibiting sensitivity to SETs. This type of spatial information, not available with accelerator testing, makes it possible to compare directly SETs from the same sensitive areas from the same transistors in each of the three differently configured op-amps. Then, by replacing the pristine device with an irradiated one, it is possible to determine how a TID of 150 krad(Si) alters the shapes of the SETs for all three configurations. All measurements were performed with constant laser pulse energy (4.3 pJ) to ensure a valid comparison among the SETs could be made. A high-speed oscilloscope probe (capacitance of 8 pF) was attached directly to the op-amp output. SETs were captured on a digital oscilloscope and stored for later analysis.

TABLE I
HEAVY IONS USED FOR SET TESTING

Ion	Angle	Effective LET (MeV.cm ² /mg)
Ne	0	2.8
Ne	45	4
Kr	0	30.1
Kr	45	42.6
Xe	0	54.8
Xe	45	77.5

B. Heavy-Ion Testing

Heavy-ion testing was conducted at Texas A&M Cyclotron Facility using the 15 MeV/amu energy tune. In order to capture both positive and negative transients, two oscilloscope probes were attached to an output and connected to two separate oscilloscope channels. One channel was set to trigger on a positive voltage deviation of +50 mV and the other on a negative deviation of -50 mV. Approximately four hundred transients were captured for each run. Table I shows the ions used and their effective LETs.

IV. RESULTS

A. Pulsed-Laser Results

Previous work with pulsed laser light and heavy ions revealed the variety of SET shapes in the LM124 [5]. With the focused light of the pulsed laser it is possible to identify transistors responsible for producing particular SET shapes. Some SETs are positive, some are negative, and some have bipolar structure. In this work, we have focused on Q9 and Q20, both of which produce negative-going SETs in all three configurations, and R1, which produces bipolar SETs. Transistor Q20 is part of the differential input circuit, Q9 is in the intermediate stage, and R1 is connected between the base of Q9 and V_{ss} in the intermediate stage.

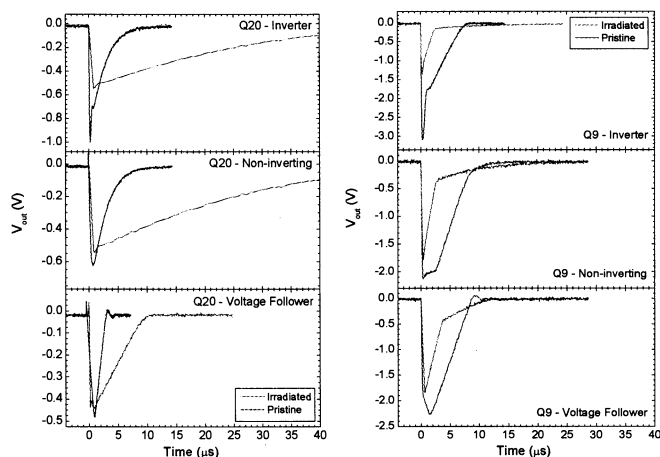

Fig. 3. SETs obtained for the LM124 in three different operating configurations for a pristine and an irradiated device. The left panel is for transistor Q20 and the right panel is for transistor Q9. (With the oscilloscope in AC mode, the baseline is at 0V).

Fig. 3 compares SETs generated when the laser is focused on transistor Q20 (left panel) and transistor Q9 (right panel). Note that for these experiments the oscilloscope was set to AC mode, resulting in the baseline being at 0V. The figure shows modest pre-rad differences in shape for SETs generated at transistor Q20 in each of the three different configurations. IWG has the largest SET amplitude (~1V), whereas VF has the smallest (~0.5V). All three SETs have widths (FWHM) of between 2 and 3 μs. Following exposure to ionizing radiation, only SETs in the IWG configuration exhibit a significant reduction in amplitude (up to 50%). More noticeable are changes in SET width for IWG and NIWG configurations, which increase from 2 μs to 19 μs. This may be contrasted with the SETs for the VF configuration, for which the width increases from 2 μs to 5 μs.

Results for SETs originating in transistor Q9 are very different from those originating in Q20. While those of transistor Q9 for the VF and NIWG configurations are quite similar in shape and size and only slightly wider than SETs in the IWG configuration, their widths become much narrower following irradiation, decreasing to less than half the pre-irradiation value. At the same time, the amplitudes are reduced only marginally for the VF and NIWG configurations, but quite significantly for the IWG configuration.

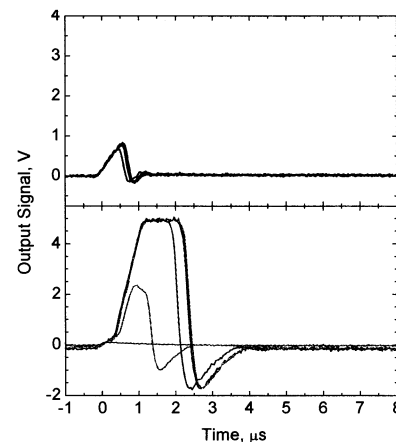

Fig. 4. SETs generated in resistor (R1) for the IWG configuration. The top traces are SETs in an irradiated device as a function of laser pulse energy. The bottom traces are SETs in a pristine device using the same set of pulse energy values. The pulse energies were 0.24, 0.36, 0.48, 0.60, and 0.72 pJ.

Fig. 4 shows SETs obtained for pulsed laser light focused on R1. Although R1 acts as a resistor, its structure is that of a transistor with a floating base [6]. SETs originating in R1 have shapes that are extremely sensitive to parasitic output capacitance of the measuring apparatus. With increasing capacitance, the shape of the SET changes from a square wave with positive amplitude to one that is bipolar with an increasing negative component. The small negative component in the figure is due to the relatively small capacitance of the probe connected to the output. SETs in the pristine part retain their bipolar character when the deposited energy is varied. The SET amplitudes and shapes of the

irradiated part are very different from those in the pristine part, having a basic triangular shape with only small negative component and small amplitude. SETs for the other two configurations (VF and NIWG) are similar and are, therefore, not shown.

B. Heavy-Ion Results

SETs were captured for all three operating configurations and for a number of different ion effective LETs. The electrical conditions are identical to those used for pulsed-laser testing, i.e., $V_{dd} = 5V$, $V_{ss} = -5V$ and $V_{in} = 0.13V$. However, the experimental conditions differed slightly in that two active probes were attached to an output during heavy-ion testing, the cables connecting the probes to the oscilloscope were longer than for the pulsed laser case, and the oscilloscope was operating in the DC mode. Fig. 5 compares SETs for the pristine part (left panel) and irradiated part (right panel) for an LET of $54.8 \text{ MeV}\cdot\text{cm}^2/\text{mg}$. Of the numerous data sets, only those obtained with ions having an LET of $54.8 \text{ MeV}\cdot\text{cm}^2/\text{mg}$ are presented in Fig. 5 because they best illustrate the variety of possible SET shapes and sizes. (For purposes of clarity, only a small fraction of the more than 400 SETs captured for each run are included).

The graphs reveal a number of interesting characteristics. First, the shapes of SETs in pristine devices depend strongly on the operating configuration. Whereas all the SETs in the IWG are bipolar, those in the other two configurations have a variety of shapes and sizes, including positive, negative and bipolar.

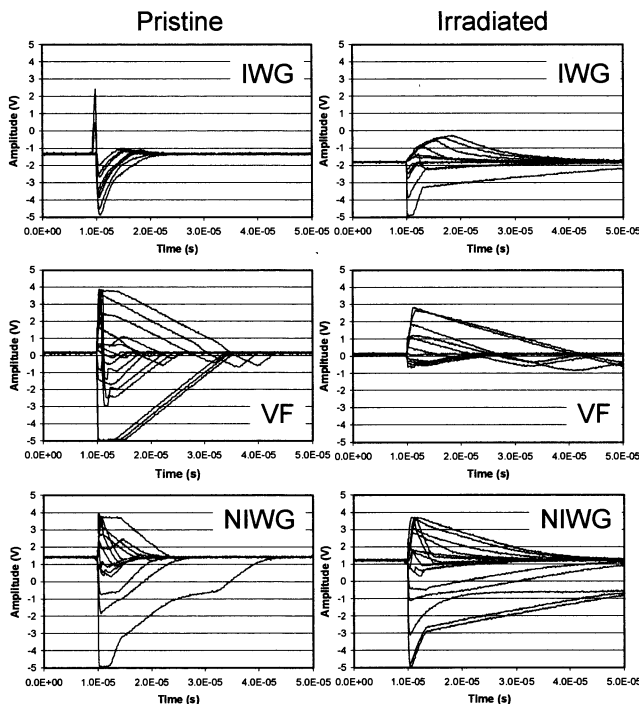

Fig. 5. Heavy-ion induced SETs for pristine (left panel) and irradiated (right panel) devices for IWG (top), VF (middle) and NIWG (bottom) at $\text{LET}=54.8 \text{ MeV}\cdot\text{cm}^2/\text{mg}$.

Second, the fact that all the SETs in the IWG have the same bipolar shape strongly suggests that all originate from a single location.

Third, comparison of the left and right panels in Fig. 5 reveal dramatic change in the SET shapes observed for all three configurations following irradiation. The bipolar SETs observed for the IWG are almost completely absent in the irradiated part, having been replaced by unipolar positive and negative transients with significantly greater widths. In the VF, not only are the negative SETs largely absent following irradiation, but they generally have smaller amplitudes and are wider by a factor of about two. For the NIWG, the presence of both positive and negative SETs does not change appreciably following TID. However, the SET widths become considerably broader.

V. DISCUSSION

A. Pulsed-Laser Results

Fig. 3 perfectly illustrates the oft-stated fact that SET pulse shapes differ among different operating conditions for the same bipolar circuit, i.e., whereas SETs in the VF and IWG are similar in shape, those for the IWG are narrower and larger.

Radiation-induced distortions in the shapes of SETs can be explained by invoking known TID effects in bipolar transistors, together with simple circuit analysis. TID causes a reduction in a bipolar transistor's gain as well as its drive capacity. Combining that information with circuit analysis makes it possible to explain radiation-induced changes in SET shapes in the LM124. The LM124, which consists of a differential input stage, an intermediate amplifier stage and an output stage, also contains a decoupling capacitor between the input and intermediate stages. The capacitor plays a crucial role in determining SET shapes, especially following exposure to ionizing radiation.

SETs originating on Q9

Q9, located in the intermediate amplifier section and connected to a $100 \mu\text{A}$ current source, acts as a small-signal voltage amplifier. For the LM124 in the IWG configuration V_{out} is connected to $-V_{in}$ through a resistor bridge, providing negative feedback. Injecting charge into transistor Q9 with laser light turns Q9 on and causes current to be shunted to V_{ss} , which lowers the potential on the base of Q11 and raises it on the base of Q13. The result is that Q13 is turned on and Q11 is turned off, which causes a decrease in V_{out} . The negative transient causes a current to flow in the resistor bridge, which reduces the voltage on $V_{in}(-)$. The negative transient on $V_{in}(-)$ is inverted in the input stage and appears as a positive transient at the intermediate amplifier stage, after which it is once again inverted and amplified. The amplified component is added to the original transient (the sharp spike in Fig. 3) and appears as a tail on the rising portion of transient. Thus, the observed SET consists of a fast component from the original charge injected in Q9, followed by a slower component due to the feedback mechanism.

Exposure to ionizing radiation reduces both transistor gain and transistor drive. The reduction in Q9's gain produces a smaller initial transient and the reduced drive in the current sources (Q15, Q16, and Q19) results in slower recharging of the decoupling capacitor. TID tends to make it harder to turn transistor Q20 on, which suppresses the feedback component. The result is a small and narrow SET, as is seen in Fig. 3.

SETs originating on Q20

Q20 is located in the differential input section of the LM124 and, as a result, the SETs are expected to behave differently. Charge injection into Q20 turns the transistor on and produces a positive pulse with a fast rise time that charges the capacitor. The pulse is amplified and inverted in the intermediate amplifier, resulting in a negative pulse appearing at the base of Q11 and Q13. As was the case for Q9, the pulse momentarily turns on Q11 and turns off Q13, producing a negative pulse on the output. That negative component is fed back to the input where it adds a slower component to the original SET. In the meantime, the capacitor is discharged by the 6 μA current supplied by Q15 causing the transient to decrease. In contrast to situation for Q9, the initial pulse was amplified before it reached the output.

Following irradiation, the drive of transistor Q15 is significantly reduced and the feedback is suppressed by the radiation induced changes to Q20. The result is that the initial transient has a longer tail that persists on a time scale commensurate with the time it takes to discharge the capacitor. The fact that the tail of the SET in the irradiated device in the VF configuration is shorter than in the other two configurations is due to the much lower resistance in the feedback loop. The fact that the SET is so much longer for Q20 than for Q9 is due to the much smaller current source for Q20 (6 μA) than for Q9 (100 μA).

SETs originating on R1

Injecting charge into R1 momentarily increases its conductivity, which gives rise to a negative voltage transient on the base of Q9. That negative transient is amplified to saturation by the high gain of Q9, producing a positive transient on Q9's collector. The positive transient turns Q11 off and Q13 on, producing a positive transient on the output. The positive transient is fed back to the input and adds to the original transient. Equilibrium conditions are restored after charge injection by current supplied by the 100 μA current source, which rapidly recharges the capacitor, and the voltage on the output returns to its DC value. The addition of capacitance on the output leads to a voltage overshoot, producing a bipolar SET.

Following TID irradiation, the gain of Q9 is significantly reduced and the feedback is eliminated. SETs produced by laser light injected into R1 are greatly reduced in amplitude and width by the decrease in gain and the suppression of the feedback mechanism.

In summary, circuit analysis has confirmed that transients that originate in the differential input of the op-amp have longer pulses following irradiation than those originating in either the intermediate amplifier section or the output section due to the smaller current available for recharging the

capacitor in the case of the SETs in the input. Therefore, depending on which transients contribute when the op-amp is exposed to heavy ions, the SET rate could increase or decrease following TID degradation.

B. Heavy-Ion Results

During accelerator testing, the entire op-amp is exposed to heavy ions. SETs can originate in any transistor and the distribution of SET shapes and sizes reflects the sensitivities and cross-sections of the contributing transistors. Based on the pulsed laser results in the previous section, exposing the LM124 op-amps to TID radiation should change the distribution of SET shapes. Depending on which transistors are sensitive, some SETs will become narrower and others will become broader.

The significant differences in SET shapes among the three configurations are more evident in the data shown in Fig. 5 than in the data shown in Fig. 3, for which the results for only two transistors are presented. The point has been made previously, that SET shapes are dependent on configuration; the accelerator results presented here underscore this point.

A surprising result is that all the SETs for the pristine device in the IWG configuration exhibit a bipolar signature with the same basic shape, but with varying amplitudes. This suggests that one node dominates. The pulsed laser was used to identify the sensitive node as being R1, the transistor with floating base acting as a resistor. Fig. 6 shows the SETs obtained with pulsed laser light focused on R1 for different pulse energies. The SETs are essentially identical to those in Fig. 5 (upper left), confirming that R1 is the only sensitive node contributing to heavy-ion induced SETs for that configuration.

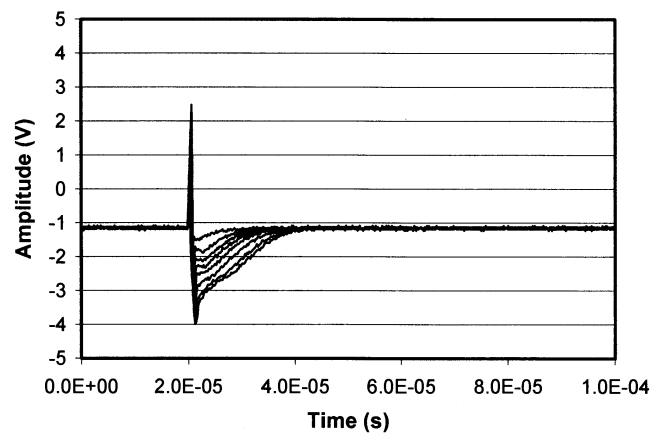

Fig. 6. SET captured when the light was focused on R1 and the pulse energy was varied. The output was loaded down with more capacitance than was the case for the data in Fig. 4.

The differences in the SET pulse shapes for R1 evident in the data of Figs. 4 and 5 (upper left) are worth addressing. The transients have a significantly larger negative component than that observed in the data of Fig. 4. The differences between the data sets arise from differences in the experimental setups. In the absence of parasitic capacitance,

the SET is a square wave with no bipolar component. With increasing parasitic capacitance, the negative component increases in amplitude due to overshoot. The data in Fig. 4 were collected with a single probe and a short coaxial cable that minimized parasitic capacitance. In contrast, because of the nature of the heavy-ion experiment, the data in Fig. 5 were obtained with two probes attached to the output and longer cables between the op-amp and the oscilloscope. By adding more parasitic capacitance to the output, the shapes of the SETs in the IWG configuration can be approximated. The variety of SET shapes observed for the other two configurations suggests that several transistors are SET sensitive for NIWG and VF configurations.

The differences in transient shapes between the different configurations provide a good example of why it is important to test in the same configuration as the intended application. The positive components of the bipolar SETs in the IWG configuration are much narrower than the positive transients in the other two configurations. For example, the positive components in the IWG configuration have widths on the order of 1 μs , whereas those in the VF are on the order of 30 μs . Therefore, to qualify the LM124 included in a system in which only positive SETs will ultimately be latched, one cannot use the data for the IWG configuration if the intended application is either the NIWG or the VG.

TID-induced degradation of transistor characteristics depends, in part, on the electrical bias. Therefore, to accentuate the effects of TID on SET shapes, we irradiated the devices with bias applied in the same configuration in which they were to be operated rather than with all inputs grounded and all outputs floating. For example, biases on transistors (Q11 and Q13), that form part of the “push-pull” output, are different in the NIWG and IWG configurations, for which V_{out} is 1.3 V and -1.43 V, respectively.

C. Significance for Error Rate Determination

The data in Fig. 5 show two significant changes in SET shapes following irradiation; the replacement of bipolar SETs with unipolar SETs (positive and negative) for the IWG configuration and the apparent temporal broadening of the SETs in all configurations. The pulsed-laser data in Fig. 4 reveal that TID causes significant reductions in amplitudes and widths of the SETs originating in R1. Therefore, if we assume that the bipolar SETs obtained with heavy ions in the IWG configuration originate primarily in R1 and that following irradiation they are greatly reduced in size, then the SETs in the irradiated part must originate in other transistors that have become more sensitive with dose.

It has become standard practice to display SETs in a less cluttered format than shown in Fig. 5 by plotting their amplitudes as a function of their widths (FWHM) [7]. Fig. 7 contains plots of amplitude versus width for the pristine and irradiated devices in the NIWG configuration and for ions with a LET of 2.8 $\text{MeV}\cdot\text{cm}^2/\text{mg}$. The plots illustrate clearly how total dose modifies SET shapes. In particular, the maximum

SETs have amplitudes greater than 2 V in the pristine device but less than 1 V in the irradiated device, and there is a general increase in width by a factor of approximately two.

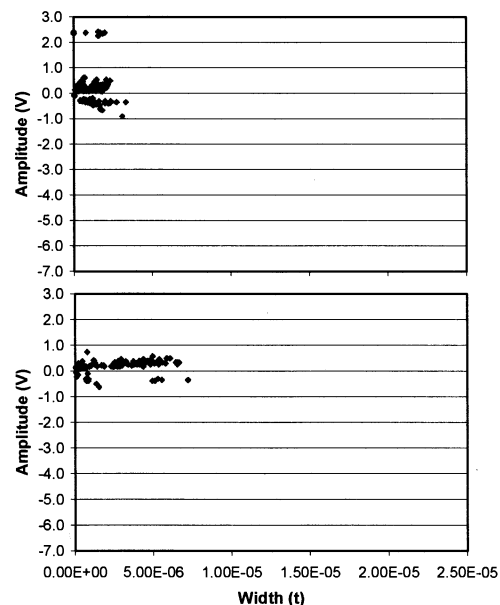

Fig. 7. Amplitude versus width for SETs in the pristine part (top) and the irradiated part (bottom) in the NIWG configuration for ions with LET = 2.8 $\text{MeV}\cdot\text{cm}^2/\text{mg}$.

Fig. 8 shows results for SETs in the NIWG configuration for LET of 54.8 $\text{MeV}\cdot\text{cm}^2/\text{mg}$. From the distribution of points in both graphs it is clear that the maximum amplitudes are the rail voltages, and there appears to be little difference between the two configurations regarding amplitudes. What TID does affect, however, are the SET widths, with the widths being wider in the irradiated device. For both LETs it appears that the points for the irradiated device are “stretched” along the time axis by a factor of approximately two compared to the pristine device.

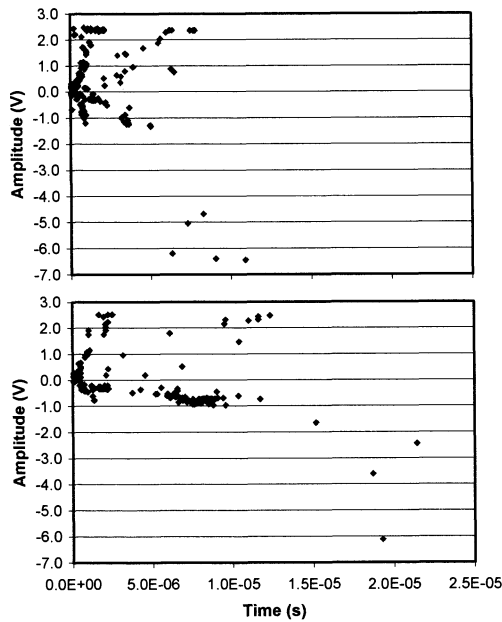

Fig. 8. Plots of amplitude versus width for the SETs in the NIWG at an LET of 54.8 MeV.cm²/mg.

The importance of this data can be illustrated in a simple example by considering a hypothetical subsystem. Fig. 9 shows the LM124 connected to a comparator (LM139). An input of 0.1 V for the LM124 produces an output of 1.1 V which is connected to the positive input of the LM139. The output of the LM139 is “high” as long as $V_{in}(+)$ is greater than 0.9 V. A filter is placed between the LM124 and the LM139 to eliminate all SETs shorter than 5 μ s. With a reference voltage of 0.9 V applied to $V_{in}(-)$ the DC level of 1.1 V applied to $V_{in}(+)$, SETs in the LM124 with amplitudes more negative than -0.2 V will cause the output of the LM139 to toggle. Therefore, this system is sensitive to SETs originating in the LM124 that are more negative than -0.2V and broader than 5 μ s.

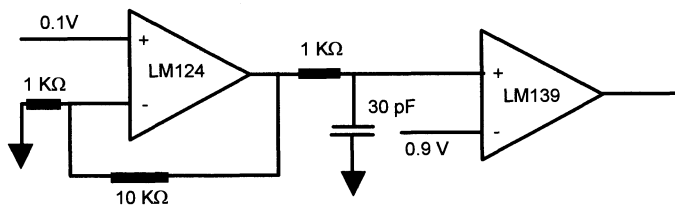

Fig. 9. Application for which negative SETs with amplitudes greater than -0.2 V and longer than 5 ms

How TID affects the SET rate can be assessed by referring to Petersen’s “Figure of Merit” approach, which uses data of SET cross-section as a function of ion LET [8]. The SET rate is proportional to the saturated cross-section and inversely proportional to the square if the LET threshold (defined as the LET value where the cross-section is 25% of the saturated value.) For calculating the cross-section for this application, only those points that meet the above criteria (< -0.2V and > 5 μ s) for each LET are counted.

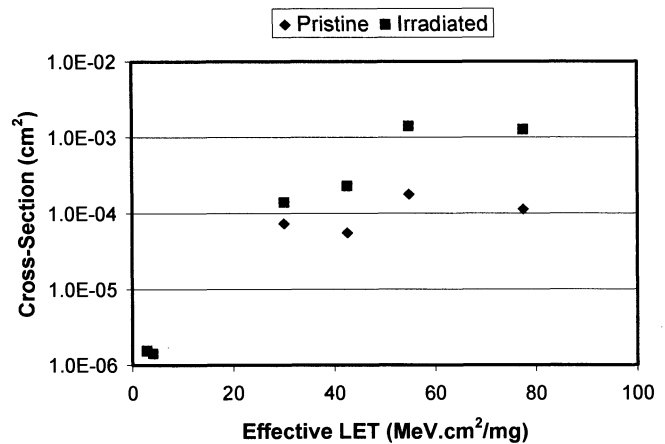

Fig. 10. Plot of SET cross-section as a function of effective LET for the NIWG configuration. Only SETs with amplitudes more negative than -0.2 V and longer than 5 μ s were counted in the calculation of the cross-section.

Fig. 10 shows plots of SET cross-section as a function of ion effective LET for the pristine and irradiated devices. The figure shows that, following irradiation, the saturated cross-section increases by roughly an order of magnitude and the threshold LET is reduced. No SETs met the criteria for the two lowest LETs. If the shift in the SET threshold is ignored, the SET rate increases by at least an order of magnitude in the irradiated part as compared to the pristine part.

The fact that the SET distortion is related to the TID-induced changes in electrical parameters means that, in a radiation-hardened device, the SETs should not be distorted. This was confirmed by exposing an RM124, the radiation-hardened version of the LM124, to a total dose of 100 krad(Si). Fig. 11 compares the SETs obtained for transistor Q9 in the IWG configuration using pulsed laser light. It is evident that the changes following irradiation are negligible. As a result, any changes observed in the SET rate for the RM139 during the course of a mission should reflect changes in the environment, and not in the device itself.

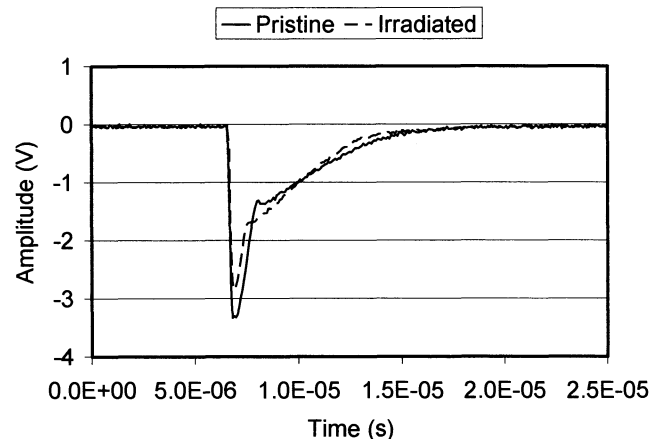

Fig. 11. SETs generated with pulsed laser light focused on transistor Q9 in the radiation-hardened RM124 operational amplifier. The device was in the IWG configuration.

Clearly this effect will be the greatest in linear bipolar devices that are not radiation-hardened. Therefore, testing for both TID and SET effects will have to be done if a design engineer decides to use a non-radiation hardened linear bipolar device for a particular space mission.

VI. CONCLUSION

The results presented in this paper clearly show that SETs originating in an operation amplifier have shapes that depend on the operating configuration. Furthermore, following irradiation, the SETs are distorted by TID such that some become wider and others become narrower. The physical locations of the SETs can be established with the aid of a pulsed laser microprobe. That information can then be used to explain the effects by noting that the recovery depends on the current drive of the current sources used to recharge the decoupling capacitor. Finally, these results illustrate the complexity of the TID effect on the generation of single-event transients in linear devices. The results reveal that the SET error rate associated with a linear part can either *decrease* or *increase* following TID exposure. A simple example was developed to illustrate a case in which the SET error rate increases by an order of magnitude. These results reveal the necessity of considering the TID dependence of linear devices, a result that may have significant hardness assurance implications.

REFERENCES

- [1] S. Buchner and D. McMorrow, "Single-Event Transients in Bipolar Integrated Circuits," IEEE Trans. Nucl. Sci. NS53, pp. 3079-3102, December 2006.
- [2] C. Poivey, J. L. Barth, J. McCabe and K. A LaBel, "A Space Weather Event on the Microwave Anisotropy Probe (MAP)," Presented at RADECS2002 workshop, September 2002.
- [3] S. Buchner, D. McMorrow and M. Maher, Characterizing Single-Event Transients in a Voltage Comparator (LM119) Presented at HEART, San Antonio, TX. March 2001.
- [4] M. Bernard, L. Dusseau, S. Buchner, D. McMorrow, R. Ecoffet, J. Boch, J.-R. Vaile, R. Schrimpf and K. LaBel, "Impact of TID Effect on Analog SET Sensitivity of Linear Bipolar Integrated Circuits," IEEE Trans. Nucl. Sci., (Submitted for publication.
- [5] S. Buchner, D. McMorrow, C. Poivey, J. W. Howard, R. L. Pease, M. Savage, L. W. Massengill, and Y. Boulghassoul, "Comparison of single event transients in an operational amplifier (LM124) by pulsed laser light and a broad beam of heavy ions," IEEE Trans. Nucl. Sci., vol. 51, no. 5, pp. 2776-2781, Oct. 2004.
- [6] A. L. Sternberg, L. W. Massengill, S. Buchner, R. L. Pease, Y. Boulghassoul, M. Savage, D. McMorrow, and R. A. Weller, "The role of parasitic elements in the single-event transient response of linear circuits," IEEE Trans. Nucl. Sci., vol. 49, no. 6, pp.3115-3120 Dec. 2002.
- [7] P. Adell, R. D. Schrimpf, H. J. Barnaby, R. Marec, C. Chatry, P. Calvel, C. Barillot, and O. Mion, "Analysis of single event transients in analog circuits," IEEE. Trans. Nucl. Sci., vol. 47, no. 6, pp. 2616-2623, Dec. 2000.
- [8] E. L. Petersen, J. B. Langworthy, and S. E. Diehl, "Suggested Single Event Figure of Merit," IEEE Trans. Nucl. Sci., vol. 30, pp. 4533-4539, Dec. 1983.