

08ICES-0296

Sensitivity of Hollow Fiber Spacesuit Water Membrane Evaporator Systems to Potable Water Constituents, Contaminants and Air Bubbles

Grant C. Bue¹, Luis A. Trevino¹, Sharon Fritts², Gus Tsioulos³

¹NASA Johnson Space Center, Houston TX

²ESCG-Jacobs-Svedrup, Houston TX

³Wyle Laboratories, Houston TX

Copyright © SAE International

ABSTRACT

The Spacesuit Water Membrane Evaporator (SWME) is the baseline heat rejection technology selected for development for the Constellation lunar suit. The first SWME prototype, designed, built, and tested at Johnson Space Center in 1999 used a Teflon hydrophobic porous membrane sheet shaped into an annulus to provide cooling to the coolant loop through water evaporation to the vacuum of space. This present study describes the test methodology and planning and compares the test performance of three commercially available hollow fiber materials as alternatives to the sheet membrane prototype for SWME, in particular, a porous hydrophobic polypropylene, and two variants that employ ion exchange through non-porous hydrophilic modified Nafion. Contamination tests will be performed to probe for sensitivities of the candidate SWME elements to ordinary constituents that are expected to be found in the potable water provided by the vehicle, the target feedwater source. Some of the impurities in potable water are volatile, such as the organics, while others, such as the metals and inorganic ions are non-volatile. The non-volatile constituents will concentrate in the SWME as evaporated water from the loop is replaced by the feedwater. At some point in the SWME mission lifecycle as the concentrations of the non-volatiles increase, the solubility limits of one or more of the constituents may be reached. The resulting presence of precipitate in the coolant water may begin to plug pores and tube channels and affect the SWME performance. Sensitivity to macro-

particles, lunar dust simulant, and air bubbles will also be investigated.

INTRODUCTION

Waste heat rejection for the Apollo and Shuttle Spacesuits has been previously accomplished through a sublimator. The Spacesuit Water Membrane Evaporator (SWME) is being developed to perform the sublimator function for advanced spacesuits. Heat rejection is a necessity for spacesuits in every EVA to cool the suited subject during operations, and to cool the electronic components in the PLSS. The SWME is a concept in which a permeable or porous membrane is used to reject water vapor and heat to the vacuum of space. As water evaporates through these membranes into a vacuum, heat is removed, cooling the water in the line.

The SWME program takes advantage of recent advances in micropore membrane technology to provide a robust heat rejection device that is much less sensitive to contamination than the sublimator. The SWME will also simplify the spacesuit cooling system design by using the heat transport loop as feedwater, eliminating the need for a separate feedwater system. The SWME design was initially conceived, designed, and verified with a prototypic test article which was tested in a vacuum chamber at Johnson Space Center during July 1999 [1]. A cross section of that design is shown in Figure 1.

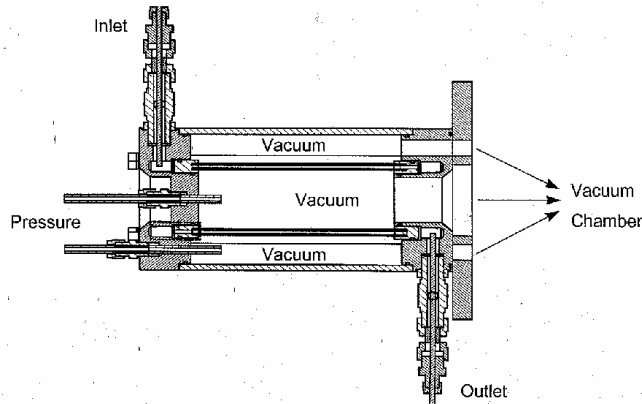

Figure 1. Original SWME Test Prototype

The results of the tests are the following:

-SWME can be used to reject heat (approx 1600 Btu/hr for this unit) of the cooling water circulating in the Spacesuit PLSS;

-SWME backpressure can be used to control SWME heat rejection rate;

-the SWME membrane will freeze if SWME is exposed to vacuum with water not circulating but stalled in it;

-SWME size can be changed per cooling requirements; and SWME design needs to be improved for better installation of the membrane, as well as development of the SWME core.

-Although the SWME concept was proven to be feasible in these tests, several development hurdles still exist.

Along with improvements needed in the original sheet membrane SWME concept, also called SaM SWME, other membrane technologies are being pursued that may yield lower mass and volume, and more reliable operations. Test articles for the tests described in this paper are to be obtained from possible technologies described in the literature and summarized in a subsequent section.

SPACESUIT WATER MEMBRANE EVAPORATOR REQUIREMENTS

In order to optimize the SWME for insertion into the Constellation program, a new effort has

been begun in 2007 to design and test various SWME concepts. Regardless of the SWME configuration selected, development requirements have been specified for the Spacesuit Water Membrane Evaporator (SWME) Subsystem. The SWME requirements are taken from JSC-65684, EVA Technology Development COTS Fiber SWME Element Test Requirements/Test Plan, Oct 2007, and are summarized as follows:

Functional Requirements for SWME

The following are overall functional requirements for the suit thermal subsystem and for the SWME derived from Constellation suit element requirements:

1. Provide cooling and thermal regulation to suited EVA crewmember in vacuum (micro-g), lunar, and Mars* environments for up to 8 hours continuous.
2. Provide cooling and thermal regulation to spacesuit components during EVA in vacuum (micro-g), lunar, and Mars environments for up to 8 hours continuous. For development design purposes, focus shall be on the lunar design with protection for key design features for the Mars capability. Full Mars functional capability is to be demonstrated in future developments.
3. Incorporate evaporative capability of water to satisfy the cooling requirements in (1) and (2).

Specific SWME Requirements

1. Maximum heat load of 810 watts (2754 Btu/hr) at 10 degC (50 degF) water outlet.
2. Minimum heat load of 81 watts (276 Btu/hr) at 24 degC (75 degF) water outlet.
3. Capability to turn off SWME heat rejection (0 watts) at any time .

The above system heat loads include a design metabolic rate, electronics/motors heat load, and hot environment suit heat leak. The total heat

load, however, allows for latent heat removed by the RCA thus reducing the load on the SWME. Adding some margin brings the recommended value up to 2750 Btu/hr. This maximum recommended heat load must be obtainable at the lowest water outlet temperature of the SWME, 50 degF, to provide adequate thermal comfort and cooling at high metabolic loads. The minimum heat load is the lowest expected metabolic load from the crewmember that would need to be sustained at the expected thermal comfort temperature of 75 degF.

4. Water Flowrate into SWME: 91kg/hr
(200lbm/hr)

The specified flowrate is derived from Shuttle LCG experience that has shown adequate heat transfer coefficient of the LCG at 200 lbm/hr water flowrate, with little improvement at 240 lb/hr, the current Shuttle water flow. Lowering the water flowrate to 200 lbm/hr reduces the pump power required, in turn reducing weight and volume of the PLSS.

5. Water Pressure into SWME:
30 - 69 kPa [4.2 - 10 psid] in Vacuum
EVA environment.

The selection of the operating pressure is based on the use of the maximum suit pressure operating pressure (DCS mode) as the driving pressure for the transport loop. The minimum pressure is based on suit operating pressure. The supporting trade study rationale is documented in JSC-65443, CSSE PLSS Schematic Study and a detailed description of the reference architecture schematic is documented in JSC-65563, PLSS Baseline Schematics and Internal Interfaces.

6. SWME Useful Life: 100 EVA's, 8 hours each

The rationale for PLSS life for Constellation is 100 EVAs, based on a 180 day outpost mission with an EVA every other day, and a 10 EVA margin added for contingencies.

7. SWME Water Quality

The PLSS shall accept potable water from Vehicle, with and without silver biocide, as specified in the Potable Water Table (TBD-CSSE-136).

This is derived from the need to satisfy a single water specification provided by the Constellation Program. Therefore, the PLSS will be capable of accepting that water without excessive processing.

8. Servicing and Maintenance

As a minimum, replacement of the SWME within the PLSS shall be carried out at the lunar lander, the lunar habitat, and in zero and micro-g while in the lunar transport vehicle.

9. Goals for SWME Mass and Volume

Volume:	< 125 in ³
Mass:	<3.5 lbm

The above are current PLSS packaging system goals.

10. PLSS and SWME Packaging Scheme

The NASA-JSC Flex PLSS packaging concept is to be used as a baseline for the PLSS and SWME packaging scheme.

11. SWME Standby and StartUp Capability

After unpowered modes, the SWME shall be capable of startup and provide any of its required heat loads when the initial SWME water inlet is between 35 F to 100 F (1.7degC to 38 degC).

This requirement rationale is derived from the need for the SWME to be maintained at adequate temperatures during unpowered modes so that it is capable of startup after being unpowered. The PLSS systems must maintain these required startup temperatures. The lower temperature limit is required to keep the water loop from freezing and the upper temperature limit is an upper limit for crew comfort with some margin for inward heat leak.

12. SWME External Operating Environments

Deep Space Vacuum , $<10^{-12}$ torr

Lunar Polar and Equatorial [6],

10^{-12} torr

Mars, 4.4-11.3 torr [7], CO₂

TEST OBJECTIVES

The overall test objective is for the COTS units for this series of tests to be procured and tested as scaled down versions of the full size SWME unit. As such the requirements for the full size SWME are adapted to each candidate technology COTS unit.

The primary test objective for the hollow fiber SWME tests is to evaluate the feasibility of COTS hollow fiber elements as alternatives to sheet membrane evaporative elements in SWME application. Secondary test objectives are:

1. Determine sensitivity and performance degradation of COTS elements to contaminants found in potable water over the required SWME life cycle.
2. Determine thermal performance of COTS elements as a function of water inlet pressure, exit vapor back pressure, air bubbles in the inlet water, and effect of lunar dust in the SWME water inlet.

Detailed descriptions of the tests are presented in a subsequent section.

HOLLOW FIBER TYPES & TEST CANDIDATES

Literature Survey of Potential SWME Membranes

Along with improvements needed in the original sheet membrane SWME concept, also called SaM SWME, there are other membrane technologies from the literature that may yield lower mass and volume, and more reliable operations. Test articles for the tests described in this report were obtained from the following possible technologies described in the literature:

Membranes for Industrial Separations [2]. Breakthroughs in development of membrane materials have led to commercialization of membrane separation systems for waste treatment, desalination, gas-mixture separations, and other high-volume applications. Membranes separate fluid components on the basis of differences in permeation rates through the membrane. The semi permeable membrane rejects dissolved salts but allows water to pass through. Two membrane forms dominate industrial fluids separation: hollow fibers and spiral-wound sheets. Spiral-wound units tend to have higher permeability but lower packaging density, and with hollow fibers the converse is true.

Membrane Separation Processes

A synthetic membrane is an interphase which separates two phases and restricts the transport of various chemical species [3]. through the membrane interphase. Microfiltration, ultrafiltration, reverse osmosis, dialysis, and electrodialysis have been accepted as very useful tools for the separation of molecular mixtures. These processes are now widely used to produce portable water from sea and brackish water sources, to recover valuable products from industrial effluents, or to perform various concentration, purification and fractionation tasks in the chemical, food and drug industries.

Hollow Fiber Membrane Air Dryer

Monsanto developed the first commercial polymeric membrane separator in the form of a hollow fiber in 1979 [2]. because it is the most effective way to pack a large amount of membrane area into a given vessel and it withstands high pressures. A hollow fiber dryer consists of a bundle of fibers “plotted” at both ends in an epoxy. This bundle is inserted and sealed into a shell. The unique advantages of the hollow fiber unit are the following: it has no moving parts therefore no maintenance; there is no desiccant to replace and no shuttle valves that can stick or hang up; and there are no electricals that can corrode or fail.

Humidity Control via Membrane Separation (EMU Application)

NASA membrane technology to control humidity control tested a hollow fiber dehumidification module, in which a 90 day test was performed

and indicated that a long term, reliable performance is feasible with this technology [4]. The program was able to develop novel hollow-fiber dehumidification membranes that efficiently remove water vapor from air under the range of conditions expected to be present in the EMU. The two key advantages of using hollow-fiber membrane modules are: their high packaging density, and their low permeate-pressure drop, which increases transport of water vapor across the membrane.

Principles of Permeation and Separation

In most membrane processes, mass transport through a nonporous polymer membrane is caused by a chemical potential gradient or by the difference in the free energy of the permeate between membrane upstream and downstream interfaces [5]. For many applications, membrane permeability is too low and the separation process becomes feasible only when the membrane resistance to transport reaches a certain minimum. This can be attained for a given permeability coefficient value by reducing the thickness of the permselective barrier, which for many materials is below the level allowable for mechanical self-support. The solution to this problem was found in the structures and morphologies of anisotropic membranes that support permselective barriers.

Hollow Fiber Element COTS Test Candidates

The first prototype of the SWME used a Teflon hydrophobic porous membrane that allowed only vapor to escape [1]. The membrane was shaped into an annulus to allow for a high amount of surface area for the water to pass by without restricting the flow.

Other geometries and materials may use space and weight more efficiently. There are a variety of COTS, hollow fiber tubular units. The types of membrane materials used to make the hollow fibers fall into two categories: hydrophobic and hydrophilic ion exchange. Figure 2 is a schematic of a tubular hollow fiber, or HoFi unit. The units are operated in a vertical position. For this application a vacuum is pulled on the shell side, rather than a dry sweep gas.

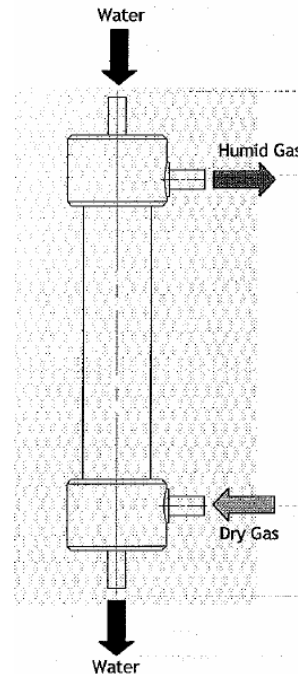

Figure 2: Schematic of a HoFi unit

Two hydrophobic test articles were identified. The first is a degasser made by Membrana [8]. They contain polypropylene hollow fibers with a porosity of 40%. These HoFi units are primarily used to degas water, but they also are used as humidifiers, by evaporation of water through the porous polypropylene fiber. A unit with 7400 hollow fibers was identified for testing, the 1.7 inch X 5.5 inch MiniModule. The outer housing is polycarbonate.

The second article is composed of polysulfone fibers, and is manufactured by EnerFuel [9, 10]. This unit has a maximum differential pressure between the tubes and the shell of 15 psid. They have one COTS unit, the EFH-100WA, and it contains about 15,000 tubes. One of these units has been tested as a humidifier at NASA Ames Research Center, with use of a sweep gas as shown in Figure 1, and liquid water transported through the membrane when the water pressure at the tube inlet was too high [11]. The outer housing is polycarbonate, so the water on the shell side was easy to see.

The ion exchange membrane units are composed of a Teflon backbone with sulfonic acid ion exchange groups. The sulfonic acid groups permeate water vapor through the membrane to provide the cooling. The first

COTS unit is manufactured by Perma Pure, and it uses Nafion membranes, that are manufactured by DuPont [13]. A test unit with 240 tubes was acquired already. The concern with the ion exchange membrane units is that cationic impurities, such as sodium, potassium, calcium, magnesium and nickel, will replace the hydrogen atoms attached to the sulfonic acid groups, thereby inhibiting water transport [14, 15].

The second ion exchange membrane test article is the SunSep SFC series hollow fiber membrane module [16]. It uses the Asahi Glass Flemion membrane, that has the same polymer structure as Nafion, but the length of the side chain and the concentration of the ion exchange group is different. Side chain length has been shown to affect water transport properties, so the performance of the SunSep should differ from the performance of the Permapure system, but the same concerns relating to ion exchange of cationic impurities still applies. The test unit is TBD, but it should contain approximately the same number of tubes and the same membrane area as the Permapure unit, for ease of comparison. It should be noted that SunSep recommends supplying the water to the shell side of the unit, but the unit should initially be tested with water feed to the tube side for comparison.

Rasic's Rainmaker uses a hydrophilic ion exchange membrane [17, 18]. It is a modified form of Nafion that allows for higher temperature operation and higher differential pressures. The Nafion is not cast from a DMSO solution as suggested by Nafion, but from an alcohol solution, so there should be less organic residual on the Rainmaker unit. The membrane tubes are mechanically sealed in Teflon, so there should be less leakage. Again, a reduction of performance over time is expected because of the ion exchange of the impurities in the Nafion.

The Rainmaker units are potted with the tubes spaced further apart [18] than the Perma Pure units, so the shell mass transfer limitations that are observed with the Perma Pure units should not be as prominent in the Rainmaker units. A Perma Pure unit with 7000 tubes was tested at NASA Ames Research Center, in a different configuration with humid air in the tubes, and a dry air sweep gas in the shell, and its

performance was only 15-35% of the performance of the units with 1 or 50 tubes [19].

Scale-up issues will be encountered in the large tube bundles, so units with a small number of tubes that have more uniform spacing should be used for performance determination.

Table 1. Candidate HoFi Test Units

Manufacturer	Membrana	EnerFuel	PermaPure	SunSep	Rasic Rainmaker
Model	1.7 in X 5.5 in MiniModule	EFH-100WA	FC-124-240-5	TBD	TBD
Approx Diameter	5 cm	7 cm	6 cm	TBD	TBD
Approx Length	18 cm	32 cm	21 cm	TBD	TBD
Active Material	polypropylene	polysulfone	Nafion	Flemion	Nafion (Modified)
Active Area	0.58 m ²	TBD	0.001024 m ² [Error! Reference source not found.]	TBD	TBD
Number of Tubes	7400	15,000	240	TBD	~40
Minimum Temp.	TBD	TBD	TBD	TBD	TBD
Maximum Temp.	~45°C TBD	80°C	TBD	~80°C TBD	80°C
Maximum Differential Pressure	TBD	15 psid	5 psid	TBD	TBD

The Membrana and EnerFuel test units will need to be monitored to ensure that the liquid water is not being forced through the pores, without providing the benefit of evaporative cooling. The Perma Pure, SunSep and Rasic may lose performance due to the quality of the potable water. The Rasic Rainmaker units are more custom built, with better flow dynamics and materials of construction, and probably much more costly. They might be a better candidate for a performance test after the Perma Pure unit is able to demonstrate good performance in the contamination tests.

TEST APPROACH AND METHODOLOGY

Contamination Test Approach

The contamination test is designed to probe for sensitivities of the candidate HoFi elements to ordinary constituents that are expected to be found in the potable water source. For this the highest measured levels of each impurity found in ISS potable water for Increments 12 and 13 are selected as the baseline water quality, to be

supplied to each of the feedwater tanks (see Table 2). These ordinary impurities are tested separately from macro-particles, lunar dust simulants, and air bubbles that will be investigated in the performance tests, described in a subsequent section. Some of the ordinary potable water impurities are volatile, such as the organics, while others, such as the metals and

Table 2. Baseline Impurities List to Study in Contamination Tests

	Units of Measurement	CxP Maximum Contaminant Level (MCL) [20]	CxP MCL Source [20]	Baseline Water Quality: Average in SRV-K Samples** [21]	After 25 cycles, assuming 50% evaporation rate/cycle***
Conductivity	µS/cm			90	1170
pH	pH units	4.5-9.0		7.1	
Turbidity	NTU	1		0.3	
Total Dissolved Solids	mg/L			41	533
Iodine (LCV)	mg/L	0.2	SFR A13-30	<0.05	0.65
Anions (IC/ISE)					
Chloride	mg/L	250		2	26
Sulfate	mg/L	250		5	65
Cations (IC)					
Ammonia	mg/L	1	SWEG	0.02	0.26
Lithium	mg/L			0.01	0.13
Metals (ICP/MS)					
Calcium	mg/L			12	156
Magnesium	mg/L			2	26
Potassium	mg/L	340		1	13
Sodium	mg/L			1	13
Aluminum	mg/L			0.01	0.13
Barium	mg/L	10	SWEG	0.03	0.39
Copper	mg/L	1		0.02	0.26
Iron	mg/L	0.3	SWEG	0.02	0.26
Manganese	mg/L	0.3	SWEG	0.01	0.13
Nickel	mg/L	0.3	SWEG	0.05	0.65
Silver (total)	mg/L	0.4	SWEG	0.5****	6.5
Zinc	mg/L	2	SWEG	0.1	1.3
Carbon					
TIC	mg/L			9	117
TOC	mg/L	3	SWEG	2	26
Organics					
Formate (as formic acid)*	mg/L	2500	SWEG	7 [22]	91
Tetrahydrofuran	mg/L			0.04	0.52
Benzothiazole	mg/L			0.01	0.13

*Formate was found in 2002 SRV-K Samples when water was provided to the SVO-ZV from ISS, so it is added here [22].

**Proposed impurity levels are average values in Expedition 12 and 13 samples [21].

***Actual concentration equivalents for 25 EVAs will be determined by water quality testing.

****Expected silver concentration for biocide on CEV, actual ISS level 0.03

inorganic ions are non-volatile. The non-volatile constituents are expected to concentrate in the SWME as evaporated water from the loop is replaced by the feedwater. At some point in the SWME mission lifecycle as the concentrations of the non-volatiles increase, the solubility limits of one or more of the constituents may be reached. The resulting presence of precipitate in the coolant water may begin to plug pores and tube channels and affect the HoFi SWME performance. The different materials of the candidate HoFi elements might be differentially sensitive to the precipitate or to other constituents in the coolant.

To determine approximately when in the 100 EVA SWME duty cycle the candidate systems would begin to degrade, a series of trials will be conducted with progressive contamination to monitor performance and check for degradation at contamination levels predicted for 0 EVA's (baseline water quality), 25 EVA's, 50 EVA's, 75 EVA's and 100 EVA's. The first trial begins with the baseline water quality for the test loop and feedwater. Each candidate HoFi element will be tested for performance and degradation for 100 hours of operation. Then the water will be sampled at the sample port and assayed for the various contaminants. For each impurity assayed, the concentration will be determined according to the equation:

Equation 1: Impurity Concentration

$$x_{25EVA's} = x_o + (x_{100hrs} - x_o) \left(\frac{m_{H2O,25EVA's}}{m_{H2O,100hrs}} \right) \left(\frac{V_{loop,test}}{V_{loop,CSSE}} \right)$$

where $x_{25EVA's}$ is the concentration of an impurity extrapolated to 25 EVA's, x_o is the baseline concentration of the impurity, x_{100hrs} is the concentration of the impurity in the test loop after 100 hours of testing, $m_{H2O,25EVA's}$ is the total mass of water expected to be evaporated by SWME in 25 EVA's, $m_{H2O,100hrs}$ is the total mass of water evaporated by the HoFi element in 100 hours of testing (200 hours equal to 25 EVA's), $V_{loop,test}$ is the volume of the coolant loop in the test and $V_{loop,CSSE}$ is the volume of the coolant loop expected in the CSSE configuration 2. The second trial, the 25 EVA trial, begins by reconstituting the coolant test loop to that of the coolant loop of the CSSE after 25 EVA's. Performance and degradation will be monitored for another 100 hours of operation. This process will be repeated for the third trial (50 EVA's), fourth trial (75 EVA's) and the fifth trial (100 EVA's).

Performance Test Approach

Four test series will be conducted with the candidate HoFi elements exploring four fundamental performance issues.

The first series will test for performance at the extremes of the expected range of coolant loop

pressures, 4.3 psia and 15 psia for 50 hours each.

The second series will test for the potential for back pressure control by enclosing the candidate HoFi elements in a can that is fitted to allow the inlet and outlet water streams to pass but is otherwise open only on one end. This end is mated with a cap that has an orifice through which the water vapor must pass to the vacuum chamber. Several end caps with different orifice sizes will be tested. Each set of orifices will be tested against each candidate HoFi element for four hours.

The third series will test the candidates for vulnerability to air bubbles. Air bubbles, first 5 cc's, then 10 cc's, and finally 20 cc's will be injected into the sample port. After each aliquot is injected into coolant stream the performance of the HoFi elements will be monitored for four hours. Clear tubing segments will allow viewing of the inlet and outlet coolant streams for the presence of circulating bubbles.

The final series will investigate the effect of lunar dust simulant, and various sizes of plastic and/or metallic particles on the performance of the candidate HoFi elements. A TBD amount of lunar dust simulant will be injected into the sample port and the performance will be monitored for four hours if performance stabilizes or for longer if the performance continues to degrade. If a substantial degradation of any of the units are observed they will be replaced before proceeding to the particle tests. A TBD amount of particles of TBD size range will be introduced into the coolant stream through the sample port and as with the lunar simulant will be monitored for four hours if performance stabilizes or for longer if the performance continues to degrade.

Performance Test Instrumentation

The instrumentation is identical to the contamination tests (see sub-section 5.1.3) except for the back pressure tests. In the back pressure tests the internal can pressure is also measured. The instrumentation requirements for all tests will be detailed in sub-section 6.3.

TEST FACILITY SET-UP

Contamination Test Set-up

Once downselected, a number of hollow fiber (HoFi) technology candidates are expected to remain for contaminant testing. A schematic for these tests is presented in Figure 3. The “~” tilde symbol in the figure represents the other HoFi candidates between 1 and n that are not depicted. Each HoFi candidate is tested on an independent coolant loop, each with a pump, a heater cart, a feedwater tank and a sample port for removing coolant loop samples and adding contaminants. Each HoFi candidate technology is scaled down to about one third to one fifth of that of the SWME requirements, and hereafter will be termed candidate HoFi elements.

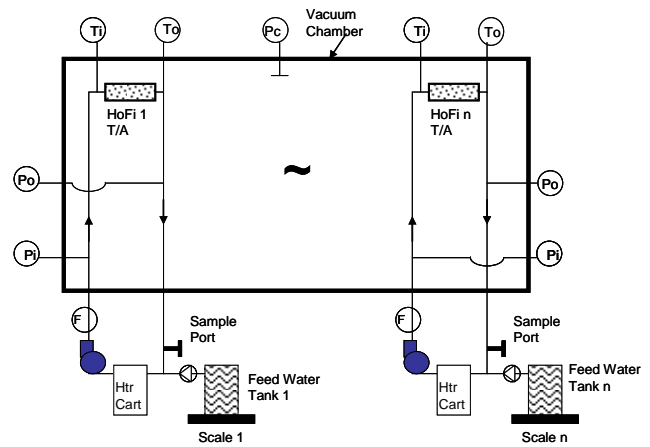

Figure 3. Hollow Fiber Contamination Test Set-Up

Contamination Test Instrumentation

For each HoFi candidate, thermistors or RTD's will be used to accurately measure the inlet and outlet water temperatures of the test article. A flowmeter in the water system will be used to measure system flowrate and a scale will be used on the accumulator tank to measure water loss. Water inlet and outlet pressure, and chamber pressure are also needed. The instrumentation requirements for all tests will be detailed in sub-section 6.3.

Performance Test Set-up

With exception of the back pressure tests (second series) the test set-up for the performance test is the same as for the contamination tests (see Figure 3) Each HoFi candidate is tested on an independent coolant loop, each with a pump, a heater cart, a

feedwater tank and a sample port for injecting bubble, dust or particles.

A schematic for the back pressure tests is presented in Figure 4). Each HoFi element is enclosed in a can with an end cap orifice plate which can be replaced with plates having a different orifice sizes.

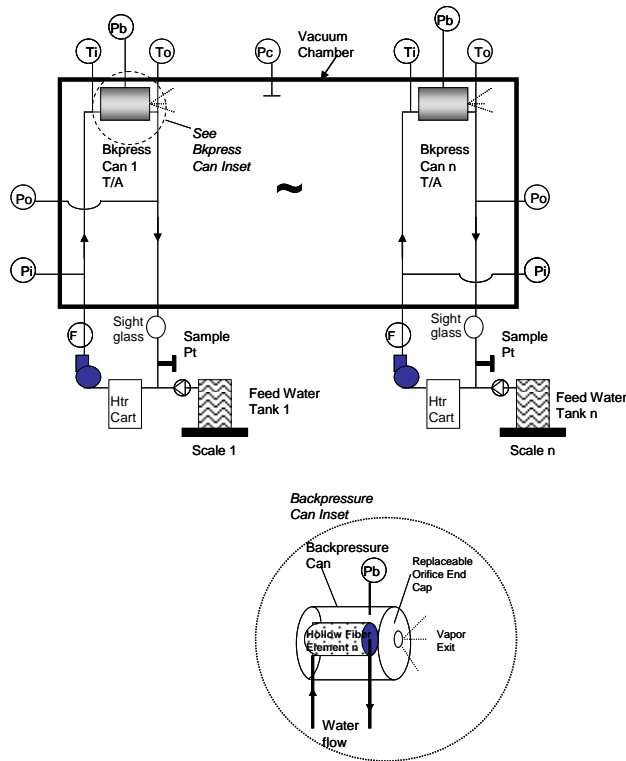

Figure 4. Hollow Fiber Back-Pressure Test Set-Up

Test Facility Requirements

Test facilities at NASA-JSC are to be used for these tests. Several facilities meet these requirements, including Chamber N in JSC Building 33, the Avionics Vacuum Chamber currently in Building 222 and the LTVC in the Building 7 Suit Lab.

The chamber will be maintained at its maximum sustainable vacuum conditions throughout the test. The chamber will provide a thermal environment ranging from 60°F to 80°F. The chamber environment will be controlled using LN2 cold shrouds (insulated from the chamber interior or cold traps to obtain a maximum

chamber pressure of 1 torr absolute and maximum evaporation load of 90 liters/second.

A data acquisition system will be used to monitor and record both facility and TA parameters, including water temperatures, water flowrate, water pressures, and feedwater usage.

TEST RESULTS SUMMARY

Test results are to be available for the final paper due in May 2008, pending test facility buildup and start of tests in March 2008.

CONCLUSIONS & FORWARD WORK

The Spacesuit Water Evaporator (SWME) is being developed to perform the thermal control function for advanced spacesuits to take advantage of recent advances in micropore membrane technology in providing a robust heat rejection device that is potentially less sensitive to contamination than the sublimator. Principles of a sheet membrane SWME design were demonstrated using a prototypic test article which was tested in a vacuum chamber at Johnson Space Center during July 1999 [1]. A hollow fiber membrane alternative to the sheet membrane SWME has been explored from commercial experience, and its use for spacesuit cooling is being explored with feasibility testing of commercial (COTS) hollow fiber elements as alternatives to sheet membrane evaporative elements.

Conclusions of the COTS hollow fiber tests and hollow fiber membrane feasibility in the SWME will be available for the final paper due in May 2008, pending test facility buildup and start of tests in March 2008.

REFERENCES

1. Ungar, E.K, and G. A Thomas, "Design and Testing of a Spacesuit Water Membrane Evaporator," Proceedings of the 2001 Nation Heat Transfer Conference, ASME, June 2001, Anaheim, CA.
2. Joseph Haggin, "New Generation of Membranes Developed for Industrial

- Separations," Chemical and Engineering News, June 6, 1988.
3. H. Strathmann, "Membrane Separation Processes," Journal of Membrane Science, 1981, p.121-189.
 4. Scott B. McCray, "Investigation of Humidity Control via Membrane Separation for Advanced Extravehicular Mobility Unit (EMU) Application," Final Report NAS9-17983.
 5. Israel Cabasso, "Membranes," Vol 9, State University of New York, ESF at Syracuse, p. 513-578, (1991).
 6. Neal, V., J. Shields, G. Carr, W. Pogue, H. Schmitt, A. Schulze, "Extravehicular Activity at a Lunar Base," NAS9 17779, 1988.
 7. Neal, V., J. Shields, G. Carr, W. Pogue, H. Schmitt, A. Schulze, "Extravehicular Activity in Mars Surface Exploration, Final Report NAS9 17779, 1989.
 8. 1.7X5.5 MiniModule Product Data Sheet, http://www.liquicel.com/uploads/documents/D86_1.7x5.5%20Mini%20Module_Rev13_7-074.pdf, Oct. 24, 2007.
 9. Communication with Ramesh Krishnaiyer, EnerFuel Inc., 10/22/07.
 10. EnerFuel Solid State Humidifier (EFH-100), <http://www.enerfuel.com/prod.shtml>, 10/10/2007.
 11. Communication with Bernadette Luna, NASA Ames Research Center, 10/24/2007.
 12. Communication with Matt Powers, Perma Pure LLC, 7-25-07.
 13. FC-Series Humidifier User Manual, Perma Pure LLC, Bulletin #207.
 14. Tap Water and the Ion Exchange Properties of Nafion, Perma Pure LLC, <http://www.permapure.com/TechNotes/Tap%20Water.htm>, 10/10/2007.
 15. Communication with Jeffrey L. Jones, DuPont USA, 10/22/2007.
 16. Communication with Takahiro Saito, AGC Engineering Co., Ltd., SUNSEP Group, 10/17/2007.
 17. Rainmaker Datasheet, Rasirc, http://www.rasirc.com/resources/datasheets/datasheet_RASIRC_RainMaker_Family.pdf, 10/22/2007.
 18. Communication with Jeffrey Spiegelman, President, Rasirc, 10/25,2007.
 19. Moate, J.R. M. D. LeVan, B. Luna, L. Mulloth, J. Hogan, and B. Webbon, "Nafion Multi-Tube Membrane Bundle for Use in Dehydration of Gas Streams," SIMA Telecon, August 16, 2007.
 20. Constellation Program Human-Systems Integration Requirements, CxP 70024, Revision A, Release Date: September 26, 2007.
 21. Straub, J.E., D.K. Plumlee, and J.R. Schultz, "Sampling and Chemical Analysis of Potable Water for ISS Expeditions 12 and 13," ICES Paper 2007-01-3214, Chicago, IL, 2007.
 22. Plumlee, D.K., P.D. Mudgett, and J.R. Schulz, "ISS Potable Water Sampling and Chemical Analysis: Expedition 4 & 5," ICES Paper 2003-01-2401, Vancouver, BC, Canada, 2003.

ABBREVIATIONS

COTS	Commercial Off The Shelf
DCS	Decompression Sickness
EVA	Extra-vehicular Activity
EMU	Extra-vehicular Mobility Unit
HoFi	Hollow Fiber
ISS	International Space Station
LCG	Liquid Cooling Garment
PLSS	Portable Life Support System
RCA	Recycling Amine
SWME	Spacesuit Water Membrane Evaporator

