

VV15FC-584

# Recent Plasma Observations Related to Magnetic Merging and the Low-Latitude Boundary Layer. Case Study by Polar , March 18,2006

M. Chandler  
L. Avanov  
P. Craven  
F. Mozer  
T.E. Moore

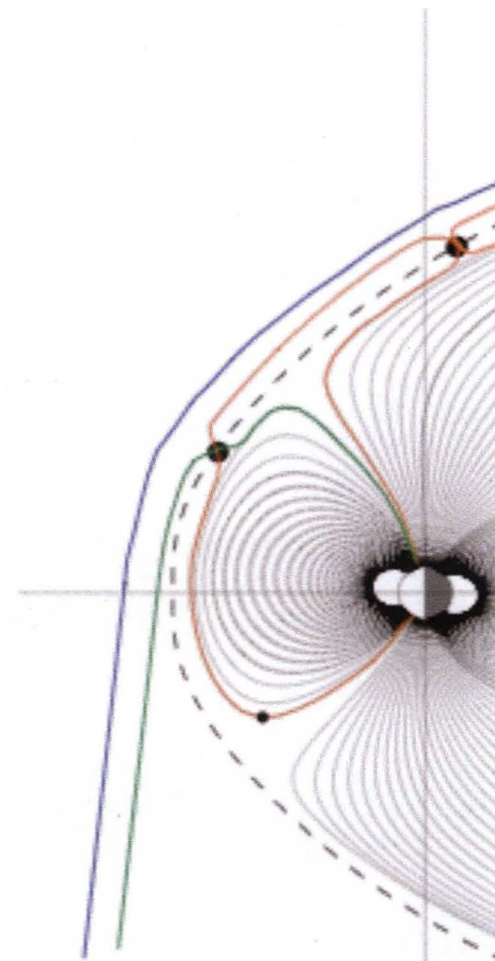

**Hypothesis:** High-latitude magnetic merging can occur on the same field line in both hemispheres.

**Consequences:** Field lines connected previously to the solar wind are “captured” by the terrestrial magnetic field and become closed “terrestrial” field lines containing magnetosheath plasma. Presents a possible mechanism for the formation of the LLBL and, the cold, dense plasma sheet during northward IMF conditions.

**Observations:** Le et al., 1996, Onsager et al., 2001. Recently, Cluster observations of bidirectional, heated electrons were used to infer the presence of magnetosheath plasma on dayside, closed field lines. (Lavraud et al., 2005)

# Abstract

We have begun an investigation of the nature of the low-latitude boundary layer in the mid-altitude cusp region using data from the Polar spacecraft. Magnetosheath-like plasma is frequently observed deep (in terms of distance from the magnetopause and in invariant latitude) in the magnetosphere. One such case, taken during a lull period of northward interplanetary magnetic field (IMF) on March 18, 2006, shows injected magnetosheath ions within the magnetosphere with velocity distributions resulting from two separate merging sites along the same field lines. Cold ionospheric ions were also observed counterstreaming along the field lines, evidence that these field lines were closed. Our results support the idea of double reconnection under northward IMF on the same group of field lines can provide a source for the LLBL. However, the flow direction of the accelerated magnetosheath ions antiparallel to the local magnetic field and given location of the spacecraft suggest that these two injection sites are located northward of the spacecraft position. Observed convection velocities of the magnetic field lines are inconsistent with those expected for double post-cusp reconnection in both hemispheres. These observations favor a scenario in which a group of newly closed field lines was created by a combination of high shear merging at high latitudes in the northern hemisphere and low shear merging at lower latitudes at the dayside magnetopause.



2006/03/18

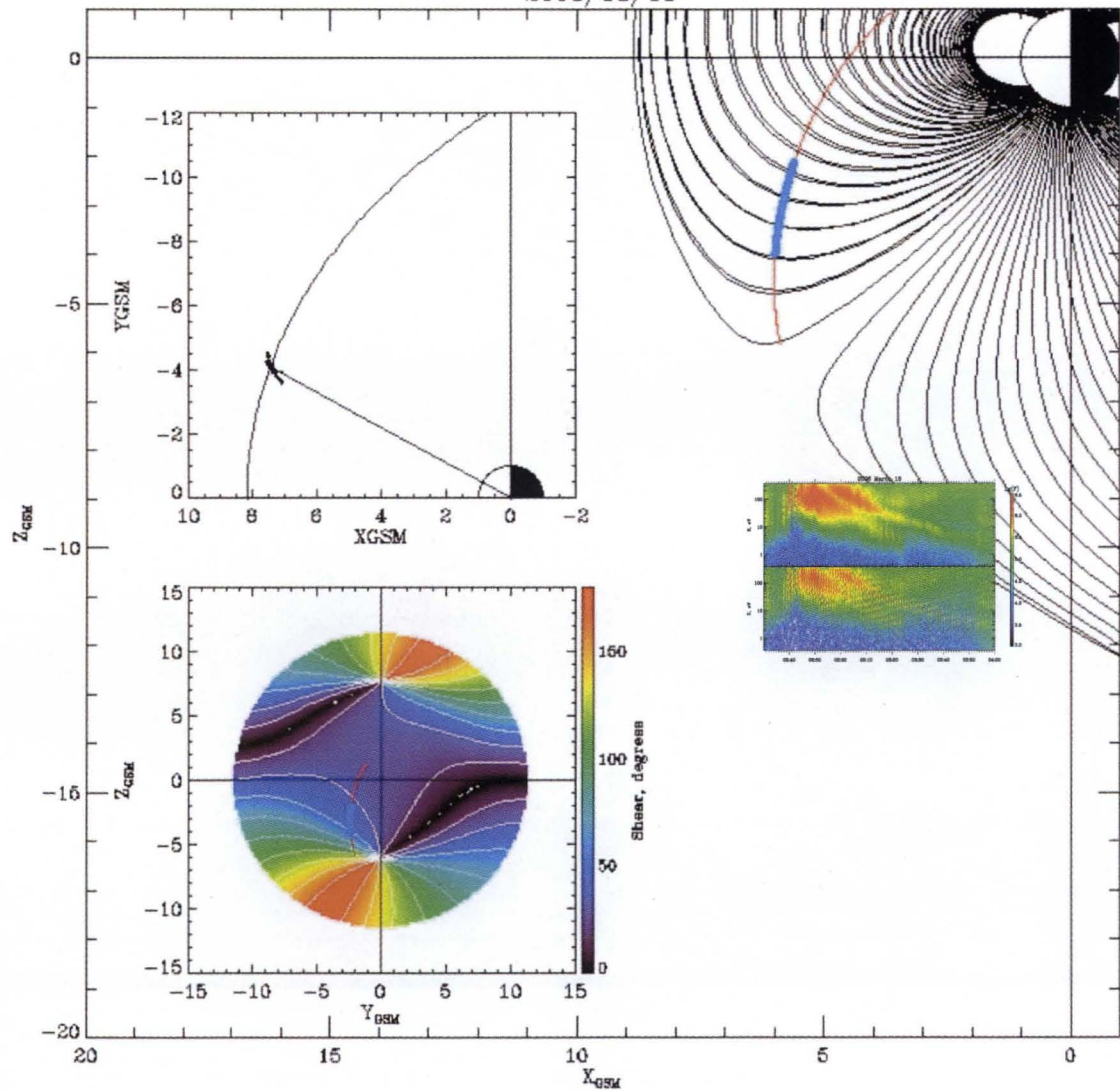



2008 March 18

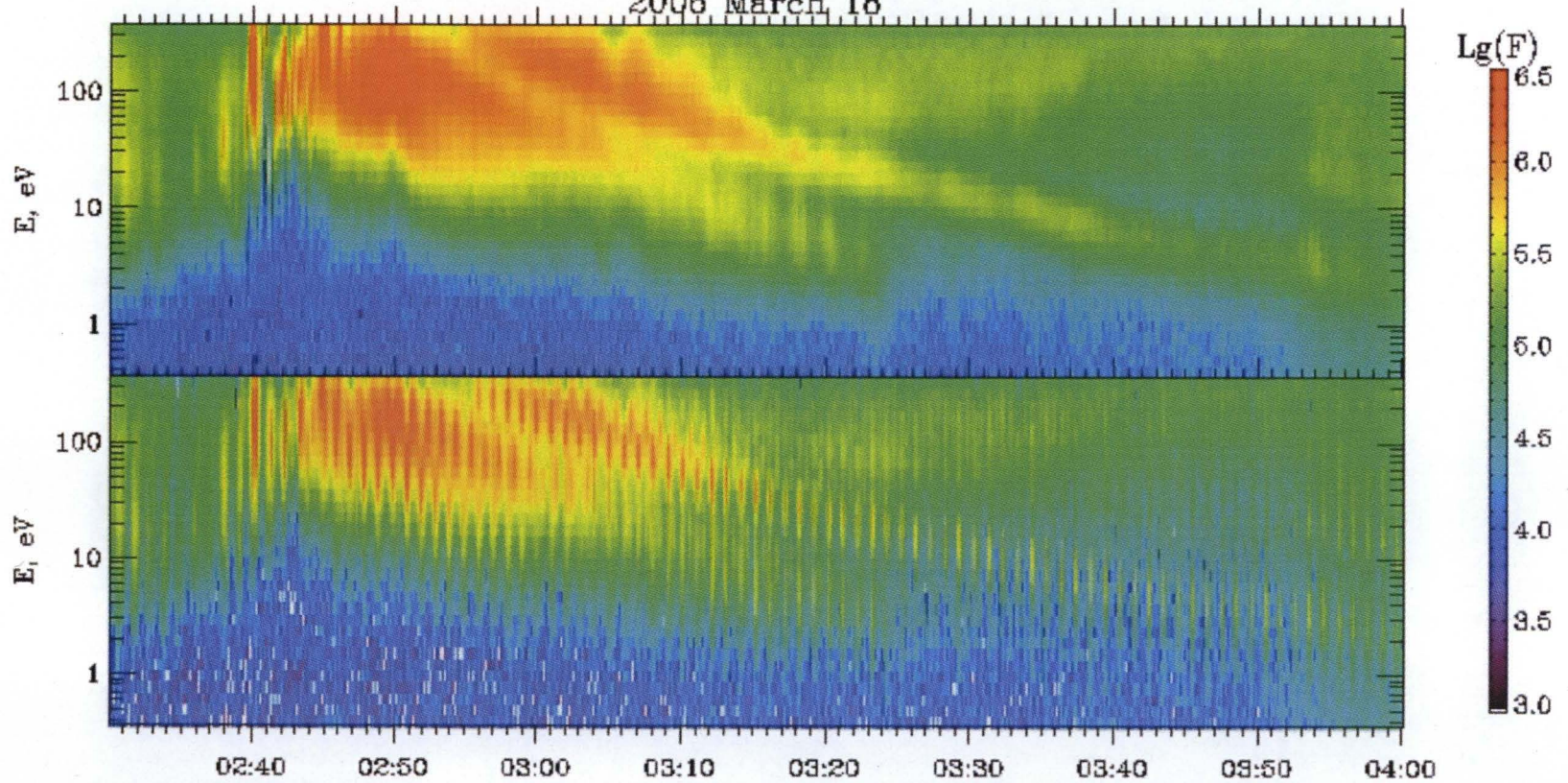

Conditions:

- Polar in the high altitude cusp
- Northward IMF
- Moderately high dynamic pressure

Observations:

- Overlapping magnetosheath injections
- Long-lived spatial/temporal energy dispersions
- Counterstreaming ionospheric populations

Solar wind data taken from GEOTAIL. Geotail was located close to the magnetopause at GSM = [11, -8, -10.], RE. , and therefore the time delay was minimal (less than 1 min.).

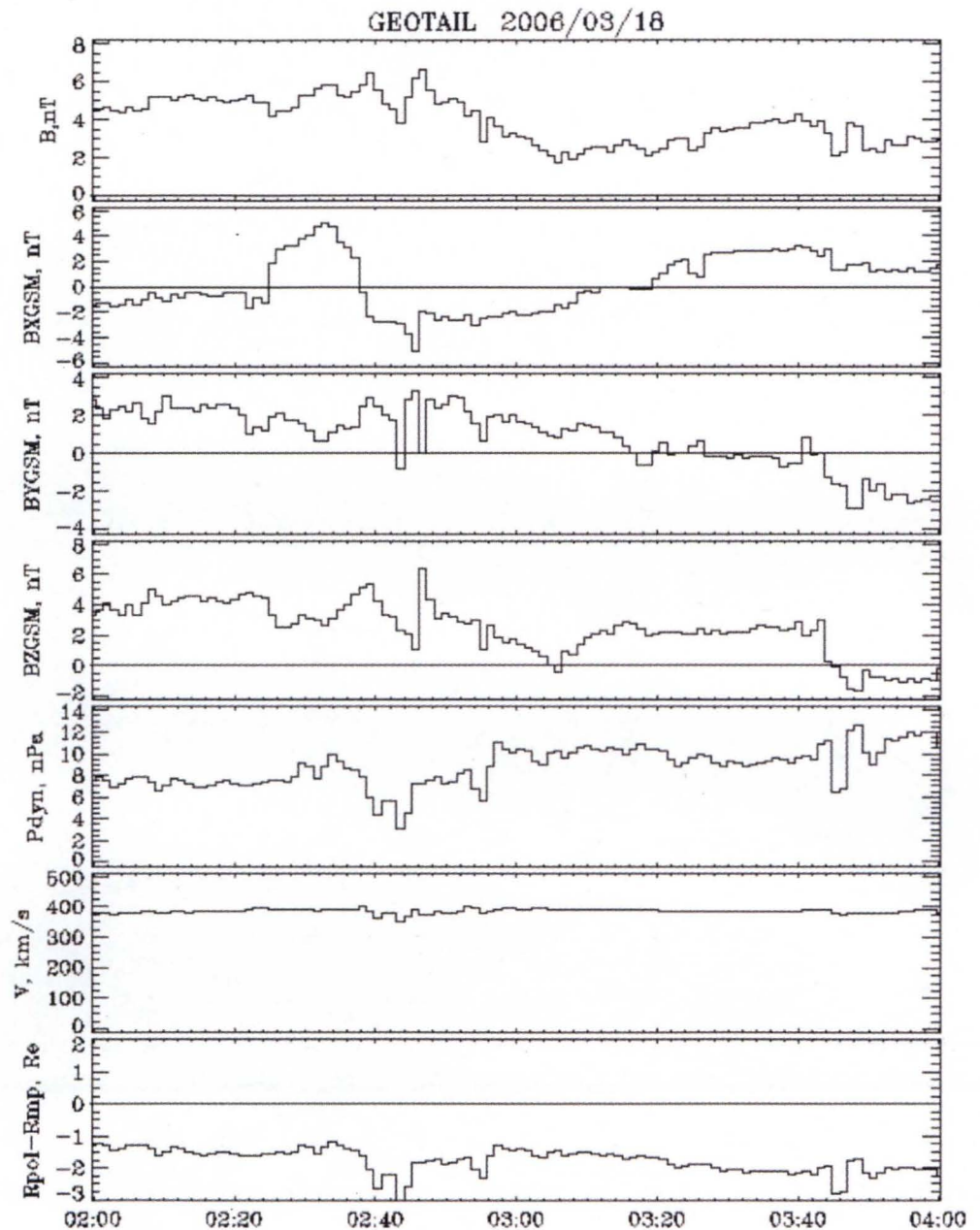



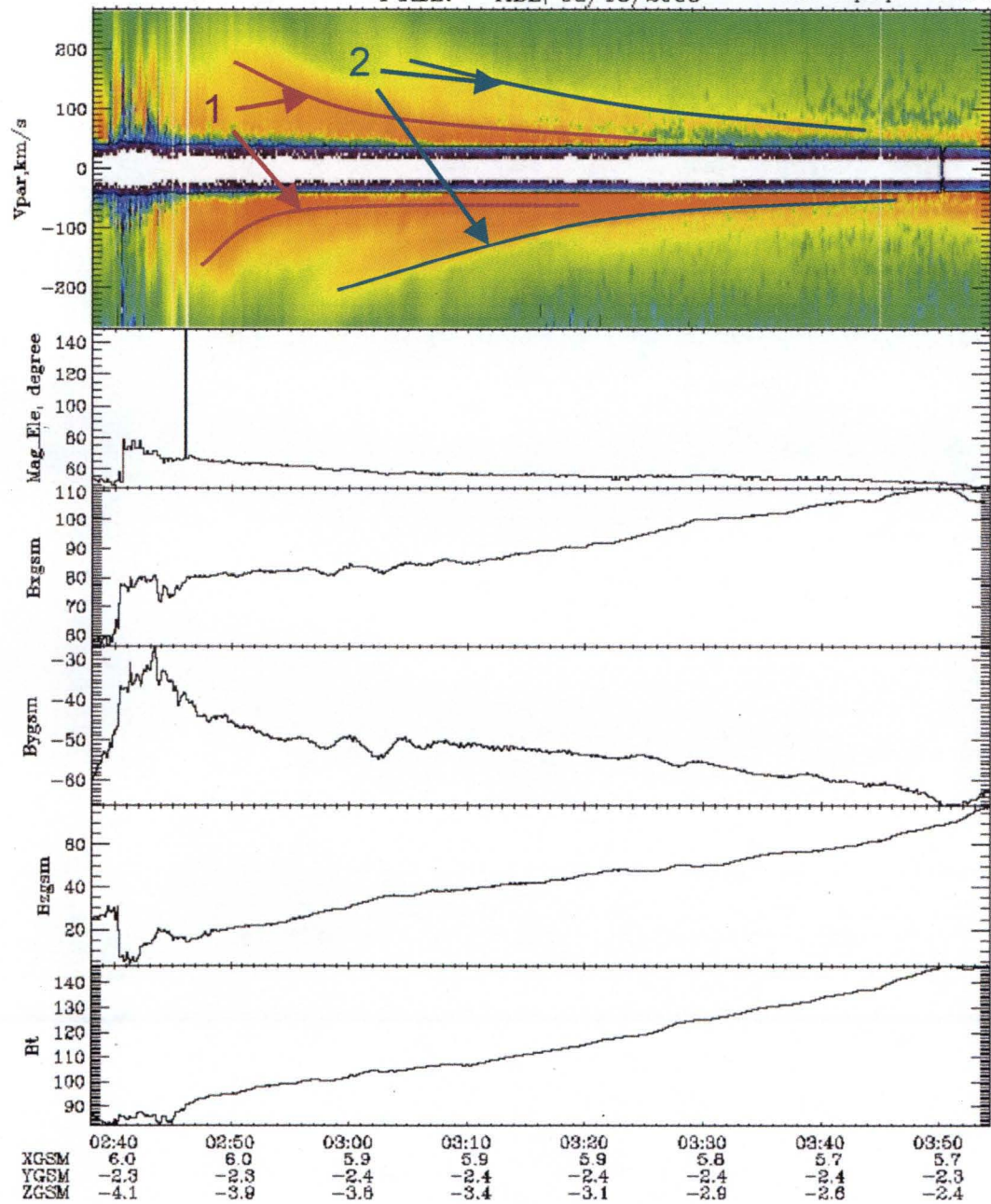



1.  $V = -84.34$ ,  $V_t = 41.0$ ,  $N_d = 57.333$   
2.  $V = 159.30$ ,  $V_t = 55.7$ ,  $N_d = 0.593$

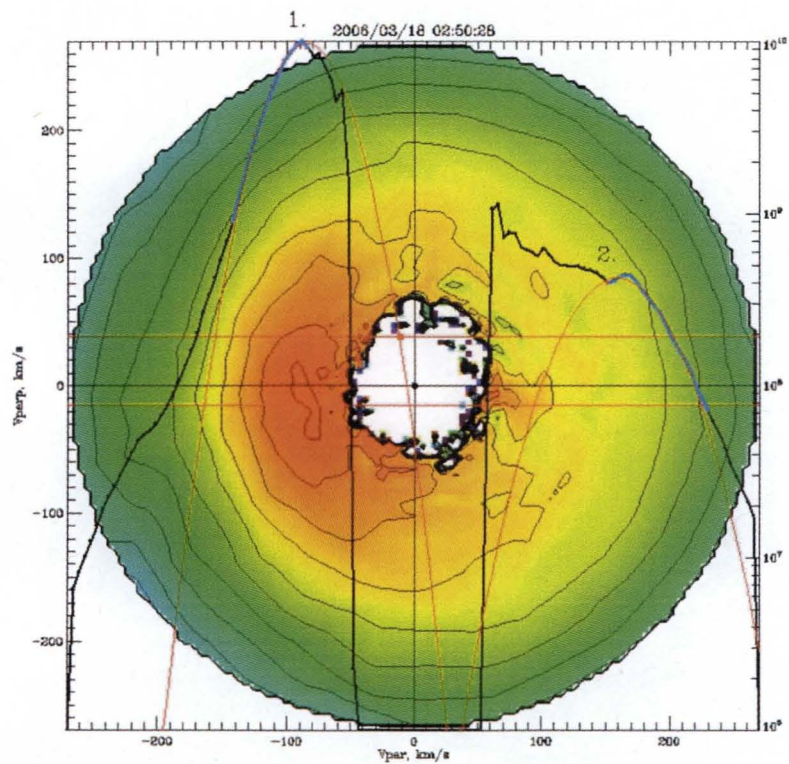

1.  $V = -169.71$ ,  $V_t = 43.9$ ,  $N_d = 5.605$   
2.  $V = -73.52$ ,  $V_t = 36.2$ ,  $N_d = 29.943$   
3.  $V = 94.31$ ,  $V_t = 32.6$ ,  $N_d = 23.534$   
4.  $V = 163.88$ ,  $V_t = 91.3$ ,  $N_d = 2.712$

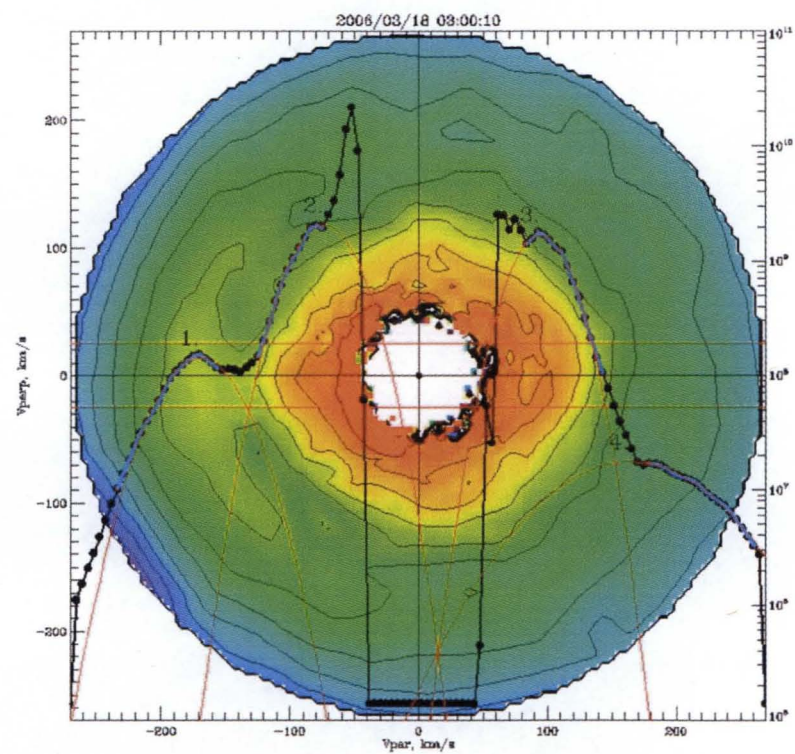

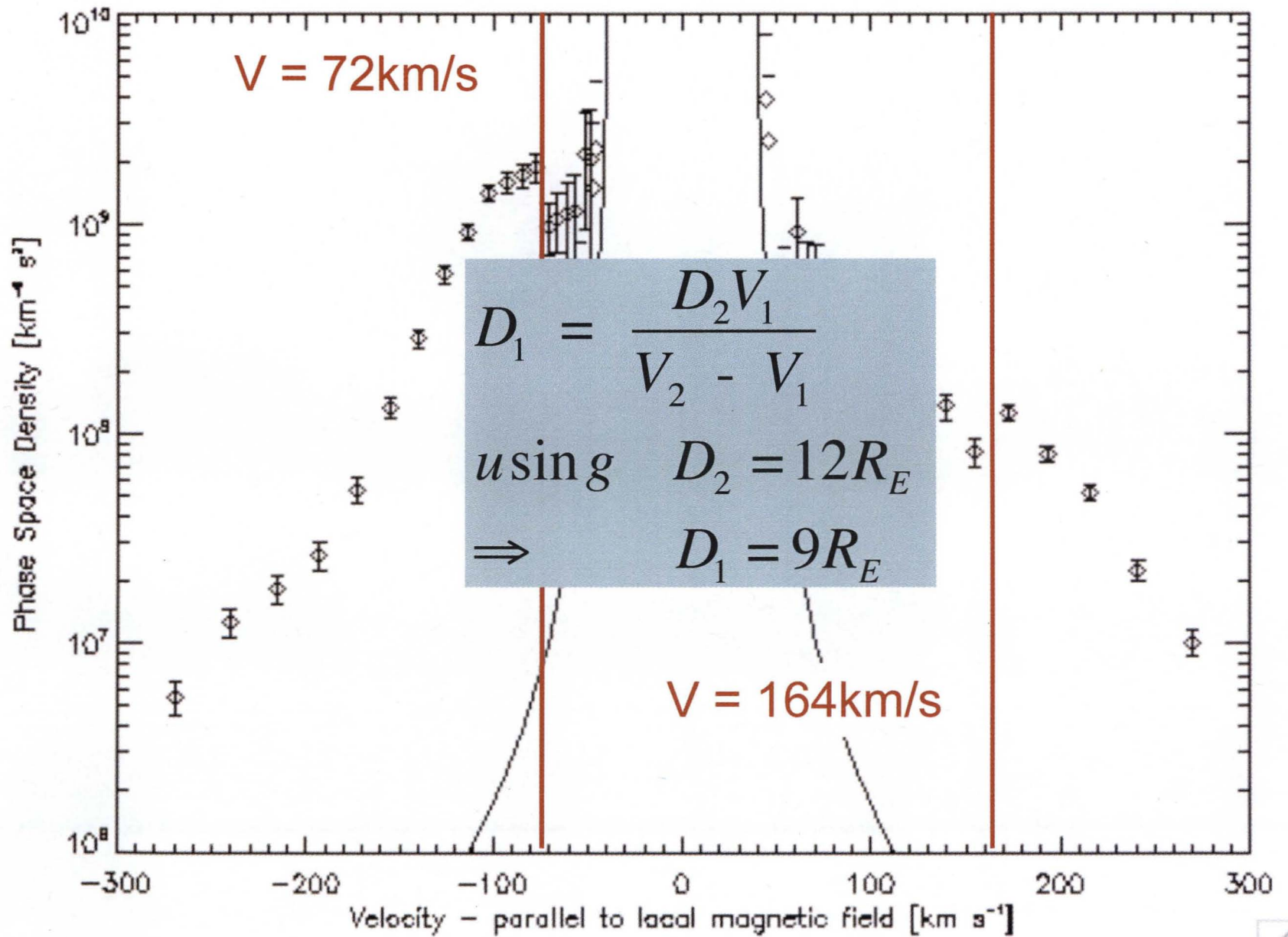

# Distance Estimate from 1<sup>st</sup> Dispersion

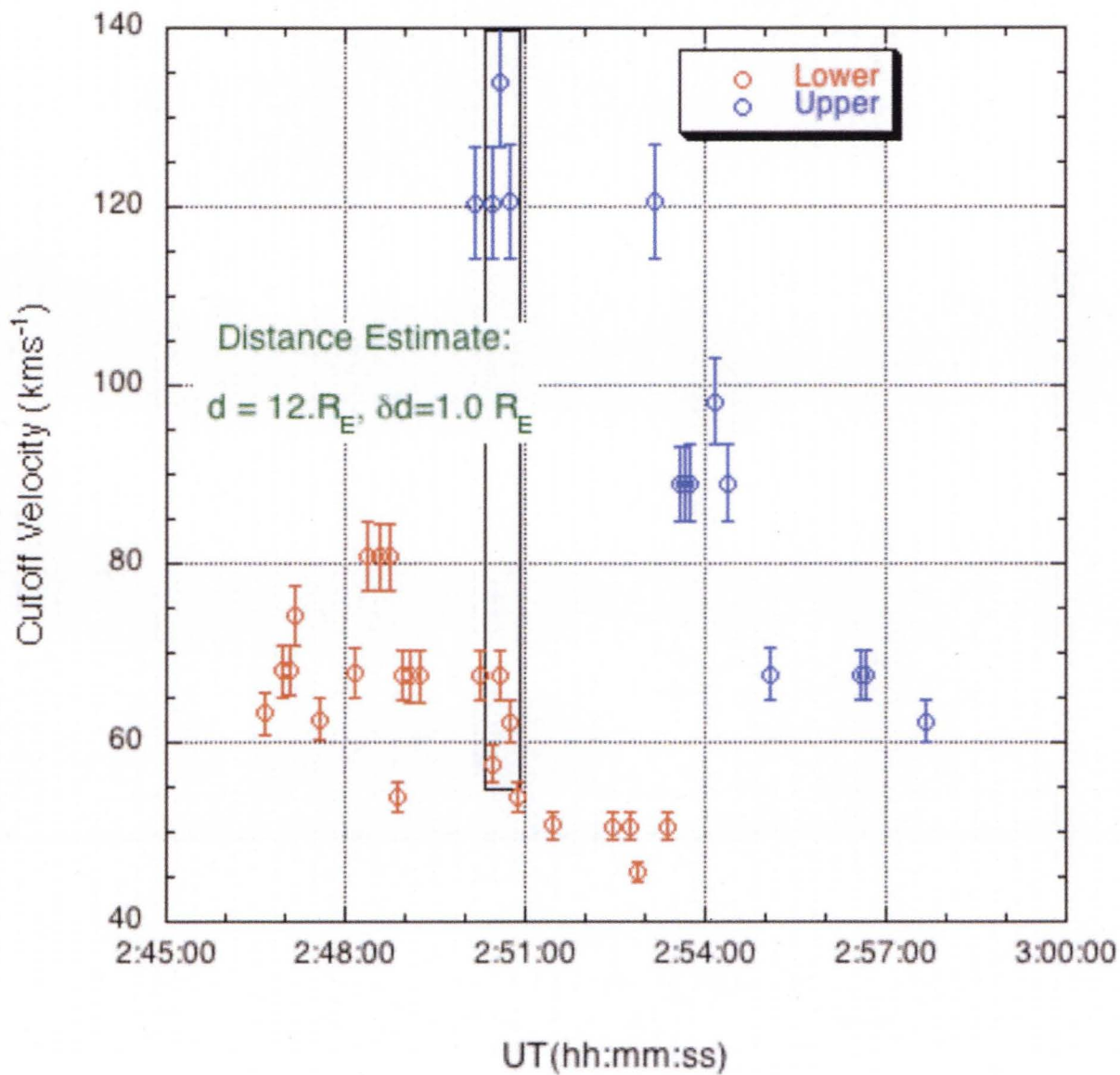



## Dispersion 2

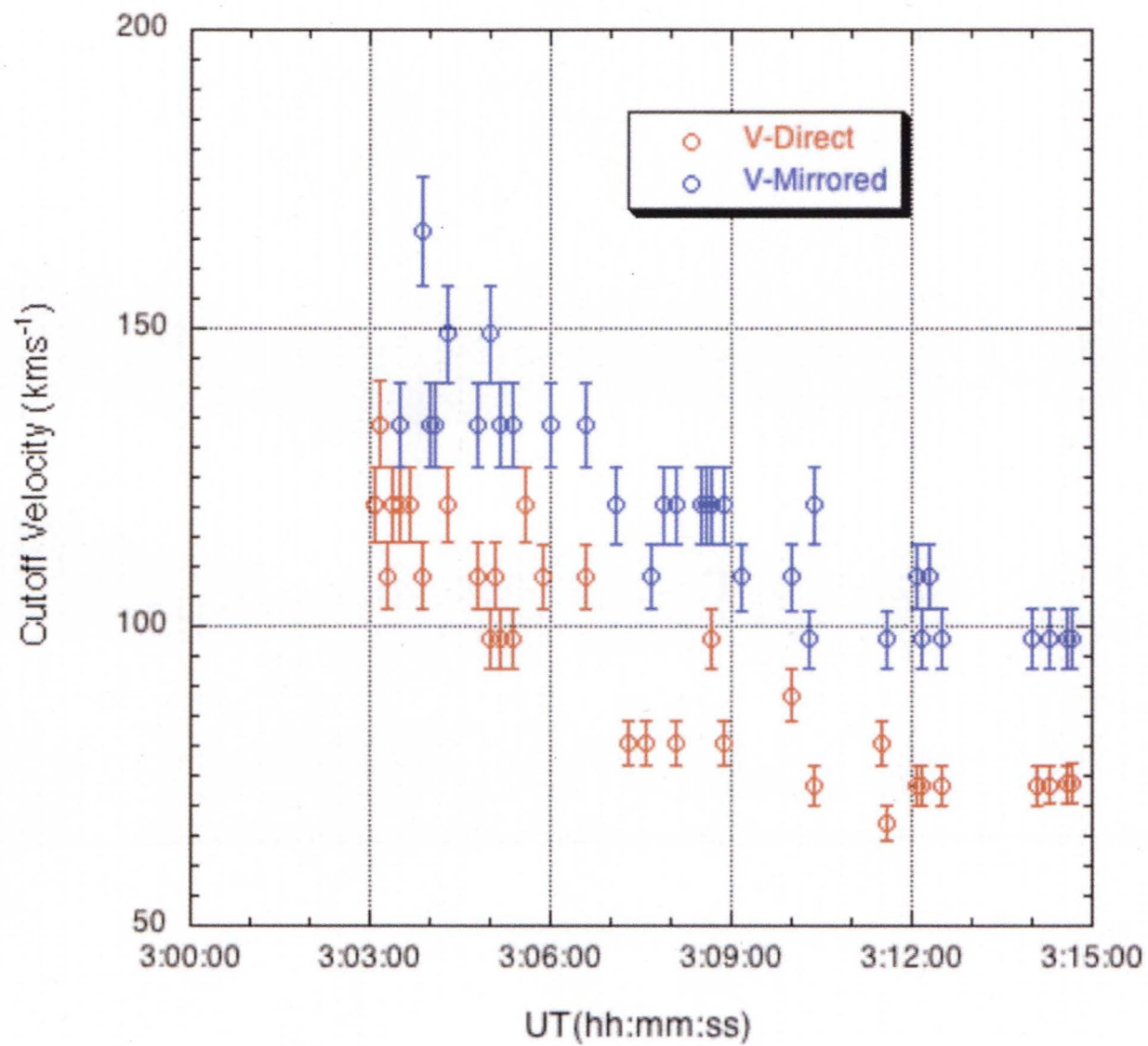

### Distance to Injection Point Dispersion 2

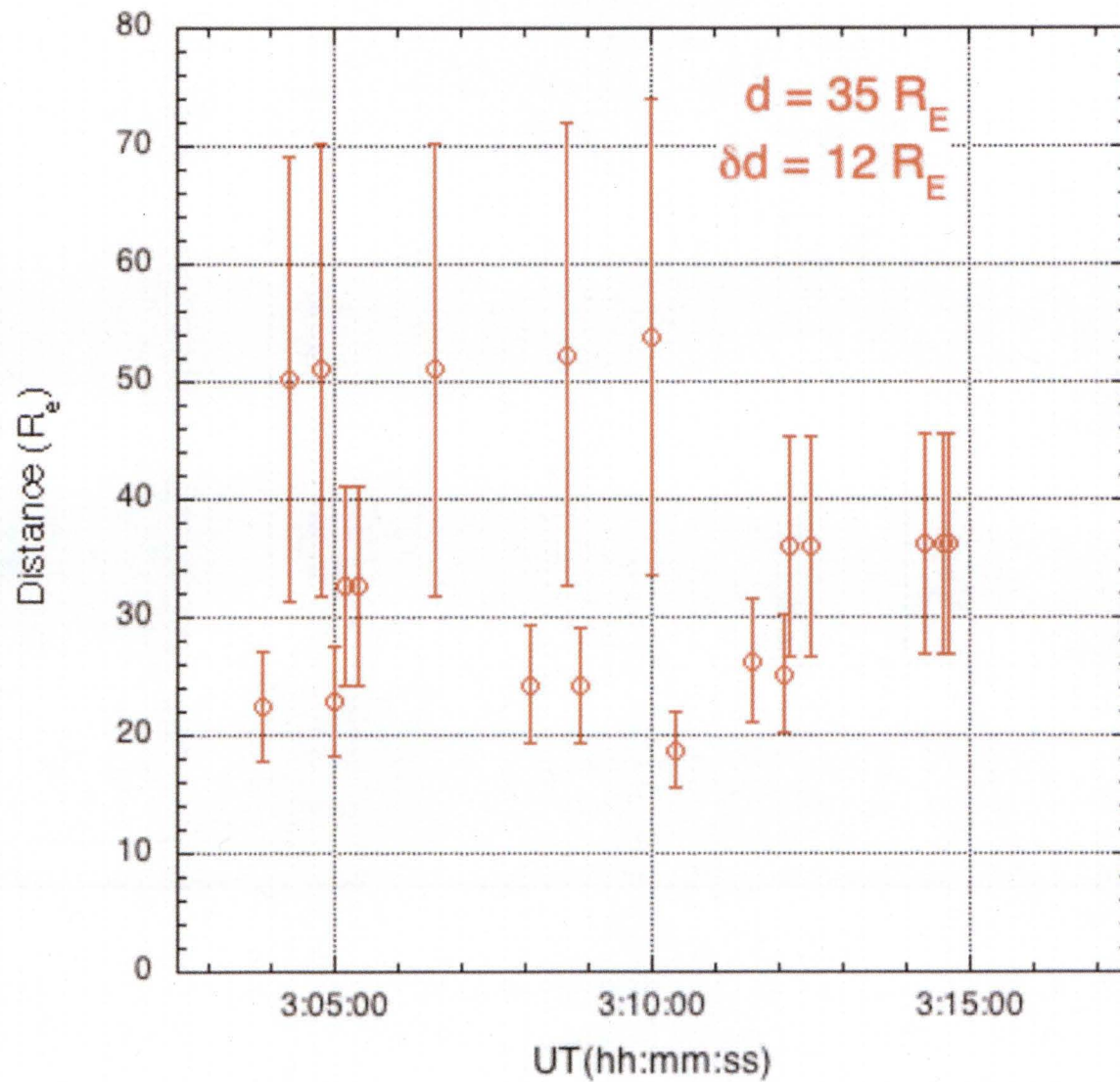

### Dispersion 1 Injection Times

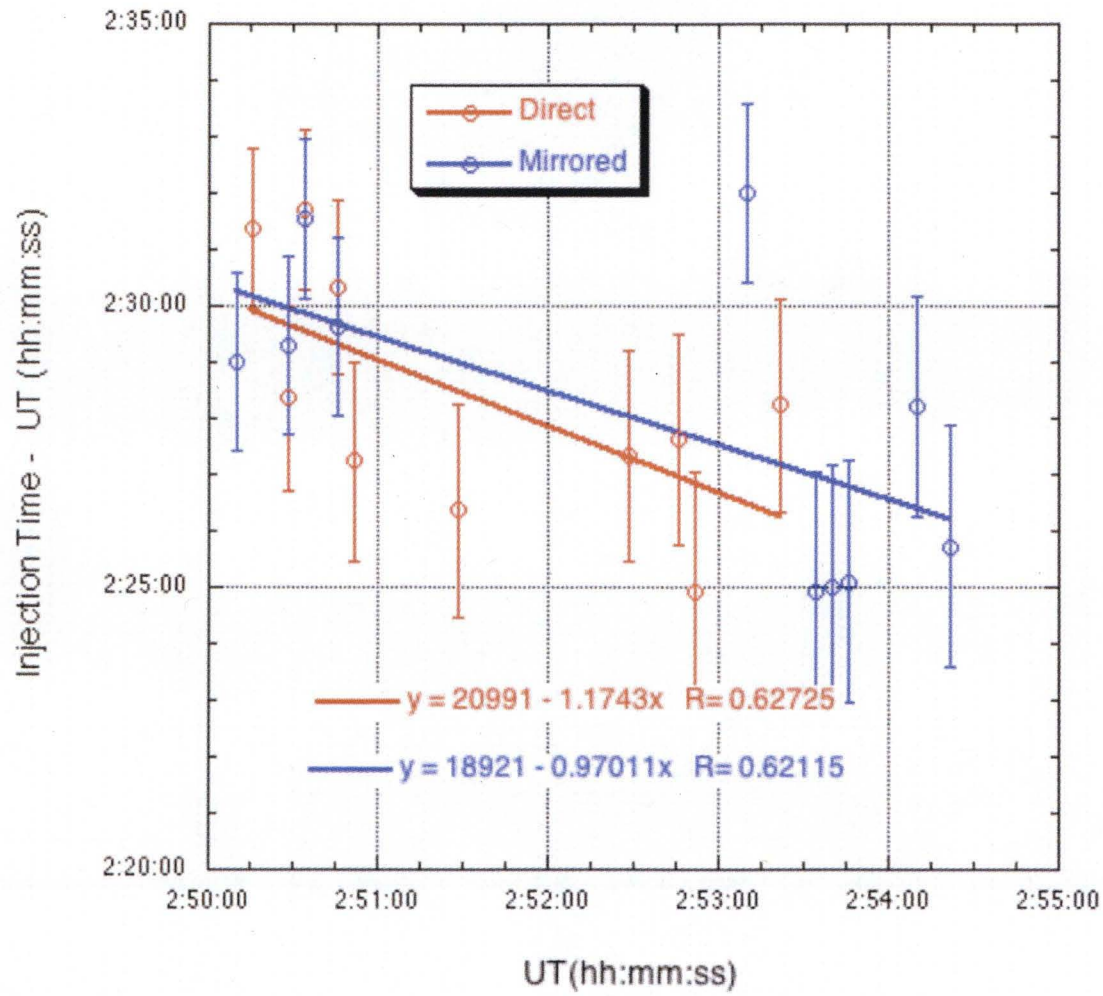



## Dispersion 2 Injection Times

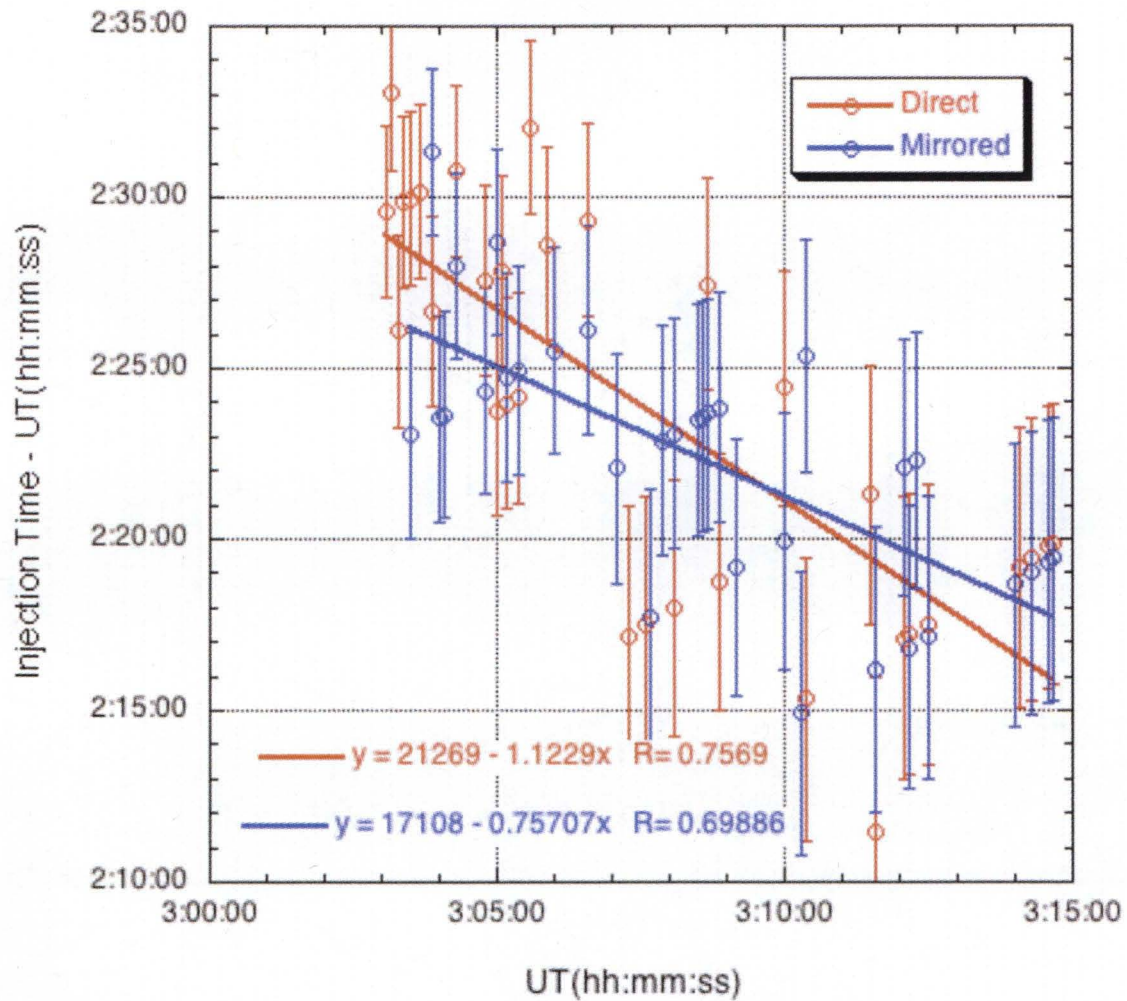

### Comparison of Injections Times

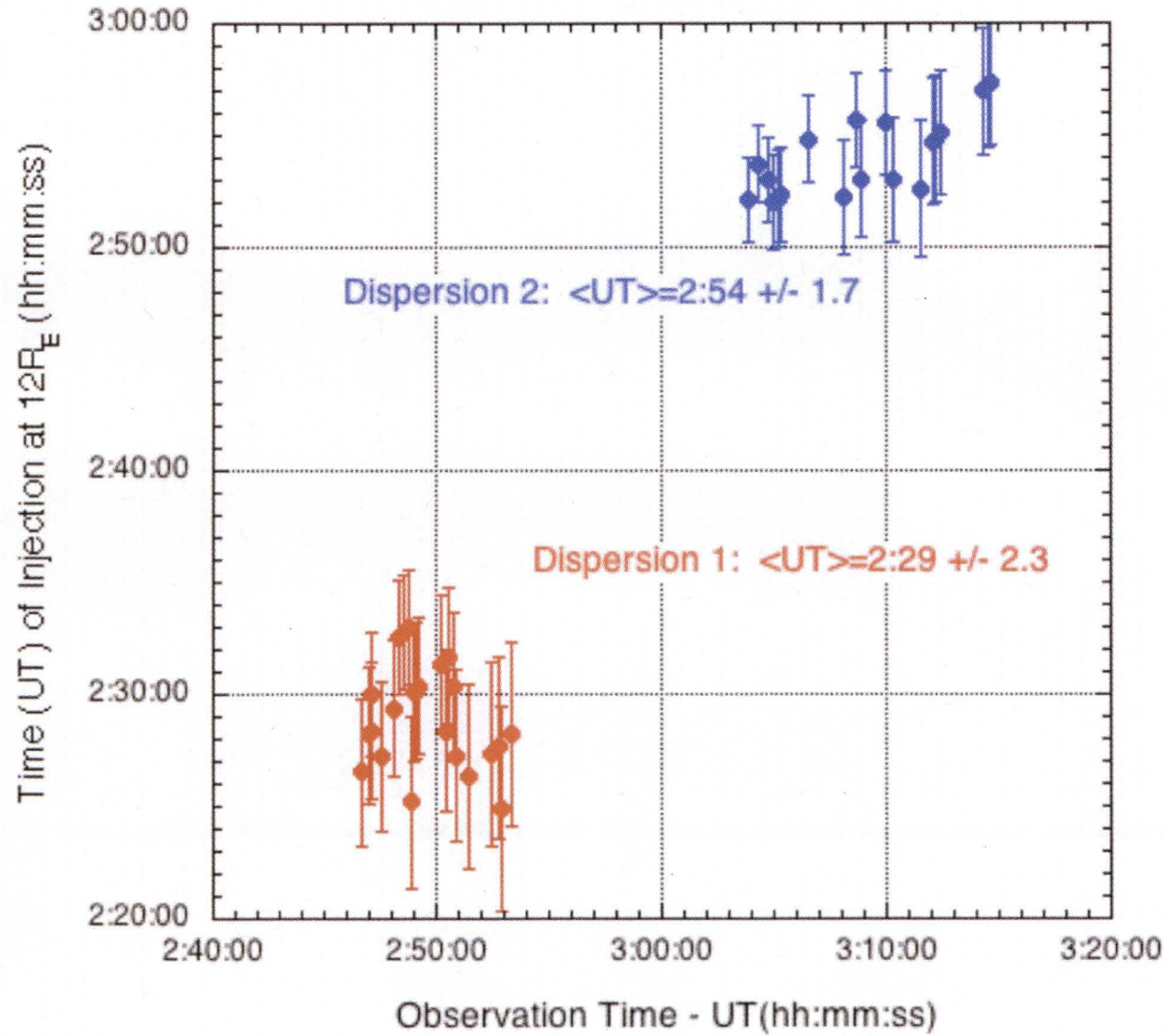

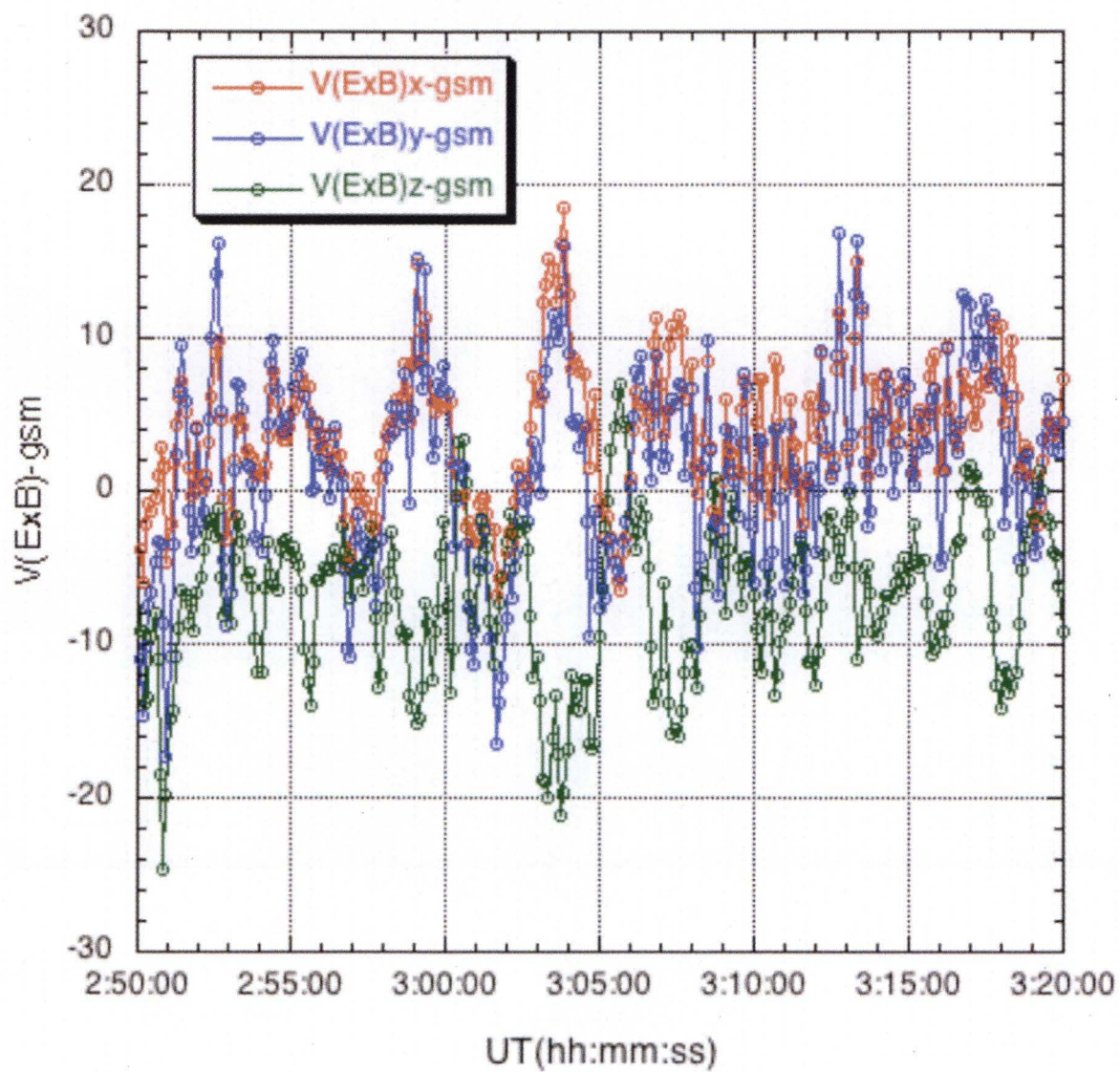

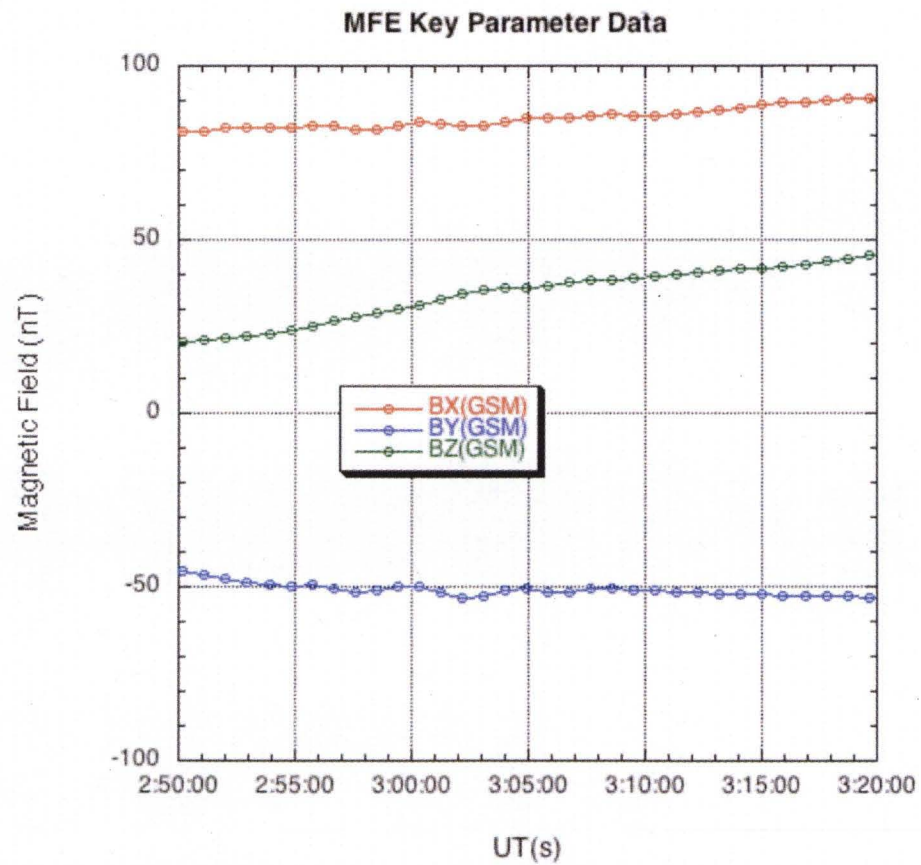
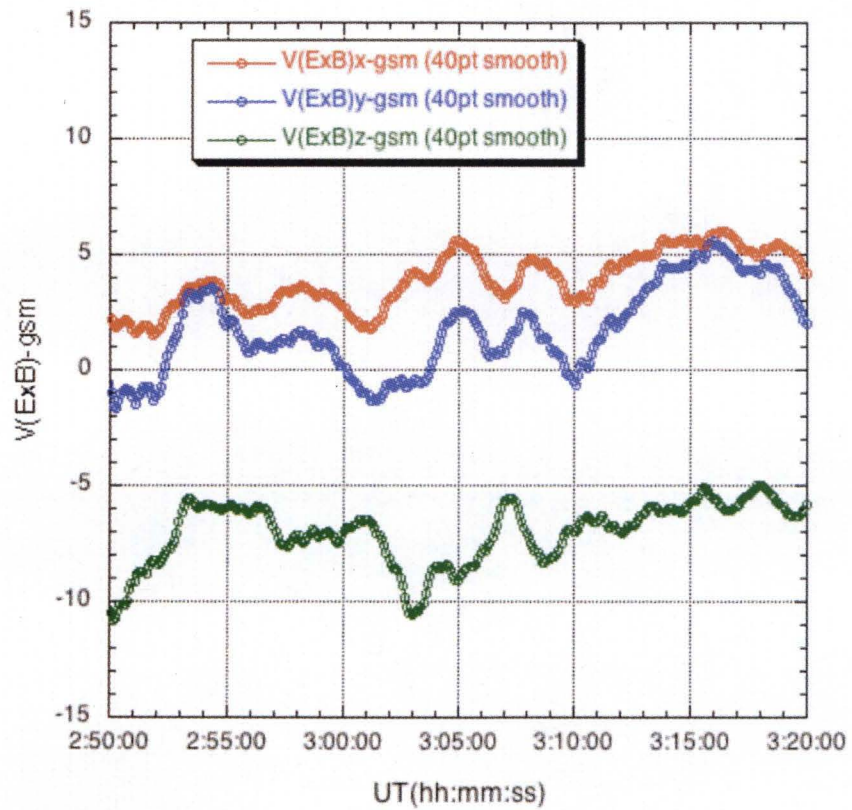



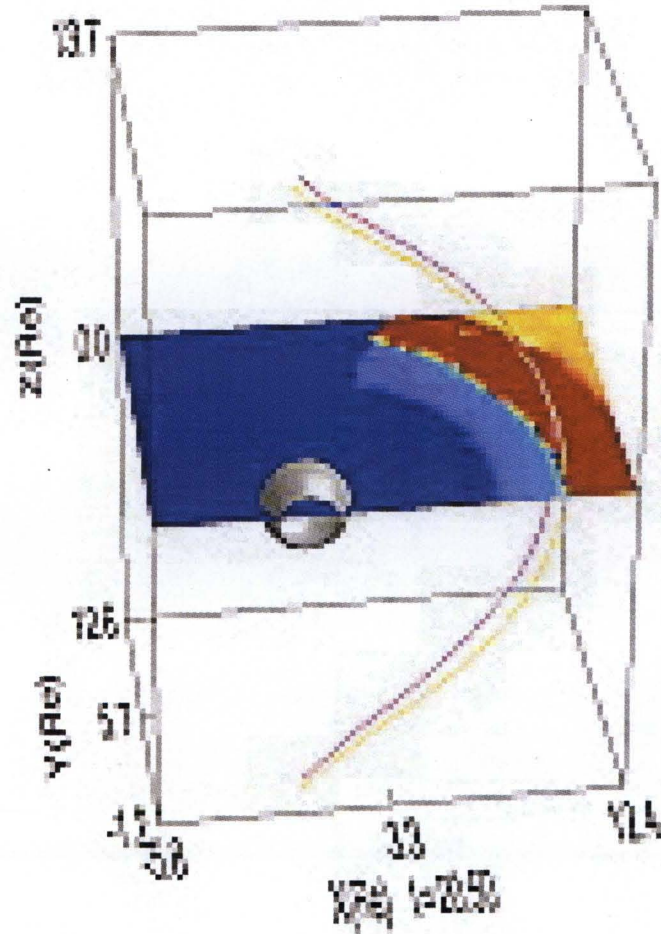

Formation of dayside low-latitude boundary layer under northward IMF,  
 Y. Lin and X.Y. Wang Geophys. Res. Lett., 33, L21104, doi: 10.1029/2006gl027736

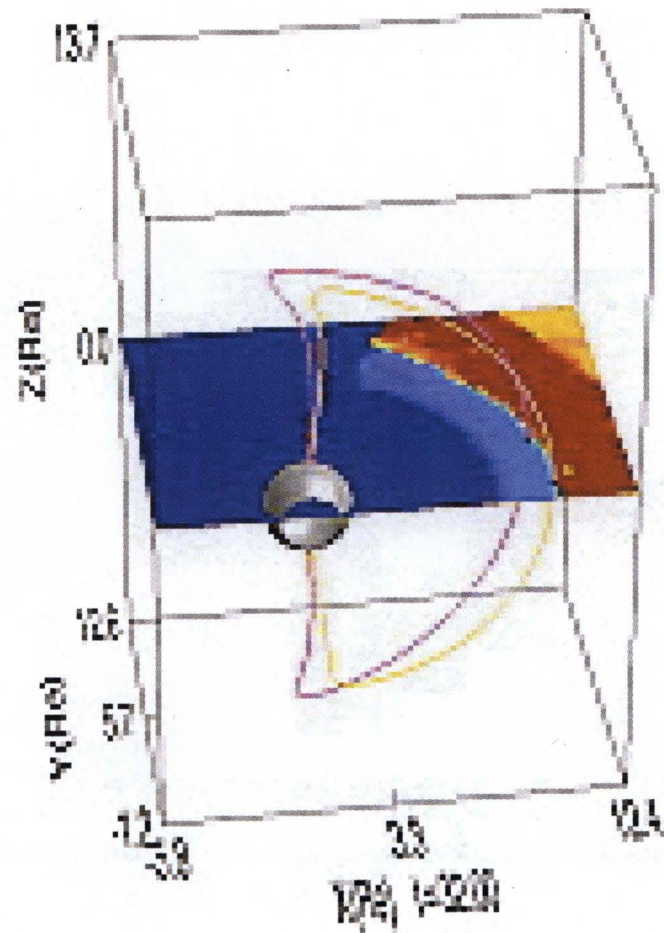

Formation of dayside low-latitude boundary layer under northward IMF,  
 Y. Lin and X.Y. Wang Geophys. Res. Lett, 33, L21104, doi: 10.1029/2006gl027736

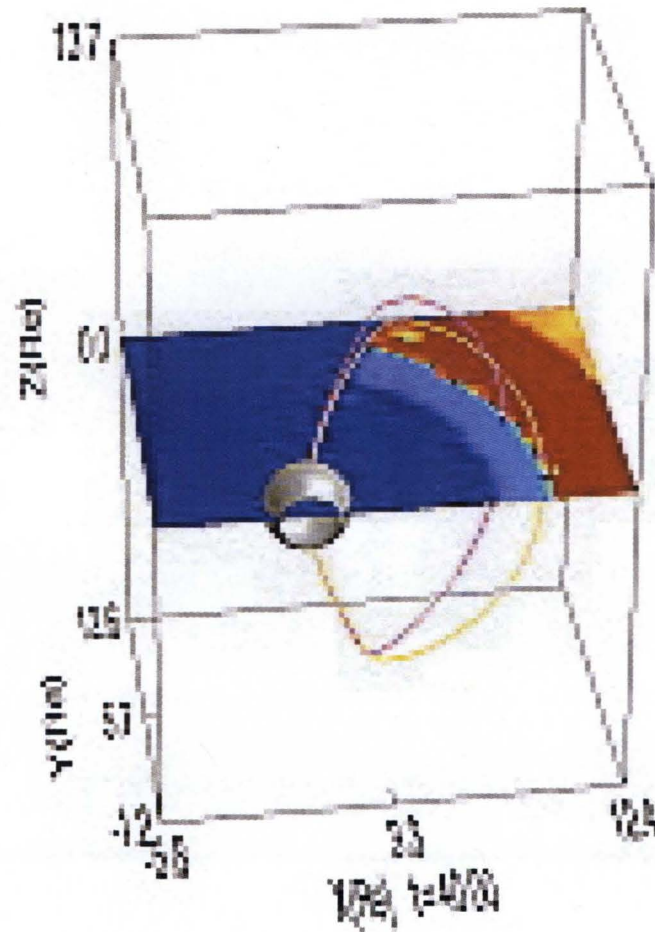

Formation of dayside low-latitude boundary layer under northward IMF,  
 Y. Lin and X.Y. Wang Geophys. Res. Lett, 33, L21104, doi: 10.1029/2006gl027736



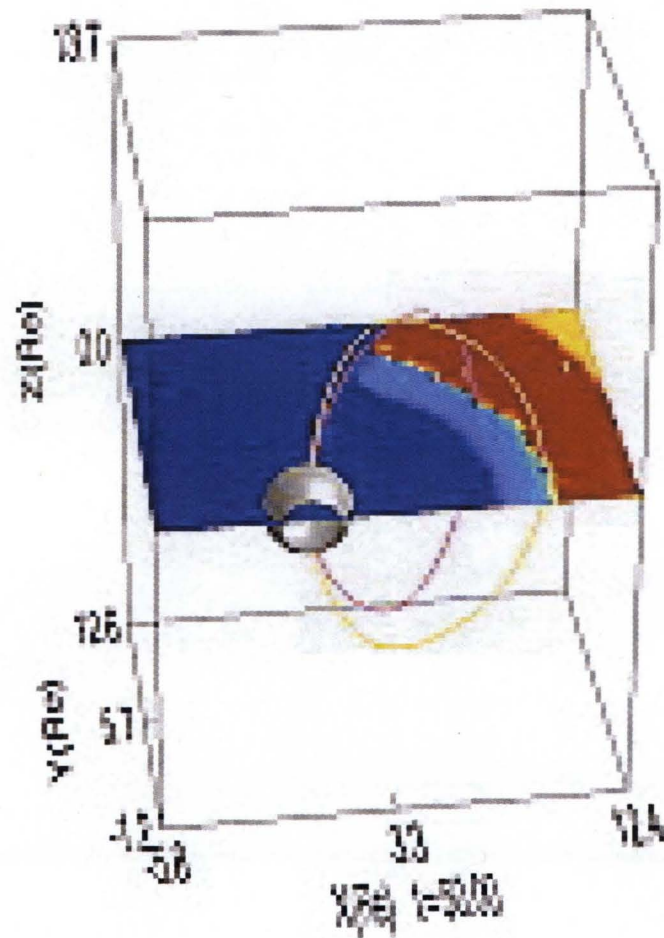

Formation of dayside low-latitude boundary layer under northward IMF,  
 Y. Lin and X.Y. Wang Geophys. Res. Lett., 33, L21104, doi: 10.1029/2006gl027736

2006/03/18 02:50:00-03:40:00 UT

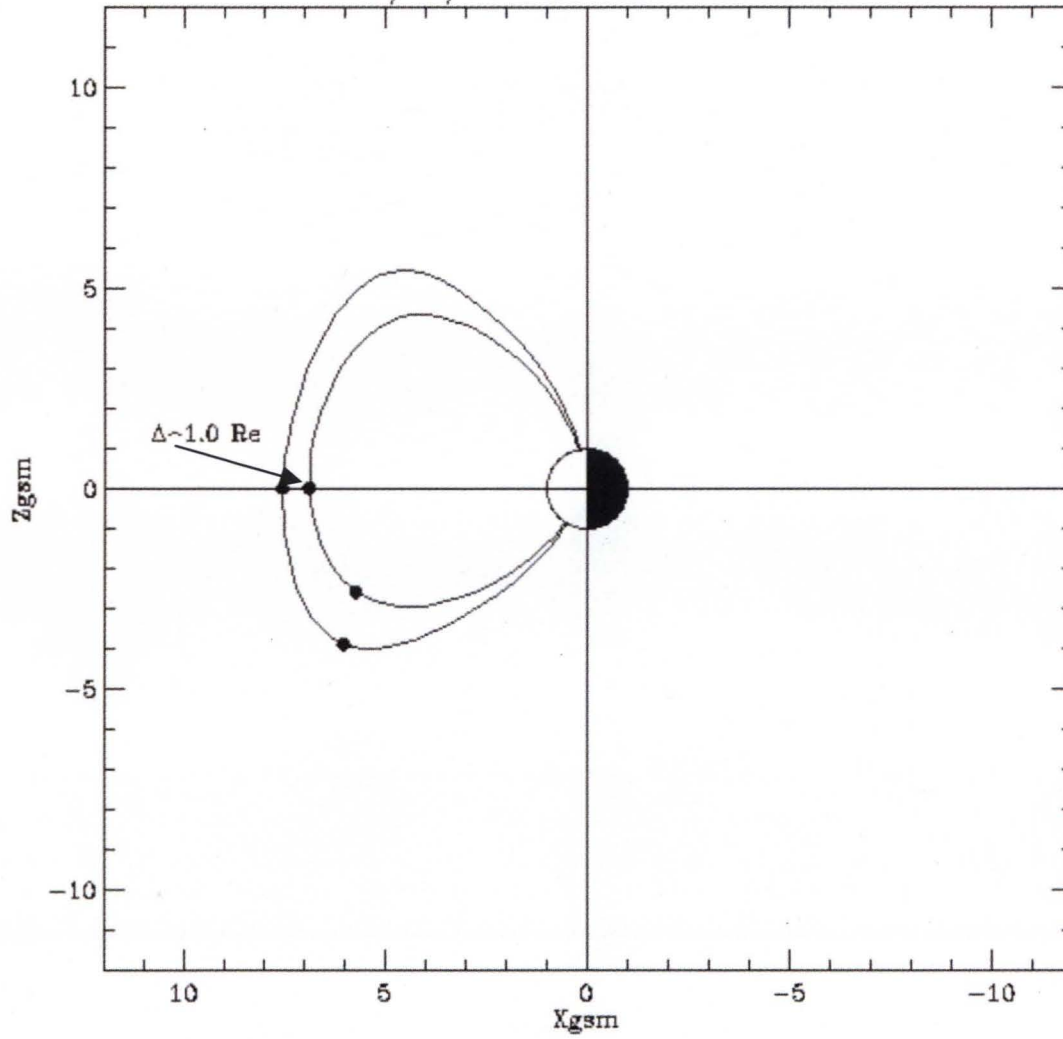

2006/03/18

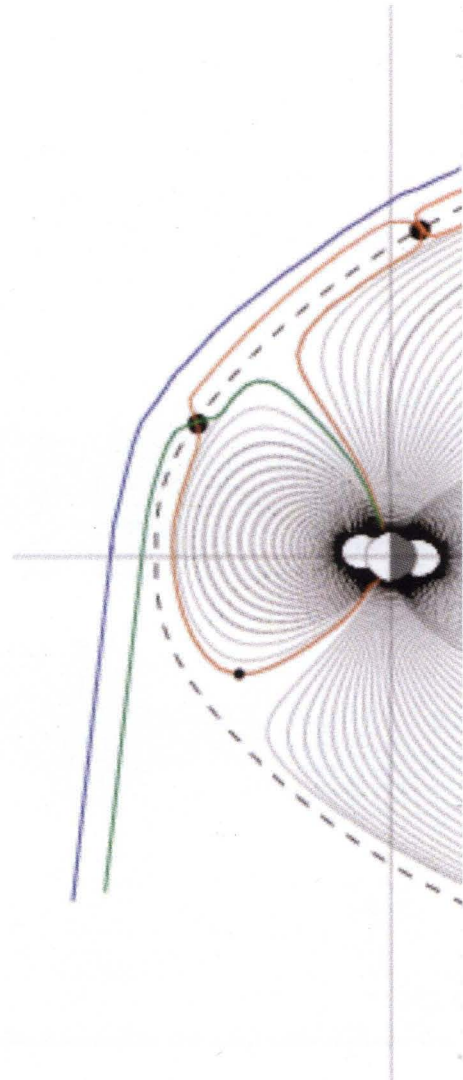
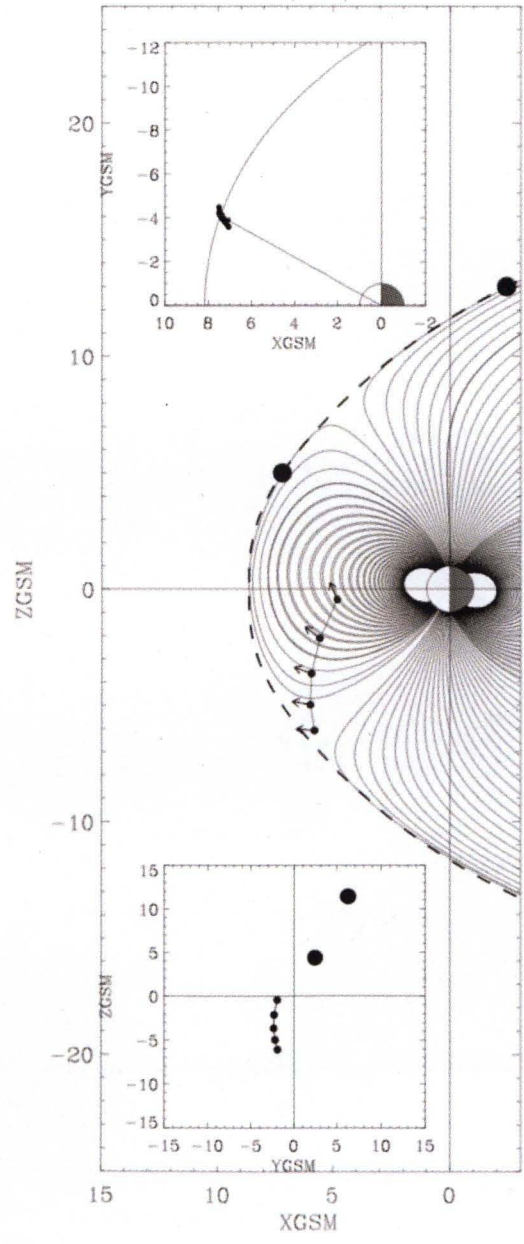



2008/03/18

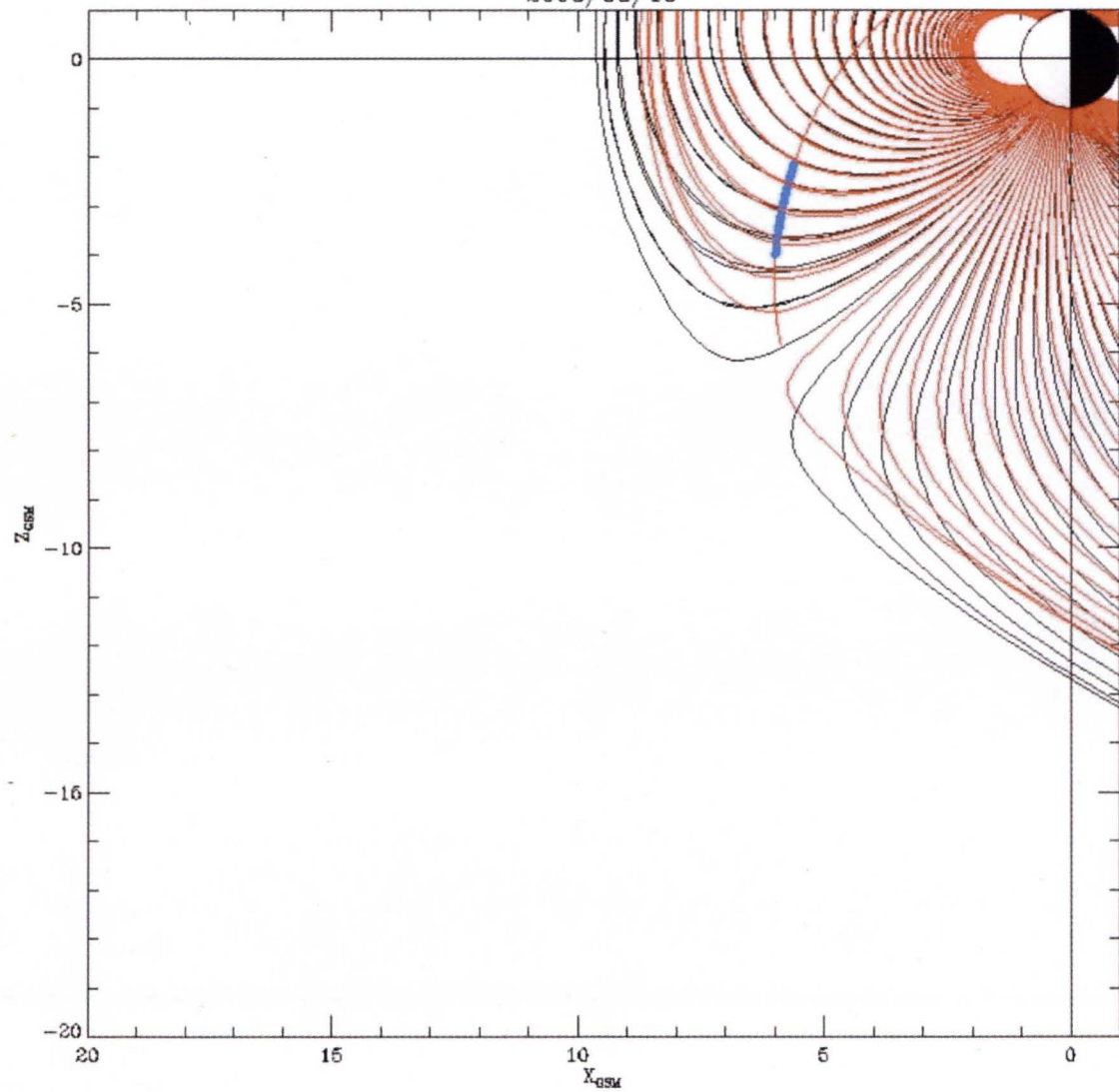

## Summary/Conclusions

- Apparent double injection on same field lines
- Counterstreaming ionospheric ions implies closed field lines
- Preliminary analysis suggests “double reconnection” in opposite Hemispheres
- Reanalysis confirms distances to the two reconnections sites
- Electric field results show a predominantly southward motion of the field lines - not consistent with expected field line motion following post-cusp reconnection
- It could be consistent with doubly reconnected field lines with reconnections sites in the northern post-cusp region and at low-latitudes
- This is not consistent with the “age” of the plasma on these field lines
- Possible that convective motion results from compression of the field by increasing solar wind pressure.