

United States Patent [19][11] **4,084,090****Boettger et al.**[45] **Apr. 11, 1978****[54] AUTOMATED MASS SPECTROMETER ANALYSIS SYSTEM**

[75] Inventors: Heinz G. Boettger, La Canada; Charles E. Giffin, Pasadena; William J. Dreyer; Aron Kuppermann, both of Altadena, all of Calif.

[73] Assignee: California Institute of Technology, Pasadena, Calif.

[21] Appl. No.: 587,097

[22] Filed: Jun. 16, 1975

[51] Int. Cl.² B01D 59/44; H01J 39/34; H01J 39/48

[52] U.S. Cl. 250/286; 250/300

[58] Field of Search 250/281, 286, 300

[56]

References Cited**U.S. PATENT DOCUMENTS**

3,510,647 5/1970 Wood 250/281
3,602,709 8/1971 Hull 250/286

Primary Examiner—Alfred E. Smith

Assistant Examiner—T. N. Grigsby

Attorney, Agent, or Firm—Lindenbergh, Freilich, Hornbaker, Wasserman, Rosen & Fernandez

[57]

ABSTRACT

An automated mass spectrometer analysis system is

disclosed, in which samples are automatically processed in a sample processor and converted into volatilizable samples, or their characteristic volatilizable derivatives. Each volatilizable sample is sequentially volatilized and analyzed in a double focusing mass spectrometer, whose output is in the form of separate ion beams all of which are simultaneously focused in a focal plane. Each ion beam is indicative of a different sample component or different fragments of one or more sample components and the beam intensity is related to the relative abundance of the sample component. The system includes an electro-optical ion detector which automatically and simultaneously converts the ion beams, first into electron beams which in turn produce a related image which is transferred to the target of a vidicon unit. The latter converts the images into electrical signals which are supplied to a data processor, whose output is a list of the components of the analyzed sample and their abundances. The system is under the control of a master control unit, which in addition to monitoring and controlling various power sources, controls the automatic operation of the system under expected and some unexpected conditions and further protects various critical parts of the system from damage due to particularly abnormal conditions.

37 Claims, 6 Drawing Figures

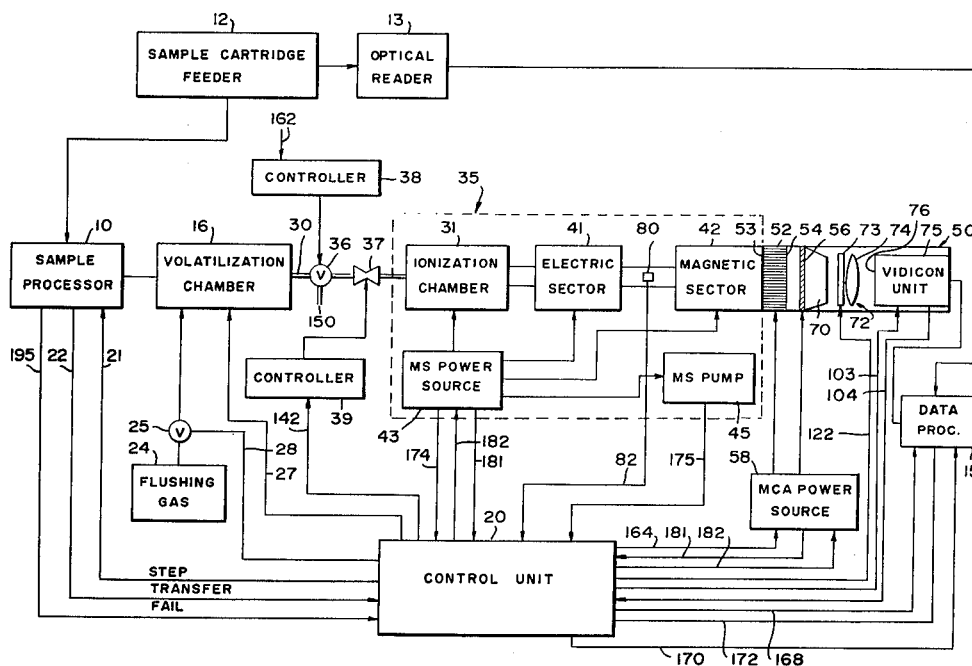
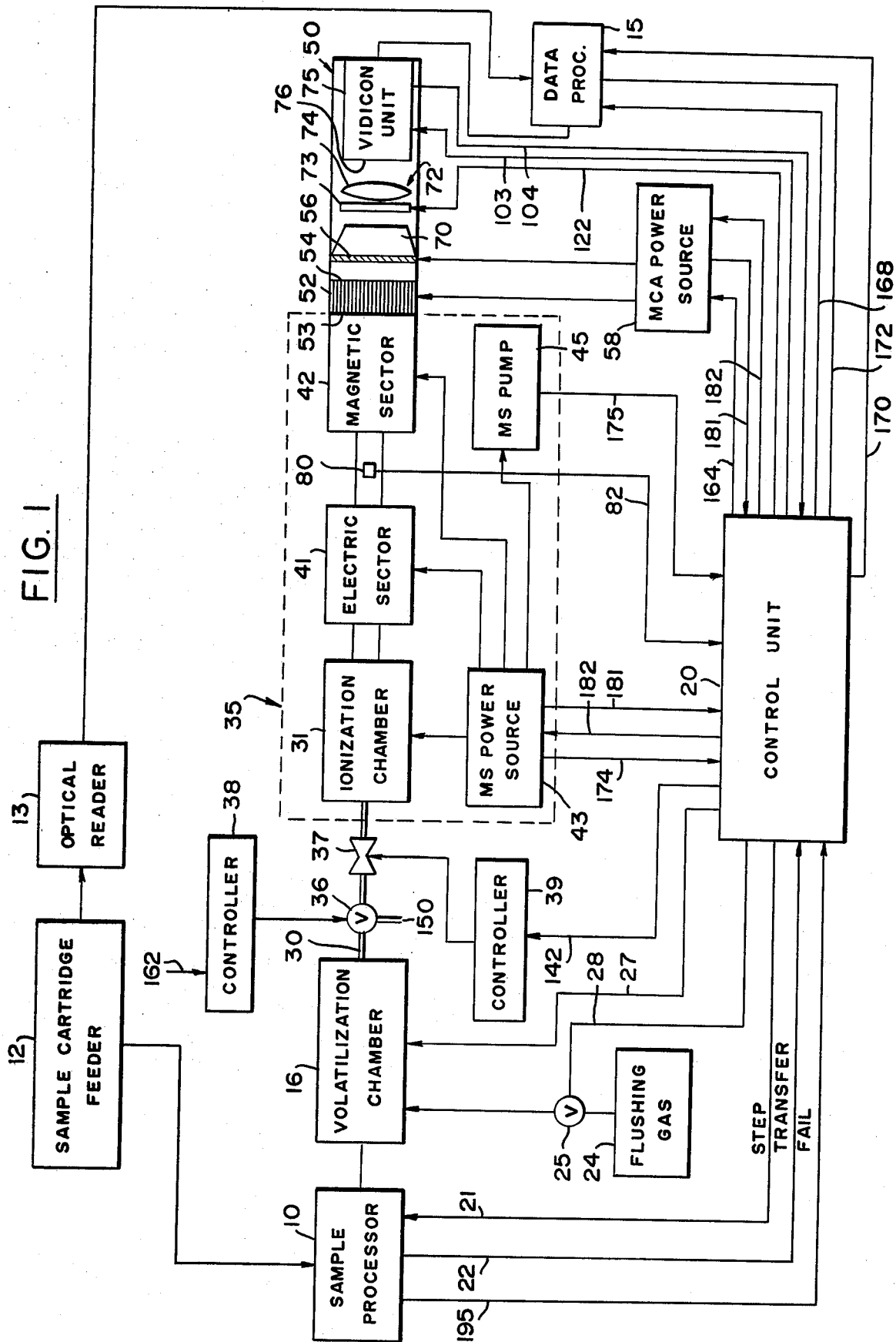

FIG. 1



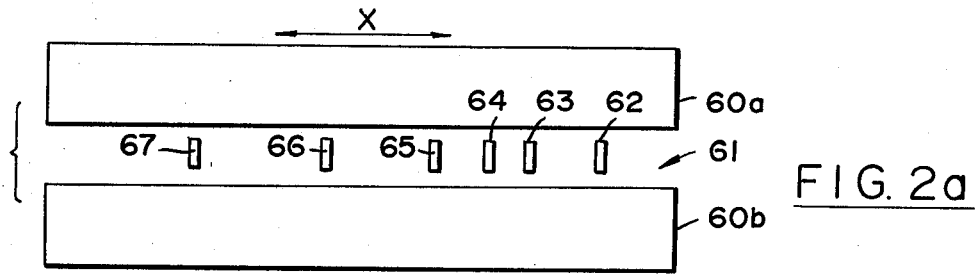

FIG. 2a

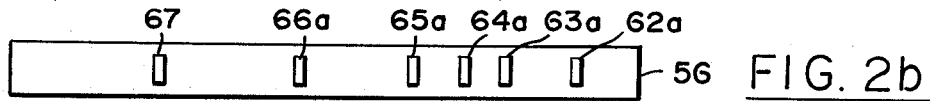

FIG. 2b

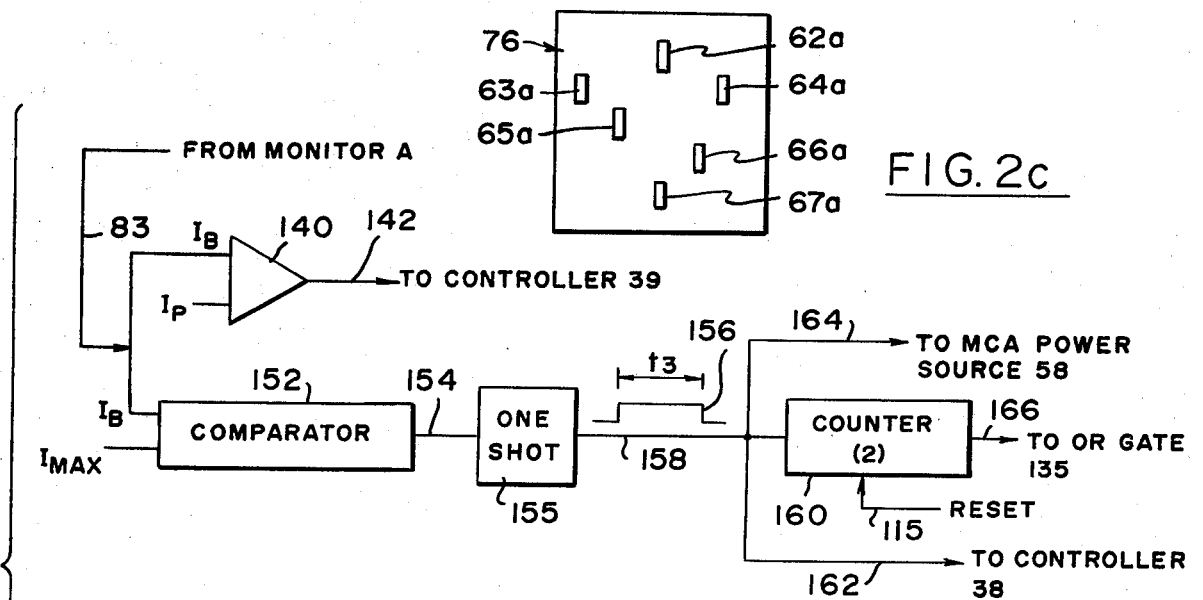

FIG. 2c

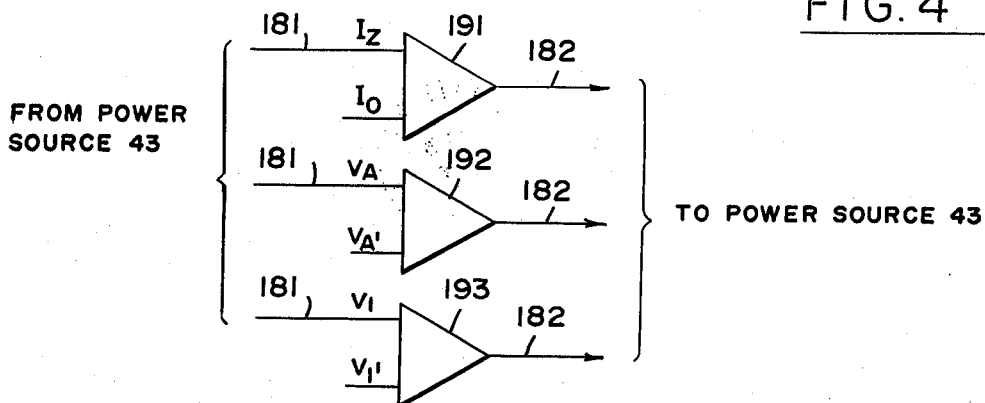
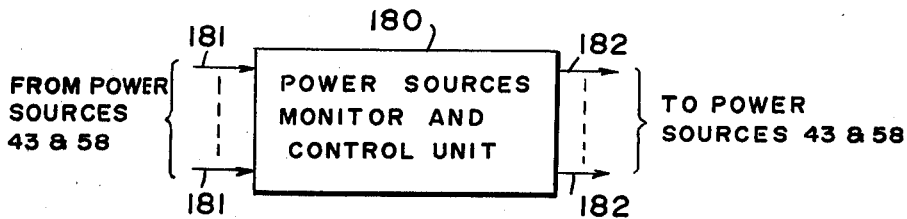
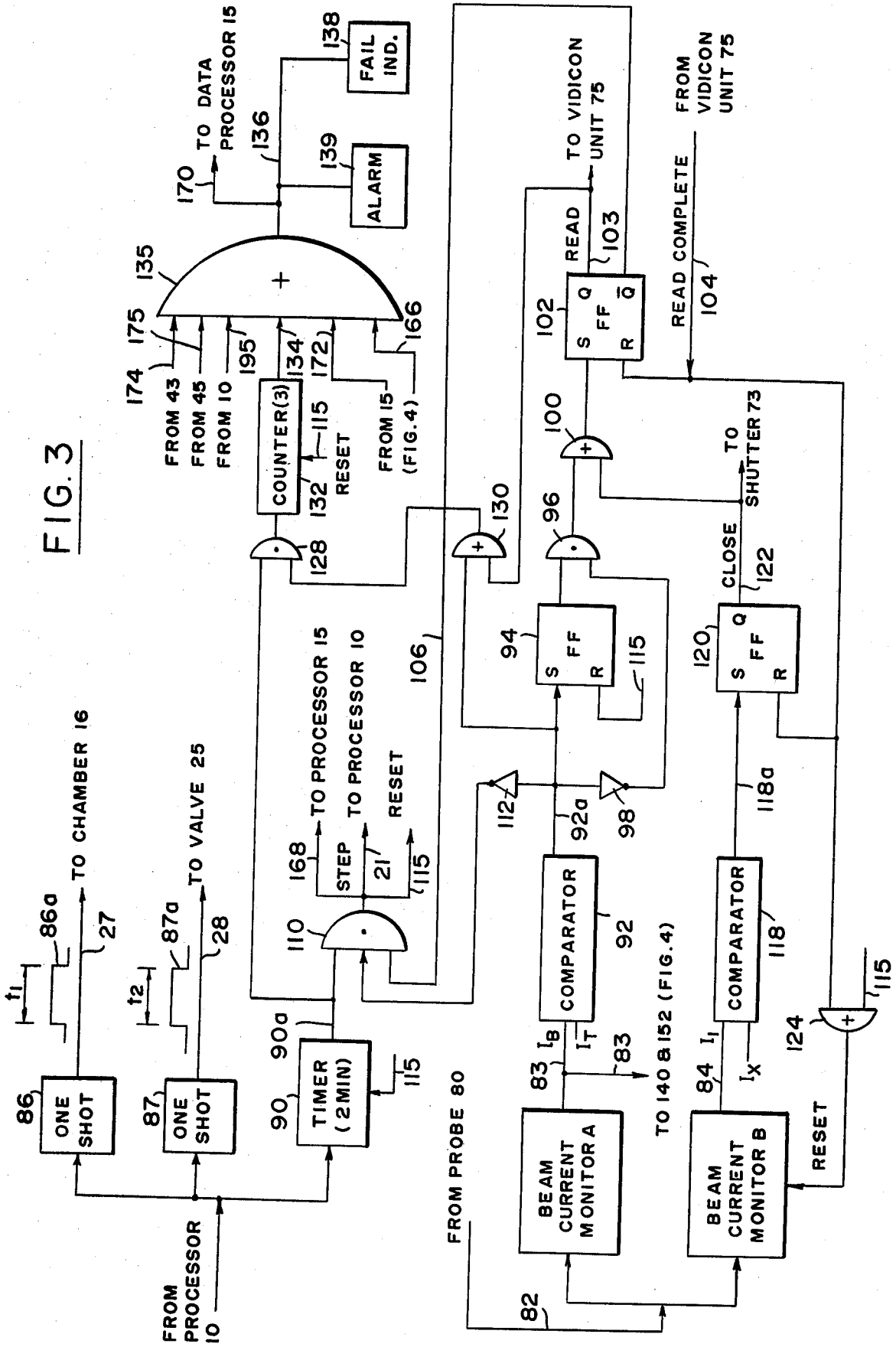

FIG. 4

FIG. 3



AUTOMATED MASS SPECTROMETER ANALYSIS SYSTEM

ORIGIN OF THE INVENTION

The invention described herein was made in part in the performance of work under a NASA contract and is subject to the provisions of Section 305 of the National Aeronautics and Space Act of 1958, Public Law 85-568 (72 Stat. 435; 42 USC 2457).

BACKGROUND OF THE INVENTION

1. Field of the Invention

The present invention generally relates to an automated analysis system and, more particularly, to an automated mass spectrometer analysis system finding particular utility, though not limited to, in automatically analyzing samples in biological matrices and providing an indication of identified sample components and their abundances.

2. Description of the Prior Art

The increasing realization of the molecular origin of health disease has led to a rapid expansion of our knowledge regarding body metabolism. Therefore, development of methods for the assay of a wide variety of complex organic compounds in biological matrices, such as blood or urine, is of interest to the clinical chemist. Presently, the relatively high cost per analyses and low sample throughput have made such analyses, in general, prohibitive for routine work.

For an analysis system to be of use to the biomedical researcher and clinical chemist it must meet a number of requirements. To be justified economically the system should operate automatically with a high degree of reliability, requiring minimum operator attention or maintenance, and have a high sample throughput, so that the cost per analysis can be held to a minimum. The system should be able to operate with very small sample volumes, be capable of determining a large number of compounds at very low level of concentration simultaneously, to conserve both time and sample. Although various systems for automatically or semi-automatically analyzing samples, present in blood or urine, have been proposed, all of them are in their early stages of development and to date do not meet the above enumerated requirements. Prior art systems which are in the early stages of development include the combination of a gas or liquid chromatograph, a mass spectrometer and a data processor, e.g., a computer. Among the problems which the prior art has not solved is the simultaneous conversion of the complete mass spectrometer output over a wide range of masses, into signals which the computer can use to provide an indication of the analyzed sample components and their abundances. Also, the automatic processing of samples, their successive introduction into a mass spectrometer and the overall control of such a system, so that it can operate automatically with minimum operator intervention and with a high degree of reliability have not been solved.

OBJECTS AND SUMMARY OF THE INVENTION

It is a primary object of the present invention to provide a new automated mass spectrometer analysis system.

Another object of the invention is to provide an analysis system in which small volumes of volatilizable samples or their characteristic volatilizable derivative

are analyzed automatically, to simultaneously determine each sample's components and their abundances with a high degree of accuracy, with minimum operator attention and with a high sample throughput rate.

These and other objects of the invention are achieved by providing a system which includes the following subsystems:

- a. a sample processor;
- b. a mass spectrometer;
- c. an electro-optical ion detector; and
- d. a data processor.

The various subsystems are under the control of a control unit which insures the proper automatic operation of the entire system. Briefly, the sample processor successively receives samples to be analyzed in separate identifiable cartridges. In the sample processor the samples are converted into their characteristic volatilizable derivative, hereinafter simply referred to as volatilizable samples. These volatilizable samples are successively volatilized and injected into the mass spectrometer. Therein, each volatilized sample is first ionized to form an ion beam which is then dispersed into separate ion beams, based on the mass-to-charge ratios of the ions. All the ion beams are focused simultaneously at a common focal plane. The electro-optical ion detector first converts the ion beams into separate electron beams which are used to produce separate images. Thereafter the separate images are converted into electrical signals, which are supplied to and processed in the data processor, which provides a list of identified components of the original sample and their abundances. The control unit is connected to the various subsystems so as to insure proper automatic operation of the system. In addition to monitoring the various voltages and currents supplied to various parts of the subsystems the control unit protects various parts of some of the subsystems from becoming oversaturated or damaged due to other than normally expected operating conditions. The control unit also controls the transfer of the electrical signals to the data processor. Upon completion of the transfer of the electrical signals to the data processor and after the sample has been determined to have been fully ionized the control system commands the transfer from the sample processor of another volatilizable sample to a volatilization chamber and its subsequent injection into the mass spectrometer for analysis.

The novel features of the invention are set forth with particularity in the appended claims. The invention will best be understood from the following description when read in conjunction with the accompanying drawings.

BRIEF DESCRIPTION OF THE DRAWINGS

FIG. 1 is an overall block diagram of the present invention;

FIGS. 2a-2c are diagrams useful in explaining some functions of an electro-optical ion detector, shown in FIG. 1; and

FIGS. 3 and 4 are logic diagrams of circuitry included in a control unit, shown in FIG. 1.

DESCRIPTION OF THE PREFERRED EMBODIMENTS

Attention is first directed to FIG. 1 which is a general block diagram of the present invention. Therein, a sample processor 10 is shown connected to a sample cartridge feeder 12. The latter receives sample to be analyzed in separate cartridges and sequentially feeds them into the sample processor. Each cartridge is assumed to

include a sample identification tag which is read by an optical reader 13 whose output is supplied to a data processor 15. The data processor stores the sample identification and after the sample has been analyzed and processed, as will be described hereinafter, the data processor outputs the results for each of the previously identified samples.

The function of the sample processor 10 is to automatically convert each incoming sample from feeder 12 into a volatilizable sample or its characteristic volatilizable derivative, which can be volatilized and thereafter injected into a mass spectrometer (MS) for analysis. This is achievable by sequentially positioning each of the incoming samples from feeder 12 at various chemical processing stations so as to convert each incoming sample into a corresponding volatilizable sample or its characteristic volatilizable derivative, which is contained in a separate cartridge.

The chemical processing which each sample undergoes in the sample processor 10 depends of course on the type of sample to be analyzed. One protocol, e.g., preparation of amino acids phenyl thiohydantoin is to detect amino acids in an incoming sample may include the following process steps:

1. drying the contents of each incoming cartridge with nitrogen under reduced pressures,
2. coupling of the amino acids with phenyl-iso-thiocyanate,
3. cyclization of the condensation product to the 2-amino-5 thiazolinone derivative, and
4. isomerization of the thiazolinone to the hydantoin, which represents the characteristic volatilizable derivative of amino acids.

Clearly, to analyze samples to detect other components different protocols will be employed in the sample processors, in order to convert each sample to be analyzed into its volatilizable state (or into its characteristic volatilizable derivative). For explanatory purposes, the output of the sample processor 10 can be thought of as a sequence of volatilizable samples contained in separate cartridges.

Many automated sample processors, often referred to as automated analyzers, are described in the literature and in various U.S. patents, and some are available commercially. Therefore, the sample processor 10 will not be described in further detail.

As shown in FIG. 1 the processor 10 is connected to a volatilization chamber 16 and to a control unit 20. The sample processor 10 is assumed to include a cartridge transfer mechanism (not shown). Upon receiving a signal representing a Step command from control unit 20 on line 21, the processor 10, by means of its transfer mechanism ejects a cartridge which was previously transferred into the chamber 16 with a volatilizable sample and transfers the next cartridge with a volatilizable sample in the sequence into the chamber 16. When the transfer is completed, the sample processor 10 provides a Transfer signal to the control unit 20 on line 22, thereby indicating that a new volatilizable sample is present in the volatilization chamber 16. For explanatory purposes, it is assumed that the sample processor 10 is capable of providing a new volatilizable sample for transfer to the chamber 16 once every few minutes, e.g., 2 minutes.

The volatilization chamber 16 is assumed to include a heater (not shown). As shown in FIG. 1, the chamber 16 is connected to a source of flushing gas 24 through a control valve 25. The control unit 20 upon receiving the

Transfer signal from the sample processor on line 22, which indicates that a new volatilizable sample has been transferred to the chamber 16, activates the heater of the chamber by means of a signal transmitted thereto via line 27. Consequently, the sample in chamber 16 is volatilized. In addition the control unit activates valve 25 to enable flushing gas from source 24 to flow into chamber 16 in order to flush out the volatilized sample therefrom into conduit 30 for injection into the ionization chamber 31 of a mass spectrometer (MS) 35. As shown in FIG. 1 valves 36 and 37 which are respectively controlled by their controllers 38 and 39 are interposed between the volatilization chamber 16 and the ionization chamber 31. The function of these valves will be described hereinafter in detail. At this point in the explanation it is sufficient to assume that these valves are used to control the rate of flow of the volatilized sample into the ionization chamber. A separator may be included in order to remove as much of the flushing gas from the mixture flowing to the ionization chamber, so that only the volatilized sample with a minimum amount of the flushing gas are injected into the ionization chamber.

For explanatory purposes, the MS 35 is assumed to be of the double focusing type with an electric sector 41 and a magnetic sector 42. It also includes a power source 43 which provides the necessary currents and voltages to the ionization chamber 31, the sectors 41 and 42, and to the MS pump 45. Such MSs are available commercially. For explanatory purposes the MS 35 is assumed to be of the Mattauch-Herzog type. As is appreciated by those familiar with the art of mass spectrometry in such an MS the ionized molecules in the ionization chamber 31 exit therefrom and pass through the electric sector 41, exiting the latter as a single ion beam with ions of a selected energy range. As the single ion beam enters the magnetic sector 42 it is separated into several beams in accordance with the ions' mass-to-charge ratios. Typically each ion beam contains ions of a different atomic mass unit (amu). All of the separated ion beams are focused at the MSs focal plane at the exit end of the magnetic sector 42.

In a conventional Mattauch-Herzog MS a photographic plate is placed at the focal plane and is exposed by the different ion beams. After exposure the photographic plate is developed. The points of exposure along the length of the plate are indicative of the components of the analyzed sample, and the levels of exposures, corresponding to the beams' intensities are indicative of the abundances of the various detected components.

Unlike the prior art in which the photographic plate is exposed by the dispersed ion beams at the focal plane, in accordance with the present invention an electro-optical ion detector (EOID) 50 is used to respond to the dispersed ion beams and automatically produce electrical signals which are indicative of the detected components of the analyzed samples and their abundances. The EOID 50 includes a microchannel electron multiplier array 52, which hereinafter will be referred to as MCA 52. The front end 53 of MCA 52 is located at the MS focal plane and its back end 54 is spaced apart from a phosphored plate 56. An MCA power source 58 applies a potential difference across the MCA 52, as well as a potential difference between the array back end 54 and the plate 56. The MCA 52 is positioned at the focal plane so that ions of separate beams enter simultaneously the microchannels of the MCA. Therein the

ions produce secondary electrons which exit the back end 54 in the form of separate electron beams which are accelerated to the plate 56, producing images thereon.

This aspect of the EOID 50 may further be explained in connection with FIGS. 2a and 2b. FIG. 2a is a view of the magnetic sector 42 as viewed from MCA 52. In FIG. 2a, numerals 60a and 60b designate the magnet's pole pieces which are spaced apart to form the magnetic gap 61 in which ion beams 62-67 are shown dispersed along an axis designated X, and focused at the focal plane. As is known, in a Mattauch-Herzog MS many ion groups are detectable simultaneously over a wide mass range 36:1, such as 28-1000 amu with good resolution of over 100 lines/mm. The ion beams are dispersible in the X axis over a length on the order of 360mm. The beams are of uniform height. Generally, a mask (not shown) is placed near the focal plane to reduce the beams' height to be less than the gap width. For explanatory purposes only a beam height of 0.4mm is assumed. In FIG. 2a, only six ion beams, dispersed in the X axis and designated by numerals 62-67 are shown. It is these ion beams which are converted by the MCA 52 into electron beams which in turn produce corresponding images 62a-67a on the phosphored plate 56, as shown in FIG. 2b. The intensity of each of these images is directly related to the intensity of its corresponding ion beam. With an assumed beam height of 0.4mm and a beam dispersion in the X axis of 360mm the phosphored plate should be at least 360mm long and at least 0.4mm wide. Images would be produced on the plate over an area of $0.4 \times 360 \approx 144\text{mm}^2$.

The EOID 50 includes optical fibers or rods designated by numeral 70 (see FIG. 1) and generally referred to as fiber optics. If desired the tips of the fiber optics 70 facing back end 54 of MCA 52 may be coated with phosphor to form a phosphor surface 56 instead of plate 56. Hereinafter however it will be referred to as the phosphored plate 56. EOID 50 also includes an optical arrangement 72, consisting of a shutter-diaphragm unit 73 and a lens 74. EOID 50 also includes a vidicon unit 75 with a target 76, which is typically square shaped. Briefly, the fiber optics 70 which are in contact with the plate 56 convert the long rectangularly shaped image format on the phosphored plate, as shown in FIG. 2b, into a square shaped format compatible with the target 76 dimensions. The images on the phosphored plate are transferred by the fiber optics to expose the target 76 through the optical arrangement 72 whose function will be described hereinafter. Assuming that the active target 76 is $12.7\text{mm} \times 12.7\text{mm} = 151\text{mm}^2$ incorporating 2.5×10^5 picture elements, 28 folds of the fiber optics are required to project the images in 28 different rows on the target surface. FIG. 2c is a simplified view of the target 76 with the images 62a-67a exposed thereon on several different lines.

As is appreciated a vidicon unit or camera is a device capable of converting the images which exposed its target into corresponding electrical signals by scanning the target. After the images have been transferred into corresponding electrical signals, generally referred to as Read operation, the target is effectively erased of the previously exposing images and is in condition to be exposed by new images.

In the present invention the vidicon unit 75 converts the images on its target 76 to electrical signals which are supplied to the data processor 15. Therein, the received electrical signals, which are related to the locations of the images on the target and their intensities, are pro-

cessed. The data processor 15 provides an output indicating the identified components of the analyzed sample, based on the images' locations, which correspond to ions of different amu values, and their abundances, based on the images' intensities.

From the foregoing it should be appreciated that in the system of the present invention volatilizable samples are successively volatilized and thereafter analyzed by MS 35 whose output, in the form of dispersed ion beams of different intensities, is indicative of the sample components and their abundances. These separate ion beams are simultaneously converted, first into electron beams and thereafter into corresponding photon images. These images expose the target of the vidicon unit, which converts the images into electrical signals which are supplied to the data processor for processing.

The data processor 15 is assumed to be of the type including a data storage capacitor, so that it can receive signals from the vidicon unit 75 as a result of an analyzed sample while still processing signals received from the analysis of a previously analyzed sample. However, the rest of the system is controlled so that once a volatilizable sample is introduced into chamber 16 it remains therein until the sample is analyzed and the electrical signals from the vidicon unit have been transferred to the data processor and the vidicon unit is ready for subsequent exposure before a new sample is introduced into chamber 16. Also since the amount of volatilizable sample may vary from one sample to another the system has to be controlled to protect particularly sensitive parts thereof from becoming adversely affected by such variations. For example, the ionization chamber 31 need be protected from an excessive rate flow of volatilized sample to be ionized so as not to become saturated with ionizable matter. The vidicon unit target 76 has to be protected from becoming overexposed and the MCA 52 has to be protected from excessive ion beam currents which may permanently damage it.

The various controls necessary for the proper automatic operation of the system are provided by the control unit 20, which will be described in connection with FIGS. 3 and 4. However, before describing the control unit, attention is briefly directed to FIG. 1 wherein an ion beam current probe 80 is shown positioned between the electric and magnetic sectors of MS 35. The function of this probe 80 is to measure the current in the total ion beam before it is dispersed into a plurality of beams in the magnetic sector 42. The probe 80 is shown connected to the control unit 20 by line 82. As shown in FIG. 3, line 82 is connected to the beam current monitors A and B, hereinafter simply referred to as monitors A and B.

Monitor A, in response to the signal from probe 80, provides an output on line 83 which is indicative of the instantaneous peak current in the ion beam. Monitor B on the other hand is of the integrating type, providing an output on line 84 which represents the integrated current from a point in time when the monitor B was reset. Such monitors are presently available and are often included in a commercial Mattauch-Herzog MS. In FIG. 3 the instantaneous beam current from monitor A is designated by I_B and the integrated current from monitor B by I_I . As will be described hereinafter the integrated current I_I is used to protect the vidicon target from overexposure.

As previously explained when a volatilizable sample is transferred to chamber 16 from processor 10 a Trans-

fer signal is sent by the sample processor 10 to unit 20 via line 22. The control unit 20 is assumed to include two one shots 86 and 87 and a timer or clock 90 each of which is activated by the Transfer signal on line 22. One shot 86 provides a pulse 86a of duration t_1 on line 27, thereby activating the heater in chamber 16 for the duration t_1 . One shot 86 on the other hand provides a pulse 87a of a duration t_2 on line 28, thereby switching valve 25 (see FIG. 1) for the duration t_2 to enable flushing gas to flow from source 24 to chamber 16. If desired the one shot 87 may be activated after one shot 86 by inserting a delay unit between one shot 87 and line 22. Such delay may be desirable to cause flushing gas to flow into chamber 16 only after some of the sample was already volatilized therein. Volatilization time on the order of 15 seconds or less can be achieved quite easily. As the sample is volatilized it flows from chamber 16 through conduit 30 to the ionization chamber 31 wherein it is ionized. The instantaneous beam current I_B is continuously monitored by comparing it with a threshold reference current I_T in a comparator 92. The output of the latter on line 92a is assumed to be true or high whenever $I_B \geq I_T$ and false or low when $I_B < I_T$.

As the ionization takes place and I_B increases, when $I_B \geq I_T$ line 92a goes high thereby setting a flip flop (FF) 94 so that its Q output, which is connected to an AND gate 96 goes high. As shown in FIG. 3 the comparator output line 92 is connected to an inverter 98 whose output is connected to the other input of AND gate 96. As long as $I_B \geq I_T$ the output of inverter 98 is low and therefore AND gate 96 is disabled. However, after the sample has been ionized and passed through sector 41 into sector 42, the beam current drops. When $I_B < I_T$ which is assumed to occur after the practically complete ionization of the sample, the output of inverter 98 goes high, thereby enabling gate 96, which through OR gate 100 sets FF102, so that its Q output on line 103 goes high. When line 103 goes high it represents a READ signal which is supplied to the vidicon unit 75.

In response thereto the Vidicon unit scans its target 76 in a manner well known in the art and converts the images thereon into electrical signals which are supplied to the data processor 15, as hereinbefore described. Upon completing the READ operation when the target surface has been sufficiently de-energized and is ready to be re-exposed a READ COMPLETE signal is supplied by the Vidicon unit 75 to the control unit on line 104. This signal resets FF102 so that its Q output on line 106 goes high. This line is shown as one input to a three-input AND gate 110. Another input to gate 110 is the output of an inverter 112 which goes high when $I_B < I_T$. The third input of gate 110 is the output of the timer or clock 90 which is connected to line 22.

The throughput of the system is primarily dependent on the rate at which the processor 10 can supply volatilizable samples to chamber 16. The volatilization of the sample, its ionization and dispersion in the MS as well as the time required by the vidicon camera to read its exposed target generally requires less than 1 minute. Assuming however that the rate at which volatilizable samples can be supplied by processor 10 is one sample every 2 minutes, timer 90 is a 2 minute timer, providing a pulse at the end of every 2 minutes. The first 2 minute period starts with the Transfer signal received on line 22, from sample processor 10.

At the end of the first 2 minute period timer 90 provides a pulse on its output line 90a which is connected as the third input to AND gate 110. The timer 90 is

assumed to be a binary counter which provides the end of 2-minute pulse when it is in an all zero state. If at this instant $I_B < I_T$ indicating that the entire sample has been analyzed so that the beam current I_B is less than the threshold current I_T , the output of inverter 112 is high. Also, if the vidicon camera has completed its READ operation line 106 is high. Consequently, gate 110 is enabled, providing a high output on line 21. When line 21 is high it represents the Step signal which is supplied to the sample processor 10, as hereinbefore explained. In response thereto the processor ejects the cartridge previously inserted in chamber 16 and transfers thereto a new volatilizable sample.

When AND gate 110 is enabled it also provides a high output on line 115 which is connected to line 21. When line 115 is high it resets various circuits in the control unit. Therefore line 115 can be thought of as the Reset line. Of the circuits described so far when Reset line 115 is high the timer 90 is reset through an OR gate 116. When the timer is reset it is driven to a zero time reference (an all zero state) and held therein until reactivated by a subsequent Transfer pulse on line 22. Also the Reset line 115 is connected to FF 94 to reset it.

Under normal operation in which the amount of sample to be analyzed does not exceed an expected amount the circuitry so far described, is used to control the automatic operation of the system. That is, it responds to a Transfer signal from the sample processor indicating that a volatilizable sample is in the volatilization chamber 16. It controls the sample volatilization and its flushing out by means of one shots 86 and 87. It monitors the ion beam current and controls the vidicon camera to convert the images on its target to electrical signals when the sample has been completely ionized ($I_B < I_T$) and after the completion of the Read operation and at the end of the 2-minute period from the Transfer signal, it commands the sample processor 10 by means of the Step signal on line 21 to supply a new volatilizable sample to the volatilization chamber 16.

However, the control unit includes additional circuitry to account for other than normal conditions. For example, let it be assumed that as a sample is ionized the integrated beam current I_I from monitor B exceeds a predetermined level I_X , which when related to the target 76 of the vidicon unit 75 represents the maximum desirable exposure of the target 76. To protect the target from overexposure the control unit includes a comparator 118 which provides a high output on line 118a when $I_I \geq I_X$. When line 118a goes high it sets FF120 so that its Q output on line 122 goes high. Line 122 is connected to the shutter of the shutter-diaphragm unit 73. When it goes high it closes the shutter, thereby interrupting the further exposure of the target 76 by images (light) directed thereto by the fiber optics 70. Also line 122 is connected to OR gate 100 which sets FF102 to provide the READ command to the vidicon unit 75. Thus, when the target 76 reaches maximum exposure it is read out even though the total sample ionization is not completed.

When the READ operation is completed by the vidicon unit 75 and the READ COMPLETE signal is received on line 104 FF120 is reset and the shutter is opened. Also monitor B is reset through OR gate 124. When monitor B is reset which also takes place under normal operating conditions when Reset line 115 goes high, it starts to integrate the beam current once more. It is thus seen that the control unit includes circuitry to prevent the vidicon target from overexposure. If, before

the complete ionization of the sample $I_T \cong I_T$ once more, the shutter would again be closed and the vidicon unit would perform a second Read operation. The electrical signals supplied to the data processor 15 from one or more such Read operations are combined in the processing of the signals for the sample which is being analyzed.

Hereinbefore it was assumed that under normal conditions the analysis of an average sample (excluding processing by data processor 15) requires less than 2 minutes. Consequently, for the average sample at the end of the first 2 minute period gate 110 is enabled and a new sample is transferred to the chamber 16. If however due to an unexpected large amount of sample or for some other unforeseen reason at the end of the first 2 minute period the analysis is not complete gate 110 is not enabled. The incomplete analysis may be indicated by the fact that the READ operation of the vidicon unit has not been completed, in which case FF102 is still in its set state and therefore line 106 is low, or $I_B \cong I_T$ in which case the output of inverter 112 is low.

In accordance with the present invention line 90a (output of timer 90) is connected to one input of an AND gate 128, and lines 92a and 103 are connected to an OR gate 130 whose output is connected to the second input of gate 128. If at the end of the first 2 minute period the analysis is not complete, namely either $I_B \cong I_T$ so that line 92a is high and/or the READ operation is not complete so that line 103 is high, gate 130 is enabled, enabling gate 128 to provide a pulse to a counter 132. For explanatory purposes counter 132 is assumed to count up to three. The first pulse from gate 128 advances the counter 132 to a count of one. If at the end of the second 2-minute period the analysis is still not complete a second pulse is provided by gate 128, incrementing the count in counter 132 to two. Then, if at the end of the third 2-minute period the analysis is still not complete a third pulse is supplied to the counter 132, causing it to reach a full count. Consequently, its output one line 134 is high enabling an OR gate 135 whose output on line 136 becomes high. When line 136 goes high it indicates a FAIL condition. Line 136 may be connected to illuminate a fail indicator 138 which is on the front panel of the control unit. Line 136 may also be used to activate an alarm 139 to alert an operator to inspect the system and determine the reason why the analysis was not completed in $2 \times 3 = 6$ minutes, when the expected normal analysis completion time is assumed to be 2 minutes.

If however, before the end of the second or third 2-minute period the analysis is completed both inputs to OR gate 130 are low, and therefore it does not enable AND gate 128 to clock the counter 132. Only AND gate 110 is enabled and a new sample is supplied. Under such conditions the counter 132 never reaches a full count of three and, therefore, the FAIL condition is not indicated. When the gate 110 is enabled the counter 132 which is connected to Reset line 115 is reset to a zero count. From the foregoing it is thus seen that in accordance with the present invention the control unit includes circuitry to enable the system to remain in its automatic mode and analyze a sample during a period up to 6 minutes, which is larger than the expected average analysis period of 2 minutes. Only when the analysis of the sample exceeds 6 minutes is the automatic operation interrupted, and an operator takes over to determine the reason for the FAIL condition.

As is appreciated by those familiar with the art the ionization chamber 31 of MS 35 has to be protected from becoming saturated by an excessive flow rate of the volatilized sample to be ionized. To this end valves 36 and 37 (see FIG. 1) are incorporated in the flow path of the volatilized sample from chamber 16 to the ionization chamber. The control unit includes a differential amplifier 140 (FIG. 3) to which the instantaneous beam current I_B from monitor A is supplied. Also supplied to amplifier 140 is a reference current I_P which is related to the maximum desirable flow rate of sample into the ionization chamber 16. The output of amplifier 140 on line 142 is supplied to controller 39 of the inlet valve 37 which is actually a throttle flow control valve. In operation as long as I_B is considerably less than I_P valve 37 is fully open. However, as the sample flow rate increases, and I_B approaches I_P the output of amplifier 140 on line 142 increases. It in turn activates controller 39 to activate valve 37 so as to restrict the sample flow rate there-through. Under most operating conditions valve 37 together with its controller 39 and the circuitry just described would be sufficient to prevent excessive sample flow rate to the ionization chamber, and thereby prevent its saturation. However, it is possible, though not likely, that even with the above described circuitry the flow rate may still be much higher than desirable and thereby damage the ionization chamber and possibly the MCA 52. The damage to the latter may result from extremely intense dispersed ion beams or over-pressure of the MS, produced due to the extremely excessive flow rate of volatilizable sample into the ionization chamber 31.

In order to prevent such undesirable conditions from occurring valve 37 and its controller 38 together with circuitry to be described are included in the system. Valve 37 is assumed to be a two-position valve. In one position referred to as the Normal position sample from chamber 16 flows through the valve 36 to valve 37. In the other valve position, referred to as the Vent position sample from chamber 16 flows through the valve 36 and is vented through a vent 150 (see FIG. 1). Thus, in this position the flow of volatilized sample to the ionization chamber is completely terminated.

In the control unit the instantaneous beam current I_B is compared with a reference current I_{MAX} (see FIG. 4) in a comparator 152. I_{MAX} which is greater than I_P represents a maximum beam current which if exceeded indicates extremely high sample flow rate which may damage the ionization chamber and/or the MCA. In operation, when $I_B \cong I_{MAX}$ the output of comparator 152 on line 154 goes high, thereby triggering a one shot 155. The latter, upon being triggered, provides an output pulse 156 of duration t_3 on its output line 158 which is connected to the input of a counter 160 assumed to be a count-by-two counter. The pulse 156 increments the count in counter 160 from 0 to 1. More importantly, output line 158 is connected via line 162 and the valve controller 38. The latter upon sensing the leading edge of pulse 156 switches valve 36 to the Vent position, thereby terminating the flow of sample to the ionization chamber. During the duration t_3 of pulse 156 the volatilized sample is vented through vent 150. Also connected to output line 158 is a line 164 which is connected to the MCA power source 58. The leading edge of pulse 156 deactivates power source 58 thereby removing the potentials applied to the MCA 52 and the phosphored plate 56. The removal of these potentials protects the

MCA from any damage due to excessively intense dispersed ion beams.

At the end of the pulse period t_3 power source 58 is reactivated and controller 38 switches valve 36 back to the normal position. If however despite the venting of part of the sample through vent 150, I_B is still equal or greater than I_{MAX} , output line 154 remains high and the one shot 155 provides a second pulse on its output line 158. This second pulse increments the count in counter 160 to two, causing its output on line 166 to go high. Since line 166 is connected as one input to OR gate 135 the latter is enabled, and provides the FAIL condition signal to indicator 138 and/or alarm 139. Clearly, if desired counter 150 may be other than a count-by-two counter so that more than one sample venting cycle may take place before the FAIL condition is produced.

If however at the end of the first period t_3 , $I_B < I_{MAX}$, the output line 154 of comparator 152 is low and therefore one shot 155 is not retriggered. Consequently, the count in counter 160 remains one. The counter is reset via line 115 when AND gate 110 is enabled, and a STEP command for a new sample is supplied to the sample processor 10.

As shown in FIG. 1 the control unit 20 is also connected to the data processor 15. Whenever gate 110 is enabled and a STEP command is produced the enabled output of gate 110 is supplied to the data processor 15 via line 168 to indicate to the processor 15 that the signals received from the vidicon unit 75, since a previous instant in time when line 168 was high, are from one sample and that a new sample is being introduced into chamber 16. Also, whenever a FAIL condition arises the processor 15 is informed thereof via line 170 which is connected to OR gate 135. Based on the prior identifications of the samples as they are fed into the sample processor 10 the processor determines which sample is in the system while the failure occurred and which samples are still in the sample processor 10. Furthermore, any failure in the data processor 15 may be fed to the control unit 20 via line 172 to activate OR gate 135, indicating a FAIL condition which alerts the operator.

As is appreciated by those familiar with MSs, commercially available MSs include the power units which supply the required voltages and current to the ionization chamber to the electric and magnetic sectors and the required pumps. The various voltages and currents are generally indicated on dials in a display panel. The latter also includes control knobs and/or switches by means of which an operator may independently vary the voltages and currents. Also, in many MSs power or vacuum failures are automatically sensed to shut off the appropriate power supplies and thereby prevent damage to the MS.

In accordance with the present invention any failure automatically detected in the MS is supplied to OR gate 135 of the control unit to indicate the FAIL condition.

In FIGS. 1 and 3 lines 174 and 175 are assumed to supply a fail-indication condition from power source 43 and the MS pumps 45 respectively. Furthermore, the control unit is assumed to include circuitry to monitor the various voltages and currents supplied by power source 43 in MS 35, and the voltages supplied by power source 58 to MCA 52 and the phosphored plate 56. Based on the monitored voltages and currents they are automatically adjusted to optimal preselected levels. Some of the adjustments may occur on a continual basis, while others may take place only between analysis steps, namely while one cartridge which has previously

contained an analyzed sample is ejected from chamber 16 and a second cartridge with a new volatilizable sample is transferred thereto.

It should be appreciated that various known circuits including comparators, differential amplifiers and servo motors may be used by those familiar with the art in many different arrangements to monitor and control the power sources. Therefore, providing specific details for power source monitoring and control is not believed to be necessary. In FIG. 4 block 180 represents a power source monitor and control unit. The input lines 181 to unit 180 represent the lines through which the various voltages and currents provided by the power sources 43 and 58 are supplied to block 180 for monitoring. Based on the monitored voltages and currents, control signals are supplied by unit 180 on lines 182 to sources 43 and 58 to adjust, whenever necessary, the voltages and current to the preselected optimal levels.

As an example, and not for purposes of limiting the invention thereto, unit 180 may include three differential amplifiers 191, 192 and 193 (see FIG. 4) which are respectively supplied with signals corresponding to the electron current, designated I_Z , the accelerating voltage, designated V_A and the ionizing voltage, designated V_I which the MS power source 43 assumed to supply to the ionization chamber 31. In amplifier 191, I_Z is compared with an optimal electron current I_O and when I_Z deviates from I_O the output of the amplifier 191 is other than zero. It is supplied to power source 43 to adjust I_Z until the output of amplifier 191 is zero thereby indicating that $I_Z = I_O$. Similarly, V_A may be compared with an optimal accelerating voltage V_A' , and the output of amplifier 192 may be used in power source 43 to adjust the accelerating voltage until $V_A = V_A'$. Likewise, V_I may be compared with an optimal ionization voltage V_I' , and the output of amplifier 193 may be used to control source 43 so that V_A becomes equal to V_A' .

Hereinbefore it was assumed that sample processor 10 includes its separate control unit which in addition to responding to the STEP signal from control unit 20 and providing the TRANSFER signal thereto, also controls the automatic processing of the samples fed thereto from feeder 12, so that each processed sample is in its volatilizable state or is converted into its characteristic volatilizable derivative. Any fail condition in the sample processor may also be supplied to OR gate 135 via line 195 and thereby alert the operator. In FIG. 1 the volatilization chamber 16 is shown as a separate unit. In practice it can be part of the processor 10 as its output stage or may be regarded as the input stage of the MS 35.

Although the invention has been described in connection with the sample processor 10 and the data processor 15, it is not intended to be limited thereto. The invention may also be viewed as comprising of the volatilization chamber 16, the MS 35, the EOID 50 and the control unit 20. When so viewed the sample processor 10 can be thought of as an input stage which contains a sequence of volatilizable samples in separate cartridges. In response to a STEP signal the input stage ejects a previously inserted cartridge from chamber 16 and transfers the first sample-containing cartridge in the sequence into the chamber 16. The identification on the cartridge may be read by optical reader 13 just prior to the cartridge transfer into the chamber 16. Data processor 15 may be viewed as an output stage to which electrical signals are supplied. The signals are indicative of the components of the sample which is being analyzed and their abundances.

Although particular embodiments of the invention have been described and illustrated herein, it is recognized that modifications and variations may readily occur to those skilled in the art and consequently, it is intended that the claims be interpreted to cover such modifications and equivalents.

What is claimed is:

1. An analysis system comprising:

volatilization chamber means adapted to volatilize a sample supplied thereto;

mass spectrometer means to which said volatilized sample is applied for generating therefrom a single ion beam and thereafter separate said single ion beam into a plurality of ion beams simultaneously focused at a common focal plane;

detection means for converting said separate ion beams into electrical signals in response to a Read signal;

output means for receiving said electrical signals; and system control means for generating said Read signals as a function of the current of said single ion beam.

2. The system as described in claim 1 wherein said detection means include means for converting said ion beams into images and means responsive to said Read signal for converting said images into electrical signals.

3. The system as described in claim 1 wherein said control means include means for detecting the current level of said single ion beam and for generating said Read signal only after the single ion beam current level drops below a preselected threshold current level.

4. The system as described in claim 3 further including input means for providing a succession of volatilizable samples, a volatilizable sample being provided every n minutes, said input means including transfer means responsive to a Step signal from said control means for transferring a volatilizable sample, provided by said input means, into said volatilization chamber means, and for supplying a Transfer signal to said control means upon the completion of the transfer of a volatilizable sample to said volatilization chamber means, said control means including means responsive to said Transfer signal for activating said volatilization chamber means to volatilize the sample last transferred thereto from said input means, said detection means providing a Read Complete signal to said control means upon the completion of the conversion of said ion beams into electrical signals, and said control means further including means for providing said Step signal only if said Read Complete signal is received prior to the end of a period of mn minutes from the time said Transfer signal has been received, where m is an integer other than zero and not greater than an integer f .

5. The system as described in claim 4 wherein said detection means include means for converting said ion beams into images and means responsive to said Read signal for converting said images into electrical signals and for providing said Read Complete signal upon the completion of the conversion of said images into the electrical signals.

6. An analysis system comprising:

volatilization chamber means adapted to receive a volatilizable sample for volatilizing said sample therein;

mass spectrometer means for ionizing a volatilized sample supplied thereto to form a single ion beam, and for dispersing ions in said single ion beam to

simultaneously produced separate ion beams focused at a common focal plane;

coupling means between said volatilization chamber means and said mass spectrometer means for providing a path for the sample volatilized in said volatilization chamber means to said mass spectrometer means;

ion detection means for converting said ion beams focused at said focal plane into separate images, said ion detection means including images-to-electrical signals converting means, the later including a target exposable by said separate images and including means responsive to a Read signal for converting the images on said target into electrical signals;

output means for receiving the electrical signals from said converting means; and

system control means including probe means for detecting the level of the ion current in said single ion beam and for generating said Read signal as a function of said single ion beam current level.

7. The system as described in claim 6 further including input means for providing a succession of volatilizable samples, a volatilizable sample being provided every n minutes, said input means including transfer means responsive to a Step signal from said control means for transferring a volatilizable sample provided in said input means into said volatilization chamber means and for supplying a Transfer signal to said control means upon the completion of the transfer of a volatilizable sample to said volatilization chamber means, said control means including means responsive to said Transfer signal for activating said volatilization chamber means to volatilize the sample last transferred thereto from said input means, said converting means providing a Read Complete signal to said control means upon the completion of the conversion of said images into electrical signals and said control means further including means for providing said Step signal to said input means only if said Read Complete signal is received by said control means prior to the end of a period of mn minutes from the time said Transfer signal has been received, where m is an integer other than zero and not greater than an integer f .

8. The system as described in claim 7 wherein said control means include means for indicating a fail condition whenever at the end of f/n minutes from the time said Transfer signal has been received either the single ion beam current level is not less than a preselected threshold level or the Read Complete signal has not been received from said converting means.

9. The system as described in claim 7 wherein said system further includes a source of flushing gas and said control means include means for controlling the flow of the flushing gas from said source to said volatilizable chamber means for a preselected period after said Transfer signal is received, in order to flush the volatilized sample in said volatilization chamber means to said mass spectrometer means through said coupling means.

10. The system as described in claim 6 wherein said coupling means includes a first flow control valve and said control means includes means for controlling the flow rate of said volatilized sample from said volatilization chamber to said mass spectrometer means through said first flow control valve as a function of the single ion beam current level, definable as I_p , and a preselected reference current level, definable as I_r , where I_p repre-

sents an optimal maximum desirable ion beam current level.

11. The system as described in claim 10 wherein said coupling means further includes a second flow control valve, and said control means include means for comparing said ion beam current level I_B with a reference current level, definable as I_{MAX} , where $I_{MAX} > I_P$, and for switching said second valve for a preselected period to a vent position in which volatilized sample is vented through said second valve and inhibited from flowing to said mass spectrometer means whenever $I_B \cong I_{MAX}$.

12. The system as described in claim 11 further including input means for providing a succession of volatilizable samples, a volatilizable sample being provided every n minutes, said input means including transfer means responsive to a Step signal from said control means for transferring a volatilizable sample provided in said input means into said volatilization chamber means and for supplying a Transfer signal to said control means upon the completion of the transfer of a volatilizable sample to said volatilization chamber means, said control means including means responsive to said Transfer signal for activating said volatilization chamber means to volatilize the sample last transferred thereto from said input means, said converting means providing a Read Complete signal to said control means upon the completion of the conversion of said images into electrical signals and said control means further including means for providing said Step signal to said input means only if said Read Complete signal is received by said control means prior to the end of a period of mn minutes from the time said Transfer signal has been received, where m is an integer other than zero and not greater than an integer f .

13. The system as described in claim 12 wherein said control means include means for indicating a fail condition whenever at the end of fn minutes from the time said Transfer signal has been received either the single ion beam current level is not less than a preselected threshold level or the Read Complete signal has not been received from said converting means.

14. The system as described in claim 13 wherein said ion detection means include microchannel electron multiplier means, and power means coupled thereto for converting said separate ion beams at said focal plane into separate electron beams, and means exposable to said electron beams for producing images corresponding thereto, said control means include means for activating the means in said control means which indicate the fail condition whenever said second valve is switched to said vent position x times after a Transfer is received by said control means and before a Step signal is supplied thereby, x being an integer not less than one.

15. The system as described in claim 14 including means in said control means for deactivating said power means coupled to said microchannel electron multiplier means when said second valve is switched to said vent position.

16. The system as described in claim 6 wherein said control means include means for generating said Read signal when said single ion beam current level, definable as I_B , falls below a preselected threshold current level, definable as I_T after I_B has prior thereto exceeded I_T .

17. The system as described in claim 16 wherein said coupling means includes a first flow control valve and said control means includes means for controlling the flow rate of said volatilized sample from said volatilization chamber to said mass spectrometer means through

said first flow control valve as a function of the single ion beam current level, definable as I_B , and a preselected reference current level, definable as I_P , where I_P represents an optimal maximum desirable ion beam current level.

18. The system as described in claim 17 further including input means for providing a succession of volatilizable samples, a volatilizable sample being provided every n minutes, said input means including transfer means responsive to a Step signal from said control means for transferring a volatilizable sample provided in said input means into said volatilization chamber means and for supplying a Transfer signal to said control means upon the completion of the transfer of a volatilizable sample to said volatilization chamber means, said control means including means responsive to said Transfer signal for activating said volatilization chamber means to volatilize the sample last transferred thereto from said input means, said converting means providing a Read Complete signal to said control means upon the completion of the conversion of said images into electrical signals and said control means further including means for providing said Step signal to said input means only if said Read Complete signal is received by said control means prior to the end of a period of mn minutes from the time said Transfer signal has been received, where m is an integer other than zero and not greater than an integer f .

19. The system as described in claim 18 wherein said control means include means for indicating a fail condition whenever at the end of fn minutes from the time said Transfer signal has been received either I_B is not less than I_T or the Read Complete signal has not been received from said converting means.

20. The system as described in claim 19 wherein said ion detection means include microchannel electron multiplier means, and power means coupled thereto for converting said separate ion beams at said focal plane into separate electron beams, and means exposable to said electron beams for producing images corresponding thereto, said control means include means for activating the means in said control means which indicate the fail condition whenever said second valve is switched to said vent position x times after a Transfer is received by said control means and before a Step signal is supplied thereby, x being an integer not less than one.

21. The system as described in claim 20 including means in said control means for deactivating said power means coupled to said microchannel electron multiplier means when said second valve is switched to said vent position.

22. The system as described in claim 6 wherein said converting means comprise vidicon means including said target which is exposed by said images and including means responsive to said Read signal for converting said images into electrical signals.

23. The system as described in claim 22 further including input means for providing a succession of volatilizable samples, a volatilizable sample being provided every n minutes, said input means including transfer means responsive to a Step signal from said control means for transferring a volatilizable sample provided in said input means into said volatilization chamber means and for supplying a Transfer signal to said control means upon the completion of the transfer of a volatilizable sample to said volatilization chamber means, said control means including means responsive to said Transfer signal for activating said volatilization

chamber means to volatilize the sample last transferred thereto from said input means, said vidicon means providing a Read Complete signal to said control means upon the completion of the conversion of said images into electrical signals and said control means further including means for providing said Step signal to said input means only if said Read Complete signal is received by said control means prior to the end of a period of mn minutes from the time said Transfer signal has been received, where m is an integer other than zero and not greater than an integer f .

24. The system as described in claim 23 wherein said system further includes a source of flushing gas and said control means include means for controlling the flow of the flushing gas from said source to said volatilizable chamber means for a preselected period after said Transfer signal is received, in order to flush the volatilized sample in said volatilization chamber means to said mass spectrometer means through said coupling means.

25. The system as described in claim 24 wherein said coupling means includes a first flow control valve and said control means includes means for controlling the flow rate of said volatilized sample from said volatilization chamber to said mass spectrometer means through said first flow control valve as a function of the single ion beam current level, definable as I_B , and a preselected reference current level, definable as I_P , where I_P represents an optimal maximum desirable ion beam current level.

26. The system as described in claim 25 wherein said control means include means for indicating a fail condition whenever at the end of fn minutes from the time said Transfer signal has been received either the single ion beam current level is not less than a preselected threshold level or the Read Complete signal has not been received from said converting means.

27. The system as described in claim 26 wherein said coupling means further includes a second flow control valve, and said control means include means for comparing said ion beam current level I_B with a reference current level, definable as I_{MAX} , where $I_{MAX} < I_P$, and for switching said second valve for a preselected period to a vent position in which volatilized sample is vented through said second valve and inhibited from flowing to said mass spectrometer means whenever $I_B \geq I_{MAX}$.

28. The system as described in claim 27 wherein said ion detection means include microchannel electron multiplier means, and power means coupled thereto for converting said separate ion beams at said focal plane into separate electron beams, and means exposable to said electron beams for producing images corresponding thereto, said control means include means for activating the means in said control means which indicate the fail condition whenever said second valve is switched to said vent position x times after a Transfer is received by said control means and before a Step signal is supplied thereby, x being an integer not less than one.

29. The system as described in claim 28 including means in said control means for deactivating said power means coupled to said microchannel electron multiplier means when said second valve is switched to said vent position.

30. The system as described in claim 22 wherein said control means include means for generating said Read signal when said single ion beam current level, definable as I_B , falls below a preselected threshold current level, definable as I_T after I_B has prior thereto exceeded I_T .

31. The system as described in claim 30 further including input means for providing a succession of volatilizable samples, a volatilizable sample being provided every n minutes, said input means including transfer

means responsive to a Step signal from said control means for transferring a volatilizable sample provided in said input means into said volatilization chamber means and for supplying a Transfer signal to said control means upon the completion of the transfer of a volatilizable sample to said volatilization chamber means, said control means including means responsive to said Transfer signal for activating said volatilization chamber means to volatilize the sample last transferred thereto from said input means, said vidicon means providing a Read Complete signal to said control means upon the completion of the conversion of said images into electrical signals and said control means further including means for providing said Step signal to said input means only if said Read Complete signal is received by said control means prior to the end of a period of mn minutes from the time said Transfer signal has been received, where m is an integer other than zero and not greater than an integer f .

32. The system as described in claim 31 wherein said system further includes a source of flushing gas and said control means include means for controlling the flow of the flushing gas from said source to said volatilizable chamber means for a preselected period after said Transfer signal is received, in order to flush the volatilized sample in said volatilization chamber means to said mass spectrometer means through said coupling means.

33. The system as described in claim 32 wherein said coupling means includes a first flow control valve and said control means includes means for controlling the flow rate of said volatilized sample from said volatilization chamber to said mass spectrometer means through said first flow control valve as a function of the single ion beam current level, definable as I_B , and a preselected reference current level, definable as I_P , where I_P represents an optimal maximum desirable ion beam current level.

34. The system as described in claim 33 wherein said control means include means for indicating a fail condition whenever at the end of fn minutes from the time said Transfer signals has been received either I_B is not less than I_T or the Read Complete signal has not been received from said converting means.

35. The system as described in claim 34 wherein said coupling means further includes a second flow control valve, and said control means include means for comparing said ion beam current level I_B with a reference current level, definable as I_{MAX} , where $I_{MAX} > I_P$, and for switching said second valve for a preselected period to a vent position in which volatilized sample is vented through said second valve and inhibited from flowing to said mass spectrometer means whenever $I_B \geq I_{MAX}$.

36. The system as described in claim 35 wherein said ion detection means include microchannel electron multiplier means, and power means coupled thereto for converting said separate ion beams at said focal plane into separate electron beams, and means exposable to said electron beams for producing images corresponding thereto, said control means include means for activating the means in said control means which indicate the fail condition whenever said second valve is switched to said vent position x times after a Transfer is received by said control means and before a Step signal is supplied thereby, x being an integer not less than one.

37. The system as described in claim 35 including means in said control means for deactivating said power means coupled to said microchannel electron multiplier means when said second valve is switched to said vent position.

* * * * *