

Population Analysis: Communicating in Context

Providing accommodation to a widely varying user population presents a challenge to engineers and designers. It is often even difficult to quantify who is accommodated and who is not accommodated by designs, especially for equipment with multiple critical anthropometric dimensions. An approach to communicating levels of accommodation referred to as “population analysis” applies existing human factors techniques in novel ways. This paper discusses the definition of population analysis as well as major applications and case studies. The major applications of population analysis consist of providing accommodation information for multivariate problems and enhancing the value of feedback from human-in-the-loop testing. The results of these analyses range from the provision of specific accommodation percentages of the user population to recommendations of design specifications based on quantitative data. Such feedback is invaluable to designers and results in the design of products that accommodate the intended user population.

INTRODUCTION

The importance of accommodating the entire range of expected users for any system is widely accepted, but understanding whether the desired accommodation is actually achieved is not always simple. Human factors practitioners must find ways to communicate issues to equipment designers in order to alleviate these issues.

Population analysis, which applies existing human factors methodologies in novel ways, represents an approach that places human data into the context of the population from which it is drawn. This paper will discuss the definition and importance of population analysis along with applications and case studies.

DEFINITION OF POPULATION ANALYSIS

Population analysis places human data into the context of the entire user population. This may consist of defining test subjects based on comparisons to the extremes of the expected population, or it may consist of comparing hardware dimensions against a large database of potential users. Whichever approach, the end result is a better definition of subject accommodation. By providing context to hardware dimensions, more information is conveyed to designers.

MAJOR APPLICATIONS

Analysis of multivariate problems

Through analyzing multiple variables simultaneously, it is possible to take understanding beyond one-dimensional percentiles. It is relatively simple to place data into context for one-dimensional cases. For example, the height of a doorway can be based on stature. The door should be designed such that the tallest expected user can walk through upright. If the height of the doorway is equivalent to 90th percentile male stature, it can be deduced that approximately 10 percent of males in that population will experience difficulty in traversing through the doorway.

However, it may also be necessary to determine an appropriate width for the doorway. This should be based on anthropometry as well, with the largest expected bidentoid breadth as an example of a possible appropriate minimum width. If the width of the doorway is 90th percentile male bidentoid width, approximately 10 percent of the male population will not be accommodated due to this dimension.

The trouble in defining accommodation arises when the height and width dimensions are taken into account simultaneously. For instance, combining the two previous examples, since stature and bidentoid breadth are not highly correlated it would be inaccurate to conclude that 10% of the total population cannot use the doorway. The group of individuals that is not accommodated due to stature may share some members with the group that is not accommodated due to bidentoid breadth, and thus somewhere between 10 percent and 20 percent of the population will not be accommodated.

Through analysis of a sample database of population anthropometry, it is possible to determine a reasonable estimate of the percentage of the population that will not be accommodated in this simple example of a multivariate problem. A similar application using a real-world case study will be discussed more in-depth later on in the paper.

Enhancement of human-in-the-loop testing

Subject feedback becomes more valuable when it is examined within the context of the population as a whole. For example, subjective performance ratings can serve as valuable tools, and a subject may be asked to rate the difficulty of walking through the doorway suggested in the previous example. The subject may indicate that the doorway was completely acceptable. Perhaps a group of 10 subjects walks through the doorway and agrees that the doorway is completely acceptable.

Taken alone, these results might encourage designers to believe that the dimensions are appropriate for the population as a whole. However, it is imperative to consider the statures and bidentoid breadths of the subjects who provided these ratings. If the largest stature tested was 55th percentile male

and the largest bideltoid breadth tested was 60th percentile male, the conclusion that the dimensions were acceptable for larger subjects based on all positive ratings would be unfounded.

On the other hand, if the largest subjects tested met or exceeded the largest expected user, the positive user feedback could be valuable. This would indicate that the extremes of the population were in fact tested, and thus the feedback represents the predicted worst-case scenario.

Even for simple pass-fail tests, such as observing whether a subject is able to walk through the doorway without colliding with the frame, comparing the subject's dimensions to the user population's dimensions brings power to the evaluation that would otherwise not be present.

CASE STUDIES

In order to examine specific examples of applications of population analysis, several case studies are examined. These case studies were performed at NASA-Johnson Space Center (JSC) and were associated with the development of hardware for the Constellation Program, which seeks to regain a human presence on the moon. Population analysis was performed by staff of the Anthropometry and Biomechanics Facility.

Lunar Lander Vehicle Design

The Altair ascent stage will carry astronauts between the Orion capsule and the surface of the moon. JSC's Habitability Design Center built a low-fidelity mock-up in order to test the interior dimensions of the vehicle. The goal of testing was to determine whether the volume provided adequate space for tasks such as accessing storage and using vehicle controls while wearing a spacesuit.

The vehicle is intended to carry four astronauts wearing spacesuits. It was not feasible to test a large number of subjects or a wide range of subject sizes because the only available planetary spacesuits are prototypes. One subject was tested wearing the Mark III prototype suit, and one subject was tested wearing the Advanced Crew Escape Suit (ACES), which is a launch and re-entry suit in use for the Shuttle program (see Figure 1). In addition, a

person wearing a non-functional simulated Mark III suit stood at one control station in order for the subjects wearing the actual suits to judge access to controls.



Figure 1. Left: Subject wearing Mark III suit uses rear hatch of vehicle; Right: Subject wearing ACES accesses stowage

Video data was collected to record collisions and other potential problems while the two subjects separately performed tasks. The subject wearing the ACES, which is a less cumbersome suit, experienced few difficulties, so further analysis focused on the subject wearing the larger Mark III suit.

A set of critical anthropometric dimensions was selected, including dimensions such as foot length, bideltoid breadth, chest depth, and forearm-forearm breadth. The subject's minimally clothed dimensions were compared to the Constellation Program's anthropometric database, with percentile values and absolute differences between the subject and the maximum expected astronaut dimensions provided.

This enabled better analysis of the results. For example, the subject's bideltoid breadth and forearm-forearm breadth were smaller than the average male values. However, the subject still collided at the upper and lower arm with the person wearing the mock-up suit while attempting to access controls (see Figure 2). The subject did not represent an extreme case, so it is probable that a large number of subjects would experience the same difficulty.



Figure 2. Mark III subject collides with simulated Mark III suit while attempting to access vehicle controls

Further analysis considered a hypothetical case of multiple large males occupying the volume of the vehicle. Mathematical analysis enabled predictions concerning the fit of males with maximal critical dimension values (see Figure 3).

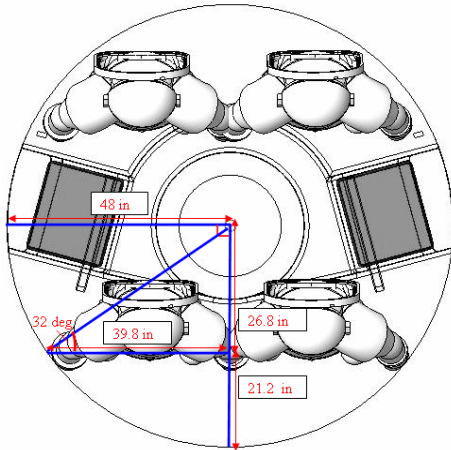

Figure 3. Maximal male critical dimensions displayed in an overhead view with vehicle dimensions.

The simple step of placing the single subject's data into the context of the population added significantly to the value of the results of this analysis. Bideltoid breadth and forearm-forearm breadth were examined in more detail due to the fact that the subject experienced collisions during tasks for which the dimensions were critical. The subject does not represent the extremes in these dimensions, and bringing this to the attention of designers highlights the potential for problems with larger individuals. Such analysis is often important

in settings for which it is unrealistic to test large pools of subjects.

Suit Design Critical Dimensions

Constellation Program hardware design requirements as defined in the Human-Systems Integration Requirements (HSIR, 2007) currently include the accommodation of individuals from 1st percentile female to 99th percentile male in the standardized database for a set of critical design dimensions.

The set of critical design dimensions was agreed upon between human factors engineers and vehicle and spacesuit designers. Though cockpit designers indicated that it was technically feasible to accommodate the full range of subjects, spacesuit designers initially indicated that accommodation of the full range was not feasible and provided a list of body sizes they considered to be reasonable.

The information provided by suit designers consisted of minimum and maximum body dimensions that they felt confident accommodating. Though designers understood that the entire range of the astronaut population would not be accommodated, further analysis enabled a more thorough grasp of the need to expand the range of suit sizes available.

Analysis consisted of filtering the entire population database, based on the ANSUR military database (Gordon et al, 1988), through the minimum and maximum values provided by suit designers. Fourteen dimensions were provided, with varying ranges of minimum and maximum values. Any subject in the database who fell outside of the range for one dimension was excluded from the pool of subjects for additional dimensions, resulting in a final list of subjects falling within the range for all critical dimensions.

This is another example of a simple analysis that provided powerful results. Examining the results of the initial population analysis against the standard database revealed that female accommodation was unacceptable, and male accommodation was less than anticipated (see Figure 4).

Deleted: attempted

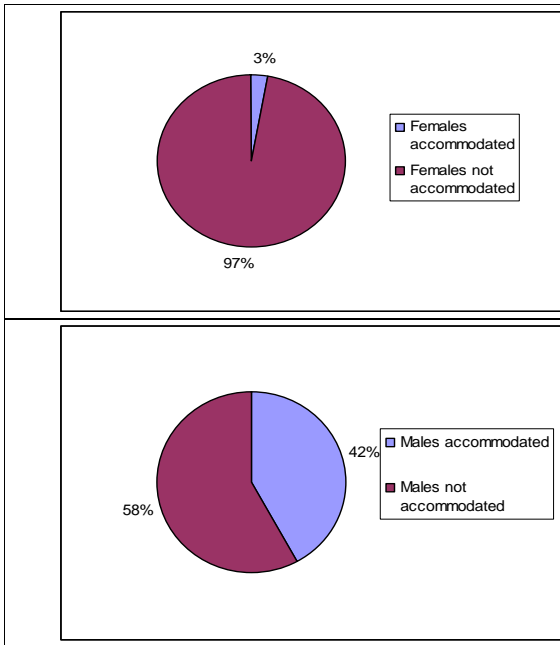

Figure 4. Accommodation rates of females and males based on dimensions provided by suit designers

Illustrating the levels of accommodation through the population analysis added significant value to the communication between human factors engineers and suit designers, encouraging the suit designers to rethink some of the limitations they previously considered to be in place. Ultimately, suit designers determined that it is feasible to design for 1st percentile female to 99th percentile male for each critical dimension. If this is achieved, accommodation levels will raise to slightly better than 90 percent for each gender.

SUMMARY AND CONCLUSIONS

These examples illustrate simple ways in which anthropometric data can be communicated in order to place information into context. The communication between human factors practitioners and design engineers is critical. At NASA, human factors practitioners have the opportunity to provide input early in the design stages. It is essential to take full advantage of that opportunity through clearly communicating

potential design issues and providing solid justification for recommendations.

Defining the anthropometry of a human subject against the population provides additional value to human-in-the-loop testing, especially when a very small number of subjects are available. It is possible to interpret the results of tests with more clarity through understanding whether the subject represents extreme values in critical anthropometry dimensions.

Providing information pertaining to accommodation levels brings important information to the table when human factors issues are weighed against other design considerations. It may not always be feasible to accommodate the full desired range of the population within budget, but quantifying accommodation levels enables engineers and managers to understand the impact of design decisions.

Additional applications of the population analysis concept include the incorporation of numerical simulation techniques such as Monte Carlo simulation. This methodology has been used to provide information to engineers concerning how often crews will need to be re-selected based on the total crew mass exceeding the allowed mass. Similar methods have been applied to determine how many crewmembers might be excluded from assignments based on seating configurations that limit the critical design dimension of seated height.

In addition, the methodology of whole-body posture-based analysis utilizes the concepts of population analysis. This technique involves using fixed joint angles or body segment locations and running a simulation with each member of the standard database to calculate the range of hardware needed to accommodate the population.

Placing human factors information into context, either through defining human subjects against the population or utilizing databases to quantify accommodation, is an important step in the design process. Population analysis represents a valuable tool that enhances the role of human factors in hardware design.

REFERENCES

Deleted: critical

Human-Systems Integration Requirements (HSIR)
(2007), CxP 70024. NASA, Houston, TX.

Gordon et al (1988). 1988 Anthropometric Survey
of U.S. Army Personnel: Methods and Summary
Statistics. Tech. Report 90/044. U.S. Army
Natick Research, Development, and
Engineering Center, Natick, MA.