

NASA/CR-2008-214903



Morphing Wing Weight Predictors and Their Application in a Template-Based Morphing Aircraft Sizing Environment II Part II: Morphing Aircraft Sizing Via Multi- Level Optimization

*Michael D. Skillen and William A. Crossley
School of Aeronautics and Astronautics
Purdue University, West Lafayette, Indiana*

February 2008

The NASA STI Program Office . . . in Profile

Since its founding, NASA has been dedicated to the advancement of aeronautics and space science. The NASA Scientific and Technical Information (STI) Program Office plays a key part in helping NASA maintain this important role.

The NASA STI Program Office is operated by Langley Research Center, the lead center for NASA's scientific and technical information. The NASA STI Program Office provides access to the NASA STI Database, the largest collection of aeronautical and space science STI in the world. The Program Office is also NASA's institutional mechanism for disseminating the results of its research and development activities. These results are published by NASA in the NASA STI Report Series, which includes the following report types:

- **TECHNICAL PUBLICATION.** Reports of completed research or a major significant phase of research that present the results of NASA programs and include extensive data or theoretical analysis. Includes compilations of significant scientific and technical data and information deemed to be of continuing reference value. NASA counterpart of peer-reviewed formal professional papers, but having less stringent limitations on manuscript length and extent of graphic presentations.
- **TECHNICAL MEMORANDUM.** Scientific and technical findings that are preliminary or of specialized interest, e.g., quick release reports, working papers, and bibliographies that contain minimal annotation. Does not contain extensive analysis.
- **CONTRACTOR REPORT.** Scientific and technical findings by NASA-sponsored contractors and grantees.

- **CONFERENCE PUBLICATION.** Collected papers from scientific and technical conferences, symposia, seminars, or other meetings sponsored or co-sponsored by NASA.
- **SPECIAL PUBLICATION.** Scientific, technical, or historical information from NASA programs, projects, and missions, often concerned with subjects having substantial public interest.
- **TECHNICAL TRANSLATION.** English-language translations of foreign scientific and technical material pertinent to NASA's mission.

Specialized services that complement the STI Program Office's diverse offerings include creating custom thesauri, building customized databases, organizing and publishing research results ... even providing videos.

For more information about the NASA STI Program Office, see the following:

- Access the NASA STI Program Home Page at <http://www.sti.nasa.gov>
- E-mail your question via the Internet to help@sti.nasa.gov
- Fax your question to the NASA STI Help Desk at (301) 621-0134
- Phone the NASA STI Help Desk at (301) 621-0390
- Write to:
NASA STI Help Desk
NASA Center for AeroSpace Information
7115 Standard Drive
Hanover, MD 21076-1320

NASA/CR-2008-214903



Morphing Wing Weight Predictors and Their Application in a Template-Based Morphing Aircraft Sizing Environment II Part II: Morphing Aircraft Sizing Via Multi- Level Optimization

*Michael D. Skillen and William A. Crossley
School of Aeronautics and Astronautics
Purdue University, West Lafayette, Indiana*

National Aeronautics and
Space Administration

Langley Research Center
Hampton, Virginia 23681-2199

Prepared for Langley Research Center
under Grant NNL06AA04G

February 2008

Trade names and trademarks are used in this report for identification only. Their usage does not constitute an official endorsement, either expressed or implied, by the National Aeronautics and Space Administration.

Available from:

NASA Center for AeroSpace Information (CASI)
7115 Standard Drive
Hanover, MD 21076-1320
(301) 621-0390

National Technical Information Service (NTIS)
5285 Port Royal Road
Springfield, VA 22161-2171
(703) 605-6000

Table of Contents

Table of Contents.....	1
Nomenclature	3
I. Introduction and Project Objectives.....	3
II. Conceptual-Level Morphing Aircraft Sizing	4
A. Overview of Morphing Aircraft Sizing	4
B. Survey of Previous Morphing Aircraft Sizing Strategies	4
C. Morphing Aircraft Sizing via Problem Decomposition.....	6
1. The Morphing Wing Template Defined	6
2. Optimization Architecture	7
D. Case study – Variable Sweep / Variable Root Chord Concept.....	11
3. Morphing aircraft model.....	11
4. Mission Definition / Mission Leg Constraints.....	12
5. Top-Level Design Variable Bounds	12
6. CASE STUDY: Typical Results.....	12
7. CASE STUDY: Response Surface of Aircraft Weights Using Morphing Variables as Parameters.....	14
8. CASE STUDY: Incorporating Morphing Parameters into the Top-Level Design Variable Set.....	15
E. Conclusions	16
References	17

Nomenclature

AR	=	Wing aspect ratio
BROC	=	Best Rate of Climb
OML	=	Outer Mold Line
P_s	=	Specific Excess Power
S	=	Wing planform area
T/W	=	Aircraft thrust to weight ratio
TOGW	=	Takeoff Gross Weight
W/S	=	Wing loading
k	=	Number of subsegments defining a design mission leg
m	=	Number of mission legs in the aircraft design mission
n	=	Number of functions used to define the morphing wing template
t/c	=	Wing thickness to chord ratio
$\{X\}$	=	Set of top-level design variables
$\{X\}_{\text{morphed}}$	=	Output set of wing parameters from morphing wing template
$\{X\}_{\text{morph,ub}}$	=	Threshold values of the morphing parameters
$\{X\}_{\text{ref.}}$	=	Subset of $\{X\}$ describing the wing geometry in the reference configuration
$\{X\}_{\text{template}}$	=	Input set of wing parameters into morphing wing template
$\{\Omega\}$	=	Top-level design variable set for the morphing aircraft sizing model
Δb	=	Change in wing span
Δc	=	Change in wing chord
$\Delta \Lambda$	=	Change in quarter-chord wing sweep
β	=	Wing fold angle for the folding wing concept
λ	=	Wing taper ratio
Λ	=	Wing quarter-chord sweep angle

I. Introduction and Project Objectives

As a precursor to the contents of this report, this author would like to establish clear meaning to the word “morphing” as it will be applied here. Namely, a “morphing wing” is an aircraft wing able to drastically change planform shape during flight – perhaps a 200% change in aspect ratio, 50% change in wing area, and a 20 degree change in wing sweep.¹ Furthermore, a “morphing aircraft” refers to a conventional fixed-geometry aircraft structure with the fixed wing replaced with a morphing one. Other types of “morphing”, such as variable geometry airfoils, are not considered here.

The documentation presented here is an extension of the work presented in a NASA technical report submitted in December of 2006.² Previously, morphing-wing weight predictors were developed using simple beam-model representations of various morphing concepts. Wing weight data was generated by structurally sizing several beam models with different outer mold lines (OML) and extents of actuation; a face-centered central composite Design of Experiments (DOE) was used to prescribe these geometric models. Because no formal/industrial software exists to structurally size this type of wing platform, several structural optimization strategies were described that aimed to incorporate conventional toolsets while also including the facets of a reconfigurable structure. Using these techniques, the optimal structural design[‡] of a given wing was shown to be a function of the structural optimization strategy. The work to be presented will revisit these structural optimization techniques to demonstrate and further substantiate their performance using intermediate complexity finite element models.

Two conceptual morphing-aircraft sizing models were also previously presented and compared. The objective of these routines was to predict the major system-level aircraft parameters (i.e. thrust-to-weight ratio, wing area, wing sweep, thickness-to-chord ratio, wing aspect ratio, and wing taper) and wing shapes (morphed wing state / wing configuration) for each leg of the design mission that enabled the lowest aircraft takeoff gross weight. Both treated the morphed states of the wing as top-level design variables for each segment of the design mission. As this creates

[‡] Note that “optimal structural design” refers to an “optimal” or near optimal structural mass distribution only; the structural layout of the wing in any given configuration is assumed to be known *a priori* and remain fixed during the structural sizing task. Optimization of the structural layout / substructure topology or the morphing mechanism design is not considered in this work.

a relatively large design variable set compared to a fixed-geometry aircraft, a new technique was developed that removes the wing-state variables from the top-level design variable set. This new sizing model will be described in detail and demonstrated through various case studies using a NextGen-like morphing aircraft concept.

II. Conceptual-Level Morphing Aircraft Sizing

A. Overview of Morphing Aircraft Sizing

The objective of conceptual-level aircraft sizing is to quantify those parameters that most influence some metric of the aircraft's system-level performance; typically takeoff gross weight or cost. For fixed-geometry aircraft, this design variable set typically comprises six top-level system parameters, Ω : Wing loading (W/S), thrust-to-weight ratio (T/W), wing sweep (Λ), wing taper ratio (λ), wing thickness-to-chord ratio (t/c), and wing aspect ratio (AR). Using this set as input parameters, an aircraft sizing algorithm will predict the weight and performance of the aircraft based on governing equations of flight, simple analysis models, and/or empirically-based heuristics. The idea, then, is to find the set of values for Ω that optimizes the selected performance metric while simultaneously satisfying design mission requirements / constraints. This can be facilitated with trade studies, carpet plots, or formal numerical optimization techniques.^{3,4,5}

For morphing-type aircraft, the sizing algorithm and top-level design variable set becomes significantly more complex. Because the wing shape is now variant during flight, performance, flight characteristics, and operational capabilities of the aircraft at any point in the design mission are now a function of the wing state. Furthermore, top-level design variables will likely need to be added to account for the wing's shape variation. Clearly, treatment of these characteristics forms the crux of any morphing aircraft sizing model.

B. Survey of Previous Morphing Aircraft Sizing Strategies

In earliest reported efforts to develop a morphing-aircraft sizing process, Crossley and Roth introduced a method coined "morphing as an independent variable".⁶ In this case, a traditional iterative sizing code for fixed-wing aircraft was modified to incorporate morphing wing capabilities. These authors note that in order to fully describe the basic geometry of the aircraft throughout the design mission, the basic top-level parameter set, Ω , should be expanded to define the vehicle state (external shape) for each segment of the design mission. Their approach treated the geometric subset of Ω , $\{S, \Lambda, \lambda, t/c, AR\}$, as independent variables for each mission leg. As this substantially increased the complexity of implementing traditional trade studies / carpet plot investigations to determine an "optimal" aircraft configuration, a genetic algorithm (GA) approach was employed to facilitate the search; the GA method was selected because of localized "non-closure cases" (divergent sizing attempts) leading to a non-smooth design space. Overall, this method addressed the major facets of the problem – incorporating shape changing capabilities into the sizing process, developing a rudimentary weight prediction strategy for the morphing wing, and enabling a method to search for an "optimal" aircraft configuration – but was computationally expensive.

Further work by Frommer and Crossley aimed to develop the previous strategy into a more viable form.^{7,8} The previous issue of non-closure sizing cases was found to be a product of the problem formulation. More specifically, the aircraft vehicle was found to be morphing outside its flight envelope for various combinations of design variable values. This issue was resolved by incorporating specific excess power constraints for various mission legs and introducing "fictitious flight velocities", indicative of best available performance, when the aircraft violated its flight envelope. Such treatment enabled the continuous prediction of takeoff gross weight (the performance metric in this case) resulting in a smooth design space. For this reason, the genetic algorithm search was replaced with a more mathematically robust, gradient-based optimization algorithm; in this case, Matlab's *fmincon*⁹, an SQP-based algorithm, was incorporated. A schematic of this sizing model is shown in Figure 1.

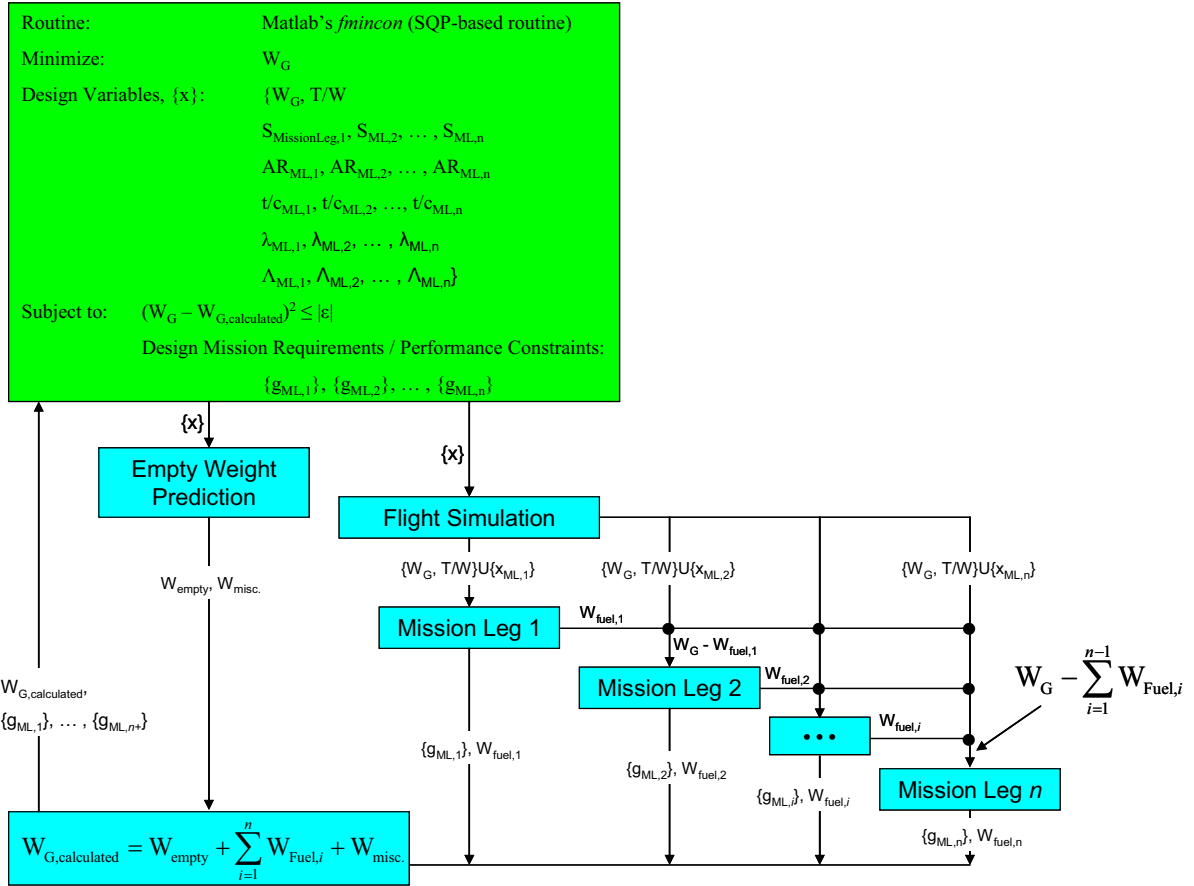

Figure 1. Basic Aircraft Sizing Architecture for the “Morphing as an Independent Variable” Approach

While both of these methods introduce a means to size aircraft with morphing wing capabilities, two facets of their implementation require critical assessment. First, incorporating independent design variables to describe the wing geometry during each mission leg results in a generic morphing wing able to vary its shape in an ad hoc manner. Such formulation generally precludes the idea of a “morphing mechanism” driving the shape changing capabilities of the wing. Although some mechanisms can be modeled by selectively choosing which variables are allowed to “morph” during each mission leg, general treatment of more complex mechanisms is difficult to implement, if not impossible. For example, a variable sweep wing could be modeled with this approach by specifying Λ as an independent variable for each mission leg and adjusting the other variables as a function of Λ over the course of the mission. However, restricting a wing model to behave as Lockheed’s folding wing design – a wing with essentially two primary wing configurations – proves inadmissible. Furthermore, the number of design variables necessary to describe the aircraft’s geometry will comprise a fairly large set, especially as the number of design mission legs increases.

A second drawback of these efforts is the method of weight prediction for the morphing wing. In both efforts, traditional fixed-geometry wing predictors were used as a basis for weight prediction. The idea, then, was to add additional weight based on the extent of shape changing capabilities of the wing; this to account for the underlying, yet undefined, morphing mechanism. Although general heuristics based on wing flaps were used to quantify this mechanism weight, for lack of a better model, this approach is justifiable as long as results are approached with some level of skepticism.

In a more recent approach, this author incorporated the idea of a morphing wing “template” to model the operational capabilities of the wing. In this case, the wing “template” develops a reference wing configuration (shape) from the geometric variables from the top-level design variable set, Ω . The template also parametrically defines the shape changing capabilities of the wing as a function of “morphing parameters”. Specification of the reference wing geometry and current state of the morphing parameters enables the template to output a set of parameters describing the morphed shape of the wing (e.g. $AR_{morphed}$, $\Lambda_{morphed}$, etc.). The top-level design variable

set was then expanded to include a set of morphing parameters for each leg of the design mission. The major drawback in this case is that the wing is required to maintain a constant shape during an entire mission leg. However, during a long cruise at constant altitude and speed for example, the wing shape would likely change to maintain aerodynamic efficiency. The sizing algorithm to be described will incorporate this flight capability and reduce the top-level design variable set to the original fixed-geometry set, Ω .

C. Morphing Aircraft Sizing via Problem Decomposition

The morphing aircraft sizing approach to be developed here will still incorporate the idea of a morphing wing template, but will aim to remove the wing state variables from the top-level design variable set. The basic premise underlying this sizing model is that the external geometry for a “reference” configuration of the morphing aircraft, as well as a small set of parameters describing the maximum shape changing capabilities, will be defined using a top-level design variable set. The “shape history” of the wing will then be determined for each segment of the design mission such that some specified performance metric is optimized (e.g. minimize fuel expenditure over mission leg i). This precludes, but still allows, the idea of fixing the wing geometry to a specified configuration for the duration of a mission segment – like was done in past aircraft sizing models – and enables the aircraft sizing venue to more readily simulate the operational capabilities of the morphing aircraft.

1. The Morphing Wing Template Defined

The morphing wing “template” is essentially an input/output mechanism to parametrically model the operational shape-changing capabilities of the wing. The geometric subset, $\{X\}_{\text{template}}$, of the top-level design variables, Ω , is used as input to define the geometry of a reference wing configuration (e.g. the unswept configuration of a conventional swing-wing concept). The template definition operates on this input using a set of functions that describe how the geometry of the wing changes from the reference configuration as a function of morphing parameters; the requested state of these parameters will also be used as input into the template function. An important note is that the morphing parameters will have a domain from zero, indicating the reference configuration value, and some upper limit that bounds the extent of shape changing capabilities available. The output information is a set of geometric parameters fully describing the OML geometry (planform arrangement, t/c , Λ , λ , etc.) and the relevant system-level parameters (S_{wing} , AR_{wing} , $\Lambda_{\text{wing, effective}}$, etc.).

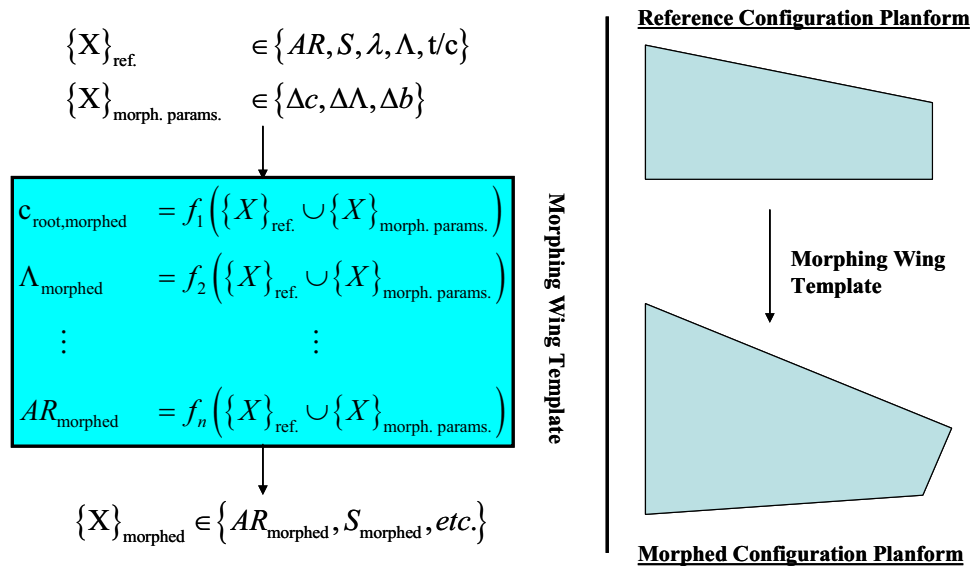

Figure 2. Generalization of a Morphing Wing “Template”

2. Optimization Architecture

As described above, this morphing aircraft sizing architecture will be decomposed into two levels of optimization: 1) the top-level optimization that searches for the best parameter values describing the major aircraft system-level metrics, and 2) the set of sub-optimization problems that, for any given mission leg, searches for the wing state history optimizing the aircraft's operational performance. The top-level design task will be described first.

Figure 3 illustrates the top-level optimization task for the morphing aircraft sizing model. The objective is to minimize the predicted takeoff gross weight of the aircraft, $W_{G,guess}$. The design variable set, $\{x\}$, establishes the necessary information to fully define the major system-level parameters of the aircraft including: Maximum sea-level thrust ($\{T/W\} \cup \{W_{G,guess}\}$), major geometric features of the wing in the reference configuration ($\{X\}_{ref}$), and the threshold values for the operational shape-changing capabilities of the wing ($\{X\}_{morph,ub}$). The idea behind the threshold values of the morphing parameters is best described by example. Given a conventional variable sweep wing, the unswept reference configuration would be described by the variables $\{X\}_{ref}$, including the leading edge sweep; the sweep angle would be represented by the morphing parameter Λ . The threshold value of Λ , $\Delta\Lambda_{ub}$, would act to bound the sweep angle variation to the specified value (e.g., $\Delta\Lambda_{ub} = 30$ [deg]: from the reference configuration sweep angle, allow the wing to increase its sweep angle by no more than 30 degrees). Thus, the threshold morphing parameter values act to restrict the morphing capabilities of the wing. In the documentation to follow, the morphing wing weight will be shown to be a function of the extent of actuation of the morphing mechanism, $\{X\}_{morph,ub}$. More specifically, the more the wing can deviate from its reference configuration shape, generally, the more it will weigh. Therefore, some system-level tradeoff should exist between the extent of actuation of the wing, and the system-level performance increase enabled by the morphing capabilities.

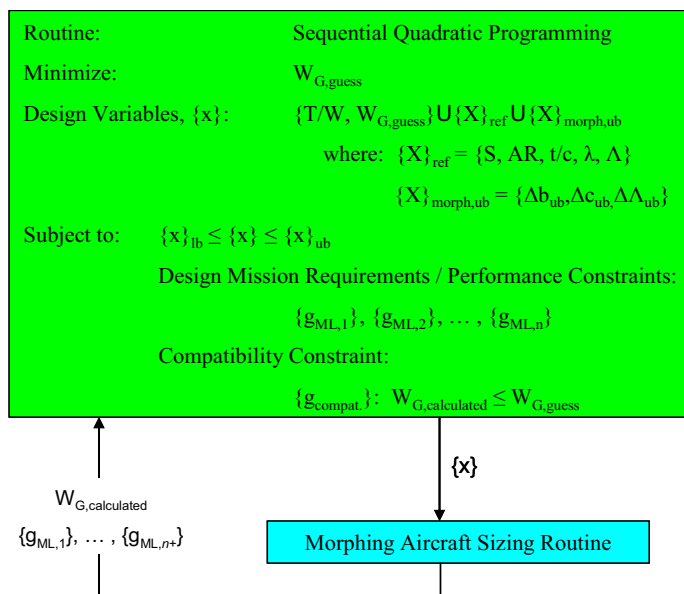

Figure 3. Top-Level Optimization Task for the Morphing Aircraft Sizing Model

The design constraints in this model constitute a maximum takeoff parameter, flight envelope constraints (excess power ≥ 0 , $C_L \leq C_{L,max}$), landing distance constraints, etc. Violation / satisfaction of these are determined within the morphing aircraft sizing routine. By virtue of the problem formulation, this sizing model requires a compatibility constraint to ensure that the guessed takeoff gross weight does not exceed the calculated takeoff gross weight as predicted by the aircraft sizing routine. The idea, here, is that a guessed TOGW is required to simulate the flight performance and predict fuel consumption during the course of the design mission. If the guessed weight of the aircraft exceeds the calculated takeoff gross weight, the guessed takeoff gross weight can be reduced without adverse variation of the constraint values. As will be demonstrated in the case studies to follow, the compatibility constraint drives itself naturally into the active set such that the error between the guessed TOGW and the calculated TOGW is negligible.

Next, the morphing aircraft sizing routine will be more rigorously defined, including the sub-optimization problems within the individual mission segment simulations. The sizing routine is first initialized by reading the design variable values and establishing the overall geometry of the aircraft based on these parameters. The reference wing configuration geometry is defined directly from the $\{X\}_{\text{ref}}$ subset of $\{X\}$. The length of the fuselage is fixed in the current sizing model and is used to establish moment arm lengths from the main wing to the horizontal and vertical stabilizers. Using the volume coefficient method as presented in Raymer¹⁰, the surface area is determined as a function of the moment arm length, volume coefficient for the appropriate empennage surface, and various geometric metrics of the main wing. Because the aspect ratio, sweep, and thickness-to-chord ratio are fixed for the stabilizer surfaces throughout the sizing routine based on readily available heuristics, the surface geometry of the conventional-configuration empennage is entirely known at this point. A noteworthy point of implementation is that the main wing geometry parameters used in the volume coefficient technique uses wing dimensions (possibly from morphed states) that act to maximize the predicted stabilizer size. For example, the horizontal tail size is maximized when the product of the main wing's mean aerodynamic chord and planform area are maximized. Therefore, the sizing routine searches the shape domain of the wing (via morphing wing template) for the maximum value of this parameter, and then uses this to calculate the predicted horizontal tail area. All necessary information to define the external geometry of the aircraft is now available and aerodynamic metrics such as drag and lift coefficients in any morphed configuration can be determined based on conceptual-level techniques.

Using the guessed TOGW and the external geometry of the aircraft, the empty weight of the aircraft can be calculated using component weight predictors (Ref. 10, pgs. [473-476]). Because these equations are developed using fielded aircraft data, the predicted weight estimate corresponds to flight-ready components. An important note is that there is no fielded component data to establish a morphing wing weight predictor, and therefore, an accurate wing weight estimate. However, strategies by this author have provided a surrogate predictor for this weight estimate as a function of the major geometric wing parameters, extents of actuation, aircraft TOGW, and ultimate load factor.^{11,12,13} The equation below is presented as a demonstration of this type of morphing wing weight predictor; a variable root chord / variable sweep morphing wing concept was used to develop this equation. The $\Delta\Lambda$ and Δc_{root} terms represent the threshold values of the morphing parameters. As this equation suggests, an increase in the morphing capabilities of the wing tends to increase the total predicted wing weight. For example, a maximum sweep angle variation of 10 degrees translates to a k-factor of ~ 1.05 , while a variation of 30 degrees imposes a k-factor of ~ 1.14 ; a significant change in wing weight. However, to what extent this added weight acts on the system-level performance depends largely on the design mission and the associated impact of the shape-changing capabilities on it.

$$W_{\text{wing}} = (0.0352 \cdot W_G) \cdot \frac{S^{0.4516} \cdot (\text{AR})^{1.3520} \cdot (1 + \lambda)^{0.7850} \cdot \left(1 + \frac{\Delta\Lambda_{\text{ub}}}{90}\right)^{0.4524} \cdot (1 + \Delta c_{\text{root,ub}})^{0.0252}}{(1 + \cos \Lambda)^{4.8970} \cdot (100 \cdot t/c)^{0.8870} \cdot \left(\frac{W/S}{10}\right)^{0.0045}} \quad (1)$$

Next, the aircraft's flight is simulated for the user-specified design mission. Using the guessed TOGW as the initial weight, each mission segment is simulated using rudimentary analysis models based on general governing equations of flight, and the corresponding fuel expenditure is tracked. Upon analysis of the entire design mission, the total fuel expenditure is calculated. The exact treatment of the mission leg analysis will be discussed shortly. With the aircraft empty weight predicted, as well as the total estimated fuel expenditure, the "calculated" aircraft TOGW is calculated by summing these values. This value and the constraint variable values calculated from the individual mission leg simulations are then sent back to the top-level design task to determine a usable-feasible search direction to update the current design variable values. This process is iterated until adequate convergence criteria are met. An overview of the morphing aircraft sizing architecture is illustrated in Figure 4 as a graphical reference to the preceding discussion.

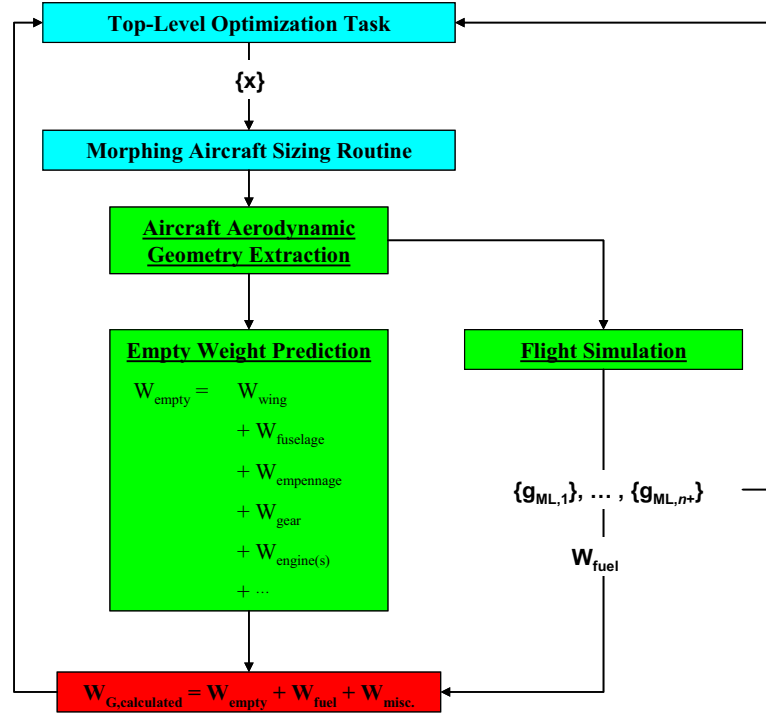

Figure 4. Overview of the Morphing Aircraft Sizing Routine Architecture

Until this point, the aircraft sizing task has followed a relatively straightforward, conventional approach. This section will develop the morphing aircraft simulation model that tends to deviate significantly from the fixed-geometry aircraft approach, but is necessary to appropriately incorporate the facets of a reconfigurable aircraft. The basic flight simulation architecture and information flow is illustrated in Figure 5. This has similarity to the “morphing as an independent variable” approach (Figure 1), but the input into the individual mission legs has changed to only require the aircraft’s reference geometry. The aircraft’s weight at the beginning of the mission leg is still incorporated in a feed-forward scheme, however, and is calculated by subtracting the fuel expenditure from all of the previous segments from the guessed TOGW. After all mission segments have been analyzed, the total fuel weight is calculated and the mission leg constraint vectors collocated into a single vector to feedback to the top-level optimization task.

The reader is now in a position to understand the sub-optimization problem inherent to a majority of the design mission segments. For any given mission leg, the weight at the beginning of the mission segment and the aircraft’s reference geometry are input into the design task. The mission segment is then discretized into a number of smaller segments (user-specified information) such that approximate flight simulation models – Breguet’s range equation or the endurance equation – can be applied. The design task will then sequentially find the wing shape for each of these discretized segments such that some performance metric of the flight simulation is optimized; the common objective is to minimize fuel expenditure. Because the morphing wing template defines the morphed shape of the wing as a function of the user-defined morphing parameters, the optimization technique need only search the domain of the morphing parameters to determine the optimal shape. Equivalently stated, the morphing parameters will act as design variables during the optimization task, and will be bound by their lower-bound values, $\{0\}$, and their upper-bound threshold values, $\{X\}_{\text{morph,ub}}$. The design constraint set is dependent on the mission segment being analyzed, but most will enforce flight envelope constraints ($C_L \leq C_{L,\text{max}}$, $P_s \geq 0$). Because the shape domain of the wing might not enclose a feasible system-level design for a given mission segment(s), it is necessary to determine the aircraft’s best achievable performance, in this situation, so that the entire design mission can be simulated, and the necessary constraint and objective information can be fed back to the top-level design task; this will avoid the runtime condition where “non-closure” design cases create a non-smooth design space. Therefore, a modified exterior penalty method approach has been employed to model the objective function. This method is used to ensure that this mission segment optimization task returns a feasible constraint value back to the top-level optimization task, if a feasible design exists; an unmodified exterior penalty method has the potential to report an infeasible

design when a feasible design might actually exist. Figure 6 illustrates the overall architecture of the mission leg optimization task as well as the dominant information flows. Note that the constraint variable vector that is returned to the top-level optimization task does not include all the constraint value information obtained from each of the subsegments; the routine selectively chooses appropriate / most relevant information from this set. For example, a constant altitude / constant speed cruise mission will only return the specific excess power constraint value for the first segment of the mission, where the aircraft will weigh the most, lift requirements (and corresponding induced drag) will be the greatest, and thrust needs will be maximized.

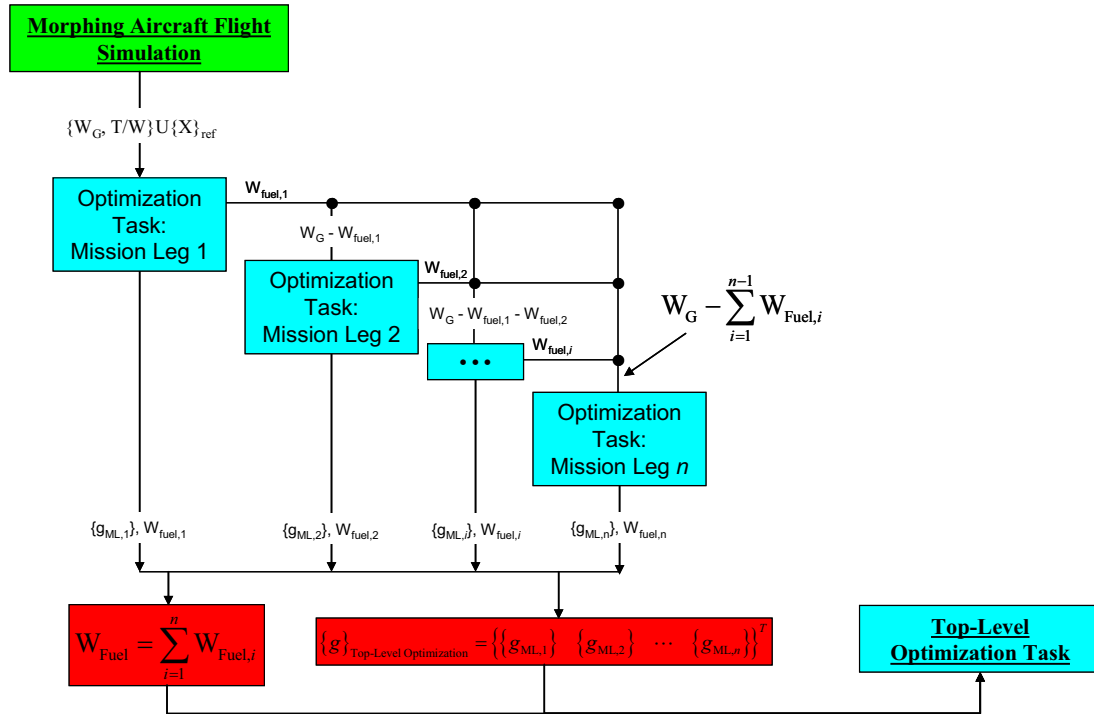

Figure 5. Overview of the Morphing Aircraft Flight Simulation Architecture

At this point, the primary architecture of this morphing aircraft sizing model has been discussed. The only topic left unresolved is the exact treatment of the individual mission leg simulation models. For sake of simplicity, these simulation modules will not be reproduced here, but the reader is referred to Reference 10 for potential techniques.

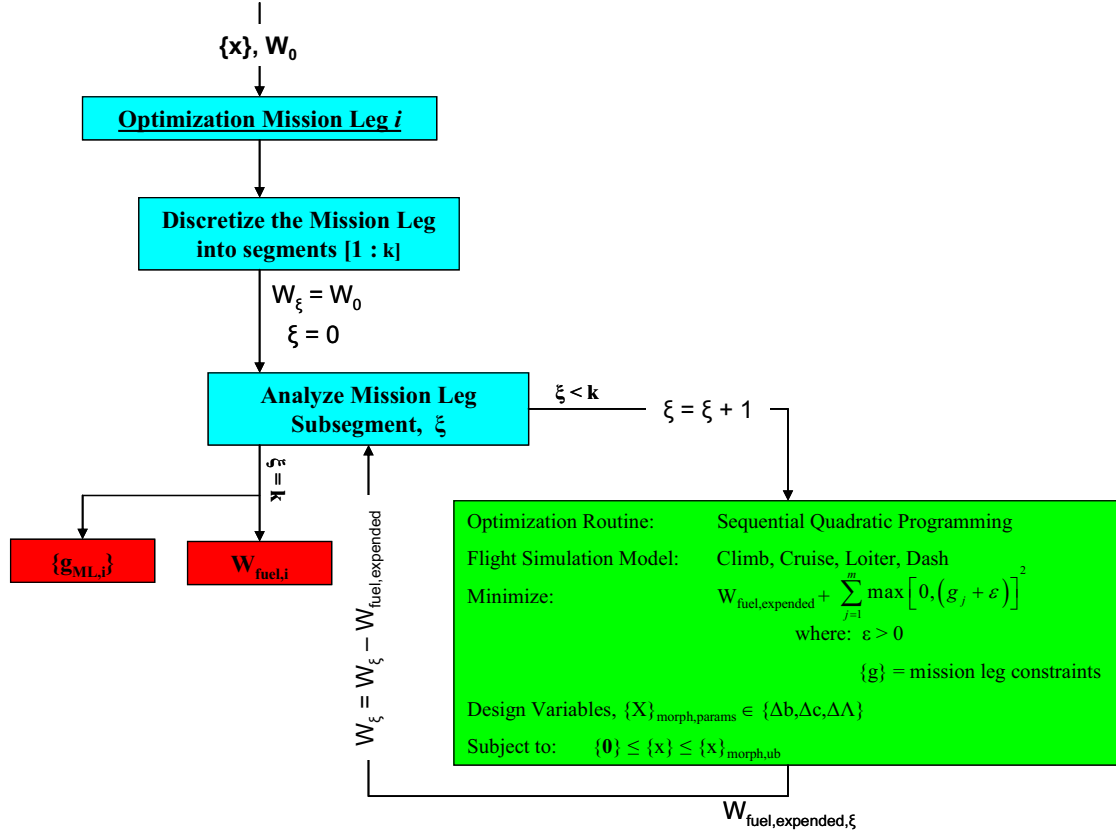

Figure 6. Schematic of the Mission Leg Optimization Architecture

D. Case study – Variable Sweep / Variable Root Chord Concept

The following case study will demonstrate the morphing aircraft sizing model described above using a NextGen-like morphing aircraft concept.

3. Morphing aircraft model

The morphing wing model will use the following parameters as top-level design variables:

$$\{X\} \equiv \{W_G, T/W\} \cup \{S, AR, \Lambda_{LE}, t/c\} \quad (2)$$

Notice that the second set of design variables defines geometric characteristics of the wing in the reference configuration; the taper ratio in this configuration has been fixed to a value of 0.3. The morphing parameters are described by two variables, including:

$$\{X\}_{morph, params.} \equiv \{\Delta c, \Delta \Lambda_{LE}\} \quad (3)$$

The “ Δc ” term indicates the percentage increase of the root chord length with respect to the reference configuration value (e.g. $\Delta c = 0.50$ indicates that the wing can increase its root chord length by 50 percent from the reference configuration root chord length). The “ $\Delta \Lambda_{LE}$ ” term is a normalized parameter (w.r.t. 90 degrees) that indicates the sweep angle variation with respect to the reference configuration value (e.g. $\Delta \Lambda_{LE} = 0.50$ indicates that the leading edge sweep of the wing has increased by 45 degrees with respect to the reference sweep angle, Λ_{LE}).

The fuselage length is fixed at 60 feet and has a maximum diameter of 5 feet. The horizontal and vertical stabilizers are sized using the volume coefficient method, as described previously. Specifically, the horizontal tail

has a volume coefficient of 0.7, a leading edge sweep of 35 degrees, a taper ratio of 0.35, and an aspect ratio of 6. The vertical tail has a volume coefficient of 0.06, a leading edge sweep of 35 degrees, a taper ratio of 0.6, and an aspect ratio of 1.5. The aircraft model incorporates two turbofan engines, each with a bypass ratio of 5.

4. Mission Definition / Mission Leg Constraints

The following table defines the design mission used to size the morphing aircraft in this demonstrational case study:

Leg	Type	Altitude	Description	Constraints
1	Startup, Taxi, Takeoff	[0] ft.	---	TOP ≤ 155
2	Climb	[0 30]x1000 ft.	BROC	Ps ≥ 0, CL ≤ CL_max
3	Cruise	[30 30]x1000 ft.	Mach 0.7, Distance = 1500 [nm]	Ps ≥ 0, CL ≤ CL_max
4	Loiter	[30 30]x1000 ft.	Endurance = 4 [hrs]	Ps ≥ 0, CL ≤ CL_max
5	Descend	[30 5]x1000 ft.	No range credit	---
6	Dash	[5 5]x1000 ft.	Mach 0.8, Distance = 250 [nm]	Ps ≥ 0, CL ≤ CL_max
7	Climb	[5 20]x1000 ft.	BROC	Ps ≥ 0, CL ≤ CL_max
8	Cruise	[20 20]x1000 ft.	Mach 0.7, Distance = 1500 [nm]	Ps ≥ 0, CL ≤ CL_max
9	Descend	[20 0]x1000 ft.	No range credit	---
10	Land, Taxi, Shutdown	[0] ft.	V_approach = 1.2*V_stall	Landing Distance ≤ 5500 [ft]

Table 1 Morphing Aircraft Design Mission

5. Top-Level Design Variable Bounds

Design Variable	Bounds		Units
	Lower	Upper	
TOGW	20000	40000	[lb]
T/W	0.3	0.8	[]
S	100	350	[ft^2]
AR	5	12	[]
Δ (LE)	5	30	[deg]
t/c	6	18	[%]

Table 2 Top-Level Design Variable Bounds

6. CASE STUDY: Typical Results

This first case study will demonstrate detailed results for a typical morphing aircraft sizing run. Here, the threshold morphing parameter values will be fixed such that the top-level design variable set comprises the aircraft's takeoff gross weight, maximum required sea-level thrust, and the variables describing the wing geometry in the reference configuration. Because the morphing parameter threshold values are fixed, the wing will have the capability to vary its geometry to these extremes, but is not required to operate at the threshold values during the flight simulation. This is an important consideration because the added mechanism weight required to enable actuation to the threshold values might be sizing the aircraft heavy to carry the extra weight. In a later case study, the threshold values will be added as design variables into the top-level design set to achieve an "optimally" sized aircraft with "optimal" morphing capabilities.

In this case, the morphing wing will be capable of producing a 95 percent increase in root chord length, and will be able to increase its sweep aft by 30 degrees from the reference wing sweep angle. Table 3 shows the initial design variable values as well as the reported optimal values. Figure 7 illustrates a planform view of the aircraft at the beginning of each leg of the design mission. Notice that takeoff and landing configurations morph the wing to a

large planform area, and the wing is configured to a large sweep angle during the dash leg; of course, these are expected results. Figure 8 illustrates an example of the wing shape history during the first cruise leg of the design mission. Here, the morphing parameter values are plotted against the subsegment index of the cruise leg. Notice that the wing sweep parameter is zero over the course of the mission segment indicating the wing sweep angle is at the reference configuration value (i.e. $\Lambda_{LE} = 10.3$ degrees). The root chord length morphing parameter begins the mission leg at a length ~ 60 percent greater than the reference configuration value, but reduces almost linearly to a value of ~ 50 percent. This suggests that as fuel is being burned during cruise, the wing area is being reduced to maintain an efficient aerodynamic condition. If the reader considers that the wing span length is maintained, the change in wing planform area effectively increases the wing aspect ratio, which reduces induced drag.

Design Variables	{x0}	{x}*
WGuess	30000	28151.56
ThrustToWeight	0.55	0.51
S	325	155.74
AR	7	12.00
SweepLE	0.325	0.18
ThicknessToChord	0.12	0.15

Table 3 Initial and Optimal Design Variable Values for the Typical Results Case Study

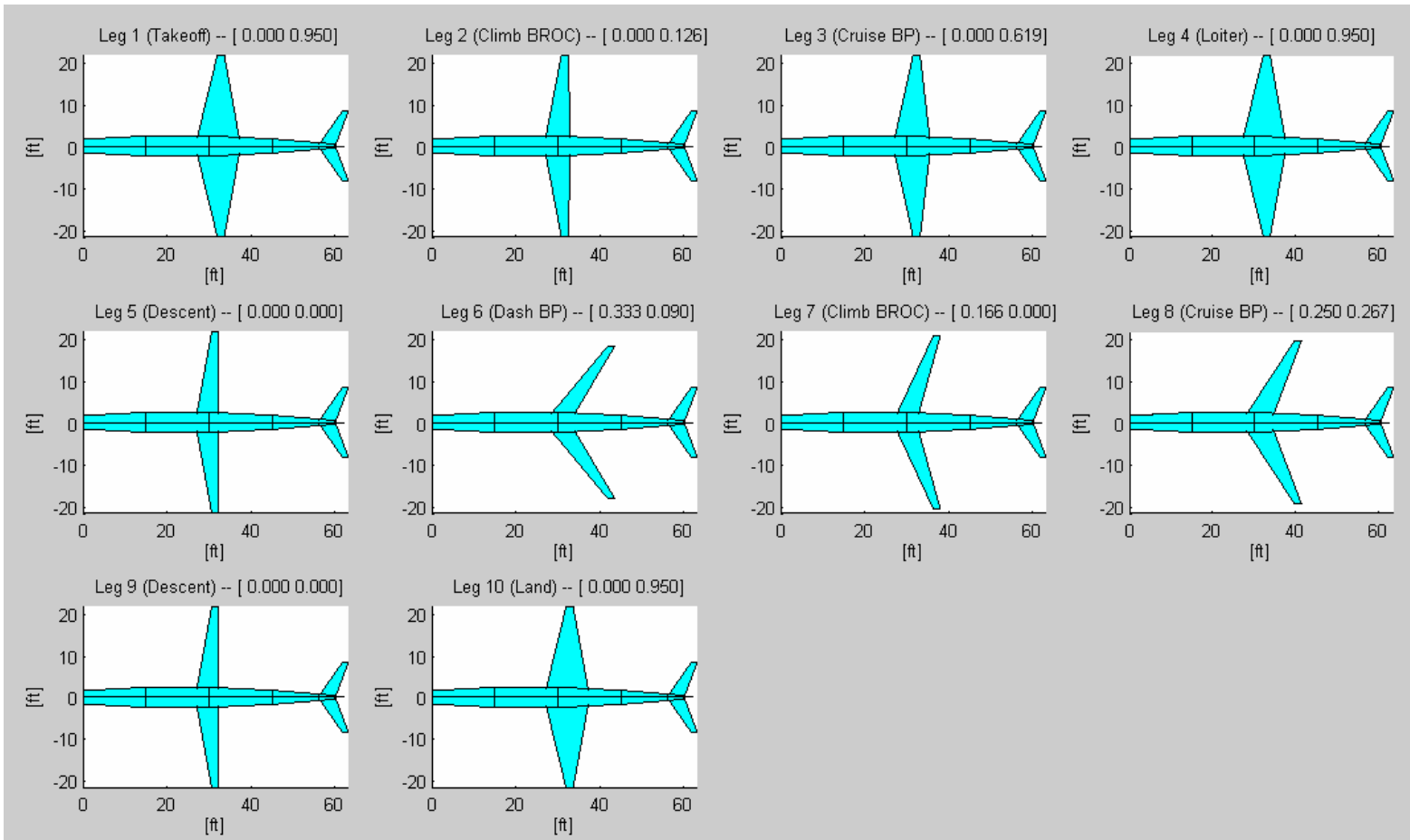

Figure 7 Aircraft Planform View of the Wing State at the Beginning of Each Design Mission Leg



Figure 8 Wing Shape History During the First Cruise Leg

7. *CASE STUDY: Response Surface of Aircraft Weights Using Morphing Variables as Parameters*

This case study is setup similarly to the previous study where the threshold values of the morphing parameters are held fixed during the sizing process. This approach will be revisited, except that several sizing runs will be performed at different threshold values. This will enable some level of visualization of the design space, where the “optimal” TOGW and maximum installed thrust values can be plotted against the morphing parameter threshold values. In the next case study, the threshold values will be added to the top-level design variable set; the trade study performed in this section will aid in predicting the “optimal” threshold values in the next study and will provide validation for those results.

The following tables indicate the TOGW and maximum required installed thrust values for various combinations of threshold values.

		$\Delta\Lambda$ [deg]		
		1	15	30
ΔC_{root} [%]	TOGW [lb] @ (X)*			
	5	26600.36	25876.90	25671.51
	35	26744.29	26455.11	26330.91
	65	27572.36	27307.43	27198.58
	95	28560.86	28306.82	28151.56
ΔC_{root} [%]	Max. Thrust [lb] @ (X)*			
	5	12559.04	12223.49	12124.97
	35	12863.93	12892.51	12702.04
	65	13548.04	13596.75	13739.47
	95	14393.51	14302.58	14264.14

Table 4 Performance Metrics from Aircraft Sizing Results using the Morphing Parameter Threshold Values as Fixed Parameters

Notice that the “ Δc ” parameter domain has been discretized to four points (5, 35, 65, and 95 percent variation), while the “ $\Delta\Lambda$ ” parameter has been discretized to three (1, 15, and 30 degrees of maximum sweep variation). For every point within this table, an aircraft sizing run was performed; a typical run required ~2 hours of continuous runtime. Figure 9 illustrates this information graphically using bi-linear interpolation between data points. Notice

that the lowest reported TOGW and maximum installed thrust occurs with morphing parameter threshold values of 30 degrees maximum sweep angle variation and 5% variation of the root chord length. This suggests that the aerodynamic trends enabled by root chord variation lead to performance degradation in the system-level parameters considered here (i.e. TOGW and installed thrust requirements are increased for the designed aircraft) but introducing leading edge sweep variation leads to desirable system-level performance trends for this particular design mission. This does not suggest that root chord variation is an overall poor design characteristic, but for the mission requirements demanded in this case, it does.

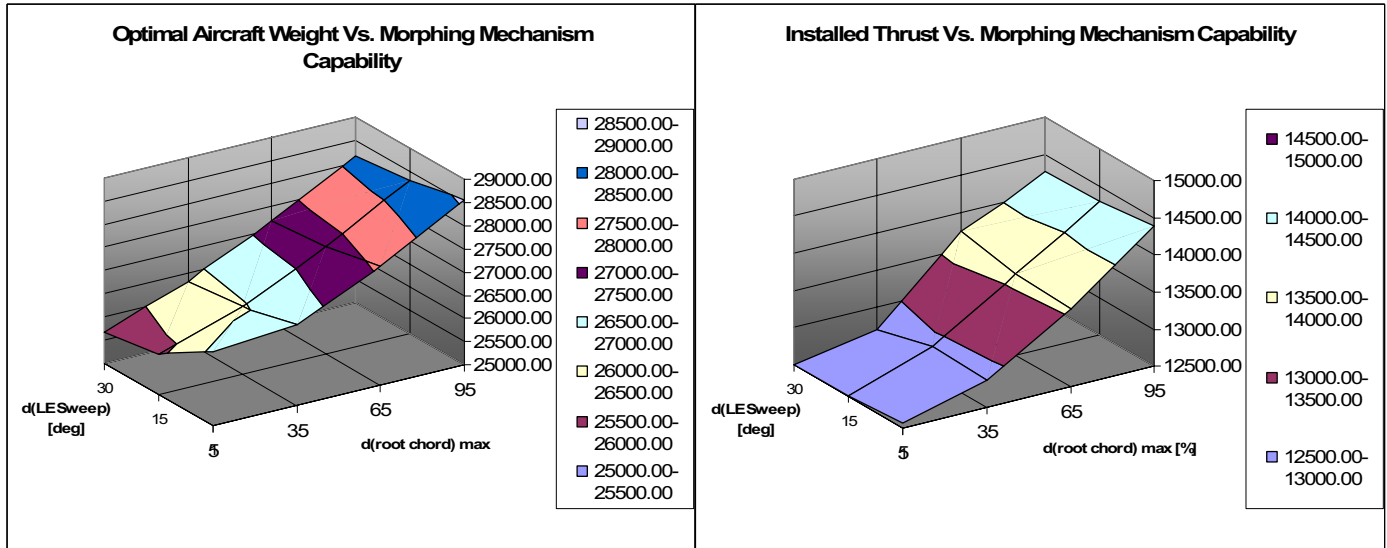

Figure 9 Graphical Illustration of Table 3: Performance Metrics from Aircraft Sizing Results

8. CASE STUDY: Incorporating Morphing Parameters into the Top-Level Design Variable Set

The idea now is to introduce the morphing parameter threshold values as top-level design variables. These design variables will be bound using the extreme values of the previous case study; specifically, Δc : [0 95]% and “ $\Delta\Lambda$ ”: [0 30] degrees. The aircraft sizing task was started from various initial conditions to help validate the global optimality of the solutions. Figure 10 revisits the plot from Figure 9 and illustrates various initial morphing parameter threshold values (shown as circles) as well as the “optimal” values (shown as an “x”) as determined by the aircraft sizing routine. Notice that the solution has converged to the values enabling the lowest predicted TOGW (recall that the contour plot uses bilinear interpolation between the discrete data points). This is encouraging because it suggests the design space is smooth and the problem setup is robust / well conditioned. For reference, the actual optimal design variable values are shown in Table 4.

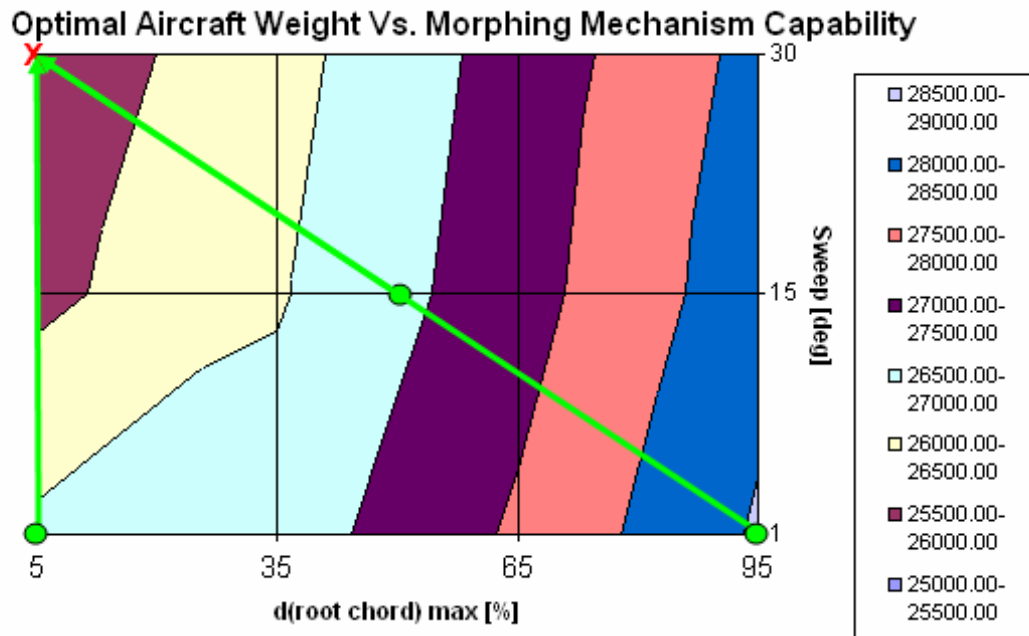

Figure 10 Optimal Morphing Parameter Threshold Values Starting from Several Initial Conditions

Design Variable	x*			Units
	Trial 1	Trial 2	Trial 3	
WGuess	25691.51	25691.84	25659.09	[lb]
ThrustToWeight	0.47	0.47	0.47	[]
S	197.86	203.92	195.96	[ft^2]
AR	11.91	11.99	12.00	[]
SweepLE	0.18	0.23	0.21	[rad]
ThicknessToChord	0.14	0.14	0.14	[]
MPDswpMaxDeg	30.00	30.00	29.93	[deg]
MPDcrootMaxPrct	5.36	5.10	5.00	[%]

Table 5 Optimal Design Variable Values for Various Initial Conditions

E. Conclusions

The morphing aircraft sizing model presented here enables rapid conceptual-level evaluation of novel morphing aircraft concepts. Based on the previous case studies, the sizing routine appears to be well conditioned and allows continuous morphing over the design mission legs. This is a major feature that had been unrealized in previous morphing aircraft sizing models.

The typical runtime performance of the sizing code implemented for this documentation is reasonable. A complete design run with morphing parameter threshold values in the design variable set generally requires on the order of 2 hours; these values are based on a dedicated laptop computer, Pentium IV processor (2.8 GHz), running Windows XP and Matlab 7.1 (R14).

References

- ¹ Wall, R., "Darpa Eyes Materials for 'Morphing' Aircraft," *Aviation Week and Space Technology*, April 8, 2002.
- ² Skillen, M., and Crossley, W., "Modeling and Optimization for Morphing Wing Concept Generation," NASA Technical Reports Server (NTRS), [<http://ntrs.nasa.gov/search.jsp>], accessed Aug. 2007.
- ³ Sobieski, I., and Kroo, I., "Aircraft Design using Collaborative Optimization," AIAA-1996-715, Aerospace Sciences Meeting and Exhibit, 34th, Reno, NV, Jan. 15-18, 1996.
- ⁴ Kroo, I., Altus, S., Braun, R., Gage, P., and Sobieski, I., "Multidisciplinary Optimization Methods for Aircraft Preliminary Design," AIAA-1994-4325, IN:AIAA/USAF/NASA/ISSMO Symposium on Multidisciplinary Analysis and Optimization, 5th, Panama City Beach, FL, Sept 7-9, 1994, Technical Papers. Pt. 1 (A94-36228 12-66), Washington, DC, AIAA, 1994, p. 697-707.
- ⁵ Jaroslaw Sobieszczanski-Sobieski; Jeremy S. Agte; Robert R. Sandusky, "Bilevel Integrated System Synthesis," *AIAA Journal* 2000, 0001-1452 vol.38 no.1 (164-172).
- ⁶ Roth, B., and Crossley, W., "Application of Optimization Techniques in the Conceptual Design of Morphing Aircraft," AIAA-2003-6733, AIAA's 3rd Annual Aviation Technology, Integration, and Operations (ATIO) Forum, Denver, Colorado, Nov. 17-19, 2003.
- ⁷ Frommer, J., and Crossley, W., "Enabling Continuous Optimization for Sizing Morphing Aircraft Concepts," AIAA-2005-816, 43rd AIAA Aerospace Sciences Meeting and Exhibit, Reno, Nevada, Jan. 10-13, 2005.
- ⁸ Frommer, J., and Crossley, W., "Evaluating Morphing Aircraft in a Fleet Context Using Non-Deterministic Metrics," AIAA-2005-7460, AIAA 5th ATIO and 16th Lighter-Than-Air Sys Tech. and Balloon Systems Conferences, Arlington, Virginia, Sep. 26-28, 2005.
- ⁹ MATLAB, Software Package, Ver. 7.1.0.246, Release 14, The MathWorks, Inc., Natick, MA, 2005.
- ¹⁰ Raymer, D., *Aircraft Design: A Conceptual Approach*, AIAA Education Series, American Institute of Aeronautics and Astronautics, Reston VA, 3rd Edition, 1999.
- ¹¹ Skillen, M., and Crossley, W., "Developing Response Surface Based Wing Weight Equations for Conceptual Morphing Aircraft Sizing," AIAA-2005-1960, 46th AIAA/ASME/ASCE/AHS/ASC Structures, Structural Dynamics, and Materials Conference and 13th AIAA/ASME/AHS Adaptive Structures Conference, Austin, Texas, Apr. 18-21, 2005.
- ¹² Skillen, M., "Developing Response Surface based Wing Weight Equations for Conceptual Morphing Aircraft Sizing," MS Thesis, School of Aeronautics and Astronautics, Purdue University, West Lafayette, IN, Dec. 2005.
- ¹³ Skillen, M., and Crossley, W., "Developing Morphing Wing Weight Predictors with Emphasis on the Actuating Mechanism" AIAA-2006-2042, 47th AIAA/ASME/ASCE/AHS/ASC Structures, Structural Dynamics, and Materials Conference and 14th AIAA/ASME/AHS Adaptive Structures Conference, Newport, Rhode Island, May 1-4, 2006.

REPORT DOCUMENTATION PAGE

*Form Approved
OMB No. 0704-0188*

The public reporting burden for this collection of information is estimated to average 1 hour per response, including the time for reviewing instructions, searching existing data sources, gathering and maintaining the data needed, and completing and reviewing the collection of information. Send comments regarding this burden estimate or any other aspect of this collection of information, including suggestions for reducing this burden, to Department of Defense, Washington Headquarters Services, Directorate for Information Operations and Reports (0704-0188), 1215 Jefferson Davis Highway, Suite 1204, Arlington, VA 22202-4302. Respondents should be aware that notwithstanding any other provision of law, no person shall be subject to any penalty for failing to comply with a collection of information if it does not display a currently valid OMB control number.
PLEASE DO NOT RETURN YOUR FORM TO THE ABOVE ADDRESS.

1. REPORT DATE (DD-MM-YYYY) 01-02-2008		2. REPORT TYPE Contractor Report		3. DATES COVERED (From - To) 11-04-2006 to 10-31-2007	
4. TITLE AND SUBTITLE Morphing Wing Weight Predictors and Their Application in a Template-Based Morphing Aircraft Sizing Environment II - Part II: Morphing Aircraft Sizing Via Multi-Level Optimization				5a. CONTRACT NUMBER	
				5b. GRANT NUMBER NNL06AA04G	
				5c. PROGRAM ELEMENT NUMBER	
6. AUTHOR(S) Skillen, Michael D.; and Crossley, William A.				5d. PROJECT NUMBER	
				5e. TASK NUMBER	
				5f. WORK UNIT NUMBER 659877.02.07.05.9S51.02	
7. PERFORMING ORGANIZATION NAME(S) AND ADDRESS(ES) NASA Langley Research Center Hampton, VA 23681-2199 Purdue University School of Aeronautics and Astronautics West Lafayette, IN 47907-2023				8. PERFORMING ORGANIZATION REPORT NUMBER	
9. SPONSORING/MONITORING AGENCY NAME(S) AND ADDRESS(ES) National Aeronautics and Space Administration Washington, DC 20546-0001				10. SPONSOR/MONITOR'S ACRONYM(S) NASA	
				11. SPONSOR/MONITOR'S REPORT NUMBER(S) NASA/CR-2008-214903	
12. DISTRIBUTION/AVAILABILITY STATEMENT Unclassified - Unlimited Subject Category 05 Availability: NASA CASI (301) 621-0390					
13. SUPPLEMENTARY NOTES Langley Technical Monitor: Jamshid A. Samareh An electronic version can be found at http://ntrs.nasa.gov					
14. ABSTRACT This report presents an approach for sizing of a morphing aircraft based upon a multi-level design optimization approach. For this effort, a morphing wing is one whose planform can make significant shape changes in flight - increasing wing area by 50% or more from the lowest possible area, changing sweep 30° or more, and/or increasing aspect ratio by as much as 200% from the lowest possible value. The top-level optimization problem seeks to minimize the gross weight of the aircraft by determining a set of "baseline" variables - these are common aircraft sizing variables, along with a set of "morphing limit" variables - these describe the maximum shape change for a particular morphing strategy. The sub-level optimization problems represent each segment in the morphing aircraft's design mission; here, each sub-level optimizer minimizes fuel consumed during each mission segment by changing the wing planform within the bounds set by the baseline and morphing limit variables from the top-level problem.					
15. SUBJECT TERMS Morphing; Aircraft design; Wing design; Structural optimization; Simultaneous analysis optimization; Sequential optimization; Aggregate optimization					
16. SECURITY CLASSIFICATION OF:			17. LIMITATION OF ABSTRACT	18. NUMBER OF PAGES	19a. NAME OF RESPONSIBLE PERSON
a. REPORT	b. ABSTRACT	c. THIS PAGE			STI Help Desk (email: help@sti.nasa.gov)
U	U	U	UU	22	19b. TELEPHONE NUMBER (Include area code) (301) 621-0390