



US007273095B2

ARC-15173-1

(12) **United States Patent**
Li et al.

(10) **Patent No.:** **US 7,273,095 B2**
(45) **Date of Patent:** **Sep. 25, 2007**

(54) **NANOENGINEERED THERMAL MATERIALS BASED ON CARBON NANOTUBE ARRAY COMPOSITES**

6,231,744 B1 5/2001 Ying et al. Source of Acquisition
6,340,822 B1 1/2002 Brown et al. NASA Washington, D. C.

(75) Inventors: **Jun Li**, Sunnyvale, CA (US); **Meyya Meyyappan**, San Jose, CA (US)

(Continued)

(73) Assignees: **United States of America as Represented by the Administrator of the National Aeronautics and Space Administration**, Washington, DC (US); **NanoConduction, Incorporated**, Los Gatos, CA (US)

FOREIGN PATENT DOCUMENTS

EP 1329953 8/2003

(Continued)

(*) Notice: Subject to any disclaimer, the term of this patent is extended or adjusted under 35 U.S.C. 154(b) by 0 days.

OTHER PUBLICATIONS

Banerjee, Kaustav, et al., "3-D Heterogeneous ICs: A Technology for the Next Decade and Beyond", *5th IEEE Workshop on Signal Propagation on Interconnects*, Venice, Italy, May 13-16, 2001.

(21) Appl. No.: **10/825,795**

(22) Filed: **Apr. 13, 2004**

(Continued)

(65) **Prior Publication Data**
US 2005/0224220 A1 Oct. 13, 2005
US 2007/0163769 A9 Jul. 19, 2007

Primary Examiner—Teresa J. Walberg
(74) *Attorney, Agent, or Firm*—John F. Schipper; Robert M. Padilla

(51) **Int. Cl.**
F28F 13/00 (2006.01)
(52) **U.S. Cl.** **165/185; 165/80.3**
(58) **Field of Classification Search** 165/185,
165/80.3; 361/704
See application file for complete search history.

(57) **ABSTRACT**

A method for providing for thermal conduction using an array of carbon nanotubes (CNTs). An array of vertically oriented CNTs is grown on a substrate having high thermal conductivity, and interstitial regions between adjacent CNTs in the array are partly or wholly filled with a filler material having a high thermal conductivity so that at least one end of each CNT is exposed. The exposed end of each CNT is pressed against a surface of an object from which heat is to be removed. The CNT-filler composite adjacent to the substrate provides improved mechanical strength to anchor CNTs in place and also serves as a heat spreader to improve diffusion of heat flux from the smaller volume (CNTs) to a larger heat sink.

(56) **References Cited**
U.S. PATENT DOCUMENTS

4,485,429 A *	11/1984	Mittal	361/718
5,316,080 A *	5/1994	Banks et al.	165/185
5,725,707 A *	3/1998	Koon et al.	156/157
5,818,700 A *	10/1998	Purinton	361/760
5,837,081 A *	11/1998	Ting et al.	156/89.26
5,898,570 A *	4/1999	Koon et al.	165/185
5,926,370 A	7/1999	Cromwell	
5,965,267 A	10/1999	Nolan et al.	
6,156,256 A	12/2000	Kennel	

30 Claims, 7 Drawing Sheets

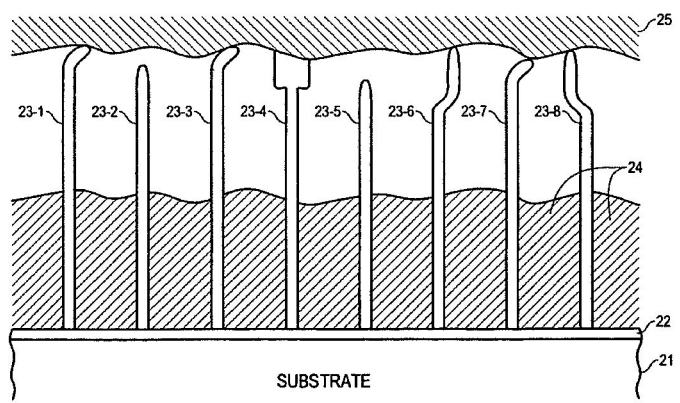

U.S. PATENT DOCUMENTS

6,359,288	B1	3/2002	Ying et al.	
6,383,923	B1	5/2002	Brown et al.	
6,407,922	B1	6/2002	Eckblad et al.	
6,432,740	B1	8/2002	Chen	
6,452,274	B1	9/2002	Hasegawa et al.	
6,504,292	B1 *	1/2003	Choi et al.	313/310
6,538,367	B1	3/2003	Choi et al.	
6,713,151	B1 *	3/2004	Dean et al.	428/86
6,800,886	B2	10/2004	Awano	
6,803,260	B2	10/2004	Shin et al.	
6,831,017	B1	12/2004	Li et al.	
6,855,376	B2	2/2005	Hwangg et al.	
6,856,016	B2	2/2005	Searls et al.	
6,956,016	B2	2/2005	Searls et al.	
6,864,571	B2	3/2005	Arik et al.	
6,891,724	B2 *	5/2005	De Lorenzo et al.	165/185
6,921,462	B2	7/2005	Montgomery et al.	
6,924,335	B2	8/2005	Fan et al.	
6,958,216	B2	10/2005	Kelley et al.	
6,962,823	B2	11/2005	Empedocles et al.	
6,965,513	B2	11/2005	Montgomery et al.	
6,989,325	B2	1/2006	Uang et al.	
2002/0090501	A1	7/2002	Tobita	
2002/0100581	A1 *	8/2002	Knowles et al.	165/185
2002/0130407	A1	9/2002	Dahl et al.	
2002/0145194	A1	10/2002	O'Conner et al.	
2002/0163079	A1	11/2002	Awano	
2003/0111333	A1	6/2003	Montgomery et al.	
2003/0117770	A1	6/2003	Montgomery et al.	
2003/0189202	A1	10/2003	Li et al.	
2003/0231471	A1	12/2003	De Lorenzo et al.	
2004/0005736	A1	1/2004	Searls et al.	
2004/0013598	A1	1/2004	McElrath et al.	
2004/0053053	A1	3/2004	Jiang et al.	
2004/0099208	A1	5/2004	Kang et al.	
2004/0101468	A1	5/2004	Liu et al.	
2004/0146560	A1	7/2004	Whiteford et al.	
2004/0150100	A1	8/2004	Dubin et al.	
2004/0150311	A1	8/2004	Jin	
2004/0152240	A1 *	8/2004	Dangelo	438/122
2004/0182600	A1	9/2004	Kawabata et al.	
2004/0184241	A1	9/2004	De Lorenzo et al.	
2004/0191158	A1	9/2004	Liu et al.	
2004/0218362	A1	11/2004	Amaro et al.	
2004/0250753	A1	12/2004	Kang et al.	
2004/0261978	A1	12/2004	Zhan et al.	
2004/0261987	A1	12/2004	Zhang et al.	
2004/0265489	A1	12/2004	Dubin	
2004/0266063	A1	12/2004	Montgomery et al.	
2004/0266065	A1	12/2004	Zhang et al.	
2005/0006754	A1	1/2005	Arik et al.	
2005/0037204	A1	2/2005	Oslander et al.	
2005/0046017	A1	3/2005	Dangelo	
2005/0061496	A1	3/2005	Matabayas	
2005/0067693	A1	3/2005	Nihei et al.	
2005/0092464	A1	5/2005	Leu et al.	
2005/0116336	A1	6/2005	Chopra et al.	
2005/0136248	A1	6/2005	Leu et al.	
2005/0139642	A1	6/2005	Koning et al.	
2005/0139991	A1	6/2005	White et al.	
2005/0150887	A1	7/2005	Taya et al.	
2005/0167647	A1	8/2005	Huang et al.	
2005/0224220	A1	10/2005	Li et al.	
2005/0238810	A1	10/2005	Scaringe et al.	
2005/0260412	A1	11/2005	Gardner	
2005/0269726	A1	12/2005	Matabayas, Jr.	

FOREIGN PATENT DOCUMENTS

EP	1329953	A1	8/2003
WO	03/054958	A1	7/2003

WO	2003/054958	7/2003
WO	03/072679	A1 9/2003
WO	2003/072679	9/2003
WO	03/107419	A1 12/2003
WO	2003/107419	12/2003

OTHER PUBLICATIONS

- Berber, et al., Unusually High Thermal Conductivity of Carbon Nanotubes, *Physical Review Letters*, May 15, 2000, 4613-4616, vol. 84, No. 20.
- Cassell, Alan, "Directed Growth of Free-Standing Single-Walled Carbon Nanotubes", *J. Am. Chemical Society*, 1999, 121 pp. 7975-7976.
- Chiang, Ting-Yen, "A New Analytical Thermal Model for Multi-level ULSI Interconnects Incorporating Via Effect", Center for Integrated Systems, Stanford University (no date given).
- Chiang, Ting-Yen, et al., "Effect of Via Separation and Low-k Dielectric Materials on the Thermal Characteristics of Cu Interconnects", *IEDM 2000* (no date).
- Chuang, Helen F., et al., "Improvement of Thermal Contact Resistance by Carbon Nanotubes and Nanofibers," *Journal of Nanoscience and Nanotechnology* (2004), vol. 4, No. 8, pp. 964-967, American Scientific Publishers.
- Cui, Yi, et al., "Doping and Electrical Transport in Silicon Nanowires", *Journal of Physical Chemistry*, vol. 104, No. 22, Jun. 8, 2000, pp. 5213-5216.
- de Pablo, P.J., "A simple, reliable technique for making electrical contact to multiwalled carbon nanotubes", *Applied Physics Letters*, vol. 74, No. 2, Jan. 11, 1999, pp. 323-325.
- Delzeit, Lance, et al., "Growth of carbon nanotubes by thermal and plasma chemical vapour deposition processes and applications in microscopy", *Nanotechnology*, vol. 13, May 23, 2002, pp. 280-284.
- Delzeit, Lance, et al., "Growth of multiwall carbon nanotubes in an inductively coupled plasma reactor", *Journal of Applied Physics*, vol. 91, No. 9, May 1, 2002, pp. 6027-6033.
- Goodson, K.E., et al., "Improved Heat Sinking for Laser-Diode Arrays Using Microchannels in CVD Diamond", *IEEE Transactions on Components, Packaging, and Manufacturing Technology*, Part B, *Advanced Packaging*, vol. 20, Issue 1, Feb. 1997, pp. 104-109.
- Hone, J., et al., "Thermoelectric Power of Single-Walled Carbon Nanotubes", *Physical Review Letters*, vol. 80, No. 5, Feb. 2, 1998, pp. 1042-1045.
- Huang, Z.P., et al., "Growth of highly oriented carbon nanotubes by plasma-enhanced hot filament chemical vapor deposition", *Applied Physics Letters*, vol. 73, No. 26, Dec. 28, 1998, pp. 3845-3847.
- International Semiconductor Road Map (ITRS-2001)*, Section on Interconnect, <http://public/itrs.net/files/2001ITRS/interconnect.pdf>.
- Kim, Mun Ja, et al., "Growth characteristics of carbon nanotubes via aluminum nanopore template on Si substrate using PECVD", *Elsevier Thin Solid Films*, vol. 425, 2003, pp. 312-317.
- Kong, Jing, et al., "Synthesis of individual single-walled carbon nanotubes on patterned silicon wafers", *Nature*, vol. 395, Oct. 29, 1998, pp. 878-881.
- Kurabayashi, K., et al., "Precision Measurement and Mapping of Die-Attach Thermal Resistance", *IEEE Transactions on Components, and Manufacturing Technology*, Part A: *Advanced Packaging*, vol. 21, Issue 3, Sep. 1998, pp. 506-514.
- Li, Jun, et al., "Electronic properties of multiwalled carbon nanotubes in an embedded vertical array", *Applied Physics Letters*, vol. 81, No. 5, Jul. 29, 2002, pp. 910-912.
- Li, Jun, et al., Bottom Up Approach for Carbon Nanotube Interconnects, *Applied Phys. Letters*, Apr. 18, 2003, 2491-2493, vol. 82, No. 15, American Institute of Physics.
- Liu, Jie, et al., "Controlled deposition of individual single-walled carbon nanotubes on chemically functionalized templates", *Chemical Physics Letters*, 303, Apr. 2, 1999, pp. 125-129.
- McEuen, Paul L., et al., "Single-Walled Carbon Nanotube Electronics", *IEEE Transactions on Nanotechnology*, vol. 1, No. 1, Mar. 2002, pp. 78-85.
- Meyyappan, M., et al., "Carbon nanotube growth by PECVD: a review", *Plasma Sources Science and Technology*, vol. 12, Apr. 2, 2003, pp. 205-216.

- Ren, Z.F., et al., "Synthesis of Large Arrays of Well-Aligned Carbon Nanotubes on Glass", *Science*, vol. 282, Nov. 6, 1998, pp. 1105-1107.
- Shi, Li., "A Microdevice for Measuring Thermophysical Properties of Nanowires and Nanotubes", *2001 ASME International Mechanical Engineering Congress and Exposition*, Nov. 11-16, 2001, pp. 359-362.
- Shi, Li., "Scanning thermal microscopy of carbon nanotubes using batch-fabricated probes", *Applied Physics Letters* vol. 77, No. 26, Dec. 25, 2000, pp. 4295-4297.
- Stevens, R., "Improved fabrication approach for carbon nanotube probe devices", *Applied Physics Letters*, vol., 77, No. 21, Nov. 20, 2000, pp. 3453-3455.
- Sun, X., et al., "Theoretical modeling of thermoelectricity in Bi nanowires", *Applied Physics Letters*, vol. 74, No. 26, Jun. 28, 1999, pp. 4005-4007.
- Tu et al., Growth of Aligned Carbon Nanotubes with Controlled Site Density, *Applied Phys. Letters*, May 27, 2002, 4018-4020, vol. 80, No. 21, American Institute of Physics.
- Viswanath, Ram, et al., "Thermal Performance Challenges from Silicon to Systems," *Intel Technology Journal Q3 Microprocessor Packaging*, vol. 4, Issue 3, Aug. 2000.
- Yakobson, Boris I., "Fullerene Nanotubes: C_{1,000,000} and Beyond", *American Scientist online*, <http://www.americanscientist.org/template/AssetDetail/assetid/2870?fulltext=true&print=yes>.
- Zhang, Wei De, et al., "Synthesis of vertically aligned carbon nanotubes films on silicon wafers by pyrolysis of ethylenediamine", *Elsevier. Thin Solid Films*, 422, 2002, pp. 120-125.
- Zhang, Yuegang, et al., "Electric-field-directed growth of aligned single-walled carbon nanotubes", *Applied Physics Letters*, vol. 79, No. 19, Nov. 5, 2001, pp. 3155-3157.
- Zhou, P., et al., "Thermomechanical Diagnostics of FLIP-CHIP/BGA Structures Using Phase-Shifting Electronic Speckle Pattern Interferometry", *EEP, Advances in Electronic Packaging*, vol. 26-2, ASME, 1999, pp. 1875-1880.
- Zhang, Y., et al., "Formation of Metal Nanowires on Suspended Single-Walled Carbon Nanotubes", *Appl. Phys. Lett.*, vol. 77(19), p. 3015 (2000).
- L. Delzeit, et al., "Directed Growth of Single-Walled Carbon Nanotubes" *International Journal of Nanoscience*, 2002, vol. 1, Nos. 3 & 4, 197-204, World Scientific Publishing Co.
- H. Hwang, et al., "Simulations and Experiments of Etching of Silicon in HBr Plasmas for High Aspect Ratio Features," *J. Vac. Sci. Technol.*, 2002, 2199, vol. B 20, Amer Vac Soc.
- B. Wei, R. Vajtai, and P. Ajayan, "Reliability and Current Carrying Capacity of Carbon Nanotubes," *Applied Physics Letters*, Aug. 20, 2001, 1172-1174, vol. 79, No. 8, AIP.
- A. Ural, et al., "Electric-Field-Aligned Growth of Single-Walled Carbon Nanotubes on Surfaces," *Applied Physics Letters*, Oct. 28, 2002, 3464-3466, vol. 81, No. 18, AIP.

* cited by examiner

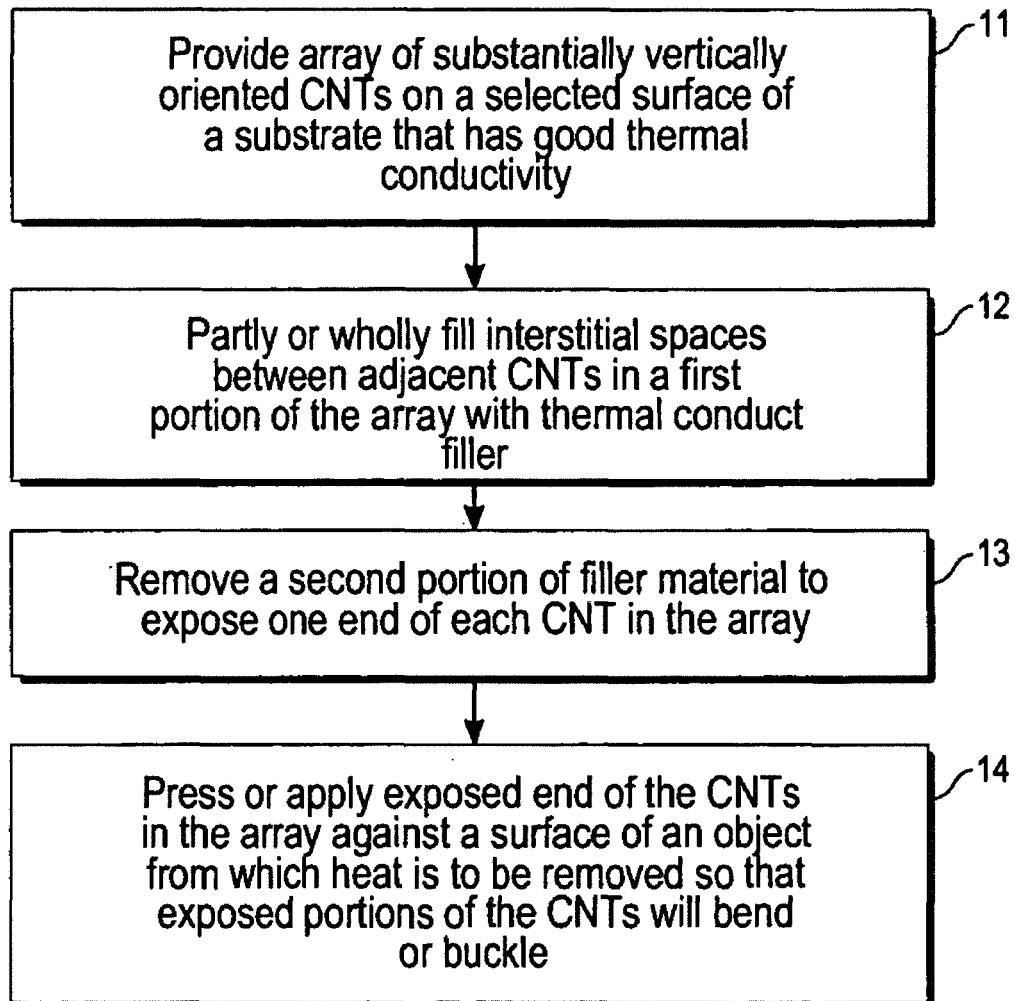
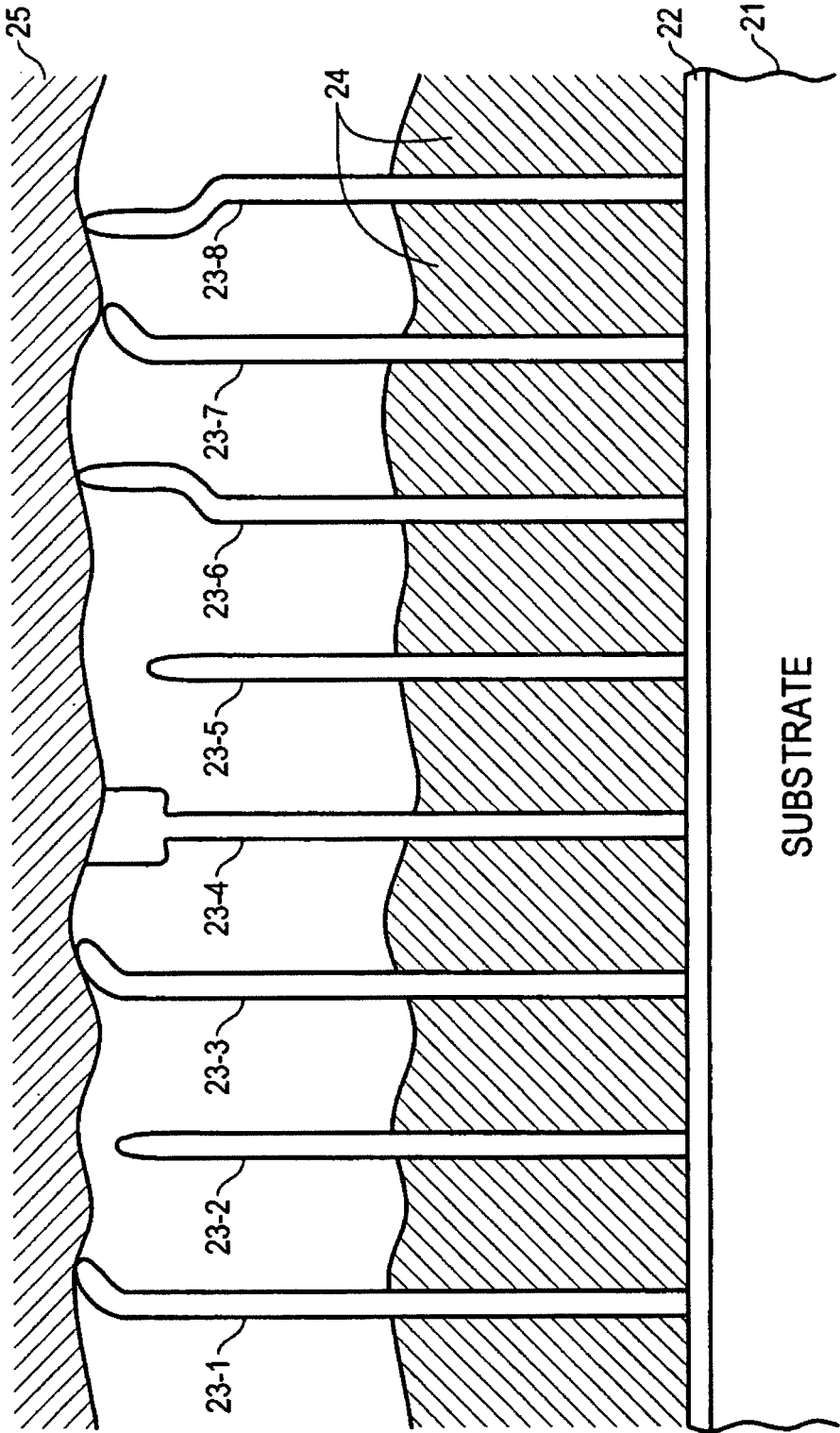

FIG. 1



SUBSTRATE

FIG. 2

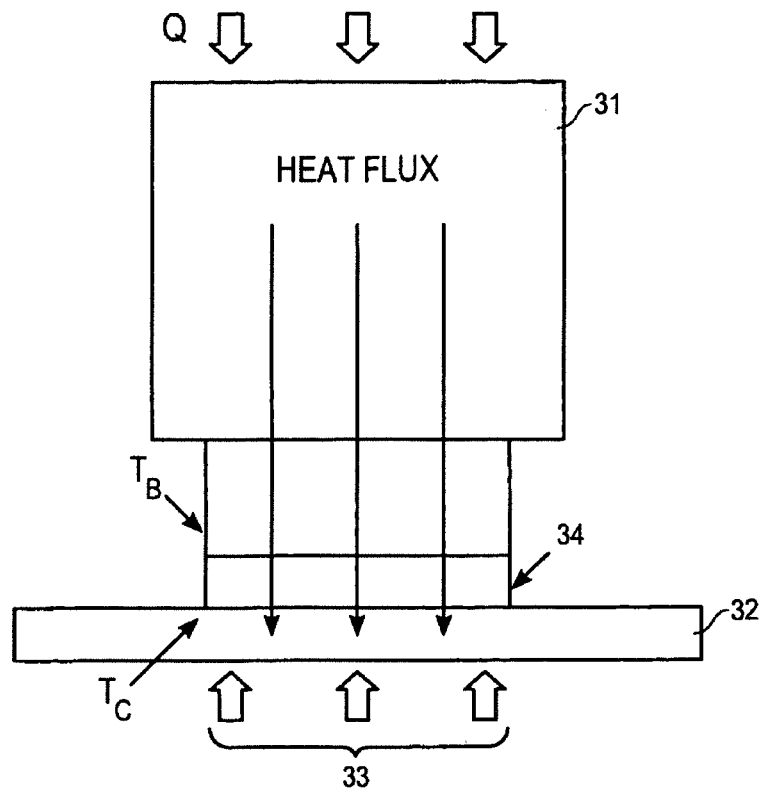

FIG. 3A

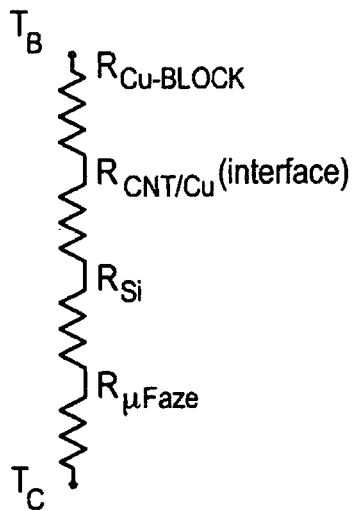

FIG. 3B

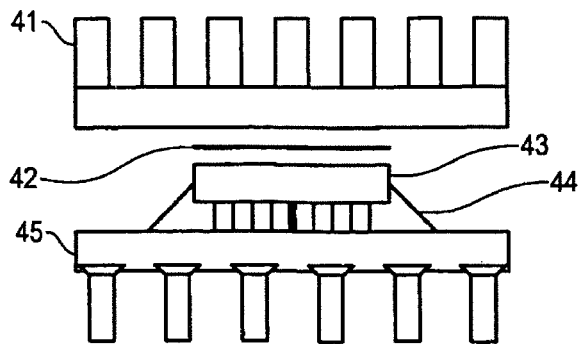

FIG. 3C

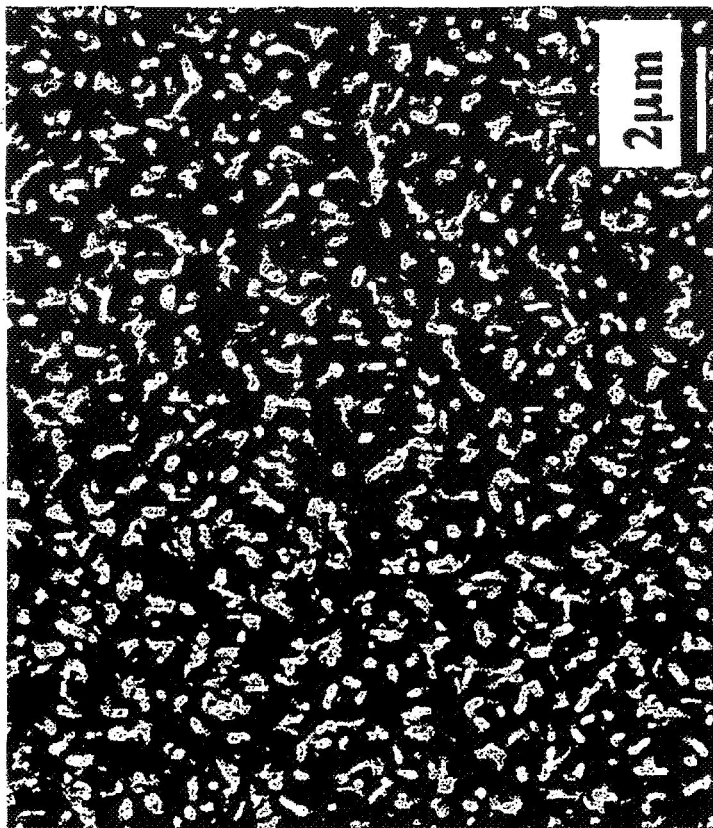

FIG. 4B

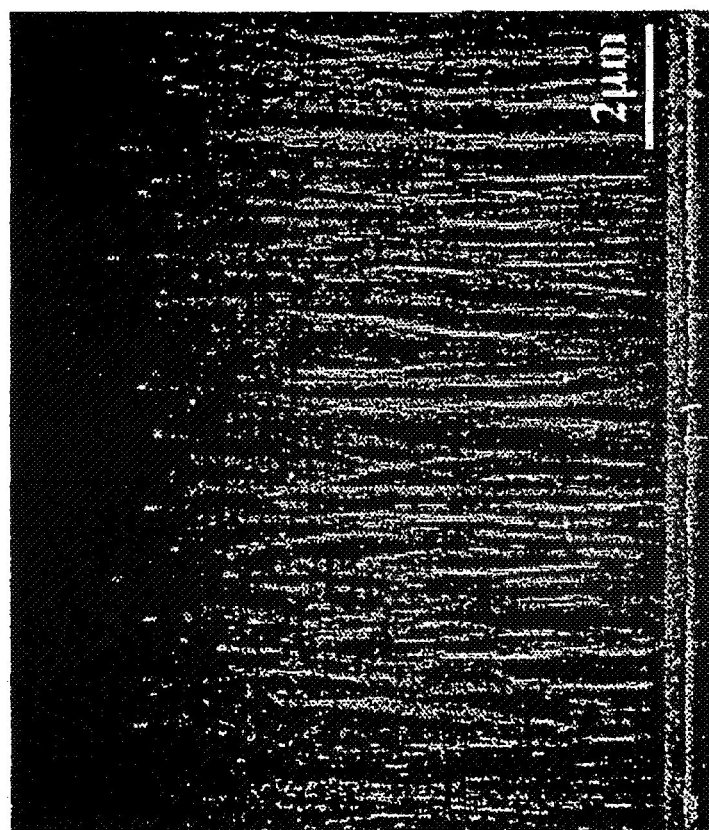

FIG. 4A

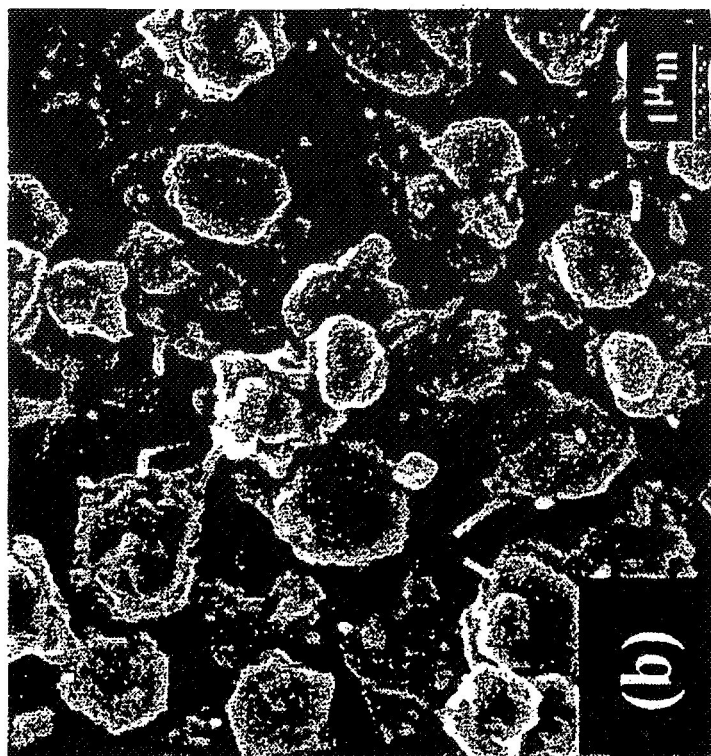

FIG. 5B

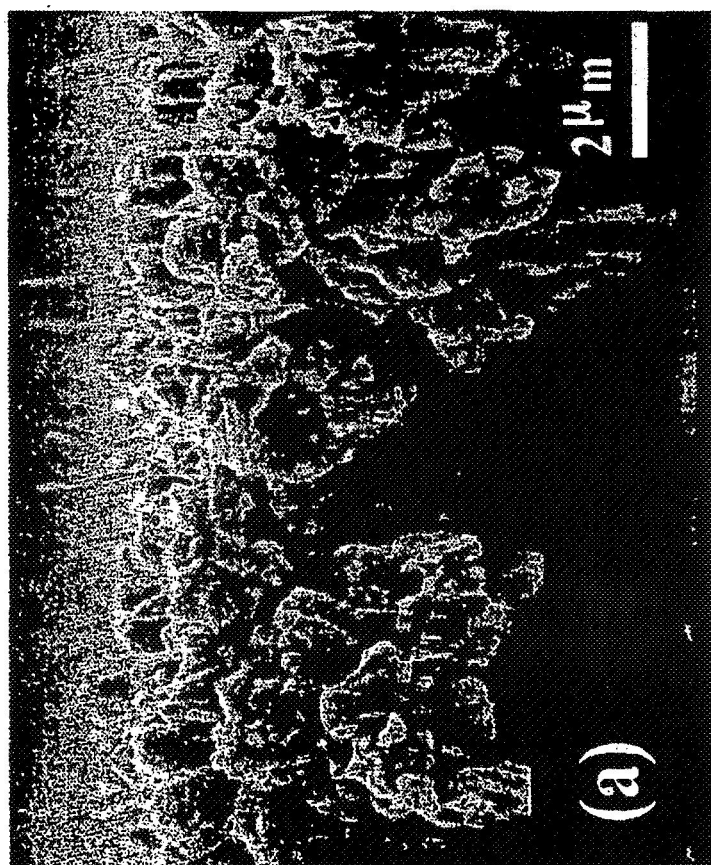

FIG. 5A

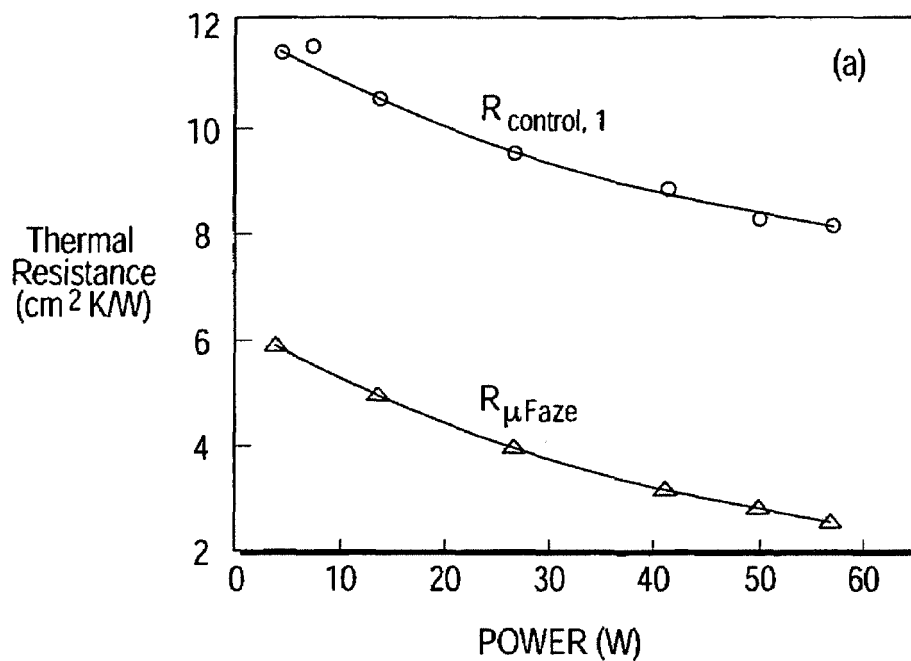

FIG. 6A

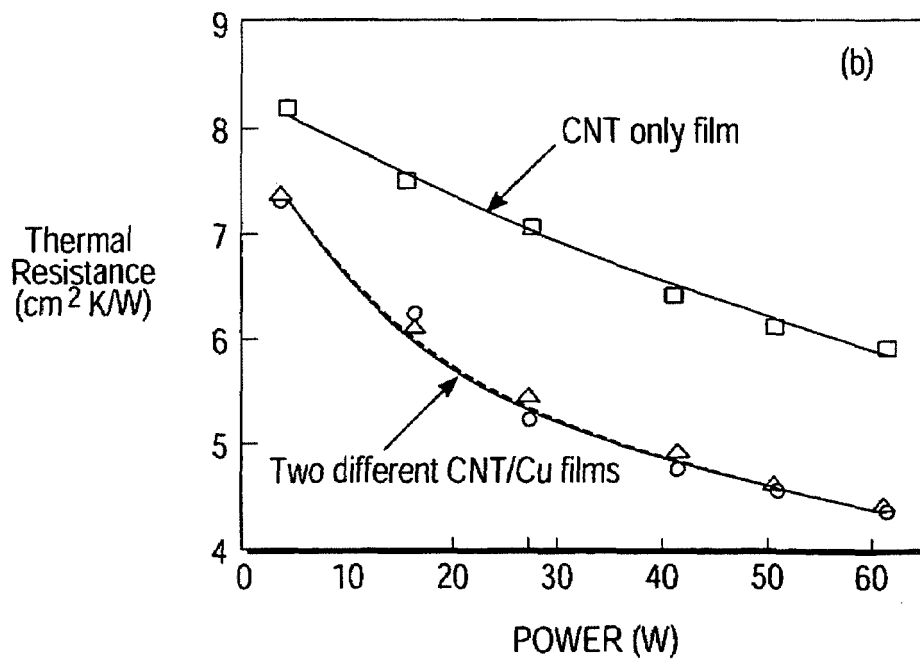

FIG. 6B

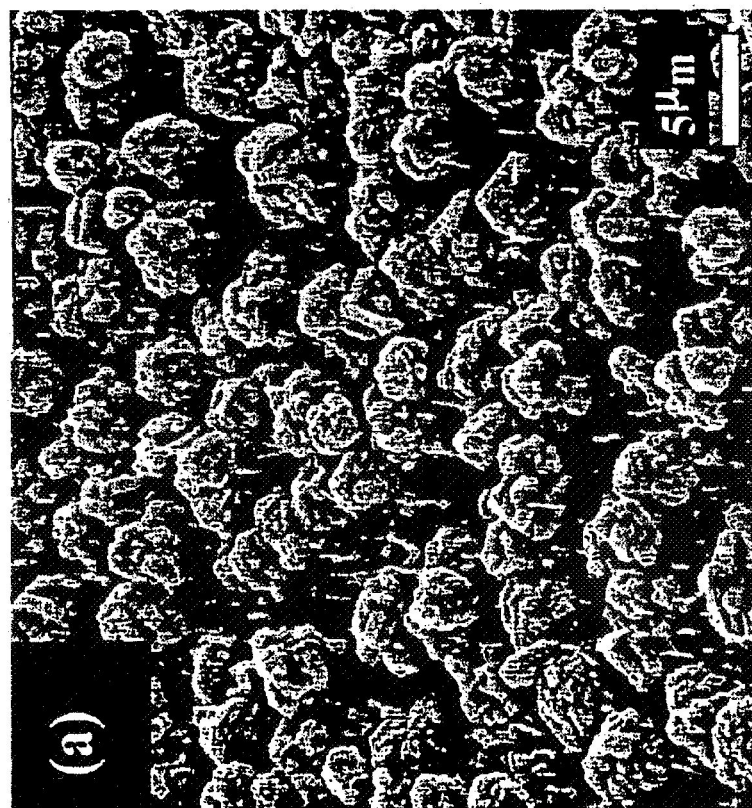
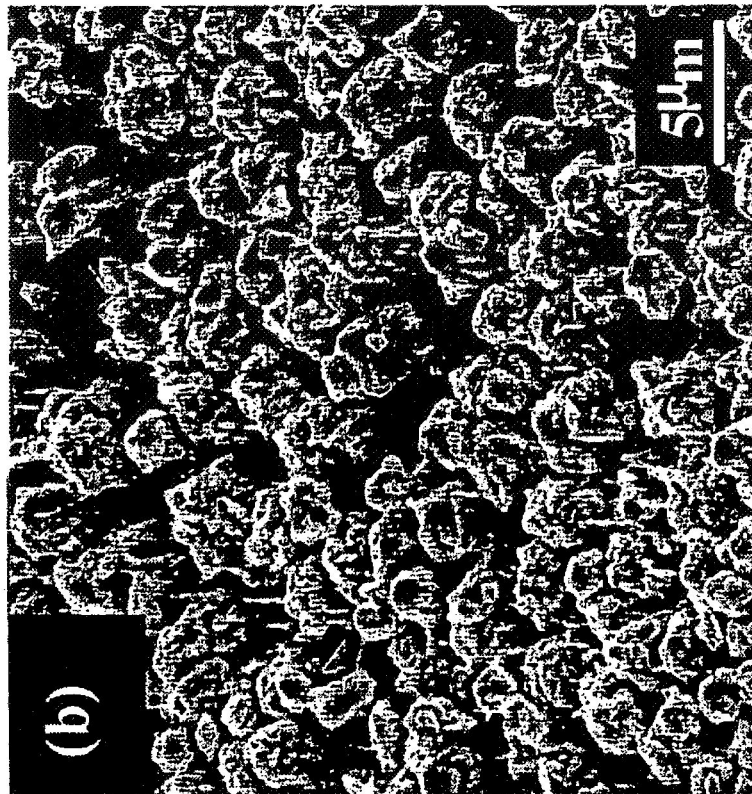

FIG. 7B

FIG. 7A

1

NANOENGINEERED THERMAL MATERIALS BASED ON CARBON NANOTUBE ARRAY COMPOSITES

ORIGIN OF THE INVENTION

The invention described herein was made by employees of the United States Government and may be manufactured and used by or for the Government for governmental purposes without the payment of any royalties thereon or therefor.

CROSS REFERENCE TO RELATED APPLICATIONS

This application is a continuation-in-part of prior filed application Ser. No. 10/390,254, Pat. No. 7,094,679, filed Mar. 11, 2003 and issued Aug. 22, 2006, which is incorporated by reference herein.

TECHNICAL FIELD

The present invention provides thermal conductors for small components and devices, using carbon nanotube arrays.

BACKGROUND OF THE INVENTION

State-of-the-art integrated circuits (ICs) for microprocessors routinely dissipate power densities on the order of 50 Watts/cm². This large power is due to the localized heating of ICs operating at high frequencies, and must be managed for future high-frequency microelectronic applications. As the size of components and devices for ICs and other appliances becomes smaller, it becomes more difficult to provide heat dissipation and transport for such components and devices. A thermal conductor for a macro size thermal conductor is generally inadequate for use with a micro size component or device, in part due to scaling problems.

One consequence of increased component density in, and compactness of, ICs manifests itself in the form of locally high power consumption. An alarming rise in power density with respect to each advancing technology generation has been observed in mainstream microprocessor technologies. The need for addressing this problem is imperative for next-generation IC packaging technology. One potential solution is to find new packaging materials that exhibit high thermal conductivity and that can transfer heat from a local hot spot to a larger heat sink.

The cooling of an object by attaching it to a cold reservoir is normally limited by the heat transfer rate across the interface. Except for objects with atomically flat surfaces, practical objects normally have only a very small portion of surface in contact with other solid surfaces. Eutectic bonding materials or thermal conducting pastes/films are normally applied at the interface to increase the contact area. However, the thermal conductivities of these eutectic bonding materials are normally orders of magnitude lower than those of solid materials such as Cu and Si. The interface thus remains the bottleneck for heat dissipation. Metal film can be used to improve the thermal conductivity but is only applicable for high pressure loading.

What is needed is a compliant thermal interface material that efficiently and promptly dissipates or conducts heat from a micro size component or device, preferably down to nanometer scale systems, to a heat sink with a heat transfer rate that is comparable to rates for macro size components

2

and devices. Preferably, the thermal conductor should be reusable and should work with any surface, rough or smooth.

SUMMARY OF THE INVENTION

These needs are met by the invention, which uses an embedded carbon nanotube array to provide one or more high performance thermal conductors for applications that require large heat dissipation. This approach also improves the mechanical strength of carbon nanotubes (CNTs) so that the CNT array can remain stable and can make good contact to the surface of objects that generate large amount of heat, through use of reversible buckling and bending of exposed portions of the CNTs. The extremely high thermal conductivity along a carbon nanotube axis is employed to transfer heat away from hot spots in a component or device. Copper and other high thermal conductivity materials are deposited to fill interstitial regions or gaps in a first part of a CNT array. This composite structure provides mechanical strength to maintain the CNTs in position and also serves as an efficient heat transfer material to improve diffusion of heat flux from an individual CNT to a larger surrounding volume.

The innovation uses vertically oriented CNT arrays to increase the effective contact area (particularly for a rough surface) while providing an extremely large thermal conductivity along a CNT axis and across the interface. The fabrication involves four steps: (1) substantially vertically aligned CNT arrays with a preferred length of from 1 to 50 microns are grown on a solid substrate (serving as a heat sink) that has good thermal conductivity, such as Si wafers and metal blocks/films; (2) a first portion of, or all of, interstitial spaces between adjacent CNTs are filled with highly thermally conductive materials such as Cu, Ag, Au, Pt or doped Si by chemical vapor deposition (CVD), physical vapor deposition (PVD), plasma deposition, ion sputtering, electrochemical deposition, or casting from liquid phase; (3) filler materials are removed from a second portion of the interstitial spaces by mechanical polishing (MP), chemical mechanical polishing (CMP), wet chemical etching, electrochemical etching, or dry plasma etching so that the top portion of the CNT array is exposed, with the bottom part remaining embedded in the filler materials; and (4) the embedded CNT array is applied against an object that is to be cooled. CNTs can reversibly buckle or bend one by one under low loading pressure so that a CNT can make maximum contact with the object to be cooled, even an object with a very rough surface.

Heat can be effectively transferred from the contacting spots along the tube axis to the filler materials as well as the substrates. The filler materials plays two critical roles: (a) improving the mechanical stability, and (b) maximizing the thermal conductivity. Choosing highly thermal conductive materials as the filler matrix maximizes the heat transfer from the contact spots to the substrate (i.e. the heat sink or cooling reservoir). An embedded CNT array can be reused without damage or compromise of its heat transport characteristics, in contrast to an approach that relies upon eutectic bonding.

The invention improves the mechanical stability of a CNT array by anchoring the lower portion of the array in a solid matrix so that the array retains the integrity when pressed against the heated object during mounting processes. The reversible buckling and bending properties of a CNT array ensures a maximum physical contact under a low loading pressure with the object surface, whether the surface is atomically flat or very rough.

For a discrete multiwall carbon nanotube (MWCNT), the thermal conductivity is expected to surpass 3000 Watts (meter)⁻¹ K⁻¹ along the tube axis, according to P. Kim et al, Phys. Rev. Lett., vol. 87 (2001) 215502-1. Through the use of DC-biased, plasma-enhanced chemical vapor deposition (PECVD), as demonstrated by B. A. Cruden et al, Jour. Appl. Phys., vol. 94 (2003) 4070, one can fabricate vertically aligned MWCNT arrays (sometimes referred to as carbon nanofiber arrays) on silicon wafers of thickness ~500 μm and demonstrate their possible application as a heat-sink device, conducting large amounts of heat away from a localized area, such as in critical "hot spots" in ICs.

This innovation is an outgrowth of an earlier NASA patent application (NASA Ref. No. ARC-15042-1) which uses a CNT array as an electrical interconnect material embedded in an SiO₂ matrix. Here, a highly thermal conductive material, such as Cu, Ag, and/or Si, replaces SiO₂, used to control electrical conduction in the earlier innovation.

BRIEF DESCRIPTION OF THE DRAWINGS

FIG. 1 illustrates a CNT array thermal conduction system constructed according to the invention.

FIG. 2 schematically illustrates use of the invention.

FIGS. 3A and 3C illustrates apparatus used for thermal resistance measurements.

FIG. 3B illustrates a packaging architecture used in the prior art.

FIGS. 4A and 4B are scanning electron microscope (SEM) cross sectional and top-down microphotographs, respectively, of an as-grown multiwall carbon nanotube array.

FIGS. 5A and 5B are SEM cross sectional and top-down photomicrographs, respectively, of a CNT-Cu composite film.

FIGS. 6A and 6B are graphical views of thermal resistance versus electrical power measurements for a first control sample and Microfaze (FIG. 6A) and for a CNT-only film and for two different CNT-Cu films (FIG. 6B).

FIGS. 7A and 7B are SEM photomicrographs of a CNT-Cu film, taken before and after compressive thermal resistance measurements, respectively.

DESCRIPTION OF BEST MODES OF THE INVENTION

FIG. 1 illustrates a procedure for practicing an embodiment of the invention. In step 11, an array of substantially vertically oriented CNTs is grown on a selected surface of a substrate that has good thermal conductivity. The substrate may be a metal-doped silicide, a diamond film, or a metallic substance having a maximum electrical or thermal conductivity. Whether the array is patterned or not, it is preferable to provide a thin CNT catalyst layer (e.g., Ni, Fe, Co, Pd or Al or a combination thereof) having a layer thickness of 2–50 nanometers (nm), or more if desired. When the CNT is grown in an electrical field oriented substantially perpendicular to the selected substrate surface, the CNTs can be grown in greater lengths (1–50 μm or more) in a direction substantially parallel to the electrical field direction.

In step 12, interstitial spaces between adjacent CNTs are partly or fully filled with a selected filler material that is preferably a good thermal conductor (e.g., Cu, Ag, Au or metal-doped silicon), in order to augment the transport of heat, using chemical vapor deposition (CVD), physical vapor deposition (PVD), plasma deposition, ion sputtering,

electrochemical deposition, or casting from liquid phase. Depending upon the density of CNTs in the array and the filler material, the thermal conductivity of the system is estimated to be in a range of 100–3000 Watts/(meter)-K, which is comparable to the thermal conductivity of oriented graphite.

In step 13, a top portion of the filler material is removed by mechanical polishing (MP), chemical mechanical polishing (CMP), wet chemical etching, electrochemical etching, dry plasma etching, or a combination thereof so that the top portion of the CNT array is exposed.

In step 14 (optional), the thermal conduction system provided by the steps 11, 12 and 13 is pressed or otherwise applied to a surface (atomically smooth, rough or somewhere in between) of an object from which heat is to be removed so that the exposed portions of the CNTs will bend or buckle.

FIG. 2 schematically illustrates use of the system produced by the procedure of FIG. 1 to remove heat from an object 25. An array of CNTs 23-i (i=, . . . , I (I=8 in FIG. 2)) is grown or otherwise provided on a selected surface of a substrate 21 having an optional catalyst layer 22. A layer of filler material 24, having a depth that allows exposure of an upper portion of each CNT 23-i, is provided, for mechanical strengthening of the CNTs and for improved diffusion of heat that initially travels only along the CNTs (from the object 25). The CNTs 23-i are pressed against a surface of an object 25, from which heat is to be removed, so that many or all of the CNTs make contact with the (rough) object surface and either bend (23-1, 23-3 and 23-7) or buckle (23-4, 23-6 and 24-8) in order to improve heat transport from the object.

A measurement apparatus, illustrated in FIG. 3A, including two copper blocks, 31 and 32, four resistive cartridge heaters (not shown) embedded in the upper block, and a cooling bath 33, is used to measure the thermal resistance of a given material. The upper copper block 31 is preferably surrounded by insulation (not shown) to minimize heat loss to the ambient, with the exception of the one square inch section designed to contact the material 34 to be measured. The clamping pressure on the sample is controlled by pneumatically manipulating the upper block. Heat is delivered to the system by applying a constant power to the cartridge heaters. The steady state temperature difference ($\Delta T = T_B - T_C$) between the two blocks, 31 and 32, with the intervening sample 34, was measured. From these data, the thermal resistance R of the sample is calculated, as in Eq. (1), where Q is the total power (in Watts), A is the sample cross-sectional area, C_L is the constant heat transfer coefficient and T_B, T_C, and T_{amb} represent the temperature of the upper block 31, the chilled lower block 32 (T_c=20° C.), and the ambient environment, respectively. The heat transfer coefficient C_L is used to estimate the heat loss to the ambient environment in this measurement configuration and is determined by placing a thick insulator between the two blocks and measuring the steady state ΔT at a variety of applied powers. This analysis yields a constant heat transfer coefficient of C_L=0.0939 Watts/K, which is factored into the final determination of the measured thermal resistance R. This coefficient C_L represents the heat power lost (in Watts) per degree Kelvin to the ambient environment.

$$R = \frac{A(T_B - T_C)}{Q - C_L(T_B - T_{amb})} \quad (1)$$

The dominant thermal resistance mechanism in this measurement configuration is that of the contact interfaces between the sample **34** and the copper blocks, **31** and **32**. To minimize this contact resistance, two steps were taken: (1) polishing both copper blocks, **31** and **32**, to reduce the effect of surface roughness and (2) making use of a high thermally conductive, conformal material, Microfaze A6 (available from AOS Thermal Compounds, LLC, New Jersey) to reduce contact resistance on the backside of a silicon wafer, the substrate on which the investigated films were fabricated.

Sample Preparation

Carbon nanotubes were synthesized using the procedure and reactor conditions reported by B. A. Cruden et al, op cit. The resulting as-grown tubes are shown in cross section and top views in FIGS. **4A** and **4B**, respectively. Using scanning electron microscope (SEM) data, we estimate the length of the MWCNTs to be about 7.5 μm , with a possible range of 1–50 μm .

Following nanotube synthesis, a high thermal conductivity metal-like substance (e.g., Cu, Ag, Au, Pt or Pd) between individual MWCNTs (also referred to as nanotube trenches) was deposited through electrodeposition, using a three-electrode setup with a one cm^2 MWCNT array as the working electrode, a Saturated Calomel Electrode (SCE) as the reference electrode, and a one square inch platinum foil as the counter electrode (CE), set in parallel with the MWCNT sample. Both the Cu substrate and the MWCNTs serve as electrodes during the electrodeposition.

Various additives are optionally added to the solution to achieve optimum gap filling into the high-aspect-ratio, forest-like MWCNT arrays. The recipe of the electrolyte solution used in this study is based on the methodology reported for deep-trench filling of Cu interconnects for damascene processes, as reported by K. Kondo et al, Jour. Electroanalytical Chem., vol. 559(2003) 137. We begin with a stock solution comprised of copper sulfate ($\text{CuSO}_4 \cdot 5\text{H}_2\text{O}$), sulfuric acid (H_2SO_4), and sodium chloride (NaCl). Polyethylene glycol (PEG) is added to inhibit copper deposition at the tips of the nanotubes when in the presence of Cl^- ions. Janus Green B (JGB) is also added for its deposition inhibiting properties. Bis(3-sulfopropyl)disulfide (SPS) is included to increase local current density at the bottom of the nanotube trenches, thus enhancing the superfilling of high-aspect ratio trenches. The final solution, including concentrations used in the bath, is shown in Table I. Typically, the Cu was deposited at -0.20 to -0.30 V (vs. SCE) at a deposition rate of about 430 nm/min. The resulting CNT-Cu composite material is shown in FIGS. **5A** and **5B**.

FIG. **3C** illustrates typical packaging architecture, as discussed by R. Viswanath et al, Intel Tech. Jour Q3 (2000), including a heat sink (fins and heat spreader) **41** are contiguous to a thin interface (phase change film, grease, etc.) **42**, which is contiguous to a thin silicon layer **43**. A heat delivery array **45** contacts the silicon array back surface **43** through a conductive gel or epoxy **44**. This system requires use of greases, phase change films, thermally conductive gels and/or special epoxies and is quite complex.

TABLE I

Electrochemical bath composition for copper deposition	
Bath Chemical/Additive (concentration unit)	Concentration
$\text{CuSO}_4 \cdot 5\text{H}_2\text{O}$ (mol/L)	0.6
H_2SO_4 (mol/L)	1.85
NaCl (ppm)	100
PEG, molar mass: 8000 (ppm)	400
JGB (ppm)	10
SPS (ppm)	10

Results and Discussion

To summarize the structure used, FIG. **3B** illustrates the equivalent thermal resistance model for the CNT-Cu composite sample. The resistance of the CNT-Cu composite can be obtained by de-embedding the thermal resistance contribution of the copper block ($R_{\text{Cu-block}}$), silicon wafer (R_{Si}), and the Microfaze material ($R_{\mu\text{Faze}}$). The thermal resistance of the copper block, $R_{\text{Cu-block}}$, must be taken into account due to the placement of the thermocouple (approximately one inch from the copper block surface). From bulk calculations, $R_{\text{Cu-block}}$ for this configuration can be estimated as 0.95 $\text{cm}^2\text{K/Watt}$. To summarize, one can determine the resistance of the CNT/Cu composite film by Eq. (2).

$$R_{\text{CNT/Cu}} = R_{\text{total}} - R_{\text{Cu-block}} - R_{\text{Si}} - R_{\mu\text{Faze}} \quad (2)$$

$R_{\mu\text{Faze}}$ is determined using two control measurements. The first measurement involves measuring the thermal resistance of a piece of silicon with Microfaze on the backside of the wafer, resulting in $R_{\text{control}} = R_{\text{Cu-block}} + R_{\text{block-Si}} + R_{\mu\text{Faze}}$, where $R_{\text{block-Si}}$ is the interface resistance between the copper block and silicon wafer. The second resistance measurement involves a piece of double-sided polished silicon, resulting in $R_{\text{control,2}} = 2R_{\text{block-Si}} + R_{\text{Si}}$. Assuming that both Si—Cu interfaces in the second control measurement are similar, one can divide this value in half and use the simple relation in Eq. (3).

$$R_{\mu\text{Faze}} = R_{\text{control,1}} - (R_{\text{control,2}} - R_{\text{Si}})/2 - R_{\text{Cu-block}} \quad (3)$$

The intrinsic silicon contribution (R_{Si}) to the thermal resistance in Eqs. (2) and (3) can be neglected. For the 500 μm thick silicon wafer used in this study, the intrinsic silicon thermal resistance can be calculated as 0.034 $\text{cm}^2\text{K/Watt}$, which is two orders of magnitude less than the final measured values of the CNT-Cu sample, and is thus negligible. One caveat to this analysis is in regards to the thermal resistance of Microfaze with respect to the amount of power applied to the upper block. The thermal resistance of the first control sample decreases approximately exponentially with increasing power, corresponding to different temperature gradients, but can be corrected for in the final analysis as will be demonstrated. The double-sided, polished silicon sample shows no power dependence and exhibits a substantially constant resistance of $R = 11.10 \text{ cm}^2\text{K/Watt}$, resulting in 5.55 $\text{cm}^2\text{K/Watt}$ per silicon interface. Subtracting the silicon resistance, which is constant with respect to applied power, one can also determine $R_{\mu\text{Faze}}$ at different powers. The power dependence of the Microfaze is illustrated in FIG. **6A**.

Now that the power dependence of the Microfaze material is quantified, one proceeds with the analysis of the CNT/Si/Microfaze and CNT-Cu/Si/Microfaze stacks. From the previous discussion, one expects these samples to exhibit the

same power dependence, which indeed is the case and is clearly seen in FIG. 6B. Combining the power dependence with the measurements in FIG. 6B we summarize the values of measured thermal resistance in Table II. All measurements were performed at similar clamp pressures, 6.8 psi. Errors contributing to the standard deviation in the measurements can be attributed primarily to two factors: (1) variations in contact area due to varying CNT length distribution (see FIG. 4A); and (2) variations in measurement of total power, ΔT , and ambient temperature loss. However, even at the upper bounds of the measured thermal resistance values for the CNT-Cu composite films, this worst-case scenario represents values that are on the order of the thermal budgets for a variety of commercial microprocessor systems.

TABLE II

Thermal Resistance Measurement Summary	
Material	Thermal Resistance (cm ² K/W) \pm STDEV
CNT film	2.30 \pm 0.33
CNT-Cu composite film (#1)	0.84 \pm 0.22
CNT-Cu composite film (#2)	0.92 \pm 0.13
Bare double-sided silicon	11.10 \pm 0.65

The Cu deposited in the MWCNT array used in this study was not a solid film. Instead, the Cu forms a porous film with ~70% Cu and CNTs and ~30% voids. This configuration increases the mechanical strength so that the sample can be repeatedly and reproducibly measured under different clamping pressures. In addition, this configuration provides spaces so that the composite film can be deformed to make maximal contact with the hot surface. However, studies conducted on the buckling force of discrete MWCNTs, by H Dai et al, Nature, vol. 384 (1996) 147, by H. Dai et al, Appl. Phys. Lett. Vol. 73 (1998) 1508, and by J. Li et al (Surf. And Interf. Analysis, vol. 28 (1999) 8, demonstrate the tremendous amount of force per unit cross sectional area that these structures can withstand. Based on this analysis, we speculate that most nanotubes do not buckle under the force applied in this preliminary study, which is roughly two orders of magnitude less than the calculated CNT buckling force. SEM characterization before and after the thermal resistance measurement (FIGS. 7A and 7B, respectively) shows no effect on the CNT-Cu composite after compressive stress. This approach assumes that most CNTs are bent or buckled to give maximum contact under low pressure (no more than 20 psi in IC packaging), which pressure can be achieved by suitable choice of length and diameter of exposed portions of the CNTs

The thermal resistance at the interface can be further reduced by optimizing the invented interface materials and packaging technology. More particularly, the contact area at low loading pressure (less than 20 psi) can be increased by optimizing the length of the exposed CNTs (which results in lower buckling and bending force). The thermal conductivity of Cu filled in interstitial space can be also increased by improving the integrity of the Cu material. With such optimization implemented, the thermal resistance is expected to be reduced below 0.1 cm²K/Watt which is even better than eutectic binding used today, and can be efficiently used for heat dissipation over 100 Watts/cm² for future IC chips.

These preliminary results demonstrate the fundamental usefulness of CNTs and CNT-Cu composite films as efficient

heat conductors. Our analysis confirms that these novel thermal conductivity layers can accomplish effective heat conduction by increasing contact area. In addition, the CNTs provide the added benefits of high mechanical stability and reusability.

What is claimed is:

1. A method for providing for transport of thermal energy from an object, the method comprising:

providing an array of carbon nanotubes or carbon nanofibers, referred to herein as "CNTs," embedded in or connected to a selected surface of a selected substrate having high thermal conductivity, where at least first and second CNTs in the array are adjacent to and oriented substantially perpendicular to the selected surface;

after provision of the at least first and second CNTs in the array, filling at least a portion of an interstitial space between the at least first and second CNTs in the array with a selected filler material that has high thermal conductivity so that the filler material makes contact with the selected substrate surface at a first end of each of the at least first and second CNTs and a second end of each of the at least first and second CNTs is exposed and is not fully covered by the filler material; and

causing the exposed second ends of the at least first and second CNTs to make contact with a surface of an object for which transport of the thermal energy is to be provided so that at least one of the exposed second ends of the CNTs bends or buckles, whereby thermal energy is removed from the object through the at least first and second CNTs and a portion of the removed thermal energy is distributed within the filler material.

2. The method of claim 1, further comprising selecting said filler material to include at least one of Cu, Ag, Au, Pt, Pd and a metal-doped silicide.

3. The method of claim 1, further comprising providing a layer of a selected catalyst, including at least one of Ni, Fe, Co, Pt and Al, for growth of said array of said CNTs, on said selected surface of said catalyst.

4. The method of claim 1, further comprising filling said portion of said interstitial space with said filler material by a process comprising at least one of chemical vapor deposition, physical vapor deposition, plasma deposition, ion sputtering, electrochemical deposition and casting from a liquid phase.

5. The method of claim 1, further comprising providing said exposed second ends of said at least first and second CNTs by a process comprising at least one of mechanical polishing, chemical-mechanical polishing, wet chemical etching, electrochemical etching and dry plasma etching.

6. The method of claim 1, further comprising providing said exposed ends of said first and second CNTs in said array with an exposed first length and an exposed second length, respectively, that are not covered by said filler material, where the exposed first length and the exposed second length are substantially equal.

7. The method of claim 1, further comprising providing said exposed ends of said first and second CNTs in said array with an exposed first length and an exposed second length, respectively, that are not covered by said filler material, where the exposed first length is greater than the exposed second length.

8. The method of claim 1, further comprising providing for said transport of said thermal energy from said object with an associated thermal resistance of no more than about 0.1 cm²-K/Watt.

9. The method of claim 1, further comprising providing for said transport of said thermal energy from said object with an associated thermal resistance of no more than about $0.1 \text{ cm}^2\text{-K/Watt}$.

10. The method of claim 1, further comprising removing said thermal energy from said object initially through said exposed second ends of said at least first and second CNTs in contact with said object, and subsequently through said filler material that makes contact with said at least first and second CNTs.

11. The method of claim 1, further comprising removing said thermal energy from said object contemporaneously through said exposed second ends of said at least first and second CNTs in contact with said object and through said filler material that makes contact with said at least first and second CNTs.

12. The method of claim 1, further comprising providing said object with a surface for said contact that is rough on an atomic scale and is not substantially planar.

13. Apparatus for providing for transport of thermal energy from an object, the apparatus comprising:

an array of carbon nanotubes or carbon nanofibers, referred to herein as "CNTs," embedded in or connected to a selected surface of a selected substrate having high thermal conductivity, where at least first and second CNTs in the array are adjacent to and are oriented substantially perpendicular to the selected surface;

a high thermal conductivity material that fills at least a portion of an interstitial space between at least the at least first and second CNTs in the array so that the filler material makes contact with the selected substrate surface at a first end of each of the at least first and second CNTs and a second end of each of the at least first and second CNTs is exposed and is not fully covered by the filler material; and

wherein the exposed second ends of the at least first and second CNTs make contact with a surface of an object for which transport of thermal energy is to be provided so that at least one of the exposed second ends of the CNTs bends or buckles, whereby thermal energy is removed from the object through the at least first and second CNTs and a portion of the removed thermal energy is distributed within the filler material.

14. The apparatus of claim 13, wherein said filler material includes at least one of Cu, Ag, Au, Pt, Pd and a metal-doped silicide.

15. The apparatus of claim 13, further comprising a layer of a selected catalyst, including at least one of Ni, Fe, Co, Pt and Al, deposited on said selected substrate surface for growth of said array of said CNTs, on said selected substrate.

16. The apparatus of claim 13, wherein said portion of said interstitial space is filled with said filler material by a process comprising at least one of chemical vapor deposition, physical vapor deposition, plasma deposition, ion sputtering, electrochemical deposition and casting from a liquid phase.

17. The apparatus of claim 13, wherein said exposed second ends of said at least first and second CNTs are provided by a process comprising at least one of mechanical polishing, chemical-mechanical polishing, wet chemical etching, electrochemical etching and dry plasma etching.

18. The apparatus of claim 13, wherein said exposed ends of said first and second CNTs in said array have an exposed first length and an exposed second length, respectively, that

are not covered by said filler material, where the exposed first length and the exposed second length are substantially equal.

19. The apparatus of claim 13, wherein said exposed ends of said first and second CNTs in said array have an exposed first length and an exposed second length, respectively, that are not covered by said filler material, where the exposed first length is greater than the exposed second length.

20. The apparatus of claim 3, wherein said transport of said thermal energy from said object occurs with an associated thermal resistance of no more than about $8 \text{ cm}^2\text{-K/Watt}$.

21. The apparatus of claim 13, wherein said transport of said thermal energy from said object occurs with an associated thermal resistance of no more than about $0.1 \text{ cm}^2\text{-K/Watt}$.

22. The apparatus of claim 13, wherein said thermal energy is removed from said object initially through said exposed second ends of said at least first and second CNTs in contact with said object, and subsequently through said filler material that makes contact with said at least first and second CNTs.

23. The apparatus of claim 13, wherein said thermal energy is removed from said object contemporaneously through said exposed second ends of said at least first and second CNTs in contact with said object and through said filler material that makes contact with said at least first and second CNTs.

24. The apparatus of claim 13, wherein said object has a surface for said contact that is rough on an atomic scale and is not substantially planar.

25. An apparatus for providing for transport of thermal energy from an object, the apparatus comprising:

an array of carbon nanotubes or carbon nanofibers, referred to herein as "CNTs," on a surface of a substrate, wherein at least first and second CNTs in the array are oriented substantially perpendicular to the surface of the substrate; and

a filler material that fills at least a portion of an interstitial space between the at least first and second CNTs in the array;

wherein:

the filler material makes contact with the surface of the substrate at a first end of each of the at least first and second CNTs;

a second end of each of the at least first and second CNTs is exposed and is not fully covered by the filler material;

the exposed second ends of the at least first and second CNTs are configured to make contact with a surface of an object for which transport of thermal energy is to be provided so that at least one of the exposed second ends of the CNTs bends or buckles; and

the thermal resistance of the apparatus is no more than about $0.9 \text{ cm}^2\text{K/W}$.

26. An apparatus for providing for transport of thermal energy from an object, the apparatus comprising:

an array of carbon nanotubes or carbon nanofibers, referred to herein as "CNTs," on a surface of a substrate, wherein at least first and second CNTs in the array are oriented substantially perpendicular to the surface of the substrate; and

a filler material that fills at least a portion of an interstitial space between the at least first and second CNTs in the array;

wherein:

11

the filler material makes contact with the surface of the substrate at a first end of each of the at least first and second CNTs;

the at least first and second CNTs each have a respective second end that is different from each respective first end;

the respective second ends of the at least first and second CNTs are configured to make contact with a surface of an object for which transport of thermal energy is to be provided so that at least one of the respective second ends of the CNTs bends or buckles; and

the thermal resistance of the apparatus is no more than about 0.9 cm²K/W.

27. The apparatus of claim 26, wherein the apparatus is configured to make contact with the surface of the object with a contact pressure of no more than 20 psi.

28. The apparatus of claim 26, wherein the thermal resistance of the apparatus is no more than about 0.1 cm²K/W.

29. A method for making an apparatus for transporting thermal energy from an object, the method comprising:

providing an array of carbon nanotubes or carbon nanofibers, referred to herein as "CNTs," on a surface of a substrate, wherein at least first and second CNTs in the array are oriented substantially perpendicular to the surface of the substrate; and

after providing the array of CNTs, filling at least a portion of an interstitial space between the at least first and second CNTs in the array with a filler material;

wherein:
the filler material makes contact with the surface of the substrate at a first end of each of the at least first and second CNTs;

the at least first and second CNTs each have a respective second end that is different from each respective first end;

12

the respective second ends of the at least first and second CNTs are configured to make contact with a surface of an object for which transport of thermal energy is to be provided so that at least one of the respective second ends of the CNTs bends or buckles; and

the thermal resistance of the apparatus is no more than about 0.9 cm²K/W.

30. A method for transporting thermal energy from an object, the method comprising:

contacting an object with an apparatus comprising an array of carbon nanotubes or carbon nanofibers, referred to herein as "CNTs," and a filler material that fills at least a portion of an interstitial space between at least first and second CNTs in the array, wherein:

the filler material makes contact with a surface of a substrate at a first end of each of the at least first and second CNTs;

the at least first and second CNTs in the array are oriented substantially perpendicular to the surface of the substrate;

the at least first and second CNTs each have a respective second end that is different from each respective first end;

the respective second ends of the at least first and second CNTs make contact with a surface of the object so that at least one of the respective second ends of the CNTs bends or buckles; and

the thermal resistance of the apparatus is no more than about 0.9 cm²K/W; and

transporting thermal energy from the object with the array of CNTs and the filler material.

* * * * *