

High Pressure Composite Overwrapped Pressure Vessel (COPV) Development Tests at Cryogenic Temperatures

David M. Ray, P.E.¹

NASA Johnson Space Center, Houston, TX, USA

Nathanael J. Greene²

NASA White Sands Test Facility, Las Cruces, NM, USA

Duane Revilock³

NASA Glenn Research Center, Cleveland, OH, USA

Kirk Sneddon⁴

ARDE', Inc., Norwood, NJ, USA

and

Estelle Anselmo⁵

ARDE', Inc., Norwood, NJ, USA

49th AIAA/ASME/ASCE/AHS/ASC Structures, Structural Dynamics, and Materials Conference, Schaumburg, IL, April 7-10, 2008

Nomenclature

| | | |
|----------------------|---|---|
| <i>APS</i> | = | Advanced Propulsion System |
| <i>COPV</i> | = | Composite Overwrapped Pressure Vessel |
| <i>D</i> | = | diameter |
| <i>DIC</i> | = | Digital Imaging Correlation |
| <i>GHe</i> | = | Gaseous Helium |
| <i>lbm</i> | = | pounds in mass |
| <i>LCH4</i> | = | Liquid Methane |
| <i>LN2</i> | = | Liquid Nitrogen |
| <i>LO2</i> | = | Liquid Oxygen |
| <i>LSAM</i> | = | Lunar Surface Access Module |
| <i>LM</i> | = | Lunar Module |
| <i>MOP</i> | = | Maximum Operating Pressure |
| <i>P_b</i> | = | Burst Pressure |
| <i>PCAD</i> | = | Propulsion and Cryogenic Advanced Development |
| <i>PER</i> | = | Performance Efficiency Rating |
| <i>psi</i> | = | pounds per square inch |
| <i>psig</i> | = | pounds per square inch gage |
| <i>RCS</i> | = | Reaction Control System |
| <i>ρ</i> | = | Density |
| <i>σ_t</i> | = | Tensile Strength |
| <i>t</i> | = | Thickness |
| <i>V</i> | = | Volume |
| <i>W</i> | = | Weight |

¹ Project Engineer, NASA JSC

² Test Engineer, NASA WSTF

³ Test Engineer, NASA GRC

⁴ President, ARDE', Inc.

⁵ Chief Engineer, ARDE', Inc.

Abstract

Development tests were conducted to evaluate the performance of 2 COPV designs at cryogenic temperatures. This allows for risk reductions for critical components for a Gaseous Helium (GHe) Pressurization Subsystem for an Advanced Propulsion System (APS) which is being proposed for NASA's Constellation project and future exploration missions. It is considered an advanced system since it uses Liquid Methane (LCH₄) as the fuel and Liquid Oxygen (LO₂) as the oxidizer for the propellant combination mixture. To avoid heating of the propellants to prevent boil-off, the GHe will be stored at subcooled temperatures equivalent to the LO₂ temperature. Another advantage of storing GHe at cryogenic temperatures is that more mass of the pressurized GHe can be charged in to a vessel with a smaller volume, hence a smaller COPV, and this creates a significant weight savings versus gases at ambient temperatures. The major challenge of this test plan is to verify that a COPV can safely be used for spacecraft applications to store GHe at a Maximum Operating Pressure (MOP) of 4,500 psig at 140R to 160R (-320°F to -300°F). The COPVs for these tests were provided by ARDE', Inc. who developed a resin system to use at cryogenic conditions and has the capabilities to perform high pressure testing with LN₂.

I. Introduction

NASA Johnson Space Center in Houston, Texas has been performing design, development and testing for cryogenic propulsion systems under the term PCAD (Propulsion and Cryogenic Advanced Development). The major effort in cryogenic propulsion system development for future exploration missions includes the use of propellants such as LO₂, LH₂ and LCH₄ which can be produced from resources available on the surface of the moon and Mars. A schematic of a cryogenic propulsion system using LO₂ and LCH₄ is shown in Figure 1. This system is being proposed for the Constellation project which will take a Lunar Surface Access Module (LSAM), which is called the 'Altair' to the moon. Altair, which is similar in design, but much larger than the Apollo Lunar Module (LM), will consist of two stages: 1) a descent stage, which will house the majority of the fuel, power supplies, and breathing oxygen for the crew, and 2) an ascent stage, which will house the astronauts, life-support equipment, and fuel for the ascent stage motor and steering rockets.¹ A picture of the Altair aboard the Ares V launch vehicle is shown in Figure 2. The schematic in Figure 1 represents the Ascent Engines for Altair. The Ascent Engines are used in the mission profile to dock with Orion which is a Crew Module and a Service Module that is launched on the Ares I launch vehicle. Figure 3 shows a description of the mission profile using the Ares I and Ares V launch vehicles.

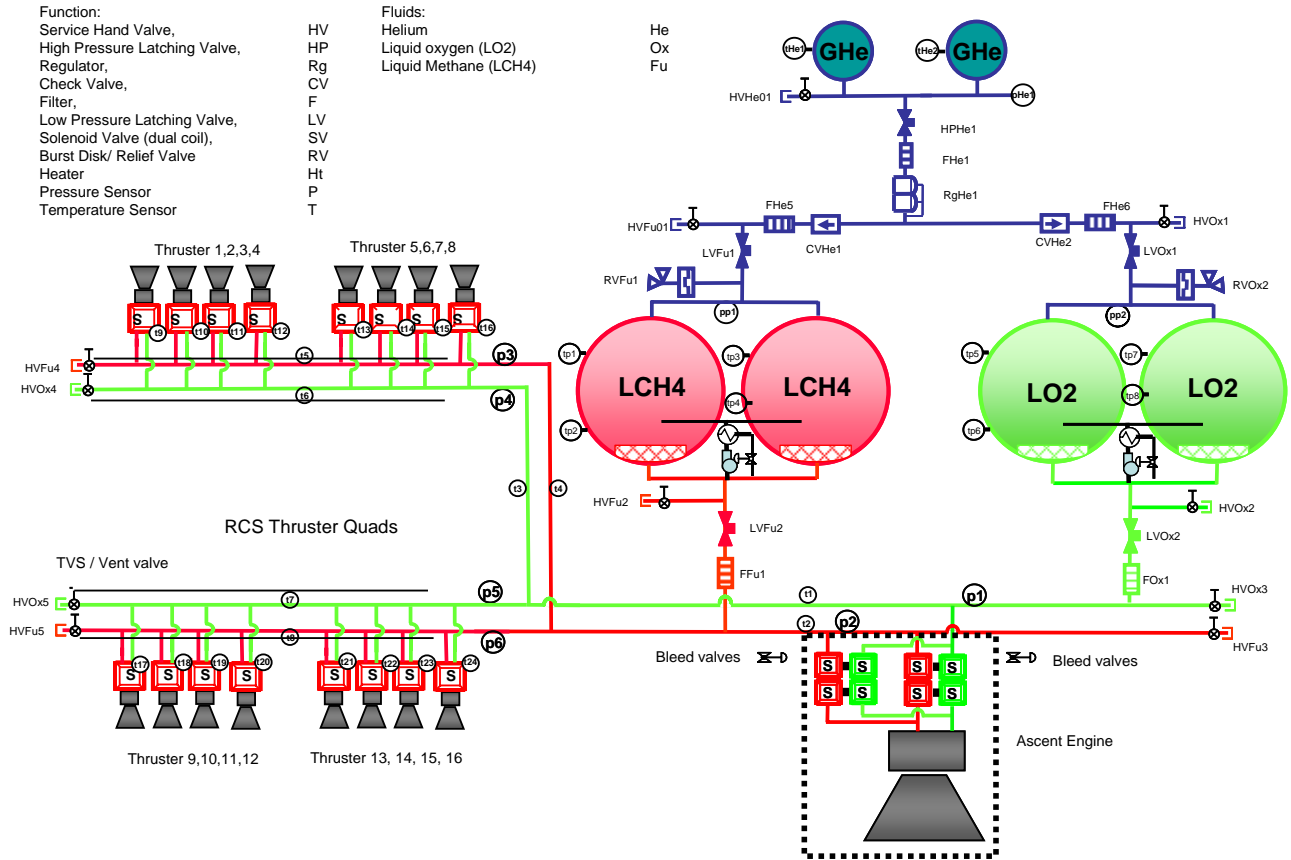

Figure 1. LO2 and LCH4 Propulsion System Schematic

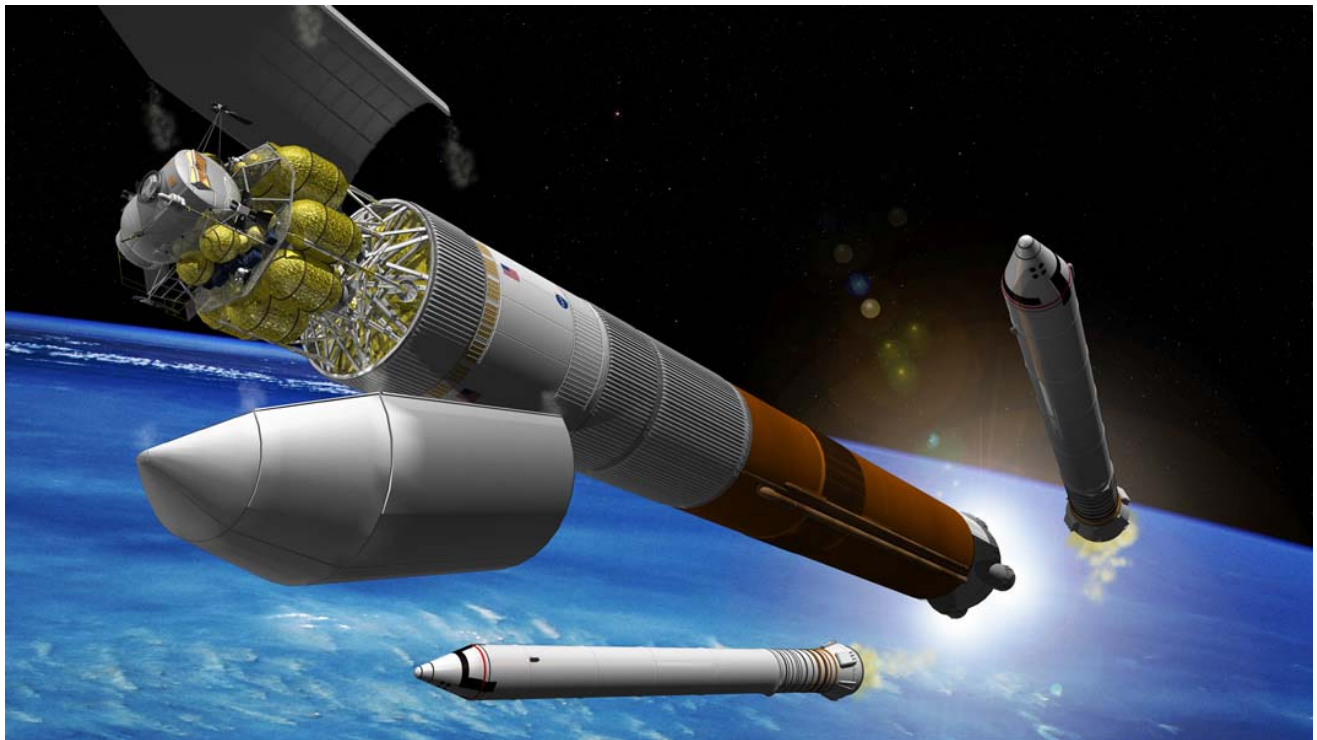

Figure 2. LSAM on the Ares V Launch Vehicle

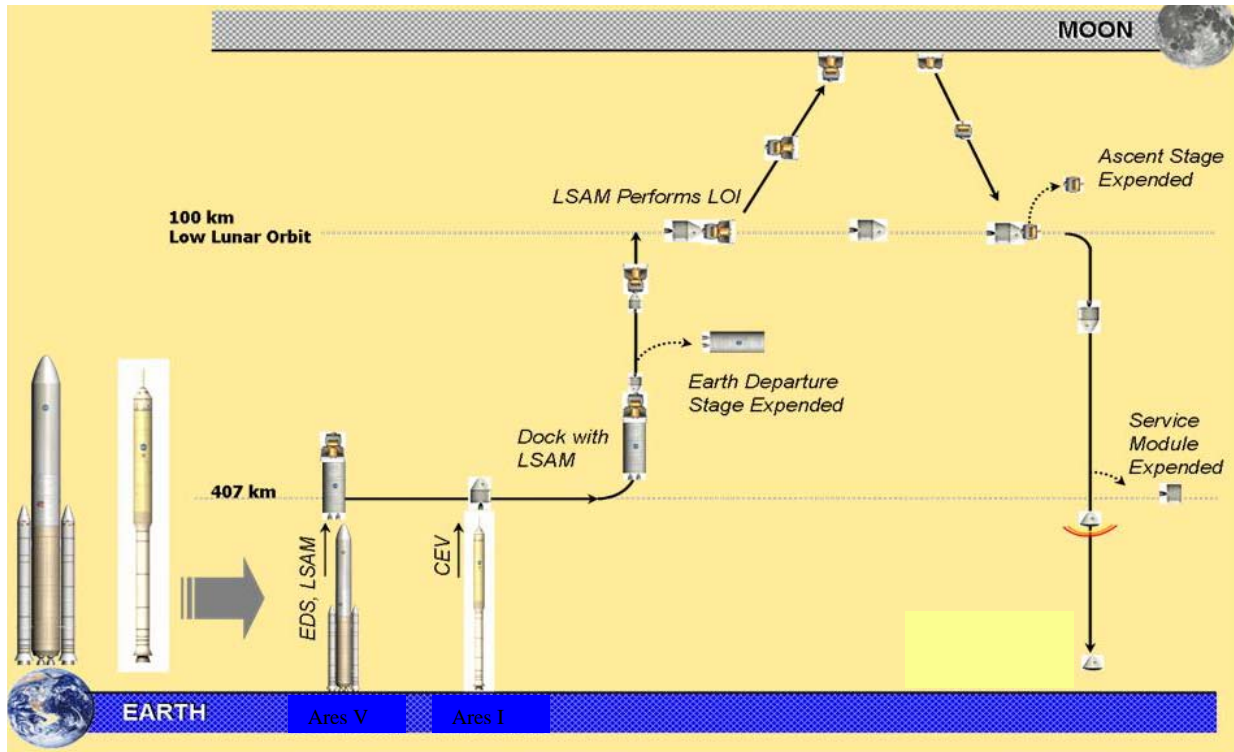

Figure 3. Constellation Mission Profile

In Figure 1, the propellants are fed to the RCS thrusters and the Ascent Engine in a liquid state using the GHe pressurization subsystem. Can the GHe COPVs be cycled at cryogenic conditions and perform similar to cycling at ambient conditions to meet the performance requirements? This is the primary concern and the driver for the test plan that was created and executed.

II. Test Article Description

The test articles will consist of vessels lined with Inconel 718 and Al-2219. Inconel 718 has been selected since it is LO₂ compatible and it provides excellent corrosion resistance and provides good material fracture toughness at cryogenic temperatures.² Al-2219 has been selected since it is lighter in weight and it can be used if the risk of exposure to LOX is acceptable based on the propulsion system design. The volume of the vessels for these tests is 1.8 ft³ and it will be a sphere with an inner diameter of approximately 18.12 in. The flight article design concept calls for a 20 ft³ spherical vessel. A scaled down vessel has been selected for these tests since current tooling and fabrication procedures exist for a 1.8 ft³ vessel and this provides lower costs and quicker delivery. Another major objective of these initial tests is to determine if the fiber/resin composite provides successful performance at cryogenic temperatures. Table 1 shows the information for the test articles for the tests where proof pressure for the vessels is 1.25 X MOP and the minimum burst pressure is 1.5 X MOP.

Table 1. Test Articles

| Part No. | Liner | Resin | Fiber | MOP (psig) | Proof Pressure (psig) | Min. Burst Pressure (psig) | Operating Temperature |
|----------|-------------|--------|----------------|------------|-----------------------|----------------------------|-----------------------|
| D4970 | Inconel 718 | 31-43B | Torayca T-1000 | 4500 | 5625 | 6750 | -320 °F |
| D4971 | Al 2219-T62 | 31-43B | Torayca T-1000 | 4500 | 5625 | 6750 | -320 °F |

The 31-43B resin has been selected based on previous research and development work performed by ARDE', Inc. The Toray T-1000 carbon fiber by Torayca has been selected since NASA plans to use it for the fabrication of the flight vessels. The Toray fiber is provided on a spool. The spool provides a 'tow' which is a bundle of 12,000 fibers. The cross-sectional area of a tow is approximately 0.000417 inch². Table 2 shows the properties for Toray T-1000.³

Table 2. Properties of Toray T-1000

| Fiber | Tensile Strength σ_t (psi) | Density ρ (lb/in ³) | Tensile Modulus (psi) |
|--------|-----------------------------------|--------------------------------------|-----------------------|
| T-1000 | 924,000 | 0.0654 | 42,700,000 |

A spherical liner has been chosen for the design concept instead of a cylinder liner since spheres provide better performance for low blow-down pressures at cryogenic temperatures and it has a lower volume to surface area ratio which minimizes the amount of heat transfer. A picture of Part No. D4970 is shown in Figure 4.



Figure 4. Picture of Arde' Part no. D4970

A non-bonded interface between the liner and the overwrap exists for preventing buckling of the liner for thermal cycle tests. The liner and the resin/fiber overwrap have much different coefficients of thermal expansion. This causes buckling of the liner for bonded interfaces at temperature cycles from ambient to cryogenic conditions since the metal liner expands and contracts significantly more than the overwrap. ARDE' applies a non-stick coating to the liner prior to wrapping procedures that results in a non-bonded liner/overwrap interface after proof tests are complete.

III. Test Procedures

There will be a quantity of 5 each of test article D4970 and D4971 to provide performance data at ambient and cryogenic conditions. An extensive data base exists for ambient temperature testing on ARDE's D4333 vessel which has a CRES 301 liner and is a 1.8 ft³ spherical COPV. The design of the D4970 and D4971 vessels is based on the D4333 vessel where the liner material has been changed. Of the 5 test articles, 2 articles will go through ambient tests and 3 will go through cryogenic tests. The objective is to determine if there are significant differences in the performance of the vessels at ambient conditions versus cryogenic conditions and the difference between Inconel 718 and Al-2219.

Following are the test procedures to be performed on the series of test articles.

Ambient

1. Perform 2 proof pressure tests hydrostatically to 1.25 X MOP = 5625 psig.
2. Perform 100 pressure cycles from 0 to 4,500 psig with water.
3. Perform hydrostatic burst pressure tests using Digital Imaging Correlation (DIC) equipment to measure the strain as the pressure is increased to the rupture event.

Cryogenic

1. Perform 2 proof pressure tests to 1.25 X MOP = 5625 psig at -320°F where LN2 is in the COPV and GN2 is the pressurant.
2. Perform thermal cycle testing 5 times where the COPV is filled with and submerged in LN2 with no applied pressure.
3. Perform 100 pressure cycles charging to 4,500 psig at -320°F using LN2 where GN2 is the pressurant while the COPV is submerged in LN2.
4. Perform burst pressure tests with LN2 at -320°F.

IV. Test Results

Table 2 shows the performance of the Inconel 718 COPVs and Table 3 shows the results of the Al-2219 COPVs. Figure 5 shows a graph of all the results for comparisons of the performance at ambient and cryogenic conditions for Inconel 718 versus Al-2219.

Table 2. Inconel 718 Lined COPV Results – ARDE’, Inc. Part No. D4970

| Vessel Serial No. | Burst Pressure P _b (psig) | Temp. | Volume V (in ³) | Weight W (lbm) | Performance Efficiency Rating PER = P _b V/W | MOP (psig) | Actual Burst Factor |
|-------------------|--------------------------------------|---------|-----------------------------|----------------|---|------------|---------------------|
| 001 | 10,670 | Cryo | 3141 | 25.45 | 1,316,875 | 4,500 | 2.37 |
| 002 | 11,140 | Cryo | 3141 | 25.45 | 1,374,882 | 4,500 | 2.48 |
| 003 | 10,620 | Cryo | 3141 | 25.45 | 1,310,704 | 4,500 | 2.36 |
| 004 | ** | Cryo | 3141 | 25.45 | N/A | 4,500 | N/A |
| 005 | 11,140 | Ambient | 3141 | 25.45 | 1,374,882 | 4,500 | 2.48 |
| 006 | 10,910 | Ambient | 3141 | 25.45 | 1,346,495 | 4,500 | 2.42 |

** S/N 004 was subjected to cryo proof cycle and thermal cycles and shipped to NASA/JSC for further testing.

Table 3. Al 2219 Lined COPV Results – ARDE’, Inc. Part No. D4971

| Vessel Serial No. | Burst Pressure P_b (psig) | Temp. | Volume V (in ³) | Weight W (lbm) | Performance Efficiency Rating PER = $P_b V/W$ | MOP (psig) | Actual Burst Factor |
|-------------------|-----------------------------|---------|-----------------------------|----------------|--|------------|---------------------|
| 003 | 13,000 | Ambient | 3141 | 23.1 | 1,767,662 | 4,500 | 2.89 |
| 004 | 13,010 | Ambient | 3141 | 23.1 | 1,769,022 | 4,500 | 2.89 |
| 005 | 12,300 | Cryo | 3141 | 23.1 | 1,672,481 | 4,500 | 2.73 |
| 006 | 12,000 | Cryo | 3141 | 23.1 | 1,631,688 | 4,500 | 2.67 |
| 007 | 11,500 | Cryo | 3141 | 23.1 | 1,563,701 | 4,500 | 2.56 |
| 008 | ** | Cryo | 3141 | 23.1 | N/A | 4,500 | N/A |

** S/N 008 was subjected to cryo proof cycle and thermal cycles and shipped to NASA/JSC for further testing.

Burst Test Results

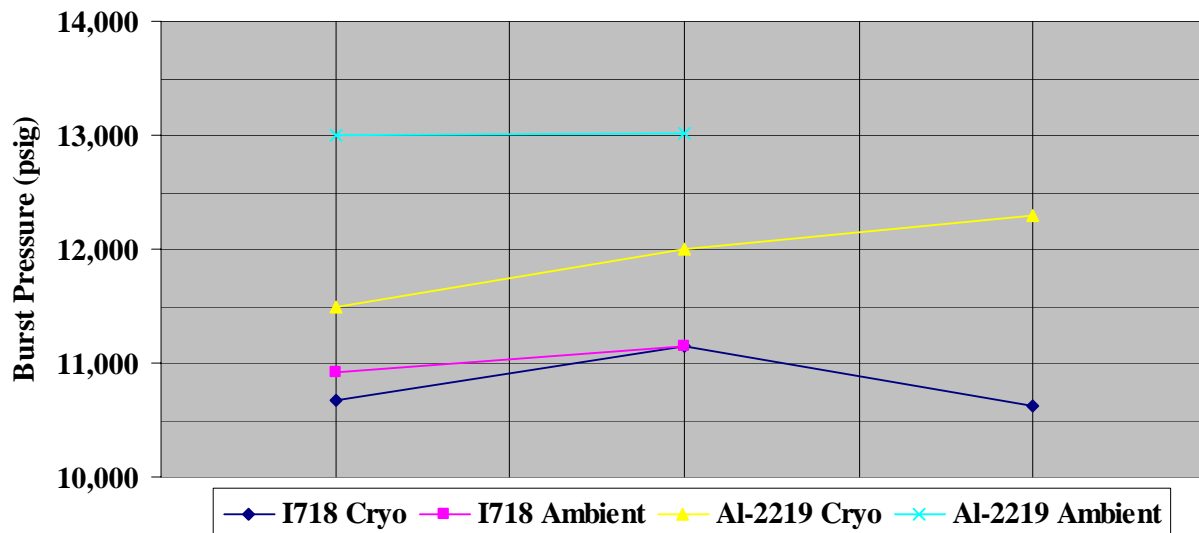

Figure 5. Burst Test Results for All Vessels

These results for the burst tests for both Inconel 718 and Al-2219 show that the minimum burst pressure was met where the smallest burst pressure is 2.36 X MOP or 10,620 psig for the cryogenic burst tests of Inconel 718. Comparisons of the Al-2219 versus the Inconel 718 show that the Al-2219 provided higher burst pressures at a lower vessel weight than the Inconel 718. The Al-2219 vessels have more overwrap due to the reduced tensile strength of Al-2219 but the results show that Al-2219 can provide the required burst pressures after proof tests, pressure cycles and thermal cycles.

The area where the vessels failed is in the welded region in the liner between the precision machined boss section and the dome. This was consistent in all of the burst tests. This is expected since the machined boss sections are thicker than the formed domes. Figure 6 shows the burst test results for an Inconel 718 lined vessel at ambient conditions and Figure 7 shows the burst test results for an Inconel 718 lined vessel at cryogenic conditions. Figure 8 shows the burst test results for an Al-2219 lined vessel at ambient conditions and Figure 9 shows the burst test results for on Al-2219 lined vessel at cryogenic conditions.



Figure 6. Ambient Burst Test for Part No. D4970, S/N 006



Figure 7. Cryogenic Burst Test for Part No. D4970, S/N 002



Figure 8. Ambient Burst Test for Part No. D4971, S/N 003



Figure 9. Cryogenic Burst Test Vessel Part No. D4971, S/N 005

V. Conclusion

Inconel 718 is a very tough and fracture resistant material even at cryogenic conditions and performed very well based on the cryogenic burst tests vs. the ambient burst tests.

Al-2219 also performed very well and it was wrapped with more fiber due to its lower mechanical properties compared to Inconel 718 but still had a lower weight. This test provided the data required for NASA to develop high pressure vessels for the future exploration missions. Al-2219 can be used as liner material where it saves weight and still performs well at cryogenic conditions. The remaining risk for COPVs that needs to be tested regards stress rupture life at cryogenic conditions. Current plans are to continue to use small scale COPVs and charge them with LN2 at higher fiber stress ratios for certain time durations to determine the proper stress rupture life prediction models to use.

Acknowledgments

Thanks to Kris Romig of NASA Johnson Space Center for providing the funding to support these tests. Sincere thanks and appreciations to the engineers and technicians at ARDE', Inc. for the quality and expertise in the fabrication and testing of COPVs with LN2. Thanks to the folks at Composites Atlantic Limited in Lunenburg, Nova Scotia for showing David Ray and Nathanael Greene the wrapping and fiber test operations during the wrapping of the Inconel 718 lined COPVs. Thanks to Duane Revilock of NASA Glenn Research Center for the strain data that was collected with Digital Imaging Correlation equipment.

References

- ¹NASA Constellation Program, http://www.nasa.gov/mission_pages/constellation/ares/index.html
- ²Baumeister, T., and Marks, L. S., *Standard Handbook for Mechanical Engineers*, 7th ed., McGraw-Hill, New York, 1967, pp. 6-82.
- ³Torayca T1000G Technical Data Sheet, No. CFA-008, Toray Carbon Fibers America, Inc., Santa Ana, CA.