



US007173749B2

(12) **United States Patent**
Maleki et al.

(10) **Patent No.:** US 7,173,749 B2

(45) **Date of Patent:** Feb. 6, 2007

(54) **OPTO-ELECTRONIC FEEDBACK FOR STABILIZING OSCILLATORS**

(75) Inventors: **Lutfollah Maleki**, Pasadena, CA (US);
Vladimir Ilchenko, Arcadia, CA (US)

(73) Assignee: **California Institute of Technology**,
Pasadena, CA (US)

(*) Notice: Subject to any disclaimer, the term of this patent is extended or adjusted under 35 U.S.C. 154(b) by 341 days.

(21) Appl. No.: **10/911,401**

(22) Filed: **Aug. 4, 2004**

(65) **Prior Publication Data**

US 2005/0063034 A1 Mar. 24, 2005

Related U.S. Application Data

(60) Provisional application No. 60/492,572, filed on Aug. 4, 2003.

(51) **Int. Cl.**

G02F 1/01 (2006.01)

G02F 1/00 (2006.01)

G02F 1/03 (2006.01)

H01S 3/10 (2006.01)

G01N 27/00 (2006.01)

(52) **U.S. Cl.** **359/239**; 359/237; 359/245;
359/279; 359/334; 372/20; 372/29.011; 372/94;
372/108; 331/1 R; 331/16; 331/66; 250/205;
250/227.11; 385/39; 385/50; 398/39

(58) **Field of Classification Search** 359/237,
359/239, 245, 279, 334; 372/9, 20, 29.011,
372/32, 50.1, 50.21, 94, 98, 104, 108; 331/1 R,
331/16, 25, 66, 172; 250/205, 227.11; 385/37,
385/39, 50; 398/39, 161
See application file for complete search history.

(56) **References Cited**

U.S. PATENT DOCUMENTS

5,204,640 A 4/1993 Logan, Jr. 331/9
5,220,292 A 6/1993 Bianchini et al. 331/1 R

(Continued)

FOREIGN PATENT DOCUMENTS

WO WO0196936 12/2001

OTHER PUBLICATIONS

Logan et al.; Stabilization of Oscillator Phase Using a Fiber-Optic Delay-Line; 1991; 45th Annual Symposium on Frequency Control; pp. 508-512.

(Continued)

Primary Examiner—Loha Ben

(74) *Attorney, Agent, or Firm*—Fish & Richardson P.C.

(57) **ABSTRACT**

This application describes use of an opto-electronic feedback in oscillators to suppress phase noise based on the high Q factor of the opto-electronic feedback.

27 Claims, 4 Drawing Sheets

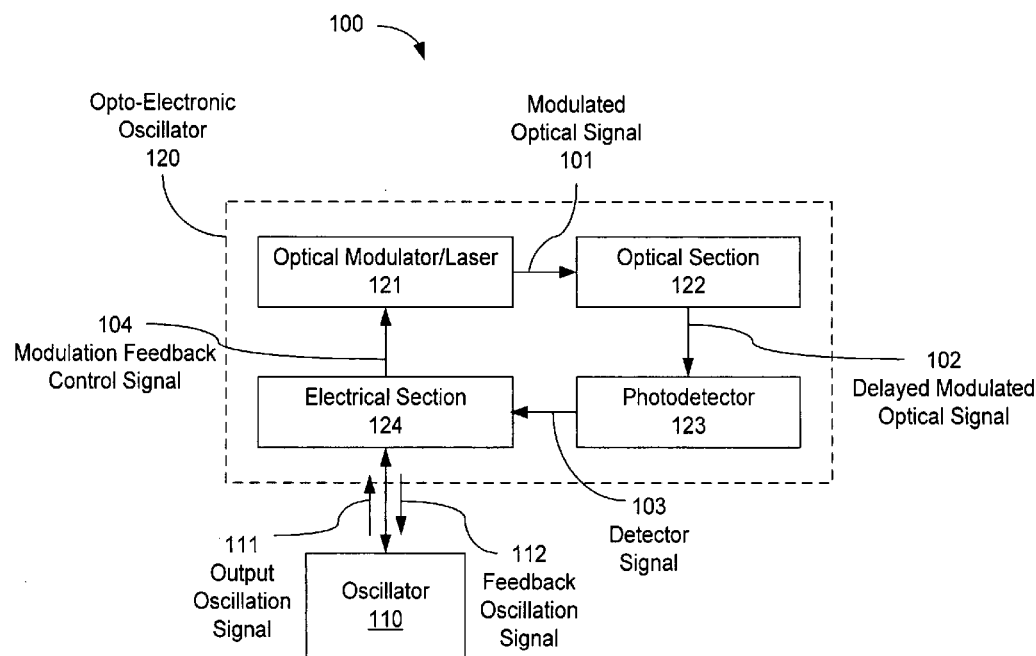

U.S. PATENT DOCUMENTS

5,723,856 A	3/1998	Yao et al.	250/227.11
5,777,778 A	7/1998	Yao	359/245
5,917,179 A	6/1999	Yao	250/227.11
5,929,430 A	7/1999	Yao et al.	250/205
6,138,076 A	10/2000	Graf et al.	702/14
6,389,197 B1	5/2002	Iltchenko et al.	385/28
6,417,957 B1	7/2002	Yao	359/334
6,473,218 B1	10/2002	Maleki et al.	359/245
6,476,959 B2	11/2002	Yao	359/334
6,487,233 B2	11/2002	Maleki et al.	372/108
6,488,861 B2	12/2002	Iltchenko et al.	216/24
6,490,039 B2	12/2002	Maleki et al.	356/436
6,535,328 B2	3/2003	Yao	359/334
6,567,436 B1	5/2003	Yao et al.	372/32
6,580,532 B1	6/2003	Yao et al.	398/39
6,594,061 B2	7/2003	Huang et al.	359/239
6,762,869 B2	7/2004	Maleki et al.	359/239

6,928,091 B1 *	8/2005	Maleki et al.	372/20
2002/0018611 A1	2/2002	Maleki et al.	385/15
2003/0012504 A1	1/2003	Iltchenko	385/39

OTHER PUBLICATIONS

L.E. Myers, et al.; Quasi-phase-matched optical parametric oscillators in bulk periodically poled LiNbO₃; Nov. 1995; J.Opt. Soc. Am. B/vol. 12, No. 11; pp. 2102-2116.

X. Steve Yao, et al.; Converting Light into Spectrally Pure Microwave Oscillation; Apr. 1996; Optics Letters, vol. 21, No. 7; pp. 483-485.

H. Ito, et al.; InP/InGaAs uni-travelling-carrier photodiode with 310 GHz receiver; Oct. 12, 2000; Electronics Letters, vol. 36, No. 21; pp. 1809-1810.

V. Iltchenko, et al.; Sub-Micro Watt Photonic Microwave Receiver; Nov. 2002; IEEE Photonics Technology Letters, vol. 14, No. 11; pp. 1602-1604.

* cited by examiner

FIG. 1

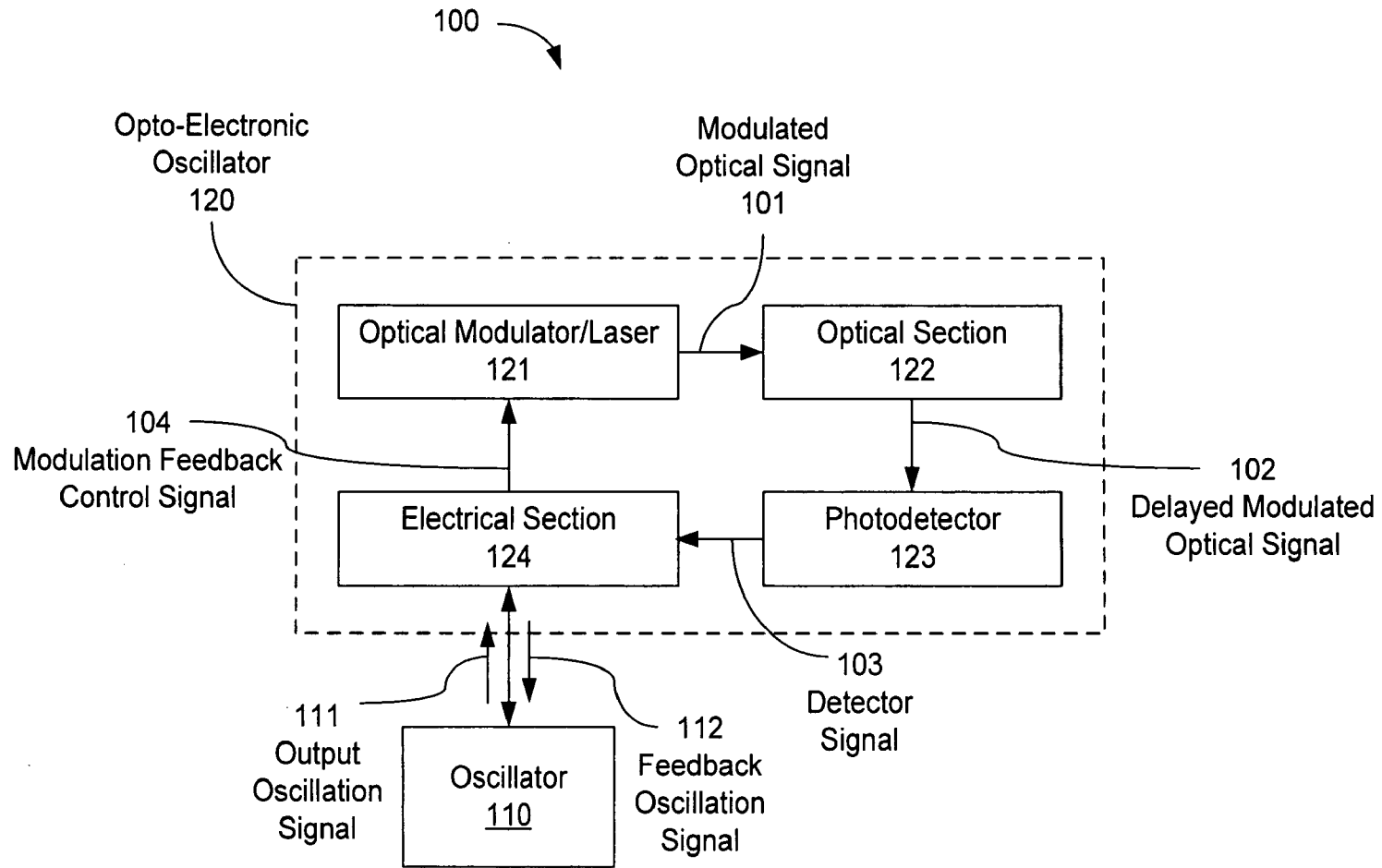

FIG. 2

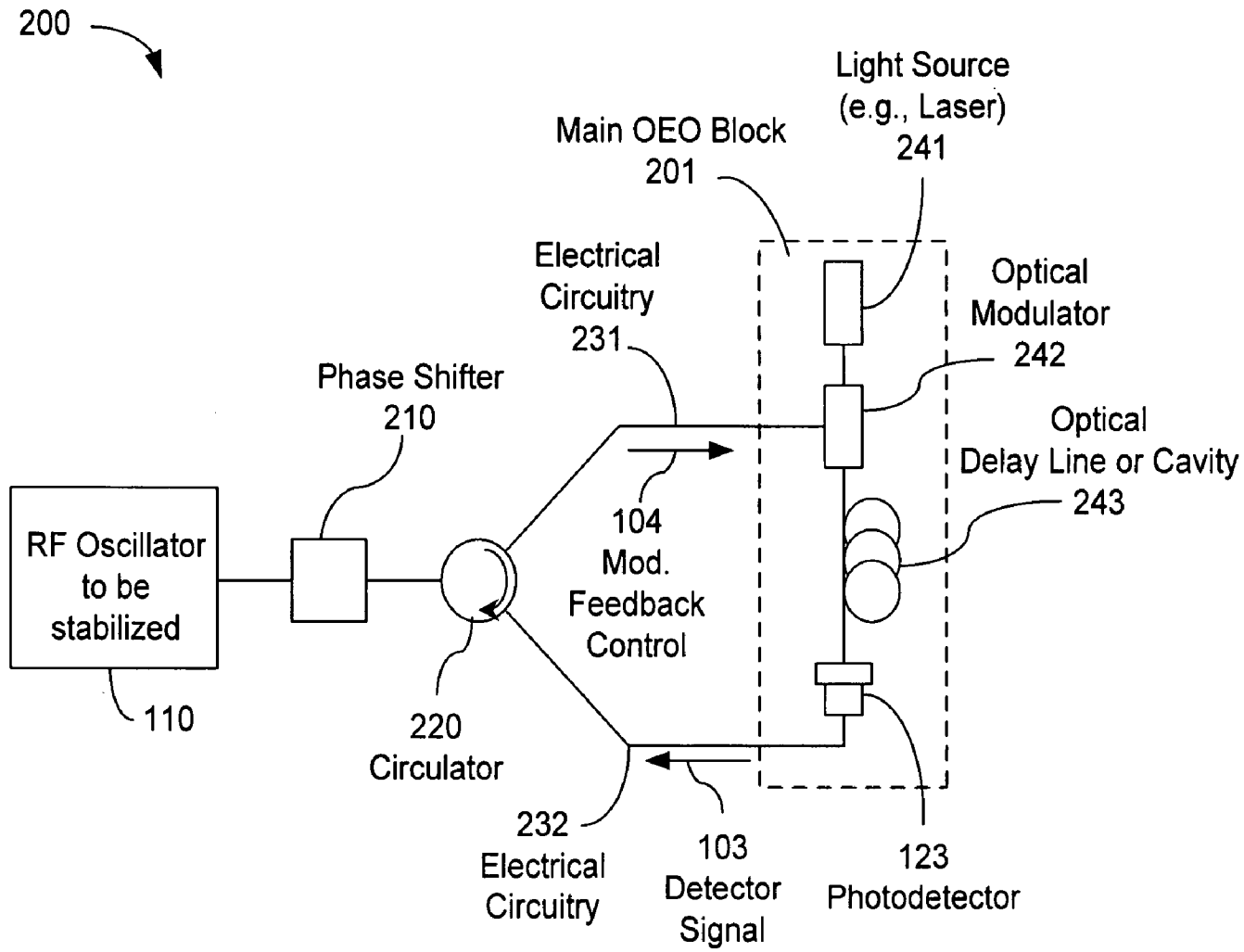

FIG. 3

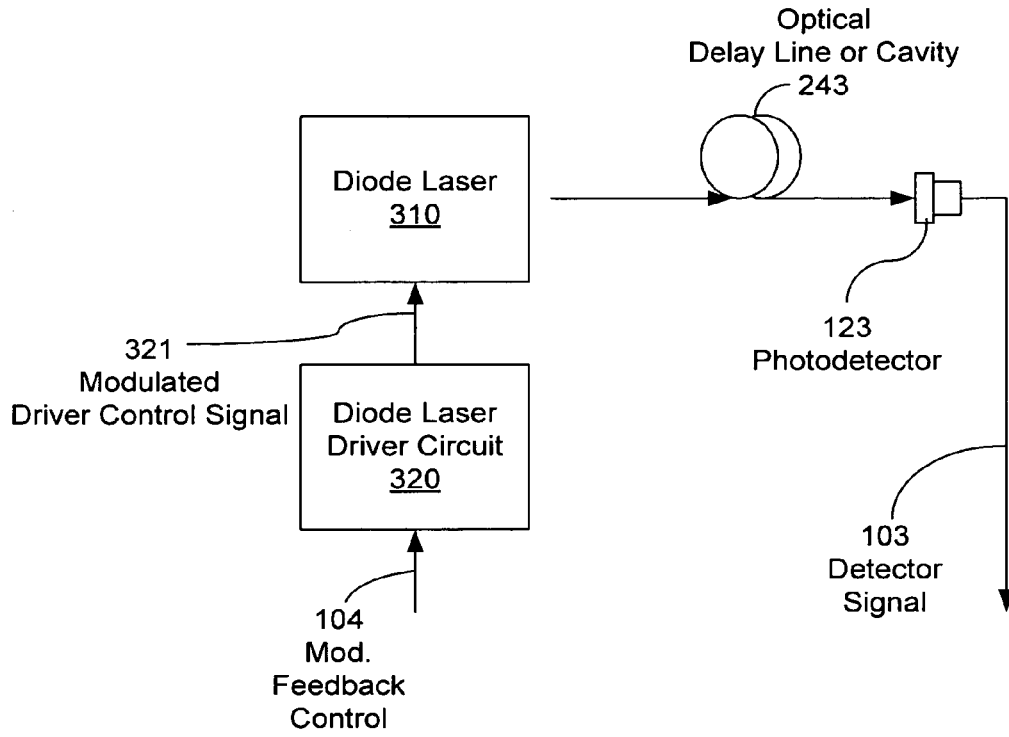

FIG. 4

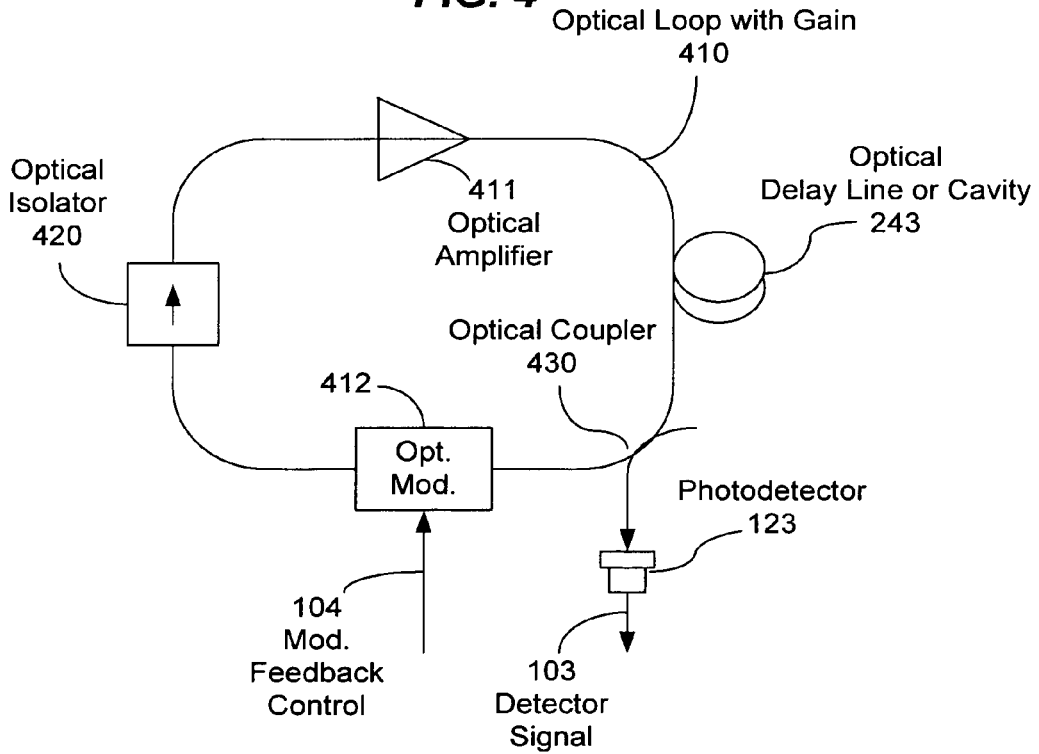

FIG. 5

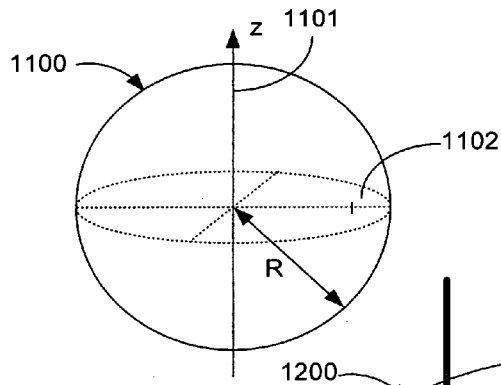

FIG. 6

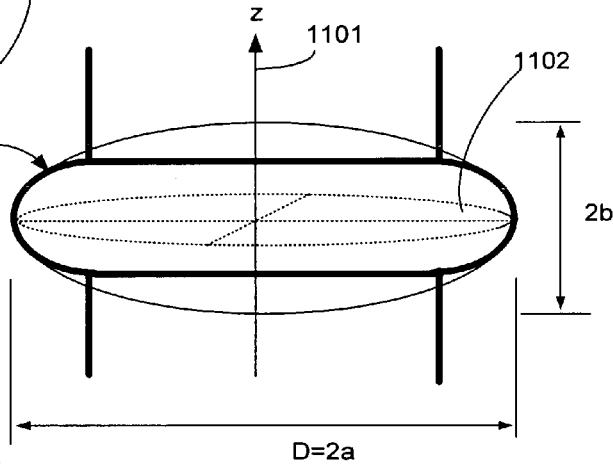

FIG. 7

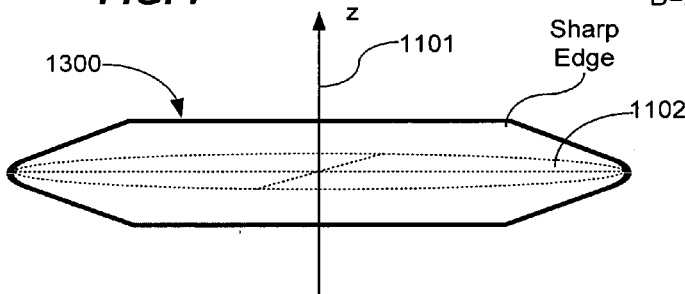

FIG. 8A

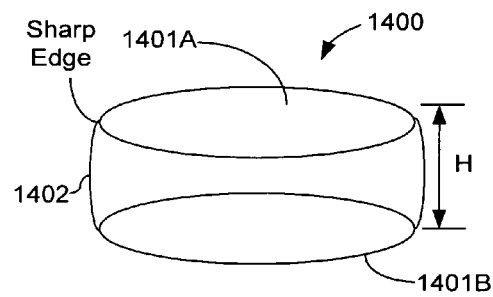
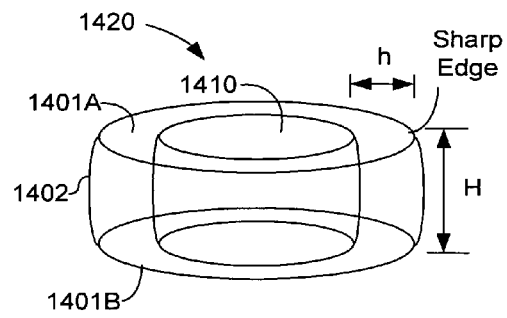

FIG. 8B



OPTO-ELECTRONIC FEEDBACK FOR STABILIZING OSCILLATORS

This application claims the benefit of U.S. Provisional Patent Application No. 60/492,572 entitled "Simple opto-electric feedback in microwave and millimeter-wave oscillators" and filed Aug. 4, 2003, the entire disclosure of which is incorporated herein by reference as part of the specification of this application.

The research and development for inventions described in this application received funding under Grant No. NAS7-1407 from NASA. The U.S. Government may have rights to various technical features described in this application.

BACKGROUND

This application relates to RF, microwave, and millimeter-wave oscillators.

Signal oscillators operating oscillating frequencies in the RF, microwave, and millimeter frequencies are widely used for in various applications. As an example, such oscillation signals at these frequencies may be used for generating, tracking, cleaning, amplifying, and distributing RF carriers. Such an oscillator may exhibit phase noise and cause the oscillating frequency to drift or fluctuate. This phase noise is undesirable and may adversely affect device performance in devices using such an oscillator.

One way to mitigate this phase noise in signal oscillators is to provide a negative feedback control loop where the feedback signal is out of phase with the oscillator signal in order to stabilize the oscillator. For example, a voltage-controlled oscillator (VCO) may be designed to use voltage controlled phase-locked loop to control the oscillator frequency by minimizing the difference between the current phase values of the oscillator signal and of another relatively delayed oscillation signal. A typical VCO is a two-port device and the phase-locked loop is connected between the two ports. VCOs may be used for, among others, clock recovery, carrier recovery, signal modulation and demodulation, and frequency synthesizing.

A negative opto-electronic feedback loop may be used as the phase-locked loop in a VCO. U.S. Pat. No. 5,204,640 to Logan describes tunable voltage controlled two-port oscillators that use feedback loops with a fiber optic delay line to provide a long delay of, e.g., one millisecond or more, in stabilizing the oscillators. Such a feedback loop is an opto-electronic loop because part of the loop is the fiber optic delay line and part of the loop is electronic circuitry. A photodetector is used to convert the optical signal in the fiber optic delay line into an electronic signal in the electronic circuitry. Also, see Logan et al. in "Stabilization of Oscillator Phase Using a Fiber-Optic Delay-Line" on pages 508-512 in 45th Annual Symposium On Frequency Control (1991).

SUMMARY

This application describes oscillators with a feedback control that is derived from a positive, oscillating opto-electronic closed loop of a separate opto-electronic oscillator. In one implementation, for example, a device described in this application includes an oscillator producing an electrical oscillation signal, and an opto-electronic oscillator coupled to the oscillator. The opto-electronic oscillator includes a positive feedback loop which comprises an optical section, an electrical section, and an optical detector to connect the optical section and the electrical section. The

optical section comprises an optical modulator modulating light under control of an electrical output signal from the electrical section and an optical delay line to receive an optical output of the optical modulator. The electrical section of the positive feedback loop is coupled to receive the electrical oscillation signal from the oscillator and to send an electrical signal in the electrical section into the oscillator to suppress phase noise in the oscillator.

In the above implementation, a phase shifter may be coupled between the electrical section of the opto-electronic oscillator and the oscillator. An electrical signal circulator may be coupled to the electrical section to direct the electrical oscillation signal from the oscillator into the electrical section and to direct the electrical signal in the electrical section into the oscillator. The optical delay line may be a fiber line or an optical resonator.

Hence, one signal port of an oscillator may be used to both receive an oscillation signal from the oscillator for coupling the oscillation signal into the positive feedback loop of the opto-electronic oscillator, and feedback a feedback oscillation signal from the opto-electronic oscillator into the oscillator to stabilize the oscillator. Various one-port oscillator devices may be stabilized using an opto-electronic oscillator, such as Gunn diode oscillators and impact ionization avalanche transit-time (IMPATT) diode oscillators, Klystron or Clystron electron oscillators, backward-wave oscillators, YIG oscillators and others. In combination with recent development of ultra-high-speed photodetectors and optical modulators, opto-electronic oscillators may be used to stabilize oscillators at high frequencies in the range of tens of gigahertz and beyond 100 GHz.

A method for stabilizing an oscillator is also described as an example. In this method, an output oscillation signal from a signal port of an oscillator is directed into an electrical section of an opto-electronic oscillator having an optical section and the electrical section which form a closed loop with a positive feedback. An oscillation signal that is produced in the electrical section from an optical signal in the optical section is then injected into the signal port of the oscillator to stabilize the oscillator. If the oscillator is tunable, the oscillator can be tuned to switch between different modes of the closed loop in the opto-electronic oscillator.

These and other implementations, features, and associated advantages are described in greater detail in the drawings, the detailed description, and the claims.

BRIEF DESCRIPTION OF DRAWINGS

FIG. 1 shows an example of a stabilized oscillator system where an oscillator is coupled to an electrical section of a positive opto-electronic feedback loop of an opto-electronic oscillator.

FIG. 2 shows an implementation of the system in FIG. 1.

FIGS. 3 and 4 show additional examples of opto-electronic oscillators that may be used to stabilize the oscillator in FIGS. 1 and 2.

FIGS. 5, 6, 7, 8A and 8B show examples of whispering gallery mode resonators that may be used in the optical section of the opto-electronic feedback loop of an opto-electronic oscillator in FIGS. 1, 2, 3, and 4.

DETAILED DESCRIPTION

Opto-electronic oscillators use positive opto-electronic feedback loops with high quality factors to achieve electromagnetic oscillations at various frequencies. Examples of opto-electronic oscillators are described in, e.g., U.S. Pat.

Nos. 6,567,436, 5,929,430, 5,777,778, and 5,723,856. Such an opto-electronic oscillator includes an electrically controllable optical modulator or laser and at least one active opto-electronic feedback loop that comprises an optical section and an electrical section. The optical section and the electrical section are connected by a photodetector and the optical modulator to form a closed loop. The loop produces a desired delay and feeds the electrical signal in phase to the modulator to generate and sustain both optical modulation and electrical oscillation when the total loop gain of the active opto-electronic loop exceeds the total loss. The oscillation in such a closed loop can be various frequency spectral ranges that are outside the optical spectrum, including the radio frequency, microwave, millimeter- and sub-millimeter-wave bands. The generated oscillating signals are tunable in frequency and can have narrow spectral linewidths and low phase noise in comparison with the signals produced by other RF and microwaves oscillators.

Notably, the opto-electronic feedback based on optical storage and optical resonances allows the effective microwave Q-factor of the opto-electronic oscillator to increase proportionally to the frequency of the oscillation. This is in part because the resonance bandwidth of the opto-electronic oscillator is dictated by optical losses and thus is relatively small and is independent of the frequency of the oscillation. In this way, equivalent Q-factors for the oscillation on the order of 10^6 become available at 10 GHz at the room temperature, and ever greater Q values are available towards mm and sub-millimeter band. Such effective high Q values can be used to achieve low phase noise in the oscillations at various oscillation frequencies, including the microwave, millimeter- and sub-millimeter-wave bands.

In this application, opto-electronic oscillators are used to provide a feedback mechanism for stabilizing various target oscillators to achieve stabilized oscillations with low phase noise and high Q factors in the target oscillators. A target oscillator is coupled to the electrical section of the opto-electronic feedback loop of an opto-electronic oscillator to receive a feedback signal from the electrical section of the opto-electronic feedback loop. Under this coupling and feedback, the phase noise and frequency variation in the target oscillator can be reduced to achieve a high frequency stability and spectrally pure oscillation in the target oscillator. As a result, a variety of target oscillators, beyond closed loop oscillators with two-port electronic amplifiers and a high-Q feedback circuit, may be stabilized to produce oscillation signals with low phase noise at stabilized oscillation frequencies.

FIG. 1 illustrates an example for a stabilized oscillator system **100** where a target oscillator **110** is coupled to an electrical section **124** of a positive opto-electronic feedback loop of an opto-electronic oscillator **120**. The target oscillator **110** has one signal port that exports an output oscillation signal **111** to the electrical section **124** of the opto-electronic oscillator **120** and receives a feedback oscillation signal **112** from the opto-electronic oscillator **120**. The injection of the feedback oscillation signal **112** enforces a steady phase into the otherwise noisy target oscillator **110** and thus causes the target oscillator **110** to stabilize the oscillation frequency and reduce the phase noise in comparison to a free-running target oscillator **110**. The injection causes a frequency pulling effect or self-injection locking with a high Q external cavity. The result is a reduced linewidth and the phase noise of the oscillation in the target oscillator **110**. From another point of view, the target oscillator **110** has a Q factor lower than the Q factor of the opto-electronic oscillator. Hence, the linewidth of the oscil-

lation signal in a free-running target oscillator **110** is broader than the linewidth of the signal in the opto-electronic loop. This injection of the oscillation signal produced by the high-Q opto-electronic feedback loop effectually forces the target oscillator **110** to oscillate at a mode that matches a mode of the opto-electronic feedback loop within the narrower linewidth of the matched mode of the opto-electronic feedback loop.

The opto-electronic oscillator **120** as illustrated includes an optical modulator **121** that modulates a CW light beam to produce a modulated optical signal **101** in response to a modulation feedback control signal applied to the control port of the modulator **121**. Alternatively, a laser **121** such as a diode laser that can be directly modulated to produce a modulated laser output **101**. The modulator or laser **121** operates as an interface from the electrical section **124** to an optical section of the opto-electronic feedback loop in the opto-electronic oscillator **120**. The modulated optical signal **101** is then fed into the optical section **122** to produce a delayed modulated optical signal **102**. The optical section **122** may include an optical delay element such as a fiber delay line or an optical resonator as an optical delay element to delay and optically filter the light. In addition, the optical section **122** may include an optical amplifier to amplify the optical signal. Next in the loop, the opto-electronic oscillator **120** includes a photodetector **123** as the interface from the optical section **122** to the electrical section **124** to convert the optical signal **102** into a detector signal **103** in the electrical domain. The photodetector **123** may be implemented with various optical detectors, including high-speed traveling wave photodiodes (PDs) and uni-traveling-carrier (UTC) PDs operating at frequencies of about 100 to 300 GHz. See, e.g., Ito et al. in "InP/InGaAs uni-traveling-carrier photodiode with 310 GHz bandwidth," *Electron. Lett.* 36, page 1809 (2000).

The electrical section **124** is designed to receive the detector signal and to produce the modulation feedback control signal **104** and includes electrical circuitry for coupling with the target oscillator **110**. The electrical section **124** may also include at least one signal bandpass filter to filter the electrical signal by rejecting undesired frequency components. A signal amplifier operable at the oscillation frequency of the system may be optionally coupled in the electrical section **124** to amplify the electrical signal. The closed opto-electronic loop formed by the blocks **121**, **122**, **123**, and **124** has a total signal gain greater or equal to the total loop loss and provides an in-phase feedback to the optical modulator or laser **121** to sustain an oscillation.

The target oscillator **110** to be stabilized by the opto-electronic oscillator **120** may use one signal port for exporting the output oscillation signal **111** and for receiving the feedback oscillation signal **112**. This feedback via a single port on the target oscillator **110** allows the above stabilization mechanism to be applied to a variety of oscillators. For example, one-port oscillator devices such as Gunn diode oscillators and impact ionization avalanche transit-time (IMPATT) diode oscillators, Klystron or Clystron electron oscillators, backward-wave oscillators, YIG oscillators and others, may be coupled in the manner shown in FIG. 1 to stabilize the oscillation frequency and to reduce the phase noise.

The system **100** in FIG. 1 may be used to remove certain technical limitations on the oscillation frequencies of opto-electronic oscillators due to technical limits of certain components such as two-port RF amplifiers which may operate up to 60 GHz. High frequency oscillators operating above 60 GHz or on the order of 10^2 GHz may be stabilized based on

the design in FIG. 1 and thus extend the application of the opto-electronic oscillator to produce high frequency signal sources that may be difficult to achieve with current opto-electronic oscillators. Hence certain uniquely available RF sources (i.e., oscillators) in short millimeter (approximately 5 from 60 to 300 GHz) and submillimeter (approximately from 300 to 1000 GHz) range may be used as the target oscillator **110** in FIG. 1 and achieve reduction of the phase noise by utilizing the opto-electronic feedback.

Notably, the coupling between the target oscillator **110** and the opto-electronic oscillator **120** is via a single signal port of the target oscillator **110**. As such, the opto-electronic feedback is not coupled to and thus does not affect any control or tuning mechanism for the target oscillator **110**. Under this feedback design, the target oscillator **110** can be tuned or controlled to at different oscillation modes of the opto-electronic oscillator **120**. The original tunability of free-running poor performance oscillator **110** (for example, a tunable YIG oscillator) can be preserved in simple electro-optically stabilized version as shown in FIG. 1. Upon tuning the tunable oscillator **110**, for example, by changing current in the electromagnet in the YIG oscillator, the stabilized system **100** will be switching between different modes of the optoelectronic feedback loop in the opto-electronic oscillator **120**. The different modes of the optoelectronic feedback loop in the opto-electronic oscillator **120** may be few-ten-KHz-apart super-modes defined by a kilometer-long fiber delay, or few-MHz-apart modes defined by a fiber cavity, or few-GHz-apart modes of an optical microresonator, in the optical section **122**.

FIG. 2 shows an exemplary system **200** that implements the stabilization mechanism in FIG. 1. The system **200** includes a target oscillator **110** to be stabilized and an opto-electronic oscillator whose main components are represented by the block **201**. A CW light source **241** such as a laser is used to produce an input optical beam to an optical modulator **242** and the optical modulator **242** modulates the beam in response to the modulation feedback control signal **104** from electrical circuitry **231**. The optical modulator **242** may be implemented with high-efficiency resonance modulators based on whispering-gallery modes in microresonators made of lithium niobate or other materials that exhibit an electro-optic effect. Such a modulator modulates light under a resonator resonant condition via the electro-optic effect at frequencies to 33 GHz or higher and has high efficiency with a low controlling power down to a few milliWatts. The modulated beam produced by the modulator **242** is then fed into an optical delay line or cavity **243** to produce a long optical delay. The photodetector **123** is used to convert the optical signal from the optical delay line or cavity **243** into a detector signal **103** to electrical circuitry **232**.

The electrical section of the opto-electronic feedback loop includes the electrical circuitry **232**, a signal circulator **220**, and the electrical circuitry **231**. The circulator **220** directs the detector signal **103** to the target oscillator **110** and to direct an output oscillation signal as the modulation feedback control signal **104** to the optical modulator **242**. Hence, the target oscillator **110** is coupled to be part of the electrical section of the opto-electronic feedback loop. A phase shifter **210** is coupled between the target oscillator **110** and the circulator **220** to shift the phase of the signals between the target oscillator **110** to the opto-electronic feedback loop to provide a phase matching condition between the operating mode of the target oscillator **110** and one of the modes of the opto-electronic feedback loop. The optical delay line or cavity **243** may also be tunable to change the total loop delay

to tune the frequencies of the modes of the opto-electronic feedback loop. The target oscillator **110** may also has its own tuning mechanism to tune the oscillating frequency.

In implementing the above stabilized systems, different opto-electronic oscillators may be used. For example, FIG. 3 shows a directly-modulated diode laser **310** and its driver circuit **320** may be used to replace the separate light source **241** and the optical modulator **242** in the design in FIG. 2. The modulation feedback control signal **104** is applied to the driver circuit **320** and the driver circuit **320** produces a modulated driver control signal **321**, such as a modulated driving current, to drive the diode laser **310** to produce a modulated laser output.

FIG. 4 further shows an exemplar coupled opto-electronic oscillator that may be used to replace the main block **201** in FIG. 2. This coupled opto-electronic oscillator directly couples a laser oscillation in an optical feedback loop to an electrical oscillation in an opto-electronic feedback loop. The laser oscillation and the electrical oscillation are correlated with each other so that both the modes and stability of one oscillation are coupled with those of the other oscillation. The optical feedback loop includes a gain medium to produce a loop gain greater than unity to effectuate the laser oscillation. This optical loop may be a Fabry-Perot resonator, a ring resonator, a whispering gallery mode resonator, and other resonator configurations. The open loop gain in the opto-electronic loop also exceeds the loss to sustain the electrical oscillation. The coupling between two feedback loops is achieved by controlling the loop gain of the optical loop by an electrical signal generated by the opto-electronic feedback loop. Coupled opto-electronic oscillators can achieve a single-mode RF oscillation without a RF bandpass filter or any additional opto-electronic feedback loops. A multi-mode laser can be used. An optical resonator can be placed in either an opto-electronic feedback loop or in the optical feedback loop of a coupled opto-electronic oscillator. In the former configuration, the frequencies of the laser modes are locked to the transmission peaks of the resonator by using a frequency control circuit. Alternatively, two optical resonators may be respectively placed in the optical loop and the opto-electronic loop at the same time.

The coupled opto-electronic oscillator in FIG. 4 uses an optical loop **410** with gain as the optical feedback loop. The loop **410** may be formed by optical fiber or other optical waveguides. The optical loop **410** forms an optical ring with an optical amplifier **411**, an optical modulator **412**, and an optical delay line or cavity **243**. An optical isolator **420** may be used to ensure light in the loop **410** to run in only one direction. An optical coupler **430** is coupled to the optical loop **410** split a fraction of the light in the loop **410** to a photodetector **123** outside the loop **410** for the opto-electronic feedback. A part of the optical loop **410**, including the optical modulator **412**, the portion of the loop between the optical modulator **412** and the coupler **430**, forms part of the optical section of the opto-electronic feedback loop.

The optical modulator **412** may be an electro-optic modulator or other suitable optical modulator which can operate to modulate light in response to the modulation feedback control signal **104** from the opto-electronic loop. The optical amplifier **411** and the modulator **412** in combination effectuate a laser gain medium whose gain can be controlled and modulated by the control signal **104**. A semiconductor optical amplifier, for example, can be used to function as the combination of the amplifier **411** and the modulator **412**.

The optical delay **243** may be an optical resonator in the loop **410**. One of the advantages of placing the optical resonator **243** in the optical loop **410** is that the optical

modes inside the optical loop **410** are controlled by the modes of the resonator **243**, i.e., only the modes of the loop **410** that overlap with the modes of the resonator **243** can have sufficient gain to oscillate. Therefore, the optical frequencies of the laser are automatically aligned with the transmission peaks of the resonator **243**. This configuration eliminates the need to lock the optical loop **410** and the resonator **243** relative to each other in other OEOs with an optical resonator in the opto-electronic feedback loop. See, U.S. Pat. No. 6,567,436. In addition, the resonator **243** inside the optical loop **410** determines the quality of both the optical laser signal generated in the optical loop **410** and the oscillation signal generated in the opto-electronic loop.

The optical resonator used for the optical delay element **243** in the optical section of the opto-electronic feedback loop may be implemented in a number of configurations, including, e.g., a Fabry-Perot resonator, a fiber cavity such as a fiber Fabry-Perot cavity and a fiber ring resonator, and an optical resonator operating in one or more whispering-gallery modes (WGMs) such as microsphere, microdisk, and microring WGM resonators. Non-spherical WGM resonators may be used. These and other optical resonator configurations can reduce the physical size of the opto-electronic oscillators and allow integration of different device components and other photonic devices and components in a compact package such as a single semiconductor chip.

When an optical resonator placed in the optical section of the opto-electronic feedback loop, the following mode matching conditions should be met for the proper operation of the opto-electronic oscillator. (1) The laser frequency ν_{laser} of the CW input beam to the modulator or the center laser frequency of the directly modulated laser is within one of the transmission peaks of the optical resonator so that sufficient light can transmit through the resonator to assure the open loop gain of the opto-electronic loop greater than unity. (2) The free spectral range, FSR_{opt} , of the optical resonator is equal to one or a multiplicity of the mode spacing, $\Delta\nu_{OE\ Loop}$, of the natural modes in the opto-electronic loop. (3) The frequency ν_{OEO} of the opto-electronic oscillation of the opto-electronic oscillator equals to the multiples of the free spectral range of the resonator.

The following sections describe exemplary WGM resonator configurations suitable for the above implementations.

FIGS. **5**, **6**, and **7** illustrate three exemplary geometries for implementing the WGM resonators. FIG. **5** shows a spherical WGM resonator **1100** which is a solid dielectric sphere. The sphere **1100** has an equator in the plane **1102** which is symmetric around the z axis **1101**. A WG mode exists around the equator within the spherical exterior surface and circulates within the resonator **1100**. The spherical curvature of the exterior surface around the equator plane **1102** provides spatial confinement along both the z direction and its perpendicular direction to support the WG modes. The eccentricity of the sphere **1100** generally is low.

FIG. **6** shows an exemplary spheroidal microresonator **1200**. This resonator **1200** may be formed by revolving an ellipse (with axial lengths a and b) around the symmetric axis along the short elliptical axis **1101** (z). The eccentricity of resonator **1100** is $(1-b^2/a^2)^{1/2}$ and is generally high, e.g., greater than 10^{-1} . Hence, the exterior surface is the resonator **1200** is not part of a sphere and provides more spatial confinement on the modes along the z direction than a spherical exterior. The equator plane **1102** at the center of the resonator **200** is perpendicular to the axis **1101** (z) and the WG modes circulate near the circumference of the plane **1102** within the resonator **1200**.

FIG. **7** shows another exemplary WGM resonator **1300** which has a non-spherical exterior where the exterior profile is a general conic shape which can be mathematically represented by a quadratic equation of the Cartesian coordinates. Similar to the geometries in FIGS. **5** and **6**, the exterior surface provides curvatures in both the direction in the plane **1102** and the direction of z perpendicular to the plane **1102** to confine and support the WG modes. Such a non-spherical, non-elliptical surface may be, among others, a parabola or hyperbola.

The above three exemplary geometries in FIGS. **5**, **6**, and **7** share a common geometrical feature that they are all axially or cylindrically symmetric around the axis **1101** (z) around which the WG modes circulate in the plane **1102**. The curved exterior surface is smooth around the plane **1102** and provides two-dimensional confinement around the plane **1102** to support the WG modes.

Notably, the spatial extent of the WG modes in each resonator along the z direction **1101** is limited above and below the plane **1102** and hence it may not be necessary to have the entirety of the sphere **1100**, the spheroid **1200**, or the conical shape **1300**. Instead, only a portion of the entire shape around the plane **1102** that is sufficiently large to support the whispering gallery modes may be used to for the WGM resonator. For example, rings, disks and other geometries formed from a proper section of a sphere may be used as a spherical WGM resonator.

FIGS. **8A** and **8B** show a disk-shaped WGM resonator **1400** and a ring-shaped WGM resonator **1420**, respectively. In FIG. **8A**, the solid disk **1400** has a top surface **1401A** above the center plane **102** and a bottom surface **1401B** below the plane **1102** with a distance H. The value of the distance H is sufficiently large to support the WG modes. Beyond this sufficient distance above the center plane **1102**, the resonator may have sharp edges as illustrated in FIGS. **7**, **8A**, and **8B**. The exterior curved surface **1402** can be selected from any of the shapes shown in FIGS. **5**, **6**, and **7** to achieve desired WG modes and spectral properties. The ring resonator **1420** in FIG. **8B** may be formed by removing a center portion **1410** from the solid disk **1400** in FIG. **8A**. Since the WG modes are present near the exterior part of the ring **1420** near the exterior surface **1402**, the thickness h of the ring may be set to be sufficiently large to support the WG modes.

In general, an optical coupler is needed to couple optical energy into or out of the WGM resonator by evanescent coupling. Angle-polished fiber tips, waveguides, and GRIN lenses or prisms may be used as the optical couplers. In addition, evanescent couplers such as an coupler formed from photonic bandgap materials may be used for coupling with the resonators.

In summary, only a few implementations are disclosed. However, it is understood that variations and enhancements may be made.

The invention claimed is:

1. A device, comprising:

an oscillator producing an electrical oscillation signal; and an opto-electronic oscillator comprising a positive feedback loop which comprises an optical section, an electrical section, and an optical detector to connect the optical section and the electrical section, wherein the optical section comprises an optical modulator modulating light under control of an electrical output signal from the electrical section and an optical delay line to receive an optical output of the optical modulator, wherein the electrical section is coupled to receive the electrical oscillation signal from the oscillator and to

9

send an electrical signal in the electrical section into the oscillator to suppress phase noise in the oscillator.

2. A device as in claim 1, further comprising a phase shifter coupled between the electrical section of the opto-electronic oscillator and the oscillator.

3. A device as in claim 1, further comprising an electrical signal circulator coupled to the electrical section to direct the electrical oscillation signal from the oscillator into the electrical section and to direct the electrical signal in the electrical section into the oscillator.

4. A device as in claim 1, wherein the optical delay line comprises a fiber line.

5. A device as in claim 1, wherein the optical delay line comprises a fiber cavity.

6. A device as in claim 1, wherein the optical delay line comprises an optical resonator.

7. A device as in claim 6, wherein the optical resonator comprises a whispering gallery mode resonator.

8. A device as in claim 7, wherein the whispering gallery mode resonator is a spherical resonator.

9. A device as in claim 7, wherein the whispering gallery mode resonator is a spheroidal microresonator.

10. A device as in claim 7, wherein the whispering gallery mode resonator is a spherical disk resonator.

11. A device as in claim 1, wherein the opto-electronic oscillator comprises a laser to supply said light to the optical modulator and to the optical delay line.

12. A device as in claim 1, wherein the optical modulator is a directly modulated laser to produce a modulated laser beam.

13. A device as in claim 1, wherein the optical modulator comprises a whispering gallery mode resonator that exhibits an electro-optic effect and modulates light via the electro-optic effect.

14. A device as in claim 1, further comprising a laser cavity in which the optical modulator is placed and to which the optical section of the positive feedback loop is coupled, wherein the optical modulator is operable to modulate laser light produced by the laser cavity, and at least a portion of the modulated laser light is coupled to the optical section of the positive feedback loop.

15. A device as in claim 1, wherein the optical detector is a high-speed traveling wave photodiode or a uni-traveling-carrier photodiode.

16. A device as in claim 1, wherein the oscillator is a tunable oscillator and the device further comprising a tuning

10

mechanism to tune the oscillator to switch an oscillation mode between two different modes of the opto-electronic oscillator.

17. A device as in claim 1, wherein the oscillator is coupled to the electrical section via a single port in the oscillator for both receiving the electrical oscillation signal from the oscillator and sending the electrical signal into the oscillator.

18. A device as in claim 1, wherein the oscillator is a Gunn diode oscillator.

19. A device as in claim 1, wherein the oscillator is an impact ionization avalanche transit-time (IMPATT) diode oscillator.

20. A device as in claim 1, wherein the oscillator is a Klystron oscillator.

21. A device as in claim 1, wherein the oscillator is a backward-wave oscillator.

22. A device as in claim 1, wherein the oscillator is a YIG oscillator.

23. A method for stabilizing an oscillator, comprising: directing an output oscillation signal from a signal port of an oscillator into an electrical section of an opto-electronic oscillator having an optical section and the electrical section which form a closed loop with a positive feedback; and

injecting an oscillation signal that is produced in the electrical section from an optical signal in the optical section into the signal port of the oscillator to stabilize the oscillator.

24. A method as in claim 23, wherein the oscillator is tunable, the method further comprising tuning the oscillator to switch between different modes of the closed loop in the opto-electronic oscillator.

25. A method as in claim 23, further comprising shifting a phase of each signal coupled between the oscillator and the closed loop to match a mode of the oscillator with a mode of the closed loop.

26. A method as in claim 23, wherein the opto-electronic oscillator is a coupled opto-electronic oscillator.

27. A method as in claim 23, further comprising using an optical resonator in the optical section of the closed loop.

* * * * *