

NASA/TM 2008-214569



Advanced Diagnostic and Prognostic Testbed (ADAPT) Testability Analysis Report

*John Ossenfort,
E.A.S.I. / NASA Ames Research Center*

National Aeronautics and
Space Administration

Ames Research Center
Moffett Field, California, 94035-1000

January 2008

The NASA STI Program Office . . . in Profile

Since its founding, NASA has been dedicated to the advancement of aeronautics and space science. The NASA Scientific and Technical Information (STI) Program Office plays a key part in helping NASA maintain this important role.

The NASA STI Program Office is operated by Langley Research Center, the Lead Center for NASA's scientific and technical information. The NASA STI Program Office provides access to the NASA STI Database, the largest collection of aeronautical and space science STI in the world. The Program Office is also NASA's institutional mechanism for disseminating the results of its research and development activities. These results are published by NASA in the NASA STI Report Series, which includes the following report types:

- **TECHNICAL PUBLICATION.** Reports of completed research or a major significant phase of research that present the results of NASA programs and include extensive data or theoretical analysis. Includes compilations of significant scientific and technical data and information deemed to be of continuing reference value. NASA's counterpart of peer-reviewed formal professional papers but has less stringent limitations on manuscript length and extent of graphic presentations.
- **TECHNICAL MEMORANDUM.** Scientific and technical findings that are preliminary or of specialized interest, e.g., quick release reports, working papers, and bibliographies that contain minimal annotation. Does not contain extensive analysis.
- **CONTRACTOR REPORT.** Scientific and technical findings by NASA-sponsored contractors and grantees.
- **CONFERENCE PUBLICATION.** Collected papers from scientific and technical conferences, symposia, seminars, or other meetings sponsored or cosponsored by NASA.
- **SPECIAL PUBLICATION.** Scientific, technical, or historical information from NASA programs, projects, and missions, often concerned with subjects having substantial public interest.
- **TECHNICAL TRANSLATION.** English-language translations of foreign scientific and technical material pertinent to NASA's mission.

Specialized services that complement the STI Program Office's diverse offerings include creating custom thesauri, building customized databases, organizing and publishing research results . . . even providing videos.

For more information about the NASA STI Program Office, see the following:

- Access the NASA STI Program Home Page at <http://www.sti.nasa.gov>
- E-mail your question via the Internet to help@sti.nasa.gov
- Fax your question to the NASA Access Help Desk at (301) 621-0134
- Telephone the NASA Access Help Desk at (301) 621-0390
- Write to:
NASA Access Help Desk
NASA Center for AeroSpace Information
7121 Standard Drive
Hanover, MD 21076-1320

NASA/TM 2008-214569



Advanced Diagnostic and Prognostic Testbed (ADAPT) Testability Analysis Report

*John Ossenfort,
E.A.S.I. / NASA Ames Research Center*

National Aeronautics and
Space Administration

Ames Research Center
Moffett Field, California, 94035-1000

January 2008

Available from:

NASA Center for AeroSpace Information
7121 Standard Drive
Hanover, MD 21076-1320
(301) 621-0390

National Technical Information Service
5285 Port Royal Road
Springfield, VA 22161
(703) 487-4650

Advanced Diagnostic and Prognostic Testbed (ADAPT) Testability Analysis Report

1. Introduction

As system designs become more complex, determining the best locations to add sensors and test points for the purpose of testing and monitoring these designs becomes more difficult. Not only must the designer take into consideration all real and potential faults of the system, he or she must also find efficient ways of detecting and isolating those faults. Because sensors and cabling take up valuable space and weight on a system, and given constraints on bandwidth and power, it is even more difficult to add sensors into these complex designs after the design has been completed. As a result, a number of software tools have been developed to assist the system designer in proper placement of these sensors during the system design phase of a project. One of the key functions provided by many of these software programs is a testability analysis of the system – essentially an evaluation of how “observable” the system behavior is using available tests. During the design phase, testability metrics can help guide the designer in improving the inherent testability of the design. This may include adding, removing, or modifying tests; breaking up feedback loops, or changing the system to reduce fault propagation. Given a set of test requirements, the analysis can also help to verify that the system will meet those requirements. Of course, a testability analysis requires that a software model of the physical system is available. For the analysis to be most effective in guiding system design, this model should ideally be constructed in parallel with these efforts.

The purpose of this paper is to present the final testability results of the Advanced Diagnostic and Prognostic Testbed (ADAPT) after the system model was completed. The tool chosen to build the model and to perform the testability analysis with is the Testability Engineering and Maintenance System Designer (TEAMS-Designer). The TEAMS toolset is intended to be a solution to span all phases of the system, from design and development through health management and maintenance. TEAMS-Designer is the model-building and testability analysis software in that suite.

2. The ADAPT Model

The first step towards analyzing the testability of a system is to create the software model. The ADAPT model created in TEAMS-Designer is a multi-signal dependency model which captures the ADAPT system’s basic structure, interconnections, sensors, and failure modes. The model is then able to link a given failure mode with a test or multiple tests based on signals that are propagated through the structure of the model. In total, there are 712 failure sources in the ADAPT model and 281 tests corresponding to approximately 150 sensors on the system. Failure modes in the ADAPT model might include a relay being stuck open or closed, low battery impedance, or low voltage at a sensor. Signals (also known as functions) attached to these failure modes might include Power_On, Relay_Open, Relay_Closed, Battery_Output_Current, and multiple others. Figure 1 shows a portion of the model representing one of two battery chargers, with typical fault modes and functions displayed. This component block connects

with other blocks via links, along which the functions propagate to capture the hierarchy and fault behavior of the whole system.

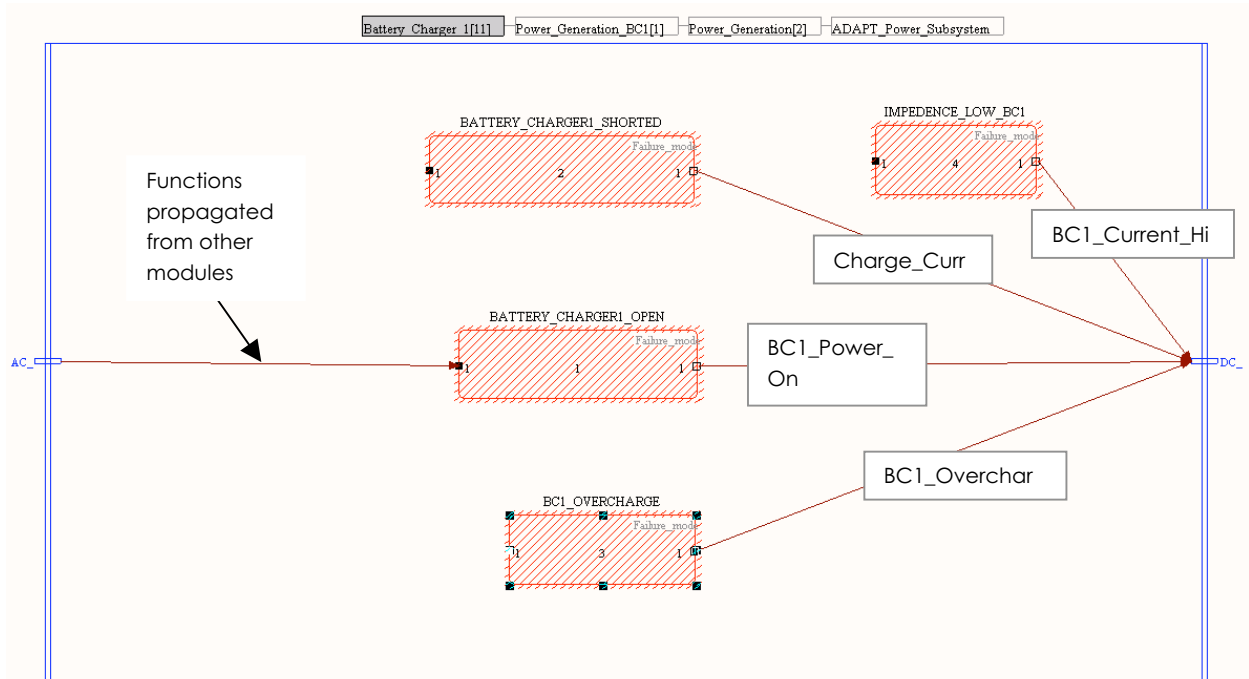

Figure 1: Battery Charger component in TEAMS, with functions labeled

Once the failure modes and signals are created, tests can then be attached to the model to test for these functions and implicate or clear a particular fault. A dependency between a test and a failure source is established if they both contain the same function and they are interconnected with links (with the test being downstream of the failure source). For example, a voltage sensor named EI165 on ADAPT is able to detect a low voltage, causing the test EI165_VOLTAGE_HI to fail. This test has one function associated with it: Power_On. By tracing this function through the model from the test point back to the source, TEAMS is able to determine all possible locations in the model where this signal could have been interrupted.

For ease of understanding, identical names were used for a test point and the test hosted by it. The names are also indicative of the category a specific test belongs to. For example, ESH141_POSITION_CLOSED refers to a test that is performed using a contact position sensor in a switch, while EI125_VOLTAGE_LO refers to a test that is performed on a voltage signal from sensor EI125.

The initial ADAPT model was created by Qualtech Systems (QSI) as part of a phase II Small Business Innovation Research (SBIR) project (contract number NNA06AA51Z). At the top level, the model consists of five functional blocks representing Power Generation, Power Storage, Power Distribution, Loads, and Monitor Control. Each block groups components, switches, and sensors into a module. In Figure 2, the top level of the hierarchy is displayed, showing the functional blocks. These blocks are described in more detail below.

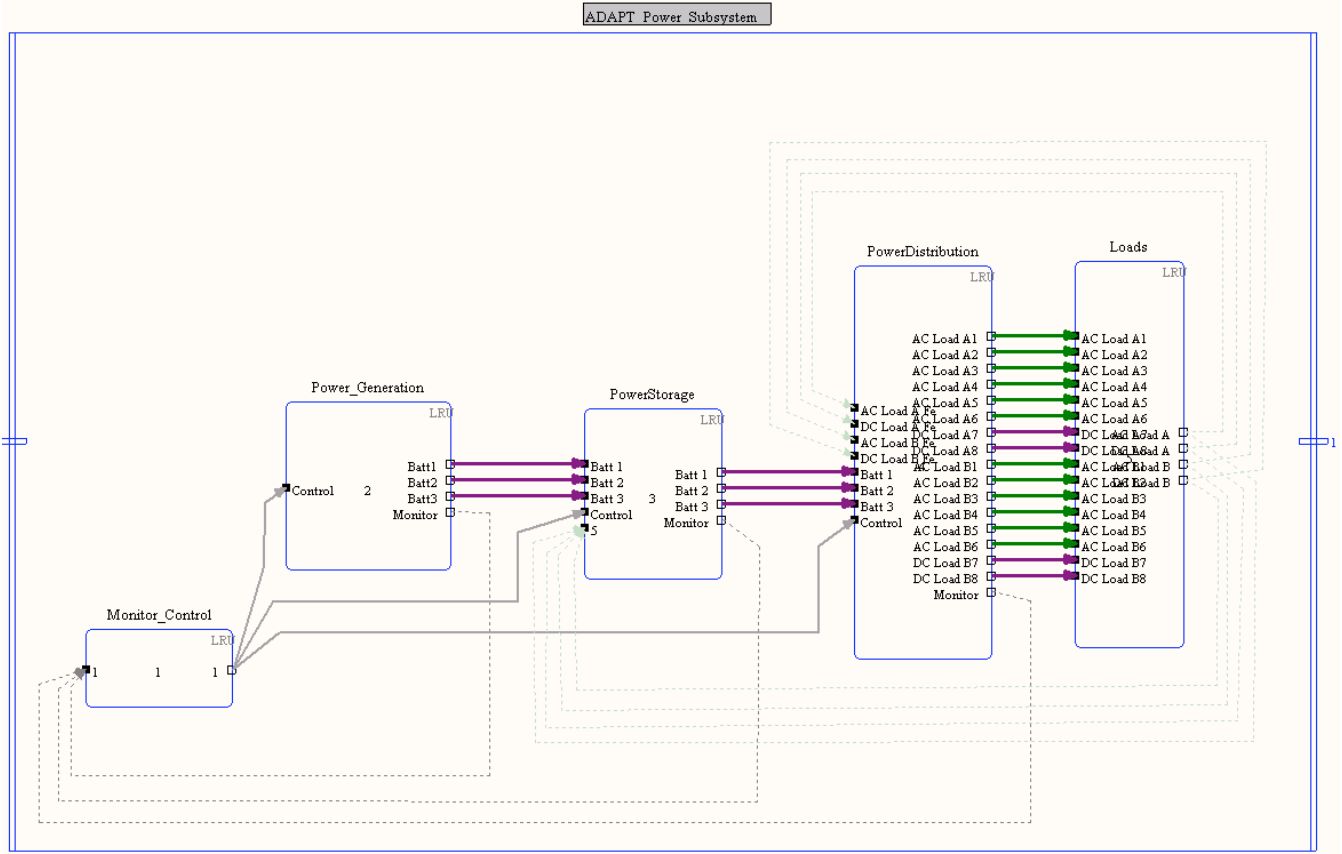

Figure 2: Top-level view of TEAMS ADAPT model

Power Generation – The Power Generation module represents the function of supplying primary power to the testbed. Specifically, this consists of two battery chargers running on utility power and the associated switches and circuit breakers connecting these chargers to the Power Storage module.

Power Storage – The Power Storage module in the ADAPT model contains three sets of two 12-volt DC lead acid batteries for delivering stored power to the loads. Other components in this block include temperature sensors attached to the batteries, panel meters for manual observation of the batteries, and circuit breakers and relays.

Power Distribution – This module connects the Power Storage function to the Loads, allowing for multiple configurations between the three battery sets and two load banks. The switches inside this module also must enforce rules restricting a load bank from being powered by more than one battery set.

Loads – This block contains two load banks, each bank with six (6) AC and two (2) DC outputs. In the present configuration, the load banks are designed to support primary and backup loads for a light bank of three bulbs, a single lamp, a water pump, and two fans. This functional block also contains temperature, light, flow, and rate sensors for monitoring of these loads, along with two AC inverters and the necessary switches and circuit breakers.

Monitor Control – The final block contains the control switches for changing between switch modes based on commands sent to the testbed. It also contains components to represent sensor outputs in the system which can be used for real-time monitoring of the system with tools such as TEAMS-RT. On the testbed, this block corresponds to the National Instruments backplanes and associated LabVIEW software.

Once the model was built, several types of labels were added to assist in testability analysis. [Of these types,](#) Technology labels were used to logically divide up the model into two basic sections. Because the Monitor_Control block does not represent electrical power system components on the testbed, it is described under a separate technology label (Monitor-Control) while the remaining four blocks are described under another label (AdaptPowerSystem). Technology labels are described in more detail under section 5 below.

3. Failure Modes in the System

In its present state, the ADAPT model has 712 failure sources identified. The AdaptPowerSystem portion of the model (all sections excluding the Monitor Control block) contains 489 failure sources. Most components have multiple failure states and fall into one of several categories. Relays, for instance, can fail in four basic ways: both the contact and the coil can independently fail open or closed. Table 1 lists the major components and their failure modes.

Device Type	Symbol in Model	Faults
Relay	EY	Coil Open
		Coil Closed
		Contact Open
		Contact Closed
Relay Contact Position Sensor	ESH	Sensor Open
		Sensor Closed
Light Transducer	LT	Low Signal (Failed Low)
Circuit Breaker	CC/BC	Stuck Open
		Stuck Closed
		Position Closed
		Position Open
Circuit Breaker Position Sensor	ISH	Sensor Open
		Sensor Closed
Voltage Indicator	EI	Stuck High
		Stuck Low
Charge Controller	CHG_CTLR	Open
		Short
		Impedance Low
Battery Charger	Battery Charger	Short
		Open
		BC Overcharge
		BC Impedance Low
Current Transducer	IT	Stuck Open
		Stuck Closed
Battery	Battery	Impedance Low
		Voltage Low
		Overheated

Panel Meter	PNL_MTR	Meter Indicator Fault
Temperature Sensor	TE	Output High
Frequency Sensor	ST	Sensor Open
		Sensor Closed
Flow Sensor	FT	Sensor Open
		Sensor Closed
Loads	Load	Open
		Short
		Impedance Fault
Inverter	Inverter	Short
		Frequency Fault
		Low Output

Table 1: Failure sources in TEAMS ADAPT model, listed by device type

4. Testability Analysis

Once the process of adding tests begins, the testability analysis is a good way to determine the best locations for adding additional test points. One reason for using a testability analysis to guide sensor placement is to trade off the cost of adding additional sensors against the benefit gained by increasing the information available for monitoring system behavior. The risks of making uninformed decisions regarding sensors and sensor placement are summarized nicely here:

There is no straightforward relation between the number of sensors and diagnosability of the systems; increasing the number of sensors alone does not guarantee a higher level of diagnosability. The relevance of information provided by an additional sensor and its correlation with information provided by other sensors must also be taken into account. Besides the issue of diagnosability, we also consider economics issues. We must provide a sensor system that achieves a desired degree of diagnosability at the lowest possible cost.[3]

Inherent tradeoffs involved in adding additional sensors to the system include sensor cost, sensor weight, bandwidth limitations for transmitting telemetry and other considerations. For flight applications, and space flight in particular, weight plays a crucial role in determining what can be added to the system. If current sensors, for instance, generally weigh more than voltage sensors, then voltage sensors might be a better choice if the gain/loss in fault detection capability between them. The designers must take into account these factors while also ensuring a certain amount of redundancy to allow for potential sensor failures.

One thing to note when running a testability analysis is that TEAMS-Designer makes a single-fault assumption when building its diagnostic tree. This means that it will not consider the possibility of multiple faults combining to give the same signature as a single fault. If this were not the case, the tree would grow to an overwhelmingly large size to include double, triple, and even larger fault combinations. A single-fault assumption also significantly helps to reduce the size of ambiguity groups.

5. Testability Options

There are several options available to the user when running a testability analysis in TEAMS-Designer. Many of these options are tied to how the user chooses to model their system. More granularity may be achieved by using options such as technologies and test labels to limit an analysis to specific parts of the model. This section will describe some of the options available to do this. For reference, Figure 3 displays the menu where many of these selections are specified.

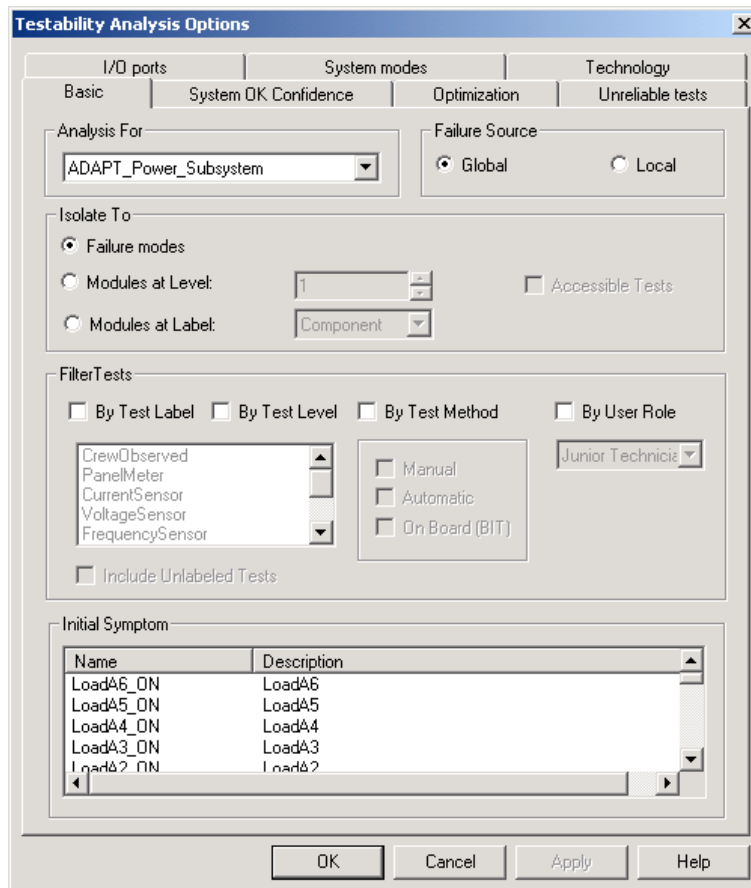

Figure 3: TEAMS Testability Analysis Options pop-up menu

Analysis For – The simplest way to limit a testability analysis, this option allows the user to choose a specific module/component for analysis. This can either be a top-level component containing other components or a lower-level failure mode. If something other than the top-level “system” component is chosen, then either global or local analysis should also be selected. *Global analysis* takes into account failures external to that component but assigns their failure rate to zero. *Local analysis* only looks at local components and local failures inside the module specified. The result of local analysis is generally a smaller ambiguity group set with a smaller number of components in each group, giving a higher isolation rate. This setting might be useful for more effective fault isolation if there are a large number of faults propagating from one module to another.

Technologies – Another way to restrict analysis to a particular set of modules is to use Technologies. When building the model, a technology label can be applied to any component and a component may fall under multiple technologies. During testability analysis, multiple technologies may be selected. If technologies are not used it is assumed all components (and technologies) are to be included in the analysis. The primary reason for using a technology label during testability analysis is to exclude any failure sources outside of those technologies. The ADAPT model is divided into two major technology labels: AdaptPowerSystem and Monitor-Control (as previously discussed in section 2).

Test Labels – It is possible to not only limit the analysis at a component level, but also at the level of tests. Any test point may belong to a particular class grouped by a common label. These test labels are user defined, and when running a testability analysis the user can choose any number of test labels to isolate to. Limiting an analysis using test labels does not decrease the number of failure sources in the problem set unless combined with technology labels; instead, it limits the number of tests used in fault detection and isolation. In the ADAPT model, test labels distinguish between different types of sensors, such as voltage, current, or temperature sensors.

System Modes – In TEAMS, a system mode is a collection of switch modes within the model. Because many of the test points should only be active in a given system configuration (i.e., it is unnecessary to test for high voltage at the loads when the loads are not connected to the battery) it is a requirement that these configurations be separately defined but also included as part of a testability analysis in order to obtain a complete view of the system.

Test Method – There are three test methods defined by default in TEAMS: Manual, Automatic, and On-Board (BIT) Test. Depending on the kind of tests involved, there might be greater or lesser coverage in the testability analysis. A manual test could include the use of a voltmeter or visual observation, potentially useful information in order to fully isolate a fault within a given candidate list. The ADAPT model contains 242 automatic tests, 39 manual tests, and 0 on-board tests. Most of the manual tests also correspond to the “Crew Observed” test label and include such questions as, “Is Light A on?”

Finally, TEAMS allows the user to isolate to either components or failure modes (the lowest-level component). It is also possible to isolate to a particular level of hierarchy within the model. For the purpose of this paper, we are primarily interested in isolating to failure modes.

6. Testability Output

After performing a testability analysis in TEAMS-Designer, the user is presented with a number of testability figures of merit (TFOMs) along with other information to help gauge the observability of the model under test. An example of the testability report is shown in Figure 4.

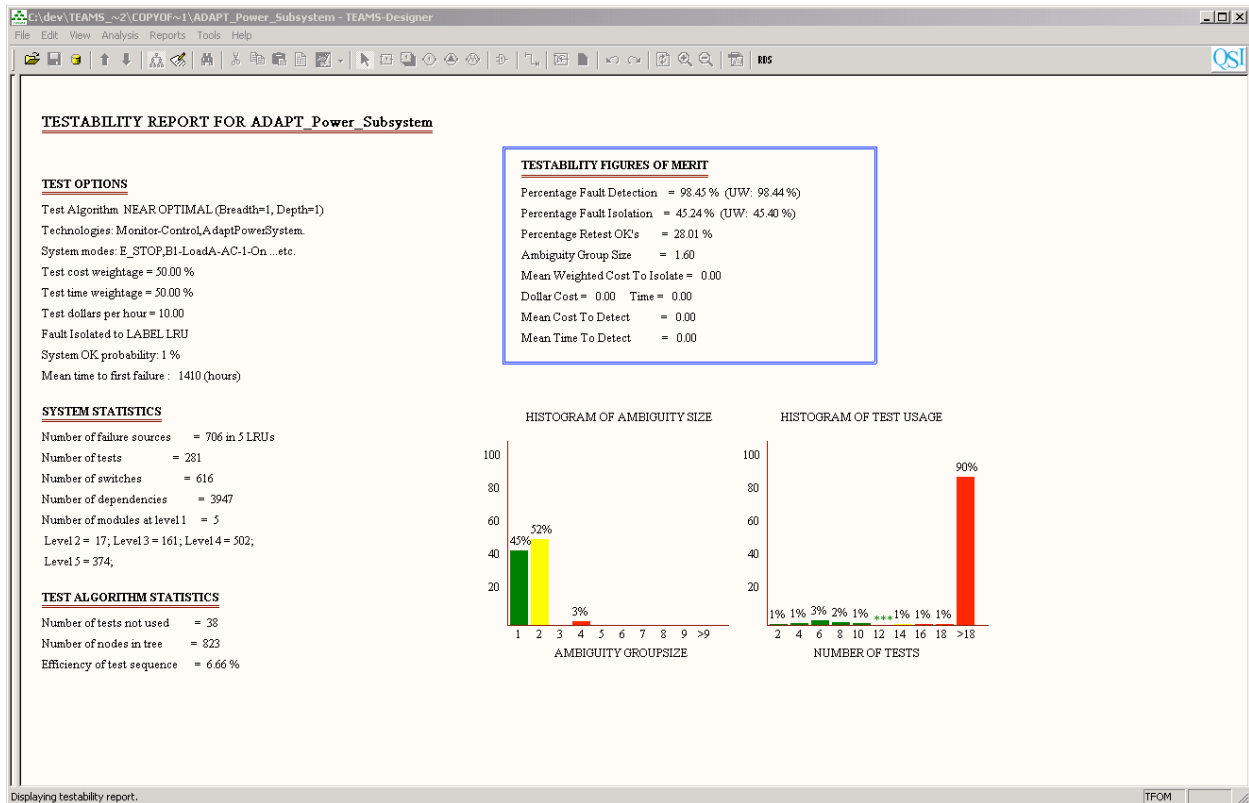

Figure 4: TEAMS Testability Analysis Report example output

Fault Detection vs. Fault Isolation – The two principal metrics for any testability analysis are *fault detection* and *fault isolation*. Respectively, these metrics measure the ability of the system to detect the presence of a fault that has occurred, and to identify that particular fault and distinguish it without ambiguity from other faults based on available data. If the fault detection of a system is very high, then it can be said to have high fault observability. The TEAMS-Designer tool reports these numbers as Percentage Fault Detection and Percentage Fault Isolation.

Ambiguity Group Size – Another related metric to provide additional insight into the system is *ambiguity group size*. The ambiguity group size indicates the level of fault isolation available in the model. If a given fault cannot be isolated to a single component, it will have an ambiguity group size of greater than one. If there are many large ambiguity groups, it may be necessary to add additional tests to the system to break these groups up. At the same time, it may not be necessary to isolate all faults to individual components if they exist within a single Line Replaceable Unit (LRU).

Number of tests – As the name indicates, this is the number of tests being used in the current testability analysis. This number includes test points throughout the entire ADAPT model, but may be limited by choosing a subset of test labels.

Tests not used – These are tests that were not needed for the section of the model being tested. A test will not be used for any of the following three reasons: (a) it has no coverage, meaning it does not detect anything – this could be the case if using switch/system modes and the path to the test point is broken,

(b) it has the same test/dependency signature as another cheaper test, or (c) the same faults can be isolated using a combination of other tests.

Number of failure sources – The number of failure modes in the model or section of the model under test.

7. Test Results

A testability analysis was run on the model using a variety of test labels and using both automatic and manual test methods. The goal of this analysis was to identify the most efficient of the sensor groups and to potentially identify ways of increasing efficiency in fault detection or fault isolation. For the examples presented in this paper, all system modes were used and therefore the maximum number of tests in the system were made available for fault detection and isolation.

In the first round of tests, the most useful comparison deals with using different types of sensors to detect the entire fault set. The analysis was isolated to the AdaptPowerSystem technology group, which represents the electrical power system components of ADAPT. A testability analysis was performed for this technology group using each category of test label, each label representing a different sensor or input type. This information is useful in measuring how a given sensor type performs in detecting faults in the model exclusive of any other sensors.

To start with, the testability analysis gives some basic, useful information about the system. This information includes how many modules, failure sources, tests, and switches are present in the section of the model under analysis. Table 2 displays these attributes for components in the AdaptPowerSystem technology group.

Number of failure sources	488
Number of switches	616
Number of dependencies	3948
Number of modules at level 1	5
Number of modules at level 2	17
Number of modules at level 3	161
Number of modules at level 4	502
Number of modules at level 5	374

Table 2: AdaptPowerSystem technology label attributes

The number of modules at each level begins with the topmost level of the hierarchy, level one, and moves down toward the individual failure modes defined in the model. The failure sources are mostly located at the bottom two levels, but they can also be found throughout the model.

In the table below we break down the types of sensors by test label and provide the results of the analysis.

Test Label	All	Crew Observed	Panel Meters	Current Sensors	Voltage Sensors	Frequency Sensors	Flow Sensors	Temp. Sensors	CB Position Sensors	Relay Position Sensors	Light Meters
Percentage Fault Detection	98.36%	29.51%	15.98%	31.76%	39.14%	14.34%	13.11%	18.44%	12.30%	32.99%	13.11%
Percentage Fault Isolation	73.03%	3.25%	0.61%	6.90%	7.10%	0.00%	0.20%	1.22%	0.81%	0.00%	0.00%
Percentage Retest OK's	16.43%	87.01%	92.69%	84.92%	82.45%	95.89%	96.70%	92.69%	93.71%	84.28%	97.11%
Ambiguity Group Size	1.59	245.06	346.40	229.93	183.80	360.14	370.77	326.81	377.04	221.59	370.98
Number of tests	281	32	7	42	64	6	4	20	28	76	2
Number of tests not used	45	0	0	7	18	0	0	5	0	0	0
Number of nodes in tree	821	127	69	147	171	39	31	71	61	153	27
Efficiency of Test Sequence	6.82%	8.80%	9.65%	6.86%	6.90%	14.12%	15.56%	10.14%	6.05%	4.76%	18.93%

Table 3: AdaptPowerSystem testability analysis results using a single test label

The number of tests for individual test labels adds up to the total for all test labels, so no unlabeled tests have been excluded from the model. However, the number of unused tests for each test label does not add up to the total unused tests, indicating by combining tests from various types of sensors, some of the testing that would otherwise be necessary can be eliminated. This evidence highlights something that is often overlooked in sensor design and placement, and that is the interplay between sensors.

Judging from the numbers shown in Table 3, it becomes clear that the voltage sensors have higher rates of both fault detection and fault isolation than other sensor groups when used in isolation. Current sensors and relay position sensors also were represented fairly well, although relay sensors were not as effective at fault isolation. Unfortunately, a problem with basing conclusions solely on the table above is that the percentage of fault detection for a particular type of test does not take into account the other tests that might also be able to detect those same faults. In the next dataset the same analysis was run, but rather than isolate each test label, the full set of sensors was used and a single test label was removed from the set. This test makes the usefulness of a particular type of sensor clearer. From these numbers it can be determined just how much “testability” of the system is lost if one type of test is completely removed. Using 98.36% and 73.03% to represent baseline testability using all sensors, we calculate the percentage lost by removing each sensor group in the final two rows. The results of this test can be seen in Table 4.

Test Label	All	No Crew Observed	No Panel Meters	No Current Sensors	No Voltage Sensors	No Frequency Sensors	No Flow Sensors	No Temp. Sensors	No CB Position Sensors	No Relay Position Sensors	No Light Meters
Percentage Fault Detection	98.36%	92.42%	96.31%	88.52%	89.34%	96.72%	97.54%	93.85%	93.44%	84.22%	97.95%
Percentage Fault Isolation	73.03%	59.44%	68.16%	62.28%	57.61%	72.22%	72.22%	69.38%	61.06%	37.53%	72.63%
Number of tests	281	249	274	239	217	275	277	261	253	205	279
Number of tests not used	45	45	43	33	14	45	45	40	41	41	45
Percentage Fault Detection Lost	N/A	5.94%	2.05%	9.84%	9.02%	1.64%	0.82%	4.51%	4.92%	14.14%	0.41%
Percentage Fault Isolation Lost	N/A	13.59%	4.87%	10.75%	15.42%	0.81%	0.81%	3.65%	11.97%	35.50%	0.40%

Table 4: AdaptPowerSystem testability analysis results using all tests, except test label indicated

From these data it can be seen that in terms of fault detection, the most comprehensive sensor groups seem to be the relay position sensors, current sensors, and voltage sensors. It should be noted that these numbers are skewed towards those labels with a greater number of sensors compared to other sensor groups. Unfortunately a one-to-one comparison between test labels is difficult to quantify because some of the sensors are specific to certain parts of the model and to certain signals in particular. The flow sensors and light meters, for instance, are only applicable at the load level and it would be useless to add additional sensors of this type to the testbed in order to determine the system health at another location.

As mentioned earlier, the addition of sensor combinations shows increasing gains in the number of tests not used. Looking at these numbers, it would appear that voltage sensors contribute the most to reducing the number of tests needed in a diagnosis of the system. This number is misleading, however, because it includes voltage sensor tests that would otherwise not have been added. Several of the other test labels offer higher gains here, after filtering out test points of that test label type. CB position sensors reduce the number of tests needed by four (4), relay sensors reduce the number of tests by four (4), current sensors reduce the tests by three (3), and panel meters reduce the tests by two (2) in conjunction with other test groups and exclusive of their respective sensor type. Unfortunately these gains are only realized when multiple system modes in the model are used. As the number of system modes decrease, the number of accessible tests becomes fewer, eliminating these combinations. It would also be incorrect to assume that any sensors can be eliminated from the system without a loss in testability. The majority of sensors are represented in the model by at least two different test points: a high and a low test, or an open and closed test for relay sensors and circuit breakers. Some voltage and current sensors are represented by three test points, one for each battery configuration. Of the redundant tests, none include all test points for a given sensor.

8. Test Results by Module

In the following series of tables (Tables 5-8) the testability analysis is divided among the four main top-level components. By isolating these functional blocks, one can see which areas of the testbed are more or less observable as well as which sensor groups are most effective at fault detection and isolation for each block. The “local” setting was used when running each testability analysis on the component group, so only failure sources local to the component are considered. All tests in the model of the given “Test Label” type are included.

Test Label	All	Crew Observed	Panel Meters	Current Sensors	Voltage Sensors	Frequency Sensors	Flow Sensors	Temp. Sensors	CB Position Sensors	Relay Position Sensors	Light Meters
Percentage Fault Detection	100.00%	12.90%	22.58%	58.06%	38.71%	12.90%	12.90%	25.81%	12.90%	16.13%	12.90%
Percentage Fault Isolation	61.70%	0.00%	3.19%	3.19%	15.96%	0.00%	0.00%	0.00%	0.00%	0.00%	0.00%
Ambiguity Group Size	1.57	72.04	57.1	18.92	36.48	72.04	72.04	52.88	71.78	66.80	72.04
Number of failure sources	93	93	93	93	93	93	93	93	93	93	93
Number of tests	281	32	7	42	64	6	4	20	28	76	2
Number of tests not used	230	31	3	26	45	5	3	13	22	70	1

Table 5: ADAPT Power Storage component, testability analysis results by test label

The Power Storage module is one of the most diversified of the top-level components in terms of sensors. It contains current and voltage sensors, CB position sensors, relay sensors, temperature sensors, and panel meters. The module is shown to have 100% fault detection, but only 61.70% fault isolation. Looking more closely at the components that make up this module, part of the reason for the low isolation rate is due to the battery. Rather than using a true 24-volt battery, the ADAPT testbed uses two 12-volt batteries connected in series. Because the current sensors downstream of the battery cannot differentiate between an increase in the current of one battery in the set versus another – possibly indicating a low-impedance fault – an ambiguity group is created for each battery set. A similar issue exists for the low-voltage condition between the batteries. If each set of batteries were replaced with a single 24-volt battery, using only existing sensors the Percentage Fault Isolation for Power Storage would increase to 74.33% (+12.63%) and overall Percentage Fault Isolation for the system increases to 75.50% (+2.47%).

Test Label	All	Crew Observed	Panel Meters	Current Sensors	Voltage Sensors	Frequency Sensors	Flow Sensors	Temp. Sensors	CB Position Sensors	Relay Position Sensors	Light Meters
Percentage Fault Detection	97.32%	42.86%	10.71%	25.00%	33.93%	17.86%	15.18%	16.07%	11.61%	44.64%	14.29%
Percentage Fault Isolation	87.51%	0.00%	0.00%	5.33%	2.67%	0.00%	0.00%	0.00%	0.89%	0.00%	0.00%
Ambiguity Group Size	1.31	75.33	179.95	127.83	99.94	152.93	163.31	159.67	176.35	70.71	166.69
Number of failure sources	224	224	224	224	224	224	224	224	224	224	224
Number of tests	281	32	7	42	64	6	4	20	28	76	2
Number of tests not used	152	0	3	27	44	0	1	16	16	28	0

Table 6: ADAPT Power Distribution component, testability analysis results by test label

The Power Distribution component is also fairly diversified in its sensors, represented here in Table 6. This module has the greatest numbers of failure sources by far, more than double that of the next highest module. This helps to explain why the Percentage Fault Isolation for individual test labels is extremely low and the Ambiguity Group Size for each label is very high. Obviously it will be more difficult to detect and isolate faults to the same percentage as in a module with fewer fault modes. Surprisingly, despite the low individual numbers, when all tests are combined it still reaches above 80% fault isolation. The Crew Observed tests are surprisingly effective for fault detection here because of this module's strong ties to the Loads module. This module has the largest number of relays in the system, explaining the high fault detection gained from using relay position sensors.

Test Label	All	Crew Observed	Panel Meters	Current Sensors	Voltage Sensors	Frequency Sensors	Flow Sensors	Temp. Sensors	CB Position Sensors	Relay Position Sensors	Light Meters
Percentage Fault Detection	98.02%	0.00%	32.67%	28.71%	62.38%	0.00%	0.00%	1.98%	21.78%	45.54%	0.00%
Percentage Fault Isolation	64.71%	0.00%	0.00%	2.94%	0.98%	0.00%	0.00%	1.96%	1.96%	0.00%	0.00%
Ambiguity Group Size	1.71	102	47.83	53.47	17.71	102	102	98.06	63.28	31.71	102
Number of failure sources	101	101	101	101	101	101	101	101	101	101	101
Number of tests	281	32	7	42	64	6	4	20	28	76	2
Number of tests not used	237	32	4	34	49	6	4	18	18	54	2

Table 7: ADAPT Power Generation component, testability analysis results by test label

The Power Generation block includes the complex switching that enables either of the two battery chargers to connect with any of the three battery components. As seen in Table 7 above, several of the sensor types are unable to detect any fault modes in this block. As mentioned earlier, the reason for this lies in the fact that many of the sensors are load specific and do not measure any components in the Power Generation side of the model. The Ambiguity Group Size of 102 for these tests is one more than the number of failure sources because the Ambiguity Group includes all failure sources and one additional state. In TEAMS, this state corresponds to “All Systems Go” and denotes the condition wherein there exist no faults in the system.

In the Power Generation block analysis, the Percentage Fault Isolation is one of the lowest among any of the other top-level component blocks. Closer examination of the ambiguity groups reveals that one set of switches that connects the chargers to the batteries has no test that can isolate between the three failed closed states of each switch. The ambiguity group for relay EY206 for instance, includes the following failure modes: ESH206A_Sensor_Closed, EY206_Coil_closed, and EY206_Contact_Closed. A similar situation exists for relay EY306. The Power Generation block contains no voltage or current sensors, and the testability numbers these tests provide are from sensors downstream of the battery chargers. An additional voltage sensor within this block would help to increase the fault isolation ability of the system by breaking up these ambiguity groups.

Other ambiguity groups that could similarly be broken up by the addition of voltage sensors exist in the Contact_Closed fault mode for the set of switches EY115, EY215, EY315, EY116, EY216, EY316, EY117, EY217, and EY317. There is currently no downstream test to distinguish between any three of the switches connected to one battery bus. A voltage sensor would need to be added immediately after each of these relays in order to increase isolation rate.

Test Label	All	Crew Observed	Panel Meters	Current Sensors	Voltage Sensors	Frequency Sensors	Flow Sensors	Temp. Sensors	CB Position Sensors	Relay Position Sensors	Light Meters
Percentage Fault Detection	100.00%	51.43%	0.00%	22.86%	22.86%	25.71%	25.71%	40.00%	0.00%	0.00%	28.57%
Percentage Fault Isolation	100.00%	42.25%	0.00%	22.54%	22.54%	2.82%	2.82%	5.63%	0.00%	0.00%	0.00%
Ambiguity Group Size	1	17.86	71	42.78	42.78	40.5	40.5	26.93	71	71	37.99
Number of failure sources	70	70	70	70	70	70	70	70	70	70	70
Number of tests	281	32	7	42	64	6	4	20	28	76	2
Number of tests not used	239	16	7	38	60	2	0	12	28	76	0

Table 8: ADAPT Loads component, testability analysis results by test label

Looking at testability metrics for the Loads component in Table 8, the main point of note is that 100% of the faults at the load level are both detectable and isolatable while using only 42 of the available tests. There are two main reasons for this. First of all, the physical loads are heavily sensed with an array of different sensor types. The light bank attached to AC Load A1, for example, uses both a light sensor and

individual temperature sensors for each bulb. A subset of these sensors can help distinguish between a complete failure of the light bank and a partial failure involving only one or two of the light bulbs. Second, there are a number of crew-observed tests that can tell whether a load is on or off through visual observation. The user can often get a good indication of how the system is running by monitoring the loads, so this is an ideal place for such tests. The effect of removing these crew observations as test points is discussed briefly below. A final reason for the high testability percentages is the relatively low number of failure sources compared to the other top-level modules.

The Loads block contains no relays or circuit breakers; all switching is performed at the Power Distribution block. Another interesting fact that was discovered through the use of the testability analysis is that the load sensors (flow, temperature, frequency, and light sensors) are good at fault detection, but they provide only a small percentage of the fault isolation. The crew-observed tests provided the most in terms of both fault detection and isolation.

Unfortunately, the fact that manual crew-observed tests play such an important role in Loads testability means that most automated diagnostic reasoners would be unable to reach such a high percentage of detection or isolation without at least some input from the user. Not all reasoners allow for this input, and on flight hardware some failure situations must be resolved more quickly than is possible with human feedback. As expected, there was a fairly substantial drop in testability when the same analysis was run without the benefit of crew-observed tests – total Percentage Fault Detection fell to 88.57% (-11.43%) while total Percentage Fault Isolation fell to 70.42% (-29.58%) for the Loads component.

9. Conclusion

Several result sets from the ADAPT TEAMS testability analysis are presented here, covering the testbed as a whole and also broken down by functional blocks. From these results, the primary conclusions from the testability analysis study can be summarized as follows: First, the voltage sensors, current sensors, and relay sensors are the most effective in terms of fault isolation and fault detection, though they are also the most numerous among the sensor groups. Second, by combining tests from various types of sensors, some of the testing that would otherwise be necessary can be eliminated. The most effective sensor groups for eliminating extra tests are circuit breaker position sensors, relay sensors, and current sensors. Unfortunately, these gains are diminished when using a subset of available system modes. It was also found that none of the existing sensors could be removed without at least some loss in testability. Third, a number of locations in the testbed were identified where the fault detection or isolation could be increased by making system changes or by adding additional sensors. Switching the power source to a single 24-volt battery or adding additional voltage sensors to the power generation section of the testbed are two of these examples. Finally, the crew-observed tests play a larger role in testability than originally predicted, especially when diagnosing faults in the Loads section of the ADAPT testbed. This would seem to stress the importance of human observations in conjunction with automated diagnosis when doing fault detection and isolation.

10. References

- [1] Poll, S., Patterson-Hine, A., Camisa, J., Garcia, D., Hall, D., Lee, C., Mengshoel, O., Neukom, C., Nishikawa, D., Ossenfort, J., Sweet, A., Yentus, S., Roychoudhury, I., Daigle, M., Biswas, G., & Koutsoukos, X. (2007 May). *Advanced Diagnostics and Prognostics Testbed*, 18th International Workshop on Principles of Diagnosis, Nashville, TN.
- [2] Ghoshal, S., Azam, M. & Malepati, V. (2006 October). *SBIR Phase III: Comprehensive Fault Detection, Isolation and Recovery (FDIR) on the ADAPTS Test Bed*. Qualtech Systems Inc., contract number NNA06AA51Z.
- [3] Fijany, A. & Vatan, F. (2006 March). *A New Efficient Algorithm for Analyzing and Optimizing the System of Sensors*, Proceedings of 2006 IEEE Aerospace Conference, Big Sky, MN.
- [4] Tumer, I. (2005 November). *Design Methods and Practices for Fault Prevention and Management in Spacecraft*, ISHEM Forum 2005, Napa, CA.
- [5] Deb, S., Pattipati, K.R., Raghavan, V., Shakeri, M., Shrestha, R. (1995 May). *Multi-Signal Flow Graphs: A Novel Approach for System Testability Analysis and Fault Diagnosis*, IEEE Aerospace and Electronic Systems Magazine, Volume 10, Issue 5.

REPORT DOCUMENTATION PAGE

Form Approved
OMB No. 0704-0188

The public reporting burden for this collection of information is estimated to average 1 hour per response, including the time for reviewing instructions, searching existing data sources, gathering and maintaining the data needed, and completing and reviewing the collection of information. Send comments regarding this burden estimate or any other aspect of this collection of information, including suggestions for reducing this burden, to Department of Defense, Washington Headquarters Services, Directorate for Information Operations and Reports (0704-0188), 1215 Jefferson Davis Highway, Suite 1204, Arlington, VA 22202-4302. Respondents should be aware that notwithstanding any other provision of law, no person shall be subject to any penalty for failing to comply with a collection of information if it does not display a currently valid OMB control number.

PLEASE DO NOT RETURN YOUR FORM TO THE ABOVE ADDRESS.

1. REPORT DATE (DD-MM-YYYY) 18-01-2008		2. REPORT TYPE NASA STI Technical Memorandum		3. DATES COVERED (From - To) Oct 2006 - Sept 2007	
4. TITLE AND SUBTITLE Advanced Diagnostic and Prognostic Testbed (ADAPT) Testability Analysis Report				5a. CONTRACT NUMBER	
				5b. GRANT NUMBER	
				5c. PROGRAM ELEMENT NUMBER ARMD/AVSP/IVHM 645846.02.07.01.01	
6. AUTHOR(S) John Ossenfort				5d. PROJECT NUMBER	
				5e. TASK NUMBER	
				5f. WORK UNIT NUMBER	
7. PERFORMING ORGANIZATION NAME(S) AND ADDRESS(ES) NASA Ames Research Center, Intelligent Systems Division Moffett Field, CA 94035-1000				8. PERFORMING ORGANIZATION REPORT NUMBER NASA/TM-2008-214569	
9. SPONSORING/MONITORING AGENCY NAME(S) AND ADDRESS(ES) National Aeronautics and Space Administration Washington, DC 20546-0001				10. SPONSORING/MONITOR'S ACRONYM(S) NASA	
				11. SPONSORING/MONITORING REPORT NUMBER NASA/TM-2008-214569	
12. DISTRIBUTION/AVAILABILITY STATEMENT Unclassified -- Unlimited Subject Category: 18 Distribution: Standard Availability: NASA CASI (301) 621-0390					
13. SUPPLEMENTARY NOTES					
14. ABSTRACT The placement of sensors and test points for the purpose of fault detection and isolation is an important consideration when designing any new system. A number of software tools have been developed to assist the system designer in proper placement of sensors during the design phase of a project. One important function of this software is a testability analysis of the system – essentially an evaluation of how “observable” the system behavior is using available tests. During the design phase, testability metrics from this analysis can help guide the designer in improving the inherent testability of the design. The purpose of this paper is to present the final testability results of the Advanced Diagnostic and Prognostic Testbed (ADAPT) after the system model was completed. The tool chosen to build the model and to perform the testability analysis with is the Testability Engineering and Maintenance System Designer (TEAMS-Designer).					
15. SUBJECT TERMS testability analysis, electrical power system health management, integrated vehicle health management, TEAMS, TEAMS-RT					
16. SECURITY CLASSIFICATION OF:			17. LIMITATION OF ABSTRACT	18. NUMBER OF PAGES	19a. NAME OF RESPONSIBLE PERSON
a. REPORT	b. ABSTRACT	c. THIS PAGE			19b. TELEPHONE NUMBER (Include area code)
U	U	U	UU	21	