



US007264200B2

(12) **United States Patent**
Bussom et al.

(10) **Patent No.:** **US 7,264,200 B2**
(45) **Date of Patent:** **Sep. 4, 2007**

(54) **SYSTEM AND METHOD FOR IMPROVED ROTOR TIP PERFORMANCE**

5,988,563 A 11/1999 Allen
6,227,487 B1 5/2001 Clark
6,345,790 B1 2/2002 Brix
6,394,397 B1 5/2002 Ngo et al.

(75) Inventors: **Richard Bussom**, West Chester, PA (US); **Michael A. McVeigh**, Media, PA (US); **Robert P. Narducci**, Glen Mills, PA (US); **Thomas A. Zientek**, Drexel Hill, PA (US)

(Continued)

FOREIGN PATENT DOCUMENTS

(73) Assignee: **The Boeing Company**, Chicago, IL (US)

EP 1127786 A1 8/2001

(Continued)

(*) Notice: Subject to any disclaimer, the term of this patent is extended or adjusted under 35 U.S.C. 154(b) by 207 days.

OTHER PUBLICATIONS

Gregory P. Haeffele, "An Investigation of Rotor Tip-Vortex Drag Reduction Using Tip Vanes" Department of Aerospace Engineering Georgia Institute of Technology, Apr. 23-24, 1981 Orlando, Florida pp. 1-28.

(21) Appl. No.: **10/898,698**

(Continued)

(22) Filed: **Jul. 23, 2004**

Primary Examiner—Timothy D. Collins

(65) **Prior Publication Data**

(74) Attorney, Agent, or Firm—Lee & Hayes, PLLC

US 2006/0027703 A1 Feb. 9, 2006

(57) **ABSTRACT**

(51) **Int. Cl.**
B64C 27/72 (2006.01)

The present invention discloses systems and methods for the performance enhancement of rotary wing aircraft through reduced torque, noise and vibration. In one embodiment, a system includes a sail having an aerodynamic shape positioned proximate to a tip of the rotor blade. An actuator may be configured to rotate the sail relative to the blade tip. A control system receives information from a rotorcraft system and commands the actuator to rotate the sail to a predetermined favorable rotor blade operating condition. In another embodiment, a method includes configuring the rotorcraft in a selected flight condition, communicating input signals to a control system operable to position sails coupled to tips of blades of a rotor assembly, processing the input signals according to a constraint condition to generate sail positional information, and transferring the sail positional information to the sail.

(52) **U.S. Cl.** **244/17.25; 416/24**

(58) **Field of Classification Search** 244/17.13, 244/17.25, 17.11; 416/210 R, 24, 238, 89, 416/210 A, 87

See application file for complete search history.

(56) **References Cited**

U.S. PATENT DOCUMENTS

- 4,172,574 A 10/1979 Spillman
- 4,247,063 A 1/1981 Jenkins
- 4,272,043 A 6/1981 Spillman
- 4,595,160 A 6/1986 Santos
- 4,671,473 A 6/1987 Goodson
- 4,722,499 A * 2/1988 Klug 244/199.4
- 5,275,358 A 1/1994 Goldhammer et al.
- 5,823,480 A 10/1998 La Roche

25 Claims, 6 Drawing Sheets

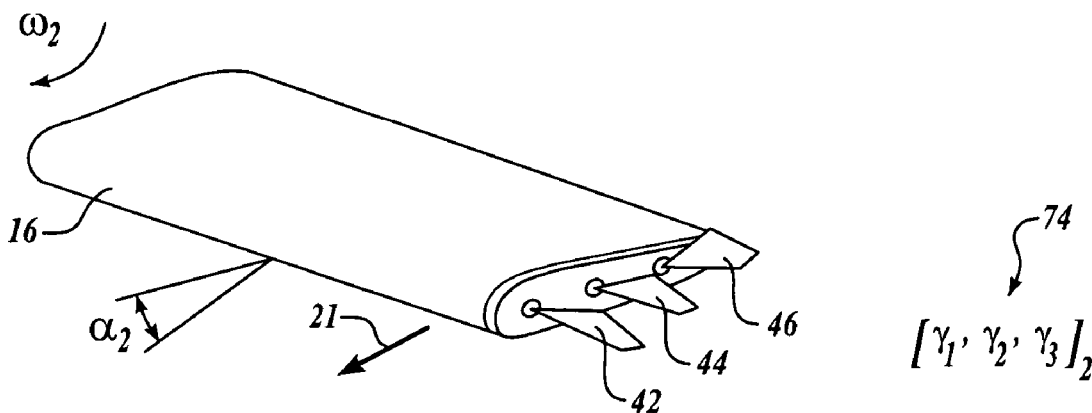

U.S. PATENT DOCUMENTS

6,431,499 B1 8/2002 La Roche et al.
6,467,732 B2* 10/2002 Tsukahara et al. 244/199.4
6,545,384 B1 4/2003 Pelrine et al.
2002/0066831 A1 6/2002 Ngo et al.

FOREIGN PATENT DOCUMENTS

EP 1428752 A1 6/2004

OTHER PUBLICATIONS

Albert L. Patterson III, "An Investigation of Rotor Blade Tip Shapes and Their Effects on Thrust and Torque" School of Aerospace Engineering Georgia Institute of Technology, Sep. 3, 1981, Atlanta, Georgia pp. 1-17.

T.M. Boyd, Jr. "The Effect of Blade Tip Vanes of Helicopter Rotor Performance" Aeronautical Systems Division, Wright-Patterson Air Force Base, Ohio Aug. 19, 1983 pp. 1-4.

Jarvis et al. "Investigation of Aerodynamic Improvements Using Wing Tip Sails" 37th AIAA Aerospace Sciences Meeting and Exhibit, Jan. 11-14, 1999 / Reno, NV pp. 1-12.

Zientek et al. "Rotorcraft Noise Reduction and Performance Enhancement" Rotorcraft Industrial Technology Association (RITA) BVWT0433 V-22 Segmented Blade Test 2002 pp. 1-26.

PCT Search Report and Written Opinion for Application No. PCT/US2005/026302, dated Aug. 16, 2006, 14 pages.

* cited by examiner

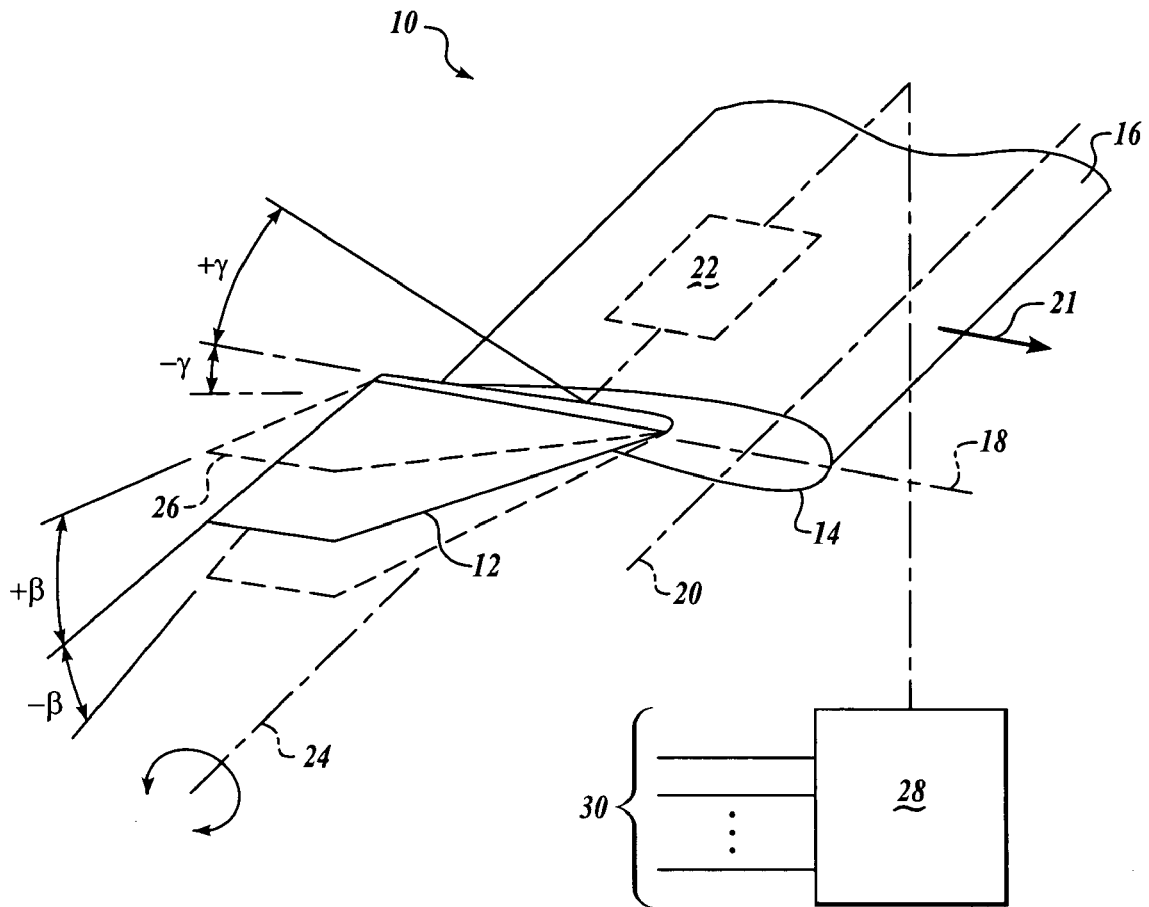

FIG. 1

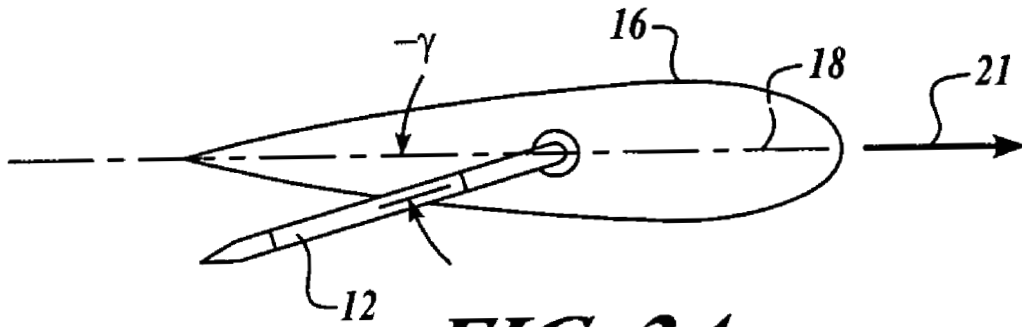

FIG. 2A

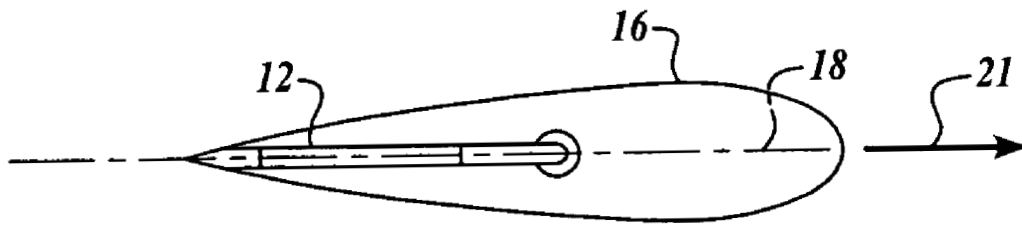

FIG. 2B

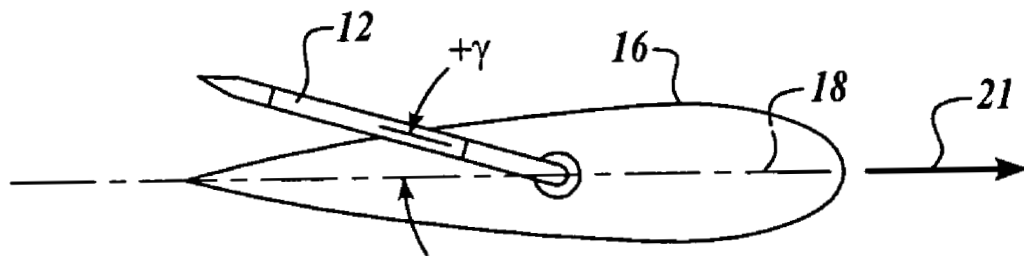

FIG. 2C

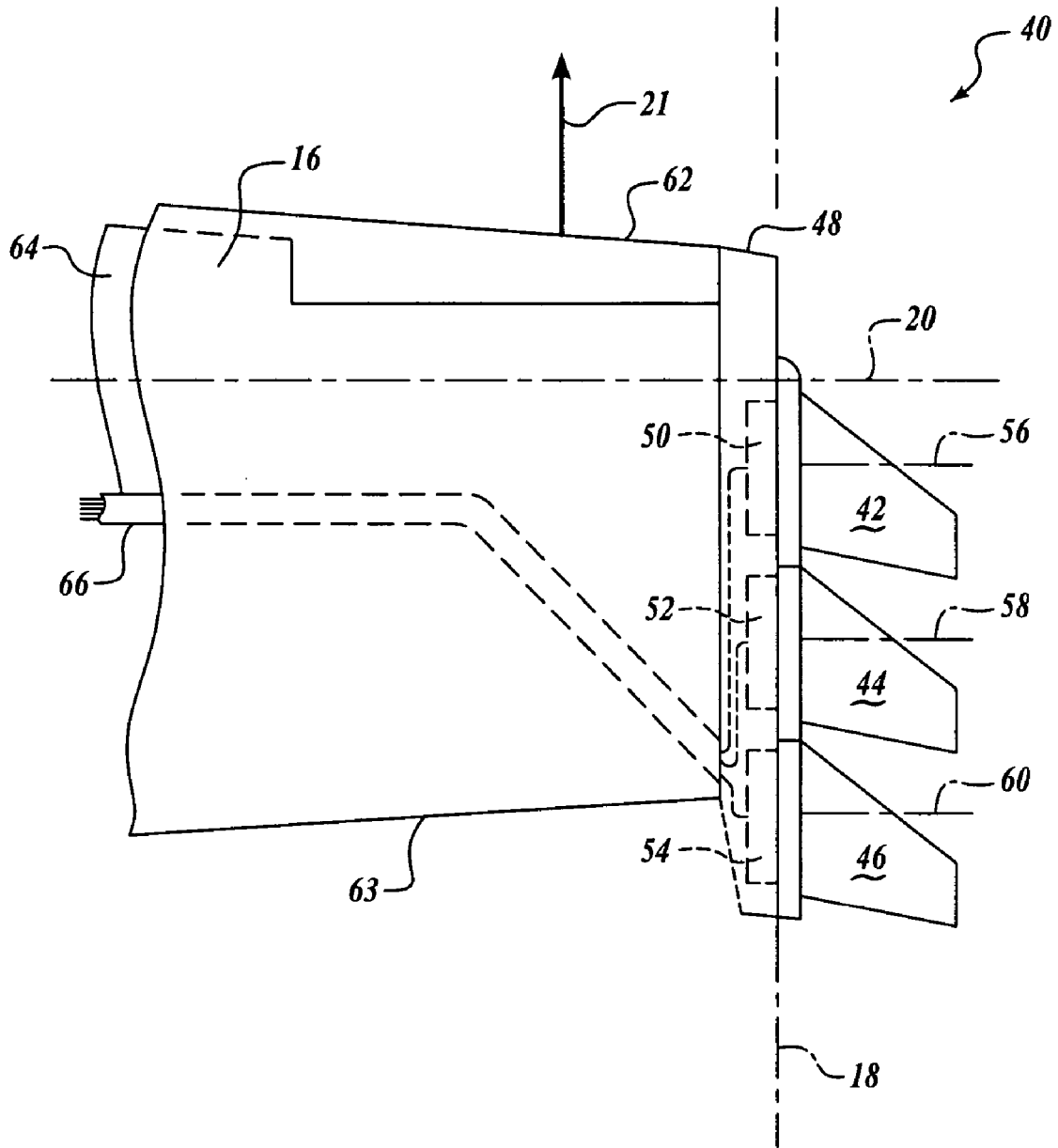

FIG. 3

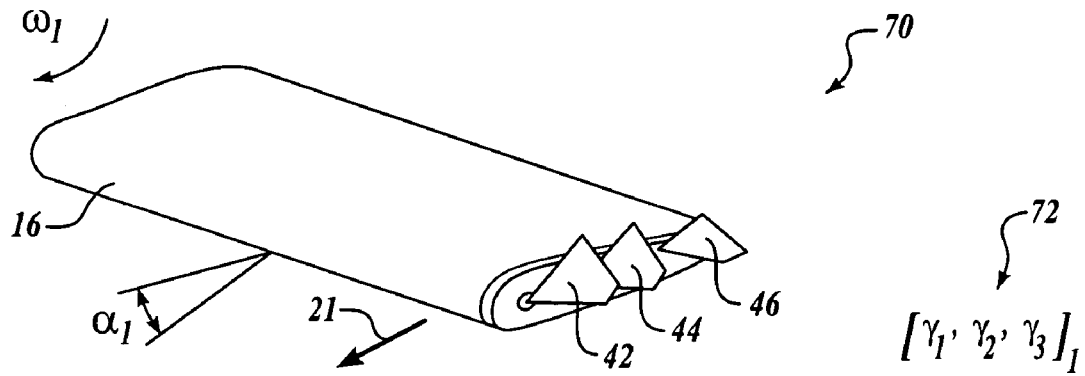

FIG. 4A

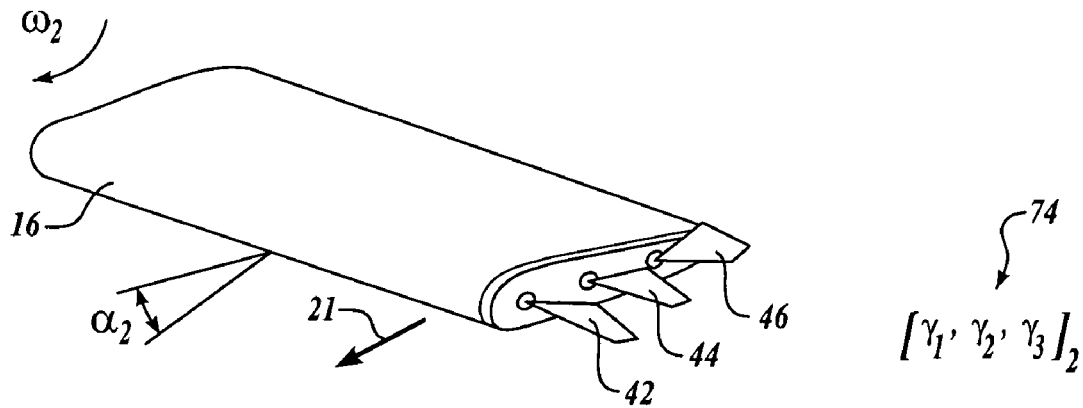

FIG. 4B

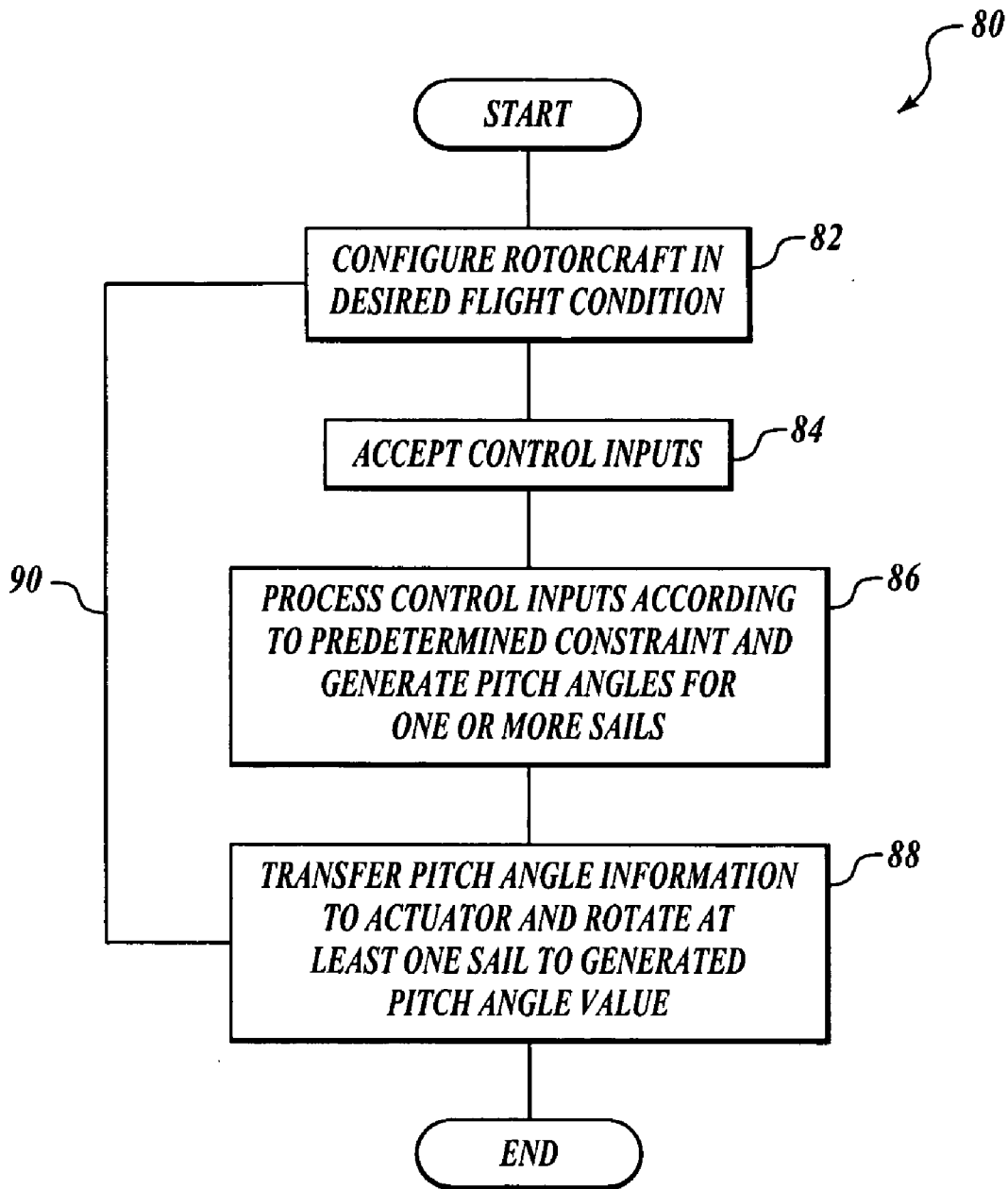

FIG. 5

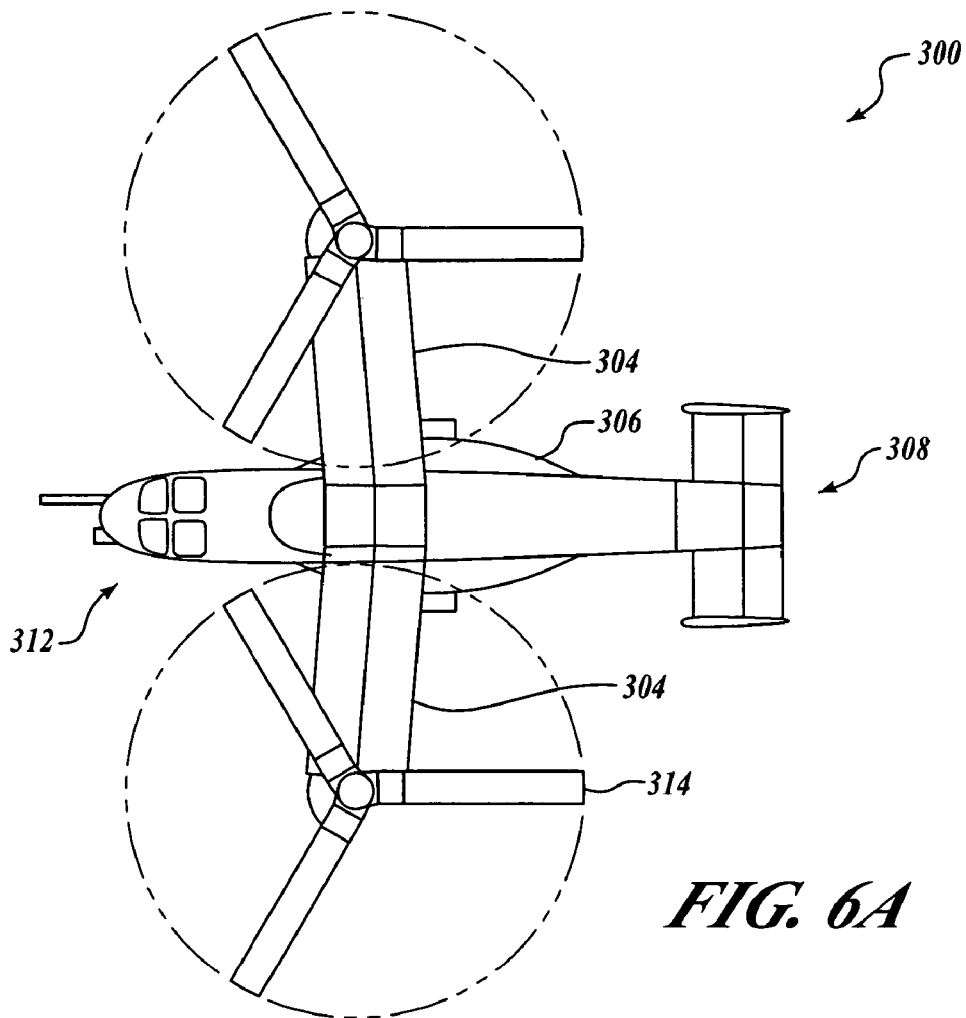

FIG. 6A

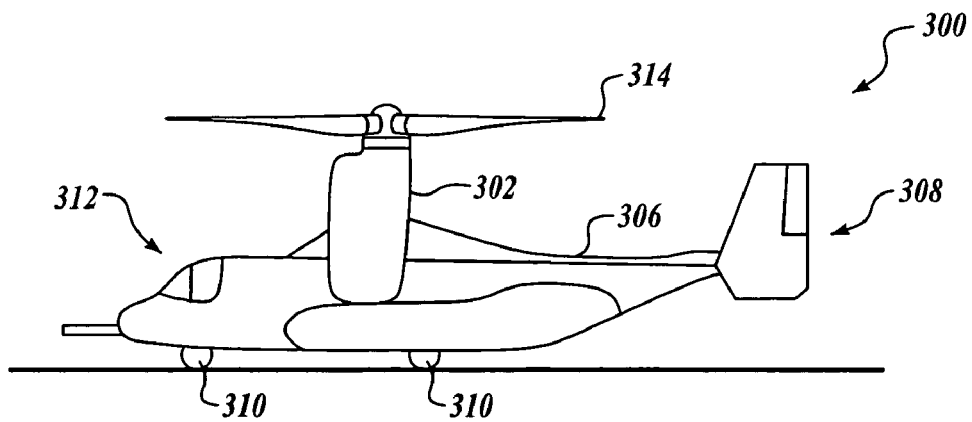

FIG. 6B

1

SYSTEM AND METHOD FOR IMPROVED ROTOR TIP PERFORMANCE

GOVERNMENT LICENSE RIGHTS

The invention described herein was made in the performance of work under NASA Contract No. NCC2-9019 and is subject to the provisions of Section 305 of the National Aeronautics and Space Act of 1958 (72 Stat. 435; 42 U.S.C. § 2457).

FIELD OF THE INVENTION

This invention relates generally to rotary wing aircraft, and more particularly to apparatus and methods for the performance enhancement of rotary wing aircraft.

BACKGROUND OF THE INVENTION

It is well known that rotary wing aircraft are capable of flight in a vertical direction as well as forwardly or backwardly in horizontal flight, and may further remain stationary while aloft. Examples of rotary wing aircraft correspondingly include helicopters and tilt-rotor aircraft, among others. In all of these flight vehicles, thrust is generated by one or more rotor assemblies having aerodynamically-shaped blades that are constantly in rotational motion relative to the flight vehicle. The generated thrust may be used to lift and/or propel the rotorcraft in a lateral direction. Due to pressure differences that exist between an upper surface of the blade and a lower surface while the blade is in motion, vortices are generated at the tips of the blades that produce various undesirable effects.

One notable effect is an increase in drag on the blades of the one or more rotor assemblies, particularly while the rotary wing aircraft is stationary, or hovering. Consequently, an engine that drives the one or more rotor assemblies must develop additional torque to overcome the pressure drag generated by the tip vortices, resulting in higher fuel consumption for the rotary wing aircraft. Further, since the tips of the blades generally operate at relatively high subsonic local Mach numbers (typically between $M=0.6$ to 0.95), an increase in compressibility drag may occur that is due to shock wave drag or shock-induced flow separation, particularly on an advancing blade tip when the vehicle is in forward motion.

Another undesirable effect of the tip vortices is the generation of noise and impulsive changes in aerodynamic loads on the blades. In particular, the interaction of vortices shed from a blade tip and a following blade, and/or the interaction of the tip vortices with the fuselage or empennage structures of the rotary wing aircraft, result in a phenomenon known as blade-vortex interaction (BVI), which may be particularly severe when the blades are relatively heavily loaded, such as during a low-speed descent to landing, or during the execution of certain flight maneuvers. Since BVI generates elevated vibration levels in various components comprising the rotary wing aircraft, the useful life of such components is typically shortened. Additionally, occupants in the rotary wing aircraft may experience the unpleasant effects of the elevated vibration levels generated by BVI.

Various prior art devices have been employed in an attempt to address the foregoing undesirable effects. For example, rotor blade tips have been configured with a sweep back angle, or with a localized span-wise twist. Still other prior art attempts have utilized improved airfoil cross-

2

sections for the rotor blade, or have employed tips having a negative dihedral angle. The foregoing devices are generally effective under a specific flight condition, and are relatively less effective under other different flight conditions.

Therefore, a need exists for improved apparatus and methods that mitigate the undesirable effects of tip vortices more effectively and over a greater range of flight conditions than achieved by the prior art.

SUMMARY OF THE INVENTION

The present invention comprises systems and methods for the performance enhancement of rotary wing aircraft. In one aspect, a system for improved rotor blade performance in a rotorcraft includes one or more sails having an aerodynamic shape and positioned proximate to a tip of the rotor blade. An actuator may be coupled to the sail that is configured to rotate the sail about a longitudinal axis of the sail, the longitudinal axis extending outwardly from the tip. A control system is operable to receive information from a selected rotorcraft system and to command the actuator to rotate the sail to a position that corresponds to a predetermined favorable rotor blade operating condition. In another aspect, the invention includes a method of operating a rotorcraft including configuring the rotorcraft in a selected flight condition, communicating input signals to a control system operable to position sails coupled to the tips of the blades of a rotor assembly, processing the input signals according to a constraint condition to generate sail positional information, and transferring the sail positional information to the sail.

BRIEF DESCRIPTION OF THE DRAWINGS

The preferred and alternative embodiments of the present invention are described in detail below with reference to the following drawings:

FIG. 1 is a block diagrammatic, partial isometric view of a system for improved rotor tip performance according to an embodiment of the invention;

FIGS. 2(a) through 2(c) are partial side views of the system of FIG. 1 that show the sail oriented at selected pitch angles;

FIG. 3 is a plan view a system for improved rotor tip performance according to another embodiment of the invention;

FIGS. 4(a) and 4(b) are partial isometric views of the system of FIG. 3 that is used to describe a method for configuring a rotor blade tip according to still another embodiment of the invention;

FIG. 5 is a flowchart illustrating a method of operating a rotorcraft, according to still yet another embodiment of the invention; and

FIG. 6 is a plan view and a side elevation view of a rotary wing aircraft having one or more of the disclosed embodiments of the present invention.

DETAILED DESCRIPTION OF THE INVENTION

The present invention relates to apparatus and methods for the performance enhancement of rotary wing aircraft. Many specific details of certain embodiments of the invention are set forth in the following description and in FIGS. 1 through 6 to provide a thorough understanding of such embodiments. One skilled in the art, however, will understand that the present invention may have additional

embodiments, or that the present invention may be practiced without several of the details described in the following description.

FIG. 1 is a block diagrammatic, partial isometric view of a system 10 for improved rotor tip performance according to an embodiment of the invention. The system 10 includes at least one sail 12 that is coupled to a tip portion 14 of a rotorcraft blade 16 along a chord 18 of the blade 16. The sail 12 is generally aerodynamically configured, which may include a sweep back angle relative to a longitudinal axis 20 of the blade 16. Additionally, the sail 12 may also be cambered, or have a twist imparted along a length of the sail 12. The sail 12 may also be coupled to the tip portion 14 so that the sail 12 is oriented at a positive dihedral angle Λ relative to the longitudinal axis 20. Alternately, the sail 12 may be oriented at a negative dihedral angle Λ , or may be positioned so that there is no dihedral angle between the sail 12 and the longitudinal axis 20. The sail 12 may be coupled to an actuator 22 positioned within the rotorcraft blade 16 that is operable to rotate the sail 12 about a sail rotation axis 24 to position the sail 12 at a predetermined pitch angle δ relative to the chord 18. With reference now to FIGS. 2(a) through 2(c), the sail 12 is shown oriented at a positive pitch angle δ , a neutral pitch angle δ , and a negative pitch angle δ relative to the chord 18. For clarity of illustration, the sail 12 as shown in FIGS. 2(a) through 2(c) does not have a dihedral angle Λ . It is understood, however, that the sail 12 may be oriented relative to the blade 16 so that a dihedral angle Λ is present. Further, although the sail 12 is shown in FIG. 2 rotating about an axis located at a mid-chord position of the blade 16, it is understood that the rotational axis may be located at any chord position on the blade 16.

Returning now to FIG. 1, the actuator 22 may be an electromagnetic device, such as an electric servomotor, or a conventional hydraulic or pneumatic actuator. In one particular embodiment, the actuator 22 is comprised of a "smart material" operable to adjustably move the sail 12 to a predetermined angular position while the blade 16 is moved in a direction 21. For example, the "smart material" may comprise a piezoelectric ceramic or polymer operable to rapidly change shape upon the application of an electric field. The "smart material" may also comprise an electrostrictive or magnetostrictive material that effects a change in shape upon the application of an electric or magnetic field to the material, respectively. Further, the "smart material" comprising the actuator 22 may be one of a thermoresponsive material, including shape memory alloys that exhibit pronounced changes in shape upon exposure to a thermal field. In one particular embodiment, the actuator 22 may be comprised of various electroactive polymers that exhibit changes in shape upon the application of an electric field. One example of an electroactive polymer material is disclosed in U.S. Pat. No. 6,545,384 to Pelrine, et al., which patent issued on Apr. 8, 2003 and is incorporated by reference. Suitable electroactive polymers are commercially available from SRI International, Inc. of Menlo Park, Calif., although other suitable alternatives exist.

Still referring to FIG. 1, the actuator 22 is coupled to a control system 28 that is operable to receive at least one input signal 30 from the rotorcraft and process the input signal 30 to generate an output positional signal that is communicated to the actuator 22. The control system 28 may be configured to process the input signal 30 in order to minimize an undesirable effect related to the rotorcraft blade 16. The at least one input signal 30 may comprise, for example, a signal obtained from a structural vibration detection system that employs accelerometers positioned on vari-

ous selected portions of the rotorcraft structure. Accordingly, the control system 28 generates an output positional signal that minimizes structural vibrations. The input signal 30 may also include, for example, signals obtained from a pitot-static system through an air-data computer, and the control system 28 may be configured to optimize the overall performance of the rotorcraft based upon the airspeed, altitude, or other pertinent flight data. Since the system 10 is expected to significantly enhance the propulsive efficiency of the rotor, thereby decreasing the torque required for a given thrust, the input signal 30 may be further obtained from a torque sensor coupled to the rotor, and the control system 28 may be configured to minimize the rotor torque for a selected flight condition. The control system 28 may also be coupled to other devices. For example, the actuator 22 may include a positional sensing portion (not shown in FIG. 1) that permits the angular position of the sail 12 to be transmitted to the control system 28 to confirm that the sail 12 has moved to the required pitch angle value.

FIG. 3 is a plan view of a system 40 for improved rotor tip performance according to another embodiment of the invention. In this embodiment, the system 40 includes a forward sail 42, an intermediate sail 44 and an aft sail 46 that are positioned adjacent to a rotor tip 48 and coupled to actuators 50, 52 and 54, respectively. The actuators 50, 52, 54 are configured to independently rotate the forward sail 42, the intermediate sail 44 and the aft sail 46 about the sail rotational axes 56, 58 and 60, respectively. For clarity of illustration, the forward sail 42, the intermediate sail 44 and the aft sail 46 are shown having a similar planform shape, span length and root chord length. It is understood, however, that the sails 42, 44 and 46 may have different planform shapes, span lengths, root chord lengths, or other geometrical variations well known to aeronautical designers, and may be further individually aerodynamically tailored to further optimize the system 40. For example, the forward sail 42, the intermediate sail 44 and the aft sail 46 may include a predetermined camber and/or twist along an axis of the sails 42, 44 and 46. Further, inclination of the forward sail 42, the intermediate sail 44 and the aft sail 46 is not shown in FIG. 3. It is nevertheless understood that the sails 42, 44 and 46 may be inclined relative to the longitudinal axis 20 so that each of the sails 42, 44 and 46 has a different dihedral angle Λ . Although the system 40 includes three sails, it is understood that, in other embodiments, fewer than three, or alternately, more than three sails may be present. Furthermore, it is understood that in still another particular embodiment, the one or more sails may not be coupled to actuators so that the sails are fixedly positioned on the rotor tip 48.

Still referring to FIG. 3, the forward sail 42, the intermediate sail 44 and the aft sail 46 are advantageously positioned adjacent to the rotor tip 48 at locations that are significantly aft of a leading edge 62 of the blade 16 so that one or more of the sails 42, 44 and 46 may extend beyond a trailing edge 63 of the rotorcraft blade 16 to take advantage of the more favorable air velocities from the tip vortex in that region. The rotor tip 48 is coupled to a flared spar assembly 64 that supports the rotor tip 48 on the blade 16. The flared spar assembly 64 may include an integral wire assembly 66 formed on or within the flared spar assembly 66 in order to fixedly support the wire assembly 66 when the blade 16 is in motion and experiencing high centrifugal forces, particularly near the rotor tip 48. The integral wire assembly 66 couples the forward actuator 50, the intermediate actuator 52 and the aft actuator 54 to the control system 28 (as shown in FIG. 1).

FIGS. 4(a) and 4(b) are partial isometric views of the system 40 of FIG. 3 that will be used to describe a method 70 for configuring a rotor blade tip according to another embodiment of the invention. In general, it is well known that different flight conditions typically encompass a different rotational velocity Ω of the rotorcraft blade 16 (as shown in FIG. 1) and a different angle of attack α for the blade 16. Accordingly, and referring now in particular to FIG. 4(a), the rotorcraft blade 16 is operated at a selected angle of attack α_1 and rotational rate Ω_1 corresponding to a selected first flight condition. Accordingly, the control system 28 (as shown in FIG. 1) accepts control inputs 30 (also shown in FIG. 1) and generates a first set of pitch angles 72 ($[\delta_1, \delta_2, \delta_3]_1$). The first set of pitch angles 72 may be selected by the control system 28 so that a vibrational level of the rotorcraft is minimized, or a rotor torque of the rotorcraft is minimized for the selected flight condition, or based upon other measured control inputs, as previously described. The first set of pitch angles 72 adjusts the forward sail 42, the intermediate sail 44 and the aft sail 46 as shown in FIG. 4(a), where the forward sail 42, the intermediate sail 44 and the aft sail 46 are each positioned at a different pitch angle. When the rotorcraft has transitioned to a second flight condition so that the rotorcraft blade 16 is operated at a different angle of attack α_2 and rotational rate Ω_2 , as shown in FIG. 4(b), a second set of pitch angles 74 ($[\delta_1, \delta_2, \delta_3]_2$) is generated by the control system 28. Accordingly, the pitch angle of the forward sail 42, the intermediate sail 44 and the aft sail 46 are changed to reflect the second selected flight condition. For example, in the embodiment shown in FIG. 4(b), the forward sail 42 and the intermediate sail 44 have a relatively small pitch angle, while the aft sail 46 has a relatively high pitch angle.

FIG. 5 is a flowchart illustrating a method 80 of operating a rotorcraft, according to still another embodiment of the invention. At block 82, the rotorcraft is configured in a desired flight condition. For example, the desired flight condition may include a hovering motion, or a maneuvering condition, or still other flight conditions that are well known. At block 84, the control system 28 (as shown in FIG. 1) receives control inputs 30 (also shown in FIG. 1). The control inputs 30 may be generated, for example, by a structural vibration detection system, by a torque measurement device coupled to the rotor, or by a pitot-static system, as previously described. Alternately, the control inputs may be obtained from other systems commonly installed in rotorcraft. At block 86, the control system 28 processes the control inputs 30 according to a constraint condition to generate pitch and/or dihedral angle information. The constraint condition may include minimizing structural vibration or minimizing acoustic emissions while the rotorcraft is configured in the desired flight condition. Alternately, the constraint condition may include reducing the rotor torque while maintaining the desired flight condition. At block 88, the pitch angle information generated at block 86 is transferred to the actuator 22 (as shown in FIG. 1) to move the sail 12 (again as shown in FIG. 1) to the pitch and/or dihedral angle value generated at block 86. The method 80 further includes either returning along a return path 90 to accept new control inputs at block 84, or terminating.

Those skilled in the art will also readily recognize that the foregoing embodiments may be incorporated into a wide variety of different systems. Referring now in particular to FIG. 6, a plan view and a side elevation view of a rotary wing aircraft 300 having one or more of the disclosed embodiments of the present invention is shown. With the exception of the embodiments according to the present

invention, the rotary wing aircraft 300 includes components and subsystems generally known in the pertinent art, and in the interest of brevity, will not be described in detail. As shown in FIG. 6, the rotary wing aircraft 300 generally includes one or more propulsion units 302 that may be coupled to wing assemblies 304, or alternately, to a fuselage 306 or even other portions of the rotary wing aircraft 300. Additionally, the rotary wing aircraft 300 also includes a tail assembly 308 and a landing assembly 310 coupled to the fuselage 306. The rotary wing aircraft 300 further includes other systems and subsystems generally required for the proper operation of the rotary wing aircraft 300. For example, the rotary wing aircraft 300 includes a flight control system 312 (not shown in FIG. 5), as well as a plurality of other electrical, mechanical and electromechanical systems that cooperatively perform a variety of tasks necessary for the operation of the rotary wing aircraft 300.

Although the rotary wing aircraft 300 shown in FIG. 6 is representative of a tilt-rotor aircraft, such as the V-22 tilt-rotor aircraft, jointly manufactured by The Boeing Company of Chicago, Ill. and Bell Helicopter Textron of Fort Worth, Tex., it is understood that the various embodiments of the present invention may also be incorporated into rotary wing aircraft that do not possess a tilt-rotor capability, such as a helicopter. Examples of such rotary wing aircraft are illustrated more fully in various descriptive volumes, such as Jane's All The World's Aircraft, available from Jane's Information Group, Ltd. of Coulsdon, Surrey, UK. The rotary wing aircraft 300 may include one or more of the embodiments of the system for improved rotor tip performance 314 according to the present invention, which may operate in association with the various systems and subsystems of the rotary wing aircraft 300. Although the foregoing discussion has described the various embodiments of the present invention as applied to a rotary wing aircraft, it is understood that the various embodiments may also be incorporated into other flight vehicles. For example, the various disclosed embodiments may be incorporated into a conventional propeller-driven fixed wing aircraft without significant modification.

While preferred and alternate embodiments of the invention have been illustrated and described, as noted above, many changes can be made without departing from the spirit and scope of the invention. Accordingly, the scope of the invention is not limited by the disclosure of these preferred and alternate embodiments. Instead, the invention should be determined entirely by reference to the claims that follow.

What is claimed is:

1. A system for improved rotor blade performance in a rotorcraft, comprising:

a plurality of sails, each sail having an aerodynamic shape and positioned proximate to a tip of the rotor blade;
an actuator coupled to each sail of the plurality of sails, the actuator being configured to rotate each sail about a longitudinal axis into a corresponding pitch angle independently of the other sails, such that one or more of the pitch angles has a different pitch value than the other pitch angles; and

a control system operable to receive information from a selected rotorcraft system and to command the actuator to actuate each sail to a position that corresponds to a predetermined favorable rotor blade operating condition.

2. The system of claim 1, wherein the longitudinal axis of the at least one sail forms a dihedral angle with a longitudinal axis of the blade.

7

3. The system of claim 2, wherein the dihedral angle is a positive dihedral angle or a negative dihedral angle.

4. The system of claim 1, wherein the actuator is further configured to adjust a corresponding dihedral angle of each sail independently of the other sails, such that one or more of the dihedral angles has a different dihedral value than the other dihedral angles.

5. The system of claim 1, wherein the actuator further comprises a piezoelectric material operable to effect the rotation of the at least one sail upon application of an electric field to the material.

6. The system of claim 1, wherein the actuator comprises a magnetostrictive material operable to effect the rotation of the at least one sail upon application of a magnetic field to the material.

7. The system of claim 1, wherein the at least one sail comprises a plurality of sails.

8. The system of claim 1, wherein the actuator comprises at least one of an electrostrictive material, a thermoresponsive material, and an electroactive polymer operable to effect the rotation of the at least one sail upon application of a thermal field to the material.

9. The system of claim 8, wherein the actuator comprises a thermoresponsive material that includes a shape memory alloy.

10. The system of claim 1, wherein the at least one sail projects at least partially aft of a trailing edge of the tip of the rotor blade.

11. The system of claim 1, wherein the control system is configured to receive information from a pitot-static system installed in the rotorcraft.

12. The system of claim 11, further comprising an air data computer coupled to the pitot-static system, and wherein the control system is configured to receive information from the air data computer.

13. A system for improved rotor blade performance in a rotorcraft, comprising:

at least one sail having an aerodynamic shape and positioned proximate to a tip of the rotor blade;

an actuator coupled to the at least one sail, the actuator being configured to rotate the sail about a longitudinal axis of the sail and to adjust a dihedral angle of the sail; and

a control system operable to receive information from a selected rotorcraft system and to command the actuator to actuate the sail to a position that corresponds to a predetermined favorable rotor blade operating condition, wherein the control system is configured to receive information from a structural vibration detection system operable to detect a vibration level on a selected portion of the rotorcraft structure.

14. A system for improved rotor blade performance in a rotorcraft, comprising:

at least one sail having an aerodynamic shape and positioned proximate to a tip of the rotor blade;

an actuator coupled to the at least one sail, the actuator being configured to rotate the sail about a longitudinal axis of the sail and to adjust a dihedral angle of the sail; and

a control system operable to receive information from a selected rotorcraft system and to command the actuator to actuate the sail to a position that corresponds to a predetermined favorable rotor blade operating condition, wherein the control system is configured to receive information from a torque sensor coupled to a rotor portion of the rotorcraft.

15. A rotary wing aircraft, comprising:

a rotor assembly having a plurality of blades attached thereto;

8

a propulsion system operatively coupled to the rotor assembly; and

a system for improved rotor blade performance in a rotorcraft, further comprising:

a plurality of sails, each sail coupled to tips of the blades and rotatable about a longitudinal axis that extends in a span-wise direction along the sail;

an actuator coupled to each sail of the plurality of sails and coupled to the blade tips and operable to rotate each sail about the longitudinal axis into a corresponding pitch angle independently of the other sails such that one or more of the pitch angles has a different pitch value than the other pitch angles; and

a control system coupled to a selected rotorcraft system and operable to receive information from the rotorcraft system and to controllably adjust the actuator to rotate each sail to a position that corresponds to a predetermined favorable rotor blade operating condition.

16. The system of claim 15, wherein the actuator being comprised of a smart material that is responsive to an applied field, the smart material including at least one of a piezoelectric material, and a magnetostrictive material, and wherein the applied field is at least one of an electric field and a magnetic field.

17. The system of claim 15, wherein the actuator is further configured to adjust a corresponding dihedral angle of each sail independently of the other sails, such that one or more of the dihedral angles has a different dihedral value than the other dihedral angles.

18. The system of claim 15, wherein the smart material comprises an electrostrictive material and the applied field is an electric field operable to effect the rotation of the at least one sail upon application of the electric field to the material.

19. The system of claim 15, wherein the smart material comprises a thermoresponsive material and the applied field is a thermal field operable to effect the rotation of the at least one sail upon application of the thermal field to the material.

20. The system of claim 19, wherein the thermoresponsive material comprises a memory shape alloy.

21. The system of claim 15, wherein the smart material comprises an electroactive polymer and the applied field is an electric field operable to effect the rotation of the at least one sail upon application of the electric field to the material.

22. The system of claim 15, wherein the control system is configured to receive information from a pitot-static system installed in the rotorcraft.

23. The system of claim 22, further comprising an air data computer coupled to the pitot-static system, and wherein the control system is configured to receive information from the air data computer.

24. A rotary wing aircraft, comprising:

a rotor assembly having a plurality of blades attached thereto;

a propulsion system operatively coupled to the rotor assembly; and

a system for improved rotor blade performance in a rotorcraft, further comprising:

at least one sail coupled to tips of the blades and rotatable about a longitudinal axis that extends in a span-wise direction along the sail;

an actuator coupled to the at least one sail and coupled to the blade tips and operable to rotate the sail about the longitudinal axis and adjust a dihedral angle of the at least one sail, the actuator being comprised of a smart material that is responsive to an applied field; and

a control system coupled to a selected rotorcraft system and operable to receive information from the rotorcraft system and to apply the field to the actuator to rotate the sail to a position that corresponds to a predetermined

9

favorable rotor blade operating condition, wherein the control system is configured to receive information from a structural vibration detection system operable to detect a vibration level on a selected portion of the rotorcraft structure.

25. A rotary wing aircraft, comprising:
- a rotor assembly having a plurality of blades attached thereto;
 - a propulsion system operatively coupled to the rotor assembly; and
 - a system for improved rotor blade performance in a rotorcraft, further comprising:
 - at least one sail coupled to tips of the blades and rotatable about a longitudinal axis that extends in a span-wise direction along the sail;

5

10

10

an actuator coupled to the at least one sail and coupled to the blade tips and operable to rotate the sail about the longitudinal axis and adjust a dihedral angle of the at least one sail, the actuator being comprised of a smart material that is responsive to an applied field; and

a control system coupled to a selected rotorcraft system and operable to receive information from the rotorcraft system and to apply the field to the actuator to rotate the sail to a position that corresponds to a predetermined favorable rotor blade operating condition, wherein the control system is configured to receive information from a torque sensor coupled to a rotor portion of the rotorcraft.

* * * * *