



US006387241B1

(12) **United States Patent**
Murphy et al.

(10) **Patent No.:** **US 6,387,241 B1**
 (45) **Date of Patent:** **May 14, 2002**

(54) **METHOD OF STERILIZATION USING OZONE**

(75) Inventors: **Oliver J. Murphy; G. Duncan Hitchens**, both of Bryan, TX (US)

(73) Assignee: **Lynntech, Inc.**, College Station, TX (US)

(*) Notice: Subject to any disclaimer, the term of this patent is extended or adjusted under 35 U.S.C. 154(b) by 0 days.

(21) Appl. No.: **09/426,387**

(22) Filed: **Oct. 25, 1999**

Related U.S. Application Data

(63) Continuation of application No. 08/910,598, filed on Jul. 31, 1997, now Pat. No. 5,972,196, which is a continuation-in-part of application No. 08/483,333, filed on Jul. 7, 1995, now abandoned, which is a continuation-in-part of application No. 08/091,752, filed on Jul. 13, 1993, now Pat. No. 5,460,705.

(51) **Int. Cl.**⁷ **C25C 1/00**
 (52) **U.S. Cl.** **205/626; 422/186.08**
 (58) **Field of Search** **205/626; 422/186.07, 422/186.08, 186.12**

(56) **References Cited**

U.S. PATENT DOCUMENTS

3,438,136 A	4/1969	Raymond
4,316,782 A	2/1982	Foller
4,375,395 A	3/1983	Foller
4,416,747 A	11/1983	Menth
4,417,969 A	11/1983	Ezzell
4,541,989 A	9/1985	Foller

4,549,477 A	10/1985	McCabe
4,759,849 A	7/1988	Baumann
4,792,407 A	12/1988	Zeff
4,793,932 A	12/1988	Ford
4,876,115 A	10/1989	Raistrick
4,933,411 A	6/1990	Gifford
5,011,699 A	4/1991	Mitsuda et al.

(List continued on next page.)

OTHER PUBLICATIONS

Pallav Tatpudi, Synthesis of Hydrogen Peroxide in a Proton Exchange . . . , Apr. 1993, J.Elect Soc. pp. L55-L57.
 Pallav Tatapudi, Simultaneous Synthesis of Ozone and Hydrogen Peroxide . . . , May 1994, J. Elect Soc. pp. 1174-1178.
 Pallav Tatapudi, Paired Synthesis of Ozone and Hydrogen Peroxide . . . , pp. 274-285, No Date Available.

(List continued on next page.)

Primary Examiner—Kathryn Gorgos
Assistant Examiner—Wesley A. Nicolas
 (74) *Attorney, Agent, or Firm*—Streets & Steele; Jeffrey L. Streets

(57) **ABSTRACT**

Methods of using ozone have been developed which sterilize instruments and medical wastes, oxidize, organics found in wastewater, clean laundry, break down contaminants in soil into a form more readily digested by microbes, kill microorganisms present in food products, and destroy toxins present in food products. The preferred methods for killing microorganism and destroying toxins use pressurized, humidified, and concentrated ozone produced by an electrochemical cell.

33 Claims, 10 Drawing Sheets

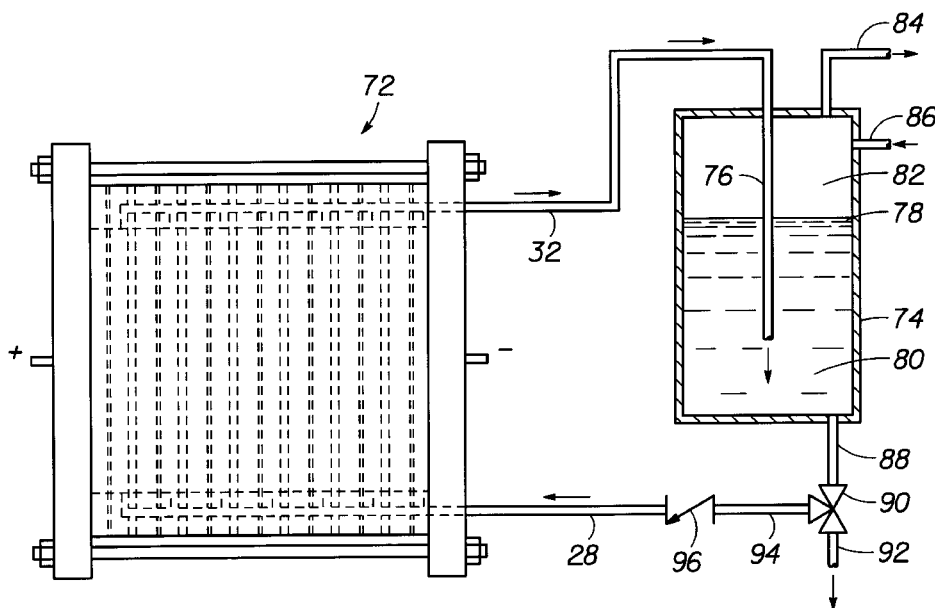

U.S. PATENT DOCUMENTS

5,069,880 A * 12/1991 Karlson 422/186.19
 5,087,419 A * 2/1992 Lutz 422/28
 5,097,556 A 3/1992 Engel
 5,114,549 A 5/1992 Shimamune
 5,120,512 A 6/1992 Masuda
 5,181,399 A 1/1993 Engel
 5,205,927 A 4/1993 Wickramanayake
 5,225,172 A 7/1993 Meyler et al.
 5,227,184 A 7/1993 Hurst
 5,242,764 A 9/1993 Dpar
 5,245,845 A 9/1993 Langford
 5,246,792 A 9/1993 Watanabe
 5,254,265 A 10/1993 Chung
 5,266,275 A 11/1993 Faddis
 5,269,943 A 12/1993 Wickramanayake
 5,277,868 A 1/1994 Langford
 5,290,406 A * 3/1994 Sawamoto et al. 205/626
 5,316,740 A 5/1994 Baker
 5,326,542 A 7/1994 Sizer
 5,328,706 A 7/1994 Endico
 5,334,355 A 8/1994 Faddis
 5,346,669 A 9/1994 Sweval
 5,348,662 A 9/1994 Yen
 5,385,711 A 1/1995 Baker
 5,403,602 A 4/1995 Endico
 5,409,616 A 4/1995 Garbutt

5,427,801 A 6/1995 Uehara
 5,431,939 A 7/1995 Cox
 5,433,920 A 7/1995 Sizer
 5,441,622 A 8/1995 Langford
 5,443,801 A 8/1995 Langford
 5,460,705 A 10/1995 Murphy
 5,468,454 A 11/1995 Kim
 5,520,888 A 5/1996 Berndt
 5,591,117 A 1/1997 Zelno
 5,824,274 A 10/1998 Long
 5,868,999 A 2/1999 Karlson
 6,006,387 A 12/1999 Cooper et al.
 6,066,348 A 5/2000 Yuan et al.

OTHER PUBLICATIONS

Pallav Tatapudi, Synthesis of Ozone in a Proton Exchange Membrane Electrochemical Reactor, Dec. 12, 1993 pp. 3527-3530. J. Electrochem. Soc.
 Masahiro Watanabe, Management of the Water Content in Polymer Electrolyte . . . , Nov. 1993 pp. 3190-3193.
 Tom D. Rodgers, Water Purification, Microbiological Control . . . , SAE TECH 921234, Jul. 1992.
 G. Duncan Hitchens, Development of a Proton-Exchange Membrane . . . , SAE TECH 911538, Jul. 1991 pp. 131-140.

* cited by examiner

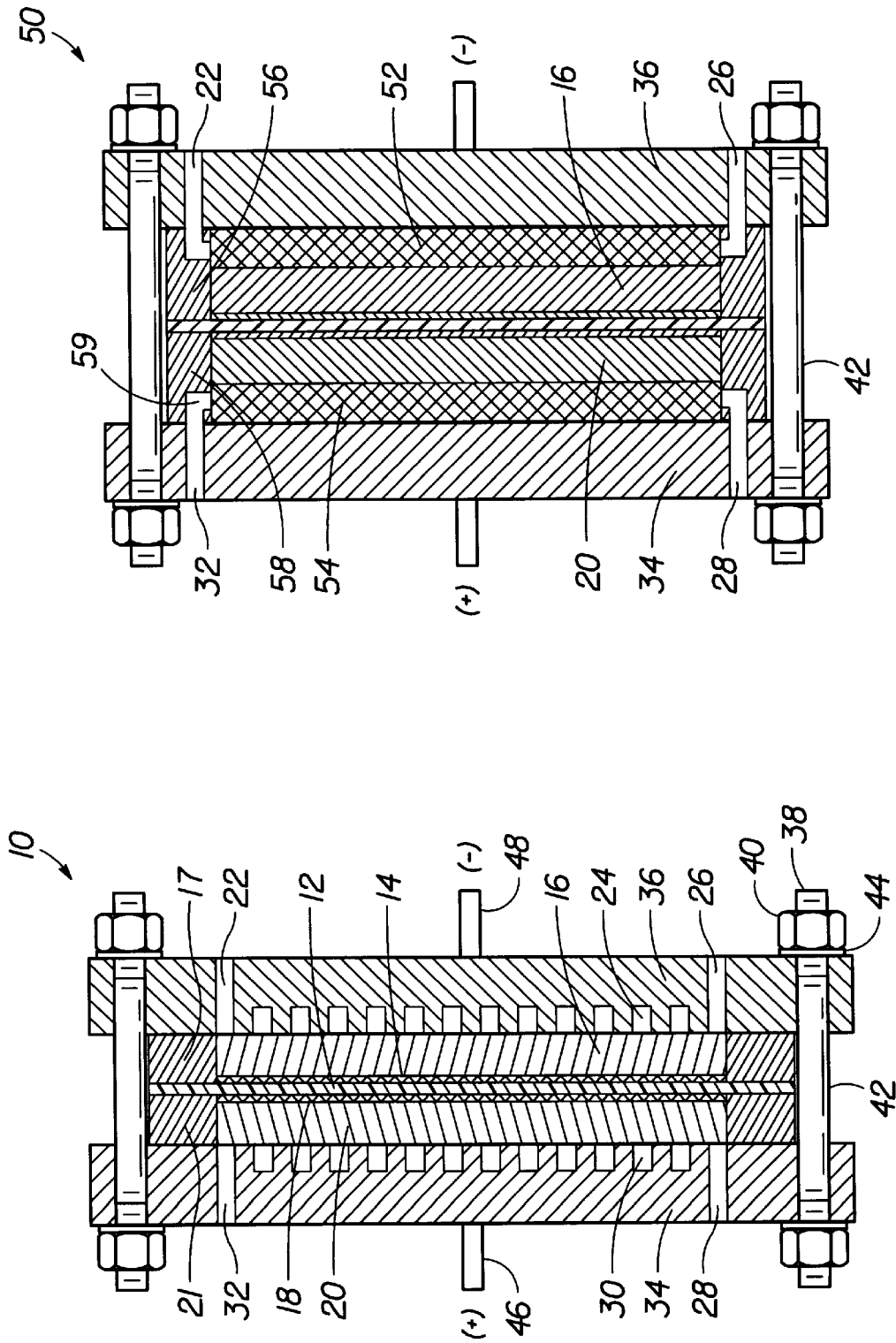

FIG. 2

FIG. 1

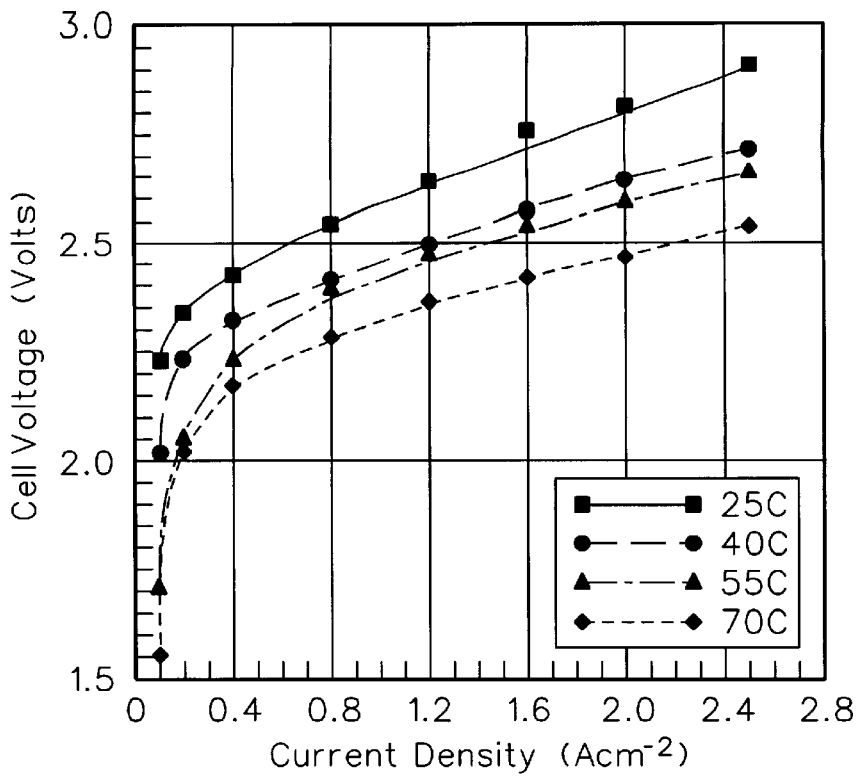

FIG. 3

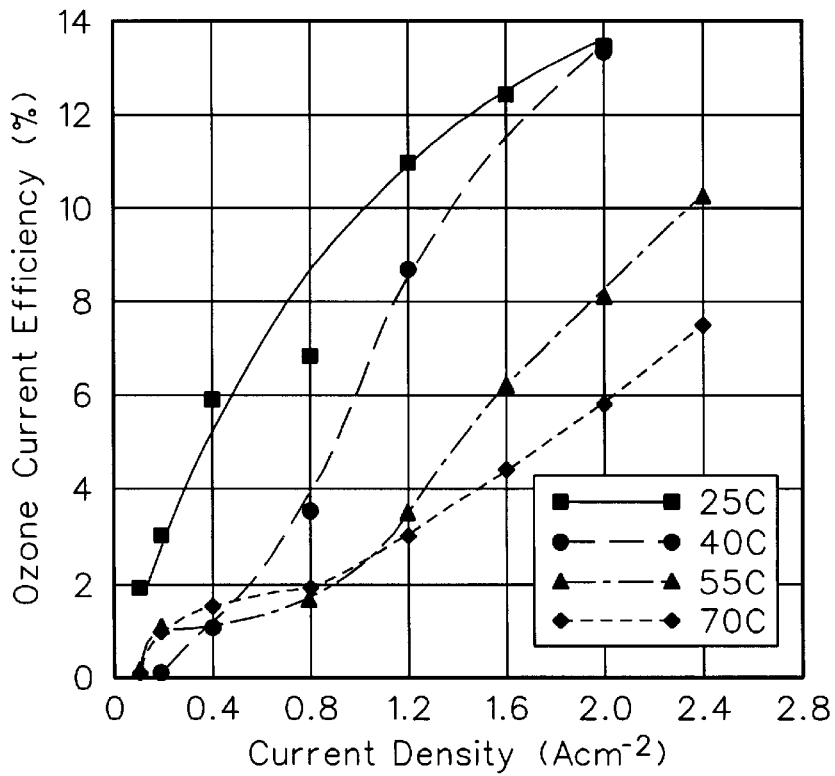

FIG. 4

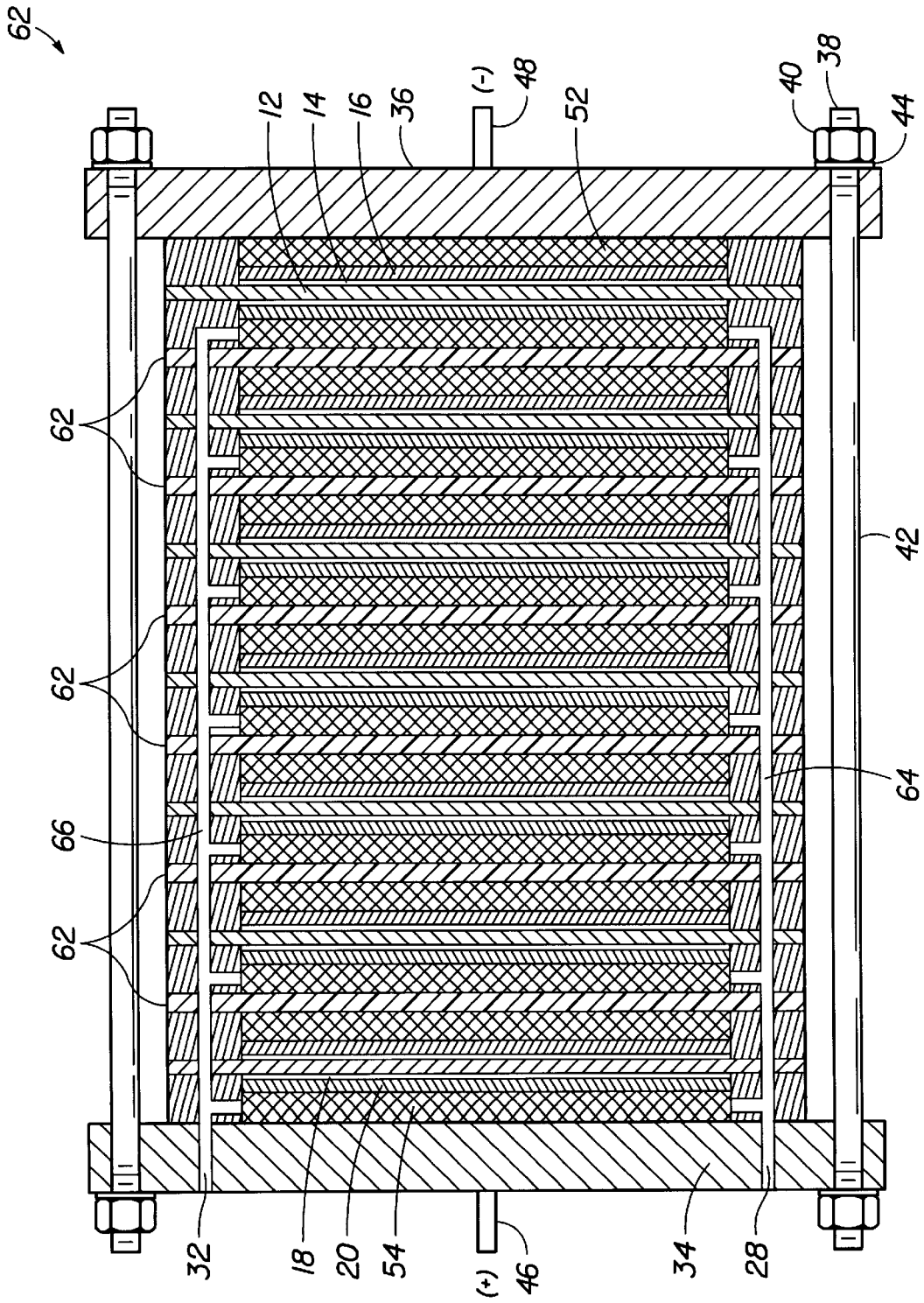

FIG. 5

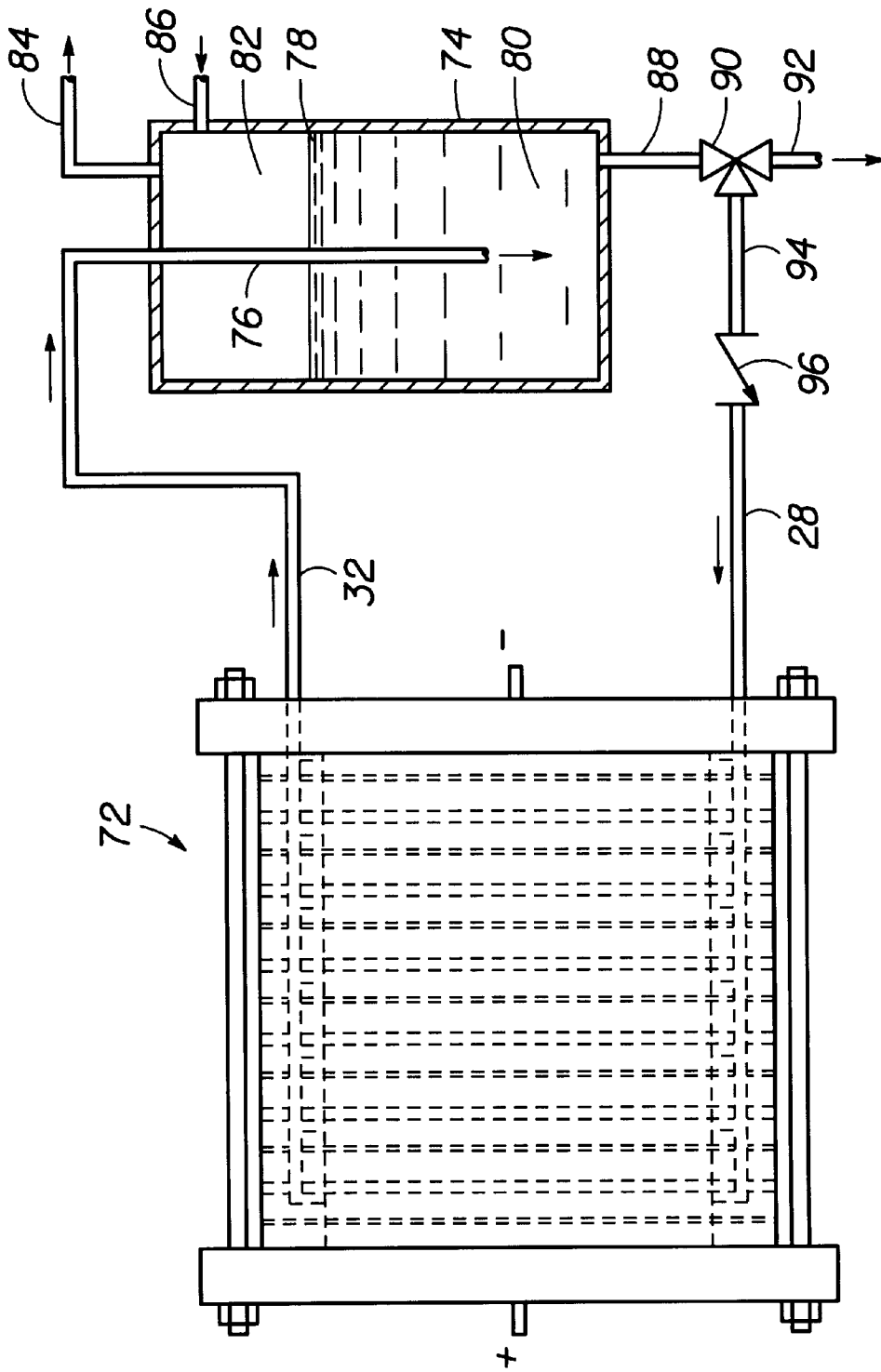

FIG. 6

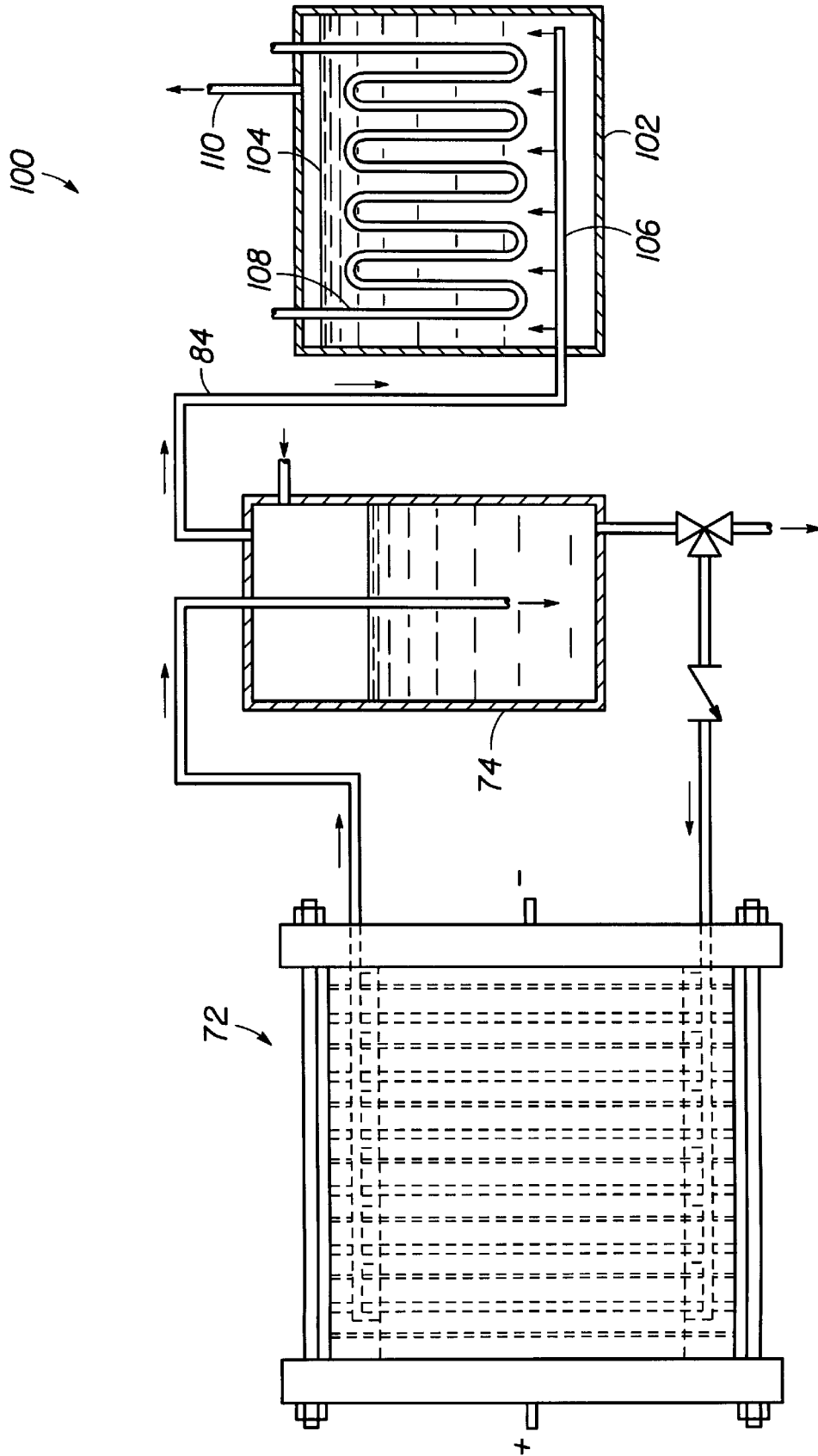

FIG. 7

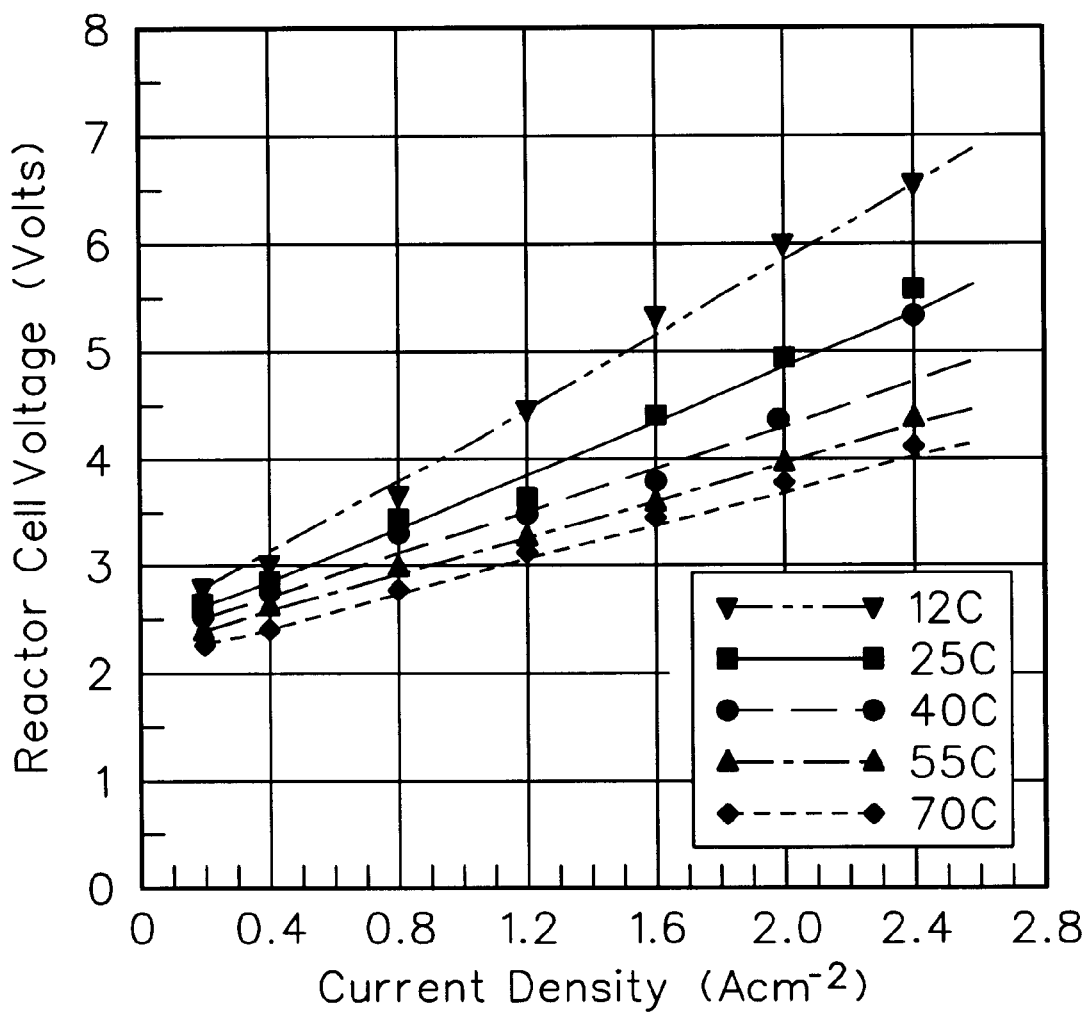

FIG. 8

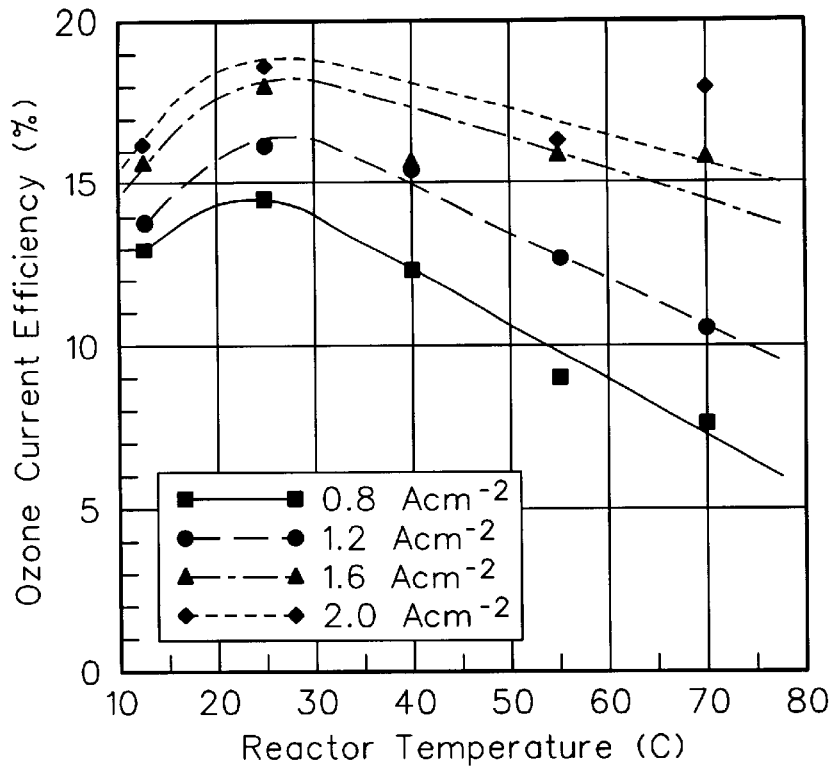

FIG. 9

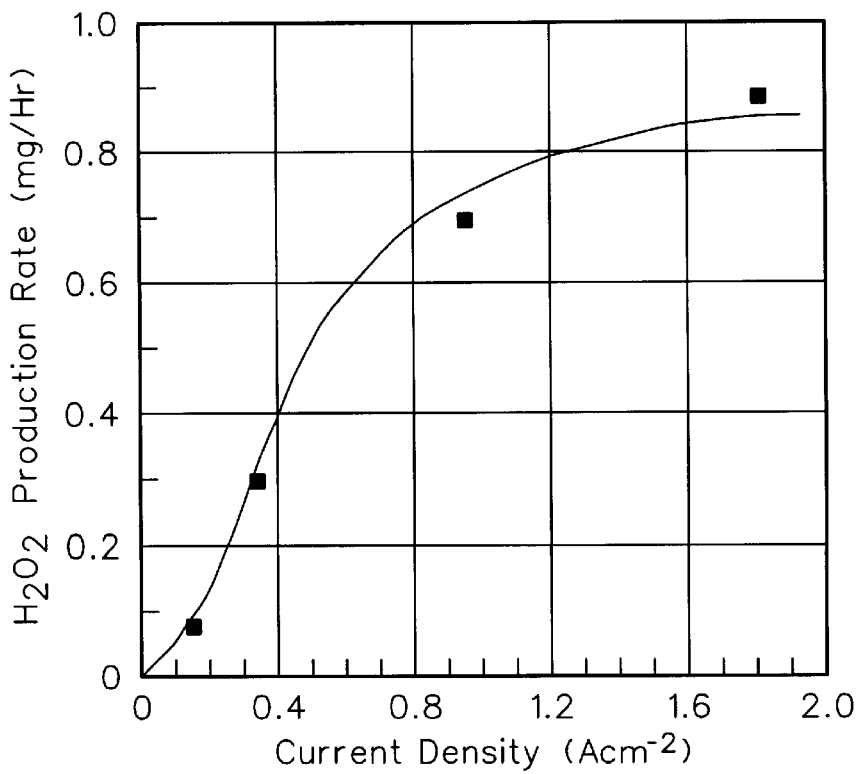

FIG. 10

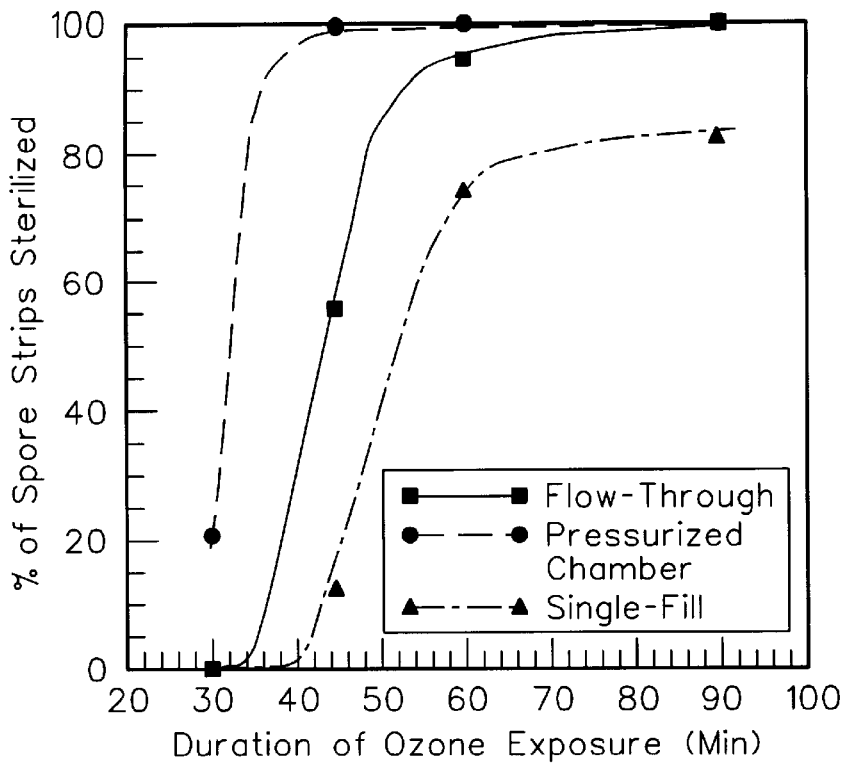

FIG. 11

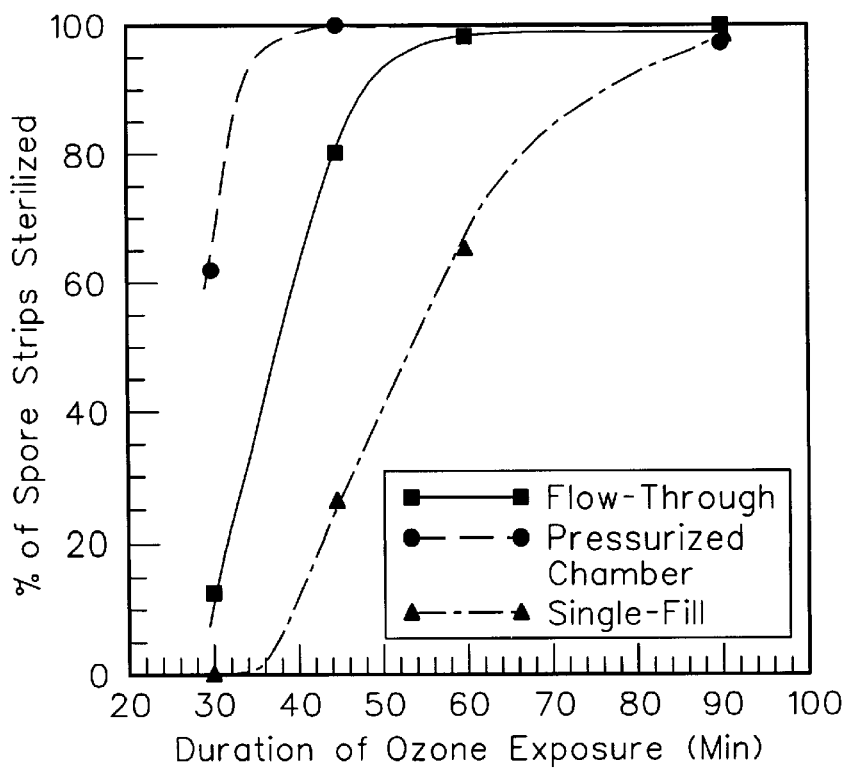

FIG. 12

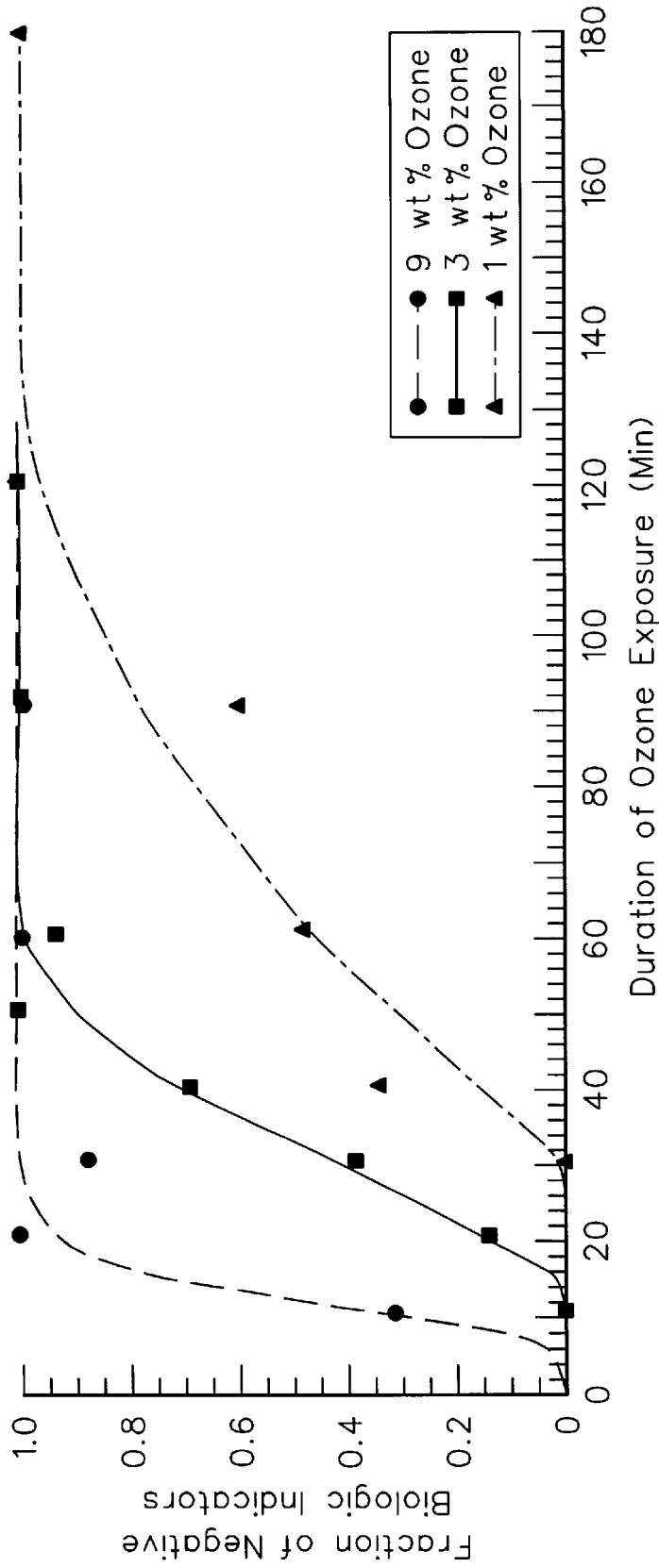

FIG. 13

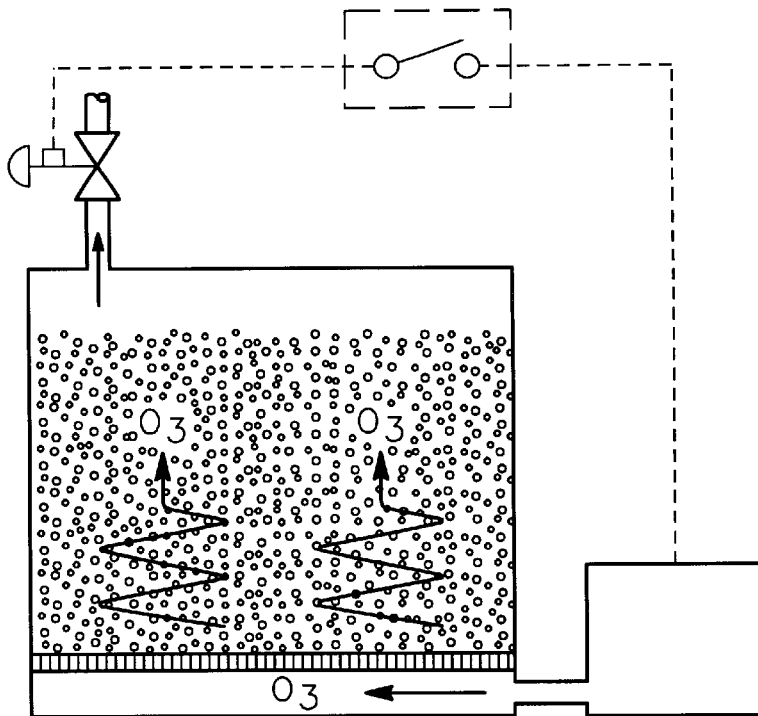

FIG. 14

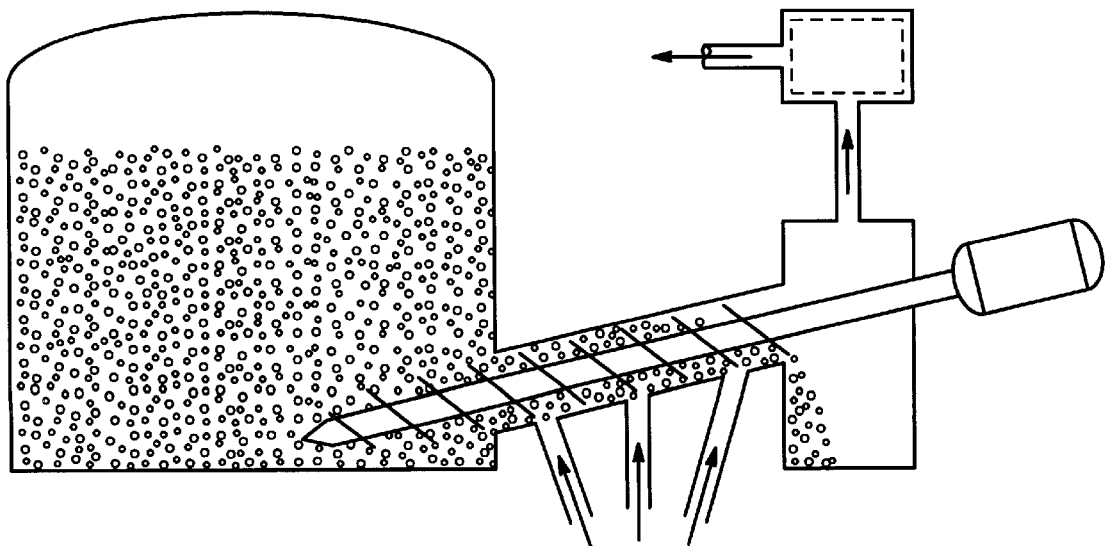

FIG. 15

METHOD OF STERILIZATION USING OZONE

This application is a continuation of U.S. patent application Ser. No. 08/910,598, filed Jul. 31, 1997, now U.S. Pat. No. 5,972,196, which is a continuation-in-part of U.S. patent application Ser. No. 08/483,333, filed Jul. 7, 1995, now abandoned, which is a continuation-in-part of U.S. patent application Ser. No. 08/091,752, filed Jul. 13, 1993, now U.S. Pat. No. 5,460,705.

This invention was made with Government support under the following contracts or grants: NAS9-18317 and NAS9-18505 awarded by NASA; 1 R43 AI29292-01 awarded by the National Institute of Allergy and Infectious Diseases; N000024-91-C4067 awarded by the Navy; and DMI-9461950 awarded by the National Science Foundation. The Government has certain rights in this invention.

BACKGROUND OF THE INVENTION

This invention relates generally to improvements in the production of ozone (O₃). More particularly, the invention relates to the electrolytic production of ozone utilizing a proton exchange membrane to separate the anode and depolarized cathode.

Ozone has long been recognized as a useful chemical commodity valued particularly for its outstanding oxidative activity. Because of this activity it finds wide application in disinfection processes. In fact, it kills bacteria more rapidly than chlorine, it decomposes organic molecules, and removes coloration in aqueous systems. Ozonation removes cyanides, phenols, iron, manganese, and detergents. It controls slime formation in aqueous systems, yet maintains a high oxygen content in the system. Unlike chlorination, which may leave undesirable chlorinated organic residues in organic containing systems, ozonation leaves fewer potentially harmful residues. There is evidence that ozone will destroy viruses. It is used for sterilization in the brewing industry and for odor control in sewage treatment and manufacturing. And ozone is employed as a raw material in the manufacture of certain organic compounds, e.g., oleic acid and peroxyacetic acid.

Thus, ozone has widespread application in many diverse activities, and its use would undoubtedly expand if its cost of production could be reduced. In addition, since ozone is explosive when concentrated as either a gas or liquid, or when dissolved into solvents or absorbed into gels, its transportation is potentially hazardous. Therefore, it is generally manufactured on the site where it is used. However, the cost of generating equipment, and poor energy efficiency of production has deterred its use in many applications and in many locations.

On a commercial basis, ozone is currently produced by the silent electric discharge process, otherwise known as corona discharge, wherein air or oxygen is passed through an intense, high frequency alternating current electric field. The corona discharge process forms ozone through the following reaction:

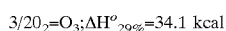

Yields in the corona discharge process generally are in the vicinity of 2% ozone, i.e., the exit gas may be about 2% O₃ by weight. Such O₃ concentrations, while quite poor, in an absolute sense, are still sufficiently high to furnish usable quantities of O₃ for the indicated commercial purposes. Another disadvantage of the corona process is the production of harmful NO_x, otherwise known as nitrogen oxides.

Other than the aforementioned electric discharge process, there is no other commercially exploited process for producing large quantities of O₃.

However, O₃ may also be produced by the electrolytic process, wherein an electric current (normally D.C.) is impressed across electrodes immersed in an electrolyte, i.e., electrically conducting, fluid. The electrolyte includes water, which, in the process, dissociates into its respective elemental species. O₂ and H₂. Under the proper conditions, the Oxygen is also evolved, as the O₃ species. The evolution of O₃ may be represented as:



It will be noted that the DH^o in the electrolytic process is many times greater than that for the electric discharge process. Thus, the electrolytic process appears to be at about a six-fold disadvantage.

More specifically, to compete on an energy cost basis with the electric discharge method, an electrolytic process must yield at least a six-fold increase in ozone. Heretofore, the necessary high yields have not been realized in any foreseeable practical electrolytic system.

The evolution of O₃ by electrolysis of various electrolytes has been known for well over 100 years. High yields up to 35% current efficiency have been noted in the literature. Current efficiency is a measure of ozone production relative to oxygen production for given inputs of electrical current, i.e., 35% current efficiency means that under the conditions stated, the O₂/O₃ gases evolved at the anode are comprised of 35% O₃ by volume. However, such yields could only be achieved utilizing very low electrolyte temperatures, e.g., in the range from about -30° C. to about -65° C. Maintaining the necessary low temperatures, obviously requires costly refrigeration equipment as well as the attendant additional energy cost of operation.

Ozone, O₃, is present in large quantities in the upper atmosphere in the earth to protect the earth from the sun's harmful ultraviolet rays. In addition, ozone has been used in various chemical processes, is known to be a strong oxidant, having an oxidation potential of 2.07 volts. This potential makes it the fourth strongest oxidizing chemical known.

Because ozone has such a strong oxidation potential, it has a very short half-life. For example, ozone which has been solubilized in waste water may decompose in a matter of 20 minutes. Ozone can decompose into secondary oxidants such as highly reactive hydroxyl (OH*) and peroxy (HO₂*) radicals. These radicals are among the most reactive oxidizing species known. They undergo fast, non selective, free radical reactions with dissolved compounds. Hydroxyl radicals have an oxidation potential of 2.8 volts (V), which is higher than most chemical oxidizing species including O₃. Most of the OH* radicals are produced in chain reactions where OH itself or HO₂* act as initiators.

Hydroxyl radicals act on organic contaminants either by hydrogen abstraction or by hydrogen addition to a double bond, the resulting radicals disproportionate or combine with each other forming many types of intermediates which react further to produce peroxides, aldehydes and hydrogen peroxide.

Electrochemical cells in which a chemical reaction is forced by added electrical energy are called electrolytic cells. Central to the operation of any cell is the occurrence of oxidation and reduction reactions which produce or consume electrons. These reactions take place at electrode/solution interfaces, where the electrodes must be good electronic conductors. In operation, a cell is connected to an external load or to an external voltage source, and electric

charge is transferred by electrons between the anode and the cathode through the external circuit. To complete the electric circuit through the cell, an additional mechanism must exist for internal charge transfer. This is provided by one or more electrolytes, which support charge transfer by ionic conduction. Electrolytes must be poor electronic conductors to prevent internal short circuiting of the cell.

The simplest electrochemical cell consists of at least two electrodes and one or more electrolytes. The electrode at which the electron producing oxidation reaction occurs is the anode. The electrode at which an electron consuming reduction reaction occurs is called the cathode. The direction of the electron flow in the external circuit is always from anode to cathode.

A typical electrochemical cell will have a positively charged anode and a negatively charged cathode. The anode and cathode are typically submerged in a liquid electrolytic solution which may be comprised of water and certain salts, acids or base materials. Generally speaking, gaseous oxygen is released at the anode surface while gaseous hydrogen is released at the cathode surface. A catalyst such as lead dioxide may be used to coat the anode to get greater ozone production. The anode substrate may be another material such as titanium, graphite, or the like.

The cathode and anode are positioned within the electrolytic cell with electrical leads leading to the exterior. The cell is also provided with appropriate plumbing and external structures to permit circulation of the electrolyte to a separate heat exchanger. Suitable inlet and outlet passages are also provided in the cell head space to permit the withdrawal of the gases evolved from the cathode (if gases are to be evolved) and from the anode. The two gas removal systems are typically maintained separate in order to isolate the cathode gases from the anode gases. Nitrogen and/or air may be pumped through the gas handling system in order to entrain the evolved cathode and anode gases and carry them from the cell to the exterior where they may be utilized in the desired application. Alternately, if a flow-through air or oxygen cathode is employed, its excess gases may be used for this purpose.

In order to maintain or cool the cell electrodes, heat exchange passages may be provided within the electrode structures. These coolant passages are connected to external sources of coolant liquid which can be circulated through the electrodes during the electrolysis process in order to maintain or reduce their temperatures.

In order to drive the electrolysis reaction, it is necessary to apply electric power to the cell electrodes. The electrodes are connected through the electrical leads to an external source of electric power with the polarity being selected to induce the electrolyte anion flow to the anode and the cation flow to the cathode. The power requirements are not appreciably different for those cells utilizing platinum anodes from those cells utilizing lead dioxide anodes. Electrical potentials on the order of from 2-3 volts D.C. are quite sufficient for the various cell configurations. The current requirements are most easily measured in terms of current density and may vary from a low of perhaps a tenth of an ampere per square centimeter (0.1 A/cm^2) up to current densities slightly beyond one ampere per square centimeter ($>1.0 \text{ A/cm}^2$). The power requirements are not necessarily dependent upon the electrolyte concentrations, nor in particular upon the anode materials. Thus, current densities of from about 0.1 A/cm^2 to about 1.5 A/cm^2 will produce maximum ozone current efficiencies at any electrolyte concentration with either beta lead dioxide anodes, or platinum anodes.

U.S. Pat. No. 4,316,782 (Foller) teaches that ozone yields as high as 52% could be obtained where the electrolyte is water and either the acid or salt form of highly electronegative anions, such as hexafluoro-anions are used. Here, the term "fluoro-anions" is used to describe that family of anionic (negatively charged) species in which multiple fluorine ligands complex a central atom. Electrolysis was carried out in a range between room temperature and the freezing point of water. The preferred anode materials for use in the electrolytic cells are either platinum or lead dioxide, especially lead dioxide in the beta crystalline form. Platinum, carbon, or nickel and its alloys may be used as hydrogen-evolving cathodes. Alternatively, an air or oxygen depolarized cathode may be employed which would greatly reduce the cell voltage and enhance the overall energy efficiency of the process.

Such electrolytic solutions can be highly corrosive to the cell materials if they are not selected properly, and especially hard on the electrodes where electrochemical discharge takes place. In addition, the liberated O_3 , being a powerful oxidizing agent, also strongly acts upon electrode materials which are susceptible to oxidizing action. The electrical properties of the electrode material are also important to the successful and effective operation of the ozone generating electrolytic cell. The electrodes must exhibit sufficient electrical conductivity to enable the utilization of current densities required by the ozone generating process without an unacceptable anode potential and must also be adaptable to whatever cooling procedures are required to maintain cell temperatures during operation.

Foller also disclosed that using an air or oxygen depolarized cathode provided several advantages. (1) The cell voltage would be substantially reduced since replacing hydrogen evolution with the reduction of oxygen theoretically saves 1.23 volts. (In actual practice a 0.8 volt swing is likely to be achieved.) (2) A separator between anode and cathode is no longer required, as no hydrogen is evolved to depolarize the anode. Further, savings in cell voltage are obtained by reducing IR losses. (3) The overall cell process becomes oxygen in and ozone out and the need for periodic additions of water is reduced. (4) The same air or oxygen fed to the air cathode could also serve to dilute and carry off the ozone that is anodically evolved by flowing through the cathode.

Air cathode technology has found recent favor in its application to fuel cells, metal-air batteries, and the chlor-alkali industry. The electrodes are generally composed of Teflon-bonded carbon containing small amounts of catalytic materials.

U.S. Pat. No. 4,375,395 (Foller) teaches that anodes made of glassy carbon are suitable for use in the preparation of ozone in an electrolytic cell utilizing an aqueous solution of the highly electronegative, fluoro-anions.

U.S. Pat. No. 4,541,989 (Foller) teaches that a liquid electrolyte containing acids of fluoro-anions, such as HBF_4 and HPF_6 , used in combination with a cool electrolyte solution can increase the efficiency and the ozone to oxygen yield. However, the use of a liquid electrolyte causes some problems. First, the electrodes in such electrolytic cell must be separated by a given distance to provide definition. This translates into power loss in the production of heat. Secondly, the presence of liquid electrolytes requires a sophisticated system of seals to prevent leaking of the electrolyte.

U.S. Pat. No. 4,836,929 (Laumann et al.) teaches the use of a solid electrolyte such as that made by duPont and sold under the brand "NAFION". This solid electrolyte was

placed between a lead dioxide anode and a platinum black cathode. The current efficiency was increased by oxygenating a water stream fed to the anode and the cathode. In this manner, oxygen could be reduced to water at room temperature releasing an increased yield of ozone.

In his paper entitled "Synthesis of Hydrogen Peroxide in a Proton Exchange Membrane Electrochemical Reactor" (April 1993), Fenton disclosed that paired synthesis of ozone (O₃) and hydrogen peroxide (H₂O₂) could be carried out in the same reactor. The electrochemical reactor used a membrane and electrode assembly (M&E) comprised of a "NAFION" 117 membrane between the platinum black/polytetrafluoroethylene (PTFE) anode and graphite/PTFE cathode. This M&E assembly was sandwiched between a carbon fiber paper (Toray Industries) on the cathode side and a platinum mesh (52 mesh, Fisher Scientific) on the anode side which were used as current collectors. This arrangement was alleged to produce some hydrogen peroxide.

Increasing the percentage of PTFE in the electrode increases the hydrophobicity of the electrode assembly and thus allows more of the gaseous reactant to reach the electrode surface by repelling the products formed. The graphite M&E with 20% PTFE produced slightly higher hydrogen peroxide than a similar M&E with 10% PTFE. This could be due to the mass transport limitation of oxygen to the membrane and electrode assembly within the less hydrophobic 10% M&E. It is preferred that the PEM reactor operate at potentials greater than 3.0 volts where the anodic evolution of ozone is favored.

Membranes containing perfluorinated sulphonic acids are typically prepared before use in an electrochemical cell by first soaking the membrane in hot water for about 30 minutes and then soaking it in 10% HCl to ensure that the entire membrane is in the H⁺ form. The membrane has to be kept moist at all times as it acts as a conductor only when it is wet. It is preferred that the proton exchange membrane be pretreated with an aqueous solution of sulphuric acid followed by rinsing the proton exchange membrane with pure water, rinsing the proton exchange membrane with an aqueous solution of hydrogen peroxide, and rinsing the proton exchange membrane with a final rinse of pure water. The final rinse should be made at a temperature between 50° C. and 150° C. and under pressure.

In their paper entitled "Paired Synthesis of Ozone and Hydrogen Peroxide in an Electrochemical Reactor," Pallav Tatapudi and James Fenton explain that the benefits of paired synthesis in electrolyte free water include: (1) lower energy consumption costs, as two oxidizing agents can be obtained for the price of one; (2) the elimination of the need for transportation and storage of oxidants by generating them electrochemically within water on demand at an amount proportional to the waste concentration; and (3) higher aqueous phase ozone concentrations.

U.S. Pat. No. 4,416,747 (Menth et al.) discloses an individual electrolysis cell bounded by bipolar plates and having a solid electrolyte made of perfluorinated sulphonic acids ("NAFION" by duPont) with a surface coating centrally located between current-collectors and adjoining open metallic structures. A plurality of individual cells may be integrated together between end plates so that the cells are electrically connected in series, hydrodynamically connected in parallel, and combined to form a block.

The current collectors disclosed in Menth may be close-meshed expanded metal covered by an open structure having a low resistance to the flow of a liquid in the direction parallel to the planar structure. The current collectors are preferably made from titanium. The ends of the cell are

formed, in each case, by a bipolar plate, which alternately acts as a cathode and as an anode. The bipolar plate is preferably made from stainless (Cr/Ni) steel. The space or chamber between the bipolar plates and the solid electrolyte is completely filled with water in which air or oxygen is suspended and/or dissolved.

The Menth assembly of the electrolysis cells basically corresponds to the filter-press type, with the liquid passing parallel to the principal planes of the cells instead of perpendicularly. The individual cells are held together between two end plates having electrical terminals, thereon.

The method and apparatus disclosed in Menth, however, can support only limited current density associated with reduction-oxidation, since oxygen has only limited solubility in water. Further, since the cathode chamber is filled with liquid water, the cathode electrode structure will become flooded with water. Higher current densities are desirable to cause an increase in the ozone production efficiency.

U.S. Pat. No. 4,836,949 (Laumann et al.) teaches a process for breaking down organic substances and/or microbes in pretreated feed water for high-purity recirculation systems using ozone which is generated in the anode chamber of an electrochemical cell and treated with ultraviolet rays and/or with hydrogen generated in the cathode chamber of the same cell or supplied from outside.

In light of the foregoing discussion, there exists a need for an economical method of producing ozone which will minimize voltage allowed for higher current density and produce a high concentration of ozone.

SUMMARY OF THE INVENTION

The present invention is a method for electrochemical synthesis of ozone. A source of a cathodic depolarizer is supplied to a cathode disposed in a cathodic chamber and water is supplied to an anode disposed in an anodic chamber. Electricity is then passed through an ionically conducting electrolyte that is disposed in the anodic and cathodic chambers such that the electrolyte is in intimate contact with both the anode and the cathode. The cathodic depolarizer is reduced at the cathode and the water is oxidized to ozone at the anode. The ozone gas produced at the anode is then withdrawn from the anodic chamber.

An apparatus for the electrolytic generation of ozone may comprise an anode, gas diffusion cathode and proton exchange membrane. The anode comprises a substrate and a catalyst coating wherein the substrate is selected from the group consisting of porous titanium, titanium suboxides (such as that produced by Atraverda Limited under the trademark "EBONEX"), platinum, tungsten, tantalum, hafnium and niobium, and wherein the catalyst coating is selected from the group consisting of lead dioxide, platinum-tungsten alloys or mixtures, glassy carbon and platinum.

The gas diffusion cathode comprises a polytetrafluoroethylene-bonded, semi-hydrophobic catalyst layer supported on a hydrophobic gas diffusion layer. The catalyst layer is comprised of a proton exchange polymer polytetrafluoroethylene polymer and a metal selected from the group consisting of platinum, palladium, gold, iridium, nickel and mixtures thereof. The gas diffusion layer has a carbon cloth or carbon paper fiber impregnated with a sintered mass derived from fine carbon powder and a polytetrafluoroethylene emulsion.

The ionically conducting electrolyte is typically a proton exchange membrane having a first side bonded to the catalyst layer of the gas diffusion cathode and a second side

in contact with the anode. The preferred material for the proton exchange membrane is a perfluorinated sulfonic acid polymer.

An apparatus for the electrolytic generation of ozone may comprise a plurality of individual electrolytic cells where each cell has an anode, gas diffusion cathode and proton exchange membrane, as described above. This multiple cell arrangement further includes first and second electrically insulating, chemically resistant gaskets disposed around the edges of the anode and cathode, respectively, having sections removed for internal manifolding to allow fluid flow to and from the electrode/electrolyte interfaces. First and second expanded metal communicates electrically between the electrode and an adjacent bipolar plate and facilitates fluid flow over the entire electrode surface. Each of these individual electrolytic cells are positioned in a filter-press type arrangement and connected in a series electrical circuit. The bipolar plate disposed between each of the individual electrolytic cells has a first side in electrical contact with the anode of a first adjacent cell and a second side in electrical contact with the cathode of a second adjacent cell. The apparatus also includes a set of two end plates having electrical connection means, an oxygen gas or air inlet port, a water inlet port, a cathode product outlet port and an anode product outlet port. Clamping means are used to secure the end plates and electrolytic cells tightly together.

Ozone may be electrochemically produced by supplying a source of oxygen gas to a gas diffusion cathode, wherein the gas diffusion cathode includes a gas diffusion layer and a catalyst layer. The gas diffusion layer comprises carbon cloth or carbon paper fiber impregnated with a sintered mass derived from fine carbon powder and a polytetrafluoroethylene emulsion. The catalyst layer comprises a proton exchange polymer, polytetrafluoroethylene polymer and a metal selected from the group consisting of platinum, palladium, gold, iridium, nickel and mixtures thereof. Water is supplied to an anode comprising a substrate and a catalyst coating. The anodic substrate is selected from the group consisting of porous titanium, titanium suboxides, platinum tungsten, tantalum, hafnium and niobium. The anodic catalyst coating is selected from the group consisting of lead dioxide, platinum-tungsten alloys or mixtures, glassy carbon and platinum. Electric current is then passed through the anode and the gas diffusion cathode, which are separated by a proton exchange membrane. The proton exchange membrane is comprised of a perfluorinated sulfonic acid polymer material that is bonded to the catalyst layer of the gas diffusion cathode.

BRIEF DESCRIPTION OF THE DRAWINGS

So that the manner in which the above recited features, advantages and objects of the present invention are attained and can be understood in detail, a more particular description of the invention, briefly summarized above, may be had by reference to the embodiments thereof which are illustrated in the appended drawings.

It is to be noted, however, that the appended drawings illustrate only typical embodiments of this invention and are therefore not to be considered limiting of its scope, for the invention may admit to other equally effective embodiments.

FIG. 1 is a cross-sectional side view of a depolarized ozone electrolysis cell;

FIG. 2 is a cross-sectional side view of a second embodiment of a depolarized ozone electrolysis cell;

FIG. 3 is a chart showing the variation of cell voltage with current density for the oxygen depolarized ozone electrolysis cell of FIG. 2

FIG. 4 is a chart showing the variation of ozone current efficiency with current density for the oxygen depolarized ozone electrolysis cell of FIG. 2;

FIG. 5 is a cross-sectional view of a multiple cell arrangement of the depolarized ozone electrolysis cell of FIG. 2 where the cells are electrically connected in a series circuit;

FIG. 6 is a schematic diagram of the apparatus of FIG. 5 in combination with ancillary equipment for the electrochemical production of ozone gas and/or ozonated water;

FIG. 7 is a schematic diagram of the apparatus of FIG. 6 in combination with ancillary equipment used in a process for the purification of water;

FIG. 8 is a chart showing the variation of cell voltage with current density for the air depolarized ozone electrolysis cell of FIG. 1;

FIG. 9 is a chart showing the variation of ozone current efficiency with electrochemical reactor temperature for the air depolarized ozone electrolysis cell of FIG. 1; and

FIG. 10 is a chart showing the variation of hydrogen peroxide production rate with current density for the air depolarized ozone electrolysis cell of FIG. 1.

FIG. 11 is a chart showing the variation of the percentage of spore strips sterilized with the duration of ozone exposure for spore strips enclosed in glassine envelopes;

FIG. 12 is a chart showing the variation of the percentage of spore strips sterilized with the duration of ozone exposure for spore strips without glassine envelopes;

FIG. 13 is a chart showing the variation of the fraction of negative biologic indicators with the duration of ozone exposure;

FIG. 14 is a flow diagram of a vessel for treating bulk grain with ozone to kill fungi; and

FIG. 15 is a flow diagram of a multiport arrangement for treating grain with ozone as the grain passes through an auger.

DETAILED DESCRIPTION OF THE PREFERRED EMBODIMENT

Conventional water electrolysis devices utilize hydrogen formation ($2\text{H}^+ + 2\text{e}^- \rightarrow \text{H}_2$) as the cathodic reaction. However, in an ozone forming electrolysis device, there are considerable benefits to eliminating the hydrogen formation reaction and replacing it with oxygen reduction reactions at the cathode. The benefits of eliminating hydrogen formation in electrolysis systems for ozone generation include: (1) lower operating cell voltage; (2) elimination of hydrogen gas explosions; (3) elimination of reactions between hydrogen and ozone in the product; and (4) the ability to provide paired electrosynthesis of ozone at the anode and hydrogen peroxide at the cathode.

The electrochemical reactions of the present invention occur by applying DC electricity between the anode and cathode. Water is fed to the anode side where two competing water oxidation reactions take place; the thermodynamically favored oxygen (O_2) evolution reaction Equation (1) and the ozone (O_3) formation reaction Equation (2).



Utilization of high overpotentials, such as anode potentials much greater than 1.3 volts, and certain electrode materials enhance ozone formation at the expense of oxygen evolution. The water oxidation reactions yield protons and

electrons which are recombined at the cathode. Electrons are conducted to the cathode via the external electronic circuit. The protons are carried through a solid electrolyte, such as a proton exchange membrane (PEM), which is available from duPont under the trademark "NAFION".

The cathodic reactions involving the reduction of oxygen are given below:

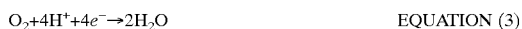

Specialized gas diffusion electrodes are required for these reactions to occur efficiently. The presence of oxygen at the cathode suppresses the hydrogen (H₂) formation reaction. Furthermore, the oxygen reactions are thermodynamically favored over hydrogen formation. In this manner, the reduction of oxygen to either H₂O or H₂O₂ reduces the overall cell voltage (i.e., the energy required to drive this system) below that required to evolve hydrogen (H₂) at the cathode in an aqueous solution.

The proton exchange membrane placed between the anode and cathode is made of a polymer material having sulfonate functional groups contained on a fluorinated carbon backbone. Two such materials include a "NAFION" PEM having an equivalent weight of 1100 grams and a Dow experimental PEM (XUS-13204.20) having an equivalent weight of 800 grams. While "NAFION" 105, 115 and 117 will each operate satisfactorily in the present invention, "NAFION" 117 is the preferred "NAFION" product. However, it is anticipated that a sulfonated polymer having a non-fluorinated carbon backbone would be operable according to the present invention. Such a polymer might include polystyrene sulfonate. Additionally, such a material might be coated with a fluorinated material to increase its resistance to chemical attack. It is also anticipated that a proton exchange membrane made of a Polymer material having carboxylate functional groups attached to a fluorinated carbon backbone would be operable according to the present invention. Examples include those available from Tokuyama Soda Company under the trademark "NEOSEPT-F", Asahi Glass Company under the trademark "FLEMION", Asahi Chemical Industry Company under the trademark "ACIPLEX-S" and Tosoh Corporation under the trademark "TOSFLEX IE-SA48." Further, polymeric systems based on: perfluoro bis-sulfonimides (CF₃-[CF₂SO₂NHSO₂CF₂]_n-CF₃); perfluoro phosphonic acids, and the corresponding carbanion acids would function satisfactorily as proton exchange membranes according to the present invention. The Dow experimental PEM gives much superior performance than the "NAFION" PEM materials, which are manufactured by DuPont. However, "NAFION" has been determined to be better for impregnating platinum electrodes.

The use of a PEM instead of a liquid electrolyte offers several advantages:

- fluid management is simplified and the potential of leakage of corrosive liquids is eliminated;
- the membrane serves as a separator between the anode and cathode; and,
- the PEM/anode interface provides a chemical environment which is suited to the electrochemical ozone formation reaction.

The preferred PEMs contain perfluorinated sulphonic acids that display a very high resistance to chemical attack, such as "NAFION" 117 and "NAFION" 115. Dow Chemical's experimental PEM XUS-13204.20 is the most preferred.

PEM-impregnated gas diffusion electrodes can be hot-pressed onto both sides of a purified proton exchange membrane, using a Carver hot press, to produce a membrane and electrode (M&E) assembly. The hot-pressing procedure involves placing a sandwich structure, consisting of the PEM and two electrodes—one at either side of the membrane—between the platens of the press at approximately 100 psi, where the platens having been previously heated to 100° C. After the temperature of the platens has been raised to within a preselected range of between, 125°C. and 230° C., a preselected pressure in the range 1,000 psi to 50,000 psi is applied to the membrane and electrode assembly for a period of time varying from 15 seconds to 150 seconds. The hot pressed M&E's should be immediately removed from the hot press and mounted in an electrochemical cell.

Preferred conditions for the preparation of M&E assemblies were found to consist of a hot press temperature of 215° C., a hot pressing time of 45 seconds and a hot press pressure in the range 3,000 psi to 14,000 psi.

Lead dioxide anodes for use in the electrolytic cells of the invention may be prepared by anodic deposition. The choice of anodic substrates on which lead dioxide is deposited are limited since most metals dissolve when deposition is attempted. However, the valve metals, such as titanium, titanium suboxides (such as that produced by Atraverda Limited under the trademark "EBONEX"), platinum, tungsten, tantalum, niobium and hafnium are suitable as substrates for the anodes. When titanium tungsten, niobium, hafnium or tantalum are utilized as substrate materials, they are first platinized to eliminate passivation problems sometimes encountered with the uncoated substrates.

Carbon in the form of graphite may be used as a substrate, however, lead dioxide adherence is a particular problem if the carbon has not been thoroughly degassed. The carbon is degassed by boiling in water for some time followed by vacuum drying over a period of days. When degassed, adherence is greatly improved with respect to thermal stress. Vitreous or glassy carbon does not appear to have the adherence problem.

Platinum is the most convenient substrate material to work with, gives the most uniform deposits, and does not present any additional problems. Platinum is therefore typically the most suitable substrate material for lead dioxide anodes. However, its high cost may make other previously mentioned substrate materials more practical for commercial use.

In any event, lead dioxide is plated onto substrates in a well known plating bath comprising essentially lead nitrate, sodium perchlorate, copper nitrate, and a small amount of sodium fluoride and water. The substrate material is set up as the anode in a plating bath with a pH maintained between 2 and 4. Current densities of between 16 and 32 milliamperes per square centimeter give bright, smooth and adherent lead dioxide deposits. Bath temperature is most usually maintained at about 60° C. at all times during deposition. The deposition is carried out with vigorous stirring of the electrolyte and rapid mechanical vibration of the anode to give consistently fine granular deposits free from pinholes or nodules. A surface active agent may be added to the plating solution to reduce the likelihood of gas bubbles sticking to the anode surface.

The limiting current for the cathodic reduction of dissolved oxygen in either water or aqueous solution may be described as follows:

$$i_l = \frac{(n \times F \times D \times C_0)}{d} \quad \text{EQUATION (5)}$$

where:

i_l is the limiting current;

n is the number of electrons consumed per oxygen molecule reduced to water;

F is the Faraday constant (96,484 Coulombs);

D is the diffusion coefficient of oxygen in water ($1.93 \times 10^{-5} \text{ cm}^2 \text{ s}^{-1}$);

C_0 is the concentration of oxygen in water ($1.41 \times 10^{-6} \text{ moles cm}^{-3}$); and

d is the diffusion layer thickness. (For a static liquid electrolyte, d is approximately 0.05 cm. For oxygen dissolved in a rapidly flowing or well-stirred solution, d is about 0.005 cm.)

Using the values given above, i_l for the reduction of dissolved oxygen in water is $2.1 \times 10^{-3} \text{ Amps/cm}^2$. Given this low value of i_l , operation of an ozone electrolysis device with the reduction of dissolved oxygen as the cathodic reaction is only possible at current densities considerably below those required for efficient ozone generation at the anode. A system which relies upon dissolved oxygen at the cathode can produce high yields of ozone, but only if hydrogen formation occurs at the cathode. The full benefits of oxygen reduction cannot be incorporated into this type of system where liquid water is allowed to flow over the surface of the cathode electrode structure.

The electrochemical reactor of the present invention provides pure air or oxygen gas to a gas diffusion cathode and feeds water only to the anode side.

The gas diffusion cathode consists of two layers: a semi-hydrophobic reaction layer (thickness of $5 \mu\text{m}$ to $100 \mu\text{m}$) and a hydrophobic gas diffusion layer optionally having an imbedded metallic current collector or a carbon cloth or carbon fiber paper. The preferred reaction layer for the reduction of oxygen at the cathode consists of platinum black with 30% PTFE. The gas diffusion layer consists of a mixture of 4 parts carbon black and 6 parts PTFE with no platinum catalyst and having an imbedded current collector, either a metal screen, carbon cloth, or fibrous carbon paper. This layer acts as a sponge to provide high concentrations of oxygen to the catalyst layer. In this manner, the rate of reaction at the cathode surface is no longer limited by mass transport of oxygen through water. The rate of reaction is therefore increased and is limited only by the rate of reaction at the catalyst surface/electrolyte interface. The use of the gas diffusion layer, together with oxygen gas or air, avoids the production of hydrogen gas and supports a high current density in the electrochemical cell.

It is important to recognize that the PTFE-impregnated carbon paper fiber is hydrophobic and therefore prevents saturation of the gas diffusion layer with water. Additionally, solubilized PEM may be brushed onto the front surface of a catalyst layer. By applying the PEM in intimate contact with the three dimensional catalyst surface, the oxygen reduction reaction can take place in all three dimensions. This three dimensional bonding is accomplished by following the hot pressing technique described above. This technique, however, requires temperatures near 220°C . which approaches the decomposition temperature of the perfluorinated sulfonic acid material.

Typically, the PEM membrane separating the anode and cathode must be kept moist. This is necessary to hydrate the sulfonate sites on the polymer to allow for proton transfer

through the membrane. Usually the membrane is kept moist by humidifying the oxygen source to the cathode. However, one alternative means of hydrating the membrane includes the use of tubes of approximately 4 to 9 mils diameter within the proton exchange membrane. These tubes are available from Perma-Pure, Inc. In this manner, water can be provided to the tubes along one edge of the membrane and spread throughout the membrane through capillary action.

An essential requirement of all ozone electrolysis processes is to operate at high current densities. This is because the efficiency of ozone generation is low at low current densities. At higher current densities, a higher proportion of the electrical current goes to the desired ozone formation reaction at the expense of competing or side reactions forming oxygen. The economics of ozone electrolysis systems dictate the need for operation at high current density. Firstly, because the energy cost per unit amount of ozone generated is at a minimum and secondly, the size of the electrodes, which determine the overall equipment cost, required to generate a given amount of ozone will be at a minimum when operating at high current densities where the efficiency of ozone formation is the greatest.

The dependence of the electrochemical reactor voltage on current density for various reactor temperatures is shown in FIG. 8. Cell voltages were recorded 30 minutes after applying each current density value to allow steady state condition to be reached. The reactor temperature was measured by a thermocouple probe located in the titanium end plate. The cell voltage increased linearly with increasing current density and decreased with increasing temperature at any selected applied current density. The variation of ozone current efficiency with reactor temperature for a number of current densities is given in FIG. 9. Current efficiency is the proportion of the current supplied to the cell that goes toward the desired product ozone (O_3). Current efficiency was determined by first finding the ideal yield if all the current goes to ozone production. The value of the ideal yield was then compared with the actual ozone yield. The relationship given below is used to determine the ideal yield:

$$\frac{i \times t}{n \times F} = \text{yield in moles of ozone produced} \quad \text{EQUATION (6)}$$

where:

i is the cell current in amps;

t is the time of electrolysis in seconds;

n is the number of electrons taking part in the reaction(6); and

F is the Faraday constant (96,484 Coulombs).

The current efficiency versus temperature profiles go through a maximum at approximately room temperature for all current densities. The profiles presented in FIG. 9 show that the current efficiency maximizes at 18 to 19 percent on operating the electrochemical reactor at a current density of 1.6 to 2.0 amps per square centimeter and a temperature of 23°C .

The DC electrical energy requirement (J) for ozone production in kilowatt hours per kilogram (kWh/kg) of ozone is given by the following equation (7):

$$J = \frac{E \times n \times F}{3600 \times N \times m} \quad \text{EQUATION (7)}$$

where:

E is the cell voltage;

13

n is the number of electrons released per mole of ozone formed (6);

N is the current efficiency; and

M is the molecular weight of ozone (48 grams).

As can be seen from the above figures, the reaction rate, 5 ozone current efficiency and conductivity of the PEM electrolyte are dependent upon temperature. Temperature is typically controlled by the circulation and heat exchange of the water flowing to the anode.

One advantage of the electrochemical methods of the 10 present invention is the ability to provide paired synthesis or paired electrosynthesis. The term "paired synthesis" means that the product generated at both the anode and cathode may be used together in a common application. For example, the present invention allows for selective genera- 15 tion of hydrogen peroxide, HO_2 , at the cathode and generation of ozone, O_3 , at the anode. Both of these desired products may be collected together and used in various applications, such as the treatment of waste water streams. Therefore, the process can generate twice as much oxidant 20 product as was possible before.

According to the present invention, an electrochemical cell for the production of ozone may be constructed by placing a proton exchange membrane between an anode and a cathode. The cathode may be coated with a semi- 25 hydrophobic catalyst material supported on a layer of carbon paper fiber impregnated with a sintered mass derived from fine carbon powder and Teflon emulsion. The anode is exposed to a source of water and the gas diffusion cathode is exposed to oxygen gas or air. An external electrical circuit 30 is necessary to provide electron flow from the anode to the cathode, while the PEM provides for proton flow. Also, the electrochemical cell must provide a means for collecting the produced ozone.

The present invention also encompasses the use of a 35 multiple cell arrangement, otherwise referred to as "filter press arrangement." This arrangement stacks individual cells back to back, in series, so that the current or electricity flows through one cell to the next. Each cell is separated by a bipolar plate which allows the electricity from the anode 40 of a first cell to pass through to the cathode of a second cell. Each cell must also be provided with a source of water to the anode surface and a source of oxygen gas to the gas diffusion cathode. These requirements of the present invention, may be accomplished through numerous embodiments. The preferred embodiment for carrying out the method of the present invention is disclosed as follows:

Referring to FIG. 1, a cross-sectional side view of a depolarized ozone electrolysis cell 10 is shown. A proton exchange membrane (PEM) or a solid polymer electrolyte 50 (SPE) 12, such as a perfluorinated sulfonic acid polymer, is disposed in the center of the cell. Bonded to one side (the cathodic side) of the solid electrolyte 12 is the electronically conducting, semi-hydrophobic, oxygen reduction electrocatalyst layer 14 of the gas diffusion cathode. This electrocatalyst layer 14 may be comprised of Teflon-bonded platinum black or carbon-supported high surface area platinum. The gas diffusion layer 16 of the gas diffusion electrode is integrally formed onto the catalyst layer 14.

On the other side (the anodic side) of the solid electrolyte 60 12 is an anode made, up of a catalyst layer 18 formed on a substrate 20. The electronically conducting, hydrophilic, ozone forming electrocatalyst layer 18 is made of lead dioxide (PbO_2) or a platinum-tungsten alloy (Pt/W). The substrate 20 is a porous, non-corroding electronically conducting support material that is preferred to be fabricated 65 using sintered titanium (or tantalum) particles.

14

Two non-conducting gaskets 17 and 21 are placed on either side of the solid electrolyte 12. The gaskets 17 and 21 have cutouts to fit around the perimeter of the cathodic gas diffusion electrode and the anodic substrate 20, respectively. The gasket should have a thickness greater than that of the cathodic gas diffusion electrode and the anodic substrate 20 so that it may be sufficiently compressed to seal liquids and/or gases.

The cathodic chamber of electrochemical cells of the present invention is surrounded and sealed with gasket materials well known to one skilled in the art. Gasket materials can be selected from the group consisting of neoprene, silicone rubber elastomer materials, Viton, Kalrez, and urethanes. The elastic nature of these materials compensate for any contraction/expansion encountered in electrochemical cells of the present invention under various operating conditions. Because of the highly oxidizing aggressive environment encountered in the anodic side of electrochemical cells, gaskets will be selected from the group of fluorocarbon-based polymeric materials consisting of polytetrafluoroethylene (PTFE or Teflon), chlorotrifluoroethylene, polytetrafluoroethylene containing organic or organic fillers, copolymer of tetrafluoroethylene and hexafluoropropylene (FEP), polyvinylidene fluoride (PVDF), and fluorocopolymers containing vinylidene fluoride and hexafluoropropene.

A cathodic depolarizer, typically a gas such as oxygen, enters the cell through port 22 which is in fluid communication with a series of channels 24 for fluid flow to the gas diffusion layer 16 of the cathode. The depolarizer gas and the products generated, such as liquid hydrogen peroxide, flow out of the cell 10 through port 26. The depolarizer flow is typically downward across the cathode so that the liquids generated can more easily be removed from the cell.

In a similar manner, water is fed into the cell 10 for exposure to the anode electrocatalyst layer 18 through port 28. The water flows through the channels 30 and out the port 32. The water flow is typically directed upward across the anode so that gaseous oxidation products do not become trapped in the cell.

The structure of the cell 10 is held together with two metal end plates 34 and 36. The metal end plates can be selected from the group of metals consisting of iron, nickel, copper, aluminum, stainless steels, Monel, Inconel, Hastelloy, titanium, tantalum, hafnium, niobium and zirconium. The preferred metal is titanium. The surfaces of the end plates can be plated with a noble metal selected from the group consisting of platinum, gold, palladium, ruthenium and iridium. The end plates 34 and 36 are secured together by a plurality of cell tie rods 38 having male threads and a plurality of nuts 40. To keep the endplates 34 and 36 electrically isolated from each other, a plurality of electrically insulating sheaths 42 and washers 44 are used in conjunction with each rod 38 and nut 40, respectively. Having electrically isolated the endplates 34 and 36, a positive terminal or busbar 46 and a negative terminal or busbar 49 can be connected to a DC power source (not shown).

Referring now to FIG. 2, a second embodiment of the present invention is shown. The electrochemical cell 50 is substantially similar to the cell 10 of FIG. 1, except that the channels 24 and 30 (shown in FIG. 1) have been substituted with non-corroding, electronically conducting, expanded metal 52 and 54, respectively. The expanded metal includes either an expanded metal sheet, a metal wire mesh or a metal foam. The expanded metal 52 and 54 still allow flow from port 22 to port 26 and from port 28 to port 32, respectively,

but provides a more turbulent flow pattern and leave a greater portion of the electrode surface area exposed to fluid flow. Also note that the gaskets **56** and **58** have a compressed width equivalent to the anodic substrate **20** plus the expanded metal **54** or the cathodic gas diffusion electrode plus the expanded metal **52**. A slot **59** has been cut in the gasket to allow flow from between the ports.

Now referring to FIG. 3, the variation of electrochemical cell voltage with current density applied to the anodic and cathodic electrodes of the cell represented schematically in FIG. 2 illustrated. It can be seen from FIG. 3 that the cell voltage, hence, the electrical energy consumed, decreases with increasing cell temperature for any given applied current density. In obtaining the data represented by FIG. 3, pure oxygen gas as a cathodic depolarizer, was fed into the cathode chamber of the cell represented schematically in FIG. 2 under a pressure of 40 psi. At the same time, water was recirculated over the anode surface under atmospheric pressure. The low cell voltages obtained on using oxygen gas as a cathodic depolarizer give rise to a considerable improvement over the corresponding cell voltages described in the state of the art.

Now referring to FIG. 4, the dependence of ozone formation current efficiency on the current density applied to the anode and cathode of the cell represented schematically in FIG. 2 is illustrated. High current efficiencies are only achieved as a result of applying high current densities which normally give rise to high cell voltages. However, with the present invention, the use of a cathodic depolarizer, for example, oxygen gas in the case, enables high current densities to be reached while maintaining low cell voltages. A high ozone current efficiency is desirable so as to make the apparatus as compact and as efficient as possible.

Now referring to FIG. 5, a cross-sectional view of a multiple cell arrangement **60** of the depolarized ozone electrolysis cell of FIG. 2 is shown, where the cells are electrically connected in a series circuit. The same numbering system as used in FIG. 1 and FIG. 2 has been incorporated into FIG. 5. Accordingly, FIG. 5 shows seven electrochemical cells separated by six bipolar plates **62**. The bipolar plate **62** of the present invention, can be made from a metal selected from the group of valve metals consisting of titanium, tantalum, hafnium zirconium or from the group of metals known as stainless steels which include SS304, SS316 and other high chromium/nickel-containing alloys. The bipolar plate can have a thickness in the range of 0.2–2 mm (8–80 mils). Both flat surfaces of the bipolar plate may be plated with a thin layer of a noble metal selected from the group containing platinum, gold palladium and iridium. The bipolar plate has sections removed for internal manifolding to allow fluid flow between adjacent cells.

The inlet port **28** and outlet port **32** are now in communication with inlet manifold **64** and outlet manifold **66**, respectively, which are comprised, a series of slots cut into the gaskets. In this manner, water is delivered to the anode **20** of each individual cell of the multiple cell arrangement **60** via manifold **64**, carried over expanded metal **54** of each individual cell, collected via manifold **66** and removed through port **32**. A similar manifold system for the cathode is positioned at 90 degrees of rotation from that for the anode.

FIG. 6 shows an apparatus **70** for carrying out a process for the electrochemical production of ozone gas and/or ozonated water. An electrochemical cell **72** is used for the production of ozone from water according to the apparatus of FIG. 5. Water is input to the cell **72** through port **28** and is removed bough port **32**, as described previously. The

water exiting port **32** contains entrained ozone gas. The ozone-laden water flows into a gas/liquid separator tank **74** via pipe **76**. The ozone then disengages from the water **80** and rises into the vapor space **82**. The ozone is removed from tank **74** through outlet pipe **84**. Makeup deionized water may be added to the tank **74** through pipe **86**.

The water **80** is withdrawn from tank **74** through pipe **88**. The water in pipe **88** may be either discarded by directing flow through valve **90** to pipe **92** or recycled by directing flow to the recycle line **94**. The recycle line **94** passes through a pump **96** before feeding the water into port **28**.

FIG. 7 is a schematic diagram of the apparatus of FIG. 6 in combination with ancillary equipment used in a process for the purification of wastewater **104**. The apparatus **100** is identical to that of FIG. 6 with the addition of a vessel **102** for purifying water. Ozone produced in electrochemical cell **72** and separated in tank **74** is delivered to vessel **102** through pipe **84**. The ozone is evenly distributed in the vessel **102** through a porous, non-corrosive metal tube **106**, preferably made of titanium, for introducing very fine O_3/O_2 gas bubbles into the water **104**. Ozone bubbles rise up through the water **104** and contact certain organic and biological material. The ozone, which may contain, hydrogen peroxide, is combined with ultraviolet light from serpentine-shaped UV lamp **108** to produce hydroxyl radicals which react non-selectively with dissolved organics first cause their complete oxidation to carbon dioxide (CO_2). Oxygen and carbon dioxide are then released from the vessel **102** through exhaust pipe **110**. The wastewater may be purified either as a batch process or continuously as will be apparent to one with ordinary skill in the art.

It will be apparent to one with ordinary skill in the art that the methods of the present invention may be accomplished through numerous equivalent embodiments including various geometric configurations.

The method of the present invention can include the disengagement of the product ozone gas from water. However, this can be easily accomplished in a vessel of short residence time what the ozone will quickly disengage from the water. In this manner, ozone may be collected in a concentrated gaseous product which facilitates its use in numerous applications. For example, the product ozone of the present invention may, be applied to severe waste water applications. Prior art devices such as those taught by Stucki require the intimate contact of the waste water with the anode. This caused numerous problems as the contaminants of the waste water would foul the anode and reduce cell efficiency. This problem has been overcome by the present invention.

EXAMPLE #1

Referring to FIG. 2 and to FIG. 6, a trial run of the disclosed invention was practiced. Lead dioxide, electroplated onto a sintered porous titanium substrate (Astro Met, Inc.), was used as the anodic electrode material. Prior to applying the lead dioxide electrocatalyst layer, the porous titanium substrate was first cleaned by glass bead blasting, followed by sonication in water, and plated with a thin layer of platinum, using a commercial plating solution (Engelhard Corporation). A commercially available platinum-catalyzed gas-diffusion electrode (ELAT, E-TEK, Inc.) was used as the cathodic electrode material. The anodic and cathodic structures each had in active area of 25 cm^2 . The anodic and cathodic electrocatalyst layers were impregnated with a 5 wt % Nasion® solution in a mixture of lower aliphatic alcohols and 10% water (obtained from Aldrich Chemical Company) and dried, yielding PEM loadings of -0.6 mg. cm^{-2} . The

PEM-impregnated cathodic gas-diffusion electrode was bonded to one side of a precleaned Dow experimental proton exchange membrane (XUS-13204.20) by means of hot-pressing under optimum conditions. The PEM-impregnated lead dioxide-plated porous titanium substrate (as the anodic electrode) was placed on the other side of the Dow proton exchange membrane.

The membrane and electrode assembly obtained, along with two pieces of platinum-plated expanded titanium metal (where one each of the expanded metals was in contact with the other planar surfaces of the anodic and cathodic electrodes), together with two Teflon gaskets, were inserted between two platinum-plated titanium endplates of a single electrochemical cell, representative of that shown schematically in FIG. 2. The chemically stable Teflon gaskets were used to seal the cell components on bolting the endplates, together with electrically insulated bolts and nuts, using a torque of 50 inch-pounds. Electrical connections between the positive and negative endplates and a Hewlett-Packard model 6572A DC power supply were made, using insulated wire leads. Two additional screws, placed on the sidewall of each endplate, allowed the measurement of cell voltages, using a Fluke (model 8050A) digital multimeter.

Performance characterizations of the single electrochemical cell were carried out using the test apparatus shown in FIG. 6. Teflon swagelok fittings and Teflon tubing were used in connecting the electrochemical cell to the source of pressurized oxygen gas, Teflon-lined pump (Cole-Parmer micropump model 020-000), water/gas separator (water reservoir) and gas-phase ozone analyzer. The water/gas separator (water reservoir) was made of Pyrex glass. Pure oxygen gas as a cathodic depolarizer was supplied in the manner of a single pass to the cathodic inlet port from a pressurized cylinder at a pressure of 40 psi. To maintain a pressure of 40 psi within the cathode space in the electrochemical cell, a back-pressure regulator set at 40 psi was connected to the cathodic outlet port. While maintaining a constant pressure of 40 psi, an oxygen gas flow rate through the cathode space of the electrochemical cell of 500 ml min⁻¹ was achieved. Water was recirculated continuously over the surface of the anode at a flow rate of 200 ml min⁻¹ from the water reservoir which contained 300 ml of water. The return water recirculation loop passed through a heat exchanger (Astro Metallurgical, Inc.; ACX heat exchanger, model 4X8-14) before entering the anodic inlet port.

An ozone monitor (Ozone Research and Equipment Corporation, model 03M-110) was used for measuring gas-phase ozone concentrations. The ozone-containing gas stream was separated from the fluid flow exiting from the anodic outlet port in the water/gas separator at atmospheric pressure. The gas stream was then fed into the inlet of the ozone monitor under atmospheric pressure. This instrument measures the absorption of UV light by ozone at 254 nm and provides a direct determination of ozone concentrations in terms of mg/standard liter or mg min⁻¹. Knowing the amount of electrical charge passed during the electrochemical formation of ozone allowed a determination of its current efficiency to be made.

The experimental parameters varied systematically were the applied current density and electrochemical cell temperature. The corresponding parameters measured were the cell voltage and the concentration of ozone in the gas phase. The dependence of electrochemical cell voltage on current density for various cell temperatures is shown in FIG. 3. Cell voltages were recorded 60 minutes after applying each current density value, so as to allow steady state conditions to be reached. Constant electrochemical cell temperatures

were maintained by circulating water from a large constant temperature water bath (Lauda model K-4IRD) through the heat exchanger. The cell temperature close to the PEM/electrode interfaces was measured by means of a thermocouple probe placed in a thermo well that was drilled into the sidewall of one of the titanium endplates at a location close to the electrode surface. It can be seen from FIG. 3 that the cell voltage increases rapidly at low current densities followed by a more gradual increase at higher current densities. However, the cell voltage decreases with increasing temperature at any given applied current density. The cell voltage is a combination of the reversible cell voltage, overpotential losses at each electrode and ohmic drops internally within the M&E assembly and in the external electrical connections.

The variation of ozone current efficiency with applied current density for a number of electrochemical cell temperatures is presented in FIG. 4. For all current densities, the ozone current efficiencies were highest for the lowest cell temperature and decreased for any given current density with increasing temperature. At the lowest temperature, the ozone current efficiency-current density profile approached a maximum current efficiency of the order of 15% at a current density of approximately 2.5 A cm⁻².

It is apparent from the profiles given in FIG. 3 that the energy required to impress a given current density between the anode/proton exchange membrane/cathode sandwich decreases with increasing electrochemical cell temperature. The profiles given in FIG. 4 show that, at high current densities, the ozone current efficiency is only slightly affected with increasing electrochemical cell temperature.

At a current density of 1.6 A cm⁻², the rate of ozone production by the electrochemical cell was 25 mg of O₃ per minute. Taking the electrochemically active dimensions of the cell (5 cm×5 cm×0.6 cm), yields a volume of 15 cm³. This illustrates the compact nature of the electrochemical cell of the present invention. Since single cells of the present invention can be stacked in series to form a unitary structure, as represented schematically in FIG. 5, further stacking will result in a high ozone output within extraordinarily compact dimensions.

EXAMPLE #2

Referring now to FIG. 1 and FIG. 6, another example of the performance derived from the disclosed invention is outlined. The anodic electrode was prepared in a manner identical to that described in Example #1 above. However, a PEM-impregnated high surface area palladium black-catalyzed, gas-diffusion electrode was used as the cathodic electrode material. The palladium electrocatalyst layer was prepared by adding 3 ml of water to 1.68 g of high surface area palladium black powder (Johnson Matthey, Inc.) and medicated for 20 minutes. 0.22 g of Teflon emulsion (available from duPont) was added to this mixture, followed by 20 minutes of additional sonication, the mixture was then applied to one side of a commercially available gas-diffusion electrode (E-TEK, Inc.) and heated in an inert atmosphere at 350° C. for three hours.

The PEM-impregnated anodic and cathodic electrode structures, each having an active area of 5 cm², were bonded on either side of a precleaned segment of Nafion 117 PEM material. The membrane and electrode assembly obtained, together with two Teflon gaskets, were inserted between titanium endplates of a single electrochemical cell, represented schematically in FIG. 1. The inner surfaces of the titanium endplates were electroplated with a thin platinum

film to prevent poorly electronically conducting oxide film growth on the surfaces of the endplates. Humidified air was supplied to the inlet port of the cathodic endplate from a pressurized air cylinder. A back pressure regulator was connected to the cathodic outlet port and set to give an air pressure within the cathode space of the electrochemical cell of 80 psi, while allowing an air flow rate of 500 ml min⁻¹. Water was recirculated continuously over the back surface of the anode at a flow rate of 150 ml min⁻¹. The anodic water reservoir had a volume of 500 ml.

Performance characterizations of the single electrochemical cell were carried out using the experimental test apparatus shown in FIG. 6 and as described in Example #1 above, except that electrical connections on the outside surfaces of the titanium endplates were made to a Hewlett-Packard (model 6282A) DC power supply. Cell voltages were recorded 30 minutes after applying each current density value, so as to allow steady state conditions to be reached. The dependence of electrochemical cell voltage on current density for various cell temperatures is shown in FIG. 8. The cell voltages increased almost linearly with increasing current density and decreased with increasing temperature for any given applied current density.

Dissolved hydrogen peroxide in water electroosmotically transported through the proton exchange membrane was sampled at the exit port from the cathode endplate, shown in the schematic given in FIG. 1. Hydrogen peroxide concentrations were measured using an Orbeco Aqua Analyzer II spectrophotometer. Dissolved ozone concentrations were determined by colorimetry at 600 nm, using samples of ozonated water withdrawn from the water/gas separator, shown in the schematic given in FIG. 6. The highest dissolved ozone concentrations in water, measured at atmospheric pressure, were in the range 10–20 ppm. The values of dissolved ozone were influenced considerably by the temperature of the electrochemical cell. Ozone gas concentrations were determined, as described in Example #1 above, using gas samples withdrawn from the water/gas separator, as illustrated in FIG. 6.

The variation of ozone current efficiency with electrochemical cell temperature for a number of current densities is given in FIG. 9. The current efficiency-temperature profiles go through a maximum at approximately room temperature for all current densities. This is a considerable advantage for the PEM-based electrochemical cell of the present invention. The profiles presented in FIG. 9 show that the current efficiency maximizes at 18–19% on operating the electrochemical cell at a current density of 1.6–2.0 A cm⁻² and a temperature of 25° C.

The electrochemical cell, represented schematically in FIG. 1, yielded an ozone production rate of 5 mg of O₃ per minute. The cell had electrochemically active dimensions of 2.24 cm×2.24 cm×0.3 cm giving a volume of 1.5 cm³. Again this example illustrates the compact nature of the electrochemical cell of the present invention for the production of ozone gas.

Variation of the hydrogen peroxide production rate with applied current density on operating the electrochemical cell represented schematically in FIG. 1 in a paired oxidant synthesis manner is given in FIG. 10. The hydrogen peroxide production rate increases with increasing current density and approaches a maximum value at an applied current density of 1.6 A cm⁻². Because of the low hydrogen peroxide production rates, calculated current efficiencies were very low and, in all cases, were less than 1%.

Another embodiment of the present invention may be referred to as an electrochemical cell for the production of

ozone incorporating a cathodic depolarizer. A cathodic depolarizer totally eliminates hydrogen evolution at the cathode and may lower the cell voltage required to produce ozone.

Application of a DC source of electrical energy to two electronically conducting electrodes immersed in an aqueous electrolyte can bring about the decomposition of water molecules into their constituent elements, namely hydrogen and oxygen gases. This process is particularly favored if the anions and cations associated with the electrolyte do not undergo electrochemical reactions at the electrode/solution interfaces. Aqueous solutions of acids, salts and bases are most commonly used as electrolyte solutions. The mineral acids: sulfuric; phosphoric; tetrafluoroboric and hexafluorophosphoric are particularly suitable. It is also anticipated that phosphonic, sulfonic, perfluoro bis-sulfonimides and the corresponding carbonion acids in monomeric, dimeric or oligomeric forms would be operable according to the present invention. Supplying an external source of DC electrical energy to an electrochemical cell that brings about the decomposition of water is referred to as an electrolysis process and the electrochemical cell is referred to as an electrolysis cell. In order to minimize heating effects within the electrolysis cell and, hence, to lower the consumption of electrical energy, the positive and negative electrodes are placed as close as possible to each other without short circuiting taking place. In order to minimize the space between the positive and negative electrodes, a separator material is usually placed between them. Separators are thin film materials, either inorganic (asbestos) or organic (Daramic or Celgard) in nature, and are electrical insulators containing microporous channels or pathways that allow flow of ions through the material. A requirement for a separator to be used is that it should be well wetted by the electrolyte solution in the electrolysis cell and should be chemically and electrochemically stable.

In aqueous acid solutions, the decomposition of water involves two electrochemical reactions which take place at the positive and negative electrodes. At the positive electrode, water molecules are oxidized, liberating oxygen gas and protons (which transport ionic current in the solution) and electrons which flow through the external circuit and power source to the negative electrode. This electrochemical reaction is represented by Equation [8] and has a standard electrode potential of 1.23 V.

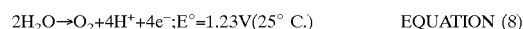

At the negative electrode, the protons recombine with the electrons to liberate hydrogen gas, which is represented by Equation [9] and has a standard reversible potential of 0.00 V.

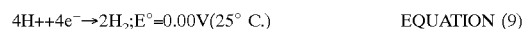

If the nature of the catalytic surface of the positive electrode is changed, a competing electrochemical water oxidation reaction may become more favorable. This competing water oxidation reaction involves the liberation of ozone gas and is represented by EQUATION [10] which has a reversible potential of 1.51 V.

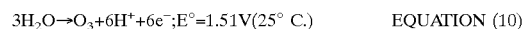

Based on thermodynamic criteria, it is apparent from Equations [9] and [10] that the minimum cell voltage required to decompose water electrochemically into hydrogen and ozone gases under standard conditions requires a minimum of 1.51 V to be applied between the positive and negative

electrodes. Due to electrical resistance in the electrolyte solution between the positive and negative electrodes and the overpotentials required in order to make reaction [9] and [10] and proceed at significant rates at 25° C., the actual cell voltage will be on the order of 3.0 V.

As a first step to lower this actual cell voltage and, hence, minimize the consumption of electrical energy, the electrodes need to be placed as close as possible to each other. This is greatly facilitated by the use of an ion exchange membrane, such as the proton exchange membrane, which can have thicknesses in the range 50–175 μm (2–7 mils). Use of an ion exchange membrane can yield a so-called “zero gap” between the positive and negative electrodes. It is also advantageous if the ion exchange membrane is a proton-conducting membrane, such as perfluorinated sulfonic acid polymer sold by DuPont under the trademark “NAFION” 117, which would enable the electrochemical reaction to proceed as described by Equations [9] and [10].

A second step in lowering the cell voltage and, hence, minimizing electrical energy consumption, is to coat the positive and negative electrodes with electrocatalyst layers that speed up the rates of the hydrogen evolution reaction and the ozone formation reaction. It is well known that platinum is the most effective electrocatalyst for hydrogen evolution, particularly in acid solutions, and that lead dioxide is highly effective for the electrochemical formation of ozone from water. However, placing the electrodes as close as possible to each other and using the most effective anodic and cathodic electrocatalysts may lower the cell voltage only a few hundred millivolts.

It is almost impossible using these approaches to reduce the cell voltage for the electrochemical production of ozone

able and the cell voltage would be reduced. The selection criterion for chemicals that could partake in an alternative cathodic reduction reaction, that is, function as cathodic depolarizers, is that they have a thermodynamic reversible potential more positive than that corresponding to the evolution of hydrogen gas, which is represented by Equation [9]. It is also desirable that these cathodic depolarizers be abundantly available, or readily reoxidizable, for recycling into the electrolysis cell.

Examples of potential cathodic depolarizers that could be used in an electrolysis cell containing an acidic electrolyte and which could be combined with the anodic oxidation of water, liberating ozone gas, are given in Table 1, including oxygen. As seen from the table, some of these cathodic depolarizers exist in the gas phase, while others are acids or salts and can be exploited only when dissolved in water. All of the cathodic depolarizers identified in Table 1 support high electrochemical reaction rates, that is high current densities at low overpotentials. This is particularly true if these depolarizers are utilized in conjunction with appropriate cathode electrode structures. In the case of the gas-phase cathodic depolarizers, a gas-diffusion electrode would be most suitable. However, for the cathodic depolarizers that can be only used when dissolved in water, flow-by, flow-through, packed-bed and fluidized-bed electrode structures are more advantageous in order to achieve high current densities.

The gaseous-phase cathodic depolarizers could be supplied to the negative electrode under pressure, which would further increase the electrochemical reaction rate, that is, allow even higher current densities to be realized. The use of a proton exchange membrane as the

TABLE 1

Cathodic Depolarizer	Depolarizer Phase	Cathodic Reaction	Reversible Potential at 25° C.	Theoretical Cell Voltage with O ₃ Evolution as Anodic Reaction
Chlorine	Gas Phase	$\text{Cl}_2 + 2\text{e}^- \rightarrow 2\text{Cl}^-$	1.36 V	0.15 V
Bromine	Gas Phase	$\text{Br}_2 + 2\text{e}^- \rightarrow 2\text{Br}^-$	1.09 V	0.42 V
Chlorine Dioxide	Gas Phase	$\text{ClO}_2 + \text{H}^+ + \text{e}^- \rightarrow \text{HClO}_2$	1.277 V	0.23 V
Dinitrogen Tetroxide	Gas Phase	$\text{N}_2\text{O}_4 + 4\text{H}^+ + 4\text{e}^- \rightarrow 2\text{NO} + 2\text{H}_2\text{O}$	1.035 V	0.475 V
Oxygen	Gas Phase	$\text{O}_2 + 4\text{H}^+ + 4\text{e}^- \rightarrow 2\text{H}_2\text{O}$	1.23 V	0.28 V
Air	Gas Phase	$\text{O}_2 + 4\text{H}^+ + 4\text{e}^- \rightarrow 2\text{H}_2\text{O}$	1.23 V	0.28 V
Ferrie Chloride	Aqueous Solution	$\text{Fe}^{3+} + \text{e}^- \rightarrow \text{Fe}^{2+}$	0.77 V	0.74 V
Benzoquinone	Aqueous Solution	$\text{BQ} + 2\text{H}^+ + 2\text{e}^- \rightarrow \text{HQ}$	0.70 V	0.81 V
Hypobromous Acid	Aqueous Solution	$\text{HBrO} + \text{H}^+ + 2\text{e}^- \rightarrow \text{Br} + \text{H}_2\text{O}$	1.33 V	0.18 V
Hypochlorous Acid	Aqueous Solution	$\text{HClO} + \text{H}^+ + 2\text{e}^- \rightarrow \text{Cl}^- + \text{H}_2\text{O}$	1.48 V	0.03 V
Sodium Ferricyanide	Aqueous Solution	$[\text{Fe}(\text{CN})_6]^{3-} + \text{e}^- \rightarrow [\text{Fe}(\text{CN})_6]^{4-}$	0.36 V	1.15 V
Sodium Nitrate	Aqueous Solution	$\text{NO}_3^- + 3\text{H}^+ + 2\text{e}^- \rightarrow \text{HNO}_2 + \text{H}_2\text{O}$	0.93 V	0.58 V

from water much below 3.0 V. A different result is achieved if the cathodic reduction product is not hydrogen but involves another reaction leading to a different product. Suppose that the hydrogen evolution reaction is replaced by a cathodic reduction reaction taking place at a more positive potential than that at which hydrogen is evolved; then the reversible potential for this reaction would be more favor-

60 electrolyte greatly facilitates the use of pressure on introducing the cathodic depolarizer into the electrochemical cell, since it will prevent the removal from the cathode chamber, as would occur with a liquid electrolyte solution, and will allow the electrolysis cell to function, even with different pressures in the cathode chamber and in the anode chamber. Furthermore, the ozone product can be delivered

out of the cell under pressure suitable for immediate use in pressurized applications. Since the proton exchange membrane also functions as a separator, it prevents transfer of the cathodic depolarizer and its electrochemical reduction products from diffusing or migrating into the anode chamber, where they could interfere with the evolution of ozone gas from water.

The ozone produced by the electrochemical synthesis of the present invention may be utilized either in aqueous solutions directly from the cell or after disengaging the ozone gas from the water. Aqueous ozone may be preferred in such applications as wastewater treatment and purification. The aqueous cell effluent containing solubilized ozone gas is added into a wastewater stream containing organic substances where the ozone gas can react with the organic substances. The reaction mechanism, as described above, may optionally be assisted by exposing the ozone-containing wastewater stream to ultraviolet radiation which promotes the formation of hydroxyl and peroxy radicals. It is preferred that a residual of ozone be maintained in the wastewater stream until immediately prior to use, at which time, the ozone should be eliminated from the water. The ozone can be eliminated either by decomposition or disengagement.

Some ozone applications require that the ozone gas be separated from the water and applied in the gas phase. Typically, the ozone gas will be fed to a chamber where the ozone gas can react with a given reactant material. In applications requiring high concentrations of ozone, this chamber may be evacuated of air to avoid dilution of the ozone. Following completion of the reaction, the ozone is eliminated from the chamber and the chamber is filled with air to allow safe handling and removal of sterilized items. Ozone may be eliminated from the chamber by decomposition or by evacuation of the ozone gas.

In order to improve the conditions for sterilization or disinfection of biological materials and residues within the chamber, the temperature, pressure and humidity inside the chamber may be controlled. Control of conditions in the chamber is most important where the chamber is a chemical reaction vessel. In a chemical reaction vessel, the ozone will react with other chemical reactants to produce a commercial product rather than the sterilization of biological materials.

STERILIZATION AND DISINFECTION

A second application for the ozone of the present invention is the sterilization of medical/dental tools and apparatus. Currently, medical instruments are sterilized in ethylene oxide-containing cabinets where the instruments are exposed to ethylene oxide for a period of 4 to 5 hours. The disadvantages of such systems include the fact that the ethylene oxide is extremely flammable in any concentration when combined with oxygen and is also a carcinogen. In addition, under certain conditions, such as a battlefield, there is insufficient time to allow adequate sterilization of instruments. Therefore, there is a need for quick and efficient sterilization of medical instruments as would be provided by the highly concentrated ozone of the present invention.

An ozone sterilization chamber was built by completely refitting a surplus AMSCO EtO sterilizer (Model AM-23, American Sterilizer Company, Erie, Pa), with polytetrafluoroethylene gas lines, electrical wiring, new cycle timers, polytetrafluoroethylene gaskets, and a vacuum air purge system. The only portions of the original device that were salvaged were the stainless steel chamber and the exterior heating blanket (this required a new controller). A 400 cm² active electrode area ozone generator with a gas feed rate of

2.2 liters per minute (lpm) was used for a breadboard sterilizer. The ozone concentration in the output from the generator was between 10 and 12 wt%. The ozone generator had a power consumption of 2.4 kilowatts. Total volume of the sterilizer chamber was 40 liters. Elevated humidity in the chamber was achieved by keeping an open container of distilled H₂O inside the chamber while cycling the sterilizer, further the ozone/oxygen mixture generated by the electrochemical reactor is in a near-water saturated state when it leaves the ozone generator. The air exhaust system utilized a piston air pump. The ozone concentration was measured spectrophotometrically at 254 nm using a Shimadzu UV spectrophotometer (Model UV-2101PC, Shimadzu Corp., Japan), integrated with a computer for data evaluation.

The sterilizer is normally operated with a continuous feed of ozone gas into (and out of) the chamber. This is referred to as the "flow through" mode. There are three phases of the sterilization cycle: 1) evacuate; 2) sterilize; and, 3) flush. Each phase of the cycle is described below.

After samples have been loaded and the chamber door is secured, the evacuation is initiated through a vacuum block valve which opens to a vacuum pump. The chamber air is evacuated through the vacuum pump and out an air purge valve. After approximately 5 minutes, a vacuum of 30" Hg is reached.

Sterilization can be initiated after about 5 minutes of evacuation. The vacuum pump is turned off and the vacuum block valve is closed prior to introducing ozone into the chamber. Ozone gas is made to flow continuously through the chamber at approximately 2 liters per minute. The pressure in the chamber may be maintained close to atmospheric, but it is preferred that the pressure be greater than about 20 psi. The length of the sterilizing phase is also the duration of ozone exposure of the samples in the chamber. Testing of the sterilizer was conducted using four sterilizing times (i.e., 30, 45, 60 and 90 minutes).

At the end of the ozone treatment period, the flush phase of the cycle is initiated using a vacuum pump to evacuate the chamber. The chamber can then be opened and the samples removed.

The operating procedure and cycle events above were modified in some experiments to investigate the effects of pressuring the chamber during ozone treatment. This is referred to as the "pressure" mode. The difference from "continuous flow" mode was that immediately at the start of the sterilizing phase, ozone was diverted into the sterilization chamber but the chamber outlet was closed to create a back pressure. This meant that once the vacuum inside the chamber was broken, the pressure inside the chamber built up. This meant that the samples were subjected to an increased ozone gas pressure during the sterilization phase of the cycle. The chamber was flushed in the normal way.

Static ozone gas treatment was investigated by subjecting samples to a single chamber filling of ozone. This is referred to as the "single fill" mode. This was accomplished by modifying the sterilizing phase so that once vacuum was broken and the ozone concentration in the chamber was 10wt %, both the inlet and outlet valves were closed. This seals the ozone in the chamber with no further gas inflow, hence the samples are maintained in a static ozone atmosphere for the remainder of the sterilization phase. The flush phase was accomplished in the usual way.

Paper spore strips (Duo-Spore, Propper Manufacturing Co., Inc., Long Island City N.Y.) containing *Bacillus stearothermophilus* and *Bacillus subtilis* var. *niger* were used for all tests. Spore strips were tested both with and without

glassine envelopes. The strips were placed on a metal rack at a height mid-way between the top and the bottom of the chamber. A minimum of four spore strips were placed in the chamber for each run. For each run, two non-ozone treated spore strips were used as controls. They were aseptically removed from their envelope and placed immediately in sterile nutrient both (NB). All control strips showed vigorous growth in NB within 24 hours.

Following ozone treatment, spore strips were aseptically removed from the chamber and placed in individual tests tubes containing 9 ml of sterile NB. The strips were incubated at 37° C. for 21 days. If no growth was visible after 21 days, the strips were heat shocked. Heat shocking was accomplished by placing the tubes containing the strips into an 80° C. water bath for 20 minutes. The tubes were then returned to the incubator for an additional 14 days. Any strips not showing growth at the end of this time were classified as "sterile".

FIGS. 11 & 12 illustrate the results obtained from over 80 evaluations of the sporicidal activity of ozone under different chamber conditions and exposure times. A minimum of 4 replicate spore strips were used for each evaluation. Typically each spore strip contained in excess of 10^6 spores (e.g., 6.0×10^5 spores of *Bacillus stearothermophilus* and 5.0×10^6 spores of *Bacillus subtilis* var. *niger*). The results of these evaluations are expressed in terms of "% of spore strips sterilized" for each exposure time period and each operational mode. Overkill was achieved when 100% of the spore strips were sterilized.

FIG. 11 contains the results of tests conducted on spore strips enclosed in glassine envelopes. FIG. 12 shows the results of tests conducted on spore strips which had been removed from the glassine envelopes. These data clearly show that the glassine envelopes (FIG. 11) had a small but observable negative effect on the sporicidal activity of ozone. The glassine envelopes represented a physical barrier which delayed the contact and penetration of ozone into the spores, thus decreasing the overall sporicidal efficiency of the ozone.

The results seen in FIGS. 11 & 12 clearly demonstrate that the "pressure" mode of operation was the most effective. An increase of chamber pressure significantly enhanced sporicidal activity, and overkill was achieved after a 45 minute exposure. The "flow through" scheme was the next most effective mode of operation. This operational mode displayed a significantly lower level of spore inactivation at the 30 and 45 minute exposure times than did the "pressure" mode. With this operational mode, overkill was achieved after a 60 minute exposure. The "single fill" was the least effective operational mode. A 90 minute ozone exposure was required to achieve overkill.

FIG. 13 shows the results of experiments on the sterilizing effects of ozone at 1, 3 and 9 weight percent (wt %) using Biological Indicators (BIs). The biological indicator was spores of the bacterium *Bacillus subtilis* var *niger* on ceramic penicylinder carriers. The BIs were mixed with a medical waste load, which was continuously agitated. The results are expressed as the fraction of negative BIs (i.e., the fraction of treated BIs that showed no growth after 14 days). The graph shows that the time required for overkill (total inactivation of spores) depended on the ozone concentration. Increasing the ozone concentration decreases the time required for overkill. Overkill was achieved after 30 minutes at 9 wt %, 60 minutes for 3 wt% and between 90 and 120 minutes for 1 wt % ozone.

A D-value is defined as the amount of time required by a sporicidal agent to effect a one log reduction in the number

of viable spores present in a sample. The D-values given for the experiments conducted during this work were extrapolated from the overkill time requirements. The extrapolation was based on the following assumptions: 1) individual spore strips contained in excess of 10^6 spores; and 2) the time required to achieve overkill (100%) represented a six log reduction. Based on these assumptions, the "pressure" mode with an overkill time requirement of 45 minutes yielded an extrapolated D-value of 7.5 minutes. The "flow through" mode achieved overkill at 60 minutes, this yielded an extrapolated D-value of 10 minutes. While the "single fill" mode required 90 minutes to achieve overkill, resulting in an extrapolated D-value of 15 minutes.

A sterilization cycle time of approximately one hour was chosen to make this technology competitive with steam and hydrogen peroxide sterilization systems. Therefore, the ozone production rate and the instrument sterilization volume was sized to match the 1 hour sterilization period.

One preferred sterilization system has the ability to sterilize both 18"x6"x3" nalgene and 12.5"x8.25"x2.5" stainless steel standard sterilization trays. This, in effect sets both the sterilization chamber column and dimensions which are 11 liters of 20"x9.75"x3.5" respectively. Furthermore, as a baseline, an electrochemical cell stack capable of producing a total gas flow rate of 2.2 lpm was selected. With a sterilization chamber volume of 11 liters and a gas flow rate of 2.2 lpm, it will take approximately five minutes to fill the chamber (provided the ambient air initially occupying the chamber is first evacuated). An ozone exposure time of 60 minutes is all the time required to sterilize commercial spore strips, leaving five minutes to purge the chamber after the sterilization period has elapsed. Thus, a sterilization cycle time of just over an hour was achieved.

The above operating sequence is the core design rationale for development and operation of the ozone sterilizer prototype. However this design rationale does not address the continuous operating characteristic of the cell stack. Only small amounts of ozone are required to maintain the concentration in the sterilization chamber. But the cell stack is continuing to generate the ozone/oxygen mixture at a total gas flow rate of 2.2 lpm and power is being consumed during this time. Additionally, ozone continues to be generated during preparation and retrieval of the instruments from the sterilization chamber.

To fully utilize the continuous ozone generating characteristic of electrochemical cells, multiple sterilization chambers may be used. Furthermore, the sterilization chambers may be capable of being removed from the main sterilization system in order to allow new chambers to be sterilized. These portable sterilization chambers or "cassettes" working in conjunction with an accumulator provides a highly effective way to fully utilize the continuous operating nature of the cell stack. The accumulator serves as a temporary storage place for the ozone/oxygen gas mixture while the cassettes are being changed out, loaded with instruments or delivered to the operating room. The ozone fluid distribution system is designed so that the accumulator is continuously replenished with fresh ozone thus maintaining high ozone concentration for "on-demand" filling of the cassettes. The ozone distribution is controlled by a series of electrically actuated solenoid valves which are energized at the appropriate time by the system's on-board microcontroller. For the prototype, a three cassette design was implemented which most closely matches the cell stack ozone output. A side benefit of the portable cassette approach is the reduction of secondary contamination during transport of instruments to the operating room. An adaptation of these methods can

be used to sterilize endoscopes by flowing ozone gas through each channel.

Disinfection of medical wastes can also be effected using ozone. It is preferred that the medical waste be shredded and placed into a chamber where the shredded or particulate waste can be agitated. Intimate contact between the waste and ozone is achieved as ozone is passed through the chamber. The moisture content is varied by adding a saline solution to the waste mixture. Ozone concentration and pressure will improve the disinfection process in the same manner as described above.

DESTRUCTION OF AFLATOXINS IN GRAIN

Mycotoxins are naturally occurring chemical compounds that are produced by certain species of fungi (e.g., *Aspergillus*, *Fusarium*, *Penicillium*) which grow on organic materials such as grains. Mycotoxins include aflatoxins, fumonisin, cyclopiazonic acid, ochratoxin, patulin, secalonic acid A, and zearalenone. They are most often produced in the field under conditions of environmental stress (heat and drought). Aflatoxins (AFs) are the most commonly occurring and best known of the mycotoxins, and are also among the most potent. While the major forms, Aflatoxin B₁ and Aflatoxin G₁, are particularly noted as carcinogens (primarily for the liver), all of the aflatoxins can have adverse effects on virtually all other organ systems. These toxic effects can be either acute or chronic, depending on the level and duration of AF exposure and the species. Virtually all animals in the food chain can be affected by consumption of contaminated grain including humans, who can be exposed directly through grain handling and consumption or indirectly through consumption of contaminated livestock or livestock products (e.g., milk). As a result, aflatoxin contamination of grains such as corn and peanuts can create severe economic losses at all levels of food production, e.g., pre-harvest prevention, post-harvest treatment, down-grading or outright loss of contaminated grain, decreased productivity and increased loss of livestock, health care cost, etc.

Methods for detoxification of contaminated grain fall into three basic categories: physical, chemical or biological. Aflatoxins are generally resistant to physical methods of destruction (e.g., heat, irradiation), while mechanical and hand-sorting of infected kernels is time-consuming and expensive.

The inventor's research has shown that ozonation has promise as an effective means of aflatoxin destruction in solution where ozone is provided in high concentration and is a more effective reagent than dry O₃ gas. Preliminary evidence suggest that this method of gaseous ozone production can be applied effectively for the rapid destruction of aflatoxins. Ozone appears to immediately attack the C₈₋₉ double bond in aflatoxin B₁ and aflatoxin G₁ by electrophilic addition, while more slowly cleaving the coumarin moiety of aflatoxin B₂ and aflatoxin G₂. In addition, ozone is an effective sterilant and thus may reduce post-treatment growth of microorganisms during storage. It also may be capable of destroying pesticide residues (e.g., Captan, Dexton) and other undesirable contaminants.

It is anticipated that in addition to reducing aflatoxin contamination, this methodology may be useful for destruction of other mycotoxins (e.g., patulin, T₂ toxin, zearalenone) as well as acting as a sterilant to reduce post-treatment microbial growth. It is also believed that no new toxic compound are formed and that the nutritive value of the feed is not seriously affected by ozone treatment.

Two preferred systems are shown schematically in FIGS. 14 and 15. In FIG. 14, the ozone is forced under pressure through the bulk grain for the chosen duration of treatment. If necessary, the grain may easily be agitated (e.g., with an auger, from the top) to improve permeation of the O₃ throughout the sample. In a fully automated system, the appearance of residual ozone exiting the grain may be used as an indicator of completion of the treatment and used as a signal to shut down further ozone production.

In the second system (FIG. 15), the grain is moved from one storage bin to another with an auger. During the transit, the grain is moved past multiple ports for the input of the O₃ and thoroughly mixed with the gas. The auger speed can be adjusted to vary the rate of grain transfer and thus, the time of exposure of each portion of the grain to the input ozone. It is anticipated that this method will require less total contact time for effective treatment, and therefore less total ozone, than the first procedure.

In one example, approximately equal amounts of aflatoxin B₁, B₂, G₁ and G₂ were dissolved in a small amount of acetonitrile for further distribution in water. Gaseous ozone was generated electrochemically from a 25 cm² electrolyzer cell at a rate of 20 mg O₃/min and bubbled into the aflatoxin solutions for intervals of 15 seconds to 15 minutes. Upon termination of ozonation, an equal volume of chloroform was added immediately to the aqueous solution and the reaction products extracted by vortexing for 30 sec. The extracts were analyzed by HPLC for aflatoxin content. Aflatoxin B₁ and G₁ were totally degraded within 15 sec. aflatoxin B₂ and G₂ were slightly more resistant, requiring between 1-2.5 min for complete destruction.

In additional work, a standard corn-soybean meal feed mixture was contaminated with 750 ppb total aflatoxin as described above. When aliquots of the feed were simply spread on a tray and exposed to gaseous O₃ in a cabinet (3% O₃, -50% r.h.) for up to 1 hour, no decrease in the aflatoxin content was seen. However, exposing a similar aliquot of the mixture to a continuous flow-through of ozone (similar to the arrangement shown in FIG. 14) resulted in a measurable decrease of the total aflatoxin in as little as 5 minutes of treatment. While the variation was high in these initial trials (not shown), they also demonstrated the importance of the manner in which the ozone is presented to the grain to be treated.

SOIL TREATMENT PROCESS

Soil contaminated by various organic compounds (i.e., petroleum products, solvents) is one of today's most extensive environmental pollution problems. In addition, thousands of hazardous waste spills occur per year in the USA that require clean up under emergency response conditions. In many instances, it is standard practice to excavate and transport the contaminated soil to a suitable landfill or to incinerate the soil to remove the contaminant. Such practices are expensive, environmentally disruptive, require extensive permitting and only move the contamination from one location to another. On-site *in-situ* treatments of contaminated soil are safe and economical methods of permanently solving this problem. However, processes such as soil washing and incineration, that may be employed on site, produce solvents waste or ash that requires disposal.

Bioremediation is one of the most promising *in-situ* remediation methods currently being explored. This method uses either introduced or indigenous microorganisms to destroy or reduce the concentration of one or more organic wastes in a contaminated site. It has numerous advantages

over other remediation methods because the soil retains its ability to support plant growth. The high costs of traditional soil remediation methods (i.e., flushing, washing, excavation and disposal) are not incurred, and the contamination is destroyed, not just transferred elsewhere. However, one of the main difficulties of bioremediation is that many contaminants are biorefractory or are toxic to microorganisms so that the rate of contaminant removal is too slow to be practical.

The problem of biorefractory compounds in soil can be solved by applying a chemical oxidation step to the soil before biological treatment, to partially decompose the contaminants into intermediates that are more readily biodegraded. The present invention includes a method of using gaseous ozone as an agent for decomposing chemicals in contaminated soils. Ozone is an oxidant that is able to react with many organic chemicals. Experiments conducted with small scale soil columns indicate that ozone can degrade a broad range of contaminants in natural soil (e.g. polyaromatic and chlorinated hydrocarbons). These experiments suggest that it may be feasible to remediate soil contaminated with organic pollutants despite the presence of natural organic carbon matter, that exerts a significant ozone demand (i.e., consumes ozone before it reacts with the target pollutants). Past research has shown that it is difficult to transport ozone in saturated soils. However, this observation should not be translated to ozone venting which is the transport of gaseous ozone in unsaturated soils. The concentration of ozone in the gas phase is orders of magnitude higher than in aqueous solutions and the flow rates than can be achieved are much higher. Furthermore the half life of ozone in water is 20 minutes at best, whereas ozone gas has a half life of 24 hours.

The electrochemical method of ozone generation has a number of critical advantages over the corona discharge process for ozone venting applications. These are highlighted below.

1. High concentration. The concentration of ozone generated by this method (15–20 wt %) is substantially higher than is obtained by the conventional method. Electrochemical ozonizers should provide enhanced rates of soil decontamination particularly in heavily contaminated soil.
2. Self pressurization. A substantial build-up in gas pressure is achieved with not energy penalty and without the need for a compressor to deliver the ozone underground. This should enhance ozone flow in soils of low gas permeability and will increase ozone solubility.
3. Compact modular design. Electrochemical systems can be easily skid or trailer mounted for field applications.
4. Lower capital costs. Electrochemical ozonizers are projected to cost less than the corona discharge units.

These advantages enable successful and economically viable implementation of ozone venting. The overall aim is to develop in-situ ozonation, not to completely mineralize the compounds, but to produce oxidation by-products which are more bioavailable and biodegradable by the native consortia of microorganisms. The commercial attractiveness of in-situ ozone venting is that it is complementary to existing in-situ techniques and in some cases can be used to overcome their limitations. While bioremediation and soil vapor extraction (SVE) are leading in-situ technologies, they both have limitations. In-situ bioremediation is often too slow to be practical for compounds that are not readily biodegraded. In-situ SVE is not effective for the removal of non-volatile and semi-volatile organics.

Ozone itself can react selectively with certain dissolved organics. In the case of the highly chlorinated aromatic compounds, chlorinated carboxylic acids and ketones intermediates may result. These compounds are rapidly hydrolyzed in water to form carbon dioxide and HCl. Ozone decomposition in water (promoted by UV light or H_2O_2/HO_2) leads to the formation of hydroxyl radicals.

For compounds of intermediate or low reactivity with ozone directly (e.g., trichloroethylene), the reaction with hydroxyl radicals generated by the degradation of ozone is primarily responsible for the degradation of the compound in soil. Only the compounds that are extremely reactive with ozone (e.g. PAHs) does the reaction with molecular ozone appear to be the more important degradation pathway. It was found that the more hydrophobic PAHs (e.g. chrysene) react more slowly than would be expected on the basis of their reactivity with ozone, suggesting that partitioning of the contaminant into the soil organic matter may reduce the reactivity of the compound. Even so, after 4 hours exposure to ozone, the chrysene concentration in a contaminated Metea soil was reduced from 100 mg/kg to 50 mg/kg. Under the same conditions, greater than 90% removal of phenanthrene and pyrene could be achieved with an ozonation time of 1 hour.

In Ottawa sand, it was observed that in dry soil, approximately 65% of the naphthalene was removed using air venting for 37 hours; this resulted in a residual naphthalene concentration of 23.2 mg/kg soil. Air stripping (for 23 hours), followed by ozone-venting (for 3.2 hours) resulted in a naphthalene residual of 0.65 mg/L (approx. 99.7% removal). Similar results were observed in moist soil when ozone venting was applied; the residual naphthalene concentration obtained was approximately two orders of magnitude lower than that obtained when using air venting alone. Experiments have been conducted to study the transport of ozone in soil columns using a number of geological materials. Ozone is readily transported through columns packed with Ottawa sand. In this case, there was a rapid initial breakthrough of ozone (within 1.5 pore volumes), however, complete breakthrough was not achieved until nearly 5 pore volumes had passed through the column.

Work has also been conducted with a Metea soil. Although the ozone demand exerted by the Metea soil is greater than that of the Ottawa sand, breakthrough in a 10 cm column was observed in approximately 600 pore volumes. For Borden sand, 90% ozone breakthrough was achieved in a 30 cm column in ca. 300 pore volumes. All the geological material studied exerted a limited (finite) ozone demand, i.e., the rate of ozone degradation in soil columns is very slow after the ozone demand is met. Ottawa sand exerts little ozone demand (<0.01 mg O_3 /g sand). For Metea soil the ozone demand is approximately 1.4 mg O_3 /g soil and the ozone demand for Borden sand is approximately 2 mg O_3 /g sand. Once the initial ozone demand is met ozone should not be rapidly degraded once injected into soil.

The objective of in-situ ozonation is not to completely mineralize the compounds but to produce oxidation by-products which are more bioavailable and biodegradable by the native consortia of microorganisms. While some lower molecular weight compounds may be completely mineralized by ozone, many of the compounds are not mineralized rapidly by ozone. It is true that ozone would kill many soil organisms. However, there is evidence that shows that microorganisms are mobile in the subsurface. This suggests that the reinoculation of microorganisms into the subsurface would be possible, certainly, in sandy or other coarse grained deposits.

WASTEWATER TREATMENT

The ozone produced by the present invention may be used for numerous applications. One example is the treatment of waste water. Such waste water treatment may be performed with or without the use of ultraviolet high. The ultraviolet light radiation is capable of producing hydroxyl radicals from ozone fed into a waste water stream.

OTHER APPLICATIONS

The present invention further includes a method of washing laundry without detergent. Laundry is placed into a vessel that is substantially sealed and filled with water. A gas having an ozone concentration greater than about 7 weight percent into the water is then introduced and bubbled into the water. The ozone becomes dissolved in the water and contacts the laundry. This contact is continued for a period of time sufficient to allow the ozone to clean the laundry. The exact length of time will be effected by the ozone concentration and the degree of contamination on the laundry. When the laundry is clean, the ozone supply is shut off and the remaining ozonated water is discarded from the vessel. Because there may be some residual ozone on the laundry, the laundry is allowed to sit for a short period of a few minutes so that the ozone can decompose prior to opening the vessel. The clean laundry is then removed from the vessel for drying. Because the cleaning rate is effected by the ozone concentration, it is preferred that the ozone be generated in an electrochemical cell.

Another application of the highly concentrated ozone production of the present invention is in the poultry industry. Present hatching technology proscribes the use of large square boxes in which eggs are incubated and hatched. These boxes become extremely contaminated with organic waste as the chicks break through the shell. Organic material from inside the egg becomes coated on the walls of the box and provides a source of bacterial growth. The concentrated ozone gas of the present invention would provide a means for disinfecting these boxes for reuse in the hatching process.

A particular advantage of the cells according to the present invention is that the ozonizers may be made compact and therefore are useful in such applications as swimming pool sanitization, control of bio-fouling in air conditioning systems, cooling towers, industrial waste treatment applications, i.e., such as phenol, pesticide, cyanide, dye waste, and heavy metals.

Further uses include in bottling and maintaining potable water quality in remote sites, reprocessing aquaria water, odor control or disinfection of sewage. Many of these applications are not currently utilizing ozone due to the high cost of ozonizers heretofore known, the associated cost of air or oxygen preparation and the low concentration of ozone output.

It will be understood that certain combinations and sub-combinations of the invention are of utility and may be employed without reference to other features or sub-combinations. This is contemplated by and is within the scope of the present invention. Many possible embodiments may be made of this invention without departing from the spirit and scope thereof. It is to be understood that all matters herein above set forth or shown in the accompanying drawings are to be interpreted as illustrative and not in any limiting sense.

While the foregoing is directed to the preferred embodiments, the scope thereof is determined by the claims which follow:

What is claimed is:

1. A method of sterilizing a biologically contaminated instrument comprising the steps of:
 - placing the biologically contaminated instrument into an enclosed chamber; then
 - evacuating air from the enclosed chamber; then
 - maintaining humidity within the enclosed chamber;
 - introducing a gas having an ozone concentration greater than about 7 weight percent into contacting the instrument with the gas for a period of time sufficient to allow the ozone to sterilize contaminants on the instrument;
 - removing the gas from the chamber; and
 - removing the sterilized instrument.
2. The method of claim 1 further comprising the step of: pressurizing the gas within the enclosed chamber.
3. The method of claim 2, wherein the enclosed chamber volume is heated by means of an exterior heating blanket.
4. The method of claim 3, wherein the enclosed chamber having an exterior heating blanket comprises one or more chambers having exterior heating blankets.
5. The method of claim 4, wherein the one or more chambers having exterior heating blankets are part of a main sterilization system.
6. The method of claim 5, wherein the one or more chambers having exterior heating blankets are capable of being removed from the main sterilization system.
7. The method of claim 6, wherein the removable chambers having exterior heating blankets are portable.
8. The method of claim 6, wherein the main sterilization system comprises an accumulator that stores an ozone/oxygen gas mixture.
9. The method of claim 8, wherein the accumulator is in fluid communication with an electrochemical ozone reactor and with the one or more removable chambers having exterior heating blankets.
10. The method of claim 2, wherein the ozone is generated under pressure by an electrochemical cell comprising:
 - an anode disposed in an anodic chamber comprising a substrate and a catalyst coating, wherein the substrate is selected from the group consisting of porous titanium, titanium suboxides, tantalum, hafnium and niobium, and wherein the catalyst coating is selected from the group consisting of lead dioxide, boron-doped diamond, platinum-tungsten alloys or mixtures, glassy carbon and platinum;
 - a cathode disposed in a cathodic chamber; and
 - a proton exchange membrane having a first side in contact with the cathode and a second side in contact with the anodic catalyst layer.
11. The method of claim 10 wherein the cathode is compatible with liquid phase cathodic depolarizers, wherein the cathode is selected from the group consisting of flow-by electrodes, flow-through electrodes, packed bed electrodes, and fluidized bed electrodes.
12. The method of claim 10, wherein the proton exchange membrane is comprised of a perfluorinated sulphonic acid polymer.
13. The method of claim 11 wherein the cathode is a gas diffusion electrode comprising a polytetrafluoroethylene-bonded, semi-hydrophobic catalyst layer supported on a hydrophobic gas diffusion layer, wherein the catalyst layer is comprised of a proton exchange polymer, polytetrafluoroethylene polymer and a metal selected from the group consisting of platinum, palladium, gold, iridium, nickel and mixtures thereof, and wherein the gas diffusion layer has a

carbon cloth or carbon paper fiber impregnated with a sintered mass derived from fine carbon powder and a polytetrafluoroethylene emulsion.

14. The method of claim 1 wherein the ozone is generated in a humidified form by an electrochemical cell comprising:
 5 an anode disposed in an anodic chamber comprising a substrate and a catalyst coating, wherein the substrate is selected from the group consisting of porous titanium, titanium suboxides, tantalum, hafnium and niobium, and wherein the catalyst coating is selected
 10 from the group consisting of lead dioxide, boron-doped diamond, platinum-tungsten alloys or mixtures, glassy carbon and platinum;
 a cathode disposed in a cathodic chamber; and
 a proton exchange membrane having a first side in contact
 15 with the cathode and a second side in contact with the anodic catalyst layer.

15. The method of claim 14 wherein the cathode is compatible with liquid phase cathodic depolarizers, wherein the cathode is selected from the group consisting of flow-by
 20 electrodes, flow-through electrodes, packed bed electrodes, and fluidized bed electrodes.

16. The method of claim 14, wherein the proton exchange membrane is comprised of a perfluorinated sulphonic acid
 25 polymer.

17. The method of claim 15 wherein the cathode is a gas diffusion electrode comprising a polytetrafluoroethylene-bonded, semi-hydrophobic catalyst layer supported on a hydrophobic gas diffusion layer, wherein the catalyst layer is
 30 comprised of a proton exchange polymer, polytetrafluoroethylene polymer and a metal selected from the group consisting of platinum, palladium, gold, iridium, nickel and mixtures thereof, and wherein the gas diffusion layer has a carbon cloth or carbon paper fiber impregnated with a
 35 sintered mass derived from fine carbon powder and a polytetrafluoroethylene emulsion.

18. The method of claim 1, wherein the biologically contaminated instrument is a medical tool, medical
 40 apparatus, dental tool or dental apparatus.

19. The method of claim 18, wherein the biologically contaminated instrument is an endoscope.

20. The method of claim 19, wherein sterilizing the endoscope comprises flowing ozone gas through each channel
 45 of the endoscope.

21. The method of claim 1, wherein the instrument is biologically contaminated with spores.

22. The method of claim 1, wherein a sterilization cycle of 65 minutes is achieved.

23. The method of claim 1, wherein a sterilization cycle
 50 of between 30 and 90 minutes is achieved.

24. The method of claim 1, further comprising:
 with drawing the gas from the enclosed chamber at a rate sufficient to maintain an average ozone concentration in the chamber that is greater than about 4 weight percent.

25. The method of claim 1, wherein the enclosed chamber has an exterior heating blanket.

26. The method of claim 1 further comprising the step of: pressurizing the gas within the enclosed chamber to a
 pressure greater than about 20 psi.

27. The method of claim 1, further comprising: maintaining an open container of water inside the chamber.

28. The method of claim 1, further comprising: providing the ozone-containing gas in a near water saturated state.

29. The method of claim 1, wherein the ozone-containing
 15 gas is a humidified gas.

30. The method of claim 1, wherein the ozone-containing gas is generated in a humidified form.

31. The method of claim 1, wherein the ozone-containing gas is generated in a humidified form by an electrochemical
 20 cell.

32. A method of sterilizing a biologically contaminated instrument comprising the steps of:

placing the biologically contaminated instrument into an enclosed chamber;

evacuating air that is essentially free of ozone from the enclosed chamber;

maintaining humidity within the enclosed chamber;

30 introducing a gas having an ozone concentration greater than about 7 weight percent into the chamber;

contacting the instrument with the gas for a period of time sufficient to allow the ozone to sterilize contaminants on the instrument;

35 removing the gas from the chamber; and

removing the sterilized instrument.

33. A method of sterilizing a biologically contaminated instrument comprising the steps of:

40 placing the biologically contaminated instrument into an enclosed chamber; then

evacuating air from the enclosed chamber to draw a vacuum; then

45 maintaining humidity within the enclosed chamber;

introducing a gas having an ozone concentration greater than about 7 weight percent into the chamber;

contacting the instrument with the gas for a period of time sufficient to allow the ozone to sterilize contaminants on the instrument;

50 removing the gas from the chamber; and

removing the sterilized instrument.

* * * * *

UNITED STATES PATENT AND TRADEMARK OFFICE
CERTIFICATE OF CORRECTION

PATENT NO. : 6,387,241 B1
DATED : May 14, 2002
INVENTOR(S) : Oliver J. Murphy and G. Duncan Hitchens

Page 1 of 1

It is certified that error appears in the above-identified patent and that said Letters Patent is hereby corrected as shown below:

Column 1,

Line 15, delete “and”; and

Line 16, after “National Science Foundation”, insert -- , and DAMD17-91-C-1105 awarded by the Army --.

Signed and Sealed this

Twelfth Day of November, 2002

Attest:

A handwritten signature in black ink, appearing to read "James E. Rogan", written over a horizontal line.

Attesting Officer

JAMES E. ROGAN
Director of the United States Patent and Trademark Office