



US006198983B1

(12) **United States Patent**
Thrash et al.(10) **Patent No.:** **US 6,198,983 B1**
(45) **Date of Patent:** **Mar. 6, 2001**(54) **TABLE-DRIVEN SOFTWARE ARCHITECTURE FOR A STITCHING SYSTEM**(75) Inventors: **Patrick J. Thrash**, Huntington Beach; **Jeffrey L. Miller**, Hermosa Beach; **Ken Pallas**, Lakewood, all of CA (US); **Robert C. Trank**, Belvedere, IL (US); **Rhoda Fox**, Cherry Valley, IL (US); **Mike Korte**, Rockford, IL (US); **Richard Codos**, Warren, NJ (US); **Alexandre Korolev**, Scotch Plains, NJ (US); **William Collan**, Englishtown, NJ (US)

4,285,293	8/1981	Martling	112/281
4,331,091	5/1982	Parker et al.	112/475
4,429,364	1/1984	Maruyama et al.	700/137
4,446,520	5/1984	Shigeta et al.	700/137
4,481,507	11/1984	Takuguchi et al.	340/649
4,503,788	3/1985	Giannuzzi et al.	112/470.06
4,506,611	3/1985	Parker et al.	112/79
4,702,185 *	10/1987	Hanyu et al.	112/121.14
4,776,291	10/1988	Tajima et al.	112/98
4,786,343	11/1988	Hertzbert	156/93
4,798,152	1/1989	Simons et al.	112/470.05
4,815,404	3/1989	Ellermann et al.	112/470.01
4,825,784 *	5/1989	Nomoto	112/103
4,843,986	7/1989	Kozuka et al.	112/163

(List continued on next page.)

(73) Assignee: **McDonnell Douglas Corporation**, St. Louis, MI (US)

(*) Notice: Subject to any disclaimer, the term of this patent is extended or adjusted under 35 U.S.C. 154(b) by 0 days.

(21) Appl. No.: **08/995,843**(22) Filed: **Dec. 22, 1997**(51) **Int. Cl.**⁷ **D05C 5/02**(52) **U.S. Cl.** **700/138**; 700/136; 700/137; 700/181; 700/182; 700/183; 112/470.05; 112/475.18; 112/254(58) **Field of Search** 700/137, 138, 700/183, 182, 136, 181, 184; 112/470.05, 281, 475.18, 475.01, 254, 470.13, 302, 155, 475.08(56) **References Cited****U.S. PATENT DOCUMENTS**

3,312,184	4/1967	Cash	112/118
3,515,080	6/1970	Ramsey	112/470.13
3,765,349 *	10/1973	Gerber	112/254
4,067,276	1/1978	Mohilo et al.	112/220
4,092,938	6/1978	Coughenour	112/457
4,104,976	8/1978	Landau, Jr.	112/470.02

OTHER PUBLICATIONS

Chen et al., A new generation of intelligent punching environment for computerized embroidery tools with Artificial Intelligence, Proceedings., Sixth International Conference on, pp. 692-695, 1994.*

Carvalho et al., "Measurements And Feature Extraction In High-Speed Sewing", IEEE., pp. 961-966, 1997.*

Primary Examiner—William Grant*Assistant Examiner*—McDieunel Marc(74) *Attorney, Agent, or Firm*—Westerlund & Powell, P.C.; Robert A. Westerlund; Raymond H. J. Powell, Jr.(57) **ABSTRACT**

Native code for a CNC stitching machine is generated by generating a geometry model of a preform; generating tool paths from the geometry model, the tool paths including stitching instructions for making stitches; and generating additional instructions indicating thickness values. The thickness values are obtained from a lookup table. When the stitching machine runs the native code, it accesses a lookup table to determine a thread tension value corresponding to the thickness value. The stitching machine accesses another lookup table to determine a thread path geometry value corresponding to the thickness value.

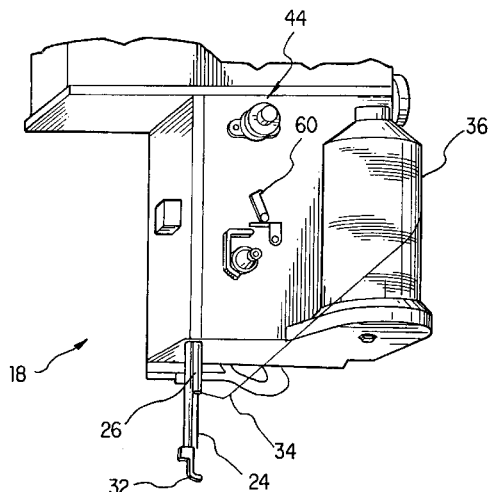
24 Claims, 7 Drawing Sheets

U.S. PATENT DOCUMENTS

4,873,931	10/1989	Takagi et al.	112/470.01	5,379,226	1/1995	Shigeta	700/137
4,876,973	10/1989	Marrache et al.	112/470.13	5,383,417	1/1995	Norrid	112/278
4,899,287	2/1990	Hulshoff et al.	700/136	5,392,724	2/1995	Kurono et al.	112/102.5
4,917,756	4/1990	Cahuzac et al.	156/429	5,473,535	* 12/1995	Shigeta et al.	700/138
4,992,317	2/1991	Chess et al.	428/102	5,474,000	* 12/1995	Mizuno et al.	112/102.5
5,010,834	* 4/1991	Iimuro et al.	112/302	5,474,001	12/1995	Tajima et al.	112/102.5
5,218,916	6/1993	Kurono et al.	112/102.5	5,510,994	* 4/1996	Tsonis et al.	700/137
5,227,976	* 7/1993	Hayakawa	700/138	5,515,798	5/1996	Cahuzac	112/470.12
5,239,475	8/1993	Shigeta et al.	700/137	5,537,945	7/1996	Sugihara et al.	112/470.06
5,287,820	2/1994	Stutznacker	112/117	5,543,005	* 8/1996	Monget et al.	156/93
5,299,519	4/1994	Hirabayashi	112/456	5,563,795	* 10/1996	Futamara et al.	700/138
5,311,439	* 5/1994	Hayakawa et al.	700/138	5,703,782	* 12/1997	Dundorf	700/182
5,341,755	8/1994	Kawasaki	112/163	5,915,317	* 6/1999	Thrash et al.	112/470.13
5,343,401	* 8/1994	Goldberg et al.	700/138				

* cited by examiner

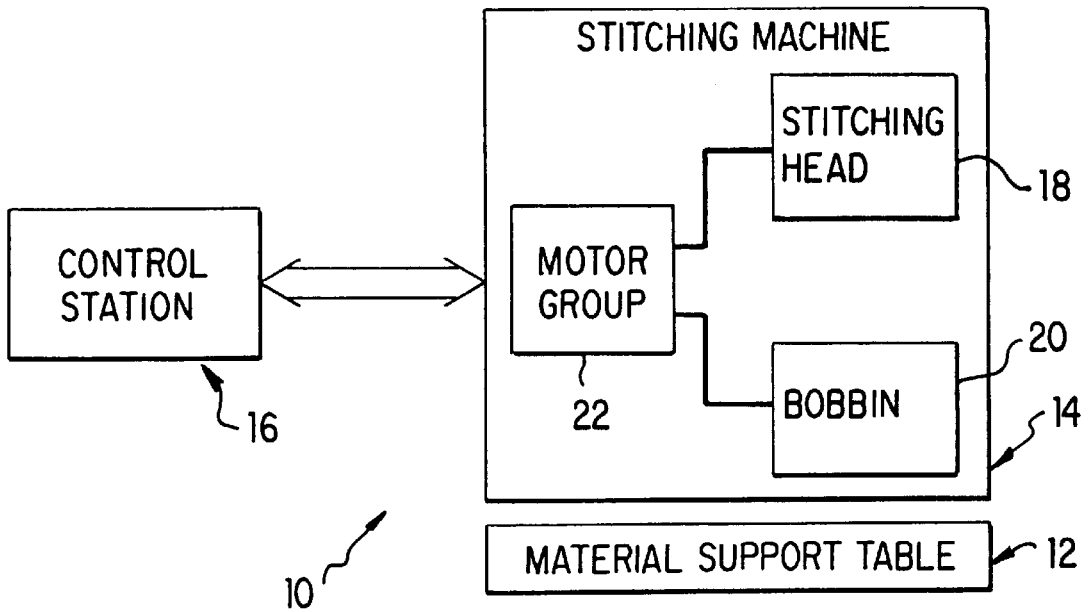

FIG. 1

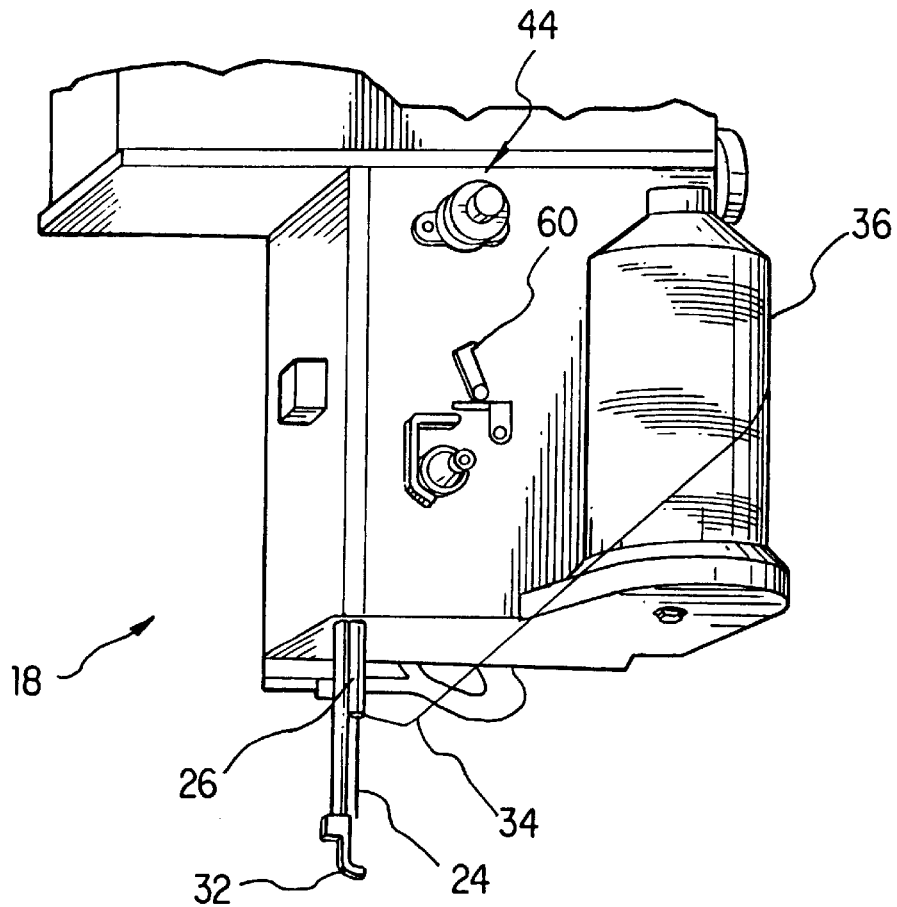

FIG. 2

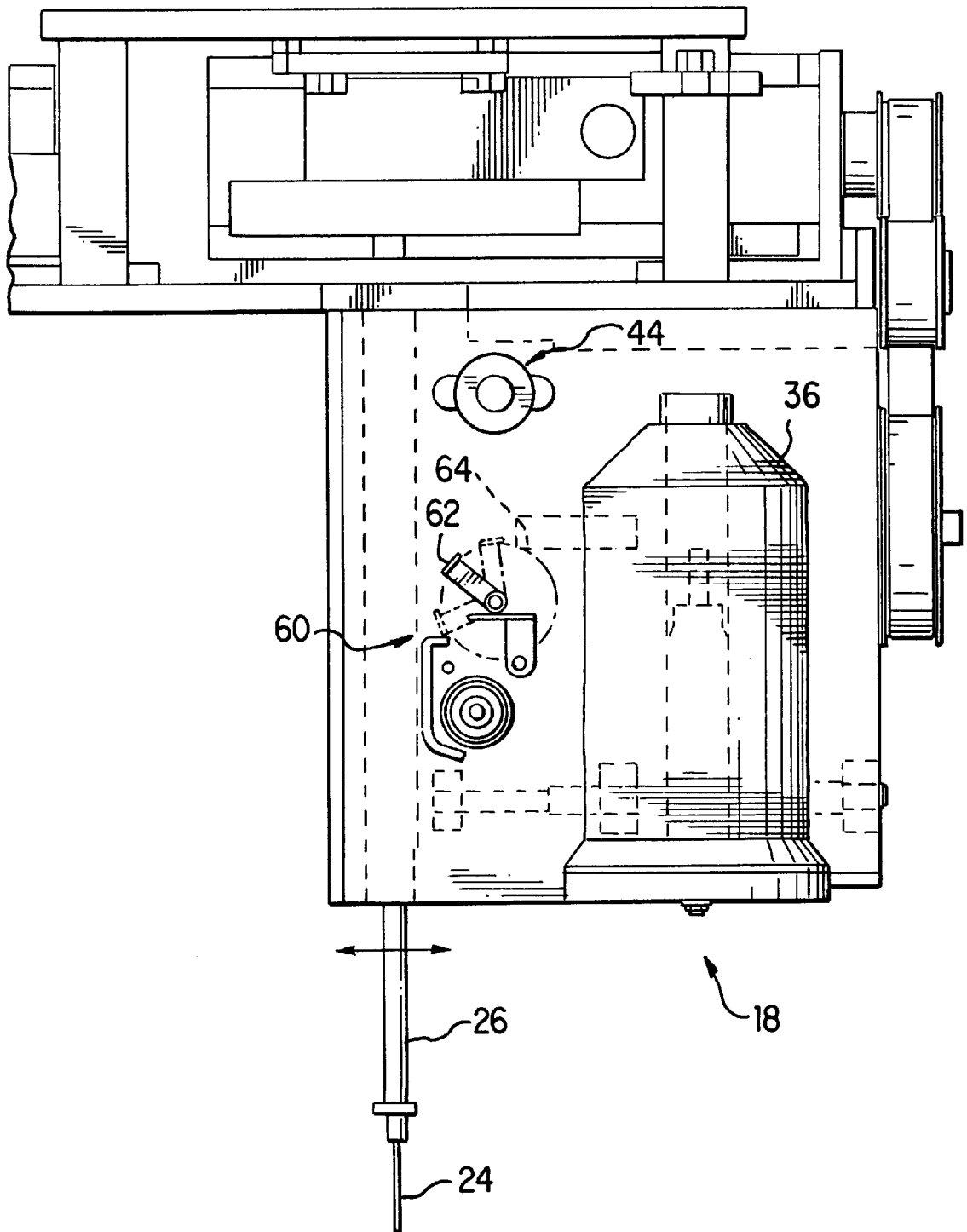

FIG. 4

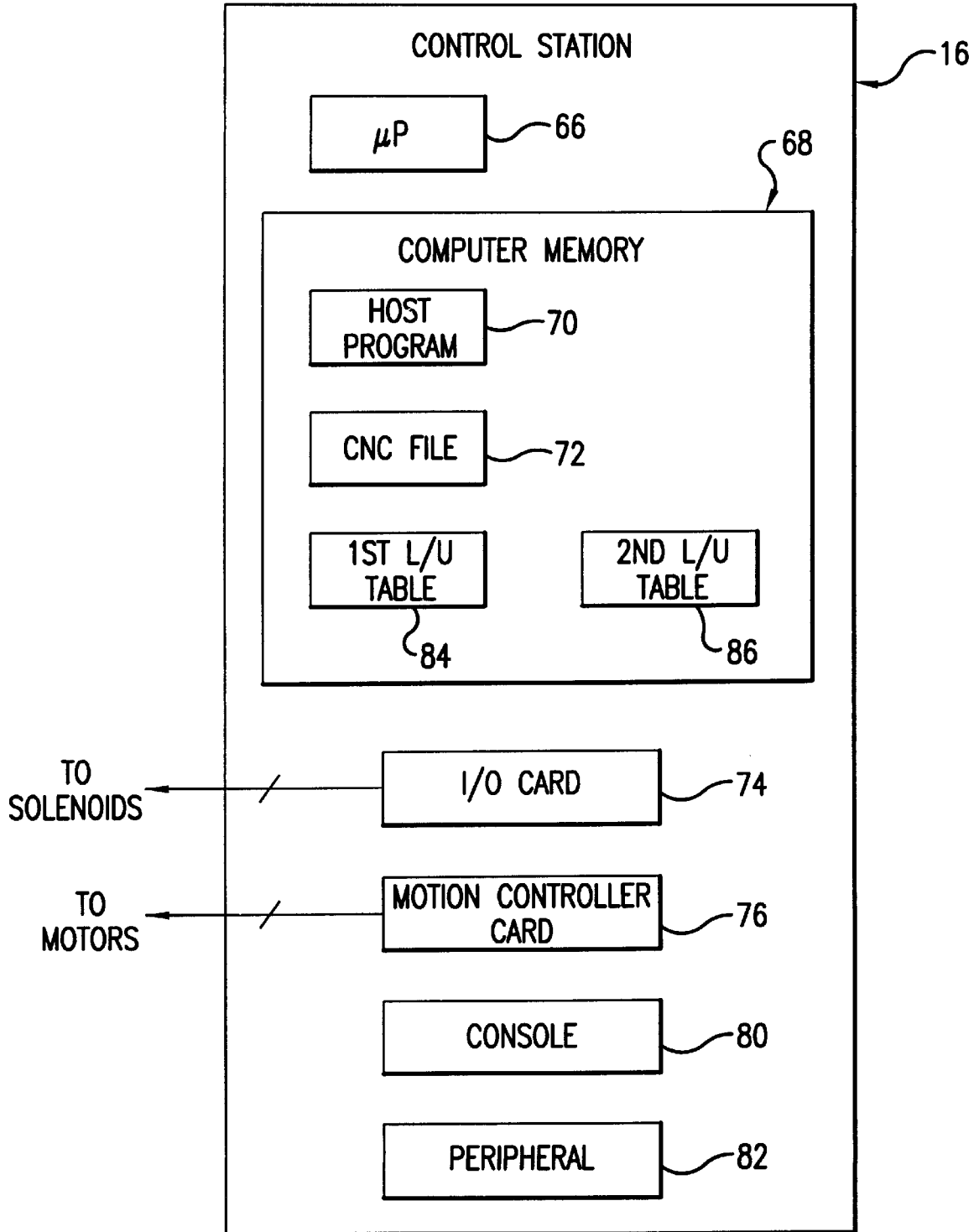

FIG.5

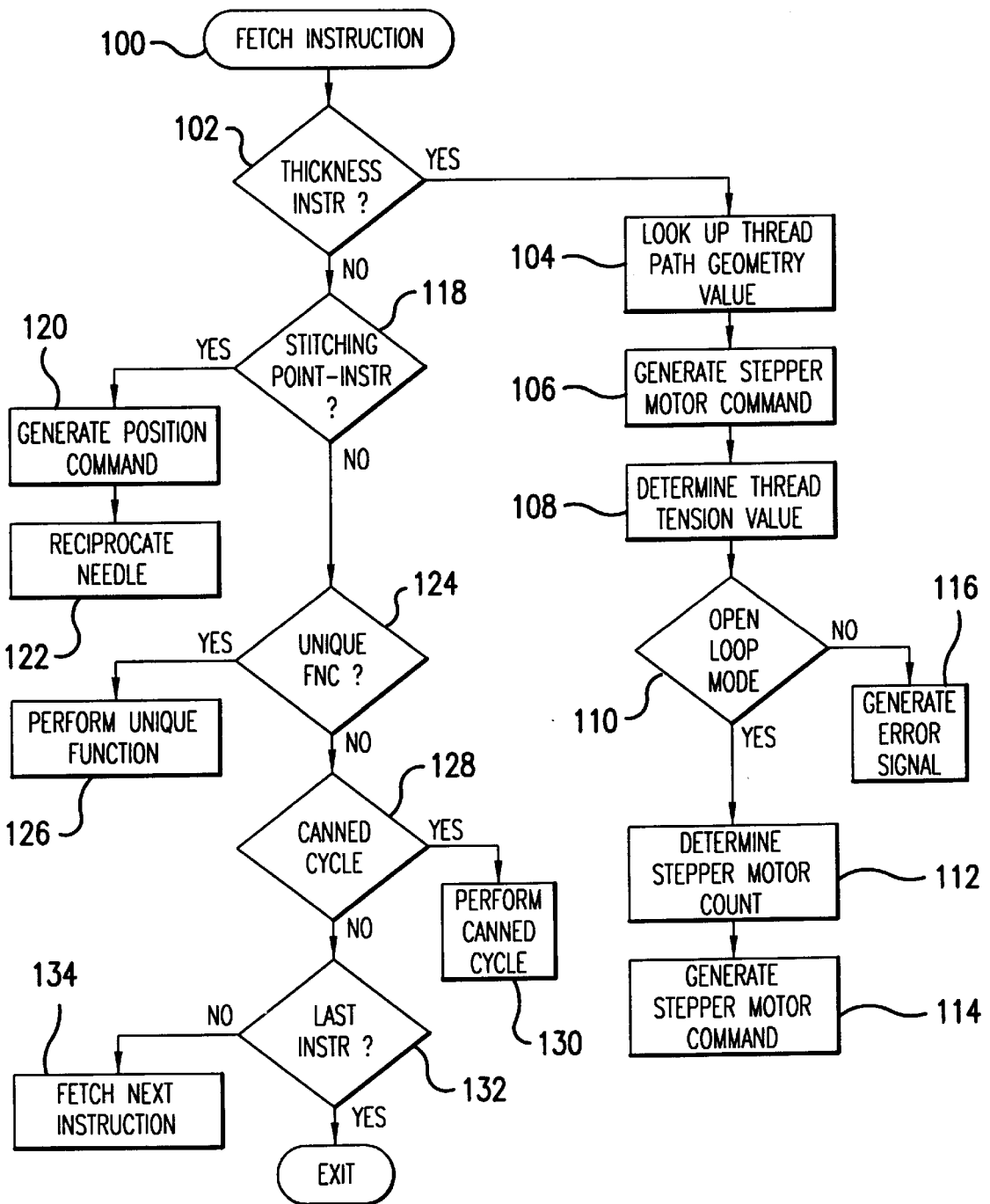

FIG. 6

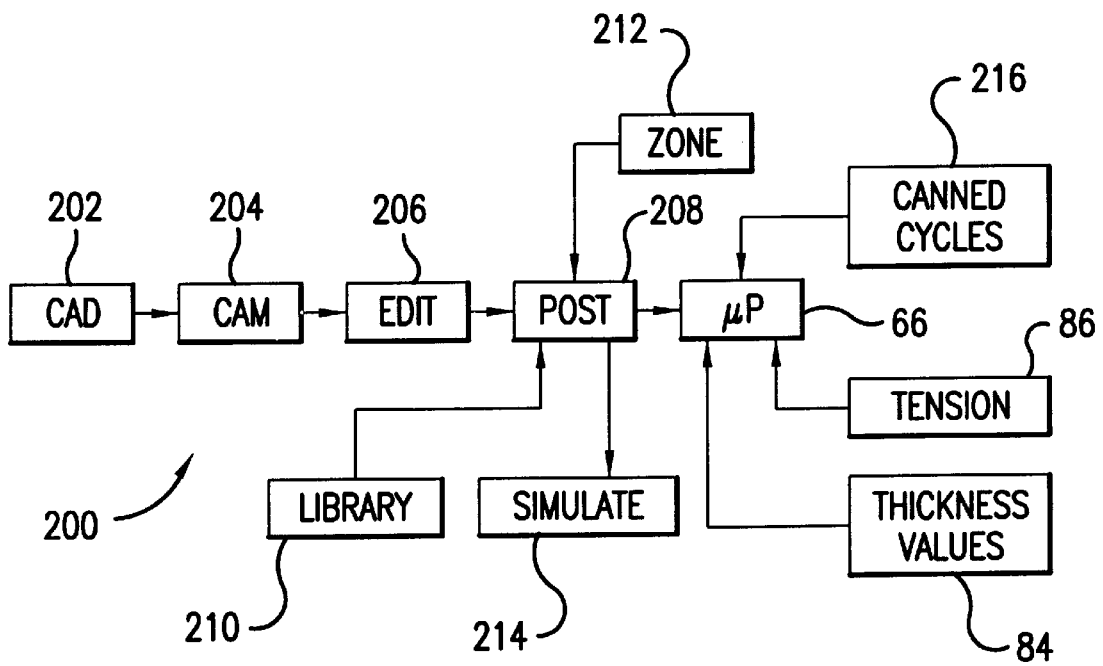

FIG. 7

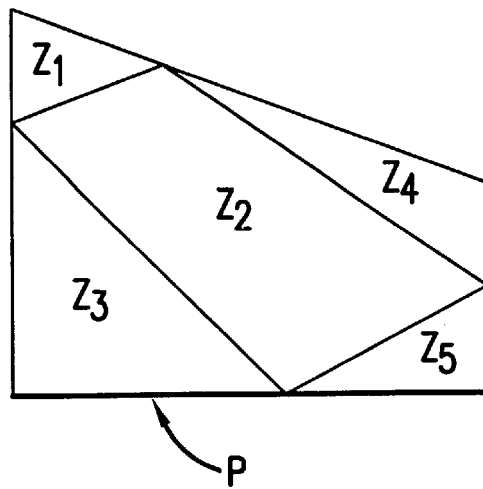

FIG.8

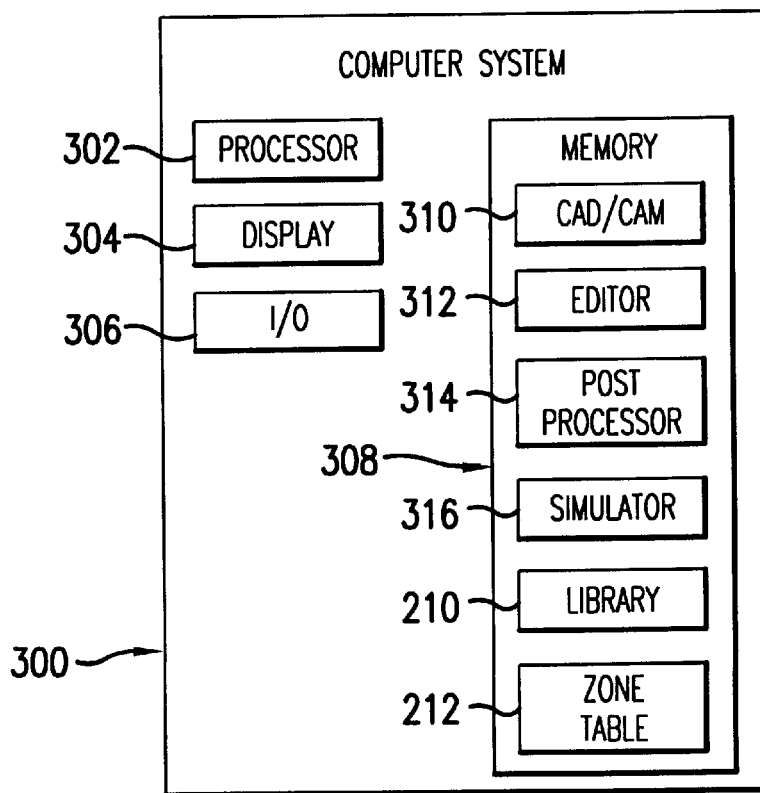

FIG.9

TABLE-DRIVEN SOFTWARE ARCHITECTURE FOR A STITCHING SYSTEM

This invention was made under contract no. NAS1-18862 awarded by NASA. The Government has certain rights in this invention.

BACKGROUND OF THE INVENTION

This invention relates to textile manufacturing. More specifically, this invention relates to a software architecture for a computer numerically controlled stitching system.

Large aircraft structures such as wing covers are now being fabricated from textile composites. The textile composites are attractive because of their potential for lowering the cost of fabricating the large aircraft structures. Cutting pieces of fabric and stitching the fabric pieces together have the potential of being less expensive than cutting sheets of aluminum, drilling holes in the aluminum sheets, removing excess metal and assembling metal fasteners.

The wing cover can be made from a carbon-fiber textile composite. Sheets of knitted carbon-fiber fabric are cut out into pieces having specified sizes and shapes. Fabric pieces having the size and shape of a wing are laid out first. Several of these pieces are stacked to form the wing cover. Additional pieces are stacked to provide added strength in high stress areas. After the fabric pieces are arranged in their proper positions, the pieces are stitched together to form a wing preform. Secondary details such as spar caps, stringers and intercostals are then stitched onto the wing preform. Such a wing preform might have a thickness varying between 0.05 inches and 1.5 inches. The wing preform is quite large, and its surface is very complex, usually a compound contoured three-dimensional surface.

The stitched wing preform is transferred to an outer mold line tool that has the shape of an aircraft wing. Prior to the transfer, a surface of the outer mold line tool is covered with a congealed epoxy-resin. The tool and the stitched wing preform are placed in an autoclave. Under high pressure and temperature, the resin is infused into the stitched preform and cured. Resulting is a cured wing cover that is ready for assembly into a final wing structure.

For textile composite technology to be successful, two barriers must be addressed: cost and damage tolerance. Damage tolerance is achieved by making high quality, closely-spaced stitches on the wing preform. The high quality, closely-spaced stitches add a third continuous column of material to the wing preform. If thread tension is not proper, a large number of stitches on the preform will not be of sufficient quality and will reduce the damage tolerance. Improper thread path geometry might also degrade the quality of the stitches and, therefore, reduce the damage tolerance.

Even though the stitches are made by a stitching machine that is computer numerically controlled ("CNC"), it is difficult to make stitches having the high quality required for the wing preform. On a compound, contoured three-dimensional surface, thread tension and thread path geometry must be constantly adjusted for an exceedingly large number of stitches. The CNC stitching machine might make eight to ten stitches per inch, in rows that might be spaced 0.1 inches to 0.5 inches apart, over a surface that might be longer than forty feet and wider than eight feet. The total number of stitching points on the wing preform might exceed 1.5 million.

Much manual labor is required. Because the wing preform has many regions of differing thickness, a machine operator

must constantly stop the stitching machine when a new region is about to be stitched, adjust the thread tension and possibly the thread path geometry, and restart the stitching machine. Of course, the CNC stitching machine has multiple stitching heads. At any given time, two or more stitching heads might be stitching different regions having different thicknesses. Whenever one of the stitching heads enters a new region, the stitching machine must stop and the thread tension and perhaps the thread path geometry of the stitching head entering the new region must be adjusted. Resulting is a large number of instances in which the stitching machine must be stopped, the thread tension and thread path geometry adjusted, and the stitching machine restarted.

Additionally, the operator must know when to stop the machine and make the adjustments, or the operator must be prompted to stop the stitching machine and make the adjustments. Either way, the operator must pay constant attention while the wing preform is being stitched. That too is difficult, considering the large number of stitches that must be made.

Moreover, generating the code for the CNC stitching machine would take a programmer thousands of hours. Not only would generating the code take a long time, but it would also be subject to human error.

The manual labor increases the time and cost of manufacturing the wing preform, and it potentially reduces damage tolerance. Based on the foregoing, it can be appreciated that there presently exists a need for a software architecture that allows for complete operation, from path generation to control of the stitching process. As will become apparent hereinafter, the present invention fulfills this need.

SUMMARY OF THE INVENTION

The invention can be regarded as a method of using a computer to generate native code for a stitching machine. The method comprises the steps of using the computer to generate a geometry model; using the computer to generate tool paths from the geometry model, the tool paths including a first plurality of instructions for making stitches; and using the computer to generate a second plurality of instructions indicating thickness values. The instructions of the second plurality are inserted between the instructions of the first plurality.

The invention can also be regarded as a computer system for generating native code for a CNC stitching machine. The system comprises means for generating a geometry model; means for generating tool paths from the geometry model, the tool paths including a first plurality of instructions for making stitches; a zone table for determining thickness values; and means for accessing the zone table to generate a second plurality of instructions indicating the thickness values. The instructions of the second plurality are inserted between the instructions of the first plurality.

The invention can also be regarded as a method of using a processor to automatically adjust thread tension in a stitching head of a stitching machine. The stitching head includes a servo for setting the thread tension. The method comprises the steps of: using the processor to access data indicating a thickness value; using the processor to determine a thread tension value corresponding to the thickness value; and commanding the servo to the thread tension value.

The invention can also be regarded as an article of manufacture comprising computer memory; and data encoded in the computer memory. The data includes instruc-

tions for instructing a computer to access a lookup table for thickness values, access thread tension values corresponding to the thicknesses values, and generate servo commands corresponding to the thread tension values.

BRIEF DESCRIPTION OF THE DRAWINGS

The above and other objects, features and advantages of the present invention will become apparent from the following detailed description taken in conjunction with the accompanying drawings, in which:

FIG. 1 is a block diagram of a stitching system including a stitching machine and a control station;

FIG. 2 is a perspective view of a stitching head for the stitching machine;

FIG. 3 is a side view of the stitching head;

FIG. 4 is a different side view of the stitching head;

FIG. 5 is a block diagram of the control station;

FIG. 6 is a flowchart of a method of operating the stitching head;

FIG. 7 is diagram of a software architecture for generating code for the stitching system;

FIG. 8 is a schematic diagram of a preform having variable thickness; and

FIG. 9 is a block diagram of a computer system for generating the code.

DETAILED DESCRIPTION OF THE INVENTION

While the present invention is described herein with reference to the illustrative embodiments for particular applications, it should be understood that the invention is not limited thereto. Those having ordinary skill in the art and access to the teachings provided herein will recognize additional modifications, applications, and embodiments within the scope thereof and additional fields in which the present invention would be of significant utility.

FIG. 1 shows an automated stitching system 10 including a material support table 12, a stitching machine 14 and a control station 16. The material support table 12 provides a surface for supporting a preform. The surface of the material support table 12 can be tailored to the desired shape of the preform. For example, the material support table 12 can provide a flat two-dimensional surface, a contoured three-dimensional surface, or a compound, contoured three-dimensional surface.

The stitching machine 14 includes a stitching head 18 and bobbin 20 operable to make a plurality of stitches in the preform. The stitching machine 14 further includes a motor group 22 for moving the stitching head 18 and the bobbin 20 with respect to the material support table 12. The motor group 22 includes a first servo-controlled motor for positioning the stitching head 18 with respect to an x-axis and a second servo-controlled motor for positioning the stitching head 18 with respect to a y-axis. The motor group 22 could also include a third servo-controlled motor for positioning the stitching head 18 with respect to a z-axis and a fourth servo-controlled motor for positioning the stitching head 18 with respect to a rotational c-axis. The third and fourth servo-controlled motors would allow the stitching machine 14 to stitch a preform having a compound, contoured three-dimensional surface. The motor group 22 also includes servo-controlled motors for moving the bobbin 20 synchronously with the stitching head 18. Of course, the motor group 22 could include additional servo-controlled motors if additional degrees of freedom are desired.

FIGS. 2, 3 and 4 show the stitching head 18 in greater detail. The stitching head 18 includes a needle 24, a needle bar 26, and a needle drive mechanism 28 such as a slider crank mechanism for vertically extending and rotating the needle bar for positive and negative reciprocation of the needle 24. The needle drive mechanism 28 is driven by a motor 30. A presser foot 32 applies pressure to the preform and guides the needle 24. A constant-velocity mechanism (not shown) allows the needle 24 to move relative to the preform. If the stitching head 18 is being moved relative to the preform at a fixed feedrate, the constant velocity mechanism effectively adjusts the velocity of the needle 24 with respect to the preform, decreasing the relative velocity when stitches are being made in thicker regions and increasing the relative velocity when stitches are being made in thinner regions. The constant velocity mechanism could be a walking needle mechanism including springs that push against the needle 24 in the x- and y-directions. Or, the constant velocity mechanism could be an active control for moving the needle according to a predetermined profile. Constant velocity could even be achieved by providing the needle with flexibility.

Thread 34 is drawn from a spool 36 and threaded through an eye of the needle 24. Under control of the control station 16, the motor group 22 positions the needle 24 over a stitching point on the preform, and the needle 24 is plunged into the preform. The bobbin 20, which is on the underside of the preform, grabs the thread 34 and forms a loop. The needle 24 is withdrawn from the preform and, under control of the control station 16, it is repositioned over the next stitching point. Once again, the needle 24 is plunged into the preform, the bobbin 20 grabs the thread 34, forms another loop, and also locks a stitch. The needle 24 is withdrawn from the preform and moved to the next stitching point. The stitching process is repeated.

In addition to reciprocating the needle 24, the stitching head 18 performs a number of automated functions. The stitching head 18 includes a thread gripper 38 for holding the thread at the start of the stitching process and for facilitating thread-cutting; a thread cutter 40 having a ceramic cutting element for automatically cutting the thread 34; and a needle cooler such as a venturi which expands a stream of pressurized air and a hose 42 for directing the expanded, cooled air onto the needle 24. The thread gripper 38, thread cutter 40 and the needle cooler 42 can all be off-the-shelf components that are provided with servomechanisms for automatic control by the control station 16.

The stitching head 18 also includes a thread tensioning mechanism 44 for automatically adjusting the thread tension. The thread tensioning mechanism 44 includes a pair of tension discs 46 mounted on a shaft 50. A spring 52 biases one tension disc 46 against the other to apply tension to the thread 24. Distance between the discs 46 is controlled by a cam 54, which is rotated by a stepper motor 56. The thread tensioning mechanism 44 also includes a pneumatic cylinder 58 that quickly separates the discs 46 to release thread tension.

The thread tensioning mechanism 44 can be operated in a closed loop mode, an open loop or a manual mode. When the thread tensioning mechanism 44 is operated in the closed loop mode, the stepper motor 56 is commanded to move to a position based on a value in a lookup table. The value in the lookup table indicates a thread tension value based on thickness of the preform region being stitched. The thread tension value is compared to a measurement of the thread tension, and an error signal results when the thread tension value does not equal the thread tension measurement. The

stepper motor 56 turns the cam 54, changing the distance between the discs 46, until the error signal is nulled.

The thread tension measurement can be derived from a signal generated by a load cell. Positioned in the thread path near the needle 24, the load cell generates a raw signal that is proportional to thread tension at or near the needle 24.

When the thread tensioning mechanism 44 is operated in the open loop mode, the thread tension value is determined from the lookup table, and a stepper motor command corresponding to the thread tension value is determined from another lookup table. The stepper motor 56, in response to the stepper motor command, rotates the cam 54, which changes the distance between the discs 46. The stepper motor 56 stays at the commanded position regardless of the measured tension in the thread 34.

When the thread tensioning mechanism 44 is operated in the manual mode, thread tension is adjusted by hand-turning a screw (not shown) on the discs 46. The pneumatic cylinder 58 can also be operated manually.

The stitching head 18 also includes a mechanism 60 for automatically adjusting thread path geometry. The thread path geometry mechanism 60 includes an arm 62 having a first end pivoted to the stitching head's housing and a second end extending into the thread path. A stepper motor 64 or servo moves the arm 62 to increase or decrease the thread path. The thread path is increased when additional thread is needed for stitching through thicker regions, and the thread path is decreased when less thread is needed for stitching through thinner regions. Although the mechanism 60 is shown as having a pivoting arm 62, another mechanism could have a sliding arm that moves linearly into the path of the thread 34. As with the thread tensioning mechanism 44, the thread path geometry mechanism 60 is table-driven. The stepper motor 64 is commanded move to a position based on a stepper motor count in a lookup table. The stepper motor count in the lookup table corresponds to thread path geometry based on thickness of the preform region being stitched.

FIG. 5 shows the control station 16 in greater detail. The control station 16 includes a processor 66 and computer memory 68. Encoded in the computer memory 68 is a host program 70 and a file 72 including instructions for making the stitches, instructions for controlling stitching speed, and instructions for retracting and extending the stitching head 18 to and from the preform. The file 72 also includes instructions for commanding the unique functions of the stitching head 18 such as cooling the needle 24, gripping the thread 34, and cutting the thread 34. The instructions can be based on an EIARS-274 format, which is a standard for the machine tool industry.

The file 72 further includes instructions indicating a value for thickness of the preform. The instructions indicating the preform thickness values are processed by the control station 16 as described below to generate commands for adjusting the thread path geometry and the thread tension.

The processor 66 executes the host program 70, which instructs the processor 66 to fetch the instructions from the file 72. When an instruction is fetched, the processor 66 generates a command that is sent to an I/O card 74 or a motion controller card 76. When the I/O card 74 receives a command it generates a control signal having an appropriate voltage level for an actuator such as solenoid. When the motion controller card 76 receives a command, it generates a control signal having an appropriate voltage level for an actuator such as a stepper motor. For example, the processor 66 fetches an instruction for making a stitch, and sends position commands to the motion controller card 76. The

motion controller card 76 sends control signals to the stepper or servo motors of the motor group 22. Or, the processor 66 fetches an instruction for turning on needle cooling, and sends a command to the I/O card 74, which generates a control signal that open an air supply valve.

The control station 16 further includes an operator console 80 including a display and keyboard for controlling the stitching machine 14, viewing stitching data, and viewing status and health of the stitching machine 14. A peripheral device 82 such as a floppy disk drive, CD ROM drive or tape drive allows the host program 70 and the file 72 to be loaded into the computer memory 68. In the alternative, the host program 70, the file 72 could be downloaded from a network. The file 72 could even be entered from the operator console 80.

The processor 66 processes an instruction indicating the preform thickness value by accessing a first lookup table 84 to determine proper tension for the corresponding preform thickness value. Then the processor 66 accesses a second lookup table 86 to determine the corresponding stepper motor count for the proper tension. If the processor 66 finds an exact match for thread tension in the second lookup table 86, it uses the corresponding stepper motor count. If no match is found, the processor 66 uses the closest values for thread tension and interpolates a count for the stepper motor 58 of the thread tensioning mechanism 44.

The processor 66 also accesses the first lookup table 84 to determine a count for the stepper motor 64 of the thread path geometry mechanism 60.

The first and second lookup tables 84 and 86 are stored in the computer memory 68. Exemplary entries for the first and second lookup tables 84 and 86 are shown in Tables 1 and 2. Preform thickness values are indicated by a stack count.

TABLE 1

Stack Count	Thread Tension	Thread Path Geometry Motor Count
1	75 g	230
2	85 g	300

TABLE 2

Thread Tension	Thread Tension Motor Count
75 g	300
90 g	375

FIG. 6 shows a method of operating the stitching head 18. The host program 70 is executed and begins to instruct the processor 66 to access the file 72 and fetch instructions (step 100). When an instruction indicating a preform thickness value is fetched (step 102), the processor 66 automatically adjusts the thread tension and thread path geometry in the stitching head 18. The processor 66 accesses the first lookup table 84 to determine the corresponding count for the stepper motor 64 of the thread path geometry mechanism 60 (step 104). The motion control card 76 generates a stepper motor command (step 106), which causes the stepper motor 64 of the thread path geometry mechanism 60 to move to the stepper motor count.

The processor 66 also looks up a thread tension value in the first lookup table 84 (step 108). If the open loop mode

is commanded (step 110), the processor 66 accesses the second lookup table 86 to determine the corresponding stepper motor count for the stepper motor 56 of the thread tensioning mechanism 44 (step 112). The motion control card 76 generates a stepper motor command (step 114), which causes the stepper motor 56 of the thread tensioning mechanism 44 to move to the stepper motor count.

If the closed loop mode is commanded (step 110), the processor 48 does not access the second lookup table 86 but instead generates an error signal indicating a difference between the thread tension measurement and the thread tension value from the first lookup table 84 (step 116). The error signal is used to drive the stepper motor 56 of the thread tensioning mechanism 44 until the thread tension measurement and the thread tension value are about the same.

When an instruction for making a stitch at a stitching point is fetched (step 118), the motion controller card 76 generates position commands for moving the stitching head 18 to the x- and y-coordinates indicated in the stitching instruction (step 120). The position commands cause the motor group 22 to position the stitching head 18 over the stitching point. Once the stitching head 18 is positioned over the stitching point, the processor 66 generates a command that causes the needle drive mechanism 28 to reciprocate the needle 24 (step 122).

When an instruction for performing a unique function of the stitching machine is fetched (step 124), the processor 66 commands the stitching head 18 to perform the unique function (step 126). For example, the processor 66 fetches a command for cooling the needle 24. The I/O card 74, in response to the needle cooling instruction, sends a control signal commanding a valve to supply air to a venturi. Cooled air flows from the venturi, through the hose 42, to the needle 24.

The file 72 can also include instructions for performing "canned cycles." In the alternative, a canned cycle might be commanded from the operator console 80. If a canned cycle is instructed from the file 72 or commanded from the operator console 80 (step 128), the processor 66 performs the canned cycle (step 130).

There might be a canned cycle for starting a stitch. The stitching head 18 is commanded to use a low thread tension for making a few stitches initial stitches. Once the low-tension stitches have been made and bobbin thread is locked, the stitching head 18 is commanded to increase tension and pull the needle 24 up through the preform. Then, the stitching head 18 is commanded to back off to the proper thread tension for the subsequent stitches.

There might also be a canned cycle for gripping and cutting thread 34. Thread tension is released and the needle bar 26 is retracted to create a thread tail. Then thread tension is turned back on and the thread gripper 38 is opened and extended. The thread gripper 38 grips the thread 34, and the thread cutter 40 heats up and cuts the thread 34. Tension is turned off, and the needle bar 26 is lowered.

The processor 66 fetches additional instructions until the last instruction in the file 72 is accessed (steps 132 and 134).

FIG. 7 shows the software architecture 200 for generating native code for stitching the preform. A geometric model of the preform (e.g., a loft surface of a wing cover) is generated by CAD software 202. The geometric model, which defines the surface geometry of the preform, is stored in a neutral file format such as "IGES," "STEP PDS" or "DXF." Such CAD software 202 is commercially available. In the alternative, the geometric model could be a mathematical model such as

a series of polynomials describing the surface of the preform. However, the neutral file format allows the file of the geometric model to be processed by commercially available CAM software 204.

Tool paths for the model are generated by the CAM software 204. Each tool path includes instructions for making the stitching points. The instructions are generated according to a standard format such as ANSI X3.37 for Cutting Line Source data. At least one instruction is generated for each stitching point.

Additional instructions are manually inserted into the tool paths, between the instructions for making the stitches. Programmers use an editor 206 to manually edit the tool paths and insert instructions for retracting and extending the stitching head 18 and instructions for turning the stitching on and off. The programmers add these additional instructions by working off the geometric model of the preform, identifying constraints on the tool paths, and inserting the appropriate instructions such that the constraints are not violated. For example, a programmer would trace the stitching instructions on a tool path to a stringer, insert an instruction for retracting the stitching head 18 so as not to hit the stringer, and insert an instruction for extending the stitching head 18 on a trailing side of the stringer after the stitching head 18 clears the stringer. Working off the geometric model of the preform, the programmers also manually insert instructions for cutting and gripping the thread 34. Instead of cutting, the thread 34, the programmer might decide to drag the thread 34.

After the additional instructions have been added to the tool paths, the tool paths are supplied to a post-processor 208. The post-processor 208 converts the instructions in the ANSI X3.37 format to native code that is readable by the stitching machine 14. Accessing a user-defined library 210, the post-processor 208 converts user-defined instructions (e.g., needle cooling) into native code. The native code could adhere to an EIA RS-274 standard.

The post-processor 208 also generates the instructions indicating part thickness values and inserts the instructions into the tool paths. Going down the tool paths and examining the instructions for making stitches, the post-processor 208 accesses a zone table 212 to determine the preform thickness value corresponding to each stitching point and whether the preform thickness value changes between consecutive stitching points. If the preform thickness value changes, the post processor 208 inserts an instruction indicating the new preform thickness value between the two instructions for making stitches at the consecutive stitching points.

Knowing the preform thickness value at each stitching point, the post-processor 208 also uses the zone table 212 to generate instructions for setting stitching speed and turning needle cooling on and off.

An exemplary zone table is shown in Table 3, and an exemplary preform P is shown in FIG. 8. The preform P is divided into a plurality of zones z1 to zn. Each zone zn has a corresponding preform thickness value such as a stack count. Moreover, each zone z1 to zn is defined by three or four points, allowing for the preform thickness value to be determined quickly.

TABLE 3

Zone	Stack Count	Speed	Needle Cooling
z1	2	XX	off
z2	5	XX	off

Thus, using the zone table **212**, the post-processor **208** can quickly determine the preform thickness value, stitching speed and needle cooling condition of a stitching point lying in one of the zones **z1** to **zn**.

After the native code has been generated, it is tested in a simulation module **214**. Simulation ensures that the stitching machine **14** functions properly, the stitching heads **18** do not crash into the material support table **12**, the stitching heads **18** do not crash into stringers and violate other constraints, etc.

After the native code has been successfully simulated and debugged, a file **72** containing the native code is loaded into the control station **16**. While the file **72** is being executed, the processor **66** accesses the first and second lookup tables **84** and **86** to determine thread tension and stepper motor counts for thread path geometry. The processor **66** also accesses any canned cycle **216** that might be called.

FIG. 9 shows a computer system **300** for generating the native code. The computer system **300** includes a processor **302**, a display **304**, I/O devices **306** and memory **308**. The memory **308** stores the commercially available CAD/CAM software **310**, an editor **312** for inserting the additional instructions into the tool paths, post processing software **314**, and a simulator program **316**. The memory **308** also includes the user-defined library **210** and the zone table **212**. The computer system **300** could be a personal computer, a workstation or a mainframe.

Thus disclosed is an invention that makes stitches in variable-thickness, fiber composite preforms with little to no operator intervention. The invention automatically adjusts thread tension, thread path geometry and stitching speed for variations in the thickness of the preform. No longer must an operator stop the stitching and adjust thread tension or thread path geometry. The stitching head can make stitches in a fiber composite material having a variable thickness between 0 to 1.5 inches. Such variable thickness preforms can be stitched quickly, cost-effectively and precisely.

Changes and modifications may be made without departing from the spirit and scope of the invention. For example, thickness could be indicated by a parameter other than stack count. The stack count merely provides a convenient reference scheme.

In general, although a preferred embodiment of the present invention has been described in detail hereinabove, it should be clearly understood that many other variations and/or modifications of the basic inventive concepts herein taught which may appear to those skilled in the pertinent art will still fall within the spirit and scope of the present invention, as defined in the appended claims.

What is claimed is:

1. A method of using a computer to generate native code for a stitching machine, the method comprising the steps of:
 using the computer to generate a geometry model, where said geometry model defines the surface geometry of a part to be stitched;
 using the computer to generate tool paths from the geometry model, the tool paths including a first plurality of instructions for making stitches at a plurality of stitching points on the part;

using the computer to generate a second plurality of instructions indicating respective thickness values of the part at the plurality of respective stitching points; and

inserting the instructions of the second plurality of instructions between the instructions of the first plurality of instructions.

2. The method of claim 1, wherein the computer uses a program to generate the geometry model selected from the group consisting of a CAD program and a CAM program.

3. The method of claim 1, further comprising the step of stitching a workpiece comprised of a stack of fabric plies.

4. The method of claim 3, wherein the tool paths are generated according to an X3.37 CLS format.

5. The method of claim 1, wherein the computer generates the second plurality of instructions by performing the steps of:

generating a table of thickness values; and

looking up the thickness values at each of the stitching points.

6. The method of claim 1, further comprising the step of manually inserting additional instructions into the tool paths.

7. The method of claim 1, wherein the computer accesses a stitching vocabulary library to convert user-defined instructions to the native code.

8. The method of claim 7, wherein the user-defined instructions include instructions for performing unique functions of stitching machine.

9. The method of claim 1, further comprising the step of using the computer to simulate the native code.

10. The method of claim 1, further comprising the step of using the computer to run canned cycles.

11. The method of claim 1, further comprising the step of using a processor to run the native code.

12. The method of claim 11, further comprising the step of accessing a table for thread tension values corresponding to the thickness values.

13. The method of claim 12, further comprising the step of accessing a table for stepper motor count corresponding to the thread tension values.

14. The method of claim 12, further comprising the steps of:

measuring thread tension;

generating an error signal based on the difference between the measured thread tension and the thread tension value; and

automatically adjusting the thread tension using the generated error signal until the thread tension measurement is approximately the same as the thread tension value.

15. The method of claim 12, further comprising the step of accessing a table for thread path geometry values corresponding to the thickness values.

16. The method of claim 12, further comprising the step of accessing a table for needle cooling conditions corresponding to the thickness values.

17. The method of claim 12, further comprising the step of accessing a table for stitching speed corresponding to the thickness values.

18. A computer system for generating native code for a CNC stitching machine, the system comprising:

means for generating a geometry model defining the surface geometry of a part to be stitched;

means for generating tool paths from the geometry model, the tool paths including a first plurality of instructions for making stitches at a plurality of stitching points on the part;

a zone table for determining respective thickness values of the part at the plurality of respective stitching points; and

11

means for accessing the zone table to generate a second plurality of instructions indicating said respective thickness values, and inserting the instructions of the second plurality of instructions between the instructions of the first plurality of instructions.

19. The computer system of claim 18, further comprising a user-defined library for generating a third set of instructions.

20. The computer system of claim 18, further comprising means for simulating the native code.

21. A method of stitching a part using computer control, the method comprising the steps of:

using a computer to generate a geometry model, where said geometry model defines the surface geometry of a part to be stitched;

using the computer to generate tool paths from the geometry model, the tool paths including a first plurality of instructions for making stitches at a plurality of stitching points on the part;

using the computer to generate a second plurality of instructions indicating respective thickness values of the part at the plurality of respective stitching points;

12

inserting the instructions of the second plurality between the instructions of the first plurality of instructions;

providing a stitching machine comprising a stitching head including a servo for setting thread tension;

using a processor to access at least one of said second plurality of instructions indicating thickness values;

using the processor to determine a thread tension value corresponding to the accessed thickness value;

commanding the servo to the determined thread tension value; and

stitching the part.

22. The method of claim 21, further comprising the step of commanding the servo in a closed loop mode of operation.

23. The method of claim 21, further comprising the step of commanding the servo in an open loop mode of operation.

24. The method of claim 21, further comprising the step of using the processor to determine a thread path geometry value corresponding to the accessed thickness value.

* * * * *