



US006297907B1

(12) **United States Patent**
Wang

(10) **Patent No.:** **US 6,297,907 B1**
(45) **Date of Patent:** **Oct. 2, 2001**

(54) **DEVICES BASED ON SURFACE PLASMON INTERFERENCE FILTERS**

(58) **Field of Search** 345/88; 348/744; 349/105, 106, 196; 359/585, 578, 579

(75) **Inventor:** **Yu Wang**, La Crescenta, CA (US)

(56) **References Cited**

(73) **Assignee:** **California Institute of Technology**, Pasadena, CA (US)

U.S. PATENT DOCUMENTS

(*) **Notice:** Subject to any disclaimer, the term of this patent is extended or adjusted under 35 U.S.C. 154(b) by 0 days.

5,570,139 * 10/1996 Wang 348/744

* cited by examiner

Primary Examiner—Audrey Chang

Assistant Examiner—Craig Curtis

(21) **Appl. No.:** **09/144,519**

(74) *Attorney, Agent, or Firm*—Fish & Richardson P.C.

(22) **Filed:** **Aug. 31, 1998**

(57) **ABSTRACT**

Related U.S. Application Data

Devices based on surface plasmon filters having at least one metal-dielectric interface to support surface plasmon waves. A multi-layer-coupled surface plasmon notch filter is provided to have more than two symmetric metal-dielectric interfaces coupled with one another to produce a transmission spectral window with desired spectral profile and bandwidth. Such notch filters can form various color filtering devices for color flat panel displays.

(63) Continuation-in-part of application No. 08/949,151, filed on Oct. 10, 1997, now Pat. No. 5,986,808.

(60) Provisional application No. 60/056,050, filed on Sep. 2, 1997, provisional application No. 60/059,247, filed on Sep. 18, 1997, and provisional application No. 60/060,733, filed on Oct. 1, 1997.

(51) **Int. Cl.⁷** **G02B 1/10**

(52) **U.S. Cl.** **359/585**; 349/106; 349/196; 359/578; 359/579

10 Claims, 17 Drawing Sheets

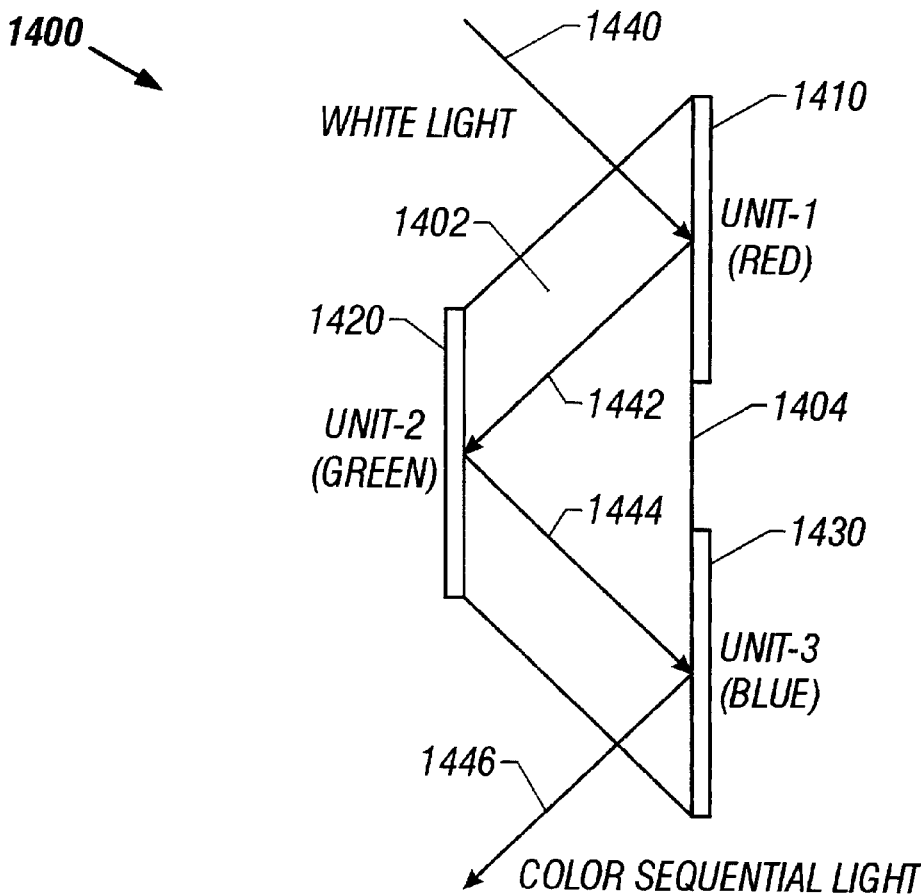

100 →

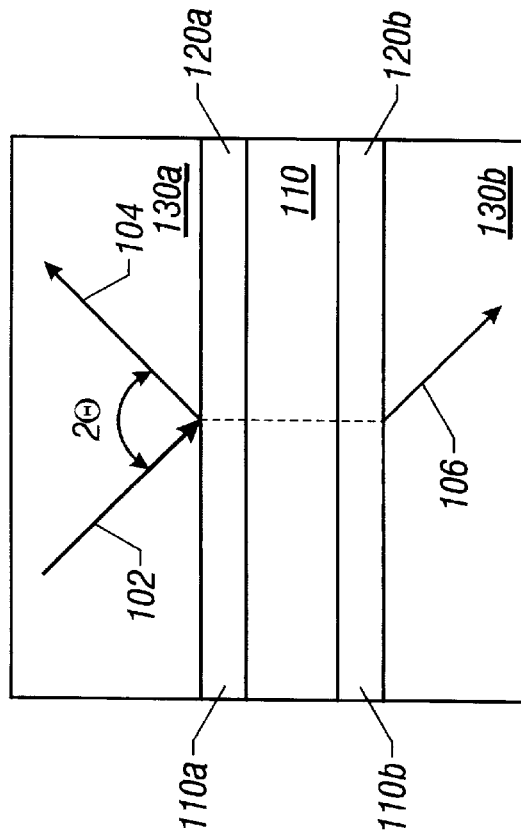

FIG. 1A

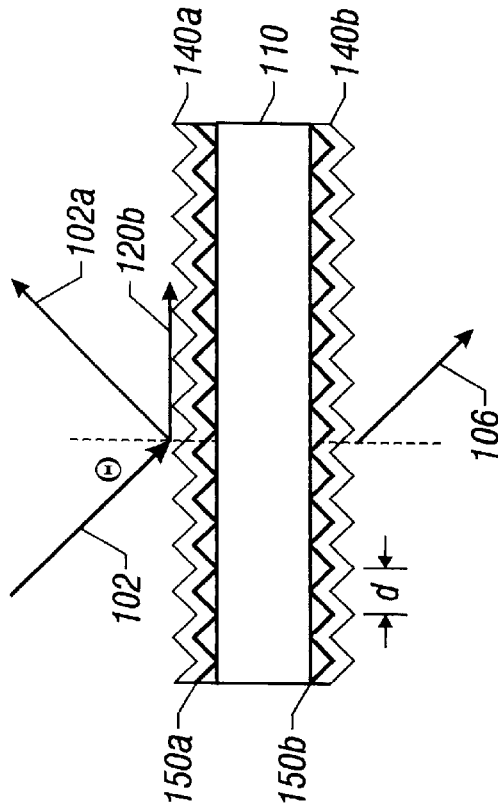

FIG. 1B

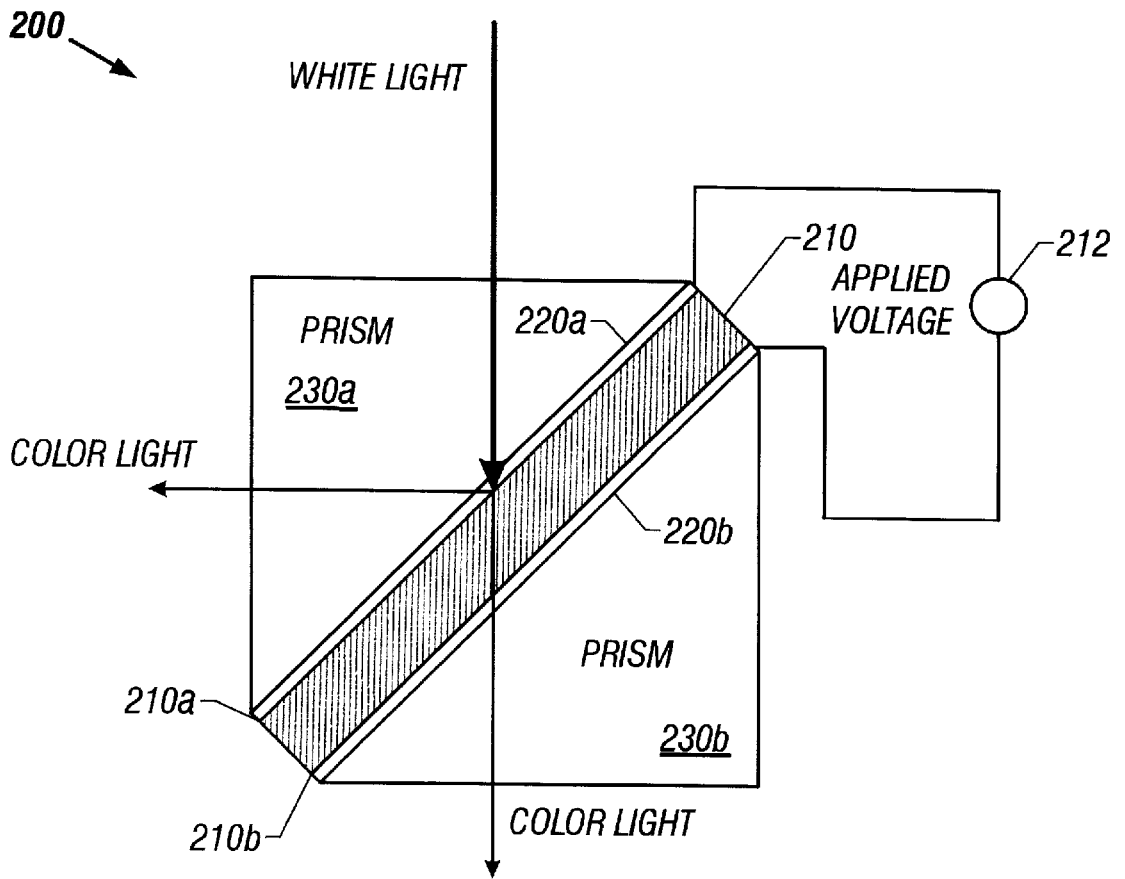

FIG. 2

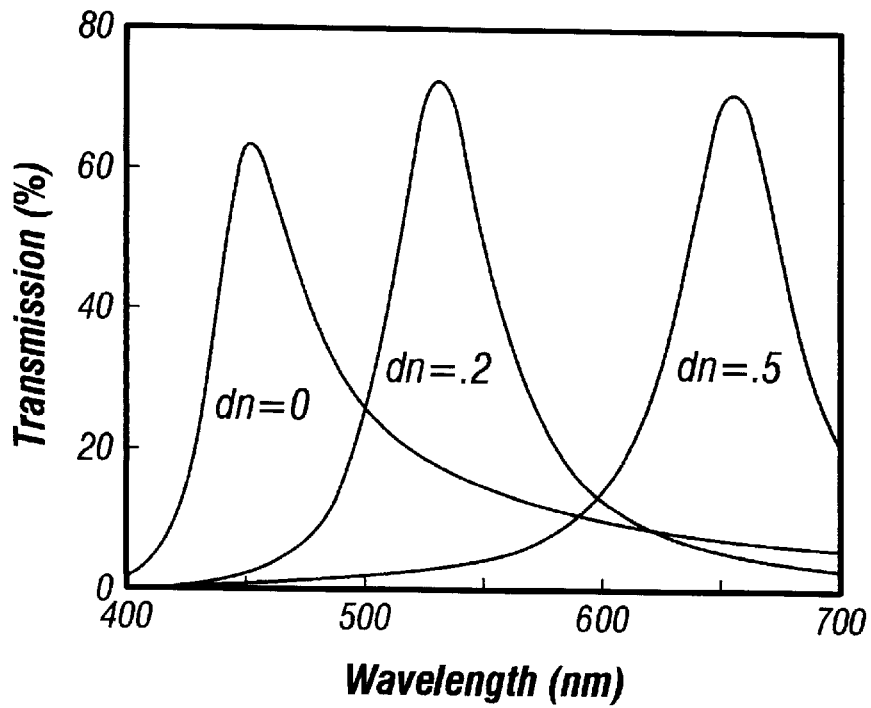

FIG. 3A

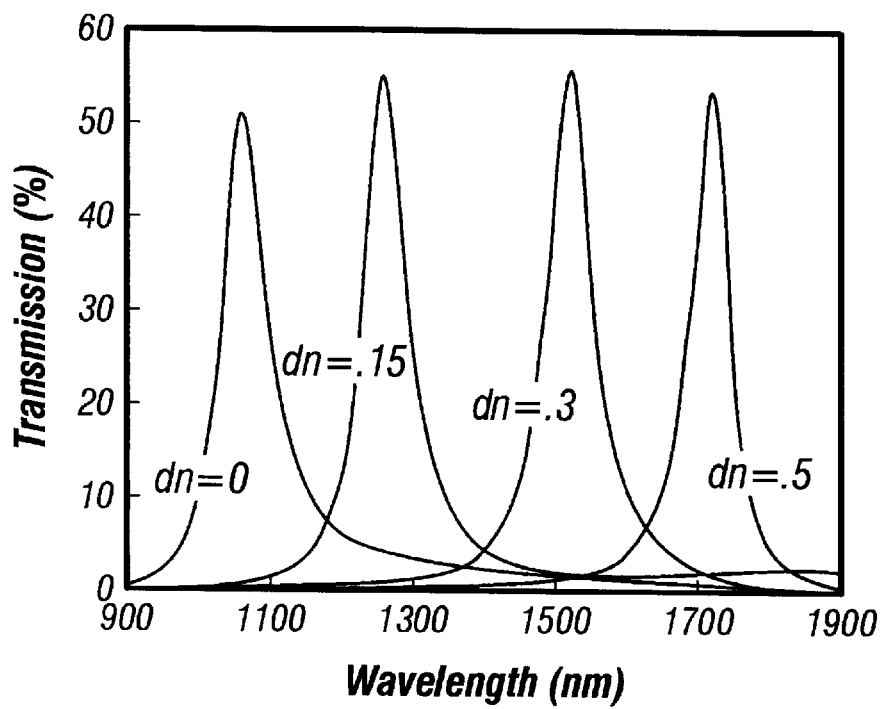

FIG. 3B

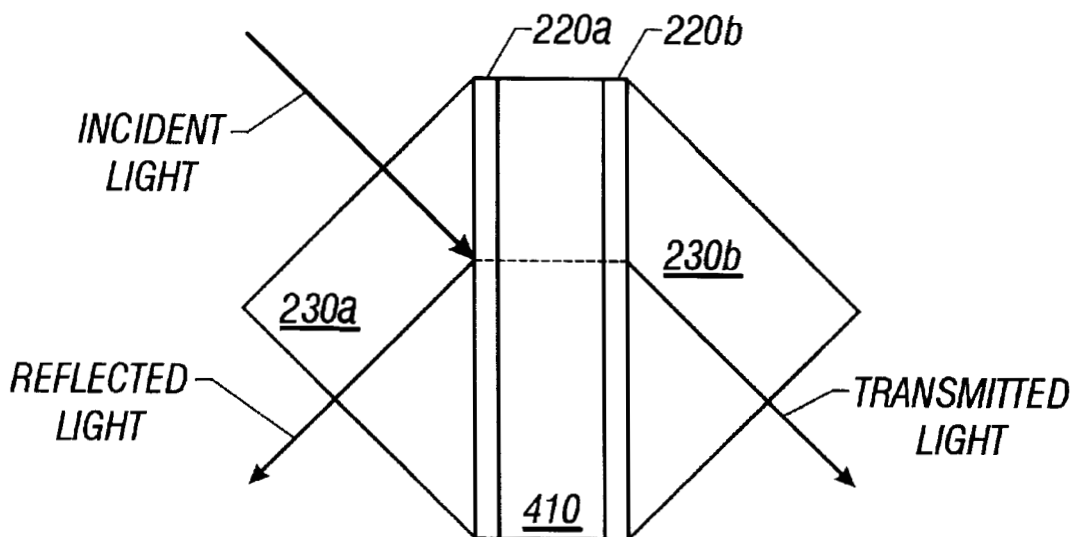

FIG. 4

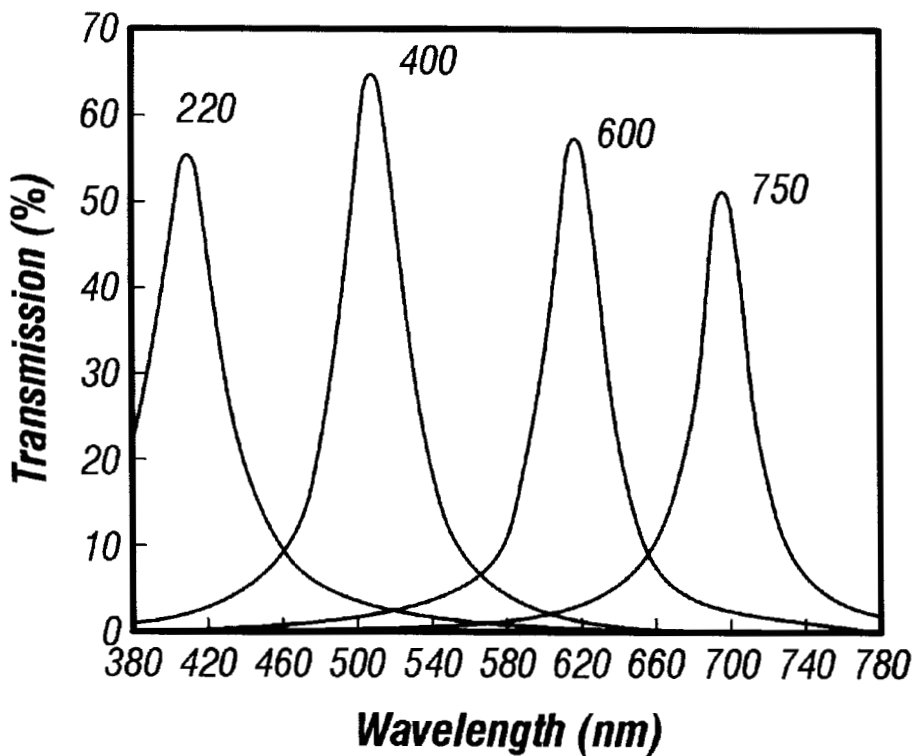

FIG. 5

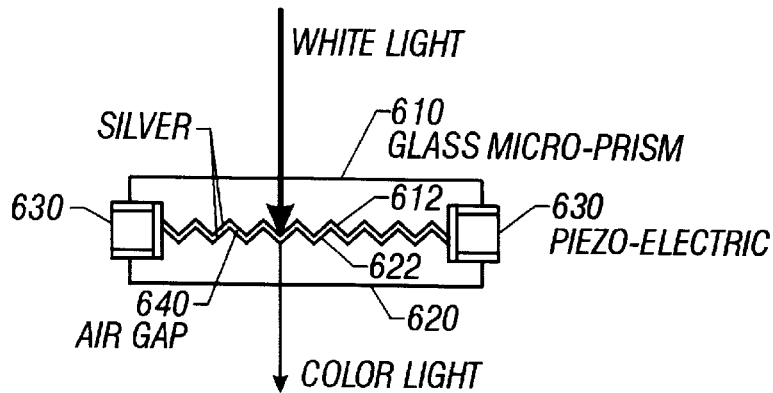

FIG. 6

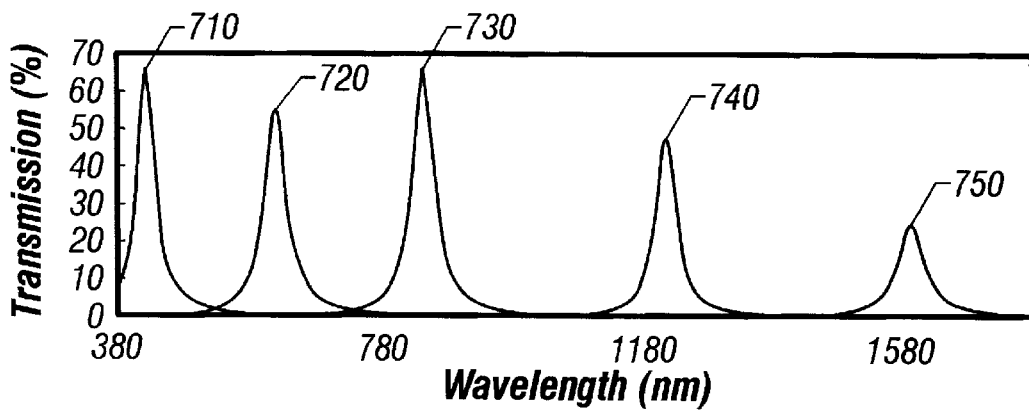

FIG. 7

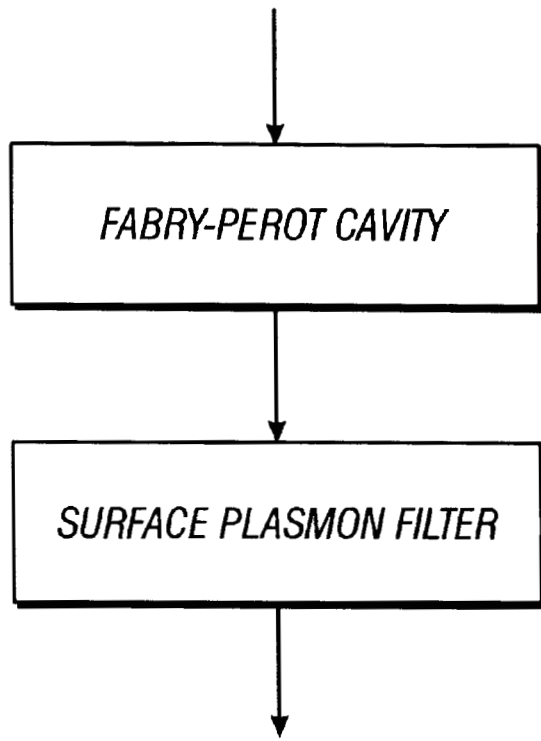

FIG. 8A

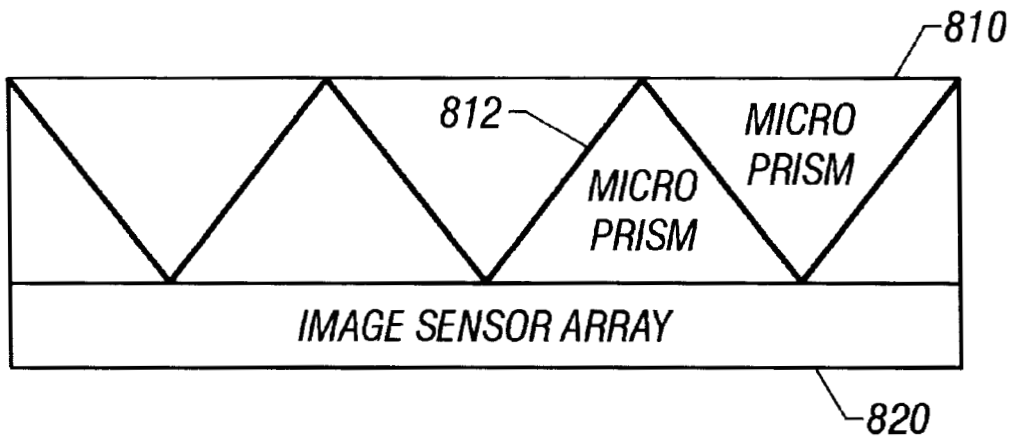

FIG. 8B

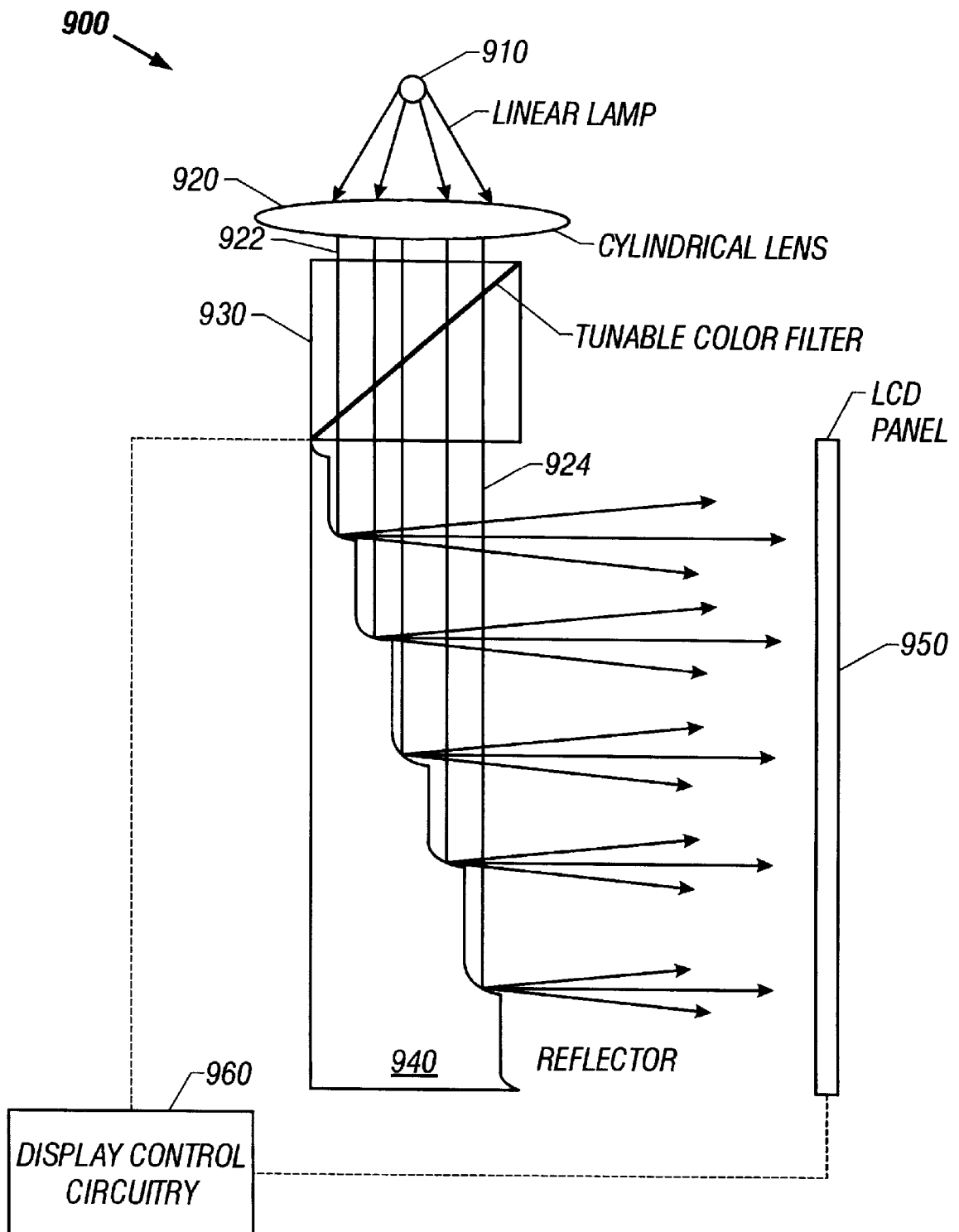

FIG. 9

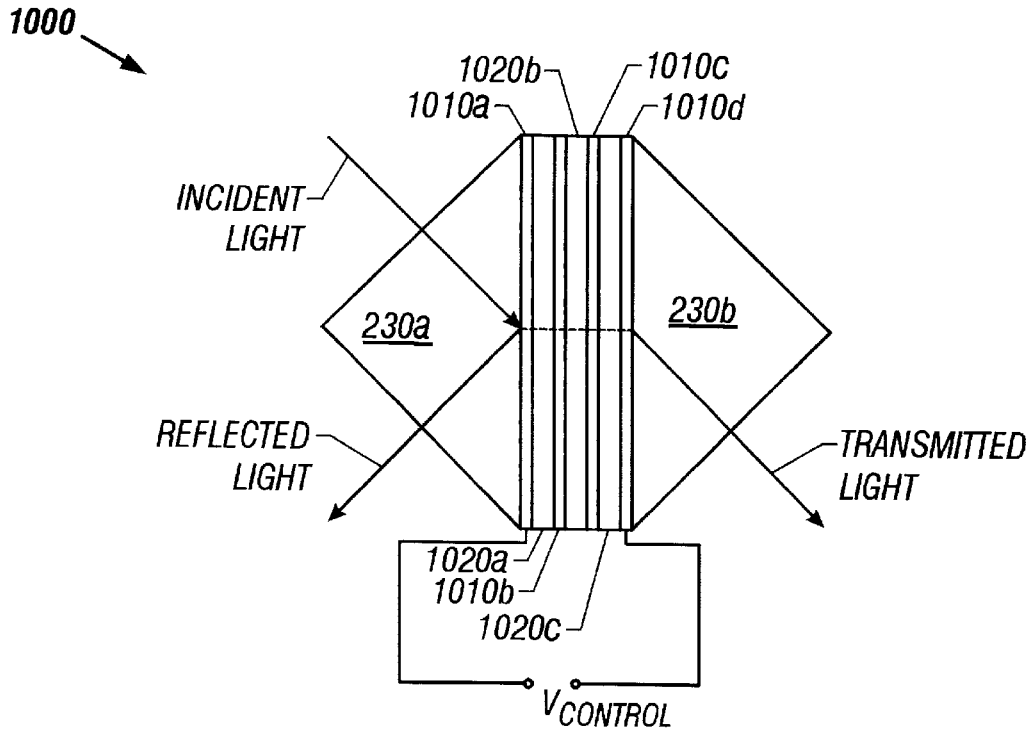

FIG. 10

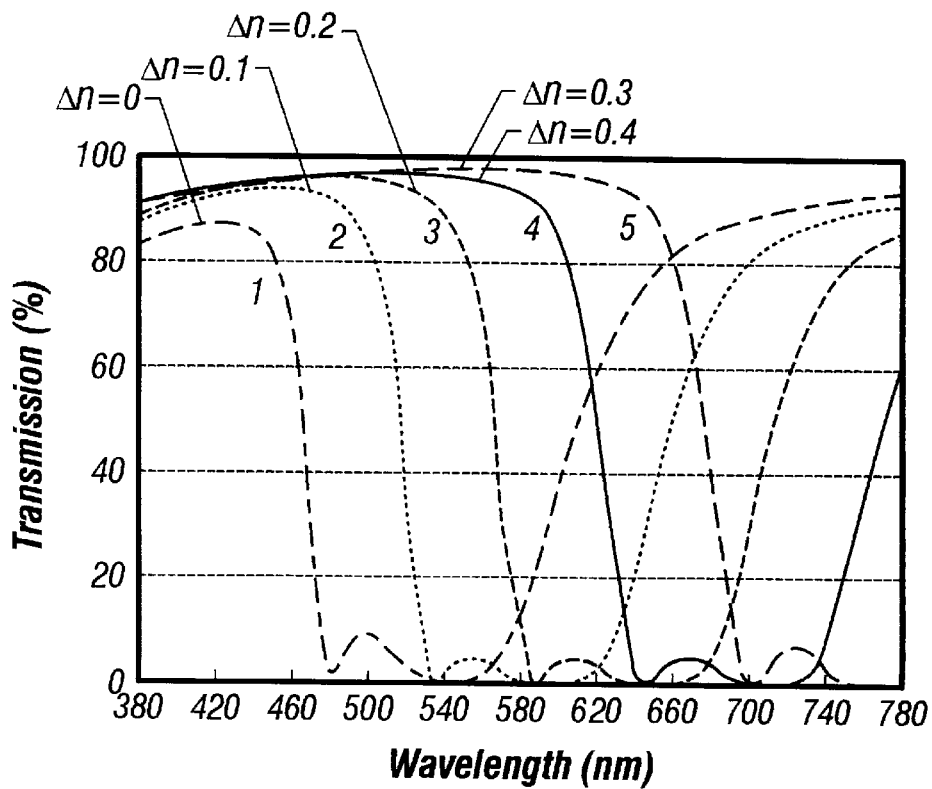

FIG. 11

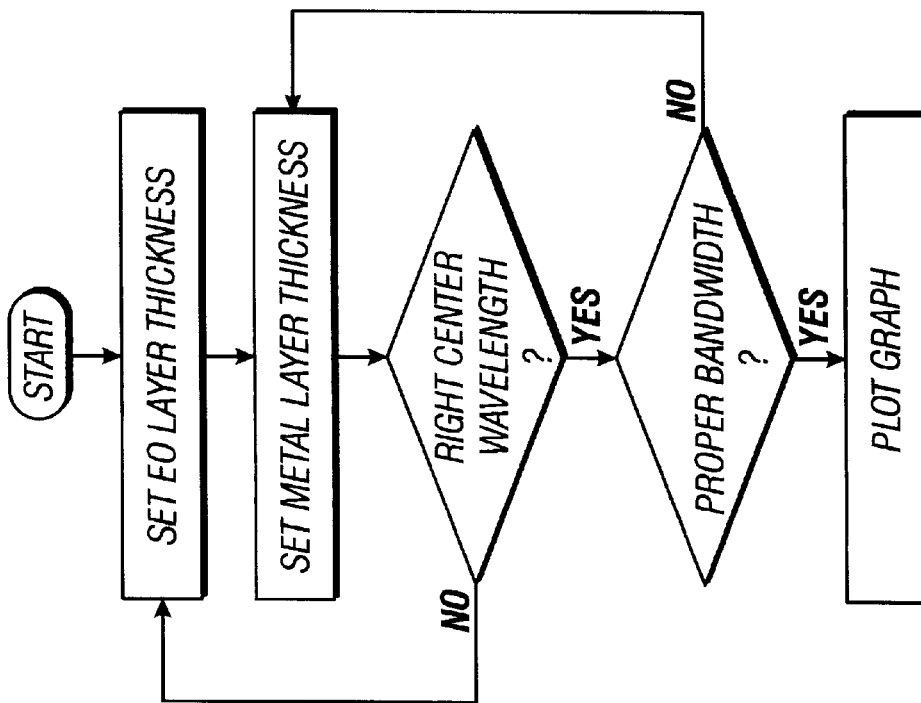

FIG. 12

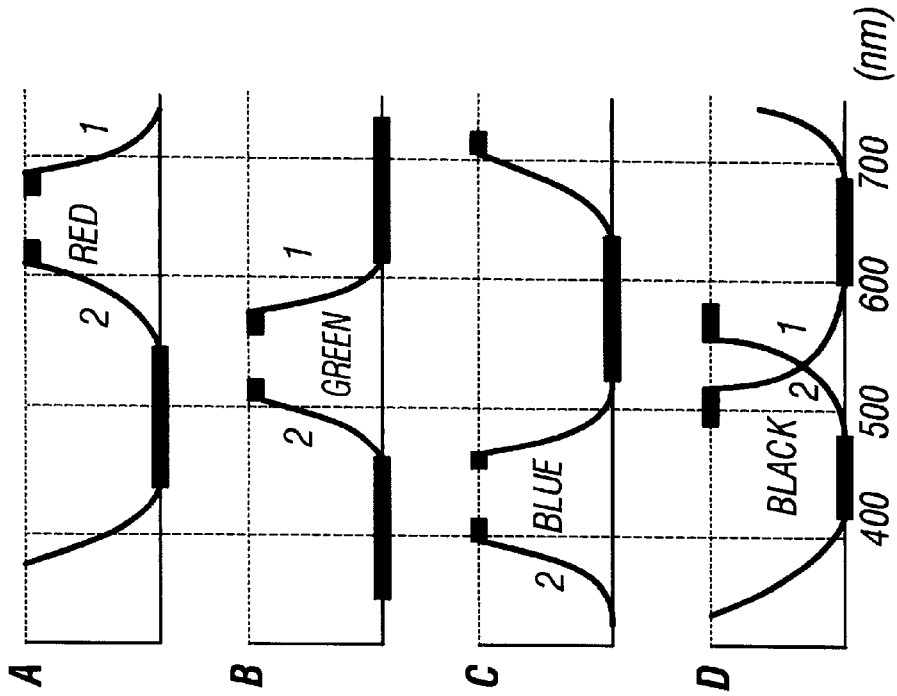

FIG. 13A

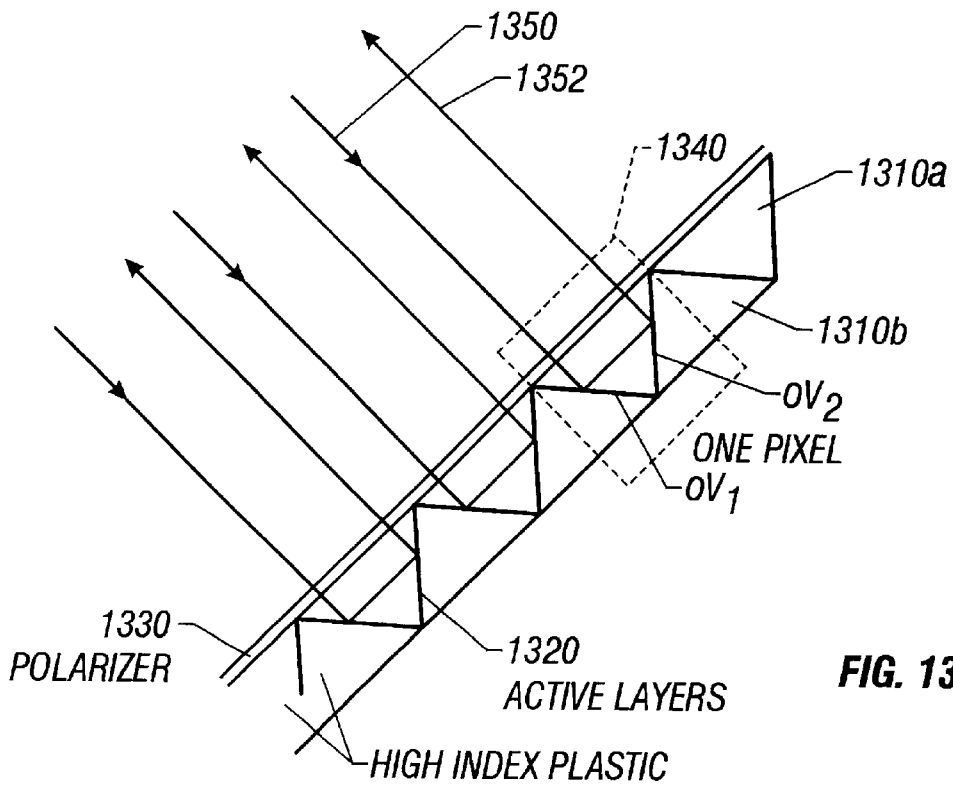

FIG. 13B

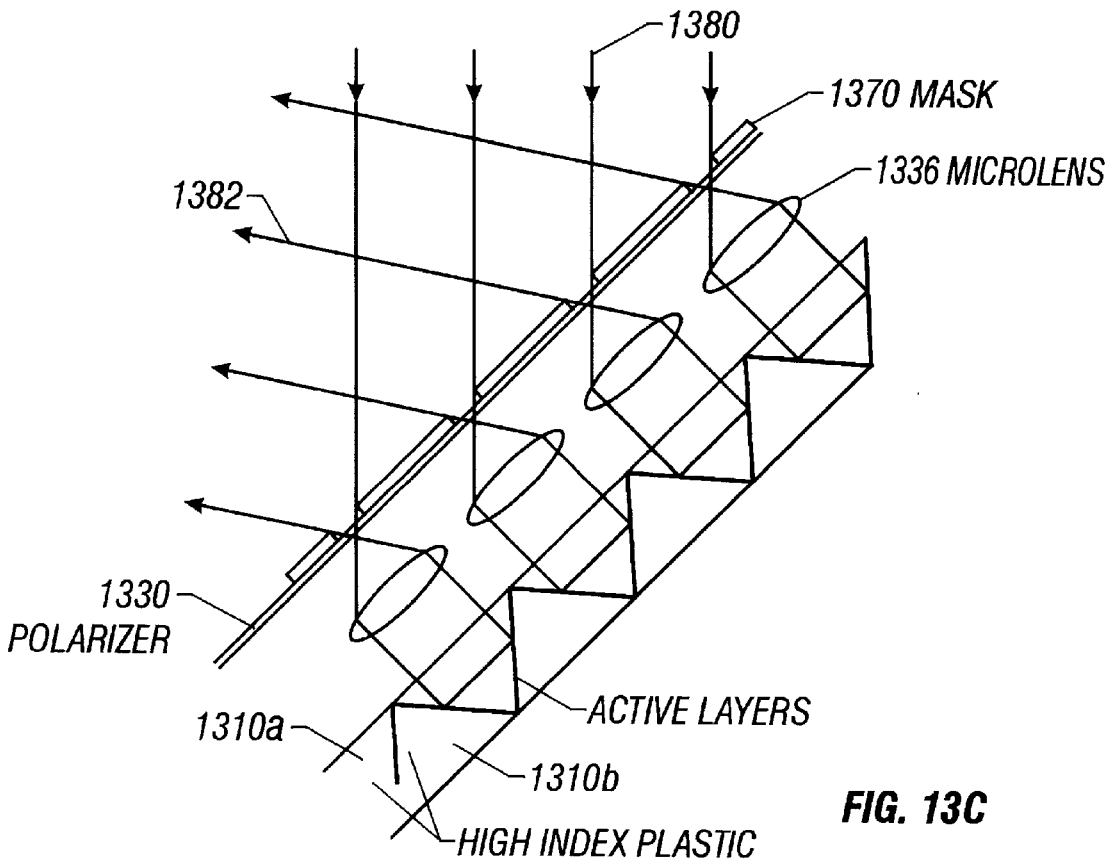

FIG. 13C

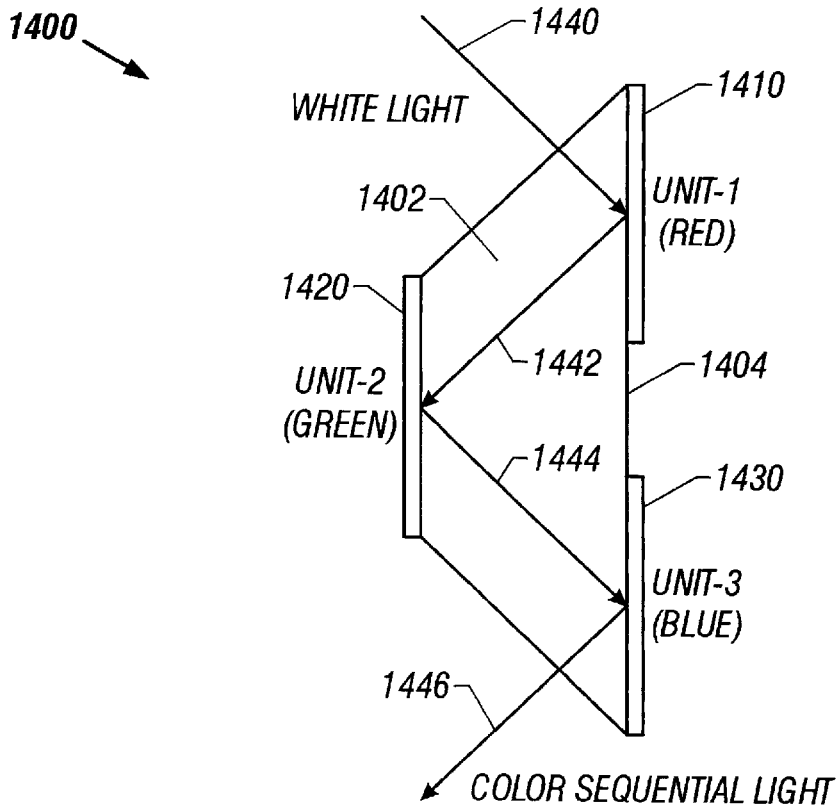

FIG. 14A

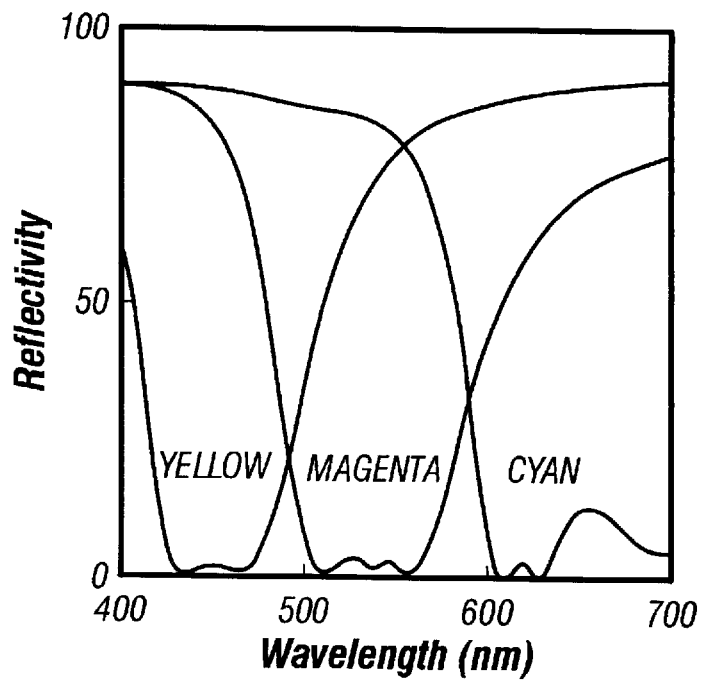

FIG. 14B

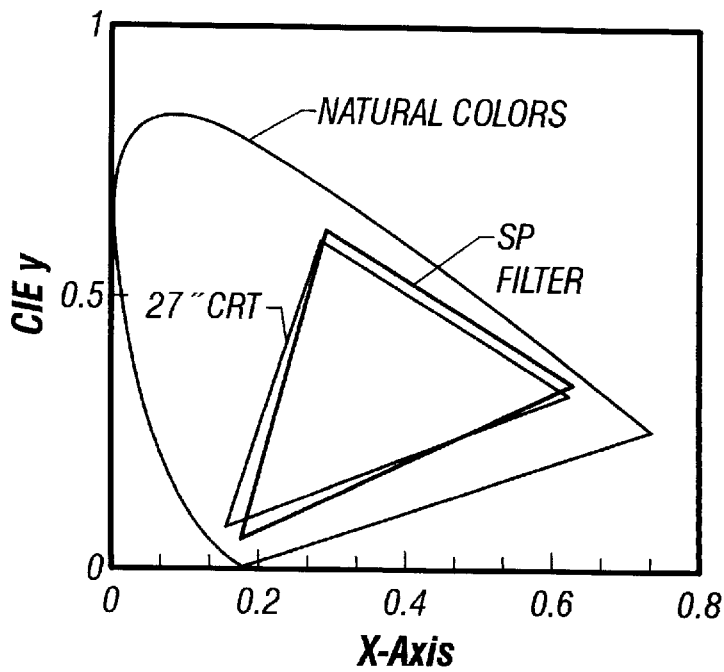

FIG. 14C

1500 →

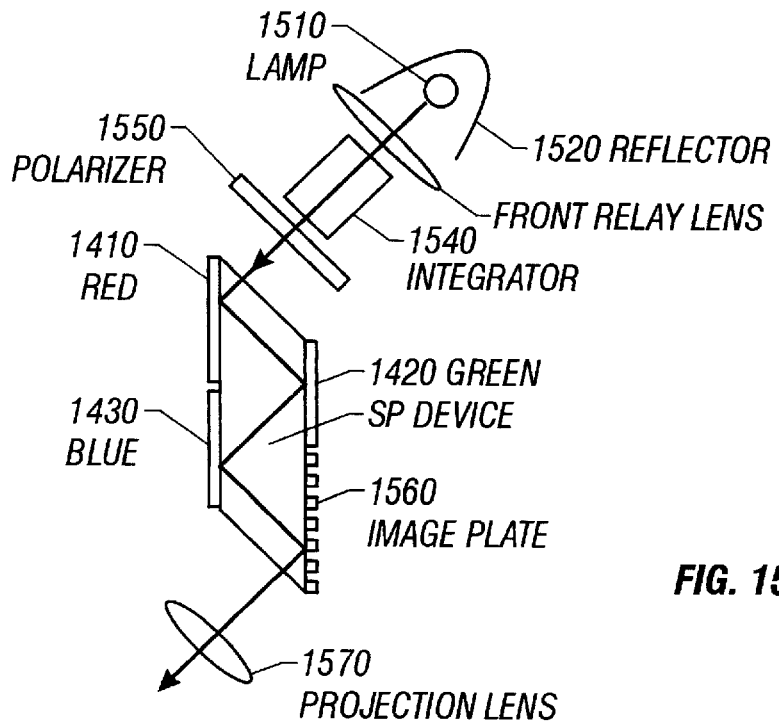

FIG. 15

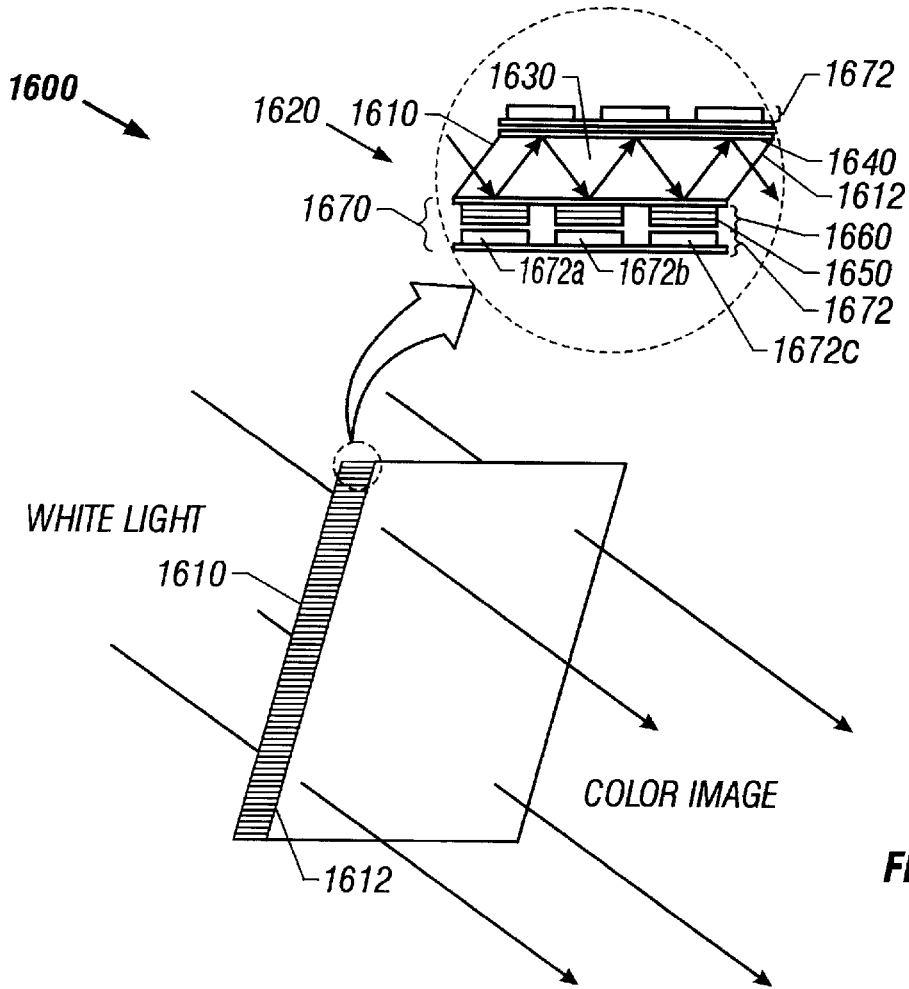

FIG. 16A

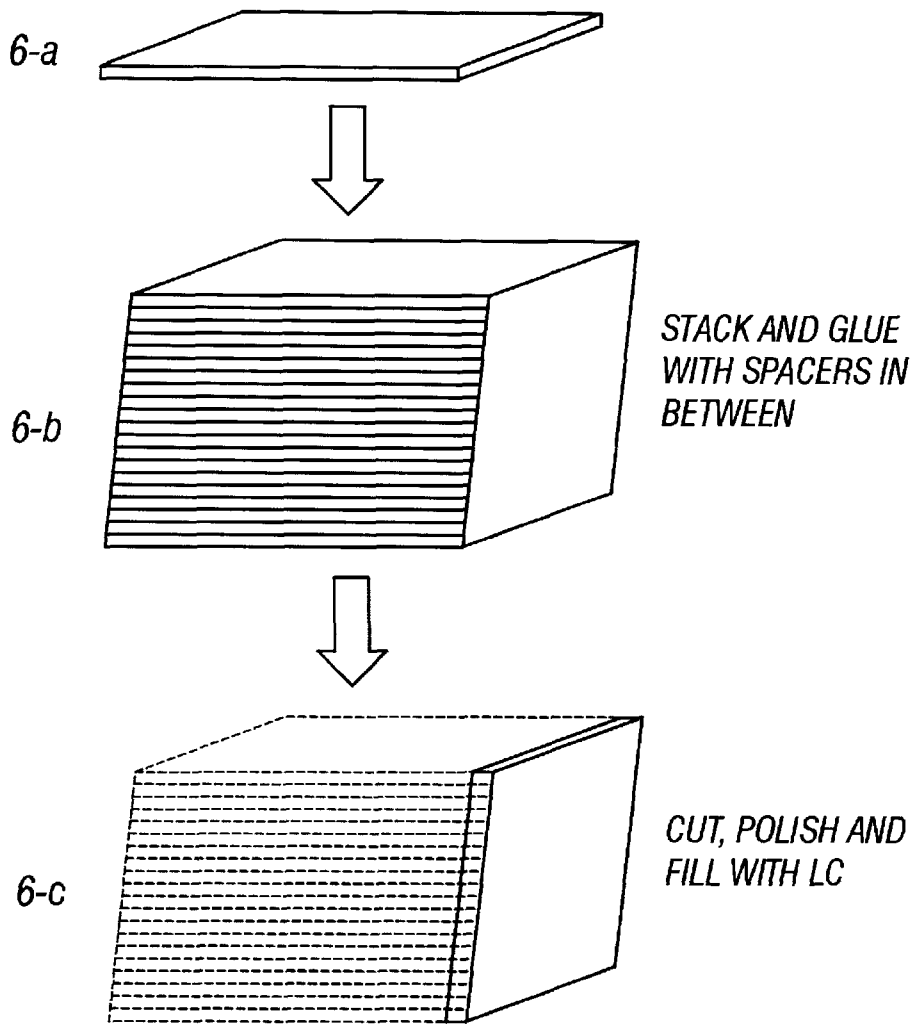

FIG. 16B

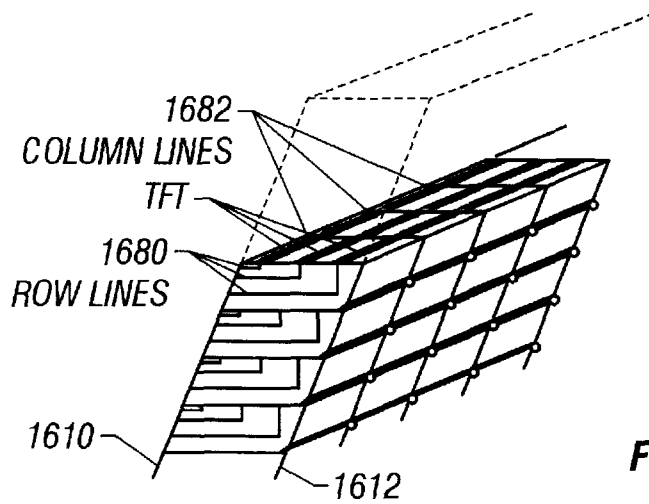

FIG. 16C

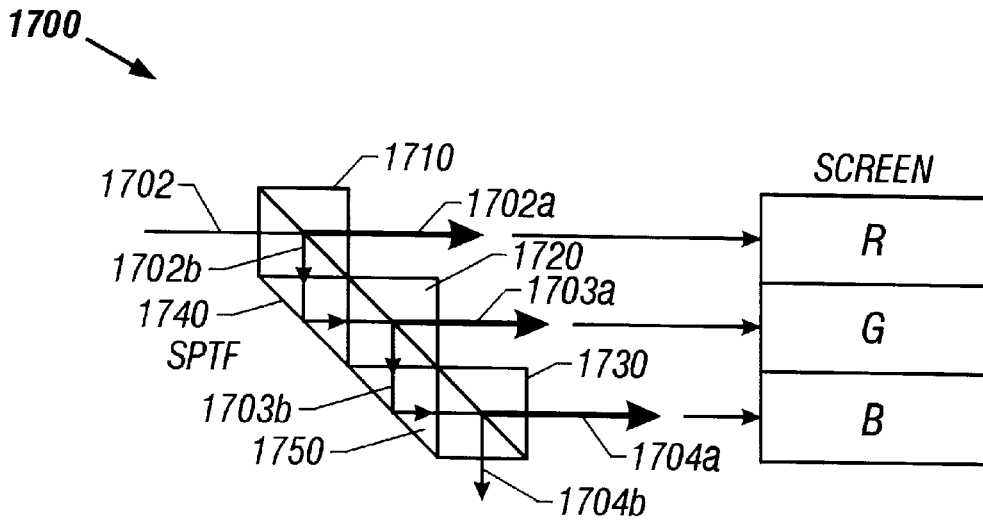

FIG. 17A

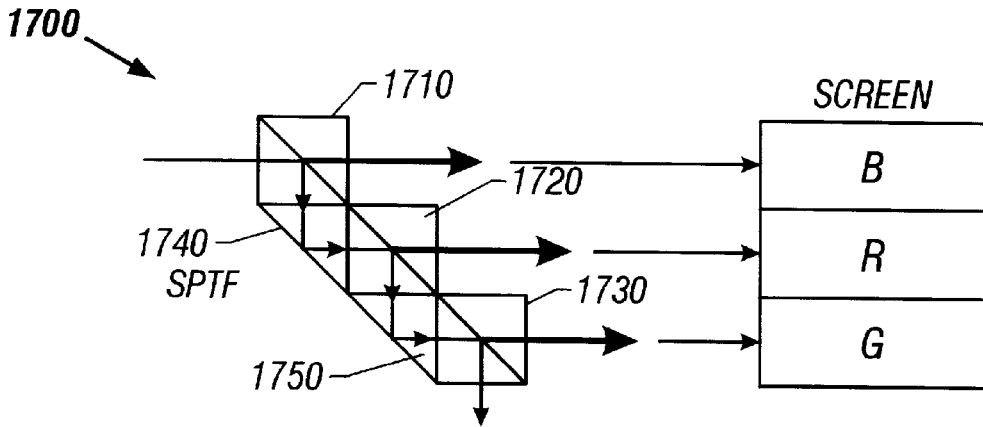

FIG. 17B

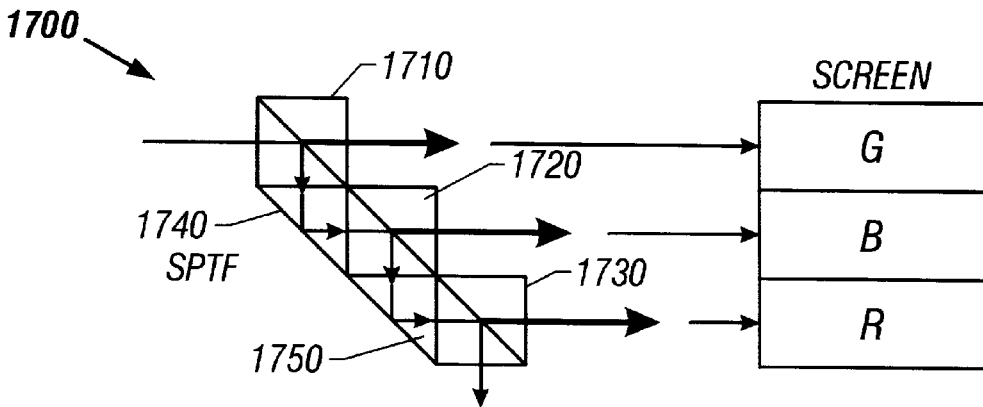

FIG. 17C

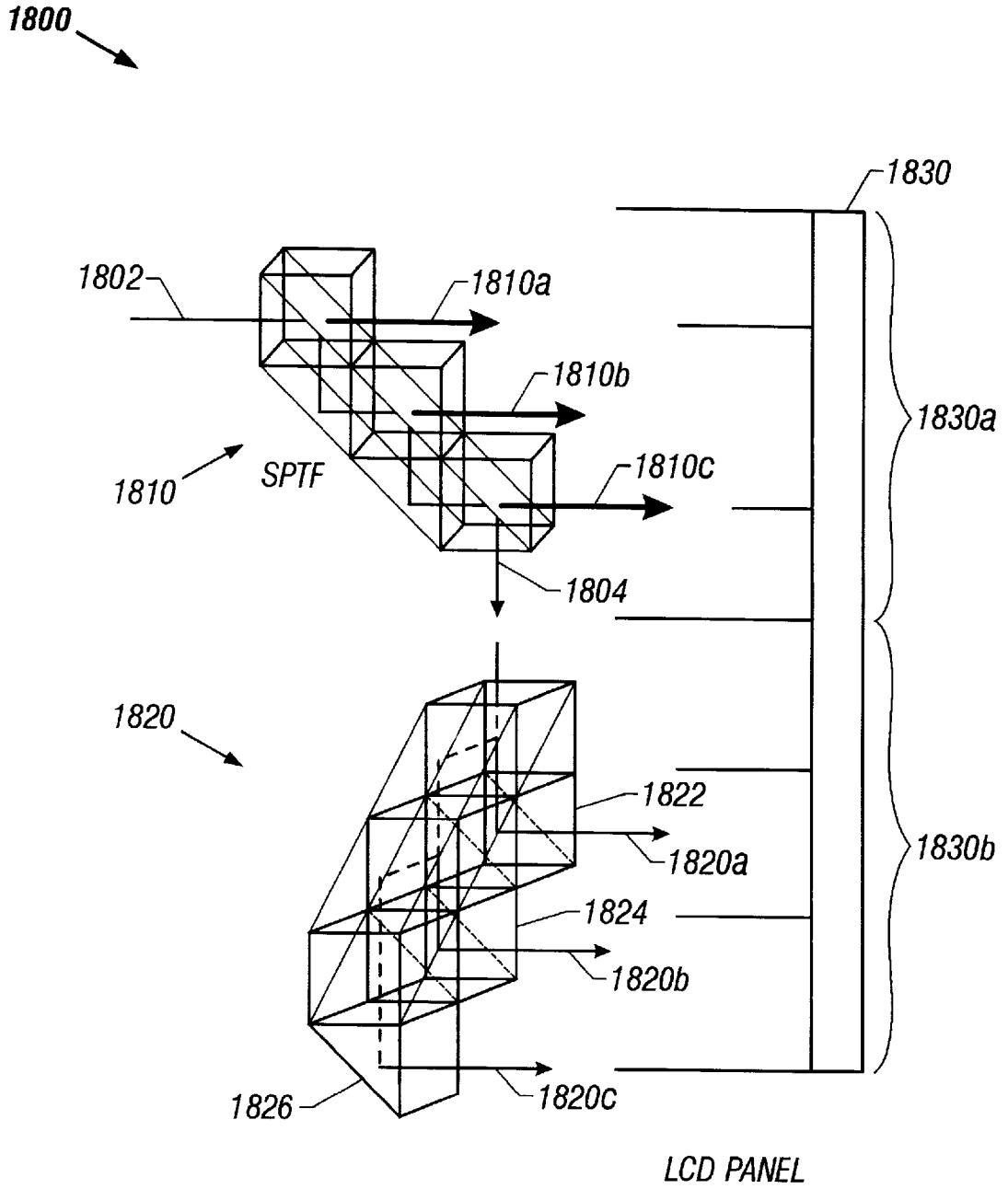

FIG. 18

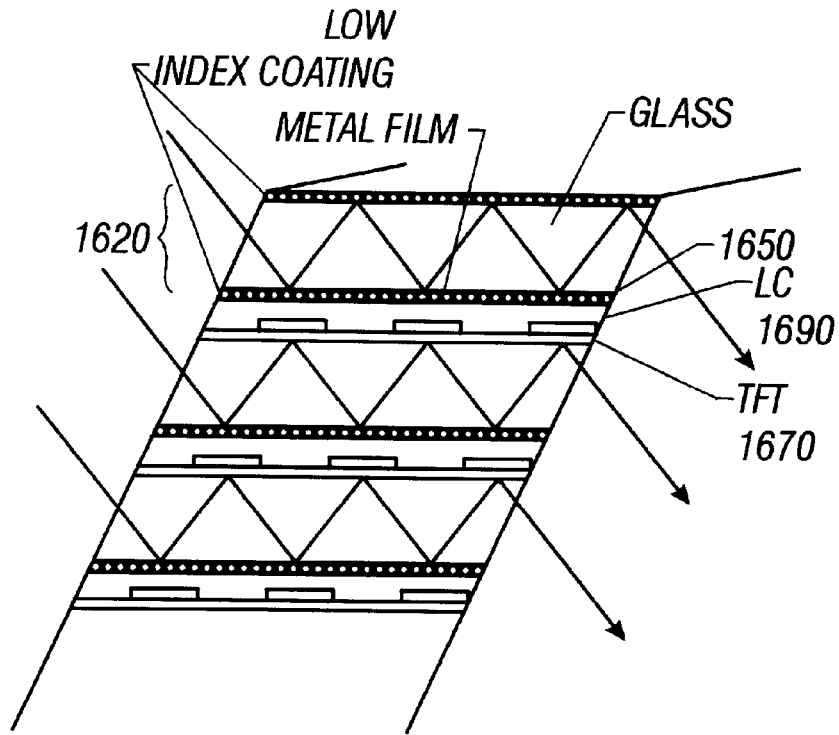

FIG. 19A

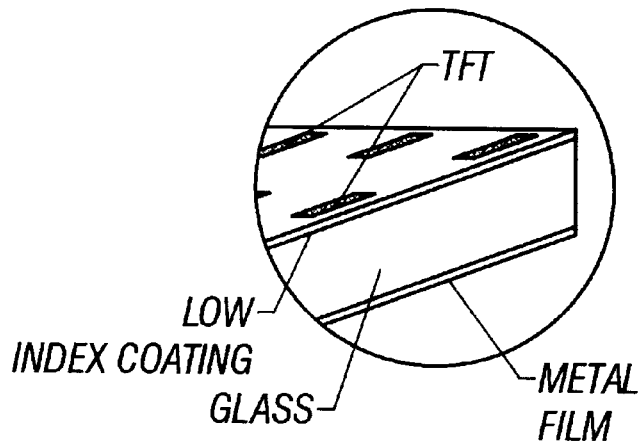

FIG. 19B

DEVICES BASED ON SURFACE PLASMON INTERFERENCE FILTERS

This application is a continuation-in-part of the U.S. patent application Ser. No. 08/949,151, filed on Oct. 10, 1997, now U.S. Pat. No. 5,986,808. This application further claims the benefit of the U.S. Provisional Application No. 60/056,050, filed on Sep. 2, 1997, No. 60/059,247, filed on Sep. 18, 1997, and No. 60/060,733, filed on Oct. 1, 1997.

ORIGIN OF THE INVENTION

The invention described herein was made in the performance of work under a NASA contract, and is subject to the provisions of Public Law 96-517 (35 U.S.C. 202) in which the Contractor has elected to retain title.

FIELD OF THE INVENTION

The present invention relates to wavelength tunable optical filters and, more particularly, to devices based on a surface plasmon tunable filter.

BACKGROUND

An optical wavelength filter is a device that reflects or transmits light of a desired wavelength or within a certain wavelength range. For example, an interference bandpass filter selectively transmits light within a selected wavelength transmission bandwidth while absorbing light of wavelengths outside the transmission bandwidth. Such optical filtering with respect to wavelength provides a means of controlling the energy and spectral composition of light and is widely used in a variety of optical signal processing, detection, and display applications.

Excitation of surface plasmon waves at a metal-dielectric interface has been demonstrated as an efficient way of implementing a spectral filtering mechanism in response to an electrical control signal. See, for example, Wang and Simon, "Electronic Reflection with Surface Plasmon," *Opt. Quantum Electron.* 25, S925 (1993) and Wang, "Voltage-Induced Color-Selective Absorption with Surface Plasmon", *Appl. Phys. Lett.* 67, pp. 2759-2761 (1995). Surface plasmon are oscillations of free electrons caused by resonant absorption of a p-polarized incident optical wave at a metal-dielectric interface when the wavelength and incident angle of the optical wave satisfy a plasmon resonance condition. More specifically, the plasmon resonance condition requires that the component of the optical wave vector along the metal-dielectric interface matches the plasmon wave vector, K_p :

$$K_p = \frac{2\pi}{\lambda} \sqrt{\frac{\epsilon_1 \epsilon_2}{\epsilon_1 + \epsilon_2}}, \quad (1)$$

where, λ is the wavelength of the optical wave, ϵ_1 and ϵ_2 are the dielectric permittivity constants for the metal and the dielectric material, respectively.

At surface plasmon resonance, the energy of the incident optical wave is strongly absorbed and converted into the energy of oscillating free electrons in the metal. Therefore, the reflected optical wave is strongly attenuated or even vanishes. When the incident angle of the optical wave is fixed at a constant, the optical wavelength λ satisfying the plasmon resonance condition may be changed by varying the dielectric permittivity constant ϵ_2 of the dielectric material. If the input optical wave is white light, the color of

the reflected optical wave will change with ϵ_2 . This phenomena effects a surface plasmon tunable filter in reflection mode.

Therefore, an electronically tunable filter can be formed by using an electro-optic material as the dielectric material. The voltage applied on the electro-optic material changes its index of refraction and thereby changes the wavelength for the surface plasmon resonance.

Wang and Simon disclose color display devices based on a surface plasmon filter using a liquid crystal electro-optic material. U.S. Pat. Nos. 5,451,980 and 5,570,139, which are incorporated herein by reference. The index of the refraction of the liquid crystal is changed by applying a voltage to alter the spectral composition of the reflected light.

SUMMARY

The devices disclosed herein use surface plasmon waves at metal-dielectric interfaces to alter the spectral composition of light having a p-polarized component. The metal material in general has a negative dielectric constant and the dielectric material has a positive dielectric constant. The electrical field of the p-polarized component at non-normal incidence induces electric dipoles in a metallic layer that forms one side of a metal-dielectric interface due to the excitation of the free electrons in the metal. The direction of the induced dipoles is perpendicular to the metal-dielectric interface. The radiation of the dipoles generates a surface plasmon wave with a wave vector parallel to the interface. The strength of the surface plasmon wave is maximal at the metal-dielectric interface and decays exponentially on both sides of the interface.

The energy conversion from the incident light to the surface plasmon wave is maximal when the incident angle, wavelength of the incident light, the dielectric constants of the metal and the dielectric materials satisfy a surface plasmon resonance condition. In general, this resonance condition relates to mode matching between the p-polarized incident light and the surface plasmon wave at a metal-dielectric interface and may vary with the specific incident coupling mechanism and the structure of the interfaces (e.g., a single interface or two closed coupled interfaces).

One embodiment of a surface plasmon filter includes a dielectric layer sandwiched between two metallic layers to form two closely spaced symmetrical metal-dielectric interfaces. The optical thickness of the dielectric layer is configured to allow for excitation of surface plasmon waves on both metal-dielectric interfaces by an input optical wave. The dielectric layer may be less or larger than one wavelength but in general on the order of a wavelength. The coupling between the surface plasmon waves produces a reflected wave and a transmitted wave that have mutually complimentary colors.

The surface plasmon resonance frequency can be tuned by adjusting the optical thickness of the dielectric layer. Either the layer thickness or the index of the refraction of the dielectric layer may be adjusted to change the transmission wavelength. One implementation uses an adjustable air gap as the dielectric layer. Another implementation uses a layer of an electro-optic material to vary the optical thickness by changing the index of refraction with a voltage control signal.

One or more additional metal-dielectric interfaces may be added and coupled to the two metal-dielectric interfaces to form a multilayer surface plasmon filter. Such a multilayer structure can be configured to achieve a desired shape in the transmission spectrum profile. For example, a "notch" filter

can be so formed to produce a square-like transition from a transmissive spectral region to a reflective spectral region and to achieve a desired transmissive bandwidth.

The surface plasmon filter can be used to form a wide range of devices. One such device is a tunable Fabry-Perot filter based on an air-gap surface plasmon filter. Various color filters for color display systems such as color LCD displays can be formed based on a surface plasmon filter.

These and other aspects and advantages of the present invention will become more apparent in light of the accompanying drawings, the detailed description, and the claims.

BRIEF DESCRIPTION OF THE DRAWINGS

FIG. 1A is a diagram showing one embodiment of the surface plasmon filter using a high-index material for light coupling.

FIG. 1B is a diagram showing another embodiment of the surface plasmon filter using a grating for light coupling.

FIG. 2 is diagram showing a surface plasmon filter using a layer of electro-optic material and high-index prisms.

FIG. 3A is a chart of calculated transmission spectrum of the surface plasmon filter of FIG. 2 using silver films under different changes in the index of refraction of the electro-optic layer.

FIG. 3B is a chart of calculated transmission spectrum of the surface plasmon filter of FIG. 2 using potassium films under different changes in the index of refraction of the electro-optic layer.

FIG. 4 is diagram showing a surface plasmon filter using an adjustable air gap and high-index prisms.

FIG. 5 is a chart of calculated transmission spectrum of the surface plasmon filter of FIG. 4 under different spacings of the air gap.

FIG. 6 is diagram showing a surface plasmon filter formed with two glass plates having micro-prisms arrays.

FIG. 7 is a chart of calculated transmission spectrum of the surface plasmon filter of FIG. 6 under different spacings of the air gap between the glass plates.

FIG. 8A is a block diagram showing a high-resolution spectrometer based on a Fabry-Perot filter and a surface plasmon filter.

FIG. 8B is a diagram illustrating integration of a surface plasmon filter and a sensor array.

FIG. 9 is a diagram of color LCD display based on a surface plasmon filter.

FIG. 10 is a diagram showing one embodiment of a multi-layer surface plasmon filter having six coupled metal-dielectric interfaces.

FIG. 11 shows calculated reflection spectrum of the filter of FIG. 10 with three identical liquid crystal layers of 185 nm thick, two outer silver films of 20 nm thick and two middle silver films of 40 nm thick.

FIG. 12 is a flowchart showing the design process of a multi-layer surface plasmon notch filter

FIG. 13A are plots showing exemplary colors that can be generated by different overlapping the reflection spectra of two tunable surface plasmon filters.

FIG. 13B is a diagram showing one embodiment of a reflective flat panel color display based on the technique shown in FIG. 13A.

FIG. 13C is a diagram showing one implementation of a reflective flat panel color display of FIG. 13B.

FIG. 14A is a diagram showing one embodiment of a color filtering device for producing sequential colors.

FIG. 14B F shows the reflectivity spectra of three filters based on a multi-layer design when illuminated by a white input beam.

FIG. 14C is a CIE diagram to show the color purity of the primary colors produced by the filters shown in FIG. 14B.

FIG. 15 is a diagram illustrating a color display system based on the filter of FIG. 14A.

FIG. 16A is a diagram showing an exemplary smart card image device based on surface plasmon filters.

FIG. 16B illustrates the manufacturing process of the smart card imaging device of FIG. 16A.

FIG. 16C is a diagram showing one design of addressing the transistors in the device of FIG. 16A.

FIGS. 17A, 17B, and 17C show structure and operation of one color filter using three surface plasmon tunable filters.

FIG. 18 shows another color filter based on the device of FIGS. 17A through 17C.

FIG. 19A shows an alternative construction of the pixel in the device of FIG. 16A, where only three layers are used to form a surface plasmon filter: a metal layer, a liquid crystal layer and a thin-film transistor layer.

FIG. 19B shows that each plate can be a simple high-index glass plate with one side formed with thin-film transistors and the other side coated with a metal layer.

DETAILED DESCRIPTION OF THE PREFERRED EMBODIMENTS

FIG. 1A shows one embodiment **100** of a coupled surface plasmon tunable filter. Two symmetrical metal-dielectric interfaces **110a** and **110b** are formed by sandwiching a dielectric layer **110** between two substantially identical metallic layers **120a** and **120b**. The metallic layers **120a** and **120b** are sufficiently thin so that the evanescent electromagnetic waves can penetrate the metallic layers **120a** and **120b**. The evanescent waves may be generated by, for example, an incident optical wave or coupling of oscillating electrical fields caused by surface plasmon waves. In general, the thickness of the metallic layers **120a** and **120b** may be any value. However, the preferred thickness is from about 5 nm to about 150 nm and most preferably from about 10 nm to about 100 nm. A variety of metals may be used for forming the layers **120a** and **120b**, including but not limited to, Ag, Al, Au, K, and Li.

The dielectric layer **110** may be any dielectric material, including air or an electro-optic material including inorganic crystals (e.g., KDP, KTP, LiNbO₄), polyimide guest-host materials, organic crystals (e.g., MMONS and MNA), organic salts, and liquid crystals. The thickness of the dielectric layer **110** is sufficiently thin to allow for efficient energy coupling between the first metallic-dielectric interface **110a** and the second metallic-dielectric interface **110b**. Preferably, the optical thickness of the dielectric layer **110** is on the order of a wavelength.

An incident optical wave **102** to the metallic layer **120a** can excite a surface plasmon wave at the first interface **110a** if the surface plasmon resonance condition is met. The energy of photons in the surface plasmon resonance is converted into collective oscillations of free electrons generated in the first metallic layer **120a**. This causes strong absorption of the photons at the resonant wavelength in the incident optical wave **102** and the unabsorbed photons are reflected as the reflected wave **104** from the first metallic layer **120a**.

The oscillating free electrons in the first metallic layer **120a** generate an evanescent optical wave at the wavelength

of the absorbed resonant photons. The field of the evanescent optical wave penetrates the thin dielectric layer **110** to reach the second metallic-dielectric interface **110b**. The field of the evanescent optical wave can excite a second surface plasmon wave on the second interface **110b**. This is at least in part due to the symmetry of the two interfaces **110a** and **110b** with respect to the dielectric layer **110**. The second surface plasmon wave is substantially identical to the first surface plasmon wave including the frequency and the plasmon wave vector. The oscillating free electrons in the second metallic layer **120b** radiate photons in the same direction and at the same frequency as the absorbed resonant photons at the first metallic layer **120a**. The radiated photons exit the second metallic layer **120b** as a transmitted wave **106** which is substantially parallel to the input beam **102**.

Therefore, for an incident light with a broad spectrum, the device **100** of FIG. 1 will couple the spectral component that satisfies the surface plasmon resonance condition to the second interface **110b** as the transmitted wave **106** and reflects the rest of the input light as the reflected wave **104**. In particular, a white input beam may be split into a colored transmitted beam and a reflected beam which is spectrally complimentary to the transmitted beam.

The excitation of the first surface plasmon wave at the first interface **110a** and the excitation of the second plasmon wave at the second interface **110b** are correlated. Under a surface plasmon resonance condition, the evanescent field pattern of the first surface plasmon wave in the dielectric layer **110** and the evanescent field pattern of the second surface plasmon wave affect each other to match the field patterns. The incident angle and wavelength of the incident optical wave **102** and the optical thickness of the dielectric layer **110** can be adjusted to satisfy the resonance condition in order to achieve simultaneous excitation of both the first and the second plasmon waves. The exact resonance condition can be determined by applying the Maxwell wave equations to each of the dielectric layer **110** and the two metallic layers **120a** and **120b** and by matching the boundary conditions at interfaces **110a** and **110b**.

For a given incident angle of the input optical wave **102**, the optical thickness of the dielectric layer **110** may be adjusted to achieve excitation of the surface plasmon waves at different wavelengths to effect color filtering in both transmitted beam **108** and the reflected beam **104**. The optical thickness of the dielectric layer **110** is the product of its index of refraction and the layer thickness. Therefore, the layer thickness of the dielectric layer **110**, or the index of refraction, or both may be varied in order to select different wavelengths to meet the resonance condition of surface plasmon waves at the interfaces **110a** and **110b**.

Referring to FIG. 1, the embodiment **100** further includes two identical dielectric layers **130a** and **130b** respectively formed on the metallic layers **120a** and **120b**. The index of the refraction of the layers **130a** and **130b** is larger than that of the dielectric layer **110** in order to properly couple the input optical beam **102** to excite surface plasmon waves. For example, a high-index prism (e.g., TiO_2) may be used to couple the input optical wave **102** at a specified incident angle. In general, the incident angle of the input optical wave **102** is larger than the critical angle for total reflection defined by the high-index layer **130a** (or **130b**) and the dielectric layer **110**.

The coupling dielectric layers **130a** and **130b** are usually in form of prisms and may be made of any dielectric material with an index of refraction higher than that of the dielectric layer **110**. Examples of suitable high-index materials include

glasses such as SF glass (e.g., SF6, SF57, SF 58, SF 59, etc.) and LaSF glass (e.g., LaSFN18, LaSFN31, LaSFN9, LaSF13, etc.), crystals such as TiO_2 , sapphire, diamond, and high-index polymers.

Alternatively, a grating may also be used for light coupling as shown in FIG. 1B. In this embodiment, two substantially identical gratings **140a** and **140b** substitute the high-index coupling dielectric layers (**130a** and **130b**). Each of the gratings **140a** and **140b** is coated with a layer of metal film (**150a** and **150b**) to form the metal-dielectric interfaces. The gratings **140a** and **140b** are configured to produce a diffracted order **102b** of the incident light **102** to have a wave vector parallel to the metal-dielectric interfaces. For example, the first-order diffraction beam may be used as the beam **102b** to excite a surface plasmon wave and the zero-order diffraction beam is reflected as the beam **102a**. Similar to the embodiment **100** of FIG. 1A, the coupling between the two symmetric interfaces produces the transmitted beam **106**.

In the case where a surface plasmon wave is excited at only one metal-dielectric interface, the resonance condition requires

$$\frac{2\pi}{\lambda} \sin\theta \pm \frac{2\pi}{d} \cdot p = K_p \quad (2)$$

where d is the grating period, p is an integer indicating the order of diffraction and K_p is the surface plasmon wave vector defined by Equation (1). For the coupled symmetric structure shown in FIG. 1B, the surface plasmon resonance condition is more complex than Equation (2) and can be similarly determined as in the embodiment **100** of FIG. 1A by applying the Maxwell wave equations to each of the dielectric layer **110** and the two metallic layers **150a** and **150b** and by matching the boundary conditions at the interfaces.

The gratings **140a** and **140b** may be implemented in a number of ways. For example, one way is to attach a separately-formed grating to the dielectric layer **110**; another way is to directly form a coupling grating on the dielectric layer **110**; yet another way is to etch a grating on the surface of the dielectric layer. The gratings **140a** and **140b** in first two examples are preferably made of a transparent material in the operating spectral range. A dielectric material may be used to form a support for the grating coupled filter of FIG. 1B.

One implementation of the embodiment **100** is shown in FIG. 2. A thin layer of electro-optic material **210** with a fixed thickness less than a wavelength is sandwiched between two thin metallic films **220a** and **220b**. A first prism **230a** is used as an input light coupling element by placing the hypotenuse in contact with the first thin metallic film **220a**. Symmetrically, a second prism **230b** identical to the **230a** is disposed on the second metallic film **220b** as an output light coupling element. The index of refraction of the prisms **230a** and **230b** is larger than that of the electro-optic material **210**. An electrical voltage supply **212** is connected to the electro-optic material **210** to provide an electrical control of its index of refraction.

The electro-optic material **210** may be any suitable electro-optic material including KDP, KTP, LiNbO_4 crystals or a liquid crystal material. The thin metallic films **220a** and **220b** may be made of silver, aluminum, or other metals with desired dispersion properties in the surface plasmon excitation. In the visible spectral range, metals such as Ag or Al may be used. In the IR range, Au and alkali metals such as

K or Li may be used. The prisms **230a** and **230b** may be made of a high-index glass as previously described.

The index of refraction of the electro-optic material **210** changes in response to a voltage control signal from source **212**. This index change further causes a change in the optical thickness of the electro-optic material **210**. Therefore, the surface plasmon resonance frequency and the transmission spectrum of the device **200** change accordingly.

FIG. **3A** is a chart showing the calculated transmission spectrum for two silver films separated by a 150-nm electro-optic material layer. The calculation is based on the Maxwell wave equations. The prisms are made of TiO₂ and the metallic films **220a** and **220b** are 35-nm silver films. The incident angle is fixed at 45°. When no voltage is applied, the index change dn is zero, and the peak transmission is about 62% at 450 nm (blue). When the voltage-induced index change of the electro-optic layer is $dn = 0.2$, the transmission peak shifts to 530 nm (green) with a transmission of about 73%. When the index increases by an amount of $dn = 0.5$, the peak transmission shifts to 650 nm (red) with a transmission of about 70%. Thus, all three primary colors (red, green and blue) can be achieved in the transmitted light by changing the index of the electro-optic layer by an amount in a range of from 0 to about 0.5.

The intensity and linewidth of a transmission peak in the filter **200** depend on the optical properties and the thickness of the metallic films **220a** and **220b**. Metals with small imaginary part of the dielectric constant usually lead to higher peak transmission and narrower bandwidth. A thinner metallic layer can be used to achieve greater peak transmission and broader bandwidth.

In addition, different operation spectral ranges may be achieved by using different metals for the metallic films **220a** and **220b**. For example, potassium films may be used to replace the silver films in the device of FIG. **2** to change the transmission spectrum from the visible range to the infrared (IR) range. FIG. **3B** shows that potassium films each of 900 Å are used to achieve a tunable IR spectral range from 1050 nm to 1700 nm range by varying the index of the electro-optic layer **210** by an amount in a range of from 0 to about 0.5, i.e., index varies from about 1.5 to about 2.0. The coupling prisms are made of TiO₂ and the incident angle is about 43°. This particular IR range covers the transmission windows near 1.3 μm and 1.5 μm for fiber communication systems.

Another implementation of the embodiment **100** is shown in FIG. **4** which replaces the electro-optic material **210** of FIG. **2** with an adjustable air gap **410** between the two prisms **230a** and **230b**. In this configuration, the metallic films **220a** and **220b** are respectively formed on the hypotenuses of the prisms. The metallic-dielectric interfaces along with the surface plasmon waves are excited are metal-air interfaces. The spacing between the metallic films **220a** and **220b** may be varied by a positioning device such as a piezo-electric transducer. FIG. **5** shows the calculated transmission spectrum of the device of FIG. **4** under different spacings of the air gap **410**. The calculation is based on an incident angle of 40°, silver films of 400 Å, and coupling prisms made of the BK7 glass. As the air gap **410** increases from about 200 nm to about 750 nm, the transmission peak shifts from about 400 nm to about 700 nm within the visible spectral range. Transmissions at other spectral ranges may also be achieved, for example, by using different metallic films **220a** and **220b**.

The filter configuration shown in FIG. **4** can be used to form a tunable color filter array by using two micro-prism plates. An example is shown in FIG. **6**. Two "T" shaped

glass plates **610** and **620** each have a plurality of micro-prisms **612** and **622** arranged in a one-dimensional or two-dimensional prism array on one side of the plates. The micro-prisms **612** and **622** may be formed by etching or other microprocessing techniques. A thin metal film layer is coated on the micro-prisms on each glass plate. The filter **600** is formed by placing the two glass plates **610** and **620** together with the micro-prism sides conforming with each other. Two adjustable spacers **630** (e.g., voltage-controlled piezo-electric spacers) are used to separate the two glass plates **610** and **620** by a thin air gap **640** between the micro-prisms **612** and **622**. Preferably, the thin air gap **640** is less than a wavelength. As the length of the spacers **630** is adjusted, the air gap **640** between the micro-prisms **612** and **622** changes. This results in a change in the surface plasmon resonance frequency and consequently a shift in the wavelength of the transmission spectrum.

FIG. **7** shows the calculated transmission of the device of FIG. **6** as a function of wavelength for various spacings of the air gap **640**. The calculation is based on silver films of 40 nm thick, an incident angle of 42.5°, and coupling prisms made of the BK7 glass. When the air gap **640** increases from 300 nm to 5000 nm, the peak reflectivity shifts from 400 nm to 1600 nm. The transmission peaks as labeled are: peak **710** at an air gap of 300 nm, peak **720** at an air gap of 800 nm, peak **730** at an air gap of 1500 nm, peak **740** at an air gap of 3000 nm, and peak **750** at an air gap of 5000 nm.

The air gap surface plasmon tunable filter shown in FIGS. **4** and **6** can be operated under a wide range of temperatures. For example, an operating temperature range from about -200° C. to +200° C. can be achieved by using piezo-electric spacers and choosing the prism glass to match the thermal expansion of the piezo-electric spacers.

Alternatively, the air gap **640** in the micro-prism surface plasmon filter **600** of FIG. **6** may be replaced by a layer of electro-optic material with a fixed thickness. The surface plasmon resonant frequency can be altered by electrically changing the index of refraction.

The above-described surface plasmon tunable filters may combine with a Fabry-Perot filter to form a high-resolution spectrometer as shown in FIG. **8A**. Fabry-Perot filters can be made to have a high fineness number to achieve high spectral resolution. However, the tuning range of many Fabry-Perot filters is limited. The spectrometer of FIG. **8A** has an advantage of the high resolution of the Fabry-Perot to filter and the wide tunable range of the surface plasmon filter.

FIG. **8B** shows another device based on the surface plasmon filter. This device combines the micro-prism surface plasmon filter **810** with a sensor array **820**. The micro-prism surface plasmon filter **810** has an active layer **812** which can be either an air gap or a layer of electro-optic material between two metallic films. The sensor array **820** may be any photodetector array including a CCD array, a diode array, a phototransistor array or an active pixel sensing array ("APS"). In operation, the surface plasmon filter **810** selects the transmission spectrum and the sensor array **820** measures the intensity of the incident pattern, respectively. As shown in FIG. **8A**, a Fabry-Perot filter may be added to the device of FIG. **8B** to enhance the spectral resolution.

In addition, the device of FIG. **8B** may be integrated on a single chip to form an image spectrometer-on-a-chip. In particular, an APS array may be used as the sensor array and the active layer **812** of the surface plasmon filter may be divided into many pixels to match the pixel size of the APS array. The pixel of the active layer **812** can be addressed by an active matrix and the spectrum of each pixel can be individually adjusted.

Furthermore, a surface plasmon filter can be used in either a projection or a direct-view color display system. FIG. 9 shows a back-lit color liquid crystal display (“LCD”) system 900 based on a prism-coupled surface plasmon filter 930. A light source 910 and a lens system 920 produce a white beam 922 with a substantially homogenous illumination profile. The light source 910 may be a lamp with a line-shaped filament and the lens system 920 may simply be a cylindrical lens. The surface plasmon filter 930 receives the white beam 922 and produces a beam 924. The color of the beam 924 is electrically controlled by the filter 930 using either an adjustable air gap or an electro-optic material. A reflector 940 further guides the filtered beam 924 to a monochromatic LCD panel 950. Preferably, the reflective surface of the reflector 940 has structures to make the reflected light diffusive in order to improve the homogeneity of the images.

The filter 930 is configured to operate in the visible spectral range from about 400 nm to about 750 nm. For example, the prisms may be made of TiO₂ and the metallic films may be made of silver. In addition, an electro-optic material with an index variation range of about 0.5 may be used to achieve all three additive primary colors (i.e., red, green and blue). FIG. 3A shows one possible spectral output of such a filter.

The filter 930 and the LCD panel 950 are controlled by a display control circuit 960. The filter 930 performs color filtering in the homogeneous illumination beam 924 and the LCD panel 950 modulates the intensity distribution of the beam 924 to form images. During each frame scanning in the LCD panel 950 (e.g., 60 frame scans per second), the control circuit 960 controls the filter 930 to change the color of the beam 924 three times by sequentially hopping through three primary colors. This process produces colored images. In many LCD color displays, three pixels are used to produce one image pixel and each pixel has a color filter to produce one of the three primary colors. Thus, the LCD display 900 of FIG. 9 eliminates the color filter in each pixel and can achieve the same resolution in the color images by using only one third of the active pixels in the conventional LCD color displays. In addition, the LCD display 900 can be used to achieve higher image resolution with the same number of active pixels in the LCD panel 950 as in a conventional LCD display.

The above surface plasmon filters having two coupled metal-dielectric interfaces usually produce narrow bandwidth in either reflection or transmission with a Gaussian-like spectral profile. In certain applications, a broad band filter is desirable.

For example, many display systems use a white light source to generate desired primary colors by color filtering. If the bandwidth of the color filters is very narrow, only a small fraction of energy near the desired primary color wavelengths is used and the rest is rejected. Although this may produce highly pure primary colors, the light utilization efficiency is low. For certain display applications that require high display brightness and low power consumption (e.g., portable computers), broad band color filters may be preferred.

A notch filter is an example of such a filter which has a relatively flat center transmission or reflection region and sharp cut-off edges. Four, six or more metal-dielectric interfaces may be coupled to form a multi-layer surface plasmon filter to achieve a “notch” spectral profile in transmission or reflection.

FIG. 10 shows one embodiment 1000 of a multi-layer surface plasmon filter having six metal-dielectric interfaces. Four metal films 1010a, 1010b, 1010c, 1010d and three

dielectric layers 1020a, 1020b, 1020c are alternatively stacked relative to one another to form six symmetric metal-dielectric interfaces. The metal films are sufficiently thin so that the evanescent electromagnetic waves can penetrate therethrough. The dielectric layers are also thin and have an optical thickness on the order of a wavelength.

As an example, the dielectric layers may be formed of an electro-optic material such as a liquid crystal. A voltage may be applied to the two outer metal films 1010a and 1010d to change the optical thickness of each of the three dielectric layers 1020a, 1020b, and 1020c. In this configuration, the device effects three capacitors connected in series. The electric fields in the dielectric layers are essentially the same. The applied voltage changes the index of refraction of each dielectric layer and thereby the optical thickness. This changes the transmission wavelength.

FIG. 11 shows calculated reflection spectrum of the filter 1000 having three identical liquid crystal layers of 185 nm thick, silver films 1010a and 1010d of 20 nm thick and silver films 1010b and 1010c of 40 nm thick. Reflection curve 1 represents the reflection spectrum for transmitting in blue-green region when no voltage is applied across the silver films 1010a and 1010d. When a voltage is applied to increase the optical thickness of each dielectric layer, the transmission window shifts toward a longer wavelength. Curves 2, 3, 4, and 5 respectively represent reflection spectra for an voltage-induced increase in the index for 0.1, 0.2, 0.3, and 0.4.

Comparing to the transmission profiles of surface plasmon filters having two coupled metal-dielectric interfaces (e.g., FIGS. 3A and 3B), the spectral profile of the multi-layer filter 1000 has a wider bandwidth and a relatively flat region in the central region of the reflection. Such profile can be achieved by properly configuring the dielectric layers and the metal films. In general, the flatness of the “valley” in the reflection spectrum or “peak” in the transmission spectrum can be improved by increasing the number of layers.

FIG. 12 is a flowchart showing the design process of a multi-layer surface plasmon notch filter. If a desired reflection or transmission profile is not achieved by modifying the thickness values of the dielectric layers and the metal layers, the number of layers may be further modified.

The tunable notch filter 1000 in FIG. 10 can be used to form a reflective flat panel display. Consider a color filtering device having two tunable notch filters F1 and F2 used in combination in reflection mode as shown in FIG. 13A. Each notch filter is configured to transmit a bandwidth that covers about two thirds of the visible spectrum. A unpolarized white beam can be polarized by using a polarizer so that the input beam to the first filter F1 is p-polarized. The first filter F1 filters the p-polarized input beam to produce a first reflected beam at a first wavelength determined by the voltage applied thereto. The second filter F2, disposed relative to the first filter to receive the first reflected beam as a p-polarized input, filters the first reflected beam to produce a second reflected beam. The reflections from these two notch filters F1 and F2 can be combined to produce any visible color and grey scale by controlling the applied voltages to shift the reflection spectral regions relative to each other.

Several examples for generating different colors and grey scales by using the above color filter device are illustrated in FIG. 13A. In the first chart in FIG. 13A, the notch filter F1 is tuned to transmit light from 400 nm to 600 nm and reflect red and other wavelengths while the notch filter F2 is tuned to transmit the IR spectrum and to reflect all visible light. This produces red light by reflecting a white beam off the notch filters F1 and F2. Different red grey scales can be

generated by shifting the filters F1 and F2 to partially overlap with each other with different degrees in the red region. For example, shifting the filter F2 toward the visible region while maintaining the filter F1 at the spectral position shown would reduce the brightness of the red. When the F2 is at a position to transmit green and red and reflect other colors, the reflection becomes black (no reflected light). If the transmission windows are completely shifted out of the visible region, the reflection is white.

The second and third charts in FIG. 13A show generation of green and blue colors, respectively, in the reflected light by using the two notch filters F1 and F2. The fourth chart in FIG. 13A shows a dark green color by partially overlapping the transmission windows in the green-yellow region (approximately from 500 nm to 600 nm).

The multi-layer surface plasmon filter 1000 shown in FIG. 10 can be used to form reflective flat panel color display. FIG. 13B depicts one embodiment. A prism array is formed of two layers of micro prisms 1310a and 1310b of a high-index optical material (e.g., plastic) that stack over each other and is used to provide proper optical coupling. The interface sections 1320 between two layers of micro prisms are formed with multi-layers of alternating metal films and electro-optical dielectric layers as shown in FIG. 10. Each interface section is applied with a control voltage so that the reflected wavelength can be independently controlled. A polarizing layer 1330 is formed on top of the prism array to select p-polarized light. The angle of the micro prisms is configured in such a way that a visible light beam incident in the normal direction to the prism array surface satisfies the surface plasmon resonance condition. In a preferred embodiment, the prism angle is near or at 45° as shown.

Two adjacent interface sections define one color pixel 1340. An incident ray 1350 is reflected by the two interface sections to exhibit a desired color and grey scale when their transmission windows are tuned at proper spectral positions.

FIG. 13C shows one example of actual color display device based on the embodiment shown in FIG. 13B. A microlens array 1360 is disposed between the polarization layer 1330 and the micropism array to increase the viewing angle. Each microlens in the array 1360 is located to cover one color pixel. An opaque mask 1370 with an array of apertures can be placed at or near the focal plane of the microlens array 1360. The apertures are aligned with the pixels. In operation, light incident on each pixel is collimated by the respective microlens and then reflected twice in that pixel to obtain color and grey scale, and finally is spread to a divergent beam by the same microlens to form a large viewing angle. A slant incident ray 1380, for example, is refracted by a corresponding microlens and is reflected back to another direction as a ray 1382.

The reflective flat panel color displays in FIGS. 13B and 13C can use ambient light for illumination. Reflected light at a wavelength satisfying the resonance condition of the surface plasmon filter can be nearly completely reflected to achieve a high efficiency.

Such reflective color displays provide an alternative to the conventional color LCD displays widely used in notebook computers and other portable devices. A color LCD display such as the active matrix LCD in a notebook computer consumes a large portion of the power supply (e.g., as high as 80%). Use of the surface plasmon reflective display can significantly reduce power consumption and extend the actual operating time of a portable device such as a notebook computer when powered by a battery.

Another application of the surface plasmon filters is to form a tunable color filtering device to produce sequential colors for projectors using white light sources for illumination.

FIG. 14A shows one embodiment 1400 of such a tunable color filtering device. Three surface plasmon filters 1410, 1420, and 1430 are arranged relative to one another to sequentially reflect an incident white beam 1440 from the first filter 1410 to the second filter 1420 and to the third filter 1430. The first and third filters 1410 and 1430 are placed in a plane 1404 and are displaced from each other. The second filter 1420 is placed to face the plane 1404 in a position to reflect light from the first filter 1410 to the third filter 1430. A high-index optical material 1402 is filled between the filters 1410, 1420, and 1430 to provide proper optical coupling similar to the high-index prisms used in above surface plasmon filters. Since p-polarized light is needed to excite surface plasmon waves in each filter, a polarizer can be placed in the input path of filter 1410 to ensure that only p-polarized light enters the device 1400.

For a given filter, if the transmission window is set for a selected color, the reflection of a white incident light is the complementary color of that selected color. Each filter can be configured to satisfy a surface plasmon resonance to transmit a selected primary color when no voltage is applied. In addition, a proper voltage can be applied to the filter to destroy the resonance condition so that the filter becomes completely reflective in the entire visible spectrum. Hence, each filter can be configured to have two states: an "on" state to transmit a selected primary color and reflect other colors when no voltage is applied, and an "off" state when a voltage is applied to reflect all visible colors.

A notch surface plasmon filter as shown in FIG. 10 can be used for this purpose. The multi-layers of alternating metal films and dielectric layers can be configured to have a transmission window at a primary color (e.g., red, green, or blue) with a bandwidth of about one third of the visible spectrum without an external voltage. A voltage can be used to shift the transmission window out of the visible spectrum to generate the "off" state so the filter behaves like a mirror.

Referring to FIG. 14A, the three filters 1410, 1420, and 1430 can be designed to transmit red, green, and blue when no voltage is applied, respectively. Therefore, when a white light beam is sent in and no voltage is applied to any of the filter, the red portion is lost by reflection at the first filter 1410, the green portion is lost by reflection at the second filter 1420, and the blue portion is lost by reflection at the third filter 1430. Hence, no light comes out. This produces a "black" color. To produce a white output, a proper voltage is applied to each of the filters to turn "off" the transmission of each filter so that all filters become reflective, like mirrors. The transmitted colored light in each filter can be absorbed by using a light absorbing material. For example, a semiconductor substrate can be used to function as both a light absorber and a heat dissipator. An additional heat absorber may be used to further extract the heat from the light absorbing material.

An output with a primary color can be produced, therefore, by applying voltages only to two of the filters and applying no voltage to the remaining filter. The output color, therefore, is the primary color of the filter without voltage. A sequence of three primary colors can be generated by sequentially turning on and off voltages on the filters. For example, a red output can be produced by applying voltage to the first filter 1410 to turn off the transmission in the visible range while applying no voltage to the filters 1420 and 1430. When a voltage is applied to the second filter 1420 and no voltage is applied to the filters 1410 and 1430, the output is green. A blue output can be generated by applying voltage only to the third filter 1430.

This allows for a full color display. The switching rate for each filter should be at least three times of the frame rate, e.g., 180 Hz for a 60-Hz frame rate.

Such a color filtering device can be used to replace a color wheel to produce colors with a high efficiency. Since there are no moving parts, such a filter is generally more reliable than a color wheel and simplifies the display structure.

FIG. 14B shows the reflectivity spectra of three filters based on a multi-layer design when illuminated by a white input beam. The complementary colors cyan, magenta, and yellow of the primary additive colors red, green, and blue are respectively produced. The incident white beam has a half cone angle of about 6.7° and a contrast ratio up to and greater than 200:1 can be obtained with a liquid crystal material as the electro-optic material in the multi-layer construction. FIG. 14C is a CIE diagram to show the color purity of the primary colors produced by the filters shown in FIG. 14B. The color triangle formed by heavy lines represents colors that can be produced by the surface plasmon device. The colors that can be produced by a 27" CRT are indicated by a color triangle of light lines for comparison. The natural colors are also shown.

A spatial light modulator can be combined with the filtering device 1400 in FIG. 14A to modulate the intensity of the filtered output and to produce color images. FIG. 15 shows one embodiment 1500 of such a full-color display system. A spatial light modulator 1560 such as a LCD panel is implemented. Since the colors are sequentially produced, there is no need to use three adjacent pixels in the light modulator 1560 to produce a color pixel. Each pixel forms a color pixel. This increases the image resolution. A white light source such as a lamp 1510 is used for illumination. A suitable reflector 1520 is used to direct and collimate the light. An optical relay element 1530 (e.g., a lens) couples the light from the reflector 120 to the color filters 1410, 1420, and 1430. An optical integrator 1540 is used to improve the uniformity of the intensity across the beam. A polarizer 1550 ensures the light incident to the filters is p-polarized. A projection lens 1570 is used to project the output color images to a screen for viewing in either front projection mode or back projection mode.

The device shown in FIG. 14A may be modified to form a special flat panel display, a "smart card" image device having an array of active pixels each capable of producing colors and intensity modulation. FIG. 16A shows an exemplary smart card image device 1600 having an input surface 1610 and an output surface 1612. Each pixel 1620 is formed of a high-index dielectric material such as a high-index glass 1630 to form a light-conducting channel to guide light from the input surface 1610 to the output surface 1612.

The light-conducting channel has two parallel surfaces 1640 and 1650. The surface 1640 is coated with either a dielectric material with an index less than that of the dielectric material 1630 to confine light within the channel by total internal reflection or a reflective coating (e.g., metal) to reflect the light back into the channel. The surface 1650 is a metallic layer to form the first metallic side of coupled multi-layer metal-dielectric interfaces 1660 that form a surface plasmon tunable filter 1670 according to the notch filter shown in FIG. 10.

Each metal layer is patterned into three separate sections along the light conducting channel so that two adjacent metal sections in each metal layer are insulated from each other. This structure effects three independent coupled multi-layer surface plasmon filters.

A thin-film transistor layer 1670 with multiple thin-film transistors ("TFTs") is formed on the other side of the multi-layer 1660 to provide control voltages to the filters. Three TFTs 1672a, 1672b, and 1672c are shown to respectively control voltages to the three filters formed in the

multi-layer structure 1660. The metal layer 1650 is a common electrode for all three filters and may be set at a fixed potential or grounded. Each control voltage supplied by a respective TFT shifts the transmission window in a way similar to the filtering operations shown in FIG. 11. This changes the spectral composition of the beam reflected off that filter.

In the embodiment 1600, an incident light beam is reflected six times within the light conducting channel, three times by the surface 1640 and three times by the filters 1660, before exiting the output surface 1612. The intensity (i.e., grey scale) and color (i.e., spectral composition) of the output light beam are determined by the spectral positions of the three transmission windows of the filters. Similar to the filtering operations by successive reflections from two multi-layer surface plasmon filters shown in FIG. 13A, the relative spectral positions of the three transmission windows determine the color of the output beam and the amount of the overlap of the transmission windows produces different grey scales. At least two filters are needed in each light conducting channel to provide full color and intensity modulation. In general, increasing the number of filters in each conducting channel can increase the number of grey scales and the colors.

FIG. 16B illustrates the manufacturing process of the smart card imaging device 1600. First, a thin plate is formed, by known techniques, to include the layers 1640, 1630, 1650, 1660, and 1670 shown in FIG. 16A. Then, a multiplicity of such plates are stacked and attached together by using, e.g., a suitable adhesive. Insulating spacer layers may be used between the plates. The stack is sliced at a desired angle and polished to produce multiple smart cards.

If liquid crystal is used as the electro-optical material, the layer 1660 is formed with thin chambers for filling the liquid crystal. After slicing, the chambers in each card are filled with liquid crystal and sealed.

The above smart card device uses the surface plasmon filters to form color images without color separation and color fusing. Only one projection is needed to image the output beams from the output surface to a screen. This provides an efficient display with a simple structure.

Such smart card device requires addressing a TFT array in a three dimension space since at least two TFTs are required in the direction perpendicular to the card surface. For a smart card with VGA resolution, at least $480 \times 640 \times 2$ TFTs need to be addressed. FIG. 16C shows one design for addressing the TFTs. The connection of the row lines are straight and can be done with known techniques. The column lines are formed by thin metal strips that run through the output surface 1612. Such thin metal strips do not significantly affect the efficiency since the scattered light from the strips is generally in the forward direction.

One application of the such smart card device is the direct-view flat panel display by placing a screen at the output surface. The stack structure of the smart card device eliminate many limitations in the direct-view LCD displays such as the glass flatness and the liquid crystal layer uniformity. Hence, large-size direct-view flat panel displays exceeding 30" can be made using such technology.

Sequential light filters, such as color wheels and the device shown in FIG. 14A, transmit one color at a time. Hence, about two thirds of the energy of an input white beam is lost. Such loss of light energy can be avoided by combining three surface plasmon tunable filters to form a color generating device 1700 as shown in FIG. 17A.

Three prism-coupled surface plasmon tunable filters 1710, 1720, and 1730 are displaced from one another to

generate three primary output colors from a white input beam **1702**. Two reflectors **1740** and **1750** such as prisms are respectively placed between the filters **1710** and **1720** and between the filters **1720** and **1730** to direct the reflected beam from the filter **1710** to the filter **1720** and the reflected beam from the filter **1720** to the reflector **1730**. Preferably, each filter is a multi-layer surface plasmon filter as shown in FIG. **10** and has a tunable transmission window with a bandwidth about one third of the visible spectral range.

In operation, the three filters **1710**, **1720**, and **1730** are applied with different voltages to respectively transmit at three different primary colors. When the white input beam **1702** is p-polarized, the first primary color component is transmitted as a first transmitted beam **1702a** at the first filter **1710** and the remaining is reflected and directed to the second filter **1720** as a p-polarized beam **1702b**. The second filter **1720** transmits the second primary component color as beam **1703a** and reflects the rest to the third filter **1730** as beam **1703b**. The beam **1703b** is essentially comprised of the third primary component and is transmitted through the third filter **1730** as beam **1704a** to produce the third primary color.

Hence, at any moment, the device **1700** produces three different primary colors. Each image frame has three fields with different colors. To produce color images, the voltage on each filter is scrolled to sequentially produce three different primary colors at a rate three times of the frame rate. Thus, in a single frame, each of the three primary colors is scrolled through all three filters once. FIGS. **17A**, **17B**, and **17C** show one cycle of such color scrolling in a frame.

Similar to the color display system shown in FIG. **15**, a spatial light modulator such as a LCD panel only needs one pixel to produce all three colors. This eliminates the need for expensive miniaturized color filters and the requirement of using three pixels to form one color pixel as in many conventional LCD displays. Hence, using the device in FIG. **17** can improve image resolution, simplify device structure, and reduce manufacturing cost. Since all colors are used, the efficiency of such device is increased by a factor of 3 over many conventional LCD color displays.

All visible light in the p-polarized input is utilized in the device **1700**. However, if the input white beam **1702** is unpolarized like in many lamp sources, only the p-polarized portion in the visible range is used for image display and the other half of s-polarized light is rejected as an output beam **1704b**. FIG. **18** illustrates a surface plasmon device **1800** capable of using all visible energy of a unpolarized white input beam.

The device **1800** combines two devices **1810** and **1820** as shown in FIG. **17A** to achieve the above purpose. The device **1820** is rotated with respect to the device **1810** in such a way that the rejected s-polarized light by the device **1810** enters the device **1820** as p-polarized light. The device **1810** is used to produce one half (e.g., **1830a**) of a display **1830** and the device **1820** is used to produce the other half (e.g., **1830b**). Alternatively, the output beams of the two devices **1810** and **1820** may be overlapped to produce a display.

In the embodiment shown in FIG. **18**, the device **1820** is formed by a device identical to the device **1810** but is rotated 90° so that a s-polarized light with respect to the device **1810** becomes p-polarized in device **1820**. In addition, three reflectors (e.g., prisms) **1822**, **1824**, and **1826** are added to respectively direct the transmitted light in each filter in the device **1820** in a direction perpendicular to the respective incidence plane so that the output beams **1820a**, **1820b**, **1820c** from the device **1820** are parallel to the output beams **1810a**, **1810b**, **1810c** from the device **1810**. Since not only

all three colors are used but also both polarizations are used, the device **1800** can achieve an efficiency by a factor of 6 over many conventional LCD color displays.

Although the present invention has been described in detail with reference to the preferred embodiments, various modifications and enhancements may be made. For example, the coupling prisms, e.g., prisms **230a** and **230b**, may be made with angles other than an apex angle of 90° as illustrated; a polarizing element may be disposed in the path of the incident beam to change the input polarization to the p-polarization; the surface plasmon filter **930** in the LCD display may be grating coupled or have a micro-prism configuration; the LCD panel **950** may a digital mirror array. In addition, the air gaps may be a gap with a gas other than the air.

For another example, although all the embodiments disclosed change either the thickness or the index of refraction of the center dielectric layer to tune the transmission wavelength, the incident angle of the input light may also be adjusted to change the surface plasmon resonance condition, thereby changing the transmission wavelength. The incident angle may be changed with an angle adjustment device by either adjusting the direction of the input beam or adjusting the orientation of the surface plasmon filter relative to the input beam. In implementation of such angular tuning scheme, the index of refraction and the spacing between the two metal-dielectric interfaces may be fixed so that the incident angle is the only tuning parameter. Alternatively, the incident angle and either or both of the index of refraction and the spacing between the two metal-dielectric interfaces may be adjusted to tune the transmission wavelength.

In various color filtering and display applications, coupled multilayer surface plasmon filters such as the one in FIG. **10** are used to take the advantages of the square-like notch transmission window and the configurable transmission bandwidth obtained from proper configurations of the multiple metal-dielectric layers. However, the non-coupled absorbing surface plasmon filters having a single metal-dielectric layer as disclosed in the incorporated U.S. Pat. Nos. 5,570,139 and 5,451,980 can also be used. Although configuring the metal layer by combining different metal films can only offer limited flexibility in changing the absorption spectral profile, the simplicity in the structure of such filters provides easy construction of many of the above devices.

For example, if the surface plasmon filters in the devices of FIG. **13** are implemented by non-coupled surface plasmon filters, there is no need to eliminate the unwanted transmitted light since. In forming the device **1600**, each pixel **1620** can be significantly simplified by using such non-coupled surface plasmon filters. FIG. **19A** shows such an alternative construction of the pixel **1620**. Only three layers are needed to form each filter: a metal layer **1650**, a liquid crystal layer **1690** and the TFT layer **1670**. This simplifies the manufacturing of each plate for forming the stack. FIG. **19B** shows that each plate can be a simple high-index glass plate with one side formed with TFTs and the other side coated with a metal layer. Such plates are spaced by spacers when forming the stack so that the liquid crystal can be filled in the space provided by the spacers after slicing.

These and other variations and modifications are intended to be encompassed by the appended claims.

What is claimed is:

1. An optical device, comprising:

a first array of prisms formed of a transparent material, each prism having at least a first prism facet and a

second prism facet intersecting said first prism facet at a prism apex;

at least one metal layer and an electro-optical dielectric layer contacting each other to form a metal-dielectric interface on each prism facet, wherein said dielectric layer has a refractive index less than a refractive index of said first and second arrays of prisms, and wherein said metal-dielectric interface generates a surface plasmon wave in response to a p-polarized input light beam to transmit light at a selected wavelength within a bandwidth according to a control voltage from said metal layer to said dielectric layer and reflects light of other wavelengths; and

a second array of prisms substantially identical to said first array, disposed to engage to said first array in such a way that each prism facet in said second array conformably contacts said metal-dielectric interface formed on a respective prism facet of said first array, wherein said second array couples an input light beam to said metal-dielectric interface and the said first and second arrays are configured so that said input light beam is respectively reflected once by metal-dielectric interfaces on two adjacent prism facets of said first array to produce a desired color and a desired grey scale.

2. The device as in claim 1, further comprising a polarization layer disposed relative to said second array.

3. The device as in claim 2, further comprising a lens array disposed between said polarization layer and said second array, wherein each lens in said lens array is positioned over two adjacent prism facets of two different prisms in said first array.

4. A device, comprising,

a first tunable optical filter disposed to receive an input light beam to produce a first reflected beam and configured to include at least one metal layer and one electro-optical dielectric layer which form a metal-dielectric interface to generate a surface plasmon wave in response to a p-polarized input beam to transmit light at a first selected wavelength within a first bandwidth according to a first control voltage and to reflect light at other wavelengths;

a second tunable optical filter disposed relative to said first tunable optical filter to receive said first reflected light beam, said second tunable optical filter having at least one metal layer and one electro-optical dielectric layer to form a metal-dielectric interface that generates a surface plasmon wave in response to a p-polarized input beam to transmit light at a second selected wavelength within a second bandwidth according to a second control voltage and to reflect light at other wavelengths,

wherein said second optical filter reflects said first reflected light beam to produce a second reflected light beam with a selected color different than a color of said input light beam, and

wherein each of said first and second tunable optical filters comprises:

a first coupling element having a first coupling surface and operable to couple a p-polarized input electromagnetic wave to have a propagation component parallel to said first coupling surface;

a first metallic film formed on said first coupling surface and operable to produce free electron oscil-

lations in response to excitation of said p-polarized input electromagnetic wave, wherein said first metallic film is configured to allow penetration of evanescent fields;

a first dielectric layer having a first surface in direct contact with said first metallic film to form a first metal-dielectric interface and a second surface opposing said first surface;

a second metallic film substantially identical to said first metallic film and formed on said second surface of said first dielectric layer to form a second metal-dielectric interface that is substantially symmetric to said first metal-dielectric interface with respect to said first dielectric layer;

a second dielectric layer having a first surface in direct contact with said second metallic film to form a third metal-dielectric interface and a second surface opposing said first surface;

a third metallic film substantially identical to said second and first metallic films and formed on said second surface of said second dielectric layer to form a fourth metal-dielectric interface that is substantially symmetric to said third metal-dielectric interface with respect to said second dielectric layer; and

a second light coupling element configured to have a second coupling surface which is in direct contact with said third metallic film and operable to couple an electromagnetic wave propagating in said third metallic film along said second coupling surface into an output electromagnetic wave,

wherein said first, second, third, and fourth metal-dielectric interfaces are operable to support surface plasmon waves and to transfer energy of a selected spectral component in said p-polarized input electromagnetic wave from said first coupling surface to said second coupling surface by coupling a selected surface plasmon mode on said first metal-dielectric interface to said fourth metal-dielectric interface.

5. The device as in claim 4, wherein said first and second dielectric layers are formed of an electro-optic material and said first and third metallic films are applied with different voltages to change an optical thickness of said dielectric layers to tune a center wavelength of said selected spectral component.

6. The device as in claim 4, wherein said first and second dielectric layers have a thickness on the order of about one wavelength of said input electromagnetic wave.

7. The device as in claim 4, wherein said first and second coupling elements comprise prisms which are made of a dielectric material having a dielectric constant higher than a dielectric constant of said first and second dielectric layers.

8. The device as in claim 4, further comprising a spatial light modulator positioned to receive said second reflected beam from said second optical filter, said spatial light modulator having an array of light-modulating pixels to modulate said second reflected beam to produce an image.

9. The device as in claim 8, wherein said spatial light modulator includes a liquid crystal panel.

10. The device as in claim 4, further comprising an optical integrator positioned in an optical path of said input light beam to increase uniformity of a spatial intensity distribution of said input light beam.