



US006304040B1

(12) **United States Patent**
Cardwell, Jr. et al.

(10) **Patent No.:** **US 6,304,040 B1**
(45) **Date of Patent:** **Oct. 16, 2001**

- (54) **STARTER CIRCUIT FOR AN ION ENGINE**
- (75) Inventors: **Gilbert I. Cardwell, Jr.**, Palos Verdes Peninsula; **Thomas K. Phelps**, Torrance, both of CA (US)
- (73) Assignee: **Hughes Electronics Corporation**, El Segundo, CA (US)
- (*) Notice: Subject to any disclaimer, the term of this patent is extended or adjusted under 35 U.S.C. 154(b) by 0 days.

5,666,278	9/1997	Ng, et al.	363/71
5,852,555	12/1998	Martin	363/71
5,862,041	1/1999	Martin	363/71
5,862,042	1/1999	Jiang	363/71
5,875,103	2/1999	Bhagwat et al.	363/71
5,923,549	7/1999	Kobayashi et al.	363/71
5,930,122	7/1999	Moriguchi et al.	363/71
5,949,668	9/1999	Schweighofer	363/71
5,991,179	11/1999	Schweighofer	363/71
6,154,383	* 11/2000	Cardwell, Jr.	363/71
6,181,585	* 1/2001	Cardwell, Jr. et al.	363/71

- (21) Appl. No.: **09/352,011**
- (22) Filed: **Jul. 12, 1999**
- (51) **Int. Cl.⁷** **H05B 37/00**
- (52) **U.S. Cl.** **315/290**; 315/289; 315/291; 60/39.03
- (58) **Field of Search** 315/291, 224, 315/307, 111.21, 111.51, 289, 290, DIG. 5; 60/39.03; 361/247, 263; 363/41

OTHER PUBLICATIONS

Thomas A. Bond et al., "NSTAR Ion Engine Power Processor Unit Performance: Ground Test and Flight Experience", SAE Paper 99APSC-47, Apr. 1999.

Thomas A. Bond et al., "The NSTAR Ion Propulsion Subsystem for DS1", AIAA Joint Propulsion Conference, AIAA Paper 99-2972, Jun. 23, 1999.

John A. Hamley et al., "The Design and Performance Characteristics of the NSTAR PPU and DCIU", AIAA/ASME/SAE/ASEE Joint Propulsion Conference & Exhibit, 34th, Cleveland, OH, Jul. 13-15, 1998, AIAA Paper 98-3938.

* cited by examiner

Primary Examiner—Haissa Philogene
(74) *Attorney, Agent, or Firm*—Terje Gudmestad

(56) **References Cited**

U.S. PATENT DOCUMENTS

3,491,250	1/1970	Shoh	363/71
4,533,836	8/1985	Carpenter et al.	363/17
4,695,933	9/1987	Nguyen et al.	363/71
4,733,137	* 3/1988	Dunham	315/291
4,825,646	5/1989	Challoner, et al.	60/202
5,269,131	12/1993	Brophy	315/111.01 X
5,369,953	12/1994	Brophy	315/111.01 X
5,434,770	7/1995	Driefuerst et al.	363/71
5,451,962	9/1995	Steigerwald	363/17
5,561,350	* 10/1996	Frus et al.	315/209 R
5,576,940	11/1996	Steigerwald et al.	363/17
5,610,452	3/1997	Shimer et al.	307/89
5,657,217	8/1997	Watanabe, et al.	363/71

(57) **ABSTRACT**

A starter circuit particularly suitable for a plasma of an ion engine for a spacecraft includes a power supply having an output inductor with a tap. A switch is coupled to the tap. The switch has a control input. A pulse control logic circuit is coupled to said control input, said pulse control logic circuit controlling said switch to an off state to generate a high voltage discharge.

7 Claims, 3 Drawing Sheets

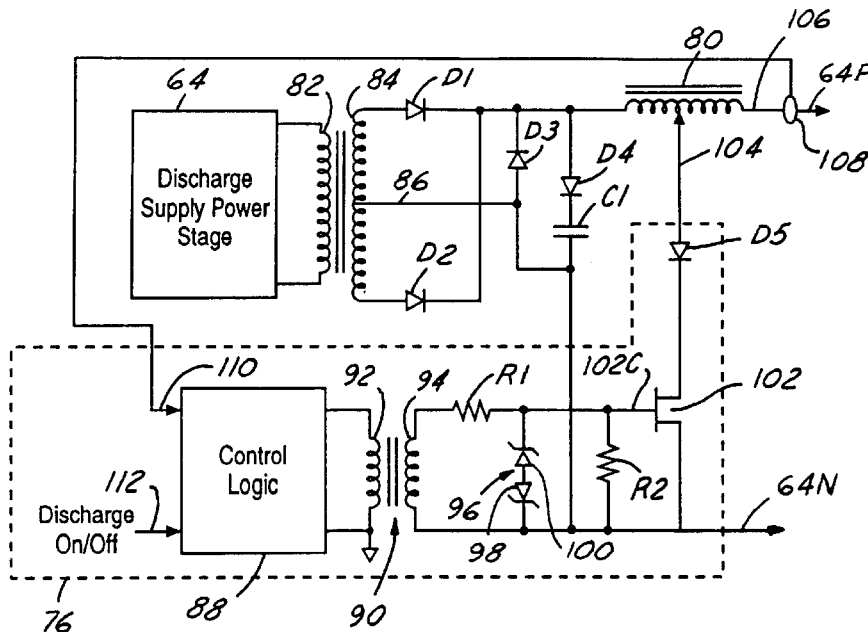

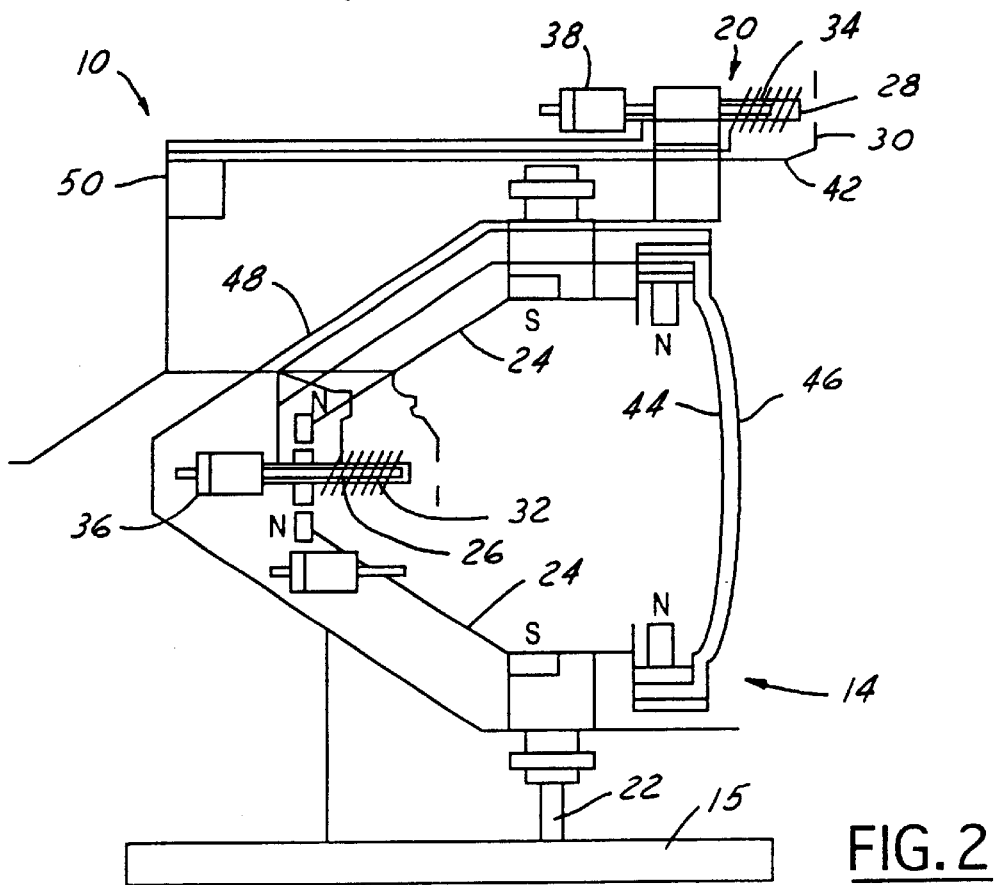
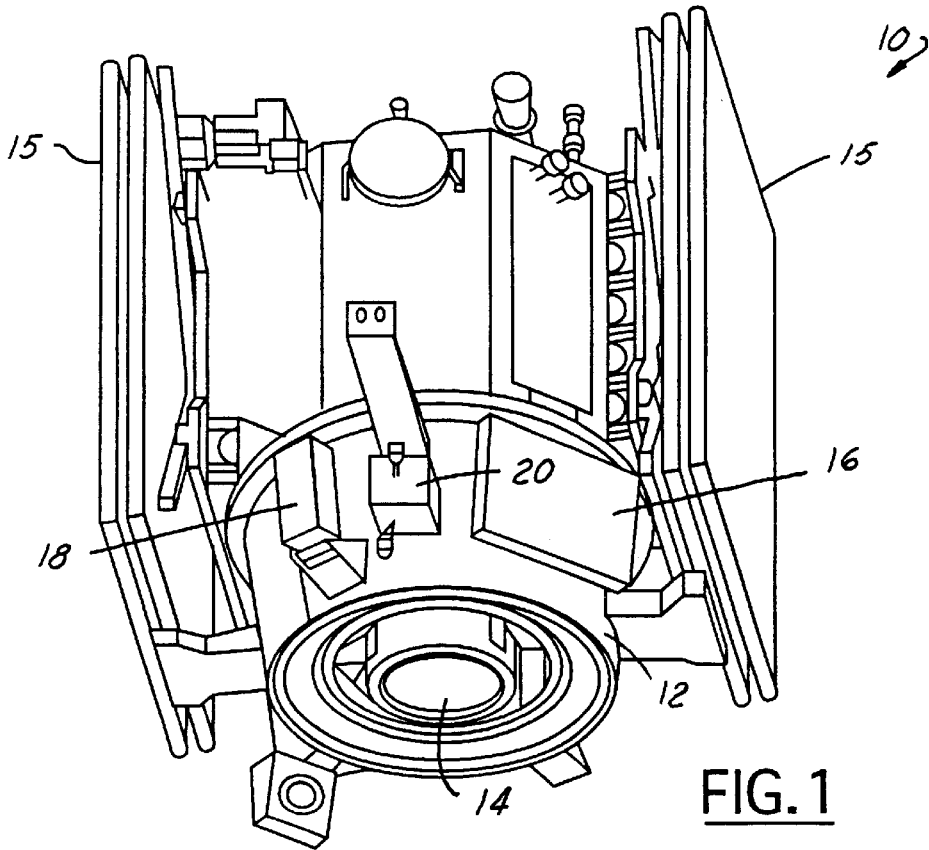

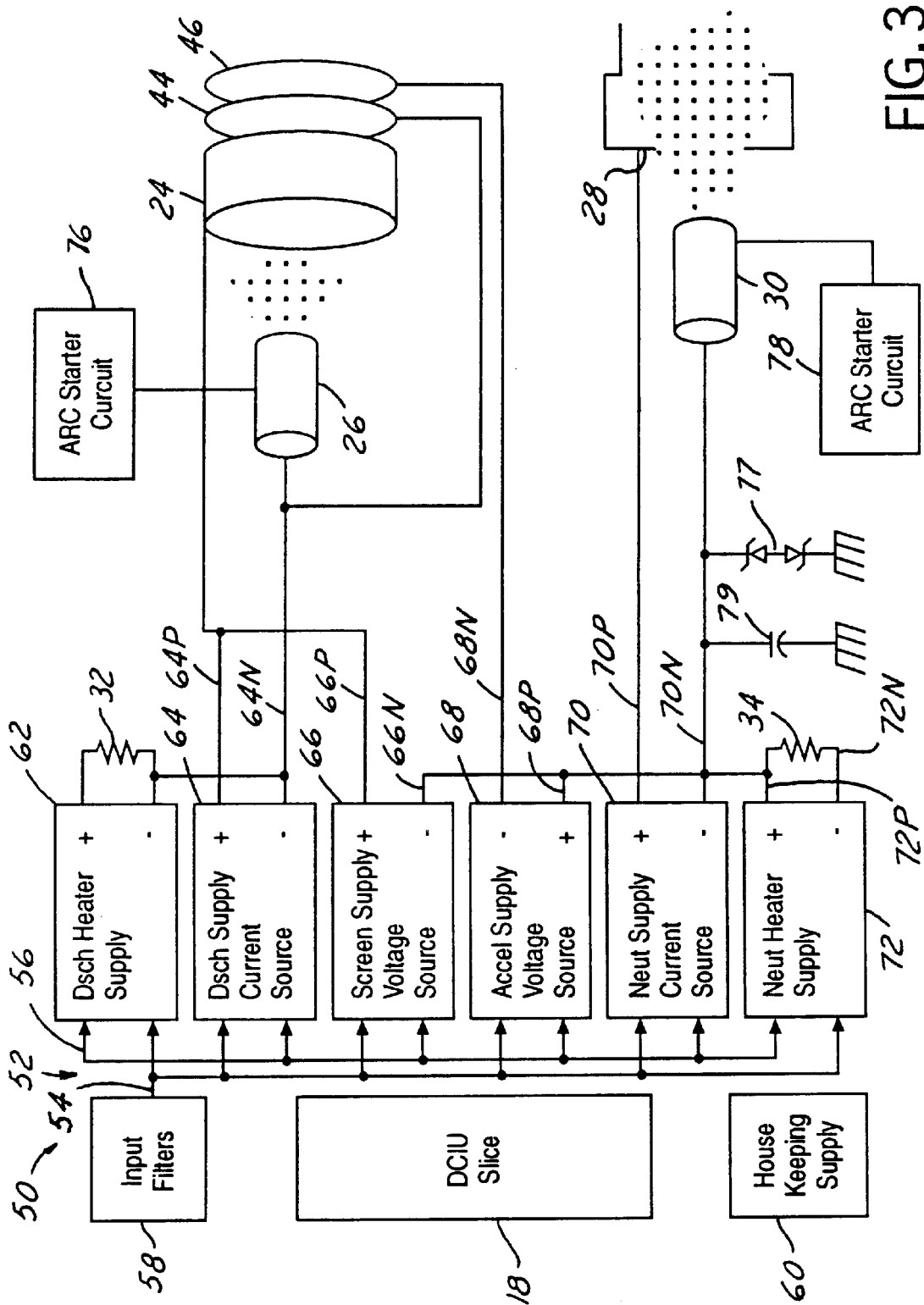

FIG. 3

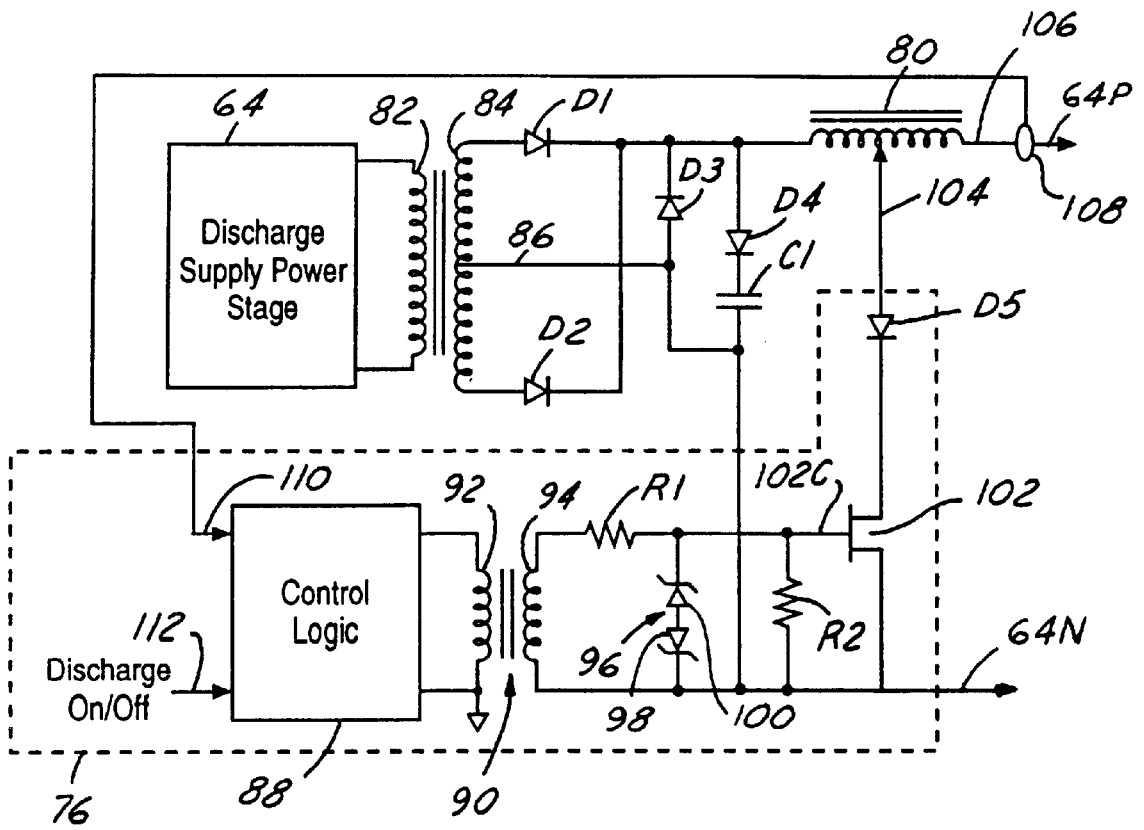

FIG. 4

STARTER CIRCUIT FOR AN ION ENGINE

“The invention described herein was made in the performance of work under NASA Contract Number NAS3-27560 and is subject to the provisions of Section 305 of the National Aeronautics and Space Act of 1958 (72 Stat. 435; 42U.S. C 2457).”

TECHNICAL FIELD

The present invention relates generally to an ion propulsion system, and in particular to a method and apparatus for igniting a plasma in an ion propulsion system.

BACKGROUND OF THE INVENTION

For over thirty years, ion engines have been proposed for propulsion of vehicles in space. Outside of space propulsion, ion generation may also be applied to various types of materials processing systems involving ion sources, such as for ion beam etching or micromachining. Ion engines use movement of ions to provide thrust.

Generally, an ion engine has an ion accelerator system that uses an anode, a cathode, a screen grid and an accelerator grid coupled within a thruster housing. Generally, an ion engine works by generating an inert gas plasma within the thruster housing. Xenon is an example of a suitable gas. A charge within the plasma between the anode and cathode forms ions. The inert gas ions leave the thruster through the charged screen and accelerator. The net force from the ions leaving the thruster housing generates a thrust. A neutralizer is located outside the thruster housing and generates electrons. The electrons are attracted to the ions so the ions do not re-enter the thruster housing as they otherwise would in space.

To initiate a breakdown of the xenon to form ions in the thruster or electrons at the neutralizer a high voltage breakdown must occur between the anode and cathode. Previously, it was thought that separate power supplies must be used to initiate the high voltage breakdown at both the thruster and the neutralizer.

In spacecraft design, it is desirable to eliminate parts and complexity when possible. More parts increases weight of the spacecraft. More parts and complexity inherently reduces reliability.

It is therefore an object of the invention to provide a power supply system that operates reliably and reduces overall weight and complexity.

SUMMARY OF THE INVENTION

It is therefore one object of the invention to provide a starter circuit that operates reliably and reduces overall weight of the spacecraft.

In one aspect of the invention, a starter circuit includes a power supply having an output inductor with a tap. A switch is coupled to the tap. The switch has a control input. A pulse control logic circuit is coupled to said control input, said pulse control logic circuit controlling said switch to an off state to generate a high voltage discharge.

In a further aspect of the invention, a method of starting plasma includes the steps of:

- emitting a gas;
- charging an inductor having a tap and an output;
- coupling a starter circuit to said tap;
- controlling the starter circuit to initiate a high voltage discharge;

producing a current through the gas;
 establishing a plasma; and
 igniting the plasma.

Another advantage of the invention is that because a pulse input is used rather than a continuous source a high voltage rectifier and regulation control circuit are not required.

One advantage of the invention is a separate power supply for the starter circuit has been eliminated from the spacecraft. This reduces weight and complexity.

Other features and advantages of the invention are readily apparent from the following detailed description of carrying out the invention when taken in connection with the accompanying drawings.

BRIEF DESCRIPTION OF THE DRAWINGS

FIG. 1 is a perspective view of a spacecraft having a power supply circuit according to the present invention.

FIG. 2 is a cross sectional view of an ion thruster having a power supply according to the present invention.

FIG. 3 is a block diagram of a power supply system according to the present invention.

FIG. 4 is a block diagram of a starter circuit.

DESCRIPTION OF THE PREFERRED EMBODIMENTS

In the following description, identical reference numerals are used to identify identical components in the various figures. The present invention is particularly suitable for use in a spacecraft. The power supply circuit of the present invention is also useful in other applications that have a wide dynamic range of system operability including a varying load or input. The present invention is also applicable to other systems that include ion sources such as materials processing equipment like ion beam etching or micromachining.

Referring now to FIG. 1, a spacecraft 10 has a thruster housing 12 that houses an ion thruster 14. Spacecraft 10 further includes solar panels 15 as a source of electrical power. In the present invention, spacecraft 10 is powered by xenon ions which are generated in ion thruster 14. Spacecraft 10 includes a xenon feed subsystem 16 supplying xenon to thruster 14. A digital interface and control unit (DCIU)18 is also coupled to the thruster housing 12.

A neutralizer 20 is also coupled to thruster housing 12 and xenon feed subsystem 16. As will be further described below, neutralizer 20 generates electrons to neutralize the positive ions emitted by thruster 14.

Thruster 14 generally includes an anode 24 and a cathode 26. Neutralizer 20 also includes an anode 28 and a cathode 30. Cathodes 26, 30 each have a respective heater 32, 34. Thruster 14 and neutralizer 20 also include a respective xenon source 36, 38 that are part of xenon feed subsystem 16. A keeper 40, 42 for concentrating the stream of xenon (ions or electrons) may also be provided near respective cathodes 26, 30.

Thruster 14 further includes a screen grid 44 and an accelerator grid 46. Both screen grid 44 and accelerator grid 46 are formed of an electrically conductive mesh material.

A plasma screen 48 may be used to enclose thruster 14 on sides other than where screen 44 and accelerator 46 are positioned. Plasma screen 48 is used to capture and prevent spalling of ion sputtered grid material.

A power supply circuit 50 is incorporated into spacecraft circuitry. Power supply circuitry 50 is coupled to anodes 24, 28, cathodes 26, 30, heaters 32, 34, screen grid 44 and accelerator 46.

At a high level of operation, xenon sources **36, 38** are used to generate a plasma of xenon adjacent to cathodes **26, 30**, respectively. Heaters **32, 34** are used to heat the xenon plasma upon start up. An arc starter circuit shown in FIG. **3** is used to ignite the xenon plasma. Thruster **14** uses the xenon ions for thrust. As the xenon ions pass through screen **44** and accelerator grid **46**, thrust is created. Neutralizer **20** generates a xenon plasma as well. However, the goal of neutralizer **20** is to generate electrons that are used to electrically balance the xenon positive ions in space to prevent the xenon ions from being attracted back to the spacecraft.

Referring now to FIG. **3**, power supply circuit **50** is illustrated in greater detail. A central spacecraft bus **52** couples the base components of power supply circuit **50** together. Spacecraft bus **52** includes a bus input **54** and a bus return **56**.

Input filters **58** may be coupled to spacecraft bus **52** to reduce electrical noise. Input filters **58** may take the form of capacitors or other circuit components as would be evident to those skilled in the art.

The control of the power supply circuit **50** is controlled by DCIU **18**. DCIU **18** is also coupled to bus **52**. A housekeeping supply **60** may also be incorporated into power supply circuit **50**. Housekeeping supply **60** may be used for other functions besides a centralized system and may not be coupled to bus **52**.

Power supply circuit **50** includes a plurality of application specific power supplies. The application specific power supplies are sized in terms of current and voltage based on the specific components to which they are connected. The specific power supplies may include a discharge heater supply **62**, discharge supply current source **64**, screen supply voltage source **66**, an accelerator supply voltage source **68**, a neutralizer supply current source **70**, and a neutralizer heater supply **72**. Discharge heater supply **62** is coupled to heater **32** and is disposed within thruster **14**. Discharge supply current source **64** has a positive output **64P** coupled to anode **24**. Discharge supply current source **64** also has a negative output coupled to cathode **26**. Negative output may also be coupled to screen grid **44**. Screen supply voltage source **66** has a positive output **66P** that may also be coupled to anode **24**. Accelerator supply voltage source **68** has a negative terminal coupled to accelerator **46**. Neutralizer supply current source **70** has a positive output **70P** coupled to neutralizer anode **28**. Neutralizer supply current source has a negative output **70N** coupled to neutralizer cathode **30**. A filter capacitor **79** and a voltage clamp **77** may be coupled to negative output **77** of neutralizer supply **70**. Neutralizer heater supply **72** is coupled to heater **34**. Neutralizer heater supply **72** has a positive output **70P** and a negative output **70N**.

A negative output **66N** of screen supply voltage source **66**, a positive output **68P** of accelerator supply voltage source **68**, a negative output **70N** of neutralizer supply current source **70** and negative output **72N** of neutralizer heater supply **72** may all be coupled together at the same electrical potential. Discharge arc starter circuit **76** and a neutralizer arc starter circuit **78** may be coupled to cathodes **26, 30** respectively. As described above, arc starter circuits **76, 78** are used to ignite the ion plasma.

Referring now to FIG. **4**, starter circuit **76** is illustrated in further detail. Starter circuit **76** is identical to neutralizer starter circuit **78** except that the feedback current threshold is adjusted downward as will be further described below.

Sufficient power to generate a high voltage pulse to initiate an arc is obtained from a power supply that is

currently used in the present invention. By using a power supply already available new components for providing power to starter circuit **76** are not required. Discharge power supply **64** is suitable because the circuitry includes a smoothing inductor **80** as part of the output of circuitry. Current is established between positive output **64P** and negative output **64N** of discharge power supply **64**. Discharge power supply **64** also has a primary winding **82** and a secondary winding **84**. Secondary winding is coupled to rectifier diodes **D1** and **D2**. Secondary winding **84** may also have a tap **86** extending therefrom. Tap **86** is coupled to the thruster cathode and inductor **80** through diode **D3** and through capacitor **C1** and diode **D4**.

Starter circuit **76** includes control logic **88** that controls the initiation of a high voltage. Control logic may comprise a plurality of logic circuits or may be microprocessor-based. Control logic is coupled to a transformer **90** having a primary winding **92** and a secondary winding **94**. Secondary winding is coupled to a resistor **R1** and a voltage clamp **96** that is comprised of a pair of zener diodes **98** and **100**. A second resistor **R2** is coupled in parallel with voltage clamp **96**.

Control logic **88** controls a switch **102**. Switch **102** has a control input **102C** that is coupled to control logic **88** through transformer **90**.

Switch **102** is coupled between a tap **104** on inductor **80** through an isolating diode **D5**. Inductor **80** has a discharge output **106**. Current at discharge output is monitored through a sensor **108**. Sensor **108** is coupled to control logic **88** through a feedback input **110**. Control logic **88** may also have a discharge on/off input **112**. Discharge on/off input **112** may be derived from other controllers within the spacecraft such as DCIU.

In operation, the starter circuit **96** generally operates as follows. When switch **102** is turned on, current increases in inductor **80** to store energy therein. When switch **102** is turned off rapidly, a high voltage spike is generated across inductor **80** which appears at discharge output **106**. Discharge output **106** may, for example, be coupled to the thruster anode **24** described above where the high voltage will generate ions which conduct discharge current to form the plasma.

To determine whether a high voltage discharge is to be applied to output **106**, control logic **88** monitors current at current sensor **108**. If the plasma is maintaining ion generation the current flowing between the cathode and anode is greater than 1.5 amps. In the present example, if the current monitor indicates less than 1.5 amps which is a level corresponding to no ion generation, the starter operation is initiated as described in the following: A pulse is released through transformer **90** to drive the switch **102**. Inductor **80** acts as an auto-transformer that boosts the voltage to about 200 volts for about 20 microseconds. When the arc is established between cathode **26** and anode **24**, current from discharge supply **64** maintains the plasma. When the discharge current exceeds 1.5 amps, control logic **88** inhibits further pulses and thus enters a standby mode to conserve energy. If the discharge current drops below 1.5 amps (indicating that the arc has been extinguished), control logic **88** pulses switch **102** to generate high voltage pulses at output **106**.

The same circuitry as starter circuit **76** may be used for neutralizer starter circuit **78**. However, the threshold to initiate a high discharge output by control logic **88** need only be 0.5 amps.

While the best mode for carrying out the present event has been described in detail, those familiar with the art to which

5

this invention relates will recognize various alternative designs and embodiments for practicing the invention as defined by the following claims:

What is claimed is:

1. A starter circuit comprising:
 - a power supply having an output inductor, said inductor having a tap;
 - a switch coupled to said tap having a control input; and
 - a pulse control logic circuit coupled to said control input, said pulse control logic circuit controlling said switch to an on state to store energy and then to an off state to generate a high voltage discharge.
2. A starter circuit as recited in claim 1 further comprising a current sensor coupled to said output inductor for sensing a current output of said inductor.

6

3. A starter circuit as recited in claim 1 further comprising a discharge current sensor, said current sensor coupled to said pulse control logic circuit.
4. A starter circuit as recited in claim 1 wherein said switch comprises a field effect transistor.
5. A starter circuit as recited in claim 1 wherein said pulse control logic comparing said current output to a current threshold and controlling said switch to an on and off state when said current output is below said threshold.
6. A starter circuit as recited in claim 5 wherein said current threshold is 1.5 amps.
7. A starter circuit as recited in claim 5 wherein said current threshold is 0.5 amps.

* * * * *