



US006157029A

United States Patent [19]
Chutjian et al.[11] **Patent Number:** **6,157,029**
[45] **Date of Patent:** **Dec. 5, 2000**[54] **MINIATURE MICROMACHINED
QUADRUPOLE MASS SPECTROMETER
ARRAY AND METHOD OF MAKING THE
SAME**[75] Inventors: **Ara Chutjian**, La Crescenta; **Michael Hecht**, Los Angeles; **Otto Orient**, Glendale; **Dean Wiberg**, La Crescenta; **Reid A. Brennen**, San Francisco, all of Calif.[73] Assignee: **California Institute of Technology**, Pasadena, Calif.[21] Appl. No.: **09/089,769**[22] Filed: **Jun. 3, 1998****Related U.S. Application Data**

[60] Provisional application No. 60/048,540, Jun. 3, 1997.

[51] **Int. Cl.**⁷ **H01J 49/42**[52] **U.S. Cl.** **250/292**[58] **Field of Search** 250/292, 281,
250/293, 291[56] **References Cited****U.S. PATENT DOCUMENTS**

5,248,883	9/1993	Brewer et al.	250/292
5,298,745	3/1994	Kernan et al.	250/292
5,386,115	1/1995	Freidhoff et al.	250/281
5,401,962	3/1995	Ferran	250/292
5,481,110	1/1996	Krishnaswamy et al.	250/288
5,492,867	2/1996	Kotvas et al.	437/228
5,530,244	6/1996	Sriram et al.	250/281

OTHER PUBLICATIONS

Boumsellek, S. et al., "Towards the Miniaturization of Mass, Velocity, and Energy Analyzers," Jet Propulsion Laboratory, California Institute of Technology, Jun. 1993.

Chutjian, Ara et al., "Miniature Arrays of Quadrupole and Ion Trap Mass Spectrometers," Abstracts, American Association for the Advancement of Science, 1995 AAAS Annual Meeting and Science Innovation Exposition, Atlanta, Georgia, Feb. 16-21, 1995, p. 55.

Introducing the Micropole Sensor For Affordable Gas Analysis, Brochure, Ferran Scientific, Oct. 1992.

"Miniature Quadrupole Mass Spectrometers," NASA Tech Briefs, Sep. 1996, pp. 74-75.

Primary Examiner—Kiet T. Nguyen*Attorney, Agent, or Firm*—Fish & Richardson P.C.[57] **ABSTRACT**

The present invention provides a quadrupole mass spectrometer and an ion filter for use in the quadrupole mass spectrometer. The ion filter includes a thin patterned layer including a two-dimensional array of poles forming one or more quadrupoles. The patterned layer design permits the use of very short poles and with a very dense spacing of the poles, so that the ion filter may be made very small. Also provided is a method for making the ion filter and the quadrupole mass spectrometer. The method involves forming the patterned layer of the ion filter in such a way that as the poles of the patterned layer are formed, they have the relative positioning and alignment for use in a final quadrupole mass spectrometer device.

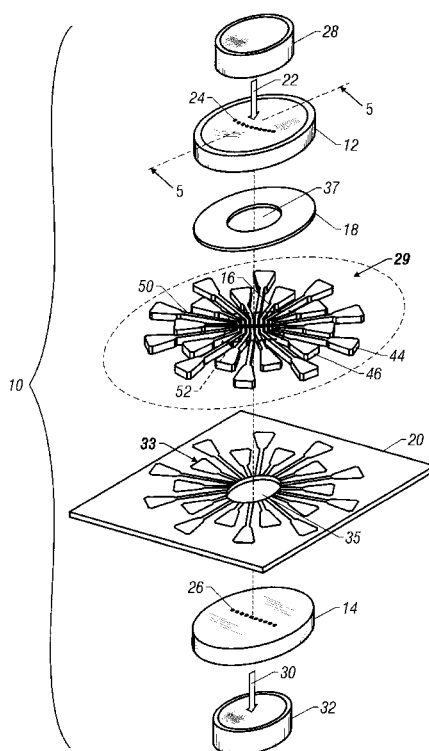
62 Claims, 5 Drawing Sheets

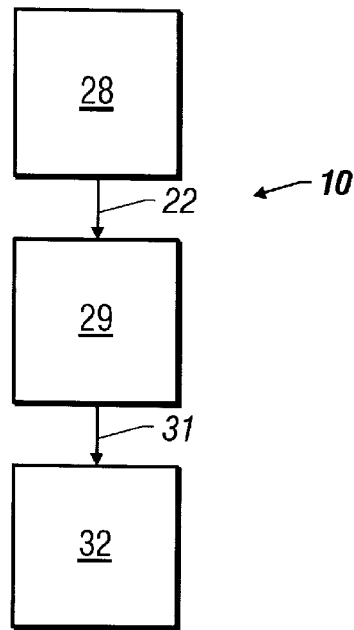

FIG. 1

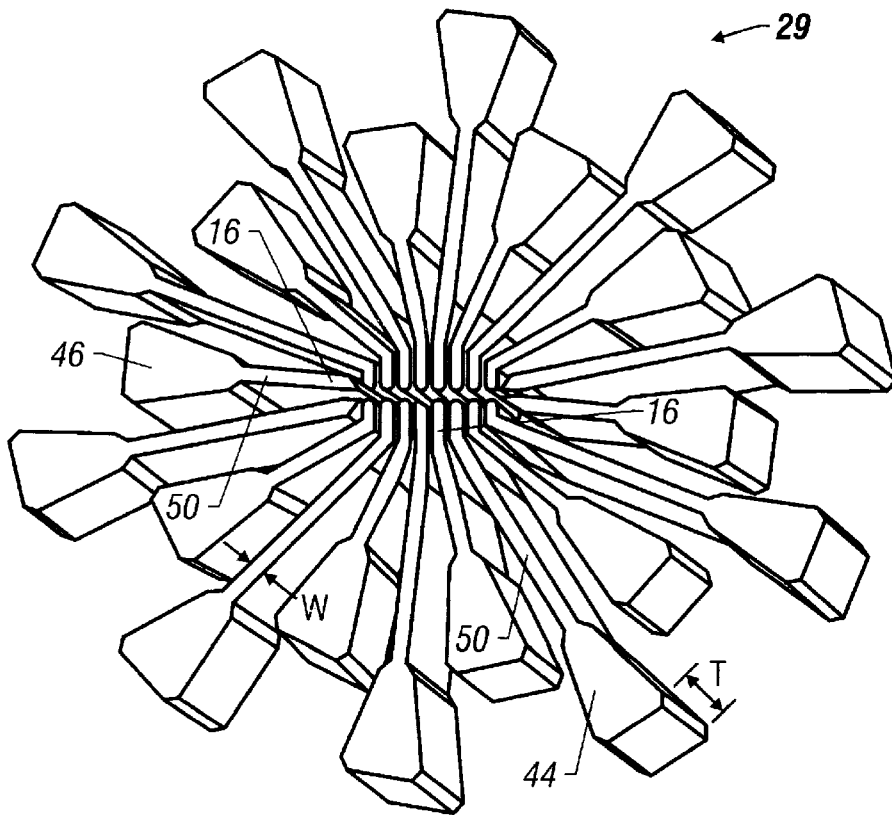

FIG. 3

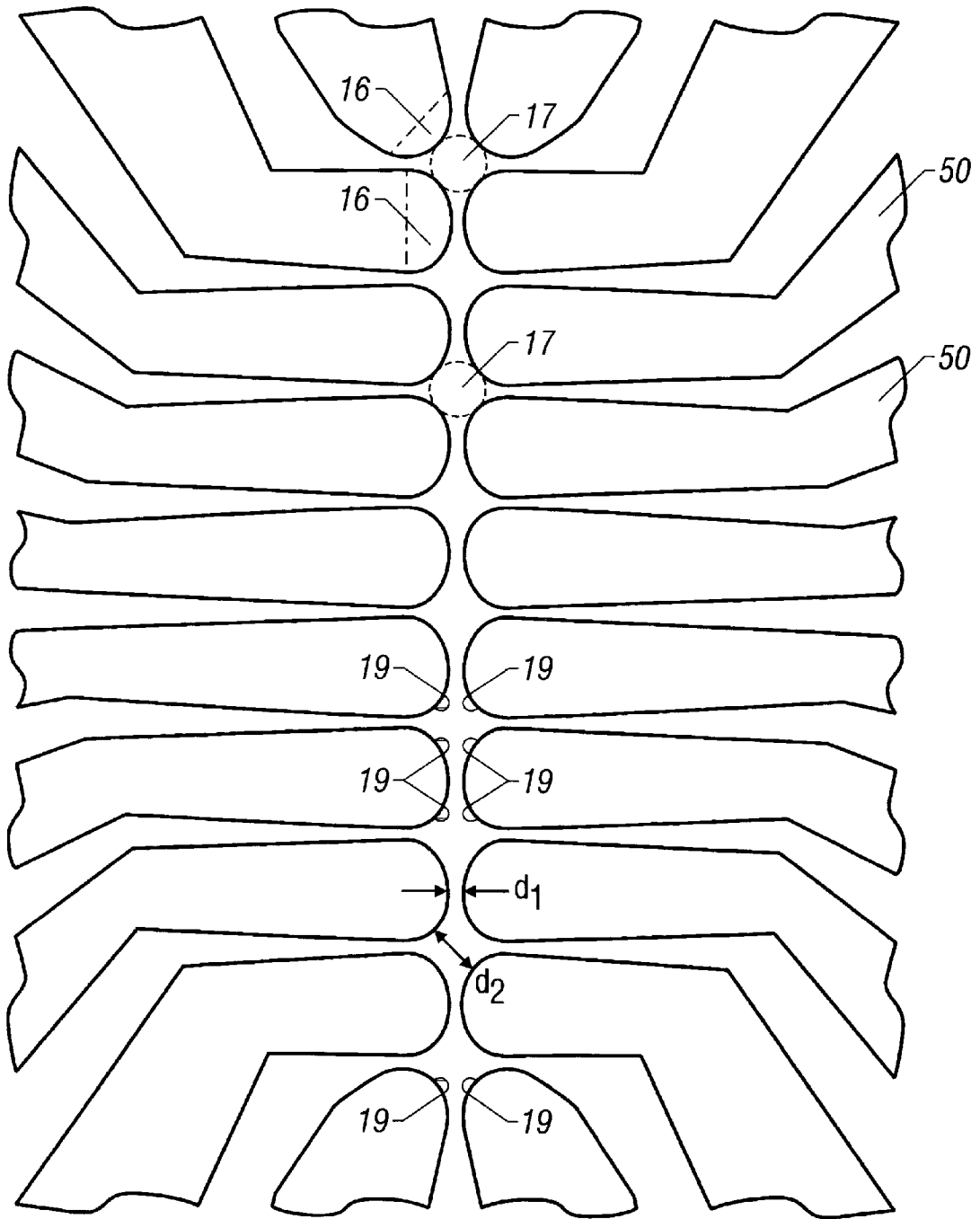

FIG. 2

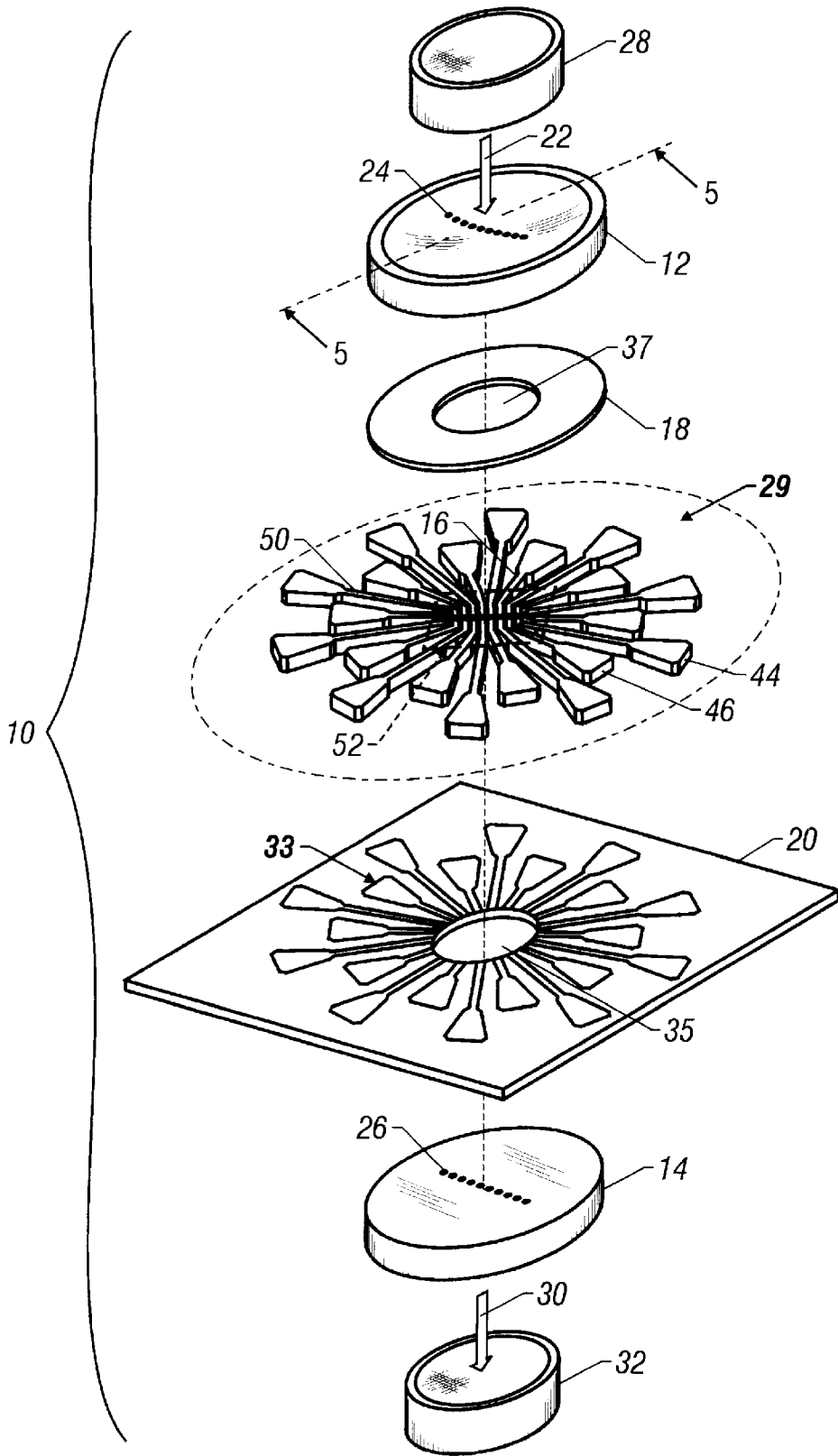

FIG. 4

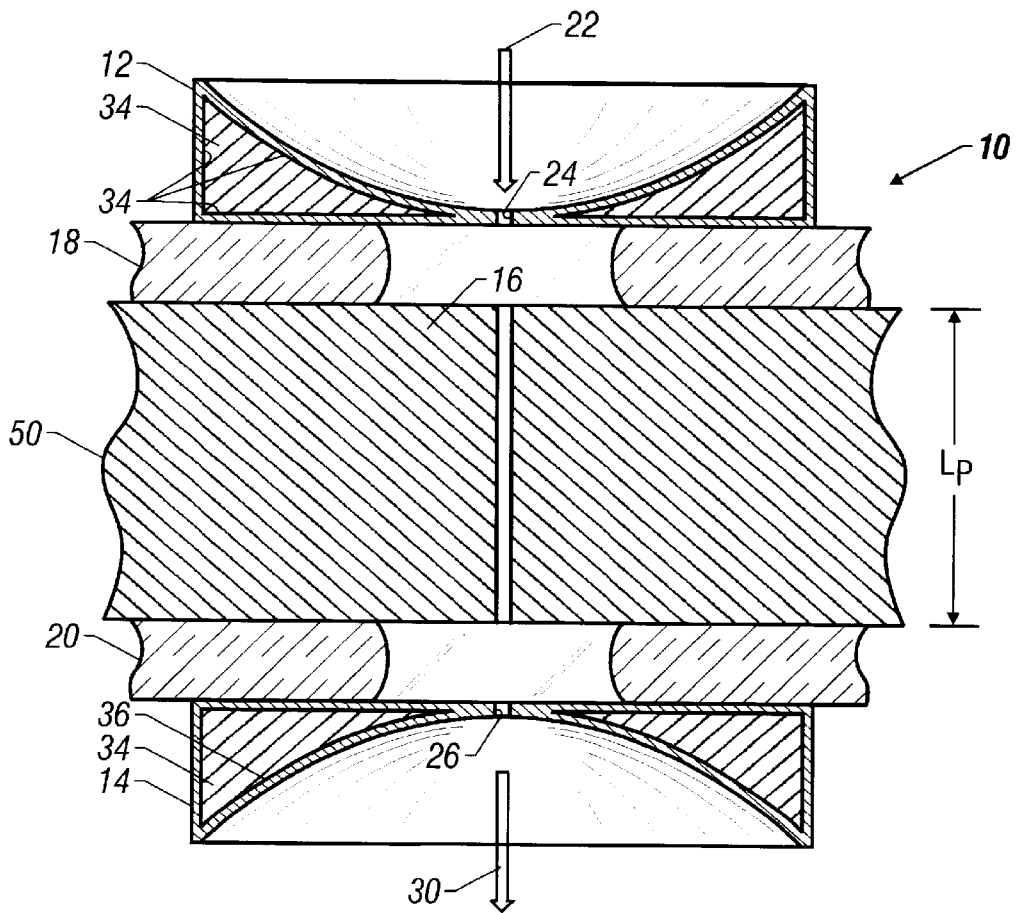

FIG. 5

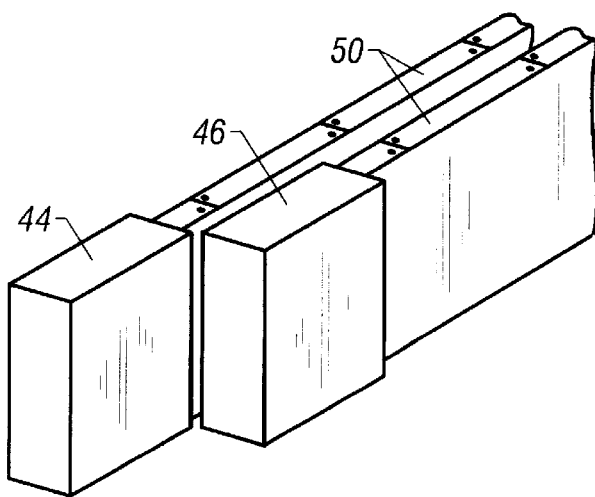

FIG. 6

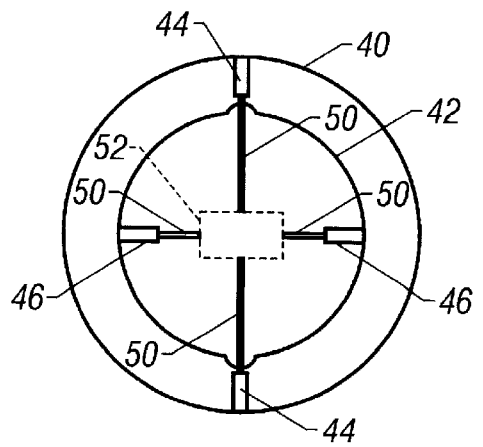

FIG. 7

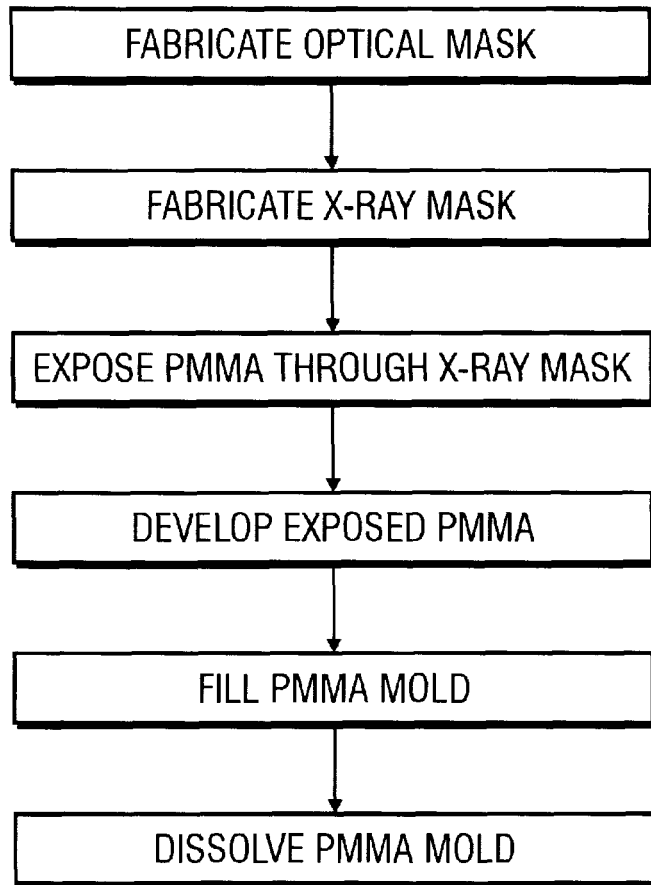

FIG. 8

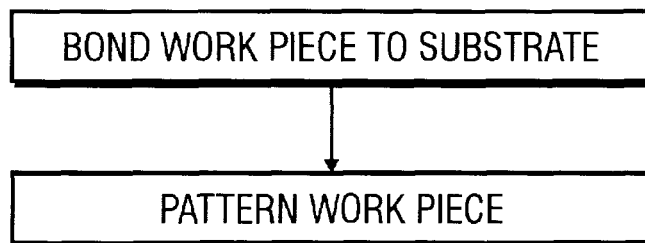

FIG. 9

**MINIATURE MICROMACHINED
QUADRUPOLE MASS SPECTROMETER
ARRAY AND METHOD OF MAKING THE
SAME**

**CROSS-REFERENCE TO RELATED
APPLICATIONS**

This application claims the benefit of priority under 35 U.S.C. §119 to U.S. Provisional Patent Application No. 60/048,540, filed Jun. 3, 1997. The entire contents of U.S. Provisional Patent Application No. 60/048,540 are incorporated herein, as if set forth herein in full.

**ACKNOWLEDGMENT OF GOVERNMENT
SUPPORT**

The invention described herein was made in the performance of work under a NASA contract and is subject to the provisions of Public Law 96-517 (35 U.S.C. 202) in which the Contractor has elected to retain title.

FIELD OF THE INVENTION

The present invention generally relates to quadrupole mass spectrometers. In particular, the present invention relates to a miniature micromachined ion filter for use in a quadrupole mass spectrometer, a quadrupole mass spectrometer including the ion filter, and methods of making the ion filter and the quadrupole mass spectrometer.

BACKGROUND OF THE INVENTION

Mass spectrometers are workhorse instruments finding applications in many commercial and military markets, with potential for use in domestic markets as well. A mass spectrometer is able to sample, in situ, the atmosphere in which it is placed and provide a reading of the atomic and molecular species (and any positive or negative ions) present in that atmosphere and of the absolute abundance of these species.

There are many types of mass spectrometers, such as magnetic sector, Paul or Penning ion trap, trochoidal monochromator, and the like. One popular type of mass spectrometer is the quadrupole mass spectrometer (QMS), first proposed by W. Paul (1958). In general, the QMS separates ions with different masses by applying a direct current voltage and a radio frequency ("rf") voltage on four rods having hyperbolic or circular cross sections and an axis equidistant from each rod. Opposite rods have identical potentials. The electric potential in the quadrupole is a quadratic function of the coordinates.

Ions are introduced in a longitudinal direction through a circular entrance aperture located at the ends of the rods and centered on the midpoints between rods. Ions are deflected by the field depending on their atomic mass-to-charge (m/z) ratio. By selecting the applied voltage amplitude and frequency of the rf signal, only ions of a selected m/z ratio exit the QMS along the axis of a quadrupole at the opposite end and are detected. Ions having other m/z ratios either impact the rods and are neutralized or deflect away from the centerline axis of the quadrupoles.

As explained in Bounsellek, et al. (1993), a solution of Mathieu's differential equations of motion in the case of round rods provides that to select ions with a m/z ratio using an rf signal of frequency f and rods separated by a contained circle of radius distance R_0 the peak rf voltage V_0 and dc voltage U_0 should be as follows:

$$V_0 = 7.233mf^2R_0^2$$

$$U_0 = 1.213mf^2R_0^2$$

Conventional QMS's weigh several kilograms, have volumes of the order of 10^4 cm³, and require 50–100 watts of power. Further, these devices usually operate at vacua in the range of 10^{-6} – 10^{-8} torr in order that the mean free path be comparable to the instrument dimensions, and where secondary ion-molecule collisions cannot occur. Commercial QMS's of this design have been used for characterizing trace components in the atmosphere (environmental monitoring), automobile exhausts, chemical-vapor deposition, plasma processing, and explosives/controlled-substances detection (forensic applications). However, such conventional QMS's are not suitable for spacecraft life-support systems and certain national defense missions where they have the disadvantages of relatively large mass, volume, and power requirements. A small, low-power QMS would find a myriad of applications in factory air-quality monitoring, pollution detection in homes and cars, protection of military sites, and protection of public buildings and transportation systems (e.g., airports, subways, and harbors) against terrorist activities.

One type of miniature QMS (U.S. Pat. No. 5,401,962) was developed by Ferran Scientific, Inc., San Diego, Calif. and includes a miniature array of sixteen rods comprising nine individual quadrupoles. The rods are supported only at the detector end of the QMS by means of powdered glass that is heated and cooled to form a solid support structure. The electric potential and rf voltage are applied by the use of springs contacting the rods. The Ferran QMS dimensions are approximately 2 cm diameter by 5 cm long, including a gas ionizer and detector, and has an estimated mass of 50 grams. The reduced size of the Ferran QMS results in several advantages over existing QMS's, including a reduced power consumption and a higher operating pressure.

The Ferran QMS has a resolution of approximately 1.5 amu in the mass range 1–95 amu. This is a relatively low resolution for a QMS, making the miniature Ferran QMS useful for commercial processing (e.g., chemical-vapor deposition, blood plasma monitoring) but not for applications that require accurate mass separation, such as in analytical chemistry and in spacecraft life-support systems. Bounsellek et al. (1993) traced the low resolution to the fact that the rods were aligned only to within a $\pm 3\%$ accuracy, whereas an alignment accuracy in the range of $\pm 0.1\%$ is necessary for a high resolution QMS.

A separate miniature QMS (U.S. Pat. Nos. 5,596,193 and 5,719,393) was developed by the Jet Propulsion Laboratory (JPL), California Institute of Technology to address the continuing need for a reduced size QMS having an acceptable rod alignment. The JPL QMS provides improved resolution over the Ferran QMS due to improved accuracy in rod alignment. As may be appreciated, the accurate positioning and alignment of individual miniature rods in an array significantly increases the cost of manufacturing due to the increased time and specialized equipment required for precisely aligning separate miniature rods. As the size of the rods is further reduced, the complexity, difficulty and expense of rod positioning and alignment increases. In this regard, there is a need for a small QMS having high resolution that may be made by simpler and less expensive manufacturing process.

SUMMARY OF THE INVENTION

In one aspect, the present invention provides a quadrupole ion filter, and a quadrupole mass spectrometer including the ion filter, that avoids problems associated with miniaturiza-

tion of conventional quadrupole mass spectrometer devices, and especially problems concerning the incorporation of loose rods into conventional devices. The ion filter includes a patterned layer of electrically conductive material, with the patterned layer including a two-dimensional array of poles for one or more quadrupoles. The array of poles in the pattern is two dimensional in that the poles in the array have a regular spacing in the x-y plane, with the length of the poles in the array being in the z direction. The poles of the ion filter serve the same function as the rods in conventional quadrupole devices. The patterned layer is divided into a number of separate sections, or pieces, each including at one terminal end one pole in the array of poles. At the other terminal end of each separate piece is a bonding location for convenient electrical connection of the piece with an external power source.

Structurally, the quadrupole ion filter of the present invention is considerably different than the quadrupole structure in conventional quadrupole mass spectrometers. Conventional quadrupole mass spectrometers, even those that have been miniaturized, use poles that are in the form of individual longitudinally extending rods. The ion filter of the present invention, however, includes the array of poles in a thin patterned layer, with the thickness of the layer corresponding with the length of the poles.

The patterned layer in the ion filter of the present invention typically has a thickness of smaller than about 6 millimeters, although even smaller thicknesses may be preferred for some applications. In that regard, the thinner that the patterned layer is, the shorter the length of poles and, therefore, the shorter the distance that ions must travel to pass through the ion filter. A shorter length of travel through the ion filter permits operation at higher pressures, which is a significant advantage with the ion filter of the present invention.

By use of the patterned layer in the ion filter of the present invention, it is possible to make the poles of an extremely small size and with an extremely dense spacing. For example, with the present invention, the density of poles in the patterned layer is typically greater than about 2 poles per square millimeter, and in many embodiments the density is much higher. Furthermore, directly opposing poles in the patterned layer are typically separated by a distance of shorter than about 0.2 millimeter, and in many embodiments by an even shorter distance. Diagonally opposing poles in the patterned layer are typically separated by a distance of shorter than about 0.3 millimeter, and in many embodiments by an even shorter distance. Because of the extremely small size and dense spacing of the poles, the ion filter may include a large array of poles in a small space, with different groupings of four adjacent poles each defining a channel for passage of ions. With the present invention, however, these quadrupole channels are extremely small. When the ion filter includes a large array of poles, defining a plurality of quadrupole channels, the channels are typically present in a density of larger than about one of the quadrupole channels per square millimeter, and often greater than two of the quadrupole channels per square millimeter.

An advantageous structure for the ion filter of the present invention is one in which substantially all of the patterned layer is supported by a single, common supporting substrate, which is typically of dielectric material. The patterned layer is such, however, that a portion of the patterned layer that includes the poles is suspended from the substrate. Typically, the suspended portion of the patterned layer extends over an opening that passes through the substrate. In this way, the opening provides a passageway to permit ions access to the

quadrupole channels. The patterned layer is bonded to the supporting substrate in a manner that maintains positioning and alignment of the poles, even though the poles are suspended from the substrate.

A significant aspect of the present invention is manufacture of the quadrupole ion filter, and manufacture of quadrupole mass spectrometers including the ion filter. According to the present invention, a method is provided in which the poles in the patterned layer are made in a manner such that as the poles are made they have relative positioning and alignment for final use in a quadrupole mass spectrometer. This is typically accomplished, according to the method of the present invention, by forming the patterned layer of the ion filter on a common supporting substrate so that the patterned layer, as formed on the common supporting substrate, is bound to the substrate, such that the relative positioning and alignment of poles in the patterned layer is thereby fixed.

One preferred embodiment of the method for manufacturing the ion filter involves simultaneous manufacture of the patterned layer, including the poles, by filling a mold with electrically conductive material. The mold includes a template for the patterned layer. The mold is filled when it is situated on the surface of the common supporting substrate. When the mold is then removed, the patterned layer remains supported by the common supporting substrate. In one embodiment, the mold may be made by a technique known as Lithographic-Galvanoformung-Abformung (LIGA) manufacture.

Another embodiment of the method for manufacturing the present invention involves forming the patterned layer from a single work piece, typically in the form of a metallic sheet, that has been bonded to the common supporting substrate. Material is selectively removed from the work piece to form the patterned layer, such that the patterned layer, as formed, is bound to and supported by the common supporting substrate. Typically, the selective removal of material from the work piece is accomplished by electrical discharge machining (EDM).

The present invention also involves a quadrupole mass spectrometer including the mass filter of the present invention. The quadrupole mass spectrometer includes the ion filter located between an ion source and an ion detector. During operation, the ion source supplies ions to be filtered by the ion filter. Ions passing through the ion filter may then be detected by the ion detector. The quadrupole mass spectrometer may include spacers before and/or after the ion filter to maintain a predetermined spacing between the ion filter and the ion source and/or the ion detector and to assist in isolating the operation of the ion filter from influences from other components. These spacers are typically made of dielectric material. The quadrupole mass spectrometer may also include entrance and/or exit devices for enhancing performance of the quadrupole mass spectrometer. The entrance device is located between the ion source and the ion filter and typically includes a body of dielectric material having apertures therethrough for channeling ions from the ion source into the ion filter. In a preferred embodiment, the entrance device includes an electrically conductive metallic film at least on a side facing the ion source, to dissipate the charge of ions striking the entrance device. The exit device similarly includes a body of dielectric material having apertures therethrough for channeling ions exiting the mass filter to the ion detector. In a preferred embodiment, the exit device includes an electrically conductive metallic film on at least a side facing the ion filter, to dissipate the charge of ions striking the exit device.

Furthermore, the quadrupole mass spectrometer has a versatile design that may be adapted to a variety of situations. For example, a Faraday-type ion detector may be used for operation at relatively high pressures, often in the millitorr range. For operation of the device at very low pressures, such as those below about 10^{-4} torr, a single particle multiplier may be used as the ion detector.

Also, according to the present invention, the quadrupole mass spectrometer including the ion filter may easily be manufactured through proper alignment and assemblage of the individual components.

BRIEF DESCRIPTION OF THE DRAWINGS

FIG. 1 is a block diagram showing major components of one embodiment of a quadrupole mass spectrometer of the present invention;

FIG. 2 is a partial top view, drawn to a large scale, of one embodiment of an array of poles in an ion filter of the present invention.

FIG. 3 is a perspective view of one embodiment of an ion filter of the present invention;

FIG. 4 is an exploded view in perspective illustrating several of the components and their arrangement in one embodiment of a quadrupole mass spectrometer of the present invention;

FIG. 5 is a partial cross section through a single pair of metallic poles of one embodiment of a quadrupole mass spectrometer array of the present invention;

FIG. 6 is a partial perspective view of a bonding pad configuration with connecting strips attached to alternate poles of one embodiment of a quadrupole mass spectrometer of the present invention;

FIG. 7 is a top view of one embodiment of a bonding configuration for making electrical connection to poles of an ion filter of the present invention;

FIG. 8 is a flow diagram illustrating one embodiment of a LIGA-based process of the present invention for making an ion filter for use in a quadrupole mass spectrometer;

FIG. 9 is a flow diagram illustrating one embodiment of an EDM-based process of the present invention for making an ion filter for use in a quadrupole mass spectrometer.

DETAILED DESCRIPTION

The present invention provides a quadrupole mass spectrometer comprising an ion source, an ion filter, and an ion detector, useful for in situ sampling of an atmosphere for identification of atomic and molecular species that may be present in the atmosphere. The present invention also includes an ion filter for use in the quadrupole mass spectrometer including an array of at least 4 miniature poles defining at least one quadrupole channel through which ions pass for detection. The array of poles is typically used to perform the ion filtering function in the mass filter component of the quadrupole mass spectrometer. The ion filter typically comprises a sufficiently large two-dimensional array of poles to define a plurality of quadrupole channels in a quadrupole mass spectrometer array (QMSA). Having a plurality of quadrupole channels is advantageous to enhance detection sensitivity, especially for the miniature device of the present invention because the detection sensitivity associated with a quadrupole channel generally decreases with decreasing channel size, due to the smaller cross-sectional area of the channel that is available for passage of ions.

Referring now to FIG. 1 the major components of the quadrupole mass spectrometer of the present invention are

shown. As illustrated in FIG. 1, a miniature micromachined quadrupole mass spectrometer 10 is shown including an ion source 28, an ion filter 29, and an ion detector 32. The mass spectrometer 10 operates according to known principles. During operation, the ion source 28 provides ions in an ion beam 22. Ions in the ion beam 22 travel to the ion filter 29 where ions are filtered according to the m/z ratio of the ions, with m referring to the mass of an ion and z referring to the charge of an ion. Mass filtered ions 31 exiting the ion filter 29 may then be detected by the ion detector 32. At any given time, the mass filtered ions 31 include substantially only ions in a narrow range of m/z ratios, so that the ion detector 32, at any given time, is detecting only ions within the narrow range. The location of the m/z range of the mass filtered ions 31 may be periodically or continuously varied by varying rf frequency and voltages to the ion filter 29, as discussed further below, using control electronics known in the art. In this way, the mass spectrometer may be used to detect ions over a wide range of m/z values. Information from the ion detector 32 concerning detected ions may be interpreted by techniques known in the art for identification of atomic and molecular species originally present in the atmosphere being sampled by the mass spectrometer 10.

The ion source 28 may be any apparatus capable of generating ions for filtering in the ion filter 29. Examples of the ion source 28 include a field-emission ionizer and an electron-impact ionizer. Preferred as the ion source 28 is an electron-impact ionizer.

The ion detector may be any apparatus capable of detecting the mass filtered ions 31. Examples of the ion detector 32 include a Faraday-type ion detector, a single-particle multiplier and a flat micromachined plate. Preferred as the ion detector 32 is a miniature micromachined-plate ion multiplier.

The ion filter 29 includes the QMSA of the present invention as an active element for filtering ions for detection. The QMSA filters ions based on general principles well known in the operation of quadrupole mass spectrometers. The QMSA of the present invention, however, can be of an extremely small size, which is advantageous for many uses, especially when size or weight considerations are important, such as in space applications. Also, the QMSA of the present invention is manufacturable by micromachining techniques that lend themselves to relatively high volume, low cost manufacture.

One embodiment of the QMSA of the present invention is shown in FIG. 2, including an array of poles 16, with any grouping of four adjacent poles 16 defining a quadrupole channel 17 through which ions travel during use. The quadrupole channel 17 refers to the space defined by any grouping of four poles 16 within areal boundaries defined by a circle that is substantially tangent to each of the four relevant poles 16, as exemplified by the dotted circles shown for two of the quadrupole channels 17 in FIG. 2. Each of the poles 16 form an integral structure with a connecting strip 50, which acts as an electrical lead to the respective one of the poles 16. Each of the poles 16, therefore, forms the terminal portion of an integral piece including one of the poles 16 and a corresponding connecting strip 50.

With continued reference to FIG. 2, each of the poles 16 has either one or two curved exterior surfaces 19, such that each of the quadrupole channels 17 has four of the curved surfaces 19 facing the quadrupole channel 17. The curved surfaces 19 as shown in FIG. 2 have a hyperbolic shape, which is preferred for the poles 16. Other surface shapes, could, however, be used, such as an arc of a circle.

In a conventional quadrupole mass spectrometer, the poles would be separate pieces, such as individual circular rods, assembled in an array. With reference to FIG. 2, the poles 16 of the QMSA of the present invention are significantly different than the poles in conventional quadrupole mass spectrometers, because the poles 16 are a terminal portion of a larger integral structure, as noted above. The terminal portions forming the poles 16 of the present invention generally include only the terminal portions of the integral structure generally within the area defined by the curved surfaces 19, as shown by the dotted lines shown for two of the poles 16 in FIG. 2. One significant advantage of the poles 16 of the present invention is their small size. Typically, the cross sectional area of the poles 16 (i.e., the terminal area inside of the dotted lines shown in FIG. 2) is smaller than about 0.3 square millimeter, preferably smaller than about 0.2 square millimeter and more preferably smaller than about 0.1 square millimeter.

A significant advantage of the QMSA of the present invention is the extremely small size and dense spacing of the poles 16 forming the array. With continued reference to FIG. 2, in a preferred embodiment, the face-to-face spacing (d1) between adjacent, directly opposing poles 16 is smaller than about 0.2 millimeter, preferably smaller than about 0.15 millimeter, and most preferably smaller than about 0.1 millimeter. Spacing (d2) between diagonally opposing poles 16 is preferably smaller than about 0.3 millimeter, more preferably smaller than about 0.25 millimeter, still more preferably smaller than about 0.2 millimeter and most preferably smaller than about 0.15 millimeter. According to the present invention, the density of quadrupoles in the QMSA is typically greater than about 2 quadrupoles per square millimeter, preferably greater than about 3 quadrupoles per square millimeter, more preferably greater than about 4 quadrupoles per square millimeter, and most preferably greater than about 5 quadrupoles per square millimeter, with the area measured in a plane perpendicular to the longitudinal axes of the quadrupoles in the array. As used herein, a quadrupole refers to the equipotential area, when the device is operating, in the area of a quadrupole channel 17 defined by any grouping of four adjacent of the poles 16 of the array. With such a high density of quadrupoles per cross-sectional area, the QMSA can easily accommodate 10 quadrupoles in devices designed for applications having even the tightest space requirements, and more preferably at least 100 quadrupoles. The density of poles 16 in the array is preferably greater than about 2 poles per square millimeter, more preferably greater than 4 poles 16 per square millimeter, still more preferably greater than about 6 poles 16 per square millimeter, and most preferably greater than about 8 poles 16 per square millimeter. Particularly preferred is a pole density in the array of greater than about 10 poles 16 per square millimeter. With the dense spacing of the adjacently located poles 16 and, thus, dense spacing of quadrupoles, the spacing density of the quadrupole channels 17 is typically one or more of the quadrupole channels 17 per square millimeter, and preferably more than about two of the quadrupole channels 17 per square millimeter. When the array of the poles 16 defines more than one quadrupole and, consequently more than one of the quadrupole channels 17, the number of poles 16 will be at least 6, and preferably at least 20 and more preferably at least 100. Furthermore, the area of each of the quadrupole channels 17 for accepting ions (i.e., the area of the exemplified inscribed circles in FIG. 2) is very small, typically smaller than about 0.05 square millimeter, preferably smaller than about 0.03 square millimeter and more preferably smaller than about 0.02 square millimeter.

The poles 16 of the array are positioned between the ion source 28 and the ion detector 32 of the quadrupole mass spectrometer such that substantially the entire length of each pole 16 is within the space between the ion source and the ion detector. The poles 16 preferably have a length of shorter than about 6 millimeters, more preferably a length of shorter than about 4 millimeters, even more preferably a length of shorter than about 3 millimeters. In one embodiment, the length of the poles 16 is shorter than about 2 millimeters.

The QMSA is part of the ion filter 29 of the present invention. One embodiment of the ion filter 29 is shown in FIG. 3. The ion filter 29 includes a thin patterned layer of electrically conductive material, preferably of an electrically conductive metal such as gold or titanium. The patterned layer includes a plurality of elongated electrically conducting portions, each including in a single integral piece a pole 16, a bonding pad 44 or 46, and a connecting strip 50, with the connecting strip 50 being located intermediate between the pole 16 and the bonding pad 44 or 46.

The pole 16 is located at one terminal end of each integral piece, as previously described with reference to FIG. 2, and the bonding pad 44 or 46 is located at the opposite terminal end. The bonding pad 44 or 46 provides a location for making an electrical connection to an external power source for providing power to the array of the poles 16, and the connecting strip 50 provides an electrical lead from the bonding pad 44 or 46 to the pole 16. As shown, the bonding pad 44 or 46 has a greater width than the pole 16 or the connecting strip 50. Although not necessary to the present invention, having a wider area available for bonding is preferred for ease of making an electrical connection. Preferably, the bonding pad 44 or 46 is suitable for making a wire bond connection to an external power source.

Preferably, each of the integral pieces has a substantially constant layer thickness (shown as dimension T in FIG. 3) for all of the bonding pad 44 or 46, connecting strip 50 and pole 16. Furthermore, it is preferred that all of the integral pieces making up the patterned layer are of substantially the same thickness. A substantially constant thickness for the patterned layer facilitates ease of manufacture of the ion filter 29 and incorporation of the ion filter 29 into a quadrupole mass spectrometer. The thickness of the patterned layer is preferably substantially equal to the length of the poles 16. The connecting strips 50 preferably have a width (shown as dimension W in FIG. 3) of smaller than about 0.5 millimeter.

The patterned layer of the ion filter 29 is typically substantially all supported by a common substrate. This is important both from a manufacturing perspective, as discussed below, and from an operational perspective, due to the narrow tolerances achievable when the integral pieces for all of the poles 16 are supported by a common substrate. The common substrate is typically of a dielectric material. Examples of such dielectric materials include alumina and glass. Furthermore, the common substrate will typically include an opening over which the poles 16 and a portion of the connecting strips 50 are suspended. The opening forms part of a pathway for ions traveling through the device, as described more fully below. The ion filter 29 may be supported on either side of the common substrate, the side facing the ion source 28 or the side facing the ion detector 32.

The ion filter 29 of the present invention may be incorporated into a quadrupole mass spectrometer in any convenient way. One preferred configuration is shown in FIG. 4, which is an exploded perspective view showing components

of one embodiment of a miniature micromachined quadrupole mass spectrometer **10**. As shown in FIG. 4, the quadrupole mass spectrometer **10** includes the ion source **28**, the ion filter **29** and the ion detector **32**. The mass spectrometer **10** also includes an entrance device **12**, such as an entrance plate, for controlling the movement of ions in the ion beam **22** into the ion filter **29** and an exit device **14**, such as an exit plate, for controlling the movement of the mass filtered ions **30** from the ion filter **29**. The mass spectrometer **10** also includes an entrance spacer **18**, and an exit spacer **20**. During operation of the mass spectrometer **10**, the entrance device **12** receives ions in the ion beam **22** from the ion source **28**. Ions in the ion beam **22** pass through entrance apertures **24** extending through the entrance device **12** to channel ions into quadrupole channels **17** (as shown in FIG. 2) within the array of electrically conductive poles **16**. The exit device **14** is located at a distal end from the entrance device **12** and provides ions with egress through exit apertures **26** extending through the exit device **14**. The mass-filtered ions **30** pass to the ion detector **32** for detection.

The array of poles **16** of the ion filter **29** is located adjacent to and between the entrance device **12** and the exit device **14**. The entrance spacer **18** maintains a predetermined spacing between the array of poles **16** and the entrance device **12**. The exit spacer **20** maintains a predetermined spacing between the array of poles **16** and the exit device **14**. The exit spacer **20** also acts as a common supporting substrate for the patterned layer of the ion filter **29**. One or both of the spacers **18**, **20** may be bonded to the structure of the ion filter **29** and to the entrance and exit devices **12**, **14**, respectively. As may be appreciated, many bonding methods, preferably non-contaminating bonding methods, such as diffusion- and anodic-bonding techniques, may be employed to obtain good bonding results. The spacers **18**, **20** may have any convenient thickness, but typically each have a thickness of smaller than about 1 millimeter and preferably smaller than about 0.5 millimeter.

Referring now to FIG. 5, a partial cross-section is shown through a single opposing pair of the metallic poles **16** for the mass spectrometer **10**, except that the ion source **28** and the ion detector **32** are not shown. As with the other figures, the cross-section of FIG. 5 is not necessarily to scale and is shown only for purposes of illustration. Shown in FIG. 5 are the entrance device **12**, including one of the apertures **24**, the exit device **14**, including one of the apertures **26**, two directly opposing poles **16**, the entrance spacer **18**, and the exit spacer **20**. Low dielectric-constant materials are preferably used for the spacers **18**, **20** to lower capacitance.

With reference to FIGS. 4 and 5, the poles **16** are preferably non-magnetic, non-reactive, metallic rods, such as gold or titanium. The spacers **18**, **20** are insulators, preferably of glass, to isolate the poles **16** during operation of the quadrupole mass spectrometer **10** of the present invention.

The entrance device **12** is important to at least partially isolate the ion filter **29** and the ion source **28** and to channel ions from the ion source into the ion filter **29**. By acting as an isolation shield, the entrance device **12** reduces the possibility of detrimental interference between the ion source **28** and the ion filter **29**.

The exit device **14** is important to at least partially isolate the ion filter **29** and the ion detector **32** and to channel ions from the ion filter **29** to the ion detector **32**. By acting as an isolation shield, the exit device **14** reduces the possibility of detrimental interference between the ion filter **29** and the ion detector **32**.

The entrance and exit devices **12**, **14** may each be comprised of substantially entirely only dielectric material. As shown in FIG. 5, however, it is preferred that the entrance device **12** and exit device **14** each include a dielectric interior body portion **34**, such as a silicon substrate **34**, coated with an electrically conductive outer layer **36**, preferably a gold/chromium film layer attached to and supported by the body portion **34**. Preferably, the electrically conductive outer layer **36** extends into the interior of the apertures **24**, **26**, as shown in FIG. 5. The electrically conductive outer layer **36** at least partially protects the array of poles **16** during operation of the quadrupole mass spectrometer **10** by dissipating the charge of ions that strike the outer layer **36**. The entrance device **12** may have a flat or concave surface for receiving the ion beam **22**, and the exit device **14** may have a flat or concave surface for directing the exiting mass-filtered ions **30**. As shown in FIGS. 4 and 5, the surfaces are concave. Furthermore, although it is most preferred that the electrically conductive outer layers **36** completely surround the entrance device **12** and exit device **14**, as shown in FIG. 5, such complete surrounding is not required. Preferably, however, the conductive outer layer **36** of the entrance device **12** covers at least a portion of, and more preferably substantially all of, the surface of the entrance device **12** facing the ion source **28**. Likewise, it is preferred that the conductive layer **36** of the exit device **14** cover at least a portion of, and more preferably substantially all of, the surface of the exit device **14** facing the ion filter **29**.

The ion detector **32** is preferably any suitable detector for detecting selected ions of the ion beam **22** in accordance with the invention, such as a Faraday-type ion detector or a single-particle multiplier detector.

With reference primarily to FIG. 4, the ion filter **29** is shown, including the poles **16**. The area **52** shown in FIG. 4 is that portion of the ion filter **29** shown in larger scale in FIG. 2. The connecting strips **50** radiate outward from the poles **16** and terminate in electrical connection with one of either bonding pads **44** or bonding pads **46**. One of the bonding pads (either **44** or **46**), the associated connecting strip **50** and the associated pole **16** are typically manufactured as an integral unit, as described more fully below with the discussion concerning preferred manufacturing methods for making the ion filter **29**. Also, the bonding pads **44** and the bonding pads **46** are offset, so that electrical connections may more easily be made to the bonding pads **44**, **46**. During operation of the mass spectrometer **10**, an rf frequency voltage and a DC voltage, as described previously, are applied to the poles **16** via electrical connections made to the bonding pads **44**, **46**. The specific frequency and magnitude of the rf voltage and the specific magnitude of the DC voltage applied to the poles **16** determine the value of m/z for ions passing through the ion filter **29** to exit with the mass filtered ions **30** for detection. By varying the frequency and/or voltages, the selected m/z for ions passing through the ion filter **29** may be varied. By continuously or periodically varying the rf frequency and voltages over a predetermined range, the mass spectrometer **10** may be used to scan for ions over a wide range of m/z values. The mass spectrometer **10** may be designed for m/z detection in the range of m/z of from about 1 to about 4000. For many applications, however, the range for m/z detection with the mass spectrometer **10** is from an m/z of about 1 to an m/z of about 300.

With continued reference to FIG. 4, the patterned layer of the ion filter is substantially entirely supported by the exit spacer **20**, which acts as a common supporting substrate. The exit spacer **20** has an opening **35** through the exit spacer **20**.

As the ion filter 29 is supported by the exit spacer 20, the opening 35 and the ion filter 29 are aligned so that at least the area 52 of the ion filter, including the poles 16 and portions of the connecting strips 50, are positioned over the opening 35. Therefore, the poles 16 and at least a portion of the connecting strips 50 are suspended from the exit spacer 20 over the opening 35. The opening 35 forms part of a pathway permitting ions from the ion source 28 to travel through the ion filter 29 to the ion detector 32. This pathway includes an entrance aperture 24 through the entrance device 12, an opening 37 through the entrance spacer 18, the quadrupole channels 17 (shown in FIG. 2) through the array of the poles 16, the opening 35 through the exit spacer 20 and the exit apertures 26 through the exit device 14.

It will be recognized that the relationship between the poles 16 and a common supporting substrate may involve different geometries in the mass spectrometer 10 without departing from the spirit of the invention. For example, the common supporting substrate could include a plurality of openings, rather than just one opening, with a different group of the poles 16 suspended over each of the plurality of openings. Also, the common supporting substrate could be used as an entrance spacer, rather than an exit spacer, with the ion filter supported on the side facing away from the ion source 29, rather than toward the ion source 29, as is shown in FIGS. 4 and 5, and an exit spacer could thus be used that is of similar design to the entrance spacer 18 as shown in FIGS. 4 and 5.

The mass spectrometer 10 may be operated at any convenient rf frequency. Typically, however, the length of the poles 16 (shown as the dimension L_p in FIG. 5) will be short enough to permit operation of the quadrupole mass spectrometer at low rf frequencies, such as frequencies less than about 50 MHz, which is generally preferred. This lower operational frequency allows the voltages V_0 and U_0 to be maintained at conveniently low values for the desired mass range to reduce the possibility of arcing across closely-spaced parts and to minimize power consumption in the electronics and radiation (varying as the sixth power of frequency). For example, a convenient length, L_p , of the poles 16 may range from about 2 mm to about 6 mm, as previously discussed, and may even be selected to be shorter than about 2 mm.

The use of short poles 16 and a Faraday-type ion detector allows operation at higher pressures, often in the millitorr range, wherein the particle's mean free path length may be comparable to instrument dimensions. As will be appreciated, operation at higher pressures allows the use of a smaller, less expensive backing pump to create the required vacuum conditions, rather than using, for example, a larger, higher-speed turbomolecular pump in combination with a backing pump.

The entrance device 12, spacers 18 and 20, bonding pads 44 and 46, and exit device 14 may have electrically conductive surfaces since they are located near charged-particle beams to produce known and fixed particle energies. As will be appreciated, the materials used to fabricate all the components preferably have coefficients of thermal expansion that are low enough to control distortion caused by operational temperature variations.

As noted previously, the poles 16 may have a hyperbolic shape (to follow the original Mathieu-equation formulation of the quadrupole problem). However, the poles 16 may also have other shapes with negligible loss in mass resolution, such as cylindrical (i.e., with a semicircle or other circle arc section at the terminal ends forming the poles 16). Other

shapes may provide easier final fabrication of plating molds (discussed below) for the poles 16 and, possibly, a denser packing of the poles 16.

During operation of the mass spectrometer 10, of a configuration as shown in FIG. 4, portions of the incident ion beam 22 passes through the entrance apertures 24 contained within the entrance device 12. Each of the entrance apertures 24 should correspond to and be aligned with one of the quadrupole channels 17 (shown in FIG. 2) within the array of poles 16, so that the entrance apertures 24 channel ions from the ion source 28 to the ion filter 29. Ions from the ion beam 22 that pass through the apertures 24 then travel through the array of the poles 16 of the ion filter 29. Ions exiting the ion filter 29 then depart through the exit apertures 26 contained within the exit device 14 as the mass-filtered ions 30 to be detected by the ion detector 32. Each of the exit apertures 26 should correspond to and be aligned with one of the quadrupole channels 17 (shown in FIG. 2) within the array of poles 16, so that the entrance apertures 24 channel ions exiting the ion filter 29 to the ion detector 32.

Detection sensitivity lost in miniaturization may be at least partially overcome by the use of numerous quadrupoles working in parallel as shown in FIGS. 4 and 5. As will be appreciated, miniaturization tends to reduce detection sensitivity because fewer particles can be admitted into the reduced entrance apertures 24 of the mass spectrometer 10. Thus, the basic pattern, described above and shown in FIGS. 2-5, can be repeated 1 to 10,000 times or more (depending on the desired results) to form a desired array of poles 16. Moreover, the poles 16 may be wired to all work in parallel, or different parts of the array of the poles 16 can be tuned to different mass ranges. As will be appreciated, variable control over operations of the spectrometer 10 may be useful when monitoring, for example, in an atmosphere or plasma, a transient phenomena, or a spatially-variable phenomena.

Referring now primarily to FIGS. 4, 6 and 7, a preferred manner for making electrical connections to the poles will now be described. FIG. 6 illustrates a perspective view of one type of bonding configuration and FIG. 7 shows a single quadrupole device for illustrating bonding configurations and electrical connections. The metal connecting strips 50 are attached between the bonding pads 44, 46 and the poles 16 to support the poles 16 of the ion filter 29 suspended over the opening 35 through the exit spacer 20 and to electrically connect the poles 16 to an rf generator (not shown). The bonding pads 44, 46 are each at a terminal end of the integral piece opposite the poles 16. The bonding pads 44, 46 provide additional structural strength for each connected pole 16 and for providing a site for wire bonding at the top of these structures as a secondary method of electrical connectivity.

As shown in FIGS. 6 and 7, the array of the present invention may have parallel wiring in an easy-access configuration. For example, dual tracks, a Track A 40 and a Track B 42, may be used with the dual bonding pads 44, 46 (one for each track) and the metal connecting strips 50 to electrically connect the bonding pads 44, 46 with the poles 16. The metal connecting strips 50 are connected to alternate positive (+) and negative (-) poles 16 of the quadrupole array. Outer metal Track A 40 and inner Track B 42 provide parallel access to the positive (+) and negative (-) poles 16, respectively. For example, all the positive (+) poles 16 may be connected to Track A 40, and all the negative (-) poles 16 may be connected to Track B 42, or vice versa.

The dual bonding pads 44, 46, one for Track A 40 and one for Track B 42, have a sufficient bonding surface, such as

approximately 1 mm by 3 mm. The bonding pad 44 of Track A 40 is preferably at least approximately 0.5 mm from Track B 42 so that there is sufficient clearance between Track A 40 and Track B 42. Electrical connectivity is realized by wire bonding, pressure contacting, or electroplating the structure from a previously-patterned substrate, such as exit spacer 20 of FIG. 4. The conducting poles 16, the connecting strips 50 and the bonding pads 44, 46, along with the dual tracks 40, 42 form the ion filter 29 for this embodiment. The exit spacer 20 (as shown in FIG. 4) preferably includes an electrically conductive bonding pattern 33, which is a patterned electrically conductive film that has a pattern that matches and corresponds with the pattern of the connecting strips 50 and the bonding pads 44, 46. The bonding pattern 33 enhances the ability to securely bond the ion filter 29 to the exit spacer 20. Furthermore, bonding of the connecting strips 50 and bonding pads 44, 46 securely to the exit spacer 20 maintains the poles 16 with the desired orientation with the poles suspended over the opening 35.

The present invention recognizes that several fabrication methods may be employed to produce the ion filter 29 of the present invention. It is important, however, that the manufacture method be such that the poles 16, as manufactured, have alignment and relative positioning for final use in a quadrupole mass spectrometer. This is typically accomplished by forming the patterned layer of the ion filter 29 so that it is all substantially supported by a common supporting substrate, such as the exit spacer 20.

One such method of the present invention for making the ion filter 29 quadrupole array includes the simultaneous fabrication of the poles 16, such as by simultaneously forming the poles 16, and typically also simultaneously forming the remainder of the patterned layer of the ion filter 29, in a mold by filling the pattern of the mold with electrically conductive material. In a preferred embodiment, the mold includes the pattern for all of the poles 16, the connecting strips 50 and the bonding pads 44, 46, which are all then fabricated simultaneously by filling the mold. As may be appreciated, the mold may be produced in a separate process or included as a step(s) in making the ion filter 29 of the present invention. Although other methods may be acceptable, one preferred means of creating the mold is through Lithographie-Galvanoformung-Abformung (LIGA) manufacture, discussed in more detail below. Similarly, any acceptable method may be used to fill the mold with electrically conductive material, such as, for example, by electroplating, chemical vapor deposition, physical vapor deposition, or loading voids in the mold with nanoparticles of the desired material. LIGA manufacture is particularly useful for poles 16 having lengths in a range of from about 0.5 mm to about 6 mm, and preferably of from about 0.5 mm to about 4 mm.

Another method of making the array of the poles 16 involves precise selective removal of portions of a work piece, that is initially a single solid sheet of electrically conductive material, to obtain the desired patterned layer for the ion filter 29. It is preferred that all of the poles 16, the connecting strips 50 and the bonding pads 44, 46 be manufactured from the same work piece and that the final patterning be done only when the single work piece is supported by a common substrate, such as the exit spacer 20. The selective removal may be any suitable technique. In this regard, Electrical Discharge Machining (EDM), discussed in detail below, may be employed to selectively remove material from the work piece and thereby obtain acceptable tolerances for poles 16. EDM manufacture is particularly preferred for manufacturing poles having a length of at least about 4 mm.

As will be appreciated, the use of the LIGA and EDM fabrication methods facilitates the production of poles 16 of a quadrupole array having the desired relative positioning of the poles 16 in a high density array. In this regard, the density and small size of the array is advantageously achieved by forming all of the poles 16 so that, as manufactured, the patterned layer, including the poles 16, the connecting strips 50 and the bonding pads 44, 46, is supported by a single substrate (e.g., the exit spacer 20). It should, however, be recognized that, although it is preferred that the method of the invention may be used to fabricate the entire patterned layer of an ion filter 29, the invention is not so limited. The method could be used, for example, to manufacture only an array of poles 16 in alignment, with electrical connections to the poles 16 being made other than through the connecting strips 50 and bonding pads 44, 46.

With EDM-based manufacture, all of the poles 16 and other portions of the patterned layer of the ion filter 29 are formed by selective removal of material from a single piece of electrically conductive material that has been first bonded to and supported on a common substrate (e.g., exit spacer 20). In the case of LIGA-based manufacture, the poles 16 and portions of the patterned layer of the ion filter 29 are formed in a single operation by filling a mold, with the mold being located over a common supporting substrate (e.g., exit spacer 20) so that the patterned layer of the ion filter 29 will be supported by the common supporting substrate. In this manner, proper alignment of the poles 16 is established concurrently with manufacture of the poles 16. By manufacturing the poles 16 so that, as manufactured, they are supported by a common supporting substrate, problems associated with positioning and aligning preformed rods, as is encountered with manufacture of conventional quadrupole devices, may be avoided. Rather, with the present invention, positioning and alignment of the poles 16 are accomplished during the same process operation in which the poles 16 are formed, considerably simplifying manufacture of the ion filter 29 by eliminating steps involving positioning and aligning loose, preformed rods.

METHOD OF FABRICATION USING A MOLD

The manufacturing method of the present invention will now be exemplified with a description of one embodiment of the method involving formation of an array of poles, and other portions of the patterned layer of the ion filter, by filling a mold. Preparation of the mold by the LIGA technique is also described, although it will be appreciated that the mold could be made by any suitable technique or could be acquired from an external source, such as an outside specialty manufacturer. FIG. 8 shows a process flow diagram illustrating one embodiment of the LIGA-based fabrication process of the present invention. It will be appreciated that the order of the steps is intended to be only illustrative in nature.

The LIGA method is employed in the present invention to manufacture a mold, which is also sometimes also referred to as a template. The mold may be made of any suitable material, but is typically a polymeric material, such as polymethyl methacrylate (PMMA) or a polyimide. A preferred material for the mold is PMMA. The discussion here will, therefore, be with reference to PMMA as an example of the mold material. The same principles apply to other mold materials. The molds are filled with an electrically conductive material to form the patterned layer of the ion filter, including an array of the poles. Because electroplating is a preferred method for filling the molds, the process is discussed with reference to electroplating by way of

example. The same principles apply, however, to other methods for filling the mold.

To manufacture a quadrupole mass spectrometer with the ion filter, other components such as entrance and exit devices and spacers are manufactured and then modularly assembled with the ion filter. The resulting quadrupole mass spectrometer is typically $\frac{1}{50}$ th, or smaller, of the mass and volume of present commercial quadrupole mass spectrometer devices. In that regard, the quadrupole mass spectrometer **10**, as shown in FIGS. **4** and **5**, may have a weight of smaller than about 7 grams and may occupy a total volume of smaller than about 2 cubic centimeters. Detection sensitivity lost in miniaturization may be at least partially overcome by fabricating the ion filter with a plurality of quadrupoles working in parallel, thereby increasing the area available for ion travel. For example, the ion filter of the present invention could include 10, 100 or even 10,000 or more quadrupoles. Although it will be appreciated that as the number of quadrupoles becomes very large, the size of the device will necessarily increase.

Using LIGA-based techniques, fabrication of the patterned layer of the ion filter is accomplished, for example, through electron-beam lithography (to manufacture repetitive gold LIGA X-ray masks using intermediate steps of contact-printing and gold-plating) followed by X-ray exposure of the PMMA in a synchrotron light source. The exposed PMMA is chemically developed away, the pattern of void spaces are filled by electroplating with electrically conductive material (gold or titanium is preferred), and exit and entrance spacers and entrance and exit devices having apertures are provided for assembly. After these components are aligned, assembled, and bonded together, an rf generator may be connected (e.g., through wire bonding techniques) and an ion source and ion detector provided to complete fabrication of a mass spectrometer.

LIGA-based processing is suitable to this manufacture because it is capable of producing high dimensional accuracy which allows the quadrupole array (e.g., poles) to be electroplated to a close tolerance, preferably to within a 0.1% dimensional tolerance. The LIGA method achieves this accuracy at least in part by using computer-aided mask manufacture to create masks used in fabricating the final template. To further improve the quality of the produced quadrupole array, advanced bonding techniques, such as anodic, diffusion, eutectic, or ultrasonic bonding, can be used to create contamination-free, corrosion- and temperature-resistant bonds without altering the dimensions of poles, connecting strips, and bonding pads.

One Embodiment of LIGA-Based Fabrication

With reference to FIG. **8** showing the sequence of processing steps and FIG. **4** showing various components of the quadrupole mass spectrometer **10**, one embodiment of LIGA-based fabrication of the patterned layer of the ion filter **29** is described.

(a) Fabricate Optical Mask

In this step, an optical photomask is fabricated for subsequent use in the fabrication of an X-ray mask. A standard electron-beam lithography apparatus is used to etch the "footprint" or pattern of the ion filter (i.e., poles **16**, connecting strips **50**, and bonding pads **44**, **46**) in a resist material coating a quartz substrate on which a UV opaque material, typically chromium, has been previously deposited. In this regard, the electron beam can be precisely controlled to an accuracy of about 1 nm in 1 cm. After exposure to the electron beam, the undesired resist material is developed away, and the entire mask is then placed in an etchant bath to remove the chromium film from the exposed

areas. The remaining resist is then removed leaving the previously-protected chromium pattern to be used as an optical mask for further lithography.

(b) Fabricate X-Ray Mask

The optical mask of step (a) is next used to fabricate an X-ray mask (to be used in the subsequent exposures in the synchrotron light source, see (c) below). The optical mask of step (a) is laid over a plate consisting of a 50 micron layer of photoresist coated over a 300 angstrom layer of gold, itself on a 50 angstrom layer of chromium, all supported on a silicon substrate. The assembly is then exposed to collimated ultraviolet (UV) radiation which replicates the pattern of (a) by passing through the quartz-only portions of the optical mask. Next, the undesired photoresist is developed away, and gold is then plated into these developed regions. As can be appreciated, this process creates a four-layer mask consisting of a patterned 50 micron gold layer on a 300 angstrom gold layer, itself on a 50 angstrom chromium layer, all on the silicon substrate.

(c) Expose PMMA Through X-Ray Mask

A PMMA sheet, having a thickness slightly greater than the final desired thickness of the patterned layer of the ion filter **29** is then exposed through the X-ray mask of step (b) to synchrotron X-ray radiation. The excess thickness is provided to accommodate lapping of the final structure, as discussed below. A synchrotron light source is used because it provides a collimated, intense beam of X-rays. These X-rays irradiate the PMMA sheet through the X-ray mask at the thin-gold locations. Because the X-rays are blocked by the thick-gold areas of the mask, the pattern of the ion filter is replicated in the PMMA sheet. A single X-ray mask may be used to pattern numerous PMMA sheets.

(d) Develop Exposed PMMA

The PMMA sheet of step (c) is then placed in a suitable mixture of solvents, such as methyl isobutyl ketone (MIBK), to dissolve the portion of the PMMA sheet exposed to X-rays in step (c). The solvent mixture is chosen so as not to dissolve or otherwise deteriorate portions of the PMMA sheet not exposed to X-rays. The resulting patterned PMMA sheet provides a template of the ion filter that can now be used as a mold that can be filled with electrically conductive material to form the patterned layer of the ion filter **29**, including the array of the poles **16** for the quadrupole array of the present invention. The process up to this point has been involved with making the mold. It should be recognized, however, that the mold could be made by any suitable technique or could be purchased in a premanufactured state from an outside source.

(e) Fill PMMA Mold

Using standard electroplating methods, the PMMA mold of step (d) may now be filled with a selected electrically conductive material (e.g., gold or titanium) to form the quadrupole array. To facilitate electroplating and further fabrication of the quadrupole mass spectrometer of the present invention, the PMMA mold may be placed on a electrically conductive base on a common supporting substrate (e.g., bonding pattern **33** on exit spacer **20**) that will form part of the finally assembled mass spectrometer. Because the exit spacer **20** is preferably fabricated from a electrically non-conductive material (e.g., ceramic or other dielectric), the electrically conductive bonding pattern **33** is bonded to the exit spacer **20** prior to placing the PMMA mold on the exit spacer **20**, typically by standard thin film or thick film deposition techniques. It will be appreciated that at this point in the manufacture process, the exit spacer **20** will not include the opening **35**, so that there will be a solid surface to electroplate against in the area that the opening **35** will eventually occupy.

A typical way to provide the bonding pattern **33** on the exit spacer **20** is to initially deposit a continuous film of electrically conductive material (e.g., gold) on the surface of the exit spacer **20** (i.e., the ceramic material is metallized). The pattern of the ion filter **29** is then lithographically imprinted in this electrically conductive film, and the exit spacer **20**, with the lithographically imprinted film, is placed in an etchant bath to selectively remove the electrically conductive film from the exposed areas, thereby forming the electrically conductive bonding pattern **33**. In this manner, the bonding pattern **33** is produced on, and bonded to, exit spacer **20**. The PMMA mold is now located on the exit spacer **20** so that the bonding pattern **33** is aligned with the pattern for the ion filter **29** in the PMMA mold. The PMMA mold is filled with the appropriate electrically conductive material (e.g., gold or titanium) by electroplating to the bonding pattern **33** that is exposed through the PMMA mold. The final electroplated structure is lapped (e.g., abrasive lapping with a fine-diameter slurry) to provide a flat planar surface having a desired surface finish for subsequent processing and to establish the desired final thickness of the patterned layer of the ion filter **29**, which is equal to the desired final length of the poles **16**.

(f) Dissolve PMMA Mold

After the filled PMMA mold has been lapped, the remaining PMMA of the mold is then dissolved in a solvent, such as methylene chloride, leaving a free-standing structure of the ion filter **29** (including the array of poles **16**, the connecting strips **50** and the bonding pads **44, 46**) bonded to the corresponding bonding pattern **33** and supported by the exit spacer **20**. Also, as will be appreciated, the mold may be removed by techniques other than dissolution in a solvent. For example, the material of the mold could be removed by laser ablation. The exit spacer **20** may be machined to create the opening **35** before or after the mold is removed. As will be appreciated, the opening **35** may be produced by employing various machining methods. A preferred technique is ultrasonic machining. For example, ultrasonic impact drilling may be used which involves placing an abrasive slurry in contact with exit spacer **20** and then using a tool, having the shape of the desired opening **35**, to rapidly (e.g., reciprocating vibrations at 15 to 30 kHz or higher) and forcefully agitate the fine abrasive materials in the slurry, thereby removing material of the exit spacer **20** to form the opening **35**.

The ion filter **29** may now be assembled with other components to make the quadrupole mass spectrometer **10**. For example, the entrance spacer **18**, typically of glass, may be placed on the exposed-and-lapped surface of the ion filter **29**, and the entrance device **12** then placed above the entrance spacer **18**. The exit device **14** may then be bonded or clamped to the underside of the exit spacer **20**. As will be appreciated, alignment of these components may be facilitated through the use of fiducial marks. The entire assembly may then be bonded in place using methods including, for example, the use of adhesives (of low vapor pressure, so as not to cause contamination), anodic bonding, thermal compression bonding, diffusion bonding, glass-to-metal seals, gold eutectic solder, or constraining the assembly in place through non-deforming mechanical clamping. The ion source **28** may then be coupled to the entrance device **12**, and the ion detector **32** connected to the exit device **14**, and an rf generator may be connected to the bonding pads **44, 46** to make the device functional.

It should be recognized that in the broadest sense, the manufacture method of the present invention involving the use of a mold to form the pattern of the poles **16** need not

include all of the steps described with reference to FIG. **8**. Rather, it is sufficient that a mold be used to form the pattern so that the poles **16**, as they are formed in the mold, have relative positioning and alignment for use in a quadrupole mass spectrometer.

METHOD OF FABRICATION USING EDM TECHNIQUES

FIG. **9** shows a process flow diagram illustrating one embodiment of the Electrical Discharge Machining (EDM) based process of the present invention. EDM is a machining process that selectively removes metallic material from a work piece by spark erosion. AC or DC current from a special generator is used to melt and vaporize conductive material away, rather than mechanically shearing tiny strips, as in conventional machining. Cooling and cleaning is usually provided by pumping deionized water through the cutting region. In the present invention, the electrode used to remove metallic material is a small-diameter (e.g., 0.001 inch) alloy wire which is driven by machines with accurate computer-controlled x, y, and z-drives. The machines are computer-programmed to give the desired final geometry and dimensions of the patterned piece.

One Embodiment of EDM-Based Fabrication

With reference to FIG. **9** showing the sequence of processing steps and to FIG. **4** showing various components of the quadrupole mass spectrometer **10**, one embodiment of EDM fabrication of the patterned layer of the ion filter **29** is described.

(a) Bond Work Piece to Substrate

A supporting substrate (e.g., exit spacer **20**) is provided having the bonding pattern **33**. To the bonding pattern **33** is bonded a single work piece, in the form of a sheet of electrically conductive metal (e.g., gold or titanium). The sheet preferably has a thickness that is substantially equal to the desired thickness for the final patterned layer of the ion filter **29**, and therefore also substantially equal to the desired final length of the poles **16**. The bonding pattern **33** may have been formed on the exit spacer **20** as previously described in the discussion concerning LIGA-based manufacture. Bonding of the work piece to the bonding pattern **33** on the substrate may be accomplished in any suitable manner. A preferred manner of bonding is by the use of solder placed between the bonding pattern **33** and the work piece. Also, it is preferred that at the time the work piece is bonded to the exit spacer **20**, the exit spacer already has the opening **35** therethrough. It is, however, possible to make the opening **35** after the work piece has been bonded to the exit spacer **20**, if desired. Also, the opening **35** may be made before or after the bonding pattern **33** has been formed on the exit spacer **20**.

(c) Pattern Work Piece

After the work piece has been bonded to the substrate, wire EDM is used to selectively remove material from the work piece to form the patterned layer of the ion filter **29**, including the poles **16**, connecting strips **50** and bonding pads **44** and **46**. The geometry and accuracy of the selections removed are controlled by the software and accurate x, y, and z directional drives and is preferably to within a 0.1% dimensional tolerance. As will be appreciated, the metallic work piece may have been at least partially patterned (through EDM or other methods) prior to being bonded in step (a) to the bonding surface on exit spacer **20**. For example, the bonding pads **44** and **46** and the connecting strips **50** may be at least partially patterned prior to bonding to the exit spacer **20**, simplifying the patterning of the work piece on the substrate. It is important, however, that the final

division of the work piece into the separate integral pieces for each of the poles **16** not occur until after the work piece has been bonded to the exit spacer **20**. In this way, the poles **16** are formed with the proper positioning and alignment for use in a quadrupole mass spectrometer, with the positioning and alignment being retained by the bond to the exit spacer **20**.

It should be appreciated that in its broadest sense, the EDM processing of the present invention does not require the first step shown in FIG. **9**, i.e., the bonding step. The substrate could be acquired from an outside supplier with the work piece already bonded to the substrate. It is sufficient that selective removal of material from the work piece bonded to the substrate occur in a manner such that the poles **16**, as they are formed, have the relative positioning and alignment for use in a quadrupole mass spectrometer.

After the work piece has been patterned into the patterned layer of the ion filter **29**, then the ion filter **29** may be assembled, along with other components, into the mass spectrometer **10**, in a manner as previously described.

As will be appreciated, the use of the above discussed LIGA-based and EDM-based fabrication processes facilitate the production of accurate, miniature quadrupole mass spectrometers with reduced complexity of manufacture relative to conventional manufacture of quadrupole mass spectrometers. It is anticipated that the reduced cost and advantageous size of the quadrupole mass spectrometer of the present invention will have many commercial applications. In this regard, the miniature quadrupole mass spectrometer of the present invention may be used for process control, personnel safety, and pollution monitoring. Also, the small size of the present invention allows small sensors containing the miniature quadrupole mass spectrometer to be manufactured. Commercial applications of the small sensors may include distributing the sensors throughout manufacturing plants, in public areas (such as buildings and subway systems), within plasma chambers (chip manufacturers), in earth-orbiting space stations, in long-duration human flight missions, for planetary aeronomy and planetary-surface studies, etc. Other commercial applications of the present invention may include automotive exhaust monitoring, home fire/radon/CO monitoring, personnel environmental monitoring, smoke-stack monitoring, and down-hole monitoring.

Also, because of the small size of the device, a high vacuum may not be required in some applications. This is because the requirement of small particle mean free path relative to the (small) spacing of the poles, as described above, can now be met with the present invention at a higher ambient pressure. This obviates the need for sophisticated pumping and can place devices of the present invention into the realm of operation of, for example, micromachined peristaltic pumps. Use at the higher pressures would require a pressure-resistant electron emitter (such as a field ionizer) to ionize the neutral species and a Faraday cup as the ion detector.

Furthermore, although the present invention has been described primarily in reference to the quadrupole mass spectrometer, the invention, in its broadest aspects is not so limited. Rather, one important aspect of the present invention relates to the ion filter described herein and methods for making the ion filter.

Moreover, while the invention has been described in combination with specific embodiments thereof, it is evident that many alternatives, modifications, and variations will be apparent to those skilled in the art in light of the foregoing description. Specifically, it should be understood that the order of the fabrication and assembly of the present inven-

tion may be altered from that given as an illustration. Further, it should be understood that a fabrication step may be omitted (e.g., by purchasing a prefabricated component) and still be within the spirit of the present invention. Accordingly, it is intended to embrace all such alternatives, modifications, and variations as fall within the spirit and broad scope of the appended claims.

What is claimed is:

1. A quadrupole mass spectrometer comprising:

an ion source to provide ions during operation of the quadrupole mass spectrometer;

an ion filter to filter ions supplied by said ion source during operation of the quadrupole mass spectrometer;

an ion detector to detect ions passing through said ion filter during operation of the quadrupole mass spectrometer;

said ion filter including at least 4 electrically conductive poles each having a length dimension in a direction from said ion source toward said ion detector, with a grouping of 4 adjacent of said poles defining a channel extending in said direction through which ions from said ion source pass for detection by said ion detector during operation of the quadrupole mass spectrometer; and

wherein, said poles are positioned such that said poles have a spacing density of greater than about 2 of said poles per square millimeter, as measured in a plane perpendicular to said direction.

2. A quadrupole mass spectrometer, as claimed in claim **1**, wherein said poles each have a surface which has a hyperbolic shape when viewed in a cross-section of said poles taken in a plane perpendicular to said direction.

3. A quadrupole mass spectrometer, as claimed in claim **1**, wherein said poles each have a surface in the shape of an arc of a circle when viewed in a cross-section of said poles taken in a plane perpendicular to said direction.

4. A quadrupole mass spectrometer, as claimed in claim **1**, wherein each said channel has a cross-sectional area, perpendicular to said direction, of smaller than about 0.05 square millimeter.

5. A quadrupole mass spectrometer, as claimed in claim **1**, wherein said poles each have a cross-sectional area, as measured in a plane perpendicular to said direction, of less than about 0.03 square millimeter.

6. A quadrupole mass spectrometer, as claimed in claim **1**, wherein said spacing density is greater than about 4 of said poles per square millimeter.

7. A quadrupole mass spectrometer, as claimed in claim **1**, wherein said spacing density is greater than about 6 of said poles per square millimeter.

8. A quadrupole mass spectrometer, as claimed in claim **1**, wherein said spacing density is greater than about 8 of said poles per square millimeter.

9. A quadrupole mass spectrometer, as claimed in claim **1**, wherein said spacing density is greater than about 10 of said poles per square millimeter.

10. A quadrupole mass spectrometer, as claimed in claim **1**, wherein directly opposing of said poles are separated by a distance of shorter than about 0.2 millimeter.

11. A quadrupole mass spectrometer, as claimed in claim **1**, wherein directly opposing of said poles are separated by a distance of shorter than about 0.15 millimeter.

12. A quadrupole mass spectrometer, as claimed in claim **1**, wherein directly opposing of said poles are separated by a distance of shorter than about 0.1 millimeter.

13. A quadrupole mass spectrometer, as claimed in claim **1**, wherein diagonally opposing of said poles are separated by a distance of shorter than about 0.3 millimeter.

14. A quadrupole mass spectrometer, as claimed in claim 1, wherein diagonally opposing of said poles are separated by a distance of shorter than about 0.25 millimeter.

15. A quadrupole mass spectrometer, as claimed in claim 1, wherein each of said poles has a first terminal end proximal to said ion source and a second terminal end proximal to said ion detector, with both said first terminal end and said second terminal end being located in a space between said ion source and said ion detector, such that the entire length of each of said poles is within said space between said ion source and said ion detector.

16. A quadrupole mass spectrometer, as claimed in claim 1, wherein said length dimension of each of said poles is shorter than about 6 millimeters.

17. A quadrupole mass spectrometer, as claimed in claim 1, wherein said length dimension of each of said poles is shorter than about 4 millimeters.

18. A quadrupole mass spectrometer, as claimed in claim 1, further comprising an ion entrance device located between said ion source and said ion filter, said ion entrance device including a first body of dielectric material, thereby being at least one of a first aperture extending through said entrance device to channel ions from said ion source to said ion filter.

19. A quadrupole mass spectrometer, as claimed in claim 18, wherein said entrance device comprises an electrically conductive layer covering at least a portion of a surface of said first body facing said ion source, such that the charge of ions from said ion source striking said electrically conductive layer may be dissipated.

20. A quadrupole mass spectrometer, as claimed in claim 19, wherein said electrically conductive layer is an electrically conductive metallic film adhering to and being substantially supported by said first dielectric body.

21. A quadrupole mass spectrometer, as claimed in claim 18, wherein said ion filter includes at least 6 of said poles and at least two of said channel, each said channel being defined by a different grouping of four adjacent of said poles; and

said ion entrance device includes a plurality of said first aperture, with each said first aperture corresponding with one said channel.

22. A quadrupole mass spectrometer, as claimed in claim 18, further comprising an ion exit device located between said ion filter and said ion detector, said ion exit device including a second body of dielectric material, there being at least one of a second aperture extending through said ion exit device to channel ions exiting said ion filter to said ion detector.

23. A quadrupole mass spectrometer, as claimed in claim 22 wherein said electrically conductive layer is exposed at a surface of said exit device inside of said first aperture.

24. A quadrupole mass spectrometer, as claimed in claim 23, wherein said exit device comprises an electrically conductive layer covering at least a portion of a surface of said second dielectric body facing said ion filter, such that the charge of ions exiting said ion filter that strike said electrically conductive layer may be dissipated.

25. A quadrupole mass spectrometer, as claimed in claim 24, wherein said electrically conductive layer is an electrically conductive metallic film adhering to and being substantially supported by said second dielectric body.

26. A quadrupole mass spectrometer, as claimed in claim 24, wherein said electrically conductive layer is exposed at a surface of said exit device inside of said second aperture.

27. A quadrupole mass spectrometer, as claimed in claim 23, wherein said ion filter includes at least 6 of said poles and at least two of said channel, each said channel being defined by a different grouping of four adjacent of said poles; and

said exit device includes a plurality of said second aperture, with each said second aperture corresponding with one said channel.

28. A quadrupole mass spectrometer, as claimed in claim 1, wherein said ion filter is supported by a substrate located between said ion filter and said ion detector.

29. A quadrupole mass spectrometer, as claimed in claim 28, wherein said substrate is of a dielectric material.

30. A quadrupole mass spectrometer, as claimed in claim 29, wherein said dielectric material comprises at least one of alumina and a glass.

31. A quadrupole mass spectrometer, as claimed in claim 28, wherein said ion filter comprises a patterned layer of electrically conductive material supported by said substrate.

32. A quadrupole mass spectrometer, as claimed in claim 28, wherein said ion filter comprises a plurality of electrical leads for supplying power to said poles during operation of the mass spectrometer, each of said electrical leads being interconnected with a different one of said poles; and

each of said electrical leads comprising a layer of electrically conductive material supported by said substrate.

33. A quadrupole mass spectrometer, as claimed in claim 32, wherein each of said electrical leads forms an integral piece with a different one of said poles, each of said poles comprising a first terminal portion of said integral piece.

34. A quadrupole mass spectrometer, as claimed in claim 33, wherein said integral piece comprise a layer of electrically conductive material of substantially constant thickness.

35. A quadrupole mass spectrometer, as claimed in claim 33, wherein for each said integral piece, at least a portion of one of said electrical leads and a corresponding one of said poles being an extension extending over an opening passing through said substrate, said opening through said substrate being part of a pathway for ions to travel between said ion source and said ion detector.

36. A quadrupole mass spectrometer, as claimed in claim 35, wherein there is only one said opening through said substrate, and each said extension, for each said integral piece, extends over said opening.

37. A quadrupole mass spectrometer, as claimed in claim 33, wherein each said integral piece further comprises a bonding pad at a second terminal end of said integral piece, said bonding pad providing a surface for making electrical connection to said integral piece.

38. A quadrupole mass spectrometer, as claimed in claim 37, wherein said bonding pad has a width that is larger than the width of said electrical lead, such that said bonding pad provides increased surface area for making an electrical connection to said integral piece.

39. A quadrupole mass spectrometer, as claimed in claim 1, wherein said poles have relative positioning, said relative positioning having been created simultaneously with manufacture of said poles, such that no relative repositioning of said poles is required, following said manufacture of said poles, for incorporation of said poles into the quadrupole mass spectrometer.

40. A quadrupole mass spectrometer, as claimed in claim 39, wherein said poles are manufactured by forming said poles such that said poles are supported by a common supporting substrate, such that said poles, as manufactured, have said relative positioning as supported by said common supporting substrate.

41. A quadrupole mass spectrometer, as claimed in claim 1, wherein said ion filter comprises at least 6 of said poles and a plurality of channels, each of said channels being defined by a different grouping of 4 adjacent of said poles.

42. A quadrupole mass spectrometer, as claimed in claim 41, wherein said ion filter includes at least 20 of said poles and at least 9 of said channels.

43. A quadrupole mass spectrometer, as claimed in claim 42, wherein said channels are positioned to have a spacing density of at least about 2 of said channels per square millimeter, with said spacing density being measured in a plane perpendicular to said direction.

44. A quadrupole mass spectrometer, as claimed in claim 41, wherein said ion filter comprises at least 100 of said poles.

45. A quadrupole ion filter, comprising:

a patterned layer of electrically conductive material, said patterned layer comprising at least 4 terminal ends each serving as a pole for at least one quadrupole, there being a quadrupole for each grouping of four adjacent of said terminal ends.

46. A quadrupole ion filter, as claimed in claim 45, wherein said patterned layer has a substantially uniform thickness.

47. A quadrupole ion filter, as claimed in claim 45, wherein said patterned layer has a thickness of smaller than about 6 millimeters.

48. A quadrupole ion filter, as claimed in claim 45, wherein said patterned layer comprises a plurality of separate electrically conductive pieces, each terminating in one of said terminal ends.

49. A quadrupole ion filter, as claimed in claim 48, wherein during operation of the ion filter, each of said pieces provides electrical connection to a different one of said terminal ends for providing electrical power to each said quadrupole during operation of the quadrupole ion filter.

50. A quadrupole ion filter, as claimed in claim 48, wherein said terminal end that serves as a pole is a first terminal end of each said piece; and

each piece comprises a second terminal end providing a bonding location for making electrical connection to an external power source for providing power to the ion filter.

51. A quadrupole ion filter, as claimed in claim 50, wherein said bonding location is suitable for making an

electrical connection to the ion filter by wire bonding to the bonding location.

52. A quadrupole ion filter, as claimed in claim 45, wherein said electrically conductive material comprises an electrically conductive metal.

53. A quadrupole ion filter, as claimed in claim 45, wherein said electrically conductive material comprises gold.

54. A quadrupole ion filter, as claimed in claim 45, wherein said electrically conductive material comprises titanium.

55. A quadrupole ion filter, as claimed in claim 45, wherein substantially all portions of said patterned layer are supported by a common substrate.

56. A quadrupole ion filter, as claimed in claim 55, wherein said substrate is substantially of dielectric material.

57. A quadrupole ion filter, as claimed in claim 55, wherein at least a portion of said patterned layer, including said terminal ends, are suspended from said substrate.

58. A quadrupole ion filter, as claimed in claim 57, wherein there is at least one opening through said substrate to provide a passage for ions, said portion of said patterned layer that is suspended from said substrate extending over said at least one opening.

59. A quadrupole ion filter, as claimed in claim 58, wherein said at least one opening comprises a plurality of openings, such that different portions of said portion of said patterned layer extend over different ones of said plurality of openings.

60. A quadrupole ion filter, as claimed in claim 55, wherein said patterned layer is supported on a side of said substrate having a surface area of smaller than about 10 square centimeters.

61. A quadrupole ion filter, as claimed in claim 55, wherein said substrate has a thickness of smaller than about 1 millimeter.

62. A quadrupole ion filter, as claimed in claim 45, wherein the quadrupole ion filter is in a quadrupole mass spectrometer, with said ion filter being located between an ion source and an ion detector.

* * * * *