

OVERCOMING PRESENT-DAY POWERPLANT LIMITATIONS VIA UNCONVENTIONAL ENGINE CONFIGURATIONS

P.L. Meitner*

Army Research Laboratory—Vehicle Technology Directorate
Cleveland, Ohio 44135

ABSTRACT

The Army Research Laboratory's Vehicle Technology Directorate is sponsoring the prototype development of three unconventional engine concepts - two intermittent combustion (IC) engines and one turbine engine (via SBIR (Small Business Innovative Research) contracts). The IC concepts are the Nutating Engine and the Bonner Engine, and the turbine concept is the POWER Engine. Each of the three engines offers unique and greatly improved capabilities (which cannot be achieved by present-day powerplants), while offering significant reductions in size and weight. This paper presents brief descriptions of the physical characteristics of the three engines, and discusses their performance potentials, as well as their development status.

1. INTRODUCTION

Present-day powerplants for Army air and ground vehicles, as well as power generation, fall into two broad, general categories – gas turbines and internal (or intermittent) combustion (IC) engines. Each category, in turn, can be further sub-divided into numerous subcategories. For example, gas turbines can be unrecuperated, recuperated, intercooled, or combinations thereof. IC engines can be piston or rotary, gasoline or diesel-fueled, spark ignited or compression ignited, turbocharged, supercharged, intercooled, or combinations thereof. While there are profound physical differences between the two powerplant categories, they are alike in one important aspect – their physical configurations have remained fundamentally unchanged since their inception. Improvements in performance have been incremental, and obtained mainly by increasing engine operating speeds, temperatures, and pressures. The engine operating conditions have increased to the point where existing material temperature and strength limitations are a severe roadblock to further substantial performance improvements. Since large material temperature and strength improvements do not appear to be on the horizon, further significant engine performance gains can only be obtained by fundamentally different, unconventional engine configurations.

2. THE NUTATING ENGINE

2.1 Nutating Engine Description

The Nutating Engine features a disk nutating (wobbling) on a Z-shaped power shaft. The disk nutates, and is prevented from rotating with the power (output) crank shaft via an anti-rotation pin. This provides lower seal velocities than a conventional piston IC engine. A single-disk Nutating Engine cross section is shown in Fig. 1(a), and the anti-rotation pin is shown in Fig. 1(b). This one-disk configuration performs the same functions as a conventional, 4-piston engine. Since power is transmitted directly to the output shaft, the complicated linkages needed in a conventional piston IC engine (to change the linear piston motion to rotating output motion) are eliminated.

In the engine's simplest, one-disk configuration, one half of the disk performs the intake/compression process, while the other half of the disk performs the burning/expansion process. The nutating motion of the disk produces a four-stroke cycle, and enables the displaced volumes to be used twice per engine revolution. Each process (intake/compression and power/exhaust) takes place over 270° of crank angle, and overlaps itself by 90° . Thus, there is always positive torque on the output shaft, making the Nutating Engine twice as power dense as a conventional two-stroke piston engine, and four times as power dense as a conventional four-stroke piston engine. Fig. 2 illustrates an "unrolled" schematic of the one-disk engine air flow. The compressed air charge from the intake/compression process (chamber) is collected in an accumulator and routed to combustion pre-chambers (on the power/exhaust chamber) at the appropriate power shaft crank angles. The disk can be configured to have either equal or unequal process volumes. Fig. 3 shows that, for equal process volumes, the engine cycle is the same as a conventional piston cycle, while a smaller intake/compression configuration results in a Miller cycle (for higher efficiency), and for a larger intake/compression volume, the engine is self-supercharged.

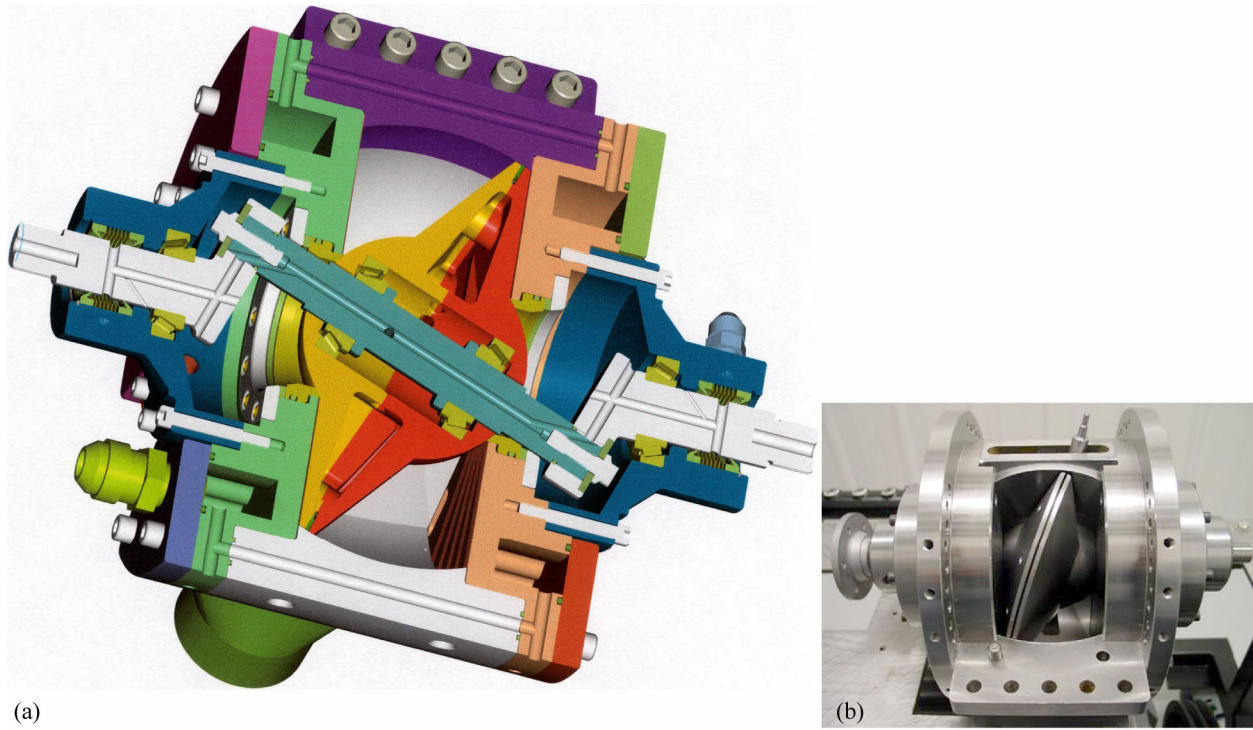

Fig. 1 (a).—One-disk Nutating Engine cross-section. (b).—Nutating Engine anti-rotation pin.

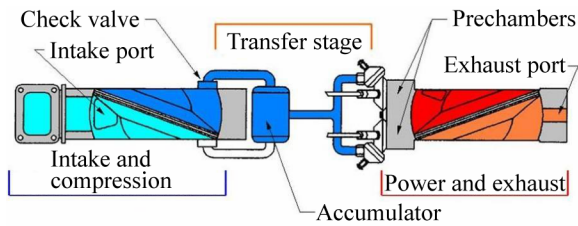

Fig. 2.—Nutating Engine air-flow schematic.

along the path of the disk. During its motion, the disk moves over and depresses the radial seals in an almost pure rolling motion (there is some sliding). Note that the outer surfaces of the disk never come in contact with the housing inner walls.

2.2 Nutating Engine Advantages

The Nutating Engine is ideally suited to burning heavy (diesel & JP8) fuel, since the shape of the combustion volume always retains a three-dimensional character, and the expansion (burning) process takes place over 270° of crank angle (versus 180° for a piston IC engine). This means that, for heavy fuel, the Nutating Engine can turn 50 percent faster than a piston engine before reaching the limiting speed set by the heavy fuel burning rate (flame front propagation speed). This increases power density.

The fact that the outer surfaces of the nutating disk never come in contact with the housing inner walls gives the Nutating Engine a distinct advantage over all other IC engines, since it allows the majority of the housing inner wall surfaces and the power/exhaust disk outer surfaces (except for the areas holding or making contact with the seals) to be thermal-barrier coated. This retains more heat in the combustion chamber, giving increased performance, while allowing a much smaller cooling system. In essence, the Nutating Engine comes close to the elusive goal of an adiabatic engine.

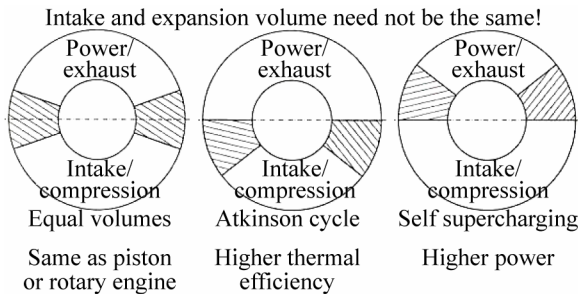

Fig. 3.—Intake/expansion volume comparison.

The unconventional nature of the Nutating Engine geometry requires unique seal configurations (shown in Fig. 4), the most critical being the radial seals, located on the insides of the housing side walls, placed every 10°

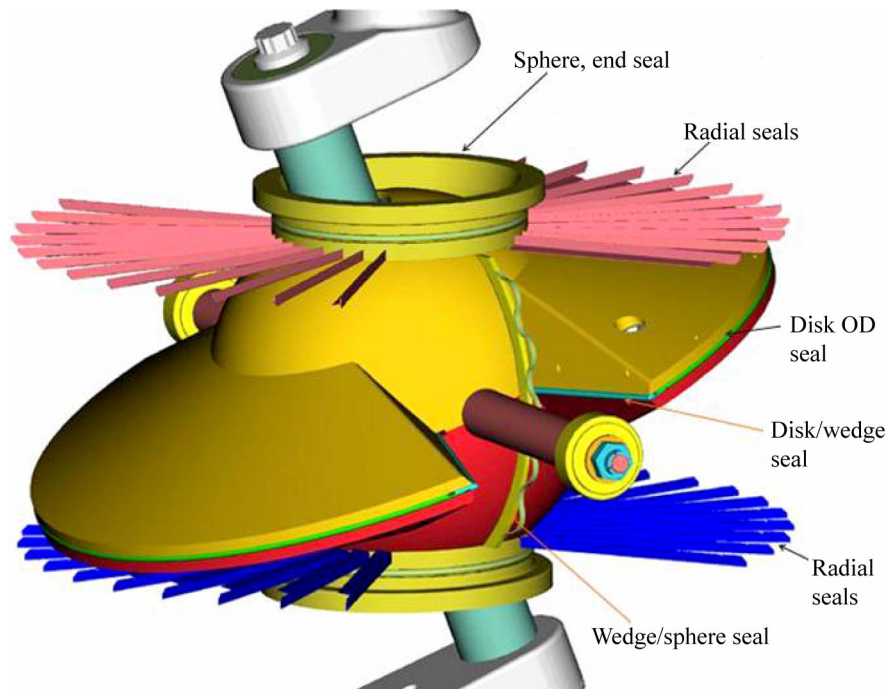

Fig. 4.—Nutating Engine seal configurations.

The Nutating Engine's exceptionally high power density and inherent simplicity make it the ideal choice for applications where small size and weight are the prime requirements (e.g., unmanned air and ground vehicles, auxiliary power units, and generators). A fully developed, heavy fuel UAV engine using two 5 in. (12.7 cm) diameter disks is projected to measure a very compact 16 in. (41 cm) long, 9 in. (23 cm) high, and 7.5 in. (19 cm) wide, and is conservatively predicted to produce 50 hp at 5000 rpm, and to weigh only 32.5 lb (14.77 kg), including all accessories.

2.3 Nutating Engine Development Status

A prototype, steel engine has been constructed and initial testing has been completed. To stay within the strict time and money constraints of an SBIR contract, a two-disk (8 in.-diameters) engine was constructed, with one disk (module) dedicated solely to the intake/compression process, and the other to the power/exhaust process. This allowed each module to be tested separately before the engine was assembled. In addition, a low (10:1) compression ratio was chosen, together with spark ignition and the use of gasoline as fuel. These steps greatly simplified the prototype engine development. The more challenging issue of operating on heavy fuel (and at pressure ratios allowing compression ignition) had to be postponed to be addressed in future efforts. The prototype engine (before instrumentation) is shown in Fig. 5. The intake/compression module performed exactly as designed, reaching design pressure ratio from the start. The power/exhaust module also performed well, increasing in

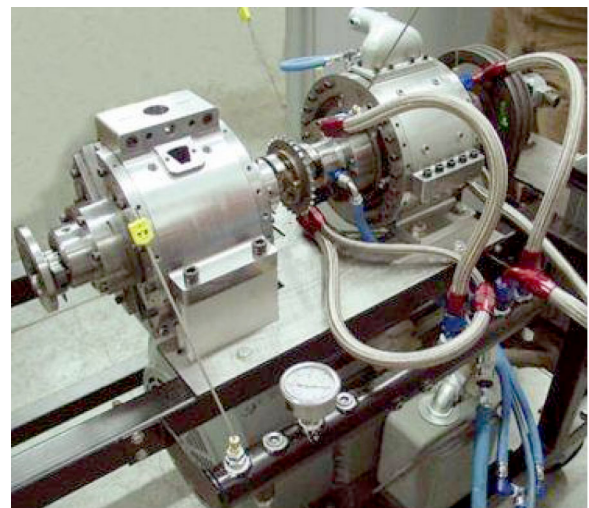

Fig. 5.—Prototype, 2-disk, Nutating Engine.

rotational speed when fuel was briefly injected, as it was being motored with high pressure shop air. High speed samples of chamber pressure were taken for every degree of module crank angle. The complete engine was fired and self-sustained, but no dynamometer data could be taken before the contract resources were depleted.

The limited testing performed so far has demonstrated the Nutating Engine concept's mechanical integrity and validated its thermodynamic cycle. The Air Force is continuing the development effort (also via an SBIR contract), concentrating on understanding the combustion process in this engine's unique geometry.

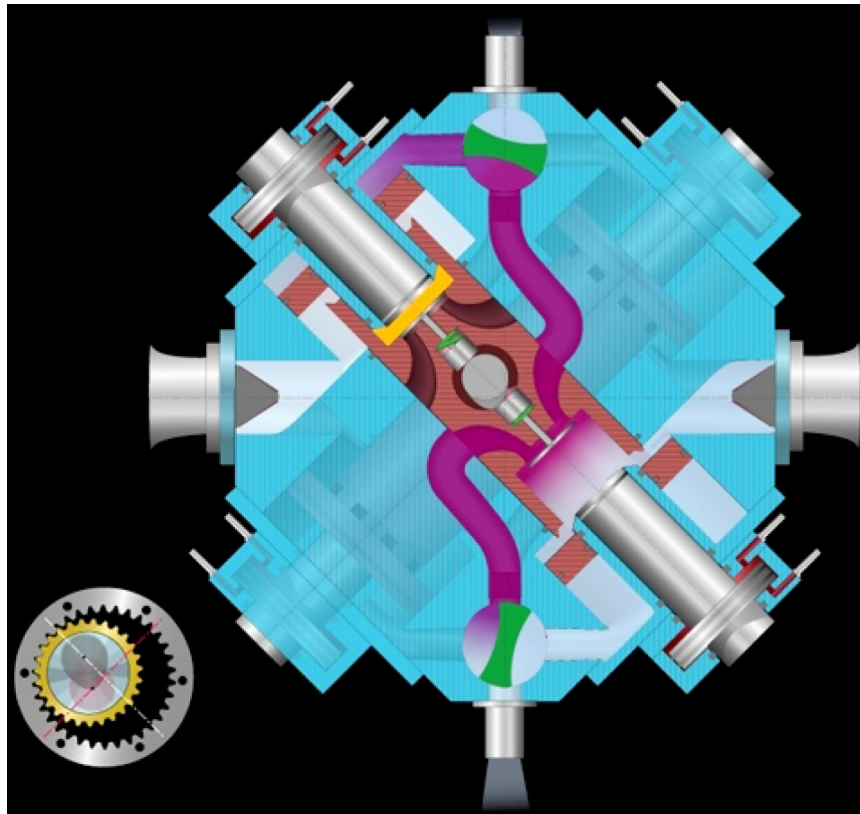

Fig. 6.—Bonner Engine cross section.

3. THE BONNER ENGINE

3.1 Bonner Engine Description

The Bonner Engine is an entirely new, two-stroke IC engine concept, in which the pistons are semi-fixed and the cylinders move in a reciprocating motion. Two cylinders reciprocate in a 90° X- configuration, each between two semi-fixed, movable pistons. The pistons contain the fuel nozzles and the spark plugs (for a gasoline engine). Each moving cylinder incorporates the intake and exhaust ports/valves and is open on its ends. These openings, together with the pistons, form the combustion chambers as shown in Fig. 6. Note that Fig. 6 depicts exhaust valves actuated by a cam on the output shaft. New technology is currently being patented which will eliminate the exhaust valve mechanism and replace it with a component which provides timed exhaust, and which will increase the effective stroke without increasing the reciprocating speed. This component will utilize exhaust ports in the moving cylinder. The Bonner Engine's geometric arrangement is made possible by a novel, dual-offset crankshaft which generates zero side loads on the cylinders and pistons. The crankshaft is shown in Fig. 7, with the arrows indicating the straight, linear motion of the moving cylinders. There is no piston rod or main bearing, and all pressure on the crank is power producing. Each reciprocating stroke is stopped and countered (at dead center) by compression and

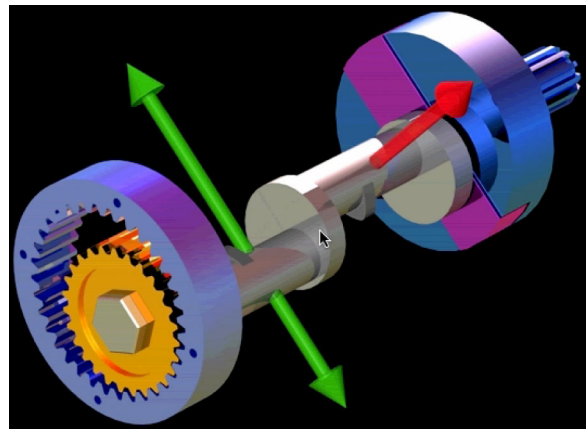

Fig. 7.—Bonner Engine crankshaft.

ignition, not by the crankshaft, as in a conventional piston engine. This provides two power pulses (each over 180° of crank angle) per moving cylinder for each revolution of the crank. The power pulses of the two moving cylinders are 90° out of phase, resulting in continuous torque on the output shaft, and a very smooth torque curve. Fig. 8 shows the cross section of a moving cylinder and a piston (for a spark ignited engine). A phantom view of the engine is shown in Fig. 9. The unique features of the Bonner Engine which differentiate it from all other IC engine concepts are as follows:

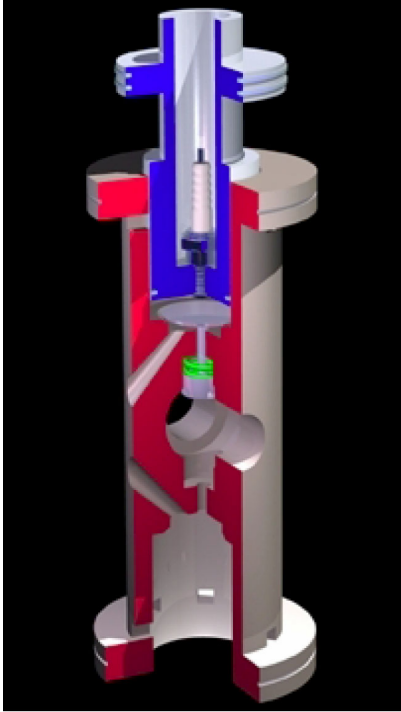

Fig. 8.—Bonner Engine moving cylinder and piston cross section.

3.1.1 Pre-Compression

A pre-compression chamber surrounds each end of the moving cylinder, as shown in Fig. 6. It provides an initial boost to the incoming charge (air). As the moving cylinder travels upward (to top-dead-center, TDC), air is drawn into the pre-compression chamber through a reed or rotary intake valve. The valve is actuated by the difference between the pre-compression chamber pressure and the ambient air pressure. When the moving cylinder reverses its direction and travels downward (to bottom-dead-center, BDC), the intake valve is forced shut as the pre-compression occurs. As the moving cylinder approaches its lowest downward position, intake ports are exposed which channel the pre-compressed air into the combustion chamber, where the final compression takes place.

The pre-compression chamber can be configured to provide a constant boost pressure, regardless of altitude or air density. This is achieved by a simple, patented ring piston configuration (not shown on Fig. 6) which automatically varies the pre-compression chamber volume and provides a constant boost pressure.

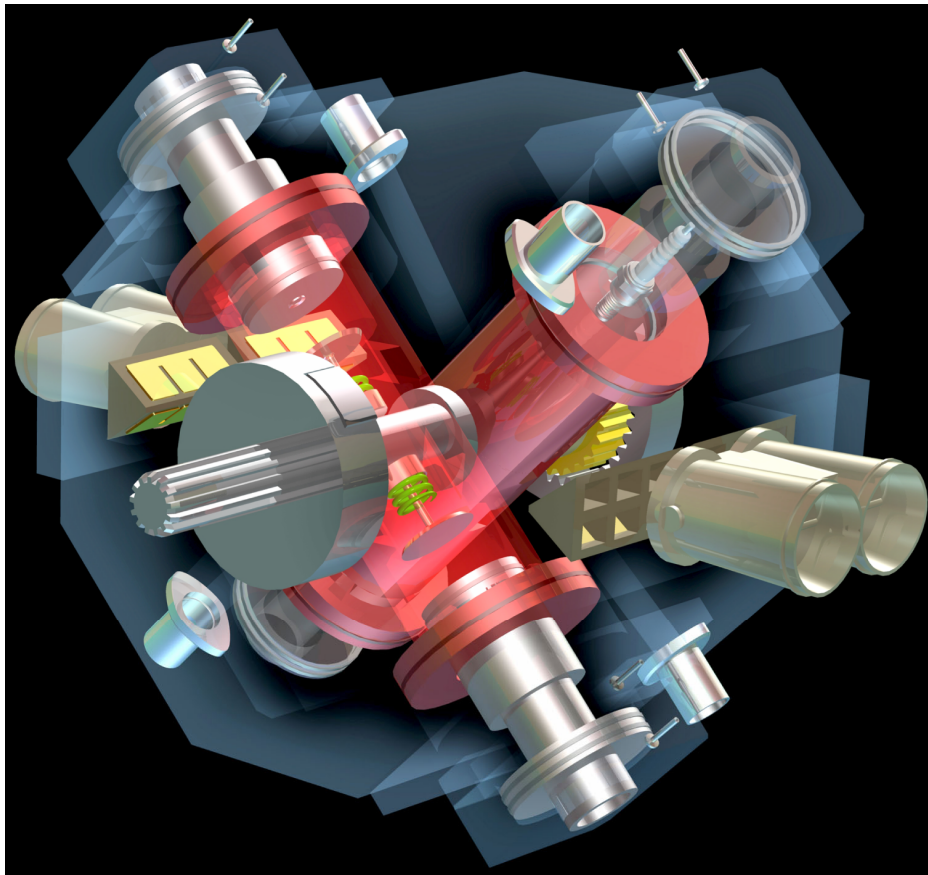

Fig. 9.—Bonner Engine phantom view.

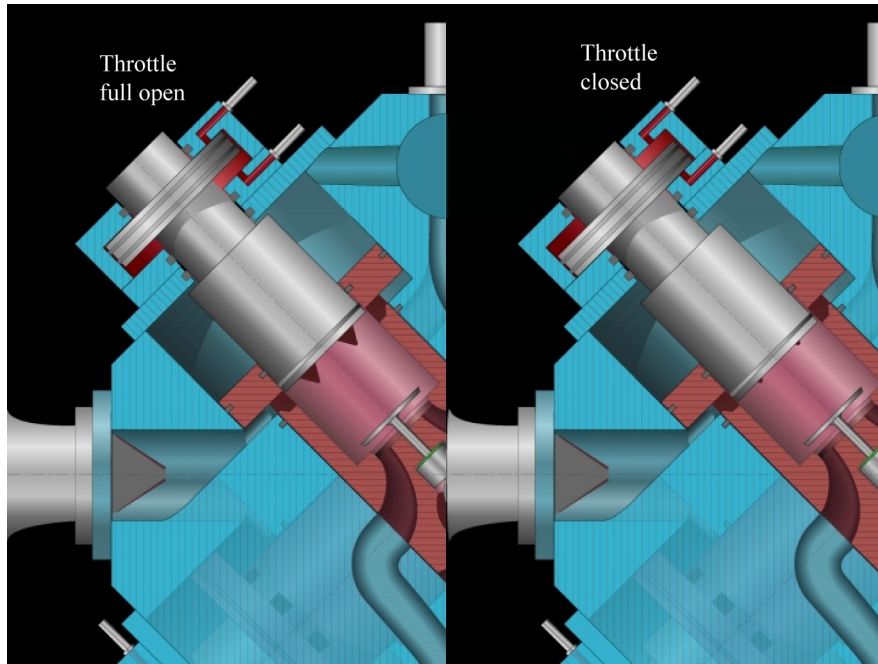

Fig. 10.—Bonner Engine piston positions.

3.1.2 Variable Compression and Induction

As can be seen in Fig. 6, the semi-fixed pistons fit into the ends of the moving cylinder. Each piston has a small range of motion (actuated hydraulically) which is used to continuously vary the overall compression ratio with engine speed. At low speed (idle) the piston is in its lowest (innermost) position, resulting in the highest overall compression ratio. At higher speeds the piston is moved progressively outwards, giving lower overall compression ratios (Fig. 10). The movement of the piston not only regulates overall compression ratio, but it also allows for continuous variation of air induction (simultaneously changing inlet size, timing and duration) with engine speed. This eliminates the need for a power robbing throttle plate (for a gasoline fueled engine). The fixed intake ports in the moving cylinder (which enable air flow from the pre-compression chamber into the combustion chamber) are exposed (opened) to a greater or lesser extent, depending on the position of the piston. When the piston is retracted for high speed operation, the ports are fully exposed to the incoming pre-compressed air and allow early, rapid filling of the combustion chamber. When the piston is at its lowest (innermost) position, only a fraction of the intake port area is exposed, thus limiting and delaying the amount of air inducted into the combustion chamber. Since only a fraction of the amount of air in the pre-compression chamber is admitted into the cylinder at low speed, the pressure in the pre-compression cylinder volume remains elevated. Consequently, the engine inlet reed or rotary valve will not open immediately, but is actuated later (by the

difference in pressures) by the moving cylinder's upward motion. Thus, the need for reduced air flow at low speeds is automatically compensated for by the pre-compression chamber.

3.1.3 Exhaust Energy Recovery

The Bonner Engine utilizes the energy in the exhaust to provide additional output power. As shown in Fig. 6, the exhaust passes through a rotary valve which, at the appropriate time, routes it to a chamber above the moving cylinder, helping to push the cylinder downward during its power stroke. During the moving cylinder's upward motion the rotary exhaust valve vents the exhaust overboard.

3.2 Bonner Engine Advantages

The Bonner Engine is exceedingly compact and light weight. The many unique features of this engine are combined in a deceptively simple and highly integrated manner. The Bonner Engine's configuration makes possible a combination of features which, up to the present, could only be obtained by complex and heavy add-on devices. To duplicate the Bonner engine's capabilities with a conventional piston engine would require, at a minimum, a supercharger, a turbocharger, and a complex, mechanical, variable-valve actuation mechanism. In addition, no conventional piston engine has yet to feature a workable variable compression ratio scheme which is as simple as that of the Bonner Engine.

The Bonner 2-stroke engine will be very clean burning. Unlike conventional 2-stroke engines, the Bonner Engine utilizes separate fuel and oil supplies, and conventional piston rings provide complete isolation between the lubricating oil and the fuel/air flow. Also, since the engine's combustion chamber intake and exhaust are located at opposite ends of the moving cylinder, the incoming charge does not have to change direction (between inflow and outflow, as in most 2-stroke engines), thus enabling uni-flow scavenging to be achieved. This, plus the totally controllable exhaust back pressure, combined with the variable intake charge timing assures that scavenging losses will be negligible – no unburned fuel will escape in the exhaust.

Because the Bonner Engine uses conventional piston configurations, all knowledge in existing data bases can be utilized to optimize the burning characteristics (for heavy or gasoline fuel), thus minimizing engine emissions. Also, the unique, two stage compression process of the Bonner Engine allows for the best possible mixing of fuel and air. This generates a very even combustion event, and offers an excellent chance of achieving Homogeneous Charge Compression Ignition (HCCI), the holy grail of piston engine research.

Most important, the Bonner Engine is unmatched in its ability to operate at maximum efficiency over its entire RPM range, and in its ability to deliver constant power at any desired altitude. It is expected to be the most fuel efficient intermittent combustion engine ever conceived. The Bonner Engine will greatly reduce fuel consumption for power generation applications, and will allow both air and ground vehicles to achieve significantly increased range and/or payload.

3.3 Bonner Engine Development Status

The Phase I SBIR effort has been completed. In this phase, the details of the altitude compensating pre-compression chamber were developed. A 600 cm³ prototype engine is being constructed under a current Phase II contract. The prototype engine will be tested under realistic operating conditions to verify the Bonner Engine's predicted attributes.

4. THE POWER ENGINE

4.1 POWER Engine Description

The POWER (POwer, Water Extraction, Refrigeration) Engine concept consists of a recuperated, semi-closed turbine engine cycle, synergistically coupled with a vapor absorption refrigeration system. The cycle diagram is shown in Fig. 11. Note that this cycle diagram is not drawn to scale. The POWER Engine provides power, as well as refrigeration, and it condenses and extracts most of the water produced by the combustion process and that

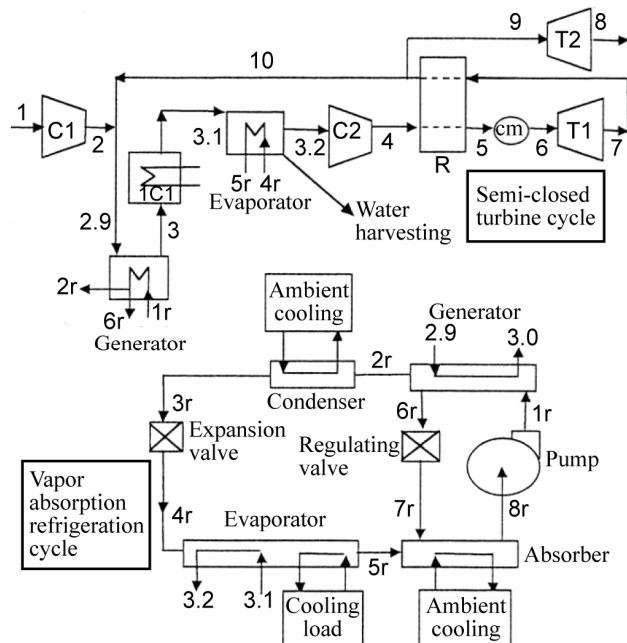

Fig. 11.—POWER Engine cycle schematic (not to scale).

present in ambient air. The semi-closed turbine cycle differs substantially from a conventional, open, recuperated turbine cycle (such as the AGT-1500 engine in the M1 battle tank), in that the major portion of the exhaust is “re-circulated” and cooled, and only enough fresh air is taken in to sustain combustion. The synergistically coupled vapor absorption refrigeration system is powered by the normally wasted heat that is rejected by cooling the recirculated gas. Part or all of the cooling capacity is used to suppress the high pressure compressor inlet temperature, significantly increasing both efficiency and specific work, while condensing water.

4.2 POWER Engine Advantages

The semi-closed turbine engine cycle has numerous advantages over an open, recuperated turbine cycle. They include: smaller and lighter turbomachinery components, a much smaller heat exchanger, greater fuel efficiency at part power (approaching that of a diesel), and much lower emissions. Also, the thermodynamic conditions (temperature, pressure, and water mole fraction) in a semi-closed turbine engine intercooler are ideal for efficient water extraction.

Unlike a diesel engine, the POWER Engine condenses water efficiently over its entire operating range, and the extracted water is clear, containing no soot, which facilitates cleanup. Cooling capacity and efficiency can be adjusted (traded off against each other) to suit specific applications; the extracted water can also be used for short-term power augmentation. The overall system is



Fig. 12.—Prototype POWER Engine layout.

far more efficient and smaller (half the size and weight) than any other system that consists merely of combined components (engine, refrigeration, and water reclamation).

The POWER Engine's compactness and exceptional fuel efficiency can ease the Army's transportation and power producing burden, while at the same time providing cooling for a multitude of applications. (e.g., refrigeration units for food, medical, and mortuary uses). In addition, its unmatched ability to condense and extract water at all operating conditions has the potential to greatly reduce the large logistics burden of providing sufficient quantities of water to the battle front.

4.3 POWER Engine Development Status

A prototype system has been constructed from existing, non-optimized components, and experimentally evaluated (Fig. 12). Note that the components were assembled solely to verify the concept, and that the prototype layout is in no way representative of a final engine configuration. Program goals were to achieve 80 hp, 5 tons refrigeration (1 ton refrigeration = 4.715 hp), and efficient water extraction. These goals were met, and all measured performance parameters were accurately predicted, showing that the underlying physics are well understood. The non-optimum prototype engine produced 0.7 lbs of water for every pound of heavy fuel (JP8) burned (at full power). For an optimized engine, calculations predict that almost 1 lb of water will be produced for every pound of fuel burned over a broad range of power.

CONCLUSION

The engine concepts described in this paper are truly revolutionary. Not only are they far lighter and more fuel efficient than existing engines, they also possess attributes significantly beyond those achievable with present-day Army engine configurations. In addition, they can be scaled over a wide range of horsepower requirements. The "best" engine for any specific application will be determined by the required duty cycle of that application. When fully developed and incorporated into Army systems, these advanced engine concepts will have major, beneficial impacts on Army operations.