

## Growing the First Stage of the Ares Launch Vehicles

*Rick Burt, First Stage Element Manager  
Tom Williams, Deputy First Stage Element Manager  
Exploration Launch Projects Office  
Marshall Space Flight Center  
Huntsville, AL 35812*

*Kent Call, Deputy Program Manager  
Fred Brasfield, Deputy Program Manager  
ATK Launch Systems  
Brigham City, UT 84302*

### Abstract

In accordance with the U.S. Vision for Space Exploration, NASA has been tasked to send human beings to the moon, Mars, and beyond.<sup>1</sup> The first stage of NASA's new Ares I Crew Launch Vehicle (Figure 1), which will loft the Orion Crew Exploration Vehicle into low-Earth orbit early next decade, will consist of a Space Shuttle-derived five-segment Reusable Solid Rocket Booster (RSRB); a pair of similar RSRBs also will be used on the Ares V cargo launch vehicle. This paper will discuss the basis for choosing the First Stage propulsion system; describe the activities the Exploration Launch Projects (ELP) Office is conducting to develop the first stage; and offer a preview of future development activities including the Ares I-1 test flight planned for 2009.

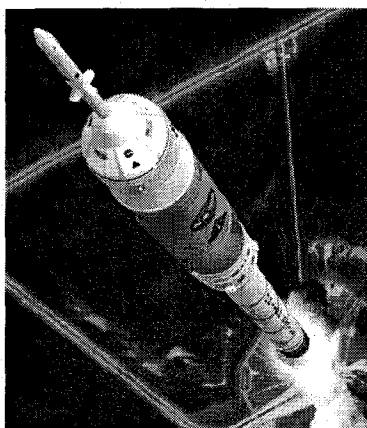

**Figure 1. Ares I crew launch vehicle (NASA artist's concept).**

NASA commissioned the Exploration Systems Architecture Study (ESAS) to provide recommendations for fulfilling the U.S. goals of providing human transportation to the International Space Station, returning to the Moon, and traveling on to Mars. The ESAS committee recommended using a two-vehicle approach for these missions, separating crew from cargo for added safety.<sup>2</sup> The Ares V cargo launch vehicle will go into orbit first, carrying the Lunar Surface Access Module (LSAM) in the Earth departure stage. Once the Ares V is in orbit, the Ares I crew launch vehicle will loft the Orion crew exploration vehicle into orbit to rendezvous with the Earth departure stage, which then ignites for the trans-lunar injection burn.

The original configuration for Ares I would have used a four-segment RSRB for the first stage and a Space Shuttle Main Engine (SSME) for the upper stage, while the Ares V would have used five SSMEs and two five-segment RSRBs for its core stage, followed by a Saturn-derived J-2X engine for the Earth departure stage.<sup>3</sup> After further engineering and business studies showed it would be more expensive to redesign the SSME to ignite in the upper atmosphere, the Constellation Program accepted the ELP team's recommendation to use a derivative of the J-2 engine that powered the Saturn V third stage to the Moon. However, because the J-2X produced less thrust than the

SSME, the first stage needed to be upgraded to provide additional thrust. This change proved valuable for two reasons:

- The five-segment RSRB still uses Shuttle-derived hardware, allowing NASA to draw upon existing institutional knowledge and infrastructure.
- The five-segment RSRB is also part of the Ares V core stage, so ELP can apply test data, hardware, and lessons learned by experienced personnel from Ares I to Ares V development.

ELP will benefit from NASA's long experience operating the four-segment Shuttle booster, as the five-segment unit will use the same casing, propellant, thrust vectoring system, and a similar nozzle design. ELP will also gain valuable assistance from the Shuttle Program in developing the five-segment motor, as both programs will share data from test and operational motor firings (Figure 2). More importantly, ELP's partner, ATK Launch Systems Group, performed static tests of a five-segment motor in 2003. Flight support tests conducted for the Space Shuttle Program continue to provide valuable data collection opportunities for the Ares program. RSRB Flight Support Motor (FSM) ground tests and Shuttle missions generate performance data that can be applied to both the Ares I and Ares V first stage.

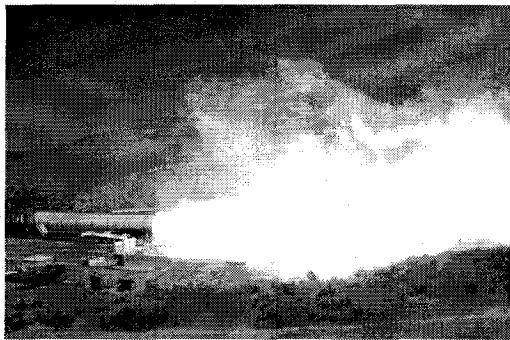

**Figure 2. Four-segment RSRB static test firing, April 2006.**

In addition to firing the motor, ELP is field testing critical RSRB subsystems, such as the launch recovery system. The Ares I tests collected performance data on a pilot parachute (Figure 3), the first to be unfurled in a three-part recovery system NASA is developing for the rocket's first stage. Derived from the Shuttle's RSRB recovery system, the Ares system includes a pilot, drogue, and three main parachutes. The 11.5-foot-diameter pilot chute was packed and mounted inside a 1,500-pound drop-test vehicle. Instruments and a recorder were mounted inside the test vehicle to capture data on the speed, weight on the parachute lines, and pressure during descent from an altitude of 10,000 feet. Additional tests will be conducted from higher altitudes to better simulate the velocity that the booster would experience after a typical ascent.

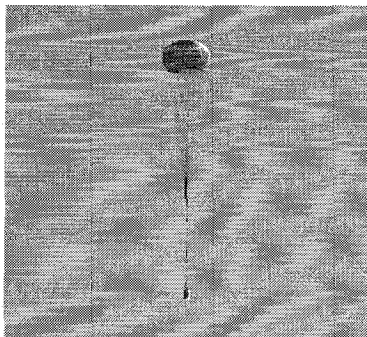

**Figure 3. Parachute recovery system test, August 2006.**

The Ares I-1 ascent development flight, slated for April 2009, gives NASA its first opportunity to gather critical data about the flight dynamics of the integrated launch vehicle stack, understand how to control its roll during flight, demonstrate the parachute, recovery, and retrieval systems, and better characterize the stage separation environment for future operational flights (Figure 4). The Ares I-1 flight profile will closely mimic the flight conditions, altitude,

and maximum dynamic pressure (Max Q) the five-segment launch vehicle experiences from liftoff through Mach 4.0. Mission elapsed time for first-stage burnout and upper stage separation also will be closely matched. The upper-stage simulator and the Orion Command Module/LAS simulator hardware will fall into the Atlantic and will not be retrieved. The First Stage booster will “fly” through a complete recovery sequence, and the hardware will be retrieved and analyzed. After recovery, the first stage hardware will be returned to the Kennedy Space Center for inspections and analysis. The data generated will provide information regarding actual hardware performance. The past flight data will allow engineers to assess predicted design margins against actual performance data. Design and processing modifications can be incorporated into subsequent flights if needed.

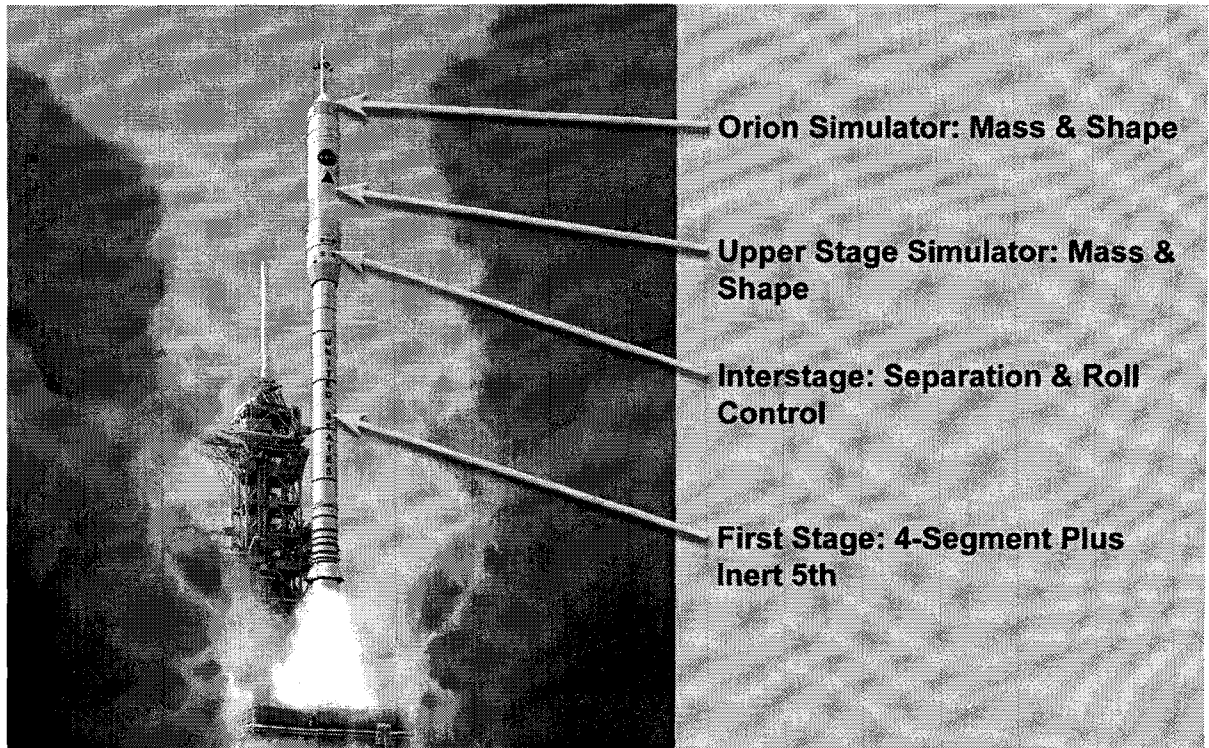

Figure 4. The Ares I flight test is planned for April 2009.

It has been 30 years since the United States last designed and built a human-rated launch vehicle. Our experiences with Saturn and the Shuttle have taught us the value of adhering to sound systems engineering, like the “test as you fly” principle, while applying aerospace best practices and lessons learned. We must employ a variety of methodologies to reduce the technical, schedule, and cost risks inherent in flying humans safely aboard a launch vehicle. The Ares I First Stage team is using these methodologies to be “first off the ground” when Ares I takes flight in 2009.

## References

- <sup>1</sup> National Aeronautics and Space Administration. *The Vision for Space Exploration*. February 2004.
- <sup>2</sup> National Aeronautics and Space Administration. *NASA’s Exploration Systems Architecture Study Final Report*. NASA-TM-2005-214062. November 2005.
- <sup>3</sup> Sumrall, John P., “A New Heavy-Lift Capability for Space Exploration: NASA’s Ares V Cargo Launch Vehicle,” *International Astronautical Conference*, 4 October 2006.

## Growing the First Stage of the Ares Launch Vehicles

*Alex Priskos, First Stage Element Manager  
Tom Williams, Deputy First Stage Element Manager  
Exploration Launch Projects Office  
Marshall Space Flight Center  
Huntsville, AL 35812*

*Kent Call, Deputy Program Manager  
Fred Brasfield, Deputy Program Manager  
ATK Launch Systems  
Brigham City, UT 84302*

### Abstract

In accordance with the U.S. Vision for Space Exploration, NASA has been tasked to send human beings to the moon, Mars, and beyond.<sup>1</sup> The First Stage of NASA's new Ares I Crew Launch Vehicle (Figure 1), which will loft the Orion Crew Exploration Vehicle into low-Earth orbit early next decade, will consist of a Space Shuttle-derived five-segment Reusable Solid Rocket Booster (RSRB); a pair of similar RSRBs also will be used on the Ares V cargo launch vehicle. This paper will discuss the basis for choosing the First Stage propulsion system; describe the activities the Exploration Launch Projects (ELP) Office is conducting to develop the First Stage; and offer a preview of future development activities including the Ares I-X test flight planned for 2009.

### Nomenclature

<i>ASA</i>	=	Altitude Switch Assembly	<i>JSC</i>	=	Johnson Space Center
<i>BDM</i>	=	Booster Deceleration Motor	<i>KSC</i>	=	Kennedy Space Center
<i>BTM</i>	=	Booster Tumble Motor	<i>LAS</i>	=	Launch Abort System
<i>CaLV</i>	=	Cargo Launch Vehicle)	<i>LOC</i>	=	Loss of Crew
<i>CDF</i>	=	Confined Detonating Fuse Line	<i>LOM</i>	=	Loss of Mission
<i>CDR</i>	=	Critical Design Review	<i>LSC</i>	=	Linear Shaped Charge
<i>CEV</i>	=	Crew Exploration Vehicle	<i>Max G</i>	=	Maximum Gravity
<i>CLV</i>	=	Crew Launch Vehicle	<i>Max Q</i>	=	Maximum Dynamic Pressure
<i>CM/LAS</i>	=	Command Module/Launch Abort System (simulator)	<i>Mlbf-sec</i>	=	Million pounds of force per second
<i>CP</i>	=	Cylindrical Port	<i>MPSS</i>	=	Main Parachute Support System
<i>DAC</i>	=	Design Analysis Cycle	<i>MSFC</i>	=	Marshall Space Flight Center
<i>DDT&amp;E</i>	=	Design, Development, Test, and Evaluation	<i>mT</i>	=	Metric Ton (Tonne)
<i>DFI</i>	=	Developmental Flight Instrumentation	<i>NASA</i>	=	National Aeronautics and Space Administration
<i>DM</i>	=	Development Motor	<i>PBAN</i>	=	Polybutadiene Acrylonitrile
<i>DTV</i>	=	Drop Test Vehicle	<i>PDR</i>	=	Preliminary Design Review
<i>EDS</i>	=	Earth Departure Stage	<i>PSA</i>	=	Production Simulation Article
<i>EELV</i>	=	Evolved Expendable Launch Vehicle	<i>RSRB</i>	=	Reusable Solid Rocket Booster
<i>ELP</i>	=	Exploration Launch Projects	<i>SDR</i>	=	System Design Review
<i>ESAS</i>	=	Exploration Systems Architecture Study	<i>SOMD</i>	=	Space Operations Mission Directorate
<i>ETR</i>	=	Eastern Test Range	<i>SRB</i>	=	Solid Rocket Booster
<i>FCDC</i>	=	Flexible Confined Detonating Cord	<i>SRM</i>	=	Solid Rocket Motor
<i>FITO</i>	=	Flight and Integrated Test Office	<i>SSME</i>	=	Space Shuttle Main Engine
<i>FS</i>	=	First Stage	<i>SW</i>	=	Space Wing
			<i>TLI</i>	=	Trans-Lunar Injection

*FSE* = Forward Skirt Extension  
*FSM* = Flight Support Motor  
*FTINU* = Flight Test Inertial Navigation Unit  
*FTS* = Flight Termination System  
*GNC* = Guidance, Navigation, and Control  
*IS* = Interstage

*TPS* = Thermal Protection System  
*TVC* = Thrust Vector Control  
*US* = Upper Stage  
*USE* = Upper Stage Engine

## I. Introduction: The Ares Launch Vehicles

The United States has committed to a new era of space exploration, beginning with a return to the Moon by the end of the next decade and human journeys to Mars and beyond in the decades that follow.<sup>2</sup> To execute these new missions, NASA will use lessons learned through the Apollo and Space Shuttle programs as well as technologies developed over 40 years of human spaceflight to build new launch vehicles. One of the lessons NASA has learned is to separate crew and cargo into two launch vehicles, resulting in the Ares I Crew Launch Vehicle (CLV) and the Ares V Cargo Launch Vehicle (CaLV)<sup>3</sup> (Figure 1).

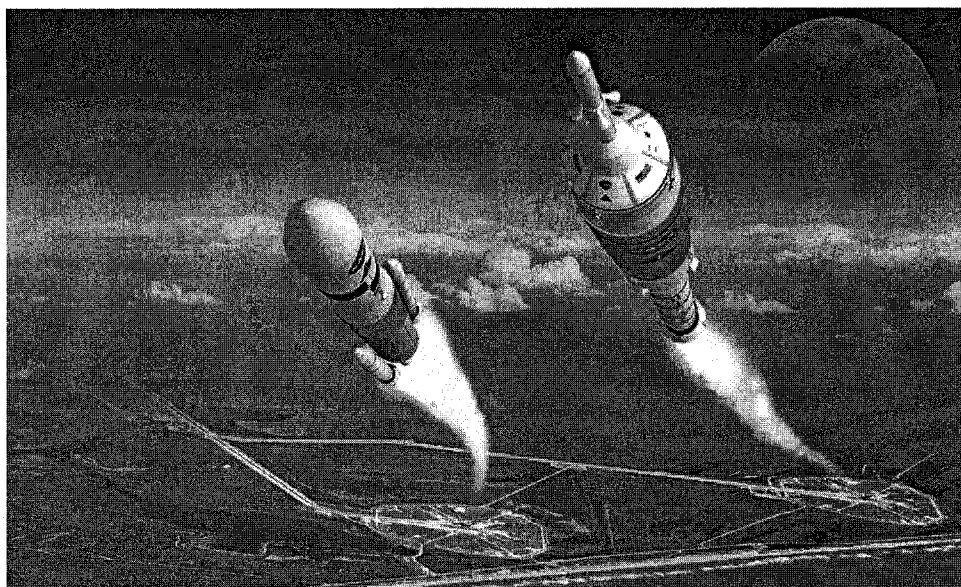

**Figure 1. The Ares V Cargo Launch Vehicle (left) and Ares I Crew Launch Vehicle (right) will form the backbone of America's new era of space exploration. (NASA artist's concept)**

Ares I serves as the crew launch vehicle for crew module for lunar and Mars missions as well as a crew and cargo transfer vehicle for the International Space Station (ISS). Ares I will be designed and flown first to reduce the gap in human spaceflight capabilities between the retirement of the Space Shuttle and the first flight of the Orion Crew Exploration Vehicle (CEV) to ISS in 2015. This vehicle is powered by a Shuttle-derived, five-segment Solid Rocket Booster (SRB) first stage and a liquid-fueled, Saturn-derived J-2X engine for its upper stage. Ares I also includes a Launch Abort System (LAS), which covers the Orion and moves it away from the vehicle quickly in the event of a malfunction. The LAS will provide a greater margin of safety than the side-mounted configuration of the Shuttle.

Ares V, which will begin full-scale development after the Shuttle's retirement, will be the largest launch vehicle ever built. With five commercial RS-68 engines (used on the Delta IV Evolved Expendable Launch Vehicle (EELV)) and two five-segment SRBs, the Ares V CaLV will generate 10.5 million pounds of thrust at liftoff. Ares V launches the Earth departure stage (EDS) into orbit, where it will await the launch and docking of an Orion CEV before providing a trans-lunar injection (TLI) burn (Figure 2).

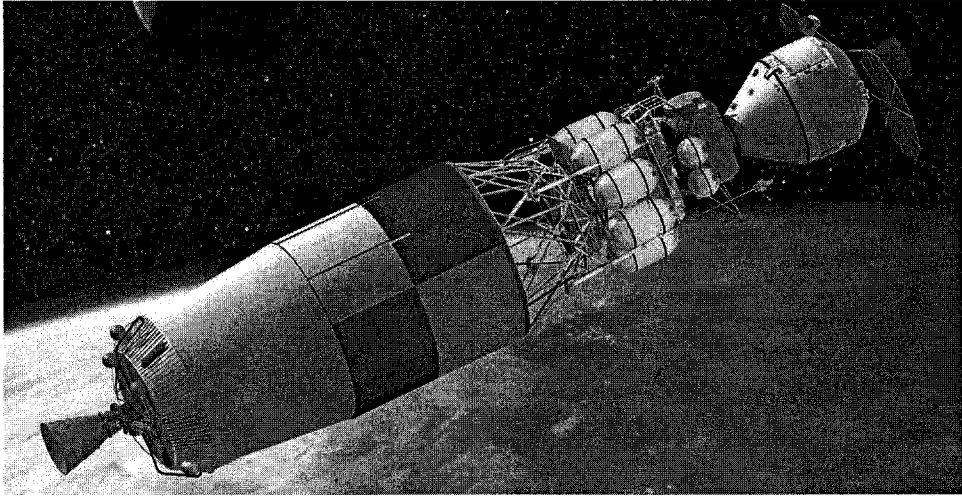

**Figure 2. The Ares V Earth Departure Stage will transport the Lunar Surface Access Module and the Orion Crew Exploration Vehicle to lunar orbit (artist's concept).**

The importance of using the same five-segment SRBs for Ares I and Ares V cannot be underestimated. By using a common solid motor design for both vehicles, data derived from the Ares I program can reduce the amount of effort required to prepare these boosters for Ares V.

## **II. ESAS and Ares – Origins of the Architecture**

NASA has continued to amend its approach to its new exploration mission since the Vision for Space Exploration (hereafter called “the Vision”) was first presented in 2004. Originally designed for exploration purposes only, the CEV’s mission was modified by Dr. Michael Griffin in 2005 when he became the new agency Administrator.<sup>4</sup>

As part of the new approach to the Vision, Dr. Griffin commissioned the Exploration Systems Architecture Study (ESAS) to provide recommendations for fulfilling the U.S. goals of providing human transportation to the International Space Station, returning to the Moon, and traveling on to Mars. The ESAS examined many different configurations to support the mission architecture, from vehicles using Space Shuttle-derived hardware to using upgraded versions of existing commercial Evolved Expendable Launch Vehicles (EELVs) (Tables 1 and 2). Among the considerations driving the architecture were payload to orbit, development costs, number of launches per mission, and safety factors such as loss of mission and loss of crew probabilities.

**Table 1. Crew launch vehicle concepts investigated during ESAS. The highlighted column indicates the configuration that most closely resembles the current Ares I. The ESAS study originally recommended the 4-Segment RSRB with 1 SSME.**

Feet 300  200  100							
	<b>Human-Rated Atlas V/New US</b>	<b>Human-Rated Delta IV/New US</b>	<b>Atlas Phase 2 (5.4-m Core)</b>	<b>Atlas Phase X (8-m Core)</b>	<b>4 Segment RSRB with 1 SSME</b>	<b>5 Segment RSRB with 1 J-2S</b>	<b>5 Segment RSRB with 4 LR-85</b>
<b>Payload (28.5°)</b>	30 mT	28 mT	26 mT	70 mT	25 mT	26 mT	27 mT
<b>Payload (51.6°)</b>	27 mT	23 mT	25 mT	67 mT	23 mT	24 mT	25 mT
<b>LOM (mean)</b>	1 in 149	1 in 172	1 in 134	1 in 79	1 in 460	1 in 433	1 in 182
<b>LOC (mean)</b>	1 in 957	1 in 1,100	1 in 939	1 in 614	1 in 2,021	1 in 1,918	1 in 1,429

**Table 2. Cargo Launch Vehicle concept comparisons. The highlighted column depicts the “1.5 launch” concept that most closely resembles the current launch architecture. As noted for Table 1, the ESAS originally recommended using a four-segment RSRB first stage and 1 SSME for the upper stage engine.**

Feet 300  200  100						<b>Cargo Only (Requires an additional CLV flight per mission)</b>	
	<b>5 Segment RSRB In-Line with 5 SSME Core – Cargo</b>	<b>Atlas Phase X (8 m Core)</b>	<b>Atlas Phase 3A (5.4 m Core)</b>	<b>5 Segment RSRB In-Line with 4 SSME Core</b>	<b>4 Segment RSRB In-Line with 3 SSME Core</b>		
<b>Payload (28.5°)</b>	106 mT (125 mT w/upper stage)	95 mT	94 mT	97 mT	74 mT	80 mT	67 mT
<b>LOM (mean)</b>	1 in 124	1 in 71	1 in 88	1 in 133	1 in 176	1 in 172	1 in 173
<b>LOC (mean)</b>	1 in 2,021	1 in 536	1 in 612	1 in 915	1 in 1,170	N/A	N/A

At the end of this process, the ESAS committee recommended using a two-vehicle approach for these missions, separating crew from cargo for added safety.<sup>5</sup> The Ares V cargo launch vehicle (CaLV) will go into orbit first, carrying the Lunar Surface Access Module in the Earth departure stage. Once the Ares V is in orbit, the Ares I crew launch vehicle will loft the Orion crew exploration vehicle into orbit to rendezvous with the Earth departure stage, which then ignites for the trans-lunar injection burn.

The original configuration for Ares I would have used a four-segment RSRB for the first stage and a Space Shuttle Main Engine (SSME) for the upper stage, while the Ares V would have used five SSMEs and two five-segment RSRBs for its core stage, followed by a Saturn-derived J-2X engine for the Earth departure stage.<sup>6</sup> However, further engineering and business studies showed it would be more expensive to redesign the SSME to ignite in the upper atmosphere. Thus, the Constellation Program accepted the ELP team's recommendation to use a derivative of the J-2 engine that powered the Saturn V third stage to the Moon. As a result of this decision, the first stage needed to be upgraded to provide additional thrust because the J-2X produced less thrust than the SSME. This change proved valuable for several reasons:

- The five-segment RSRB still uses Shuttle-derived hardware, allowing NASA to draw upon existing institutional knowledge and infrastructure, including an experienced workforce, known motor performance, existing tooling and manufacturing plants, and existing contractor relationships with ATK Launch Systems.
- The five-segment RSRB is also part of the Ares V core stage, so ELP can apply test data, hardware, and lessons learned by experienced personnel from Ares I to Ares V development.

ELP will benefit from the Space Operations Mission Directorate (SOMD's) long experience operating the four-segment Shuttle booster, as the five-segment unit will use the same casing, propellant, thrust vectoring system, and aft skirt, as well as a similar nozzle design. ELP also can gain valuable assistance from the Shuttle Program in developing the five-segment motor, as SOMD will share data from test and operational motor firings. More importantly, ELP's partner, ATK Launch Systems, has already performed static tests of a five-segment motor in 2003. The Space Shuttle Program flight support tests, which are performed with four-segment RSRBs, continue to provide valuable data collection opportunities for the Ares program. These tests also enable ATK and ELP to test Ares technologies on the Shuttle, such as a new, lightweight inside insulation.

Data collected from static and flight tests are shaping the final design of the Ares I launch vehicle, its hardware components, and its control subsystems. Building on proven propulsion systems has given designers a jumpstart on more advanced hardware testing. For example, RSRB Flight Support Motor (FSM) ground tests and Shuttle missions generate performance data that can be applied to the Ares I First Stage. Beginning with FSM-13, each RSRB ground test is being instrumented to collect data for Ares objectives. And, as stated earlier, this data will apply to the Ares V because it will use two similar RSRBs.

### **III. Current Ares First Stage Developments**

The Ares I First Stage, now well into the design stage, has been engaging in a variety of trade studies to determine the best design approaches for a variety of sub-elements.

#### **A. Structures**

In June 2007, the First Stage team completed a trade study regarding the use of metal versus composite materials for the new forward structures: the forward skirt, forward skirt extension, frustum, and aeroshell (Figure 3). The trade study focused on reusability, ease of manufacture, structural durability, and weight.



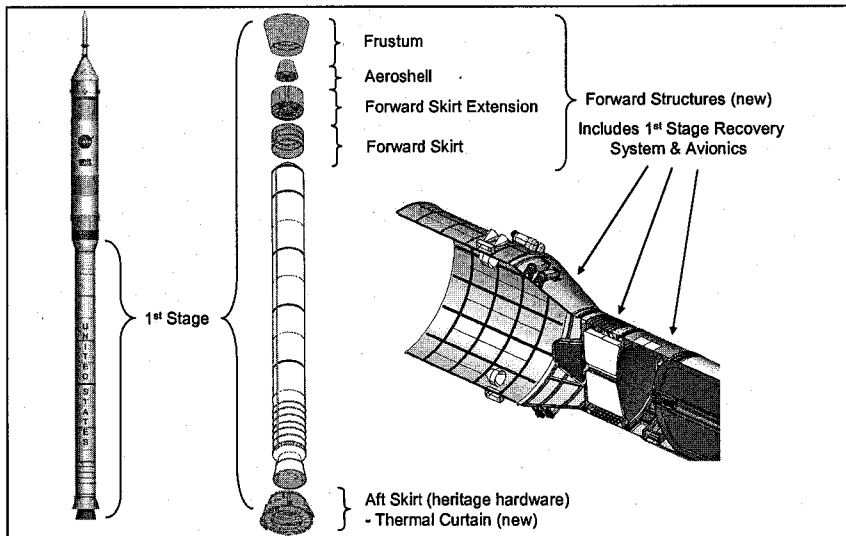
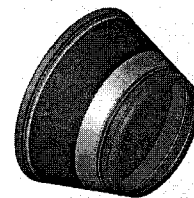

**Figure 3. Ares I First Stage forward structures.**

**Frustum**

A composite frustum was selected as the baseline for Ares I. It features an aluminum honeycomb composite structure with aluminum end rings. The various colors shown in Figure 4 identify changes in the composite layup (i.e. thickness). The layup changes to accommodate different structural stresses.

The frustum will continue to undergo study, as the J-2X Upper Stage Engine (USE) team might require a 26" X 30" access door to allow ground crew to access and remove the throat plug from the USE. The final configuration of the forward structures is pounds heavier than previously designed; this might require the Booster Tumble Motors (BTMs) to be remounted to take the weight change into account.



**Figure 4. Computer-aided representation of composite frustum.**

**Aeroshell**

A composite aeroshell was recommended for the Ares I as well. Composites were selected for the frustum and aeroshell because composite structures are more difficult to refurbish and because these two sub-elements are not going to be reusable. Like the frustum, the aeroshell will feature an aluminum honeycomb composite structure with an aluminum end ring (Figure 5).

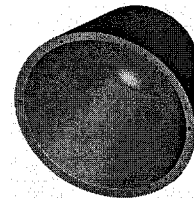

**Figure 5. Computerized representation of composite aeroshell.**

**Forward Skirt Extension (FSE)**

The forward structures, because they are reusable and integral to the overall First Stage structure, will continue to be made of metal. The FSE's current baseline is an aluminum-grid-stiffened structure with aluminum end rings. The individual barrel sections are bump formed and friction stir welded to each other; the completed barrel section is friction-stir-welded to the aluminum end rings. The forward and aft end rings include machined joints for attachment to the adjacent structures with bolts in tension. The top plate is an aluminum rib stiffened plate structure bolted to the top of the FSE (Figure 6).

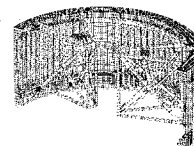

**Figure 6. Computerized representation of forward skirt extension.**

### **Forward Skirt**

The current baseline for the forward skirt is, like the FSE, an aluminum-grid-stiffened structure with aluminum end rings. The individual barrel sections are bump formed and friction stir welded to each other; the completed barrel section is friction stir welded to the aluminum end rings. End rings include machined joints for attachment to the adjacent structures with bolts in tension (fwd end) or shear (aft end). The bulkhead is an aluminum-rib-stiffened plate structure bolted to the top of the forward skirt (Figure 7).

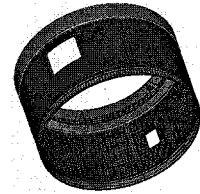
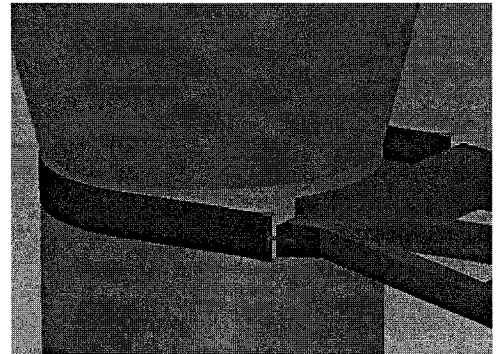

**Figure 7. Computerized representation of forward skirt.**

Forward work for the forward skirt includes developing the layout of the First Stage avionics and a reduction in the access door size. Also, the skirt will be shortened to reduce First Stage mass.

### **B. On-Pad Stabilization**

Given the massive size of Ares I, NASA engineers have been studying how to keep the vehicle upright and steady as it rolls out from the Vehicle Assembly Building to Launch Complex 39B. The sea breezes in Florida will inevitably result in some swaying until and even after the vehicle reaches the launch pad. Several stabilizing concepts and attach points are under study, including tie-down cables and hold-down posts for rollout and wrap-around clamps for on-pad stability. These various attach points, most of which connect or require hard points on the First Stage, affect the design of the forward structures. The First Stage team and KSC engineers are both involved in these studies. The First stage team at Marshall Space Flight Center (MSFC) would be in charge of designing the hold-down hardware, while KSC engineers would be responsible for building it. Figure 8 displays one possible wrap-around stabilization scheme.



**Figure 8. Conceptual design for wrap-around hold-down system to be used for on-pad stability.**

### **C. Motor and Propellant Developments**

While the RSRB is one of the most reliable and best known of the Ares vehicle elements, it still requires redesign for its new operational requirements. The Constellation Program required a First Stage capable of providing a particular thrust trace over time, leading to a redesign of the propellant grain's shape and formulation, as well as a redesign of the motor nozzle. In addition to these new designs and formulations, ATK Launch Systems is developing new tooling to manufacture the new hardware.

One new element addition that will aid in the progress of the First Stage is the funding of two additional development motors (DMs). These DMs will reduce technical risk; allow the team to pursue and evaluate parallel design options; and allow for a potential fault tolerance demonstration.

ATK Launch Systems and their subcontractors are building process simulation articles (PSAs) to help train their work forces in building the new hardware for Ares I. PSA development enables workers to build and streamline production processes before final production-quality hardware is built (Figure 9). Processes learned and honed in this environment will reduce cost and time later. Among the pieces

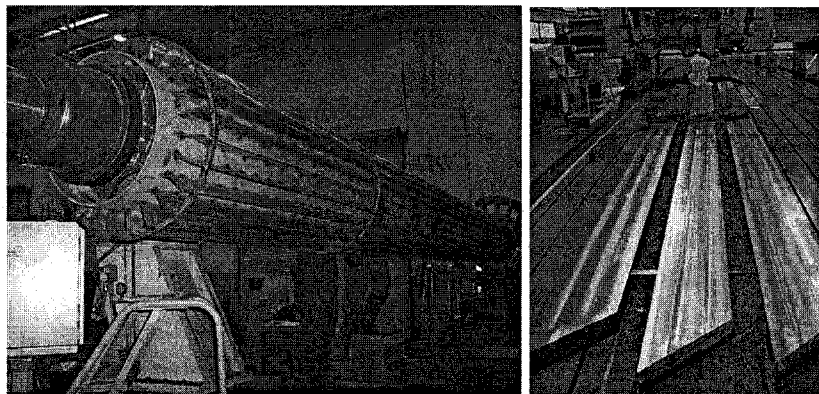

**Figure 9. Mandrel process simulation articles are being fabricated.**

undergoing this work are the mandrels, which are the molds around which propellant is poured in the motor segments.

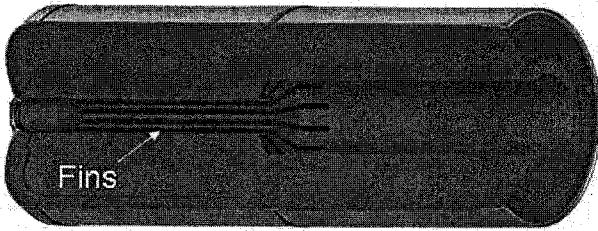

Figure 10. Cutaway view of RSRB forward segment.

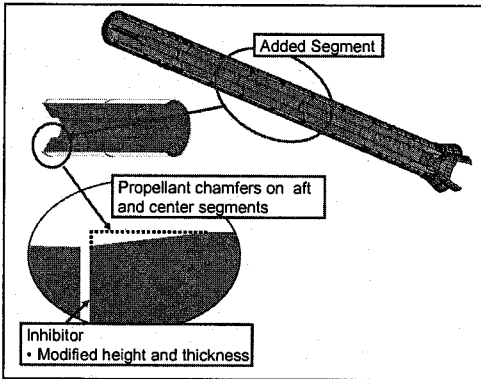

Figure 11. Cutaway views of segment chamfers and inhibitors

The new thrust trace requirement also requires a different burn rate, which results in a slightly different propellant formulation. The new variant of PBAN will include additional iron oxide, producing slightly longer burn time than the 4-segment Shuttle motor (124.3 seconds instead of 123.5 seconds) and a much higher total impulse (366.7 million pounds of force per second (Mlbf-sec) instead of 297 Mlbf.-sec) (Figure 12). Supporting this new propellant formulation will be a new internal insulation, which will be lighter and more environmentally friendly (asbestos-free) than the current insulation used on the Shuttle's RSRBs.

To use as much Shuttle-legacy hardware as possible, the exterior motor casings of the 5-segment motor have been remained the same diameter. However, given the additional segment and the longer boost time, the interior shape of the polybutadiene acrylonitrile (PBAN) propellant will be modified to both provide additional thrust while maintaining the same combustion chamber pressures as the 4-segment booster.

To increase performance, the number of "fins" by the igniter at the forward end of the propellant chamber was increased from 11 to 12, and the length of the "valleys" between those fins was reduced (Figure 10). This change increases the amount of surface area subject to combustion.

The second and fourth middle segments will include chamfers (bevels) and vertical inhibitors to ensure that the propellant burns evenly from the axis to the outer casing instead of burning (eroding) lengthwise down the bore of the propellant chamber (Figure 11).

Additionally, the nozzle needed to be widened because the motor is burning more propellant over a longer period of time. Widening the nozzle diameter ensures that more thrust can be generated and that internal pressure within the combustion chamber can remain within the tolerances specified for the Shuttle motor casings.

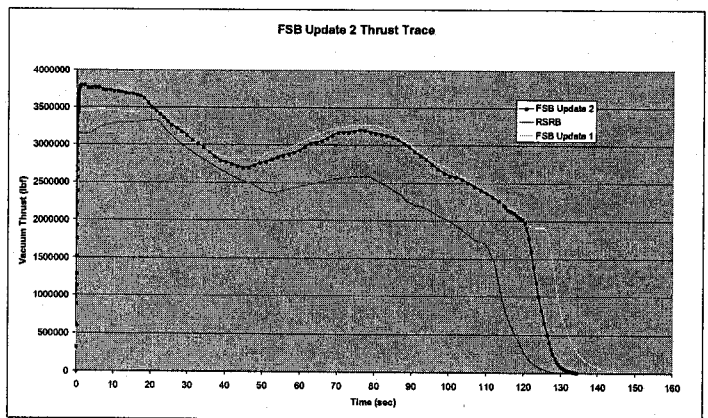

Figure 12. Nominal RSRB thrust trace.

The contractor partner developing the new insulation has performed structural and hot-fire tests with five-pound mixes, and has built full-scale production simulation articles to train their staff on manufacturing the new

formulation. The new insulations will be rolled into a static test motor in late 2008 and into a five-segment motor sometime after that.

The team has already manufactured and tested five-inch-diameter cylindrical port (CP) motors using the new propellant formulation. The CP motors will be tested to determine its mechanical properties, including tensile strength and ability to withstand stress.

#### **D. Avionics and Controls**

The team has made great progress on developing the First Stage avionics and control systems. The preliminary architecture has been defined, and the team has conducted a preliminary assessment of the Thrust Vector Control (TVC) system's performance requirements. The Shuttle-heritage TVC appears to meet the Ares I vehicle's requirements. Despite the vast difference in physical configurations, the Shuttle's performance requirements actually envelope those for Ares I.

Particular progress has been made on the Ares I-X Thrust Vector Control (TVC) system. While the flight tests' avionics hardware is mostly commercial-off-the-shelf, the avionics team is starting to map out the physical location and arrangement of the controller boxes as well as cabling within the FTV. The work receiving the most attention right now is the only new piece of hardware on the Ares I-X mission, the Ascent Thrust Vector Controller (ATVC) system. Because the FTV is using avionics from a liquid-fuel rocket (Atlas V), the system must be modified to control the solid-fuel SRB. The ATVC acts as the translation tool between these two systems (Figure 8). The final Ares I vehicle will use dedicated avionics and software not related to this system.

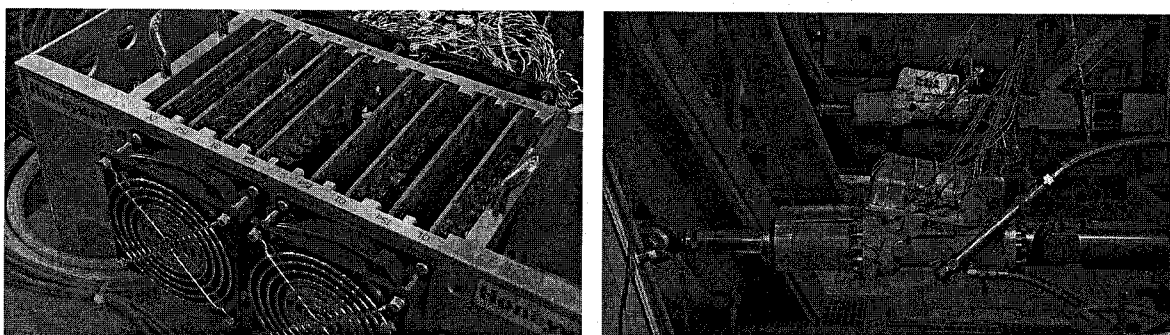

**Figure 13. Pictures of the Ascent Thrust Vector Controller (left) and SRB rock and tilt actuators (right).**

ATVC testing was completed successfully in Marshall Space Flight Center's Solid Rocket Booster actuator lab: in June. The testing went very well and demonstrated that the ATVC unit developed for the Ares I-X FTV provides all of the required functionality. In addition to the tests in the test plan, other tests were performed to characterize the end-to-end system gains and scaling factors for use in the flight control computer and for integrated vehicle testing in the Vehicle Assembly Building (VAB) at Kennedy Space Center (KSC).

Hardware-in-the-loop testing has begun at MSFC's System Integration Laboratory (SIL). The SIL will be used to conduct development and certification testing of the avionics system, its interfaces with control hardware like the Thrust Vector Control (TVC) system, and its ability to control the hardware. The aft skirt and TVC will be connected by fiber-optic cable to the SIL to verify interfaces and perform fault tolerance testing.

Several items are being developed for the operational Ares I vehicle, but they are not undergoing trade studies. These include:

- Working with the Upper Stage team to better define an architecture for commands between the First and Upper stage (several different options being studied). The issue here is examining how fault tolerance is approached in the command logic between the two stages
- Continuing to better define the Developmental Flight Instrumentation (DFI).
- Continuing to evolve the avionics as knowledge is gained, interfaces are defined more clearly, and requirements are established.

- Developing specifications to prepare for detailed design definition. Beyond better interface definition, more improvement in definition will come as part of the design process. The design process may identify weaknesses in the architecture, driving changes that will need to be addressed.

#### **D. Pyrotechnics / Pyro Shock Testing**

The pyrotechnics team recently completed a trade study on the use of Confined Detonating Fuse Line (CDF) versus Flexible Confined Detonating Cord (FCDC) for the separation pyrotechnics. The primary issue was using Shuttle-legacy materials (CDF) versus the less expensive and more readily available FCDC. The team decided to select FCDC.

The pyrotechnics group performed the first concept testing of the frangible (i.e. breakable) joint for the Ares I separation joints. They also completed the first phase of the separation linear shaped charge (LSC) characterizing tests for Ares I-X separation joints. These tests used a series of LSCs of differing strengths (based on grains per foot) to compare their effectiveness. The LSCs perform a dual function: acting as a cutting torch to sever the metal at the joints and to initiate an explosive shock to force apart the sub-elements. The shock effects of the LSC induce severe vibrations, which could damage the pyrotechnic cartridges used to jettison the nosecone/aeroshell on the forward end of the SRB. The final design of the separation pyrotechnic system will need to provide enough force to perform its separation function without damaging other components on the stage.

#### **E. Reusability Trade Study**

The First Stage team has been conducting a trade study regarding the merits of continuing to reuse the SRBs, or whether to switch over to expendable boosters for the vehicle. This study includes several significant figures of merit, including operational costs, vehicle performance, and reliability. A trade study was required because the costs and benefits is not clear-cut.

There are several factors in favor of going with an expendable booster, most of which derive from a simpler design. For instance, an expendable booster would not require parachutes or the forward skirt extension housing them. Other equipment, like Booster Tumble Motors (BTMs) or Thermal Protection Systems (TPS) would not be required because there would be little need to slow down or protect the booster as it reentered the Earth's atmosphere. Likewise, by eliminating parachutes, several pyrotechnic events and hardware components could be removed as well. This move toward simplicity also results in a potential increase in payload due to weight reductions in the First Stage. In addition to the reduced amount of flight hardware, expendable boosters would not require as much ground staff for preparation, assembly, recovery, or refurbishment, both at Kennedy Space Center and at ATK Launch Systems in Utah. Finally, because the five-segment SRB is so much larger than the four-segment Shuttle SRB, the First Stage team is still not certain if a recovery is possible. Much of that will be determined after the Ares I-X and Ares I-Y launches.

However, while expendable boosters appear to offer substantial cost savings, the potential downside also comes with potential costs due to a loss of reliability. Unlike liquid-powered engines, which can be tested on the ground and evaluated prior to launch, solid rocket motors can only be manufactured and assembled; operational effectiveness can only be determined during and after the mission. If the SRBs are allowed to splash down into the Atlantic Ocean and are not recovered, engineering and assembly personnel will not be able to tear down, inspect, and evaluate them after launch. Without the evaluation process, engineers will not be able to predict reliability as well; and the less reliable the booster becomes over time, the more expensive it might become. Procurement is another long-term cost that favors reusability. If boosters continue to be re-used, as they are in the Shuttle program, existing equipment can be used as long as 2040; however, if the boosters are made to be expendable, the government will have to purchase new SRBs starting around 2018.

This trade study is expected to be complete by late August, though the final analysis will take quite a bit longer.

## F. Staging and Separation Plane Trade Study

Another important trade study under way is addressing the physical separation process between the First Stage (FS) and Upper Stage (US). The primary concern the First Stage team has is with the Interstage (IS) structure striking the J-2X engine bell after separation from the Upper Stage.

This study was brought about due to the increased weight of the new forward structures. The present configuration of Ares I has the entire FS separating from the US in a single plane, at the top of the IS structure. However, because the weight of the forward structures has increased by as much as 30,000 pounds, the Interstage could fall downward more rapidly than the First Stage falls away and the Upper Stage accelerates forward. The clearance between the outer edge of the IS and the J-2X engine bell is in some cases as little as three inches (Figure 8).

The trade study is reviewing the possibility of using two planes of separation, jettisoning the FS above the frustum first to reduce the downward weight load and then jettisoning Interstage structure separately. The challenge of this approach is that the J-2X engine now has a skirt extension, making it longer than the end of the IS. This results in two possible impact threats to the engine.

A decision should be made on this study by the System Design Review (SDR), scheduled for autumn 2007.

## G. Ares I-X Flight Test

The Ares I-X ascent development flight, slated for April 2009, gives NASA its first opportunity to gather critical data about the flight dynamics of the integrated launch vehicle stack, understand how to control its roll during flight, and better characterize the severe stage separation environment that the upper stage engine will experience during future operational flights (Figure 10) NASA also will begin the process of modifying the launch infrastructure and fine-tuning ground and mission operational scenarios, as NASA transitions from the Shuttle to the Ares/Orion system.

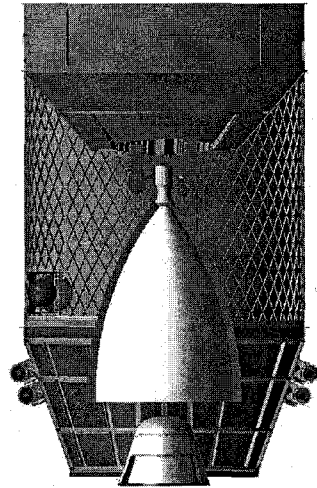

Figure 9. Interior arrangement of Ares I Interstage.

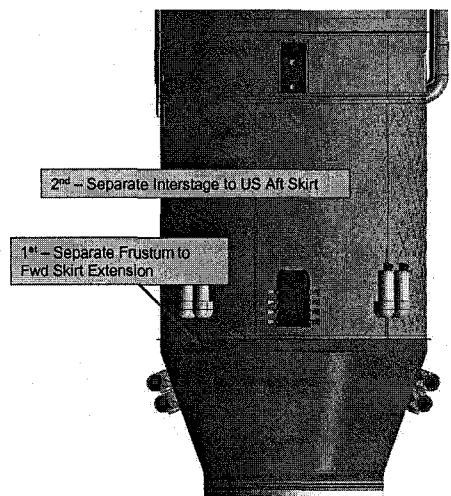

Figure 10. Locations of separation planes.

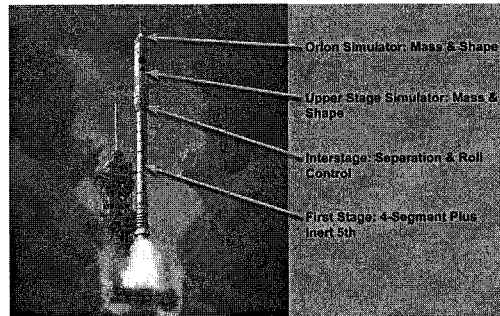

Figure 11. The Ares I flight test is planned for April 2009.

The Ares I-X flight profile will closely mimic the flight conditions the launch vehicle experiences through Mach 4.6 and at an altitude of approximately 150,000 feet through the maximum dynamic pressure quotient (Max Q) of nearly 800 pounds per square foot. Mission elapsed time for first-stage burnout and upper stage separation will be closely matched (within a few seconds), at about 130 seconds into flight. The upper-stage simulator and the Orion Command Module/LAS simulator hardware will fall into the Atlantic and will not be retrieved. The First Stage booster will “fly” through a complete recovery sequence, and the hardware will be retrieved and analyzed. After recovery, the first stage hardware will be returned to the Kennedy Space Center for inspections and analysis. The data generated will provide information on which to base hardware and software design decisions, as well as to fine-tune operations processes and products.

NASA’s contractor partners already have begun manufacturing tool and die equipment for the Ares I-X forward structures. This hardware, together with the exist four-segment SRB, must be delivered to Kennedy Space Center (KSC) for final assembly and vehicle stacking by August 2008 to ensure an April 2009 launch date.

#### IV. Future Work

For the remainder of calendar year 2007, the Ares I-X First Stage team will be conducting sub-element and component-level major design reviews to ensure that the vehicle specifications meet the stage and vehicle requirements. The Ares I-X test flight is still scheduled for April 2009. The next flight test after that will be Ares I-Y in 2012.

Meanwhile, work will continue on developing the First Stage hardware for the operational Ares I vehicle. This work includes:

- Drogue and main parachute tests are scheduled to begin in September 2007 and February 2008, respectively.
- The Ares I System Design Review (SDR) is scheduled for October 2007. The Preliminary Design Review (PDR) is scheduled for April 2008, to coincide with the vehicle PDR. The Critical Design Review (CDR) is scheduled for November 2010.
- The first Development Motor (DM) is schedule to begin fabrication in late 2007.

#### Conclusion

The Ares I and Ares I-X First Stage teams are actively pursuing the design and development of propulsion hardware for America’s next generation of human-rated launch vehicles. The Ares I-X test in April 2009 will begin the process of validating the designs of the new forward structures on the stage. Additional trade studies are under way to ensure that safe, reliable, and cost-effective decisions are made prior to the first crewed launch in 2013. NASA’s extensive experience with this Shuttle-legacy hardware, plus its efforts to improve upon it, will help ensure the continued human exploration of space for decades to come.

#### References

- <sup>1</sup> National Aeronautics and Space Administration. *The Vision for Space Exploration*. February 2004.
- <sup>2</sup> Ibid.

---

<sup>3</sup> National Aeronautics and Space Administration. *NASA's Exploration Systems Architecture Study Final Report*. NASA-TM-2005-214062. November 2005, p. 21.

<sup>4</sup> Ibid, p. 1.

<sup>5</sup> Ibid.

<sup>6</sup> Sumrall, John P., "A New Heavy-Lift Capability for Space Exploration: NASA's Ares V Cargo Launch Vehicle," *International Astronautical Conference*, 4 October 2006.



National Aeronautics and Space Administration

# Exploration Launch Projects

## Growing the First Stage of the Ares Launch Vehicles

**Alex S. Priskos**  
*Manager*

**Thomas L. Williams**  
*Deputy Manager*  
*Ares I First Stage Office*

*AIAA Space 2007*  
*September 2007*

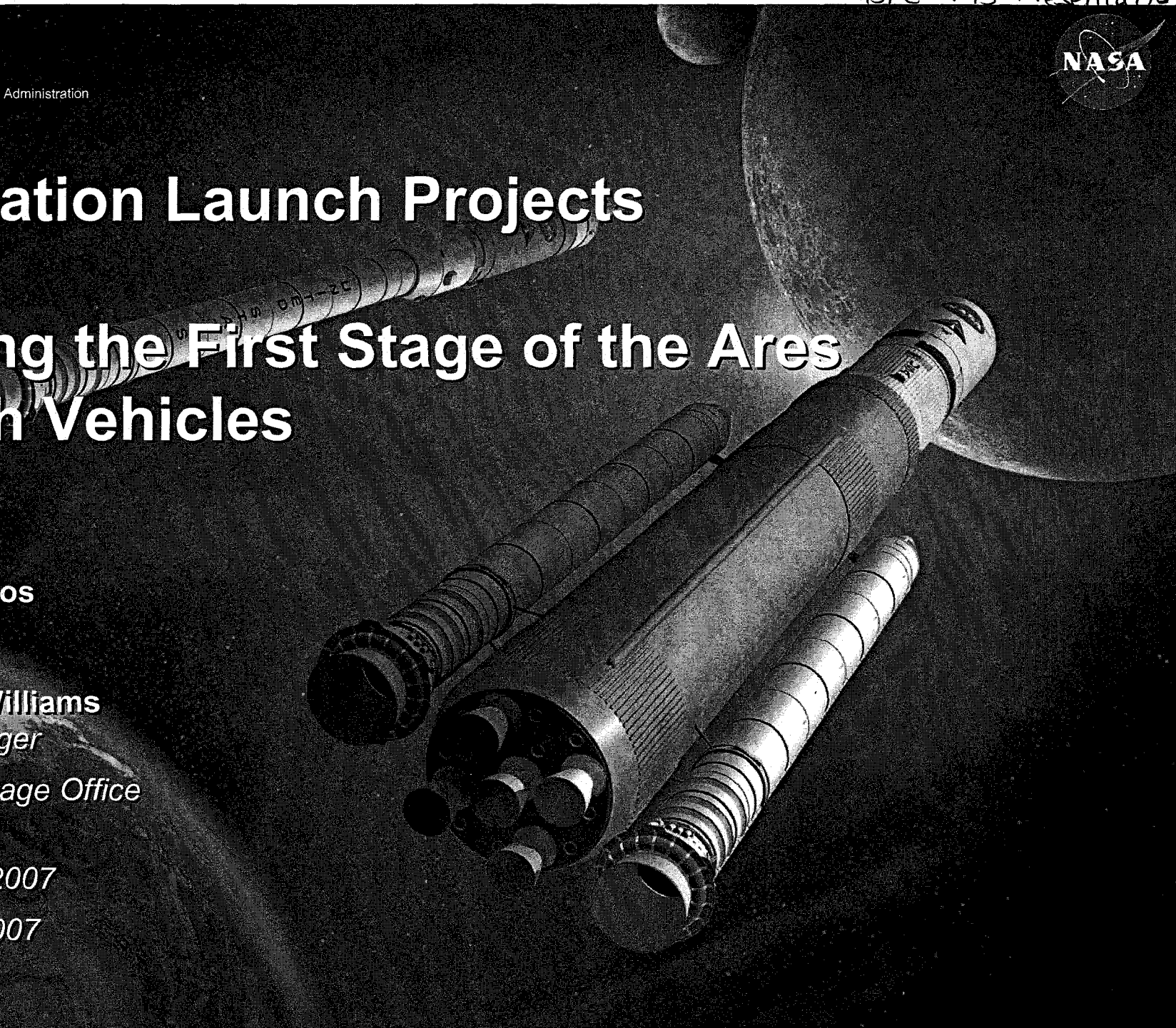



# Agenda

---



- ◆ **Overview and history of the Ares Launch Vehicles**
- ◆ **Progress on current propulsion elements**
- ◆ **Forward work**



# Overview of the Exploration Launch Projects Architecture

---

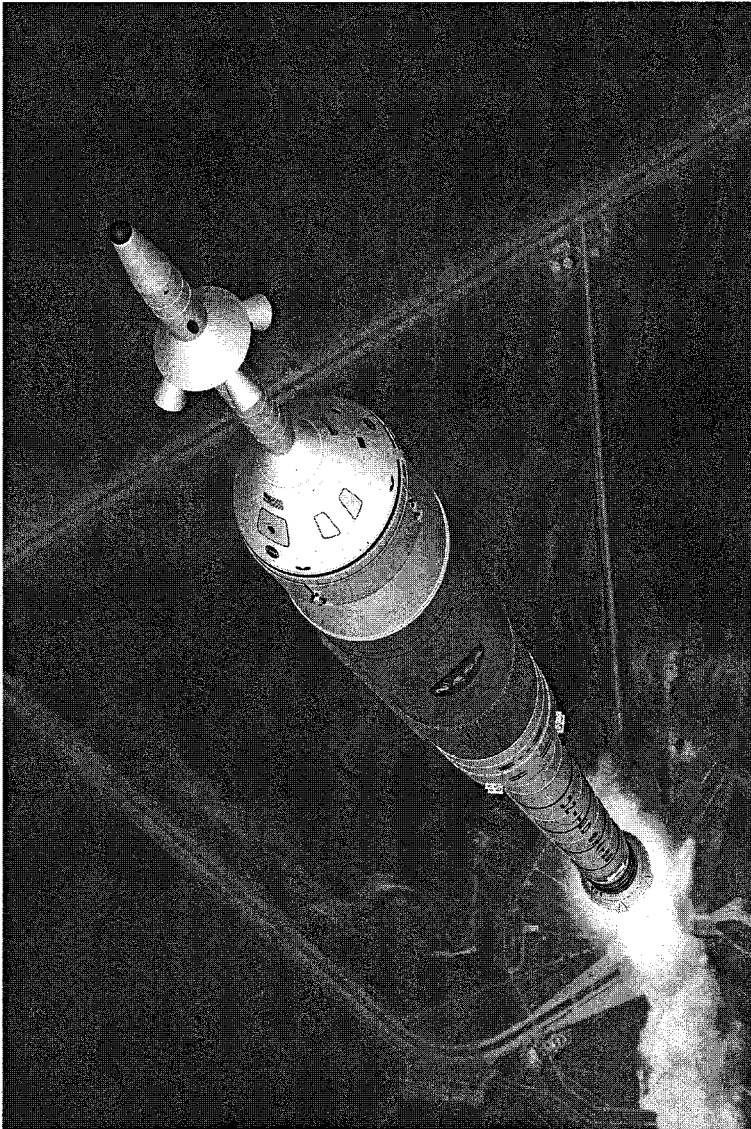

- ◆ Carries Crew Exploration Vehicle (CEV) to orbit to rendezvous with International Space Station or Ares V
- ◆ Ares I propulsion:
  - First Stage
  - 5-segment Reusable Solid Rocket Booster (RSRB)
  - Upper Stage
  - J-2X



# Exploration Launch Projects Architecture (cont'd)

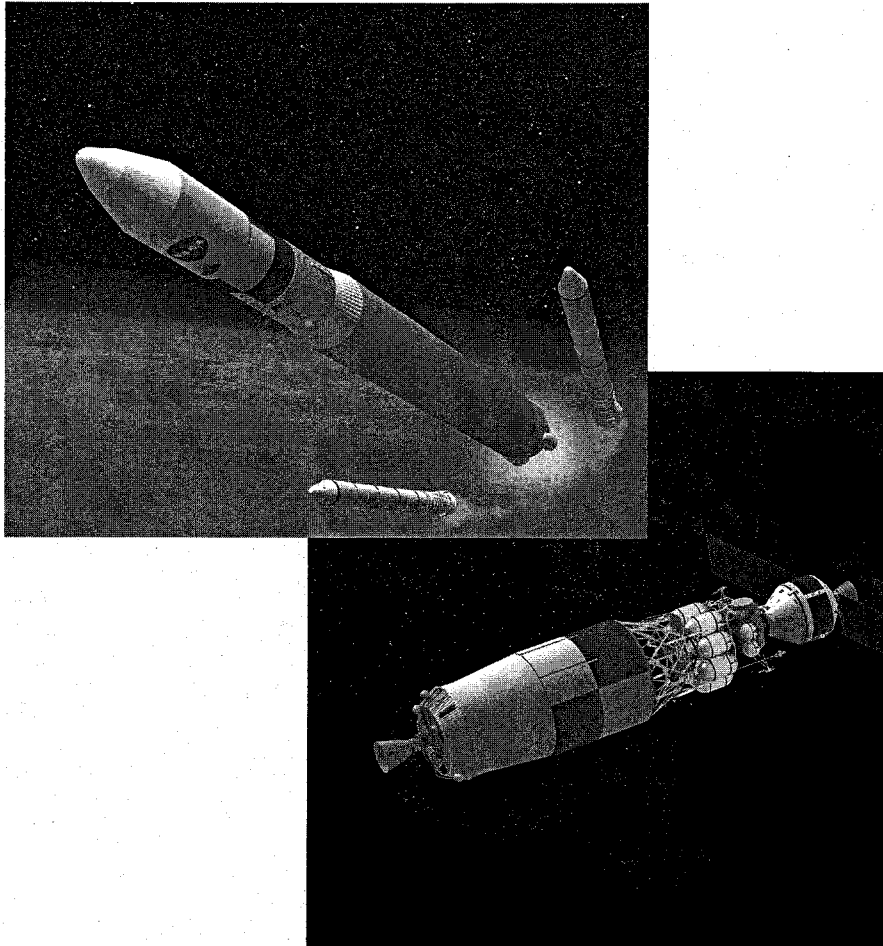

- ◆ **Ares V carries cargo to ISS or Lunar Surface Access Module (LSAM) and Earth Departure Stage to orbit**
- ◆ **Ares V Propulsion:**
  - Core Stage
  - 2 RSRBs
  - 5 RS-68
  - 33-foot (10 meter) diameter
  - Earth Departure Stage
  - J-2X for orbit circularization and Trans-lunar injection (TLI) burn
- ◆ **Common hardware and procedures with Ares I to reduce development and operations costs**



# Exploration Systems Architecture Study (ESAS)

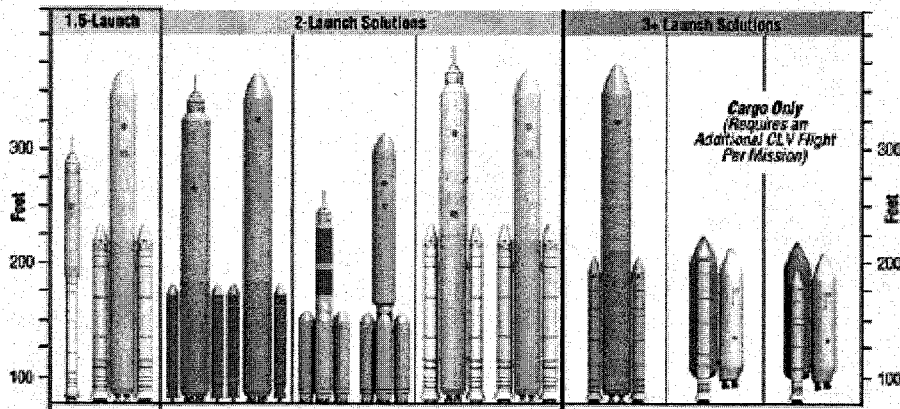

- ◆ Commissioned by Dr. Griffin in 2005
- ◆ Evaluated vehicles for ability to fulfill the Vision
- ◆ Recommended two-vehicle approach based on Shuttle and Saturn elements
  - Proven hardware
  - Leverage institutional knowledge and infrastructure
  - Experienced workforce
- ◆ CLV First Stage changed from 4-segment SRB to 5-segment SRB after Space Shuttle Main Engine (SSME) replaced by J-2X



# Ares I First Stage Progress

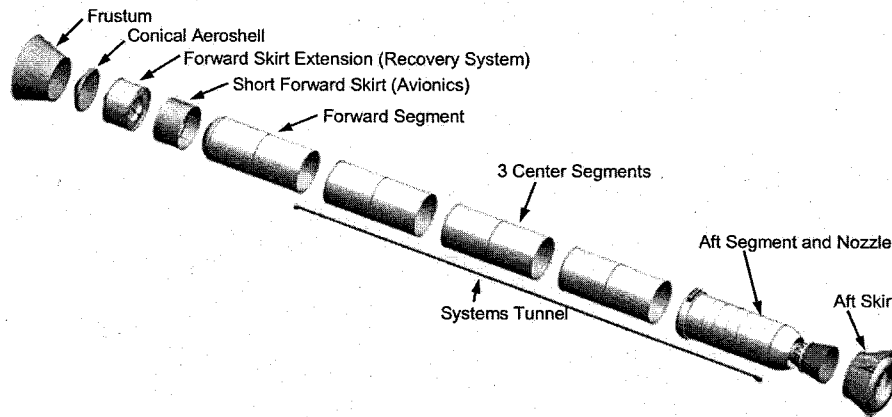

- ◆ Structures
- ◆ On-pad stabilization
- ◆ Motor and propellant
- ◆ Avionics and controls
- ◆ Pyro shock testing
- ◆ Reusability
- ◆ Staging and separation plane
- ◆ Ares I-X flight test



# Structures

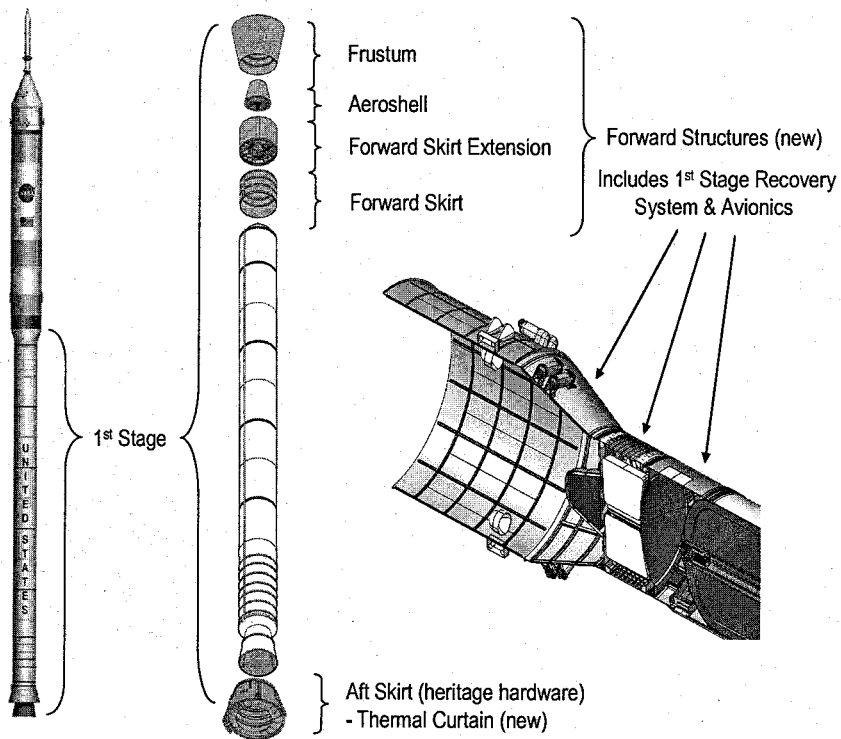

## ◆ A trade study resulted in the following design decisions for Ares I:

- Frustum – Composite
- Aeroshell – Composite
- Forward Skirt Extension – Aluminum
- Forward Skirt – Aluminum
- Trade study under way to determine need for access door in frustum



# On-pad Stabilization

---



- ◆ Trade study investigating need to stabilize Ares I on pad during roll-out and launch preparations

- Tie-down cables
- Mid-vehicle wrap-around
- Hold-down posts

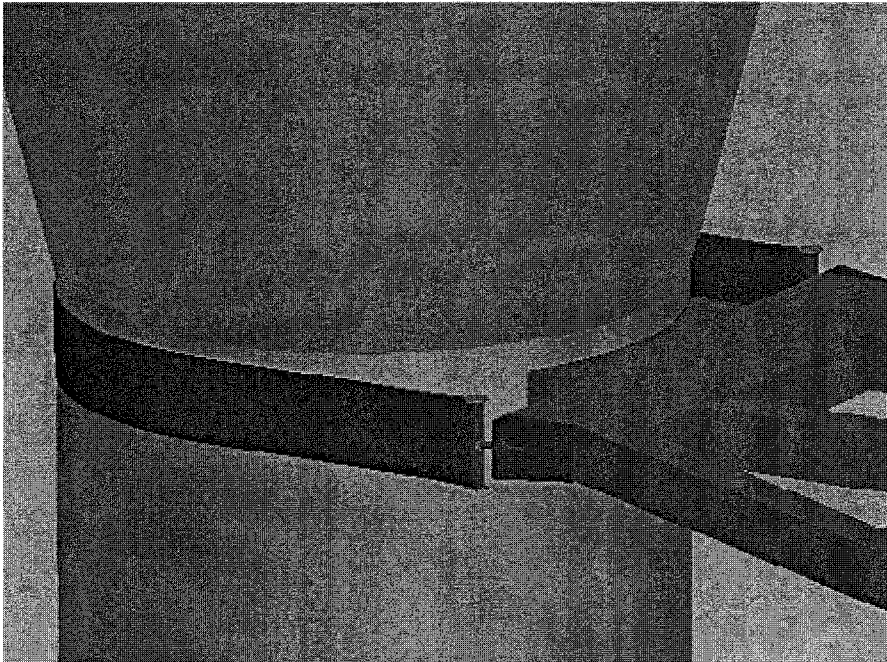





# Motor and Propellant

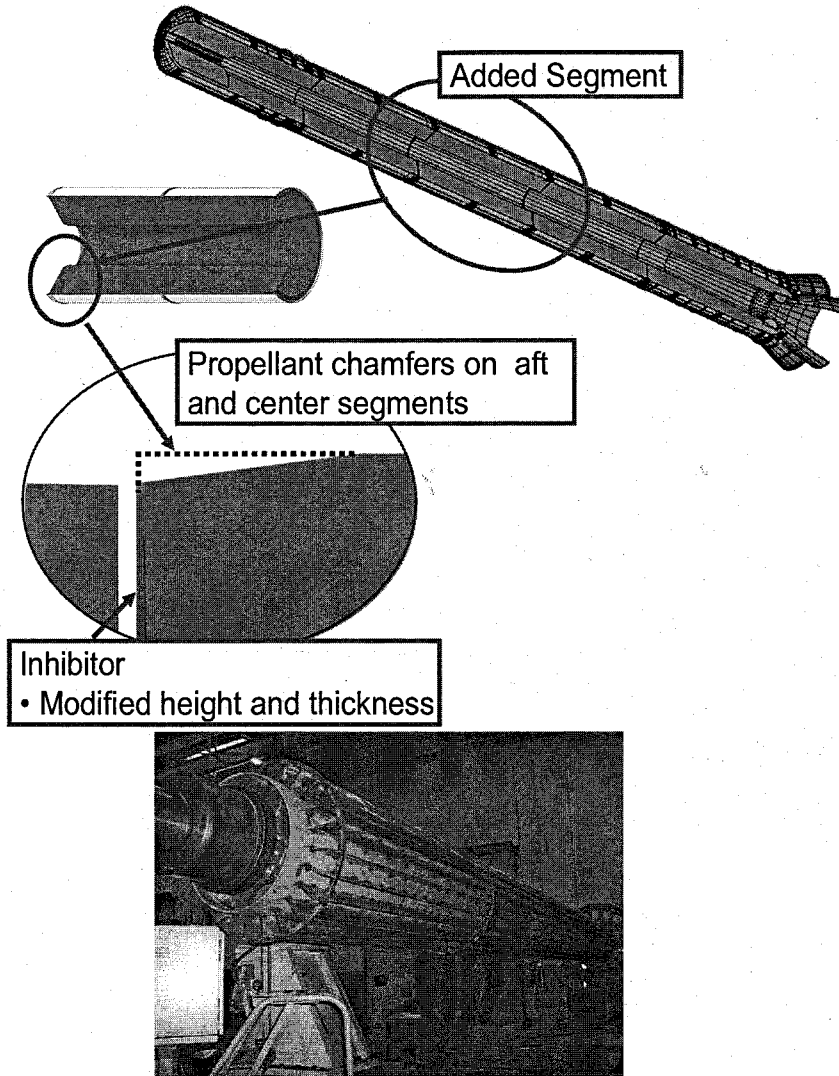

- ◆ Mandrel process simulators fabricated
- ◆ Modified propellant grain shape
- ◆ Chamfers prevent bore choking
- ◆ Vertical inhibitors added to ensure propellant burns evenly from axis
- ◆ Nozzle throat increased
- ◆ Aft exit cone extended
- ◆ Reformulated propellant to ensure ballistic thrust trace meets requirements



# Avionics and Pyro Shock Testing



- ◆ **Avionics & Controls**
- ◆ **Ares I-X Ascent Thrust Vector Controller (ATVC) tested with actual SRB hardware**
- ◆ **Hardware-in-the-loop testing begun at MSFC System Integration Laboratory (SIL)**
- ◆ **Continuing to better define and refine avionics requirements**
- ◆ **Pyro Shock Testing**
- ◆ **MSFC responsible for separation of Frustum/Interstage**
- ◆ **Using linear shaped charge (LSC) to separate joints and measure shock loads**
- ◆ **Shock loads could affect propellant in SRB nose cap cartridges**
- ◆ **Additional testing will use updated joints**



# Reusability Trade Study



## ◆ Trade study reviewing merits of continuing to reuse the SRBs vs. switching to expendable boosters

	Advantage(s)	Disadvantage(s)
<b>Reusable</b>	<ul style="list-style-type: none"><li>• Ability to evaluate hardware post-flight</li><li>• Increased reliability</li><li>• Hardware could be used until 2040</li></ul>	<ul style="list-style-type: none"><li>• Uncertain if booster can be recovered</li><li>• Heavier booster</li><li>• Higher obvious operating costs</li></ul>
<b>Expendable</b>	<ul style="list-style-type: none"><li>• Would not require parachutes or forward skirt extension</li><li>• Booster Tumble Motors (BTMs) or Thermal Protection Systems (TPS) not required</li><li>• Pyrotechnic events and hardware components reduced/removed as well</li><li>• Potential payload increase</li><li>• Reduced ground staff</li></ul>	<ul style="list-style-type: none"><li>• New design</li><li>• Unable to evaluate performance after launch</li><li>• Potential for less reliability and higher long-term costs</li><li>• More hardware would have to be purchased by 2018-202 time frame</li></ul>



# Staging and Separation Trade Study



## ◆ Examining separation sequence

- Concern: First Stage or Interstage hardware striking J-2X engine bell after separation
- Single-plane: entire First Stage separates at once at top of Interstage
- Dual-plane: First Stage separates at top of Frustum first, then top of Interstage

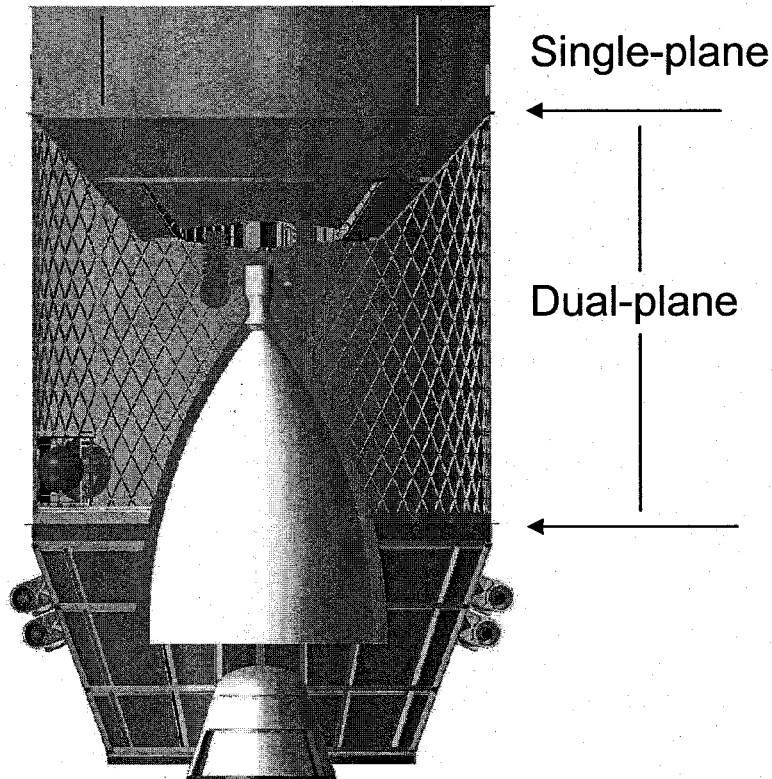

Single-plane

Dual-plane

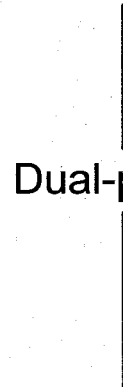
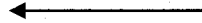



# Ares I-X Flight Test

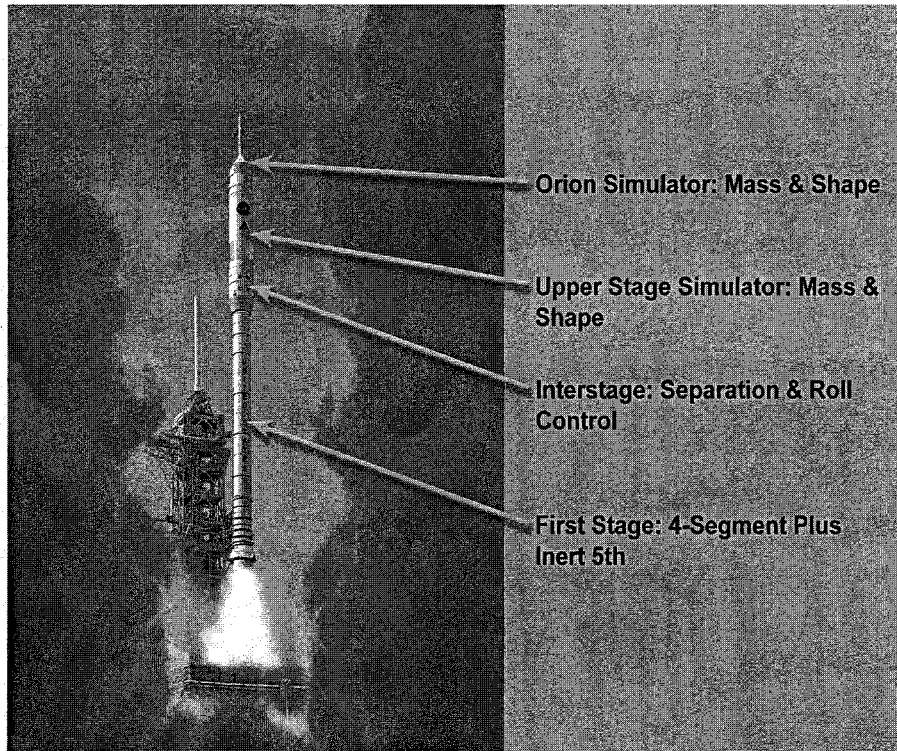

- ◆ **New forward structures on “critical path” for test flight**
- ◆ **Test will mimic Ares I flight trajectory and separation environments as much as possible**
- ◆ **Booster to be recovered**
  - Evaluate reentry environments
  - Retrieve data



# Forward Work

---



- ◆ **Drogue and main parachute tests scheduled to begin in September 2007**
- ◆ **Ares I Reviews:**
  - System Design Review (SDR) October 2007
  - Preliminary Design Review (PDR) April 2008
  - Critical Design Review (CDR) November 2010
- ◆ **First Development Motor (DM) is schedule to begin fabrication in late 2007**



# Summary

---



- ◆ **The Ares I and Ares I-X First Stage teams are actively pursuing the design and development of propulsion hardware for America's next generation of human-rated launch vehicles**
- ◆ **The Ares I-X test in April 2009 help validate the designs of the new forward structures**
- ◆ **Additional trade studies are under way to ensure that safe, reliable, and cost-effective decisions are made prior to the first crewed launch in 2013**
- ◆ **NASA's extensive experience with this Shuttle-legacy hardware, plus our efforts to improve upon it, will help ensure the continued human exploration of space for decades to come**



# Contact Information

---



**Tom Williams**

**[Thomas.J.Williams@nasa.gov](mailto:Thomas.J.Williams@nasa.gov)**

**256-544-7101**

**Questions?**