

## Vacuum Strength of Two Candidate Glasses for a Space Observatory

Timothy Andrew Manning<sup>1\*</sup>, Dennis S. Tucker<sup>2</sup>, Kenneth A. Herren<sup>2</sup> and Don A. Gregory<sup>1</sup>

1. *Department of Physics, University of Alabama in Huntsville, Huntsville, Alabama 35899*

2. *NASA George C. Marshall Space Flight Center, Huntsville, Alabama 35812*

The strengths of two candidate glass types for use in a space observatory were measured. Samples of ultra-low expansion glass (ULE) and borosilicate (Pyrex) were tested in air and in vacuum at room temperature (20°C) and in vacuum after being heated to 200°C. Both glasses tested in vacuum showed a significant increase in strength over those tested in air. However, there was no statistical difference between the strength of samples tested in vacuum at room temperature and those tested in vacuum after heating to 200°C.

Based in part on the thesis submitted by T.A. Manning for the M.S. degree in Physics, University of Alabama in Huntsville, Huntsville, AL, 2007.

\* Corresponding author email: mannint@uah.edu

## Introduction

A feasibility study was performed to determine if a large aperture (~150 m) space surveillance observatory can be manufactured and robotically assembled in space. It was determined that rather than constructing one large optic, a sparse array of one to two meter diameter optics would be more efficient and easier to construct. Due to the massive size of the observatory and the inherent delicacy of large optical elements, the most promising option is to ship raw glass material to a manufacturing device in space, which will produce the optics for later assembly. The vacuum strength testing of glass detailed below was performed to examine some possible effects of processing candidate glass types in space.

It is well established that subcritical crack growth in environments containing water vapor is caused by a stress corrosion reaction between water and the stressed glass [1-5]. It is thus necessary to understand the effect of vacuum on the strength of the candidate glasses. Wiederhorn [6] investigated the effects of a dry environment ( $N_2$  gas) on crack growth. He demonstrated an exponential dependence of crack velocity on applied load or stress intensity factor. Pukh *et al.* [7] reported crack growth in vacuum of selected glasses. Wiederhorn *et al.* [8] looked at crack growth in vacuum for four normal glasses and two glasses exhibiting anomalous elastic behavior. They found that that the normal glasses exhibited subcritical crack growth, however the two anomalous glasses did not. Wiederhorn *et al.* [9] also found that ultra-low expansion glass (ULE) did not undergo subcritical crack growth in a vacuum.

## Experimental Procedure

The samples tested in this study were Corning 7740 (Pyrex) and Corning 7971 (ULE) glasses. ULE was chosen as a candidate due to its near-zero thermal expansion coefficient.

Sample temperature was measured via thermocouples, and the vacuum level was determined by standard ion gauges. All samples were stored in a desiccation cabinet until they were brought into ambient laboratory conditions (1 atm, ~68% relative humidity) to be tested, and no sample was exposed to these ambient conditions for longer than ten minutes before it was either broken or placed in vacuum. Samples tested in air were removed from the desiccation cabinet one at a time as they were tested. Samples tested in vacuum at room temperature were held in high vacuum for 24 hours before testing. For the heated samples, a graphite resistance heater (6) was installed between the tray and test sample holder to heat each sample to 200°C for 24 hours in high vacuum. After the samples cooled to approximately 50°C, they were immediately moved to the sample holder and tested.

## Results

The failure stress of each sample was calculated using the equations presented by Kirstein and Wooley [11]. The results are summarized in Table I. Strength values are reported to two significant figures. Error analysis revealed that the maximum error in strength was 5% for the values presented in Table I. The strength of the Pyrex samples tested at room temperature was 54% higher in vacuum than in air. Heating the Pyrex samples to 200°C had no discernible effect on their strength compared to the unheated vacuum samples. The strength of the ULE samples tested at room temperature was 82% higher in vacuum than in air. Heating the ULE samples to 200°C resulted in an additional 10% increase over the strength of the unheated vacuum samples. However, this increase is well within the standard deviation. Weibull shape parameters are also included in the Table I summary. A two-sided t-test was used for both glass types to determine if there were significant differences of means between the samples tested in

vacuum at 20°C and those tested at 200°C at a 0.01 level of significance. The P-values, which denote the lowest level of significance at which the observed strength values are significant, were calculated to be 0.979 for the Pyrex samples and 0.051 for the ULE samples.

### **Discussion/Conclusions**

The data here agree well with the results of Wiederhorn *et al.* [8]. He found that subcritical flaw growth was absent in glasses exhibiting anomalous elastic behavior when crack growth was measured in vacuum. He also found that crack growth was decreased at temperatures near the glass transition temperature. This agrees with Suratwala and Steele's [12] observation that fused silica, which exhibits anomalous elastic behavior, showed a decrease in flaw growth as temperature increased. The temperatures in the present study were well below the glass transition regions for Pyrex and ULE, whose annealing temperatures (at which the glass viscosity is about  $10^{13}$  Poise) are 560°C and 1000°C respectively [13,14]. This may be the reason there was no observed statistical increase in strength when the glass samples were heated at 200°C.

There are two more experiments which should be performed. The first experiment would be to heat samples to the glass transition temperature in vacuum and then test their strengths. The second experiment would be to actually melt glass under vacuum, shape and cool it to form glass discs, and then measure the strength of those discs *in situ*. This latter experiment would be necessary to determine if a near theoretical strength can be obtained for these glasses due to the absence of water and other atmospheric contaminants. If this were indeed the case, then thinner elements could be used to produce the optics for the observatory.

1. T.C. Baker and F.W. Preston: The Effect of Water on the Strength of Glass. *J. Appl. Phys.*, **17**, 179-188 (1946).
2. C. Gurney and S. Pearson: The Effect of the Surrounding Atmosphere on the Delayed Fracture of Glass. *Proc. of the Phys. Soc.*, **62**, 469-476 (1949).
3. S.M. Wiederhorn and L.H. Bolz: Stress Corrosion and Static Fatigue of Glass. *J. Amer. Ceram. Soc.*, **53**, 543-548 (1970).
4. J.E. Ritter, Jr. and C.L. Sherburne: Dynamic and Static Fatigue of Silicate Glasses. *J. Amer. Ceram. Soc.*, **54**, 601-605 (1971).
5. R. Gy: Stress Corrosion of Silicate Glass: A Review. *J. Non-Cryst. Solids*, **316**, 1-11 (2003).
6. S.M. Wiederhorn: Influence of Water Vapor on Crack Propagation in Soda-Lime Glass. *J. Amer. Ceram. Soc.*, **50**, 407-414 (1967).
7. V.P. Pukh, S.A. Laterner and V.N. Ingai: Growth Kinetics of Cracks in Glass. *Sov. Phys.-Solid State*, **12**, 881-882 (1970).
8. S.M. Wiederhorn, H. Johnson, A.M. Diness and A.H. Heuer: Fracture of Glass in Vacuum. *J. Amer. Ceram. Soc.*, **57**, 336-341 (1974).
9. S.M. Wiederhorn, A.G. Evans, E.R. Fuller and H. Johnson: Application of Fracture Mechanics to Space-Shuttle Windows. *J. Amer. Ceram. Soc.*, **57**, 319-323 (1974).
10. ASTM F 394-78 (1996), Standard test method for biaxial flexural strength (modulus of rupture) of ceramic substrates. ASTM International.
11. A.F. Kirstein and R.M. Wooley: Symmetrical Bending of Thin Circular Elastic Plates on Equally Spaced Point Supports. *J. Res. Natl. Bur. Stand.*, **71C**, 1-10 (1967).

12. T.I. Suratwala and R.A. Steele: Anomalous temperature dependence of sub-critical crack growth in silica glass. *J. Non-Cryst. Solids*, **316**, 174-182, 2003.
13. Corning, Inc. 2007. Retrieved on January 24, 2007 from  
<[http://www.corning.com/Lifesciences/technical\\_information/techDocs/thermalprop.asp](http://www.corning.com/Lifesciences/technical_information/techDocs/thermalprop.asp)  
>.
14. Corning, Inc. 2007. Retrieved on January 24, 2007 from  
<[http://www.corning.com/specialtymaterials/materials-products/products\\_overview/ule.aspx](http://www.corning.com/specialtymaterials/materials-products/products_overview/ule.aspx)>.

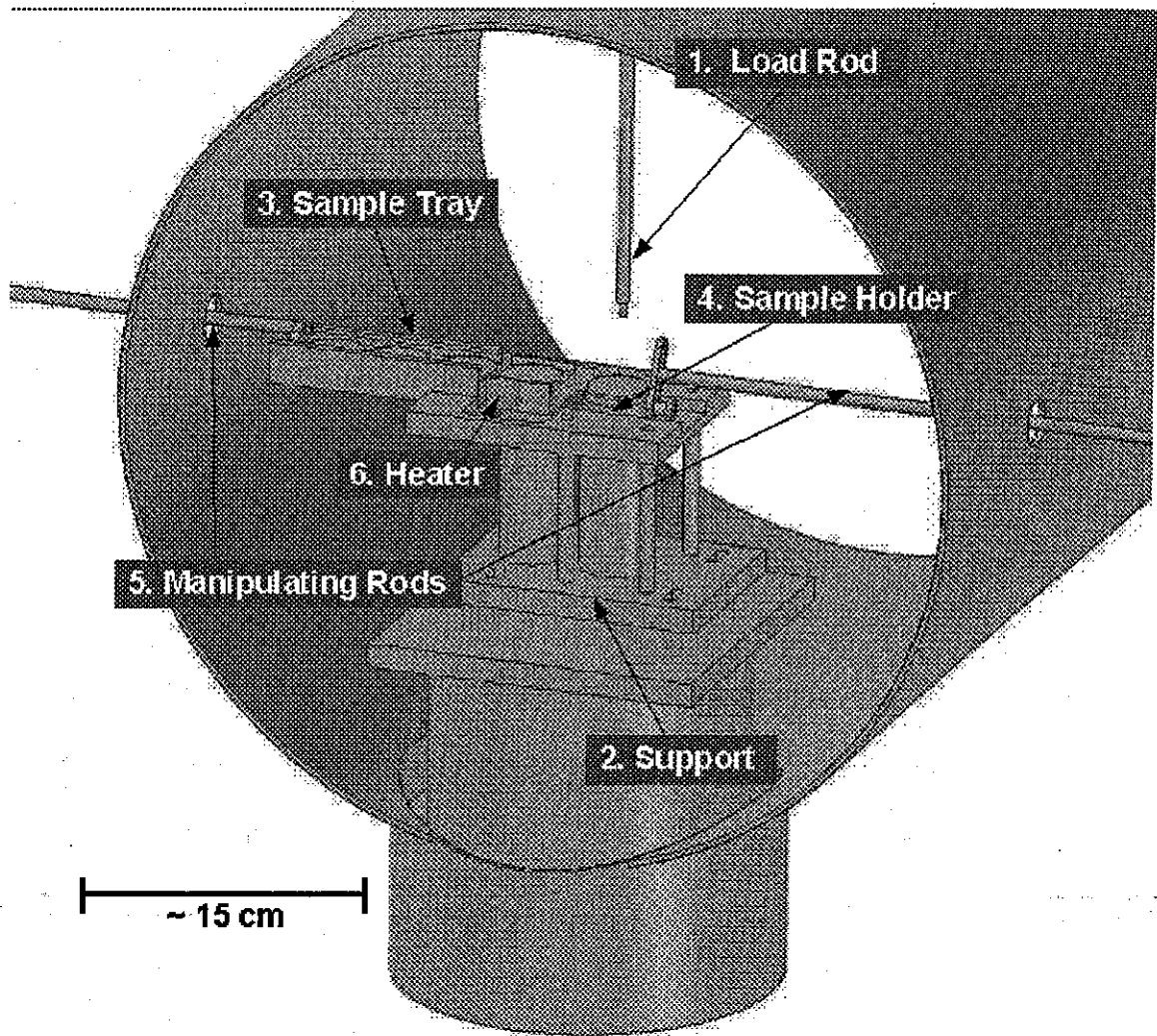

**Figure 1. Schematic of Glass Strength Testing Fixture in Vacuum Chamber**

**Table I. Measured Average Strength Values for Pyrex and ULE Glass Samples**

<b>Glass Type</b>	<b>Pressure (Pa)</b>	<b>Heating Temperature (°C)</b>	<b>Number of Samples</b>	<b>Average Strength (MPa)</b>	<b>Standard Deviation (MPa)</b>	<b>Weibull Shape Factor</b>
Pyrex	$10^5$ (1 atm)	20	14	110	12	9.96
	$\sim 10^{-4}$	20	10	170	26	7.86
	$\sim 10^{-4}$	200	12	170	20	8.81
ULE	$10^5$ (1 atm)	20	10	93	15	5.27
	$\sim 10^{-4}$	20	10	170	18	9.64
	$\sim 10^{-4}$	200	12	190	20	9.71