

NASA/CP—2006-214484

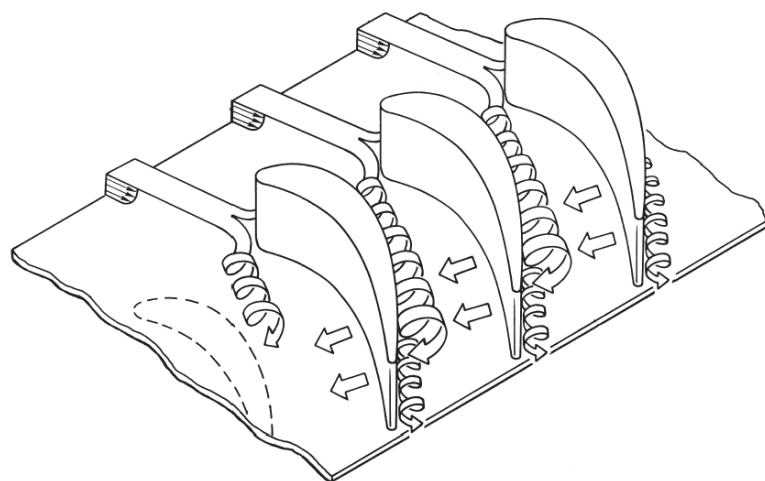

# Minnowbrook V 2006 Workshop on Unsteady Flows in Turbomachinery



## NASA STI Program . . . in Profile

Since its founding, NASA has been dedicated to the advancement of aeronautics and space science. The NASA Scientific and Technical Information (STI) program plays a key part in helping NASA maintain this important role.

The NASA STI Program operates under the auspices of the Agency Chief Information Officer. It collects, organizes, provides for archiving, and disseminates NASA's STI. The NASA STI program provides access to the NASA Aeronautics and Space Database and its public interface, the NASA Technical Reports Server, thus providing one of the largest collections of aeronautical and space science STI in the world. Results are published in both non-NASA channels and by NASA in the NASA STI Report Series, which includes the following report types:

- **TECHNICAL PUBLICATION.** Reports of completed research or a major significant phase of research that present the results of NASA programs and include extensive data or theoretical analysis. Includes compilations of significant scientific and technical data and information deemed to be of continuing reference value. NASA counterpart of peer-reviewed formal professional papers but has less stringent limitations on manuscript length and extent of graphic presentations.
- **TECHNICAL MEMORANDUM.** Scientific and technical findings that are preliminary or of specialized interest, e.g., quick release reports, working papers, and bibliographies that contain minimal annotation. Does not contain extensive analysis.
- **CONTRACTOR REPORT.** Scientific and technical findings by NASA-sponsored contractors and grantees.

- **CONFERENCE PUBLICATION.** Collected papers from scientific and technical conferences, symposia, seminars, or other meetings sponsored or cosponsored by NASA.
- **SPECIAL PUBLICATION.** Scientific, technical, or historical information from NASA programs, projects, and missions, often concerned with subjects having substantial public interest.
- **TECHNICAL TRANSLATION.** English-language translations of foreign scientific and technical material pertinent to NASA's mission.

Specialized services also include creating custom thesauri, building customized databases, organizing and publishing research results.

For more information about the NASA STI program, see the following:

- Access the NASA STI program home page at <http://www.sti.nasa.gov>
- E-mail your question via the Internet to [help@sti.nasa.gov](mailto:help@sti.nasa.gov)
- Fax your question to the NASA STI Help Desk at 301-621-0134
- Telephone the NASA STI Help Desk at 301-621-0390
- Write to:  
NASA STI Help Desk  
NASA Center for AeroSpace Information  
7121 Standard Drive  
Hanover, MD 21076-1320



# Minnowbrook V 2006 Workshop on Unsteady Flows in Turbomachinery

*John E. LaGriff*  
*Syracuse University, Syracuse, New York*

*David E. Ashpis*  
*Glenn Research Center, Cleveland, Ohio*

*Martin L.G. Oldfield*  
*University of Oxford, Oxford, United Kingdom*

*J. Paul Gostelow*  
*University of Leicester, Leicester, United Kingdom*

Proceedings of  
Minnowbrook V—2006 Workshop on Unsteady Flows in Turbomachinery  
sponsored by Syracuse University  
Blue Mountain Lake, New York  
August 20–23, 2006

National Aeronautics and  
Space Administration

Glenn Research Center  
Cleveland, Ohio 44135

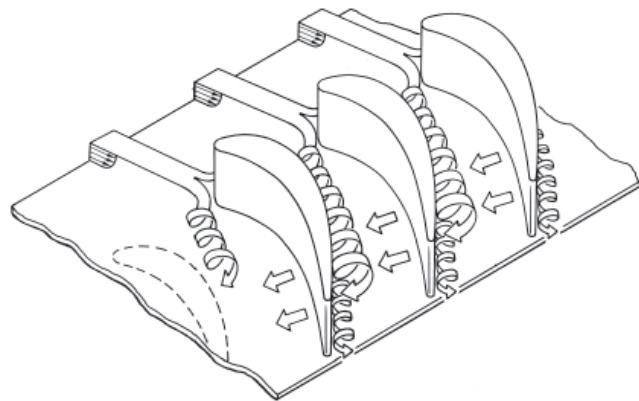

This report contains preliminary findings,  
subject to revision as analysis proceeds.

Contents were reproduced from author-provided  
presentation materials.

Trade names and trademarks are used in this report for identification  
only. Their usage does not constitute an official endorsement,  
either expressed or implied, by the National Aeronautics and  
Space Administration.

This work was sponsored by the Fundamental Aeronautics Program  
at the NASA Glenn Research Center.

*Level of Review:* This material has been technically reviewed by technical management.

Available from

NASA Center for Aerospace Information  
7115 Standard Drive  
Hanover, MD 21076-1320

National Technical Information Service  
5285 Port Royal Road  
Springfield, VA 22161

Available electronically at <http://gltrs.grc.nasa.gov>

## Acknowledgments

The workshop co-chairs would like to express their appreciation for financial support given to the workshop and to participants by the following organizations:

U.S. Air Force Office of Scientific Research  
(Rhett Jefferies, Grant AFOSR-FA 9550-06-1-0174)

NASA Glenn Research Center  
(David Ashpis and Lou Povinelli, Grant NNC06GA02G)

European Office of Aerospace Research and Development (EOARD)  
(Surya Surampudi, USAFOSR, Window on Science Program)

Asian Office of Aerospace Research and Development (AOARD)  
(Tae-Woo Park, USAFOSR, Window on Science Program)

### Local Organizing Support

Special praise is due to Linda Terramiggi and Kimberly Drumm-Underwood who devoted long hours and great care to the processing of the hundreds of details required for a successful workshop.

### Proceedings

Special thanks to Lorraine Feher, Editorial Assistant, Pat Webb, Coordinator, and Lisa Pukach, Desktop Publishing Assistant, of LTID Publishing Services at NASA Glenn, for their dedication in producing this volume.



## Preface

On August 20 to 23, 2006, over 40 attendees participated in a workshop entitled “Minnowbrook V—2006 Workshop on Unsteady Flows in Turbomachinery.”

Workshop co-chairs were

John E. LaGraff, Syracuse University, Syracuse, NY, U.S.A.

Martin Oldfield, Oxford University, Oxford, U.K.

J. Paul Gostelow, University of Leicester, Leicester, U.K.

The sessions were held at the Syracuse University Minnowbrook Conference Center in Blue Mountain Lake, New York, and followed the theme, venue, and format of four earlier workshops in 1993,<sup>1</sup> 1997,<sup>2</sup> 2000,<sup>3</sup> and 2003.<sup>4</sup> Earlier themes focused on various aspects of turbomachinery, aerodynamics, and heat transfer. The specific engineering application of improving design codes for turbomachinery was encouraged by the attendance of representatives from gas turbine manufacturers. The 2006 workshop again had a particularly strong representation from industry and the opening Industry Panel discussion helped set the tone of the workshop.

The format of the workshop was intentionally kept informal to encourage presentations, which could include a wide range of material spanning a level of formality from previously published work to work in progress or even future and proposed work. We did not want to inhibit presentation of relevant material for artificial reasons of normal publication restrictions. Written papers were not requested. Abstracts and copies of figures were the only written record of the workshop aside from specifically commissioned transcriptions of a workshop summary and the extensive working group reports, discussions, and summary that followed on the final morning of the workshop. The format of the workshop was also unusual in that nearly as much time was allowed for discussions as was allowed for the presentations. Groupings of three or four papers were followed by a large block of discussion time.

This volume contains abstracts and copies of the figures presented, organized according to the workshop sessions. The hard copy contains the keynote lecture, abstracts, and the transcripts of the plenary and summary sessions. The presentation slides are included on the accompanying CD. The post-workshop summary and the plenary-discussion transcript clearly highlight the need for continued research in the technologically important area of unsteady flows in turbomachines and made specific recommendations for future work. Finally, we were fortunate to have in attendance, Professor Roddam Narasimha for his fifth consecutive Minnowbrook workshop. It is difficult to quantify Professor Narasimha’s contribution, but it is safe to say that the workshop would not have been as successful without his participation. His broad experience with fluid dynamic fundamentals adds immeasurably to all discussions. His ability to listen to 25 separate papers and write a review of trends and gaps in our current knowledge of the field is truly remarkable. For this we are all indebted.

John E. LaGraff, Syracuse University  
David E. Ashpis, NASA Glenn Research Center  
Martin L.G. Oldfield, Oxford University  
J. Paul Gostelow, University of Leicester

---

<sup>1</sup>NASA/CP—2007-214667, J.E. LaGraff, editor (also Syracuse University report).

<sup>2</sup>NASA/CP—1998-206958, J.E. LaGraff and D.E. Ashpis, editors.

<sup>3</sup>NASA/CP—2001-210888, J.E. LaGraff and D.E. Ashpis, editors.

<sup>4</sup>NASA/TM—2004-212913, J.E. LaGraff and D.E. Ashpis, editors.





# Table of Contents

Presenters' names in boldface

## Keynote Speaker

**Reza S. Abhari**, ETH Zurich  
*Unsteady Fluid Dynamics of Turbines: A Perspective on Possible Directions to Improve Future Engine Designs* ..... 3

## Session 1—Industry Panel

**Simon Gallimore**, Rolls-Royce  
**Jochen Gier**, MTU Aero Engines  
**Om Sharma**, Pratt & Whitney  
**Allan Van Dewart**, General Electric

## Session 2—Unsteady Flows and Wakes

M. Opoka, R. Thomas, and **H.P. Hodson**, University of Cambridge  
*The Influence of Wakes, Freestream Turbulence, and Downstream Blade Rows on the Transition Mechanisms in LP Turbines* ..... 27

**G.J. Walker** and A.D. Henderson, University of Tasmania; and J.D. Hughes, Rolls-Royce  
*Unsteady Wake-Induced Transition on Axial Compressor Blades—Calming and Leading Edge Interaction Effects* ..... 29

Yi Chih Chow, Francesco Soranna, Oguz Uzol, and **Joseph Katz**, The Johns Hopkins University  
*Complex Wake-Blade and Wake-Wake Interactions in Multistage Turbomachines* ..... 31

**Thomas J. Praisner** and Daniel R. Sabatino, Pratt & Whitney United Technologies; and Charles R. Smith, Lehigh University  
*The Dynamics of the Horseshoe Vortex and Associated Endwall Heat Transfer* ..... 32

## Session 3—Blade Cooling and Heat Transfer

**Martin Oldfield**, University of Oxford  
*Unsteady Turbine Flows and Heat Fluxes at Oxford, Then and Now* ..... 34

Brian M. Holley and **Lee S. Langston**, University of Connecticut  
*Comparison of Turbine Cascade Measurements of Skin Friction, Limiting Streamline Direction, and Heat Transfer* ..... 36

C.W. Haldeman, R.M. Mathison, **M.G. Dunn**, S. Southworth, and J.W. Harral, The Ohio State University; and G. Heitland, Honeywell Aerospace  
*Aerodynamic and Heat Flux Measurements in a Fully Cooled HPT* ..... 38

<b>Karen A. Thole</b> , The Pennsylvania State University <i>Effects of Inlet Flow Conditions on Endwall Flows in Turbine Vane Passages</i> .....	39
--	----

**Session 4—Separation Bubbles and Spots**

<b>J. Hourmouziadis</b> and G. Hofmann, Berlin University of Technology <i>Response of Separation Bubble to Velocity and Turbulence Wakes</i> .....	41
--	----

<b>Jeffrey Bons</b> , Brigham Young University <i>Unsteady Transition and Separation in an LPT Cascade</i> .....	43
---	----

<b>J.P. Gostelow</b> , R.L. Thomas, and D. Adebayo, University of Leicester <i>Wake Interactions and the Pervasive Influence of the Calmed Region</i> .....	45
--	----

<b>Metin I. Yaras</b> , Carleton University <i>Effects of Freestream Turbulence and Streamwise Pressure Gradient on the Substructures of Turbulent Spots</i> .....	46
---	----

P.R. Viswanath and R. Mukund, National Aerospace Laboratories; <b>Roddam Narasimha</b> , Jawaharlal Nehru Centre for Advanced Scientific Research; A. Prabhu, Indian Institute of Science; and J.D. Crouch, Boeing Commercial Airplanes <i>Transitions on Swept Leading Edges</i> .....	48
--	----

**Session 5—Flow Control and Roughness**

<b>Vassilis Theofilis</b> , Universidad Politécnica de Madrid; and Nadir Abdessemed and Spencer J. Sherwin, Imperial College London <i>Linear Instability of the Flow Past a Low Pressure Turbine Blade</i> .....	50
--	----

<b>H.F. Fasel</b> , W. Balzer, and A. Gross, University of Arizona <i>Numerical Investigation of Active Control for Low-Pressure Turbine Blades</i> .....	51
--	----

Travis C. Douville, Julia Stephens, Daniel K. Van Ness, <b>Thomas C. Corke</b> , and Scott C. Morris, University of Notre Dame <i>Turbine Blade Tip Clearance Flow Control Using Plasma Actuators</i> .....	53
--	----

<b>Edward B. White</b> , Robert S. Downs III, and Nicholas A. Denissen, Case Western Reserve University <i>Transient Disturbances Generated by Quasi-Random Surface Roughness</i> .....	55
--	----

**Session 6—Axial Compressors and Fans**

Damian M. Vogt and <b>Torsten H. Fransson</b> , KTH; and Hans E. Mårtensson, Volvo Aero <i>Experimental and Numerical Study of Unsteady Aerodynamics in an Oscillating LPT Cascade</i> .....	57
---	----

<b>Joerg R. Seume</b> , Leibniz Universität Hannover <i>Acoustic Resonance in a High-Speed Axial Compressor</i> .....	59
<b>Steven E. Gorrell</b> , David Car, and Steven L. Puterbaugh, Air Force Research Laboratory <i>Blade Row Interaction Research at the Air Force Research Laboratory Propulsion Directorate</i> .....	60
<b>W. Solomon</b> , H-W. Shin, and D. Wilkin, General Electric Aviation <i>Unsteady Flow Downstream of a Transonic Rotor</i> .....	62

**Session 7—Computational Work**

Tamer A. Zaki, Imperial College; <b>Paul A. Durbin</b> , Iowa State University; and Jan Wissink and John Rodi, University of Karlsruhe <i>DNS of Transition in a Linear Compressor Cascade</i> .....	63
<b>W. Rodi</b> and J.G. Wissink, University of Karlsruhe <i>DNS of Flow and Heat Transfer in Turbine Cascades Under the Influence of Free Stream Disturbances</i> .....	64
<b>J.P. Clark</b> and P.J. Koch, Air Force Research Laboratory <i>Designing Turbine Airfoils to Answer Research Questions in Unsteady Aerodynamics</i> .....	66
<b>K. Engel</b> , MTU Aero Engines; and Dirk Nuernberger and Edmund Kuegeler, DLR <i>Unsteady CFD Simulations for IPC Off-Design Operating Conditions</i> .....	68

**Session 8—Workshop Plenary Session**

**Report of Ad Hoc Working Groups**

<b>Mike Dunn</b> , The Ohio State University <i>Heat Transfer and Film Cooling Group</i> .....	71
<b>Bill Solomon</b> , General Electric Aviation <i>Fans and Compressors Group</i> .....	74
<b>Tom Corke</b> , University of Notre Dame <i>Flow Control Group</i> .....	77
<b>Paul Durbin</b> , Iowa State University <i>Computational Methods and Transition Group</i> .....	80

**Industry Panel Reports**

**Simon Gallimore, Rolls-Royce**  
*Report of Industry Panel Group* ..... 82

**Om Sharma, Pratt & Whitney**  
*Impact of Surface Roughness in Axial Flow Gas Turbine Engines* ..... 87

**Transcripts**

**Paul Gostelow, University of Leicester**  
*Final Plenary Session Transcript* ..... 91

**Roddam Narasimha, Indian Institute of Science**  
*Workshop Summary Transcript* ..... 103

**List of Participants**..... 111

# **Keynote Presentation**



**Keynote Presentation**

**Unsteady Fluid Dynamics of Turbines:**

**Perspective on Possible Directions to  
Improve Future Engine Designs**

**Reza S. Abhari  
ETH Zurich**

**Minnowbrook  
August 20th, 2006**

**Contents:**

- ◆ **Unsteady Flows in Turbomachines**
- ◆ **Focus on:**
  - **Aerodynamic Performance**
  - **Heat Transfer and Cooling**
  - **Forced Response**
- ◆ **Proposal for Future Directions**

**Acknowledgements: To many students and colleagues**  
**Special Thanks to Thomas Behr, Andre Burdet,**  
**Albert Kammerer, Thomas Mokulys and Luca Porreca**

## Flow Unsteadiness in Turbomachines

- ◆ In the absence of non-conservative body forces, the total enthalpy of an adiabatic inviscid flow can change through a time varying pressure field

$$\rho \frac{Dh_T}{Dt} = \frac{\partial p}{\partial t}$$

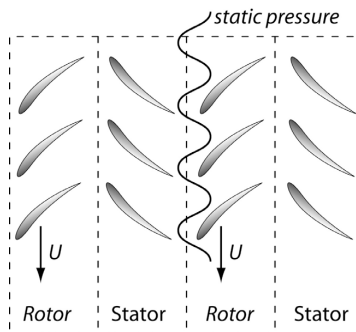

## Turbomachines: Periodic and Turbulent Unsteady Flow Structures

- ◆ Traditionally handled through triple decomposition

$$T = \bar{T} + \tilde{T} + T'$$

$$P = \bar{P} + \tilde{P} + P'$$

$$U = \bar{U} + \tilde{U} + U'$$

$$V = \bar{V} + \tilde{V} + V'$$

⋮

Turbulent Reynolds Stress terms

$$\overline{U'V'}, \overline{U'W'}, \overline{V'W'}, \overline{U'T'}, \dots$$

Periodic Reynolds Stress

$$\overline{\tilde{U}\tilde{V}}, \overline{\tilde{U}\tilde{W}}, \overline{\tilde{V}\tilde{W}}, \overline{\tilde{U}\tilde{T}}, \dots$$

- ◆ Large amount of work in the past two decades has focused on assessing and modeling the influence of Periodic and Tu Reynolds stress terms on design of turbomachines
- ◆ Selected insight for turbines



## Unsteady Flows in Turbomachines

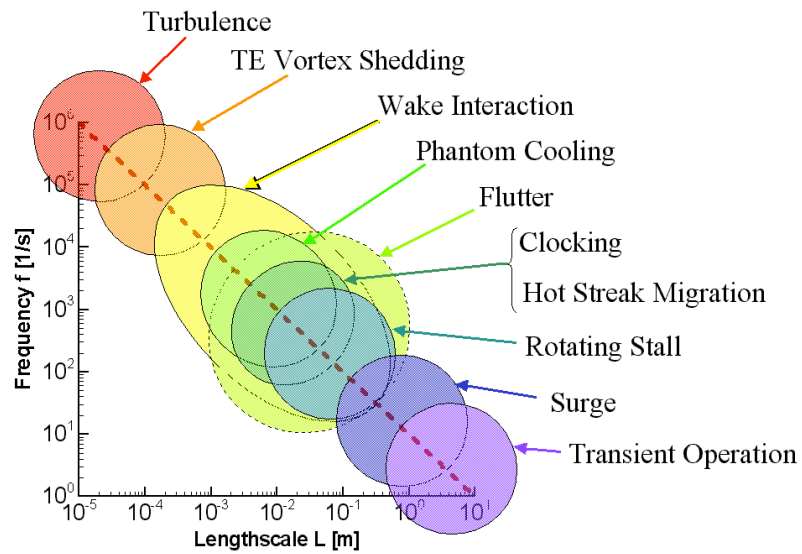

- ◆ **Flow structures with 5 to 6 orders of magnitudes variations in length and time scales**

## Aerodynamic Performance

## Impact on Direct Operational Cost

- 17% weight reduction → 1% DOC
- 17% weight reduction → 3.7% SFC
- 1% efficiency change in LP turbine → 0.96% SFC

D. Wisler – GE, USA- 1998

## Aerodynamic - Sources of unsteadiness

### Periodic

- **Potential Interaction**
  - Related to velocity and pressure field of adjacent blade rows
  - Affected by axial gap and Mach numbers
- **Vortical and entropy wakes**
  - Large-scale flow structures (streamwise vortices)
  - Shed wakes
- **Shock wave interaction**
  - Shock systems can extend upstream and downstream and appear as unsteady discontinuities
- **Hot streaks**
  - Non-uniform temperature distribution at the combustor outlet
  - Produces preferred heating at the pressure side of the first stage rotor with respect to suction side

### Non-deterministic

- **Mixing**
  - Two flows (Tip leakage, shroud leakage, coolant injection)
  - Shear layers (Wake, secondary vortices)
- **Turbulence**
  - Freestream
  - Boundary layer (endwall, blade surface)

## Aerodynamic Loss in a single Stage Axial HPT- Comparison of unsteady and steady simulations

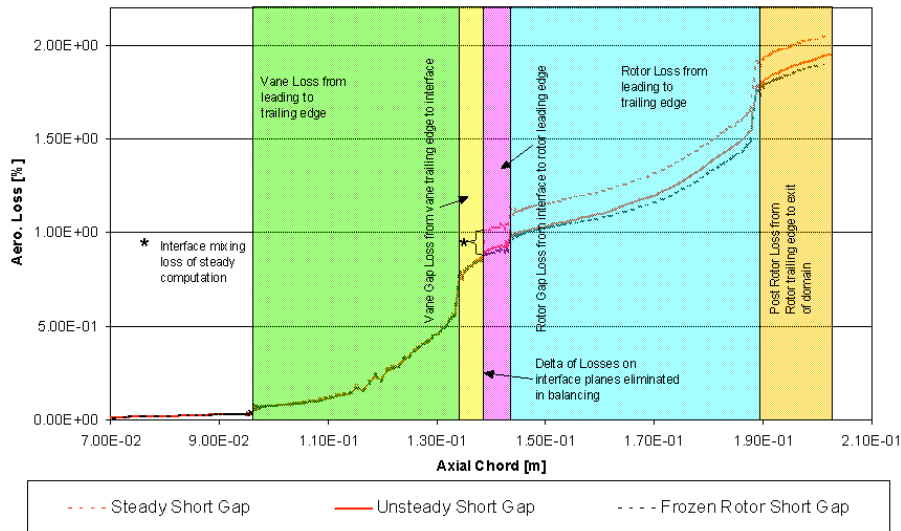

In this case, influence of unsteadiness is less than 0.2% on efficiency

## Aerodynamic - unsteady contribution to loss

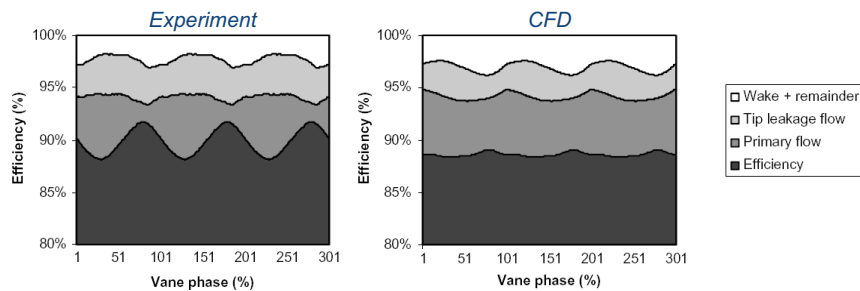

Breakdown of efficiency variation with vane position.

- Experimental approach to measure unsteady entropy in turbine flow
- Unsteady change in stage efficiency as the rotor moves relative to the upstream vane under-predicted by CFD (Experiment: 1.2%, CFD: 0.2%)
- Efficiency level is slightly under-predicted (Experiment 1.2% higher than CFD)
- “Interaction effects have been shown to have a significant impact on the stage efficiency and must be considered carefully when attempting to improve the efficiency of blade designs”

S.J. Payne a, R.W. Ainsworth, R.J. Miller, R.W. Moss, N.W. Harvey, **Unsteady loss in a high pressure turbine stage: Interaction effects**, International Journal of Heat and Fluid Flow 26 (2005) 695–708

## Improving Performance- Stator & Rotor Clocking

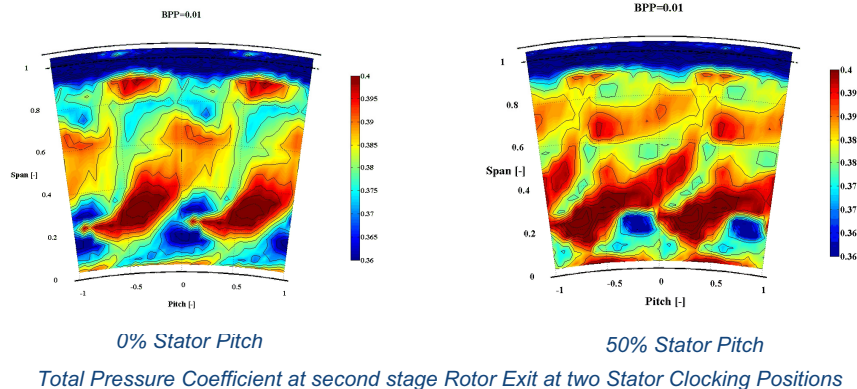

- Highly 3D flow field with strong interaction of wakes and vortices
- Unsteady flow field is dominated by rotor flow features
- Interaction region of passage vortex of upstream stator with rotor passage vortex shifts with stator clocking position
- Opportunity to improve stage efficiency due to clocking has been within +/- 0.3%, Based on ETH exp & comp experience of a number of turbines

T. Behr, et al. Multistage Aspects and Unsteady Flow Effects of Stator and Rotor Clocking in an Axial Turbine with Low Aspect Ratio Blading, ASME J. Turbomach., 128, pp. 11-21.

## Aerodynamic - Effect of Hot Streaks Mixing not Accurately Computed

- **Kerrebrock-Mikolajczak**
  - Velocity of hot streaks scales with temperature
- **Hot streaks**
  - Positive incidence
  - Cause heating of the rotor pressure side
  - Spread radially on the rotor pressure side (1)
- **Cold streaks**
  - Negative incidence
  - Impinge on rotor suction side (1)
  - Getting squeezed at midspan due to rotor secondary flows (1)

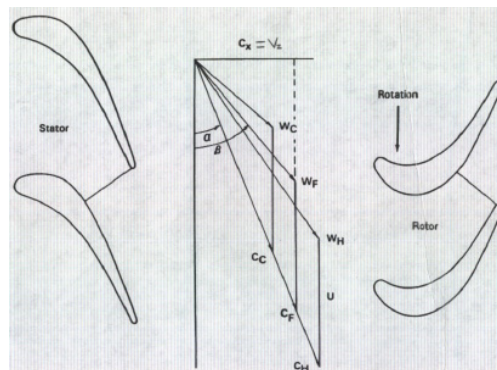

Velocity triangles, Kerrebrock-Mikolajczak effect

(1) Butler, T. L., Sharma, O. P., Joslyn, H. D., and Dring, R. P., "Redistribution of an Inlet Temperature Distortion in an Axial Flow Turbine Stage", Journal of Propulsion and Power, Vol. 5, No. 1, 1989, pp. 64-71.

## Trailing Edge Vortex shedding

- Characteristic length/freq scales with TE
- Produces higher order terms for Vib
- Possible Radial distribution of losses
- Impacts “steady” CFD computation with fine grids
- Limiting factor in getting grid independent CFD solutions

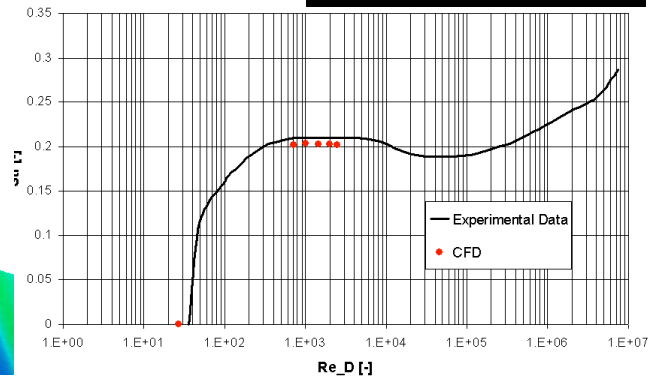
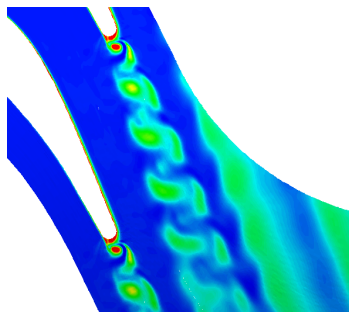
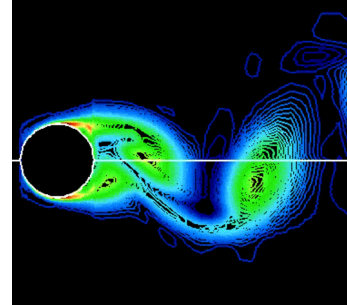

## Aerodynamic - Low Re No. transition

- **Main focus on LP turbine blade design**
  - **Concept** → BL transition is affected through periodic unsteady wake perturbations

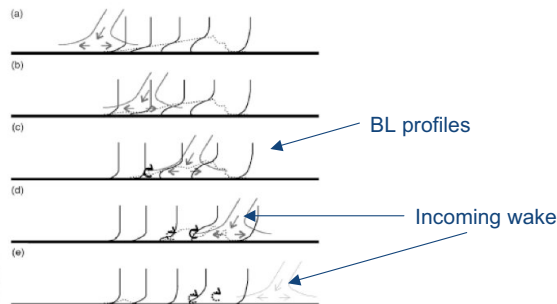

Stieger and Hodson – Cambridge Whittle Lab UK,2004

- **Benefit** → Increase blade loading → reduce blade count
  - Reduce weight
  - Reduce cost of the LP turbine section

## Major Role of Unsteadiness in Low Re Applications

- Pressure losses significantly reduced in unsteady environment

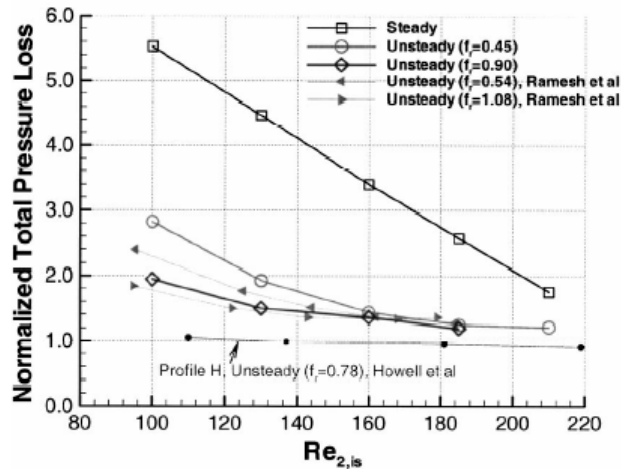

X. Zhang, M. Vera, H. Hodson, N. Harvey – Cambridge Whittle Lab UK, 2006

## Unsteadiness Has a Major Impact on Performance of Low Reynolds Number Turbines

- ♦ Opportunities also exist in non-traditional applications (distributed power, ultra-small GT's, etc..)
- ♦ HP Turbines operating at low Re No. ( $<1E5$ ) exhibit significant contribution of unsteady terms to the stage loss generation

-ETH Zurich, high work axial turbine.  
-Rotor blade height 3 mm

- Ref: Mokuly's PhD thesis (2006)

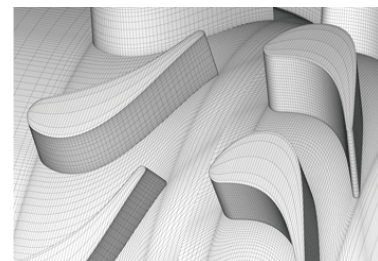

## Non-Deterministic Unsteady Flows

- Turbomachinery design often uses models validated in very simple flow test cases
- Turbulence measurements in turbomachine are few
  - Xiao and Lakshminarayana - Penn State University, 2001 -LDV measurements in an axial turbine rotor
  - Ristic et al. - Penn State University,1998 - Assessment of anisotropy
  - Chaluvadi et al. - Cambridge University, 2003 - Hot Wire measurements in an axial turbine
  - Binder et al. – MTU, 1999 - Hotwire measurements in a low pressure turbine
  - Porreca et al. – ETH Zurich, 2005

## Turbulence Modeling

- Current CFD tools use isotropic turbulence assumption

$$u' \approx v' \approx w'$$

- In turbomachinery environment turbulence is not necessarily isotropic
  - Measurement of anisotropy

$$DA = \frac{\overline{u'^2}}{\frac{1}{2}(\overline{v'^2} + \overline{w'^2})}$$

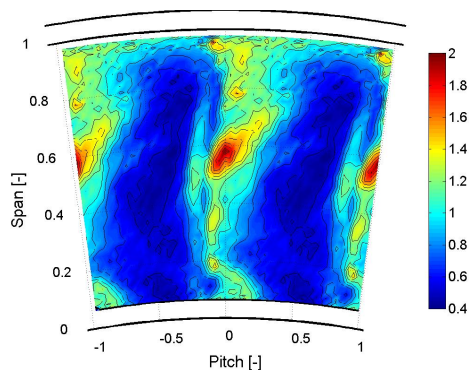

Porreca et al. – ETH Zurich, 2005

## Advanced High response Instrumentation Has been A Major Tool to Improve Understanding



2-Sensor Fast Response Aerodynamic Probe (FRAP)

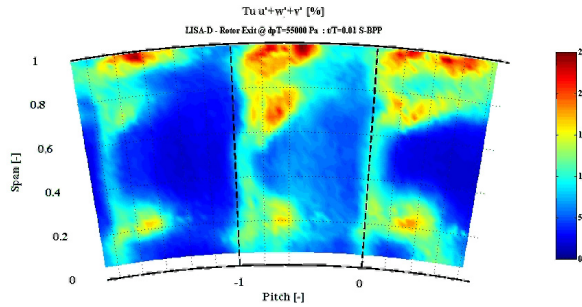

Turbulence Intensity in Rotor Exit Flow Field of an Unshrouded High-Work Turbine (Rotor relative frame)

- Rel circumf. distance of rotor vortices varies by  $\pm 20\%$  of a rotor pitch
- Rotor vortices are modulated by second stator leading edge and show variation in size and relative position to rotor trailing edge
- Clear coupling between non-deterministic turbulent characteristics and periodic flow structures

T. Behr, A. I. Kalfas, R. S. Abhari, Multistage Aspects and Unsteady Flow Effects of Stator and Rotor Clocking in an Axial Turbine with Low Aspect Ratio Blading, ASME J. Turbomach., 128, pp. 11-21

P. Porreca, A. I. Kalfas, R. S. Abhari, Turbulence Measurements und Analysis in a Multistage Axial Turbine, ISABE 2005.

## Aerodynamic - cavity / leakage flow

- Flow in the labyrinth seal and in the cavity is often neglected in blade design
- Recent studies on cavity flow – influence on performances
  - Rosic et al. Cambridge Whittle Lab, 2006 – effect of leakage flow on aero performances
  - Porreca et al. ETH Zurich, 2005 – effect of shroud geometry on aero performances

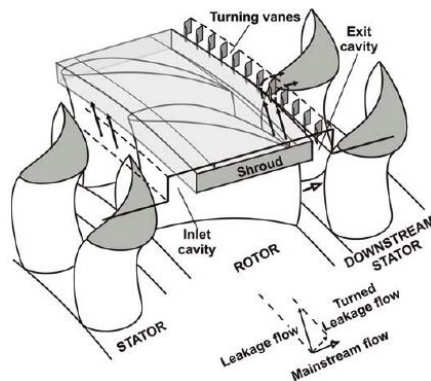



## Aerodynamic of cavity / leakage flow

- **Cavity flow models and unsteady CFD increase prediction accuracy**

- Losses in the cavity separation<sup>1</sup>
  - Mixing losses up to 50% of total cavity losses
  - „by pass“ and „step“ losses about 20% each
  - Losses due to negative incidence on subsequent stator blade negligible

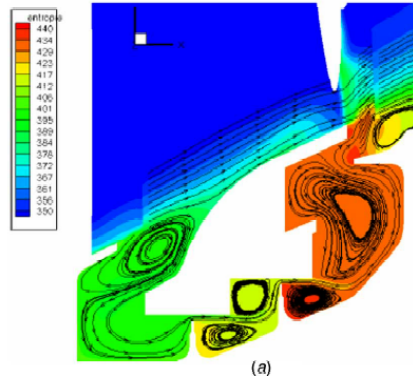

<sup>1</sup>Gier et al. MTU, 2005

## Aerodynamic - Cavity / Leakage Flow

- **Unsteady flow field in the labyrinth seal**

- Can dominate the secondary flow formation and losses<sup>1, 3</sup>
- Unsteady toroidal vortex in the tip cavity driven by the stator/rotor potential field<sup>2</sup>

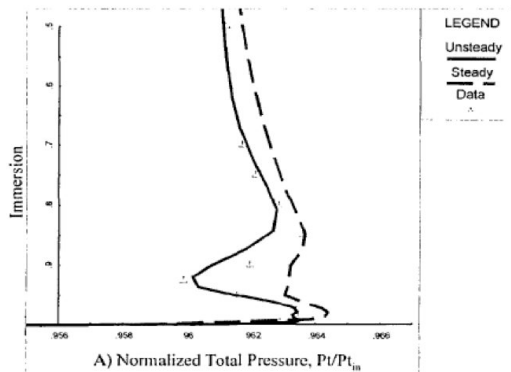

<sup>1</sup>Hunter and Manwaring – GE USA, 2000

<sup>3</sup>Schlienger, PhD thesis 2004

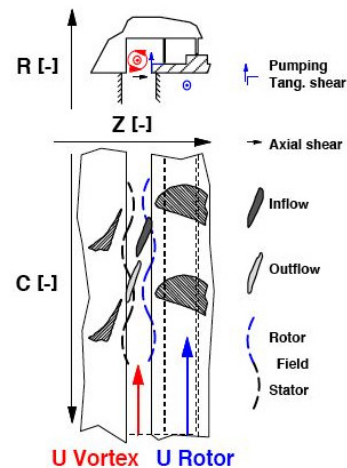

<sup>2</sup>Pfau et al ETH Zurich, 2005

# Cavity-Driven Unsteady Flow has a Significant Impact on Performance of Shrouded Turbines

- Losses in the tip cavity
  - Overall labyrinth losses ~ 1.6% stage efficiency
  - Toroidal vortex – minor contribution

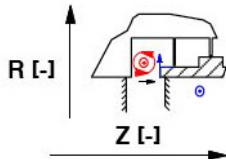

Unsteady circumferential vortex stretching component in the tip cavity

- Pfau et al., 2005
- Rusch et al., 2004

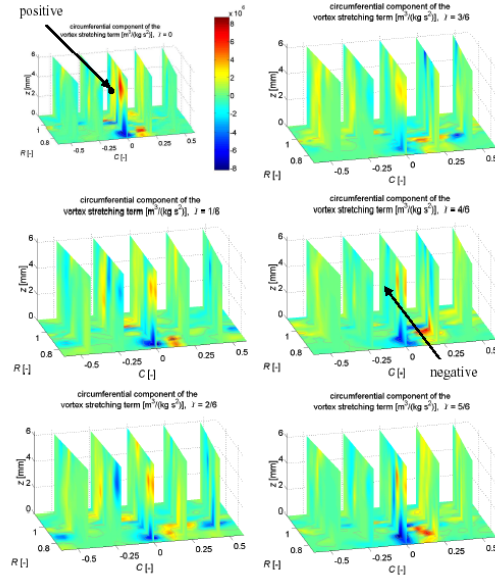

## Heat Transfer and Cooling

## Heat transfer - high pressure turbine

### Design goal tradeoff

**Maximum gas temperature** ⇒ higher efficiency and lower NO<sub>x</sub> emission

**Minimum material heat load** ⇒ lower risk and increased lifetime

### Design historically based on integrated heat load in isolated blade

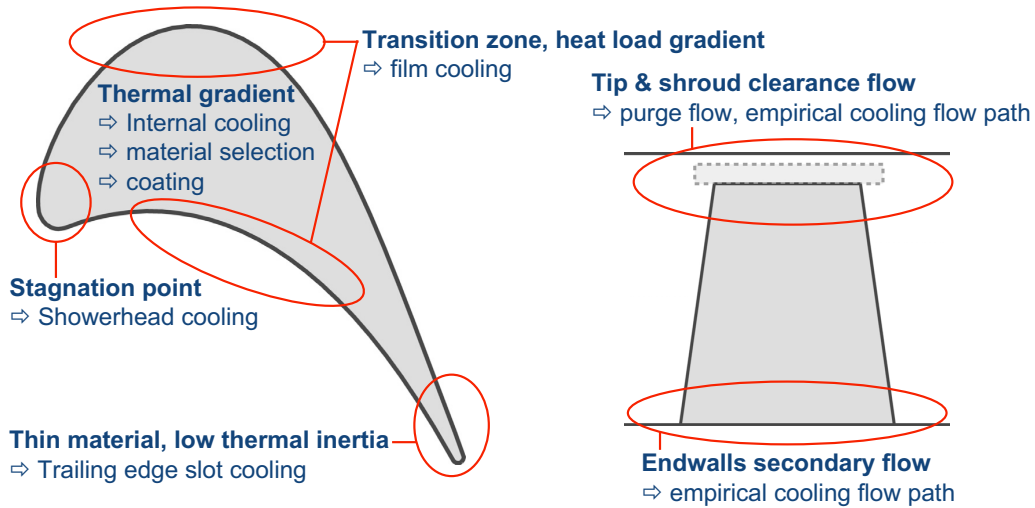

## Heat transfer - unsteady processes

### Periodic ⇒ Component level

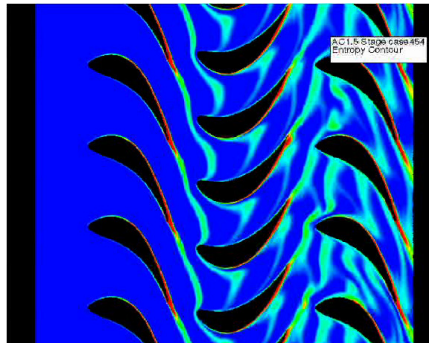

Mokuly's (2003) ETH-Zürich

### Statistical ⇒ System level

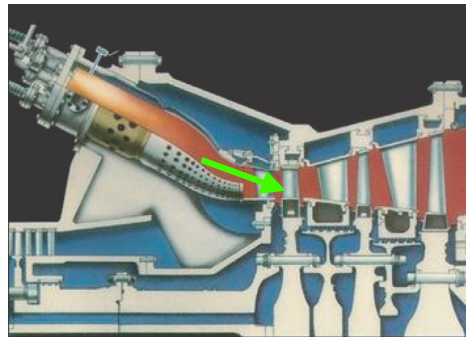

MS9001FA

### **Influence of blade rows interaction**

- ⇒ wakes, vortices shedding, potential interaction, shocks
- ⇒ large-scale pressure fluctuation drives unsteady energy exchange

### **Influence of combustor flow**

- ⇒ opportunities to open new frontiers in heat load management
- ⇒ freestream turbulence, hot streaks, fouling

## Unsteadiness and HP Turbine Heat Transfer

- ◆ Turbine blades used in gas turbine aircraft propulsion or power generation are highly “turbulated”
  - Leading Edge holes
  - Combustor Tu
  - Stator/rotor interaction
- ◆ Turbulent prediction tend to under-predict heat transfer coefficients (HTC)- particularly on pressure side
  - Lam/ turbulent transition can be neglected
- ◆ For many applications, effect of periodic unsteadiness on the time-averaged HTC is also minor
- ◆ Future opportunities:
  - Unsteadiness due to coolant pulsation
  - Hot Streaks
  - Leakages/ passive control devices

## Heat Transfer - Unsteady Coolant Blowing

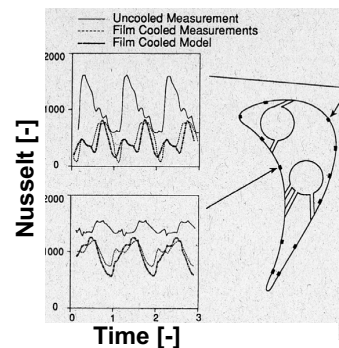
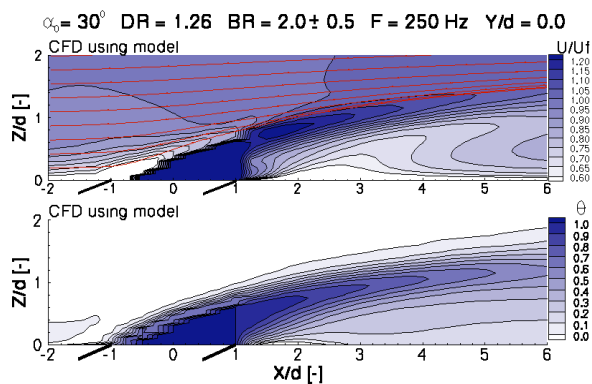

Abhari and Epstein (1994) MIT

- Large scale pressure fluctuation drives coolant blowing level
- Jet pulsation can change integrated heat load by up to ± 10% vs. steady
- 20 K increase of metal temperature can decrease blade lifetime by 50%
- Accurate design tools critical for film-cooled blade optimization

## Unsteady Rotor Stator Interaction Results in a pulsating of the Coolant Flow

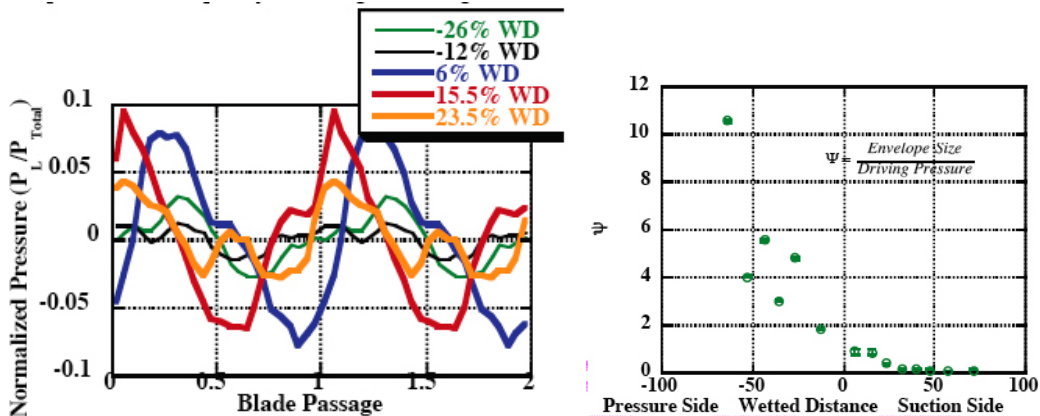

Ref: Haldeman, et. al. GT2006-90966 & 90968, Aerodynamic and Heat Flux Measurements in a Single Stage Fully Cooled Turbine—Part I&II

## Heat Transfer - Cooling Optimization

### cooling spatial scheme

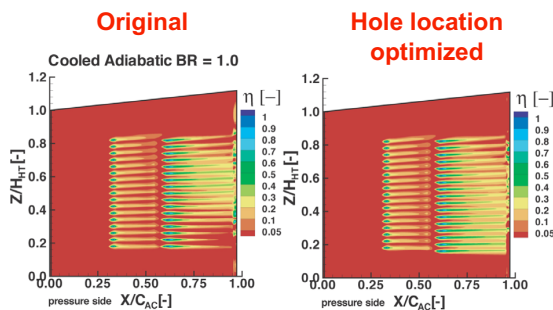

Burdet and Abhari (2006) ETH-Zürich

### coolant mass flow

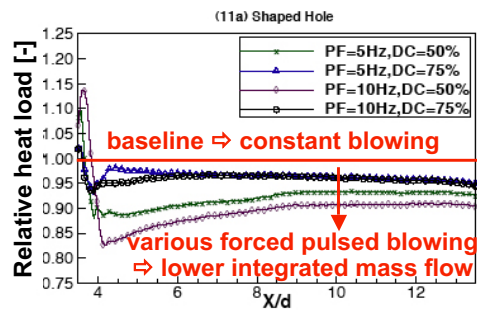

Ou and Rivir (2006) AFRL

- **Current design assumes over-optimized cooling**  $\Rightarrow$  coolant mass flow 20-30% core
- **Design goal : lower coolant mass flow and optimal heat protection**
  - $\Rightarrow$  take into account flow structures and unsteadiness
  - $\Rightarrow$  10-50% coolant mass flow reduction by force pulsed mass flow
- **Passive flow control**  $\Rightarrow$  medium/high technological risk but rewarding

# Heat Transfer - Freestream Turbulence

## Impact on cooling effectiveness

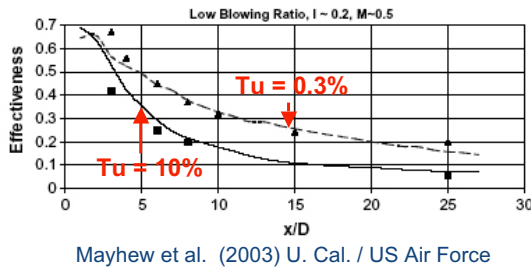

## Bypass transition (heat load level)

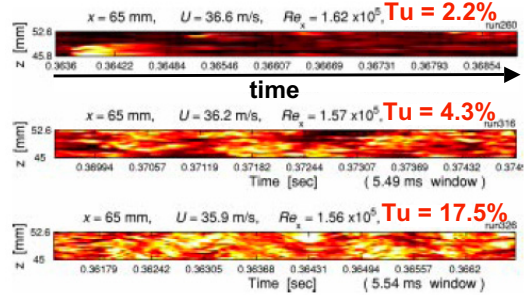

- **Compressor exit  $Tu \approx 10-18\%$  but not well integrated in turbine design**
- **Freestream  $Tu$  degrades cooling at low-medium coolant blowing  $\Rightarrow$  suction side**
- **Coupled with blade roughness degradation**
- **Opportunity for high freestream turbulence cooling studies**

## Heat transfer - Hot streaks migration

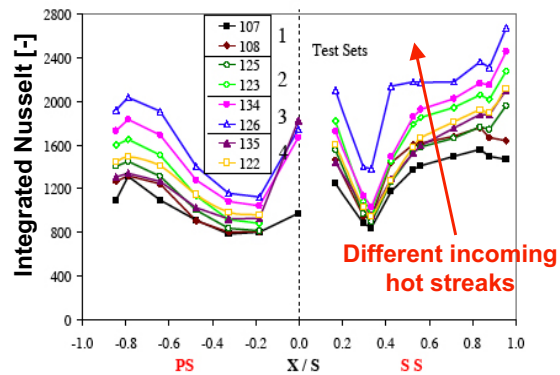
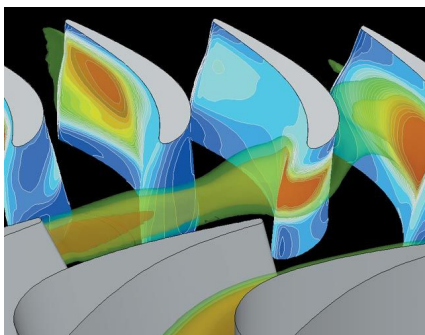

- **Hot streaks temperature difference up to 250 K**
- **Heat load can vary as much as 50% as a function of hot streak profile shape**
- **Impact on pressure side and blade tip  $\Rightarrow$  fatigue / cracking**
- **Current design uses sub-optimal air/fuel ratio  $\Rightarrow$  non-optimal fuel consumption**
- **A number of experimental studies: UTRC, OSU, MIT, ...**
- **Still impact on design is not fully explored. Opportunities for improvement  $\Rightarrow$  combustor flow / clocking, ....**

## Heat transfer - Hardware development for better design

### System level experiment and improved measurement technology

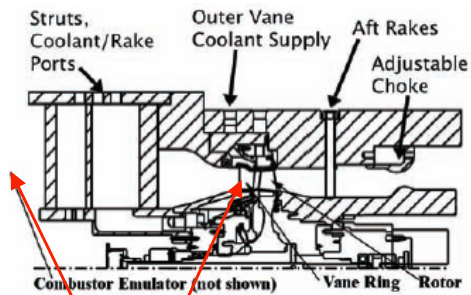

Haldeman et al. (2006) OSU / Honeywell

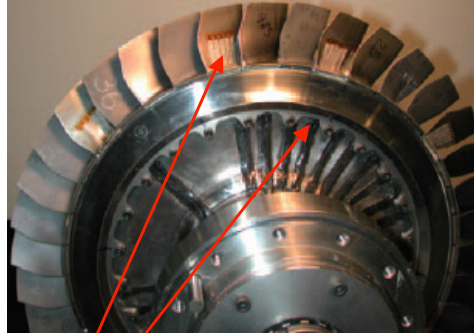

- **Simulating real engine working conditions**
- **Measurements techniques and access to be developed**
- **Enhance knowledge of unsteady heat transfer processes for better design**
- **Provide database for computational anchoring**

## Heat transfer - Software development for better design

- **Experimental heat transfer databases**

- ⇒ film-cooled blade
- ⇒ hot streaks

- **Implementation of multiscale effect in CFD**

- ⇒ injection models
- ⇒ conjugate heat transfer
- ⇒ small geometrical features

- **Turbulence models** to account for

- ⇒ freestream turbulence
- ⇒ roughness
- ⇒ anisotropy, Prandtl number

- **Processing tools**

- ⇒ Parallelism for tradeoff studies of heat management
- ⇒ Post-processing & probabilistic uncertainty of heat load prediction

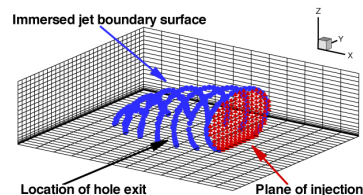

# Aeroelasticity

## Aeroelasticity - general overview

Aeroelasticity describes the unsteady interaction between the flow and the structure in turbomachinery.

Aeroelasticity phenomena require unsteady sources of excitation. They are ALWAYS present in turbomachinery.

Main sources of excitation:

- self excited / flutter
  - flow separation (fan, low pressure turbine)
  - shock impingement on blade (high pressure turbine)
- forced response
  - convective unsteadiness i.e wakes, distortion (all bladed parts)
  - unsteady potential field (turbines)

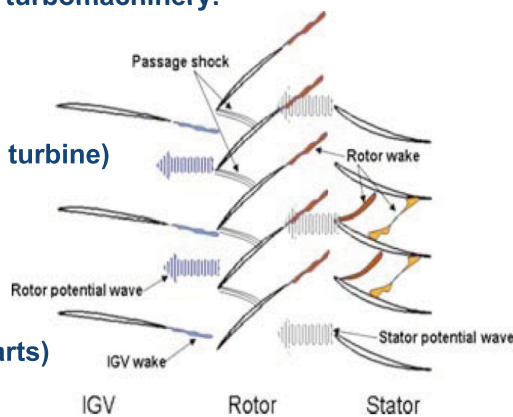

The potential of vibration for damage can only be assessed through knowledge of forcing and damping forces.

Li, He 2005



## Aeroelasticity - governing equations

Flow

**Continuity**

$$\frac{\partial \rho}{\partial t} + \frac{\partial \rho u}{\partial x} = 0$$

**Momentum**

$$\frac{\partial \rho u}{\partial t} + \frac{\partial \rho u u}{\partial x} = -\frac{\partial P}{\partial x}$$

**Energy**

$$\frac{\partial \rho e}{\partial t} + \frac{\partial \rho u h_0}{\partial x} = 0$$

Structure

$$\ddot{x} + \left(\frac{c}{m}\right)\dot{x} + \left(\frac{k}{m}\right)x = \underline{f_1(t)} + \underline{f_2(t)}$$

The interaction between the flow and the structure is a coupled, non-linear problem.

**Current engineering approach to the problem:**

linearization

=> superposition of harmonics

decoupling

=> no change in structure assumed

## Aeroelasticity - Off-design Conditions are Often Difficult to predict

Oscillating blades

- ♦ blade oscillates in a specified mode and frequency
- ♦ pressure measurements
- ♦ validation of influence coefficients
- ♦ aerodynamic damping can be calculated using the energy method
- ♦ flow can be visualized

linearization validated

- ♦ bending mode
- ♦ torsional mode

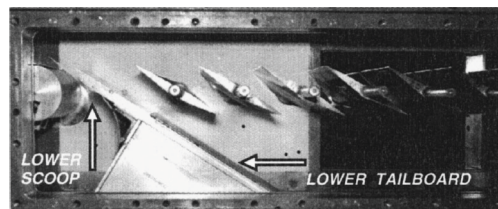

Lepicovsky 2001

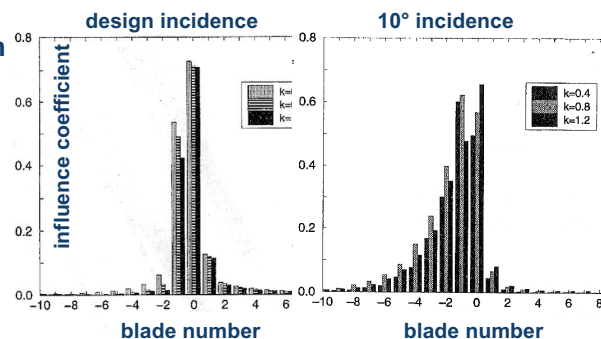

BUFFUM 1999

## Aeroelasticity - experimental oscillating cascade

---□--- PS: coupled  
 ---■--- SS: coupled  
 ---○--- PS: superposition  
 ---●--- SS: superposition

source 1: forced plunging motion

source 2: downstream gust generation

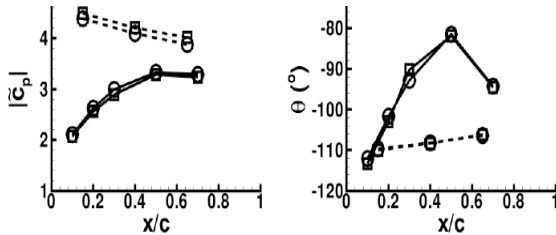

attached, subsonic flow

⇒ very good agreement for coupled or superimposed case

⇒ linearization valid

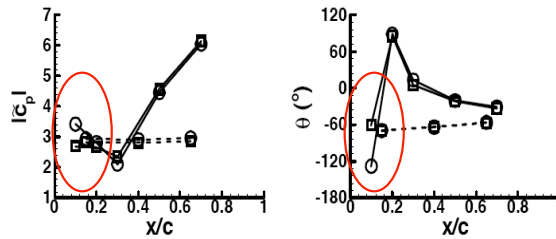

transonic flow with leading edge shock

⇒ leading edge discrepancies suggest local non-linearity

⇒ generally good agreement

Nowinski, Ott, Bölcş 2000

## Aeroelasticity - Mistuning

- non-linear flow modeling methods

- shock movement
- long wave inlet distortion
- separation

- structure modeling

- mistuning

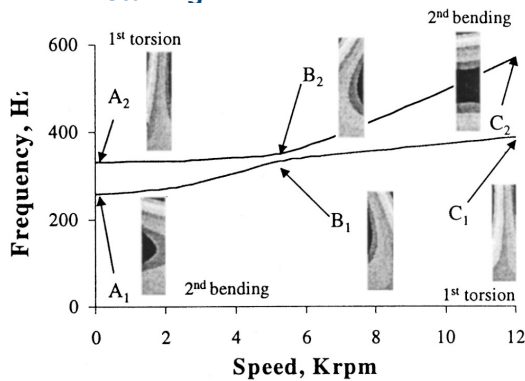

Marugabandhu, Griffin 2003

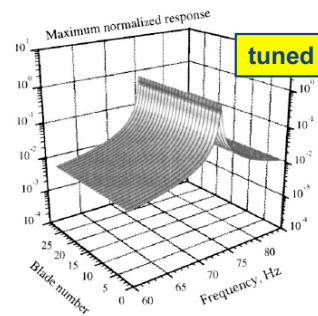

tuned

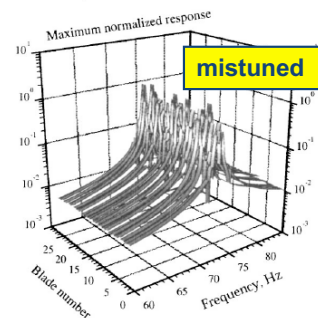

mistuned

Petrov, Ewins 2003

# Aeroelasticity - Aerodynamic Damping for Real Engines is not Well Understood

◆ Uncertainty in prediction of aerodynamic damping is very large

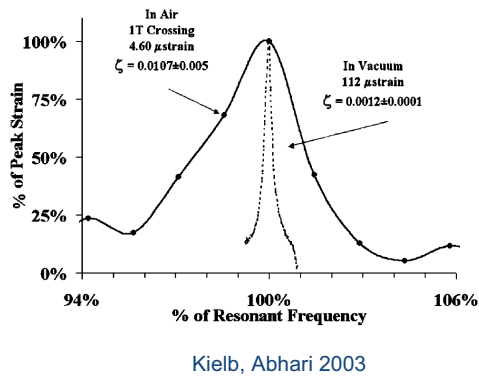
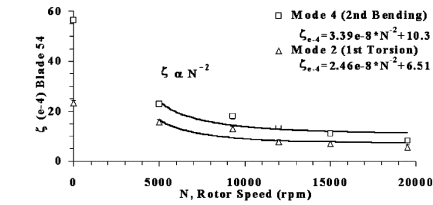
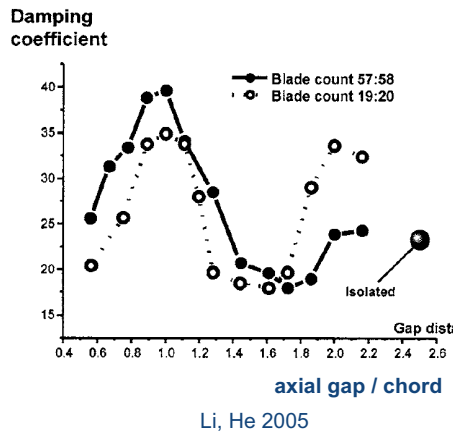

# Aeroelasticity - Forced Response

- 3D coupled unsteady flow computation
- requires very good application of boundary conditions i.e.
  - blade rows
  - neighboring blades
  - inlet and outlet
  - mistuning
- captures non-linear interactive effects between the blade motion and the flow
- currently limited by computational cost and power availability

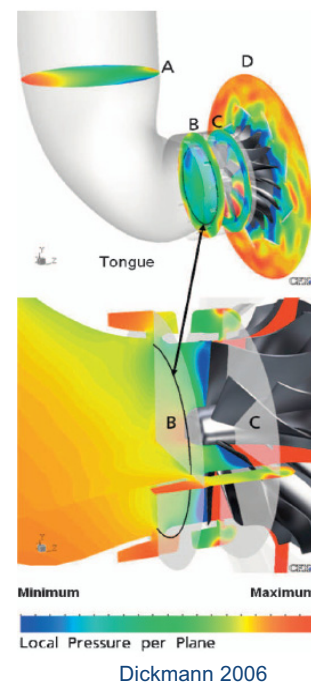
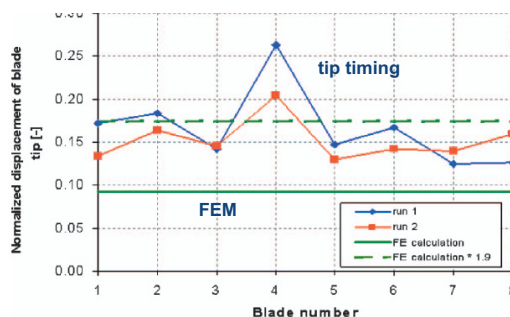

## Selected Future Research Opportunities to Improve Turbine Designs

- ◆ Performance
  - Leakage management including possibly passive control
  - Low Re number machines
  - Need Understanding of impact of anisotropic Tu
- ◆ Heat Transfer and Cooling
  - Unsteady film cooling (both experimental and computational)
  - Hot streak design tool
- ◆ Aeroelasticity
  - Better understanding how to increase aerodynamic damping
  - Robust Design tools for aerodynamic forces as well as mistuning
- ◆ Enabling Technologies
  - Advanced High Response Instrumentation
  - Experimentally anchored, computational models

## Engine-Realistic Flow Measurement to Understand 3D Unsteady Flow and Improve Design

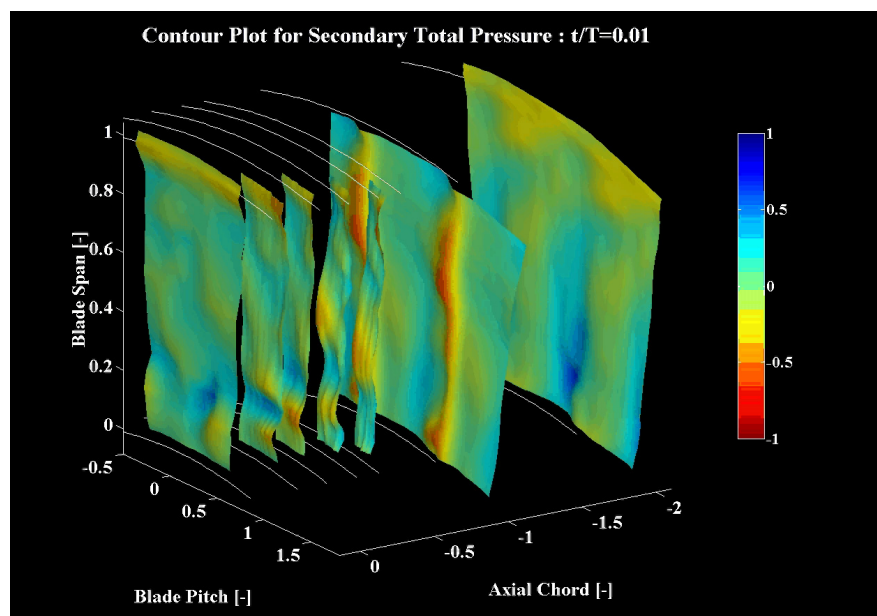

**Abstracts of  
Session Presentations**



# THE INFLUENCE OF WAKES, FREESTREAM TURBULENCE, AND DOWNSTREAM BLADE ROWS ON THE TRANSITION MECHANISMS IN LP TURBINES

M. Opoka, R. Thomas, and H.P. Hodson  
Whittle Laboratory  
University of Cambridge, U.K.

The interaction of upstream wakes with the low Reynolds number boundary layer, and in particular the separation bubble, on the suction side of LPT airfoils has enabled the design of LPT airfoils with increased levels of lift. The aim of this paper is to describe the influence of freestream turbulence, upstream wakes and downstream bladerows on the laminar-turbulent transition mechanisms that result from this interaction.

The study uses a linear cascade incorporating the T106A high lift Low Pressure Turbine blade. In order to reproduce the multistage LPT environment, two jointly driven systems of moving bars have been assembled upstream and downstream of the cascade and a turbulence grid was placed inside the cascade inlet duct. The upstream moving bar system is used to generate viscous wakes while the downstream moving bar system was designed to reproduce the suction surface pressure oscillations associated with the potential fields of a downstream bladerow. The tests have been performed at a Reynolds number of  $1.6 \times 10^5$  and at inlet freestream turbulence intensities of 0.5% and 4.0%.

Investigations of the separate effects of wake and potential field disturbances have been performed prior to the tests with the combined interactions. In the tests with only the upstream wakes at low inlet freestream turbulence intensities, the wakes were found to periodically induce laminar-turbulent transition downstream of the steady state separation line. This allowed separated flow transition to proceed naturally between the wakes and via a Kelvin-Helmholtz breakdown of the shear layer (induced by wake's negative jet) under the wakes. At the higher level of inlet freestream turbulence, the size of the separation bubble was reduced and spanwise vortices were not observed.

In the absence of the upstream wakes, the downstream potential field interacted with the rear part of the blade suction surface through cyclic changes of the pressure field. The magnitudes of the suction surface pressure variations induced by the downstream bars were approximately half of those measured in the investigation with only upstream wakes. The location of transition onset was observed to oscillate with the fluctuating pressure field, moving upstream with amplification of the pressure gradient and downstream with relaxation of the pressure gradient. At the low level of inlet freestream turbulence (0.5%), a separation bubble formed on the rear part of the suction surface. The velocity field revealed the presence of Kelvin-Helmholtz type shear layer vortices. At the higher inlet freestream turbulence level (4%), separation was prevented by the early onset of transition and the shear layer vortices were not observed. At both levels of inlet freestream turbulence, the time-averaged momentum loss in the boundary layer at the trailing

edge increased relative to that in steady flow. This increase of momentum thickness was due to an enlargement of the turbulent wetted area.

When investigating the combined wake and potential field interaction, the ratio of the pitches of the upstream bar system, the cascade and the downstream bar system was 1.5:1:1.5. The wakes dominate the transition process. Nevertheless, shifting the phase of downstream potential field interaction with respect to the upstream wake position revealed a ‘clocking’ effect. Six relative phase locations, or ‘clocking’ positions, have been investigated. The trailing edge integral parameters and the pitchwise traverse at 15% of axial chord downstream of the cascade were compared. For the lower level of inlet freestream turbulence, the optimum relative phase location of the upstream and downstream bar system produced a 5% reduction of trailing edge momentum thickness in comparison to the worst relative phase location. For the increased level of inlet freestream turbulence the optimum clocking produced a 10% reduction.



## UNSTEADY WAKE-INDUCED TRANSITION ON AXIAL COMPRESSOR BLADES— CALMING AND LEADING EDGE INTERACTION EFFECTS

G.J. Walker and A.D. Henderson  
School of Engineering  
University of Tasmania, Australia

J.D. Hughes  
Rolls-Royce  
Derby, U.K.

The beneficial application of calming effects associated with wake-induced turbulent strips on axial turbine blades has led to significant performance improvements for aero-engine low-pressure turbines in recent years. It is not yet clear whether the design of axial compressor blades could be improved by the application of similar design principles. The increased loss in the turbulent strips needed to promote significant regions of calmed flow must be carefully weighed against the potential loss reductions due to calming. However, performance enhancements for compressors are not simply confined to increases in efficiency or blade loading: here improvements in operating stability and stall margin are also of great importance.

An accurate prediction of the appearance and development of wake-induced turbulent strips is a necessary prerequisite for any rational application of calming effects in compressor blade design. The strength and periodicity of incident wakes are key aspects of the disturbance field, and the blade geometry and time-mean surface pressure distribution may significantly influence the boundary layer response. Leading edge interactions associated with wake chopping are of vital importance, as the leading edge appears to be the principal receptivity site for disturbances leading to the appearance of wake-induced turbulent strips on axial compressor blade suction surfaces.

This presentation commences by reviewing data of Hughes and Henderson concerning the effects of blade loading, axial row spacing, wake-wake interactions and free-stream turbulence on unsteady transitional flow on the outlet stator blades of a 1.5-stage axial compressor. The principal source of unsteadiness is the passage of blade wakes from the adjacent rotor row. Hot wire anemometer measurements are used to observe the rotor wake disturbances and the manner in which they are modified by interaction with wakes from the inlet guide vanes further upstream and the background turbulence level. Modification of the inflow turbulence level by installation of a turbulence grid is observed to have significant effects on the wake decay and interaction processes. This in turn modifies the level of periodic disturbance experienced by the outlet stator blades. A surface hot-film array is used to observe the resulting development of transitional flow.

Leading edge interaction effects associated with wake chopping are next discussed, with reference to recent complementary studies carried out in Tasmania (Henderson et al., [1]) and the Whittle Laboratory, Cambridge (Wheeler et al., [2]). Both teams used the UNSFLO code of Giles to predict the unsteady laminar boundary layer behavior in a stator leading edge region. This code solves the unsteady thin-layer Navier-Stokes equations for the viscous flow near the blade surface and treats the rest of the flow domain as inviscid. The effects of upstream wakes are modeled by imposing inviscid wake profiles that approximate the measured wake profiles on the inflow boundary. Viscous diffusion and dissipation due to turbulence within the wakes is ignored, but this approximation is considered acceptable over the restricted region of interest within 10-20% of chord

from the leading edge. A quasi-steady model is applied to examine the effects of periodic wake disturbances on the laminar boundary layer stability. The influence on stability of perturbations in boundary layer Reynolds number and shape factor are found to be additive. These perturbations are predicted to destabilize the suction surface boundary layer and stabilize the pressure surface boundary layer for both Tollmien-Schlichting and bypass type instability phenomena.

These analytical predictions of leading edge interaction effects are supported by experimental observations in two different research compressors having similar general configurations but different blade profiles in the outlet stator row. The Tasmanian blades are of British C4 section with no discontinuity in leading edge surface curvature, and a suction peak close to the leading edge at design. The Cambridge blades have a more modern controlled diffusion profile, with a circular arc leading edge and the main suction peak further back; they also have a localized pressure spike associated with the surface curvature discontinuity at the end of the leading edge arc.

Several experimental techniques were applied to validate the computational procedure. A surface hot-film array was used in the Tasmania compressor to observe the unsteady boundary layer response around the compressor blade leading edge and the resulting turbulent flow development over a range of operating conditions (covering variations of incidence, Reynolds number and free-stream turbulence level). Observations of individual disturbance and turbulent breakdown events indicate that both natural and bypass transition mechanisms may occur; and some boundary layer disturbances may decay in regions of accelerating flow without initiating a turbulent breakdown. Detailed unsteady boundary layer and surface pressure measurement were made in the Cambridge compressor. The generally good agreement between prediction and measurement observed by both teams indicates that the effect of incidence fluctuations due to wake chopping is primarily an inviscid process, and the boundary layer response to the resulting fluctuation in surface pressure distribution is essentially quasi-steady.

In conclusion, some fundamental differences between unsteady wake-induced transition phenomena on axial compressor and turbine blades are discussed, and some areas meriting further basic research are suggested. The possible influence of surface curvature on the development of streaky structures responsible for bypass transition is considered worthy of further investigation. This could conceivably be important in the leading edge region, where surface curvatures are high: surface curvature may certainly influence mixing in fully developed turbulent flow. Numerical and physical experiments to isolate the influence of pressure gradient and surface curvature on bypass transition would be useful: it is concerning that most available bypass transition data has been obtained from flat plate experiments with zero surface curvature. The ability of a localized suction peak (or “pressure spike”) to promote transition in a region of accelerating flow also needs further investigation: this requires an ability to predict the decay of incipient turbulent spots rather than the reverse transition of a fully developed turbulent boundary layer.

## References

1. Henderson, AD, Walker, GJ & Hughes, JD, “Unsteady Transition Phenomena at a Compressor Blade Leading Edge”, ASME Paper GT2006-90641, Turbo Expo 2006, Barcelona.
2. Wheeler, APS, Miller, RJ & Hodson, HP, “The Effect of Wake Induced Structures on Compressor Boundary-Layers”, ASME Paper GT2006-90892, Turbo Expo 2006, Barcelona.

## COMPLEX WAKE-BLADE AND WAKE-WAKE INTERACTIONS IN MULTISTAGE TURBOMACHINES

Yi Chih Chow, Francesco Soranna, Oguz Uzol, and Joseph Katz  
Department of Mechanical Engineering  
The Johns Hopkins University  
Baltimore, MD

The flow structure and spatial distribution of turbulence around a rotor blade within a multistage axial turbomachines are inherently affected by interaction with wakes shed by upstream blades. Several associated phenomena have been investigated experimentally by performing PIV measurements in a facility that has blades and fluid with matched refractive indices. This setup enables unobstructed view of the entire flow field including boundary layers, wakes hub and tip vortices. The presentation provides a few striking examples of the complex turbulence and flow structure generated by wake-blade and wake-wake interactions, such as:

- i. Modifications to the turbulence within an IGV wake impinging on a blade due to exposure to the strain field generated by this blade, including effects of rapid straining, compression, wall blockage and highly inhomogeneous turbulence production.
- ii. Periodic changes to the velocity profile and scales of the blade boundary layer, which are caused by wake impingement. Analysis demonstrates that the unsteady pressure field generated due to the wake passage stabilizes the boundary layer near the trailing edge of the rotor blade.
- iii. Shearing of the rotor wake by the non-uniform flow field generated by upstream IGV blades causes inhomogeneous turbulence production and formation of turbulent hot spots. The spatial distribution of turbulence differs substantially from that observed in prior studies of curved wakes. Specific causes and mechanisms are identified.
- iv. Modifications to the flow structure and turbulence near the tip of one blade due to impingement of a tip vortex generated by another blade in the same rotor.

## THE DYNAMICS OF THE HORSESHOE VORTEX AND ASSOCIATED ENDWALL HEAT TRANSFER

Thomas J. Praisner and Daniel R. Sabatino  
Pratt & Whitney United Technologies  
East Hartford, CT

Charles R. Smith  
Lehigh University  
Bethlehem, PA

When a turbulent boundary layer approaches a bluff-body obstruction, the body-generated adverse-pressure gradient precipitates a separation process that forces the impinging boundary layer vorticity to reorganize into a horseshoe vortex. The horseshoe vortex circumscribes the leading edge of the bluff body with legs extending downstream, and is characterized by significant aperiodic unsteadiness [1, 2]. In turbomachinery applications, the leg of horseshoe vortex on the pressure side of the airfoil has been shown to have high aerodynamic losses associated with it [3, 4]. RANS-based performance predictions in endwall regions of multi-stage turbines and cascades, where the horseshoe vortex is a dominant flow feature, have been shown to be clearly deficient [5, 6, 7, 8]. Additionally, the leading-edge region of turbulent endwall flows is of interest in turbomachinery applications because the presence of the horseshoe vortex system has been shown to increase local endwall heat transfer rates by as much as 300% above flat plate levels [9, 10]. High heat transfer rates in leading-edge regions of high-pressure turbines are known to cause thermal-mechanical fatigue, spalling of thermal barrier coatings, and airfoil endwall/platform burning.

Here we report on instantaneous flow topology and the associated endwall heat transfer in the leading-edge endwall region of a symmetric airfoil. An experimental technique was employed that allowed the simultaneous recording of instantaneous particle image velocimetry flow field and thermochromic liquid-crystal-based endwall heat transfer data. The endwall flow is dominated by the horseshoe vortex while a secondary vortex develops sporadically immediately upstream of the horseshoe vortex. The region upstream of the horseshoe vortex is characterized by a bimodal switching of the near-wall reverse flow, which results in quasi-periodic eruptions of the secondary vortex. The bimodal switching of the reverse flow in the vicinity of the secondary vortex is linked to the temporal behavior of the down-wash fluid on the leading edge of the foil. Frequency analysis of the flow field and endwall heat transfer data, taken together, indicate that the eruptive behavior associated with the horseshoe vortex occurs at a frequency that is essentially the same as the measured turbulence bursting period of the impinging turbulent endwall boundary layer. A typical example of instantaneous symmetry-plane vorticity distributions juxtaposed with the corresponding instantaneous endwall Stanton number distributions is shown in Figure 1. Off the symmetry plane, the horseshoe vortex grows in scale, and ultimately experiences a bursting, or breakdown, upon being subjected to an adverse pressure gradient.

The data presented here elucidate the high level of relatively large-scale unsteadiness associated with the horseshoe vortex and the resulting enhancement of endwall heat transfer, phenomena which are intractable with even time-accurate RANS-based simulations. This work underscores the need for more advanced computational work, such as LES and DNS studies, that needs to be directed at predicting and understanding endwall flows.

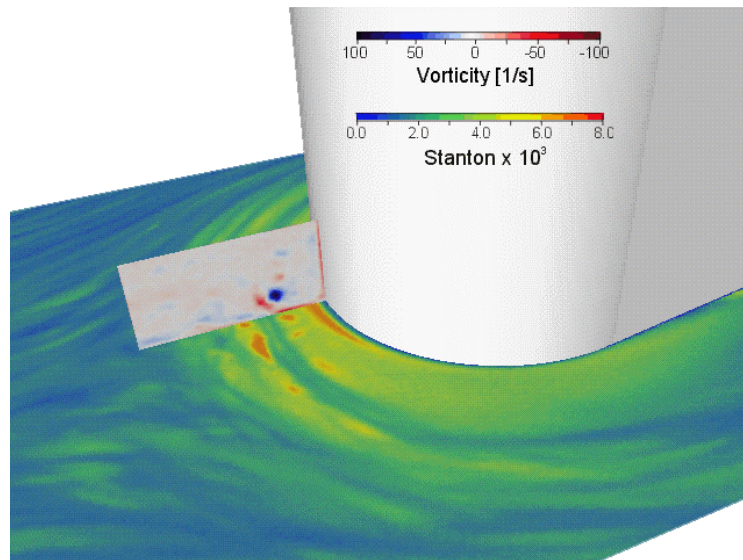

Figure 1. Instantaneous symmetry-plane vorticity distribution with the corresponding instantaneous endwall Stanton number distribution.

#### References:

- [1] Devenport, W.J. and Simpson, R.L., 1990, "Time-Dependent and Time-Averaged Turbulence Structure Near the Nose of a Wing-Body Junction," *Journal of Fluid Mechanics*, Vol. 210, pp. 23-55.
- [2] Praisner, T.J., Seal, C.V., Takmaz, L., Smith, C.R., 1997, "Spatial-Temporal Turbulent Flow-Field and Heat Transfer Behavior in End-Wall Junctions," *International Journal of Heat and Fluid Flow*, Vol. 18, No. 1, pp. 142-151.
- [3] Sjolander, S.A., 1975, "The Endwall Boundary Layer in an Annular Cascade of Turbine Nozzle Guide Vanes," Carleton Univ., Dept. of Mech. and Aeron. Engrg., Ottawa, Canada, TR ME/A 75-4.
- [4] Langston, L.S., Nice, M.L., and Hooper, R.M., 1976, "Three-Dimensional Flow Within a Turbine Cascade Passage," ASME Paper No. 76-GT-50.
- [5] Praisner, T. J., Clark, J. P., Grover, E. A., Bertuccioli, L., and Zhang, D., 2003, "Challenges in Predicting Component Efficiencies in Turbines with Low Reynolds Number Blading," *Minnowbrook IV: 2003 Workshop on Transitional and Unsteady Aspects of Turbomachinery Flows*, NASA/TM-2004-212913, page 58.
- [6] Praisner, T. J., Grover, E. A., Rice, M. J., and Clark, J. P., 2004, "Predicting Transition in Turbomachinery, Part II – Model Validation and Benchmarking," ASME Paper No. GT-2004-54109.
- [7] Gier, J., Ardey, S., and Heisler, A., 2000, "Analysis of Complex Three-Dimensional Flow in a Three-Stage LP Turbine by Means of Transitional Navier-Stokes Simulation," ASME Paper No. 2000GT-645.
- [8] Hartland, J.C., Gregory-Smith, D.G., Harvey, N.W., and Rose, M.G., 2000, "Nonaxisymmetric Turbine End Wall Design: Part II – Experimental Validation," *Journal of Turbomachinery*, Vol. 122, pp. 286-293.
- [9] Graziani, R.A., Blair, M.F., Taylor, J.R., and Mayle, R.E., 1980, "An Experimental study of Endwall and Airfoil Surface Heat Transfer in a Large Scale Turbine Blade Cascade," *Journal of Engineering for Power*, Vol. 102, pp. 257-267.
- [10] Giel P. W., Thurman, D. R., VanFossen, G. J., Hippensteele, S. A. and Boyle, R. J., 1998, "Endwall Heat Transfer Measurements in a Transonic Turbine Cascade", *ASME J. Turbomachinery*, vol. 120, Apr. 1998, pp. 305-313.

## UNSTEADY TURBINE FLOWS AND HEAT FLUXES AT OXFORD, THEN AND NOW

Martin Oldfield  
University of Oxford  
Oxford, U.K.

The Oxford research into unsteady turbine aerodynamics and heat transfer over the last 3 decades is informally reviewed and discussed. The use of short duration facilities and transient high-bandwidth instrumentation techniques has been ideally suited to unravelling the inevitably unsteady flows in turbines.

Early work in a short duration linear cascade used microsecond exposure schlieren photography to interpret unsteady phenomena seen in surface heat flux and pressure records [1 – 8]. Phenomena observed include simulated wake and shock wave passing which cause large, rapid fluctuations in surface heat flux [1]. These were related to measure heat flux changes by a deceptively simple theory [5]. Shock waves passing the blade leading edge shed previously unseen vortex bubbles which when convected along the blade surface generating pulses of heat flux [2, 6]. Examination of the schlieren images reveal other phenomena, such as Mach waves shed by the von Karman vortices in the blade wakes and the unsteady passage vortex core.

In the late 1980s the tunnel was converted to run a full rotating 3-D turbine stage and the unsteady phenomena studied in the linear cascade were seen again. Wideband downstream traverse measurements were used to show the unsteadiness propagating through the stage. A sample movie clip assembled from these measurements shows the downstream total pressure map changing as the rotor moves past the stator [9, 10].

More recently, flow visualisation has shown that, even in “steady” experiments, external film-cooling flows are highly unsteady [11] and bring into question the use of steady CFD to predict effectiveness and heat transfer coefficients. Is LES the way forwards?

Similarly, PIV flow measurements in a large (1 m chord) “steady” cascade show that the passage and overtip leakage vortices are highly unsteady as perturbations in the transverse vorticity in the upstream sidewall boundary layer are wrapped around the blade [12,13]. The separation bubble under the blade tip is also seen to be very unsteady, with velocity standard deviations of nearly 50% of the mean flow Can we trust averaging?

Be sceptical of steady CFD or averaged results of these inherently unsteady flows. Try to measure average and unsteady features together in order to understand the flow phenomena.

### References

1. **Doorly, D.J. and Oldfield, M.L.G., 1985a**, "Simulation of wake passing in a stationary turbine rotor cascade," *J. Propulsion & Power*, Vol. 1, pp. 316-318.

2. **Doorly, D.J. and Oldfield, M.L.G., 1985a**, "Simulation of wake passing in a stationary turbine rotor cascade," *J. Propulsion & Power*, Vol. 1, pp. 316-318.
3. **Doorly, D.J. and Oldfield, M.L.G., 1985b**, "Simulation of the effects of shock wave passing on a turbine rotor blade," *ASME Journal of Engineering for Gas Turbines and Power*, Vol. 107, pp. 998-1006, (Also ASME Paper 85-GT-112)[ ASME Gas Turbine Award, 1985. for the most outstanding technical paper].
4. **Johnson, A.B., Rigby, M.J. and Oldfield, M.L.G., 1989**, "Unsteady aerodynamic phenomena in a simulated wake and shock wave passing experiment," AGARD-CP-468/469, *Unsteady Phenomena in Turbomachines*, Luxembourg, 1989.
5. **Johnson, A.B., Rigby, M.J., Oldfield, M.L.G., Ainsworth, R.W. and Oliver, M.J., 1989**, "Surface heat transfer fluctuations on a turbine rotor blade due to upstream shock wave passing," *ASME Journal of Turbomachinery*, Vol. 111, pp. 105-115 (also ASME 88-GT-172).
6. **Johnson, A.B., Rigby, M.J. and Oldfield, M.L.G., and Giles, M.B. 1990**, "Nozzle guide vane shock wave propagation and bifurcation in a transonic turbine rotor," ASME IGTI 1990 Gas Turbine Conference, Brussels, ASME 90-GT-310.
7. **Rigby, M.J., Johnson, A.B., Oldfield, M.L.G. and Jones, T.V., 1989**, "Temperature scaling of turbine blade heat transfer with and without shock wave passing," Proc. ISOABE 9th Symposium on Air Breathing Engines, Athens, 1989, AIAA.
8. **Rigby, M.J., Johnson, A.B., Oldfield, M.L.G., 1990**, "Gas turbine rotor blade film cooling with and without simulated NGV shock waves and wakes," ASME IGTI 1990 Gas Turbine Conference, Brussels, ASME 90-GT-78.
9. **Miller, R.J., Moss, R.W., Ainsworth, R.W. and Horwood, C. K., 2003**, "Time-Resolved Vane-Rotor Interaction in a High-Pressure Turbine Stage" *ASME J. Turbomachinery*. 125, 1 (2003)
10. **Miller, R.J., Moss, R.W., Ainsworth, R.W., Harvey, N.W., 2003**, "Wake, shock and potential field interactions in a 1.5 stage turbine: part I—vane-rotor and rotor-vane interaction. *ASME Journal of Turbomachinery* 125 (1), 33–39.
11. **Sargison, J. E., Oldfield, M. L. G., Guo, S. M., Lock, G. D. and Rawlinson, A. J., 2005**, "Flow visualisation of the external flow from a converging slot-hole film-cooling geometry", *Experiments in Fluids*, Feb 2005, <http://www.springerlink.com/index/10.1007/s00348-004-0892-1>
12. **Palafox, P., Oldfield, M. L. G., Jones, T. V., LaGraff, J. E., 2005**, "PIV Maps of Tip Leakage and Secondary Flow Fields on a Low Speed Turbine Blade Cascade with Moving Endwall". ASME/IGTI Turbo Expo '05 June 6-9 2005, Reno, ASME Paper GT2005-68189 (to be published in the *Journal of turbomachinery*).
13. **Palafox, P., Oldfield, M. L. G., Ireland P.T., Jones, T. V., LaGraff, J. E., 2006**, "Blade Tip Heat Transfer and Aerodynamics in a Large Scale Turbine Cascade With Moving Endwall", ASME/IGTI Turbo Expo '06 May 8-11 2006, Barcelona, ASME Paper GT2006-90425.

## COMPARISON OF TURBINE CASCADE MEASUREMENTS OF SKIN FRICTION, LIMITING STREAMLINE DIRECTION, AND HEAT TRANSFER

Brian M. Holley and Lee S. Langston  
Department of Mechanical Engineering  
University of Connecticut  
Storrs, CT

Surface measurements of skin friction, limiting streamline direction, and heat transfer taken in a large scale plane turbine cascade are presented and compared. The measurements of skin friction and limiting streamline direction are recent additions [1] to a data set for a particular cascade at a particular set of flow conditions. This data set now comprises surface measurements of skin friction, limiting streamline direction, static pressure and heat transfer as well as ten planes of five-hole pneumatic probe flow field measurements upstream, within and downstream of the cascade [1-3].

Skin friction and limiting streamline direction are obtained using oil film interferometry (OFI) [4]. During an experiment, a locally applied very thin oil film is acted upon by skin friction along limiting streamlines. Subsequent interferometric patterns in the oil film are used to determine spatial oil thickness variations, from which skin friction values and limiting streamline direction are inferred. The OFI results quantitatively display flow features such as the endwall saddle point, a pressure side separation bubble on the airfoil, and separation lines on both the endwall and airfoil. Because of dust, attachment lines are only qualitatively displayed.

The heat transfer measurements were taken on the same cascade under similar flow conditions during an earlier study [3]. Thermocouple data taken on a surface with constant heat flux provided the heat transfer measurements. These surface measurements are all time-averaged, and any unsteadiness is integrated into the measurement.

Comparison of the experimental results show that locations of high heat transfer cannot be inferred in general from locations of high skin friction. The highest levels of heat transfer occur where free stream flow is brought in contact with the cascade surface, and the limiting streamline direction measurements help indicate where this can take place. For example, there is high heat transfer along the airfoil's primary attachment line, where with very small span-wise flow the interpolated skin friction is zero. The saddle point is another location where a local maximum in heat transfer coincides with a local minimum in skin friction. The highest heat transfer was measured on the suction side of the airfoil near the endwall, where there is an attachment line associated with a small corner vortex. Unlike the airfoil's primary attachment line, there is a moderate to high component of skin friction along this attachment line. On the endwall, the heat transfer is highest where there is mixing associated with wake interaction, which coincides with low to moderate skin friction. So, Reynolds analogy is not reliable for the diversity of flows in this cascade.

Similarly, locations of high skin friction do not always coincide with locations of high heat transfer. The location of the highest measured skin friction is on the suction side of the primary attachment line, where the flow is strongly accelerated and there is a thin boundary layer, and this does coincide with high heat transfer. Further along the suction side of the airfoil, there is highly skewed flow with high skin friction, and this also coincides with moderate to high heat transfer. Flow on portions of the endwall, however, remains attached as it migrates down the cross-passage pressure gradient, where it becomes accelerated and highly skewed. There, the



skin friction is high, but the heat transfer is moderate to low. In the region of uncovered turning, the flow along the endwall is believed to be turbulent [5-6], which coincides with both high skin friction and heat transfer. The applicability of Reynolds analogy is dependent upon the fluid mechanisms that take place locally in the cascade.

The fluid mechanisms that bring about high heat transfer are not always coincident with the mechanisms that bring about high skin friction. The mechanisms for high heat transfer are those that bring free stream flow to the surfaces: the horseshoe vortex, saddle point, primary attachment line, endwall-wake interaction, and turbulence. Mechanisms for high skin friction are thin boundary layers, highly accelerated flow, highly skewed flow, and turbulent flows. The comparison of heat transfer, skin friction and limiting streamline measurements show where these mechanisms coincide and where they do not.

[1] Holley, B.M. and Langston, L.S., 2006, "Surface Shear Stress and Pressure Measurements in a Turbine Cascade," GT2006-90580, Proceedings of ASME Turbo Expo 2006, Barcelona, Spain, May 8-11, (Accepted for publication *ASME Journal of Turbomachinery*).

[2] Langston, L.S., Nice, M.L., and Hooper, R.M., 1977, "Three Dimensional Flow within a Turbine Cascade Passage," *ASME Journal of Engineering for Power*, 99, pp. 21-28.

[3] Graziani, R.A., Blair, M.F., Taylor, J.R., and Mayle, R.E., 1980, "An Experimental Study of Endwall and Airfoil Surface Heat Transfer in a Large Scale Turbine Blade Cascade," *Journal of Engineering for Power*, 102, pp. 257-267.

[4] Holley, B.M., 2006, "Surface Shear Stress and Pressure Measurements in a Turbine Cascade," GT2006-90581, Proceedings of ASME Turbo Expo 2006, Barcelona, Spain, May 8-11.

[5] Harrison, S., 1990, "Secondary Loss Generation in a Linear Cascade of High-Turning Turbine Blades," *ASME Journal of Turbomachinery*, 112, pp. 618-624.

[6] Harrison, S., 1992, "The Influences of Blade Lean on Turbine Losses," *ASME Journal of Turbomachinery*, 114, pp. 184-190.

## AERODYNAMIC AND HEAT FLUX MEASUREMENTS IN A FULLY COOLED HPT

C.W. Haldeman, R.M. Mathison, M.G. Dunn, S. Southworth, and J.W. Harral  
The Ohio State University  
Columbus, OH

G. Heitland  
Honeywell Aerospace  
Phoenix, AZ

This presentation describes the experimental approach utilized to perform experiments using a fully cooled rotating turbine stage operating in a short-duration blowdown rig to obtain film effectiveness measurements. Significant changes to the previous experimental apparatus were implemented to meet the experimental objectives. The modifications include the development of a synchronized blowdown facility to provide cooling gas to the turbine stage, installation of a heat exchanger capable of generating a uniform or patterned inlet temperature profile, novel utilization of temperature and pressure instrumentation, and development of robust double-sided heat flux gauges. With these modifications, time-averaged and time-accurate measurements of temperature, pressure, surface heat flux, and film effectiveness can be made over a wide range of operational parameters duplicating the non-dimensional parameters necessary to simulate engine conditions. Data from low Reynolds number experiments are presented to demonstrate that all appropriate scaling parameters can be satisfied and that the new components have operated correctly.

Along with airfoil surface heat transfer and surface pressure data, temperature and pressure data from inside the coolant plenums of the vane and rotating blade airfoils will be presented. Pressure measurements obtained inside the vane and blade plenum chambers illustrate passing of the wakes and shocks as a result of vane/blade interaction.

The measurements noted above are presented in both time-averaged and time-accurate formats. The results include the heat transfer at multiple spans on the vane, blade, and rotor shroud as well as flow path measurements of total temperature and total pressure. Surface pressure measurements are presented for the vane and the blade at the mid span, location as well as the rotor shroud.

## EFFECTS OF INLET FLOW CONDITIONS ON ENDWALL FLOWS IN TURBINE VANE PASSAGES

Karen A. Thole  
The Pennsylvania State University  
Mechanical and Nuclear Engineering Department  
University Park, PA

Traditionally it has been considered that the secondary flows generated in the endwall region of a turbine vane passage are composed of a horseshoe vortex that develops into a pressure side leg and suction side leg. As these vortices convect along the endwall, the pressure side leg develops into what is known as the passage vortex that is promoted through the crossflow present from the pressure gradient from the pressure to the suction side of the adjacent airfoil. What is assumed, however, in this secondary flow representation is the presence of a canonical boundary layer that is approaching the turbine vane leading edge-endwall juncture. This assumption for a turbine application is not likely to be correct given the complexities of the exiting combustor flows.

The flow and thermal fields at the combustor-turbine junction in a gas turbine engine is highly complex and cannot be idealized by a two-dimensional, turbulent boundary layer exiting the combustor. Gas turbine combustors, particularly for aero engine designs, often contain large dilution holes, film-cooling holes along the approaching liner, and some type of leakage juncture at the combustor-turbine interface. This type of combustor design produces non-uniformities near the platform in both the span (radial) and pitch (circumferential) directions with large levels of turbulence in the mainstream.

The results that will be presented indicate the importance of quantifying the proper inlet conditions to the turbine, particularly in the near platform region. Flowfield measurements in the passage for a flow condition similar to what would exit a gas turbine combustor indicate a secondary flow pattern different than that of an approaching two-dimensional turbulent boundary layer. Figure 1 shows that while the suction side leg of the horseshoe vortex was much smaller than it is for a turbulent boundary layer, the passage vortex became much stronger for the more representative combustor flow. In addition, a counter-rotating vortex above the passage vortex was identified. Both of these vortices can be explained by the total pressure variation exiting the combustor.

Convective heat transfer measurements along the endwall also indicate differences depending upon whether there is an approaching two-dimensional turbulent boundary layer or a more realistic combustor flow. Figure 2 compares measured Stanton number contours on the endwall. As can be seen from these measurements, higher heat transfer coefficients result for the case where there is a leakage slot just upstream of the turbine vane. This leakage flow is a design feature in much combustor-turbine junctures.

To mitigate or control the effects of the secondary flows in a turbine vane passage, it is paramount to understand the flow exiting the combustor.

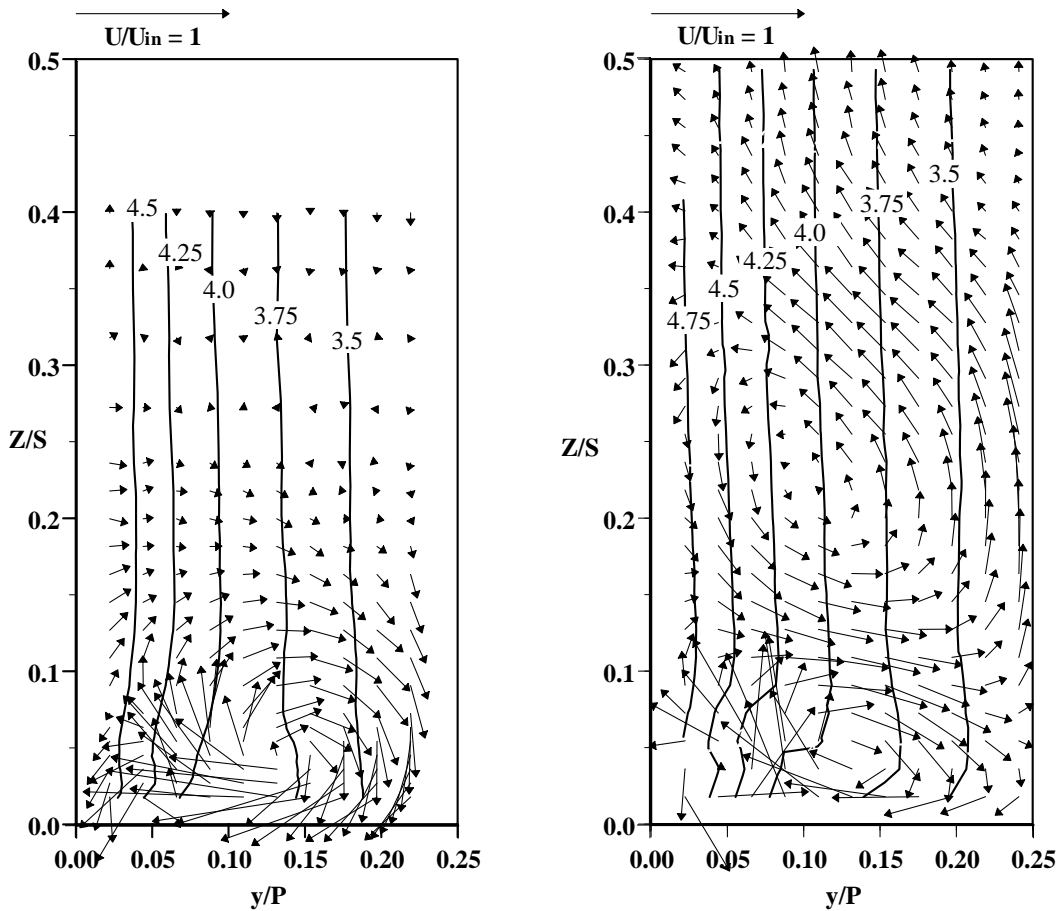

Figure 1. Measurements of secondary flowfields in a turbine vane passage for an incoming turbulent boundary layer (left) and an incoming more realistic combustor exit flow (right).

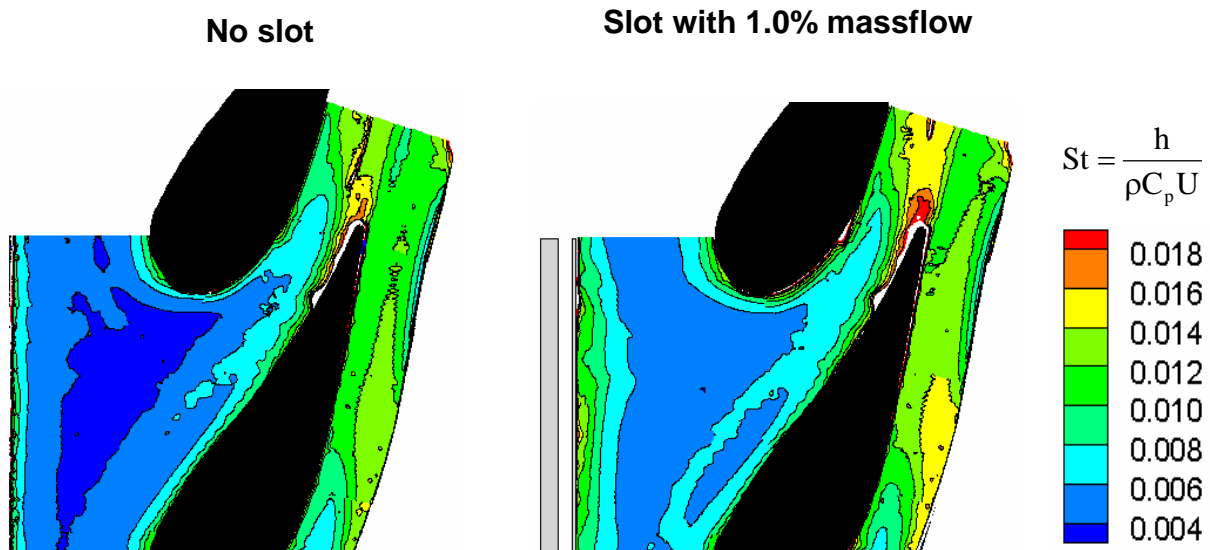

Figure 2. Measurements of convective heat transfer coefficients for a turbulent boundary layer (left) and an incoming more realistic combustor exit flow (right).

## RESPONSE OF SEPARATION BUBBLE TO VELOCITY AND TURBULENCE WAKES

J. Hourmouziadis and G. Hofmann

Jet Propulsion Laboratory, Aerospace Institute, Berlin University of Technology  
Berlin, Germany

The effects of profile wakes on downstream blade rows have been studied extensively in the past several decades. Such flows consist of a velocity defect and a turbulence wake. Due to their nature these two characteristics have a different influence on the downstream boundary layer. Experiments have been performed in a low speed facility with a superimposed pressure distribution on a flat plate similar to that on the suction surface of a turbine blade generating a typical transitional separation bubble. High resolution hot wire measurements were carried out. The velocity and the turbulence wake were separated into a periodic low turbulence flow and a constant velocity flow with periodic turbulence by means of appropriate experimental setups. Steady flow results have been obtained with varying main flow turbulence levels.

Earlier experiments in periodic flow indicated that there is a phase shift between the external flow and the fluctuations of the separated shear layer. It was confirmed that this is due to the transition process which is effected both from periodicity and turbulence.

The measurements in steady flow permitted a detailed analysis of the mixing process during transition and reattachment. An evaluation method was developed using the skewness of the velocity signal. It could be shown that mixing takes place in both sides of the separated shear layer, into the dead water zone and into the main flow. Consequently the resulting thickness after reattachment increases with the thickness of the separation bubble. An assessment of losses from downstream momentum thickness showed a clear correlation which appears to be independent of main flow turbulence and Reynolds number.

Main flow turbulence has a considerable effect within the stable laminar boundary layer far upstream of separation and transition, starting practically at the leading edge. The velocity fluctuations near the wall are stronger than those in the main flow. This phenomenon, often observed in unsteady flow with passing wakes, is obviously also present in steady flow with high main flow turbulence. It is similar to DNS simulation results (Jacobs and Durbin 2000) and could have something to do with the receptivity response of the boundary layer.

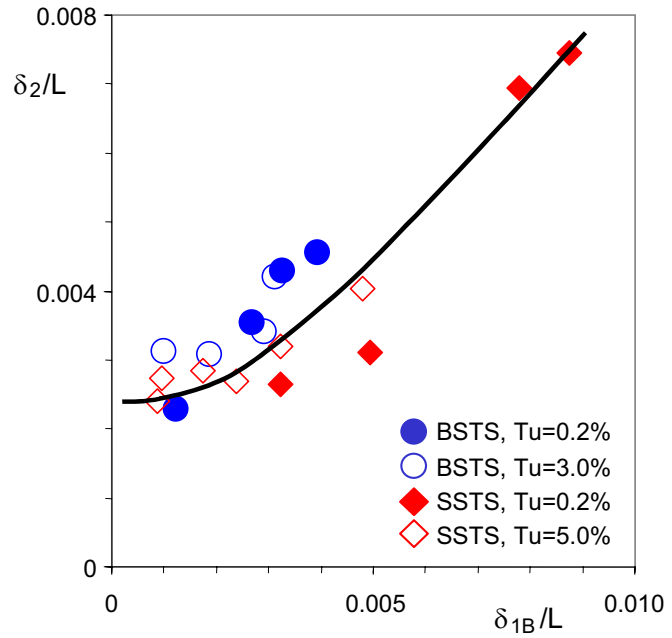
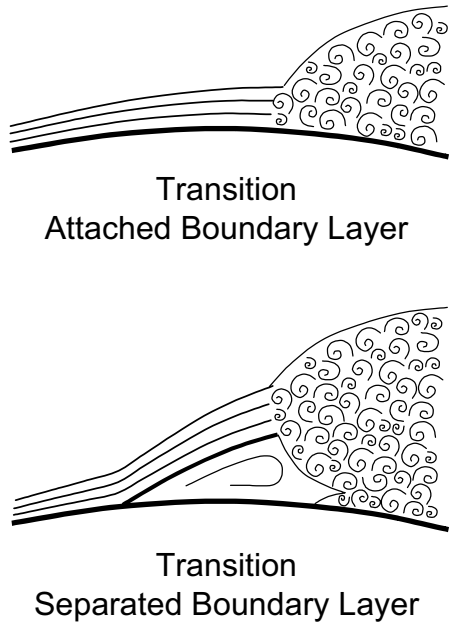

Separation Bubble Transition Characteristics

Effect of Bubble Thickness on Losses

BSTS = Blowing Side Test Section

SSTS = Suction Side Test Section

$\delta_2$  = Momentum Loss Thickness

$\delta_{1B}$  = max Bubble Displacement Thickness

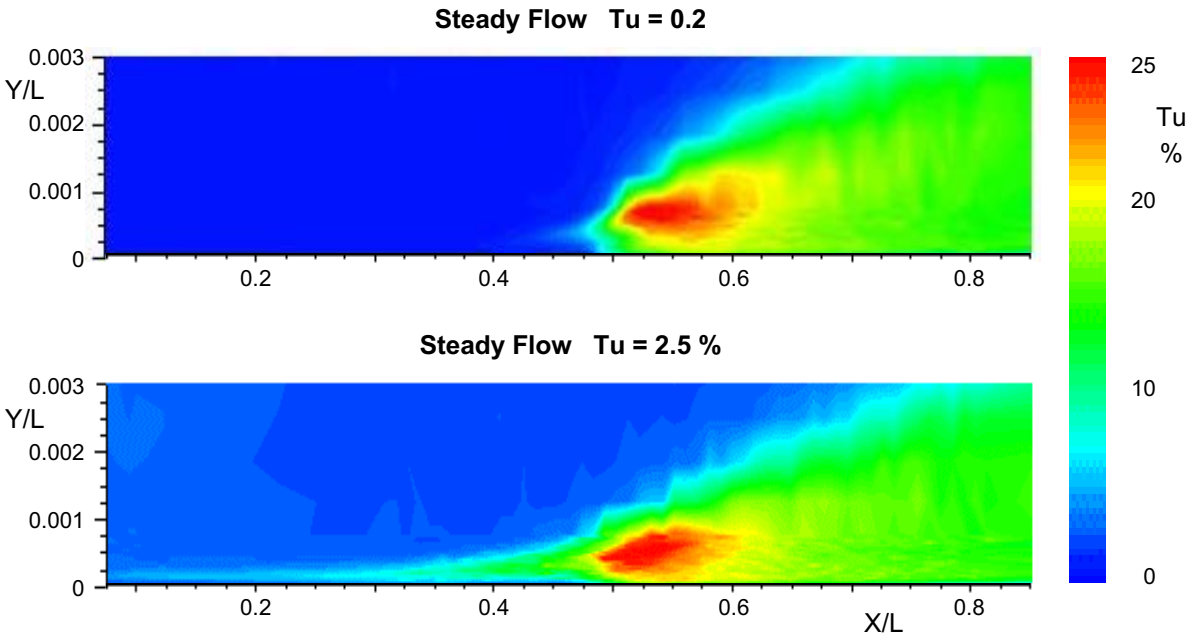

Effect of External Flow Turbulence on the Laminar Boundary Layer

# UNSTEADY TRANSITION AND SEPARATION IN AN LPT CASCADE

Jeffrey Bons  
Brigham Young University  
Salt Lake City, UT

## Introduction

Boundary layer separation can be a significant detriment to turbine stage performance if the separation bubble does not reattach before the trailing edge of the blade. Laminar to turbulent boundary layer transition plays a critical role in determining separated shear layer development and potential reattachment. Flow control experiments using pulsed vortex generator jets (VGJs), have demonstrated substantial reductions in LPT separation losses<sup>1</sup>. The control mechanism for pulsed VGJs appears to be some combination of unsteady transition and vortical effects. The present study explores some of the differences between unsteady VGJ implementation with reattaching (closed) and non-reattaching (open) separations. Phase-averaged and time-resolved flow measurements were made for both a mid-loaded (L1M) and an aft-loaded (Pack B) LPT blade profile at low Reynolds numbers.

## Experimental Facility

Two blade profiles were used in the current study, the L1M (designed by AFRL<sup>2</sup>) and the Pack B (a Pratt-Whitney research design). The 3 blades in the linear cascade have an axial chord ( $c_x$ ) of 0.22m and a span of 0.38m. The L1M solidity (axial chord/spacing) is 0.99 with a design Zweifel load coefficient of 1.34, while the Pack B solidity and Zweifel coefficient are 1.13 and 1.15 respectively. Due to its mid-loaded design, the L1M has a closed separation bubble at least down to  $Re_c = 20,000$ . The Pack B is fully separated at this same operating condition. PIV data were acquired with pulsed control ( $B_{max} \cong 1.7$ ) at a frequency of 5 Hz with a duty cycle of 25%. Large data records were also acquired with a hot-film to insure steady statistics for calculating transition parameters<sup>3</sup>.

## Results

Figure 1 shows an iso-velocity contour identifying the extent of the separation bubble shortly after the jet pulse has been initiated on the L1M blade. The sawtooth pattern at the bubble upstream edge indicates an unsteady reattachment line that gradually merges into a spanwise uniform disturbance as the bubble is pushed off the trailing edge of the blade by the disturbance (Fig. 2). Time-resolved hot-film measurements taken in a plane located two VGJ hole diameters from the injection location (and in the path of the jet) show that this sawtooth pattern is marked by boundary layer transition caused by the VGJs. Figure 3 shows a time-space plot of velocity fluctuations ( $u_{rms}/U_{in}$ ) taken 7mm from the blade surface using the hot-film in the plane indicated above. A region of elevated turbulence convects downstream from the VGJ injection location (50% axial chord on the L1M) moving at roughly 70% of the local freestream velocity. Corresponding intermittency plots show this to be a region of transitional/turbulent flow. After the jet event has passed, the transition location temporarily moves downstream of its uncontrolled location (identified by a yellow band in Fig. 3), creating a calmed region of boundary layer fluid similar to what has been described by others following a wake-passing<sup>4</sup>. The calmed region gradually disappears as the separation bubble grows prior to the arrival of the next jet pulse. A notable difference between the L1M and the Pack B separation bubbles is the time constant associated with bubble growth after the jet disturbance has passed. Figure 4 shows the integrated separation bubble area as a function of time over one pulsing cycle. In this plot, the integrated separation size is normalized by the separation bubble size without control ( $B=0$ ) for both the L1M and Pack B cases. The L1M

(reattaching) bubble grows linearly to its uncontrolled state immediately after the passing of the jet disturbance, while the Pack B (non-reattaching) bubble has a substantial phase lag, or period of zero net change (phases 16-22) before growth resumes. This phase lag response has been noted before in a larger Pack B linear cascade facility<sup>1</sup> and suggests that a massively separated blade could be adequately controlled with short bursts injected at a frequency equal to the phase lag response.

**References**

[1] Bons, J. P., Sondergaard, R., and Rivir, R. B., “The Fluid Dynamics of LPT Blade Separation Control Using Pulsed Jets,” *ASME Journal of Turbomachinery*, Vol. 124, Jan. 2002, pp. 77-85.  
 [2] Bons, J. P., Hansen, L. C., Clark, J.P., Koch, P.J., and Sondergaard, R., 2005, “Designing Low-Pressure Turbine Blades with Integrated Flow Control,” *IGTI 2005*, GT2005-68962.  
 [3] Bons, J.P., Bloxham, M. and Reimann, D., 2006, “Separated Flow Transition on an LP Turbine Blade with Pulsed Flow Control,” *IGTI2006*, GT2006-90754.  
 [4] Gostelow, J.P., and Thomas, R.L., 2003, “Response of a Laminar Separation Bubble to an Impinging Wake,” *IGTI2003*, GT2003-38972.

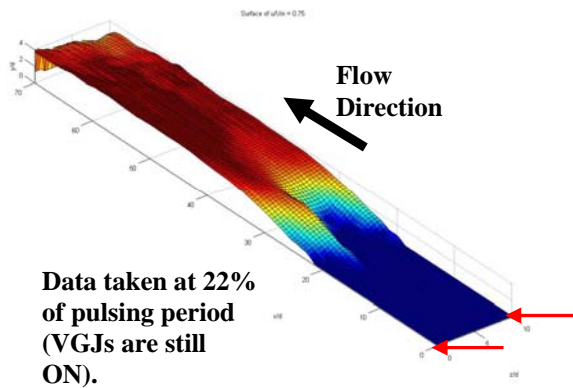

Figure 1: Iso-velocity surface ( $u/U_{in} = 0.75$ ) identifying region of separated flow for L1M. VGJ locations shown with red arrows.

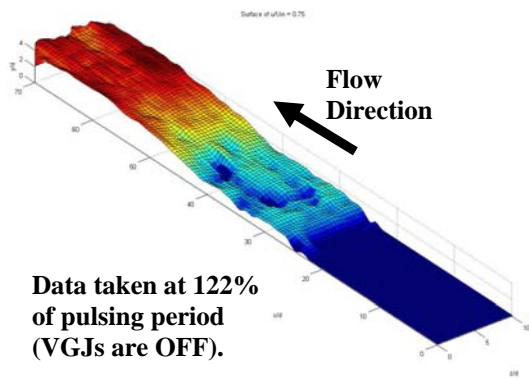

Figure 2: Iso-velocity surface ( $u/U_{in} = 0.75$ ) identifying region of separated flow for L1M.

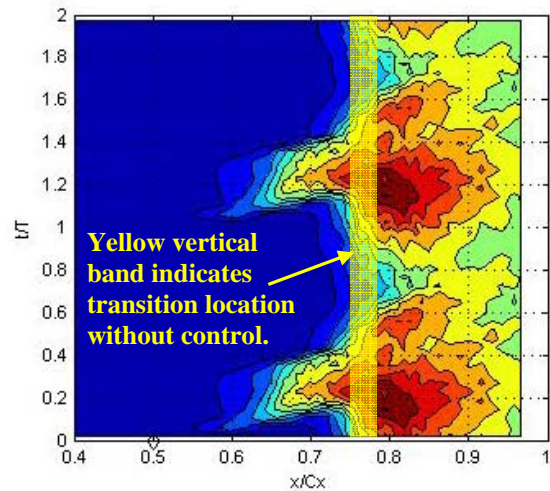

Figure 3:  $u_{rms}/U_{in}$  time-space plot for L1M at  $y/c_x = 0.033$  from blade surface.

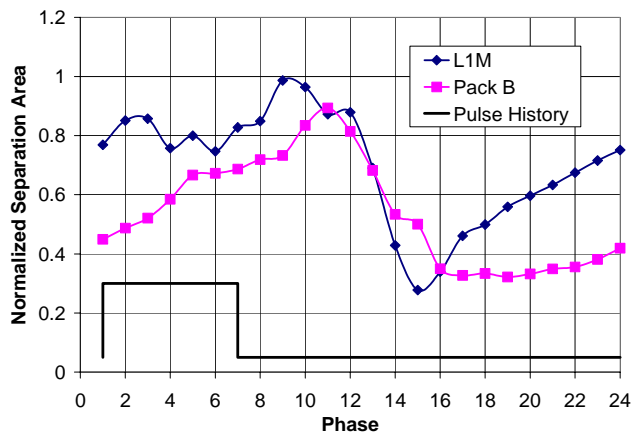

Figure 4: Normalized separation bubble size vs. pulsing phase for L1M and Pack B



## WAKE INTERACTIONS AND THE PERVASIVE INFLUENCE OF THE CALMED REGION

J.P. Gostelow, R.L. Thomas, and D. Adebayo  
University of Leicester  
Leicester, U.K.

Transition and separation phenomena occurring in axial flow compressors are simulated on a larger scale to provide further evidence on the similarities between turbomachinery and wind tunnel flows. A flat plate with a long laminar separation bubble, caused by a strong adverse pressure gradient, was subjected to wakes generated by rods moving transversely upstream of the leading edge. Wakes were originally presented individually. Each individual wake provoked a vigorous turbulent patch, resulting in the instantaneous collapse of the separation bubble. This was followed by a very strong, and stable, calmed region.

Following the lead given by the experiments of Gutmark and Blackwelder on triggered turbulent spots, wakes were then presented in pairs at different wake spacing intervals; in this way it was proposed to investigate wake interaction effects in more detail. As in the work on triggered turbulent spots the spacing between impinging wakes was systematically varied; it was found that for close wake spacings the calmed region acted to suppress the turbulence in the following turbulent patch.

To investigate whether this phenomenon was a recurring one, or whether the flow then reverted back to its unperturbed state, the experiments were repeated with four rods instead of two. The variables encompassed a wide range of variables including direction and speed of rod rotation. It was found that the subsequent wakes were also suppressed by the calming effect. This repeating situation may also be anticipated in a turbomachine, resulting in benefits for efficiency, stall margin and heat transfer.

EFFECTS OF FREESTREAM TURBULENCE AND  
STREAMWISE PRESSURE GRADIENT ON THE  
SUBSTRUCTURES OF TURBULENT SPOTS

Metin I. Yaras  
Department of Mechanical and Aerospace Engineering  
Carleton University  
Ottawa, Canada

Accurate prediction of laminar-to-turbulent transition of boundary layers is critical to the aerodynamic design and analysis of turbomachinery blades that are continually optimized for increased loading. The prediction of the transition process consists of quantifying the streamwise location of transition onset and the streamwise length that is required to reach a fully-turbulent state, with the latter often being dictated by the rates of production, convection and spreading of turbulent spots. It is important to understand the internal structure of turbulent spots, for this relates to the way the spot interacts with the surrounding laminar boundary-layer fluid thus dictating its spreading rate, and also determines the way we should calculate the time-averaged boundary-layer properties in the transition zone.

In the current work, experimental results on the internal flow structure of turbulent spots are presented, and the sensitivity of this structure to streamwise acceleration rate and freestream turbulence is examined. Measurements were performed on a flat plate, with two variations of freestream acceleration rate and three levels of freestream turbulence. The turbulent spots were generated artificially at a fixed distance from the test-surface leading edge, and the development of the spot was documented through hotwire measurements.

The results demonstrate the presence of a streaky structure of streamwise velocity in the turbulent spot, with high- and low-velocity streaks following an alternating pattern in the spanwise direction, the turbulent spot being consistently terminated by a low-velocity streak at the wingtip, and the high-velocity streaks residing closer to the wall than the low-velocity streaks. This pattern provides strong support for the presence of hairpin-like vortices that are spread through the turbulent spot in a well-organized pattern. Based on the sensitivity of the streaky pattern to the freestream streamwise rate of acceleration, the spanwise meandering of the streaks in the turbulent spot is argued to decrease with increasing streamwise acceleration. The spanwise spacing of the streaks is found to be somewhat higher than those observed in the inner region of turbulent boundary layers, and this difference is argued to be the result of the stabilizing influence of strong favorable streamwise pressure gradients. The favorable agreement between the present trends in the streaks of the turbulent spots and of those measured in the inner region of turbulent boundary layers, with respect to the sensitivity of their spanwise meandering and spanwise spacing to streamwise acceleration, is suggestive of a fundamental

similarity between the coherent hairpin-like vortical structures in transitioning and turbulent boundary layers.

The magnitude of the velocity perturbations associated with the streaky structure is observed to decrease with increasing freestream turbulence. This is accompanied by considerable increase in the spanwise meandering of the streaks. In the present instance, the integral length scale of the freestream turbulence eddies that are responsible for the noted trends are of the same order of magnitude as the spanwise spacing of the streaks in the turbulent spot. Despite the noted effect of freestream turbulence on the internal structure of the turbulent spot, its effect on the transverse spreading and streamwise convection rates of the spot were observed to be insignificant over the measured range of freestream turbulence levels. This result is suggested to be at least partly due to the stabilizing influence of the strong favorable streamwise pressure gradients on the laminar boundary layer.

Finally, through comparison of the present results with published literature, the streamwise direction of the arrowhead shape of the turbulent spot is shown to depend on whether the disturbance is introduced near the wall or near the edge of the boundary layer. In the instance where the disturbance is introduced across the thickness of the boundary layer, as in the present study, the scenario associated with a boundary-layer-edge disturbance is observed to dominate.

## TRANSITIONS ON SWEEPED LEADING EDGES

P.R. Viswanath,<sup>1</sup> R. Mukund,<sup>1</sup> **Roddam Narasimha**,<sup>2</sup> A. Prabhu,<sup>3</sup>  
J.D. Crouch<sup>4</sup>

<sup>1</sup>National Aerospace Laboratories, Bangalore, India

<sup>2</sup>Jawaharlal Nehru Centre for Advanced Scientific Research, Bangalore, India

<sup>3</sup>Indian Institute of Science, Bangalore, India

<sup>4</sup>Boeing Commercial Airplanes, Seattle, WA

This presentation covers two experimental investigations inspired by problems in external aerodynamics (specifically swept wings) but relevant, we believe, to situations in internal aerodynamics as well (effects of convex curvature and sweep on leading edge flows).

The first investigation concerns the effect of convex surface curvature on a flow that is relaminarizing under the influence of high favourable pressure gradients. It is well known that, at sufficiently high sweep angles and Reynolds numbers, the attachment line boundary layer at a leading edge can be turbulent because of contamination from fuselage or end wall. This turbulent boundary layer encounters large favourable pressure gradients on a surface with high streamwise convex curvature. Detailed experiments were conducted on two flows – one on a convex surface and the other a flat surface – both supporting virtually identical pressure distributions in terms of the Launder acceleration parameter  $K$ . The maximum value of  $K$  is  $6.2 \times 10^{-6}$ , well above the usually advocated critical value for relaminarization of about  $3.5 \times 10^{-6}$ . The spatial extent of the acceleration zone is about 11 initial boundary-layer thicknesses, appreciably shorter than in earlier work in order better to simulate conditions at the leading edge of a typical aircraft wing. The fall in skin friction coefficient is steeper and the rise in shape factor sharper on the convex surface (flow CP1) compared to the flat surface (flow FP1), indicating that relaminarization on the convex surface is both more rapid and more nearly complete (Figure 1). In the crucial relaminarizing zone, the two-layer quasi-laminar theory of Narasimha & Sreenivasan (1973) is found to predict the convex-surface mean-flow parameters more accurately than the flat-surface flow, without any explicit modelling of curvature effects. Thus, experimental results and supporting calculations both indicate that the dominant effect of streamwise convex curvature on the mean flow is to promote more rapid and complete relaminarization in an accelerated turbulent boundary layer, thus enhancing the probability of its occurrence on swept leading edges where both factors are significantly in operation.

The second investigation concerns what appears to be multiple transitions in the leading edge region of a swept wing. Experiments on a wing of  $60^\circ$  sweep at an angle of attack of  $18^\circ$  show three distinct minima within the first 10% of the chord in the rms value of signal from surface hot film gauges and in an intermittency coefficient (Figure 2). Qualitatively similar but weaker variations are seen at lower angles of attack and on other wings tested in the experiments. Based on an analysis of the variation of pressure gradient, curvature and Reynolds number in these flows, it is proposed that the most direct interpretation of the observations is that there is a sequence of transitions in the flow, from laminar to turbulent, reverting towards laminar, back again towards turbulent etc. In the case mentioned six such transitions, not all of them complete, can be identified. Such 'transition cycles' may account for variations in maximum lift coefficient obtained or maximum loading on a turbomachinery airfoil.

---

<sup>†</sup> Supported by Boeing Commercial Airplanes, Seattle, WA, USA, and Defence Research & Development Organization, New Delhi.

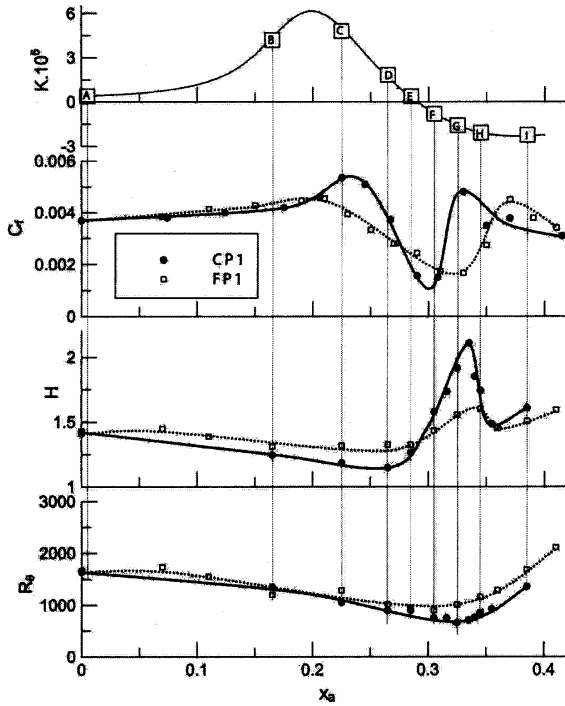

Figure 1

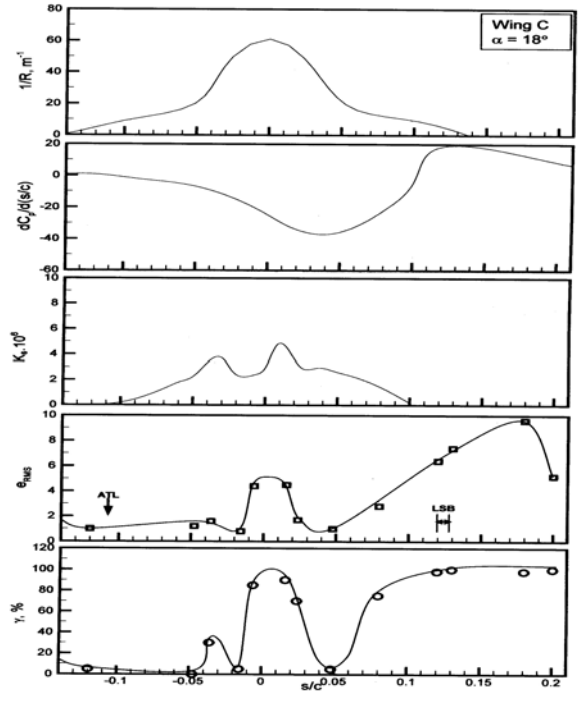

Figure 2

**References**

Narasimha R, Sreenivasan K R 1973 *J. Fluid Mech.* 61:417-447.

Mukund R, Viswanath P R, Narasimha R, Prabhu A, Crouch J D 2006 *J. Fluid Mech.* (to appear)

Narasimha R 2006 *Proc. IUTAM Symp. One Hundred Years of Boundary Layer Research*, Springer (Eds. GEA Meier, K R Sreenivasan), pp.145-154.

Viswanath P R, Mukund R, Narasimha R, Crouch J D 2004 *AIAA Paper* 2004-99.

Viswanath P R, Mukund R, Narasimha R, Crouch J D 2006 To appear in *AIAA J.*

# LINEAR INSTABILITY OF THE FLOW PAST A LOW PRESSURE TURBINE BLADE

Vassilis Theofilis  
School of Aeronautics, Universidad Politécnica de Madrid  
Madrid, Spain

Nadir Abdessemed and Spencer J. Sherwin  
Department of Aeronautics, Imperial College London  
London, U.K.

The present work is concerned with linear BiGlobal instabilities of flow in a cascade of Low-pressure turbine (LPT) blades. In particular the three-dimensional instability of two-dimensional *steady* and *time-periodic* basic states past a T106/3 blade has been investigated a high-order spectral/hp-element scheme and BiGlobal linear theory. The two-dimensional bifurcation of steady to time-periodic flow has first been identified at  $Re_{2d,crit} \approx 905$ . It has been shown that, subcritically, three-dimensional flow is more stable than its two-dimensional counterpart.

Subsequently, Floquet analysis has shown that the time-periodic flow set up by linear amplification of the two-dimensional flow becomes three-dimensionally unstable soon after the two dimensional transition. Two modes of significance have been identified, associated to the separation bubble and the wake of the basic state. Three-dimensional DNS initialized on the identified Floquet eigenmodes at low amplitudes confirms the results of linear stability analysis. A narrow band of Floquet multipliers corresponding to unstable three-dimensional flow has been identified to exist and persist for all Reynolds numbers examined,  $10^3 < Re < 10^4$ . However, relaxation of the periodic boundary conditions imposed in the present blade-cascade model affects the linear (modal) instability identified.

First-ever transient-growth results of this essentially nonparallel flow have thus been obtained. In particular, the pseudo-spectrum of the flow under consideration has been identified and new mechanisms have been revealed, demonstrating the potential for three-dimensional transition as consequence of transient growth. The identified phenomenon already exists subcritically to  $Re_{2d,crit}$ ; given the quadratic dependence of the gain on Reynolds number, it is expected to persist in the Reynolds number of interest to applications. Further work to quantify the transient growth phenomenon is underway.

**Fig 1.** Amplitude function of the spanwise (3D) disturbance velocity component of the BiGlobal eigenmode of 2D separation bubble flow. Left-to-right: adverse-pressure gradient flat plate flow, steady flow in the trailing-edge of a NACA 0012 airfoil at an angle of attack, steady flow on the trailing-edge of a T-106/300 LPT blade, time-periodic flow on the trailing-edge of a T-106/300 LPT blade

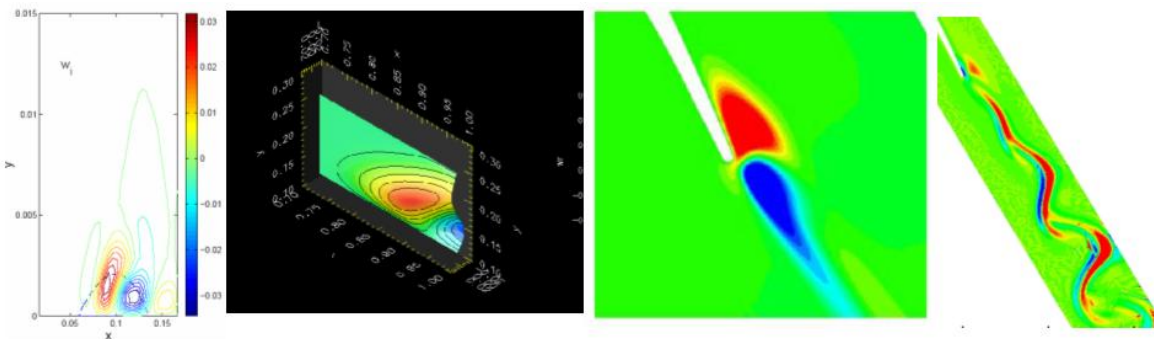

The material is based upon work sponsored by the Air Force Office of Scientific Research, Air Force Material Command, USAF, under Grant number F49620-03-1-0295 to *nu modelling s.l.*, entitled “Global instability and control of low-pressure turbine flows”. The Grant was initially monitored by Dr. Thomas Beutner (now at DARPA) and subsequently by Lt. Col. Dr. Rhett Jefferies of AFOSR. The views and conclusions contained herein are those of the author and should not be interpreted as necessarily representing the official policies or endorsements, either expressed or implied, of the Air Force Office of Scientific Research or the U.S. Government.

NUMERICAL INVESTIGATION OF ACTIVE CONTROL  
FOR LOW-PRESSURE TURBINE BLADES

H.F. Fasel, W. Balzer, and A. Gross  
Department of Aerospace and Mechanical Engineering  
University of Arizona  
Tucson, AZ

Low-pressure turbine (LPT) stages are a common element of many modern jet engines. When operating conditions are detrimental or when more aggressive designs are considered, laminar separation from LPT blades can occur resulting in considerable performance losses. Several years ago it was shown by Rivir and coworkers<sup>1-3</sup> at the Air Force Research Laboratory (AFRL) that active flow control (AFC) by vortex generator jets (VGJs) can significantly reduce the losses induced by laminar separation. Pulsed VGJs were found to be considerably more effective than steady VGJs. Steady blowing was shown to generate streamwise vortices (similar to conventional vortex generators) whereas pulsed blowing was shown to result in early boundary layer transition. Recently Bons et al.<sup>4</sup> demonstrated that more aggressive LPT designs become possible when considering AFC from the very beginning.

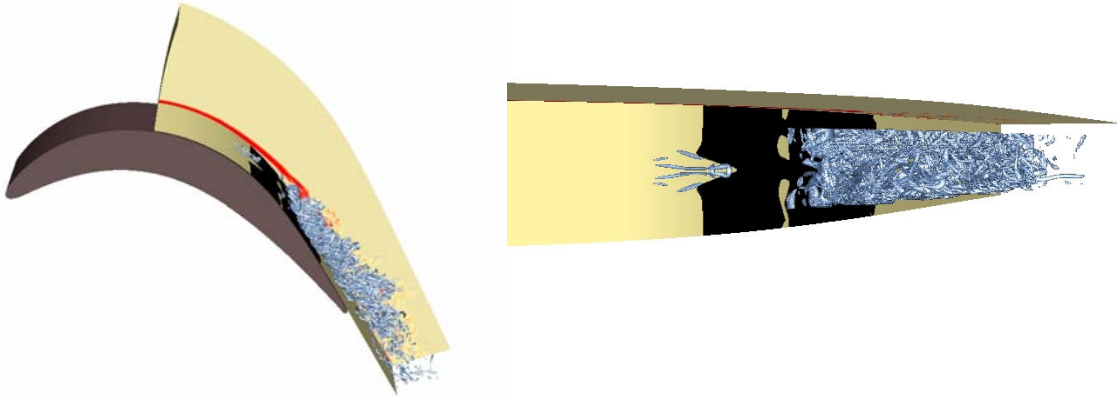

**Fig. 1: LPT flow controlled by pulsed VGJs. Iso-surface of  $\lambda_2$  vortex identification criterion. Computational domain indicated by beige box, iso-contour lines of spanwise vorticity in red. Side-view (left) and top down view (right). VGJ actuation results in early flow transition.**

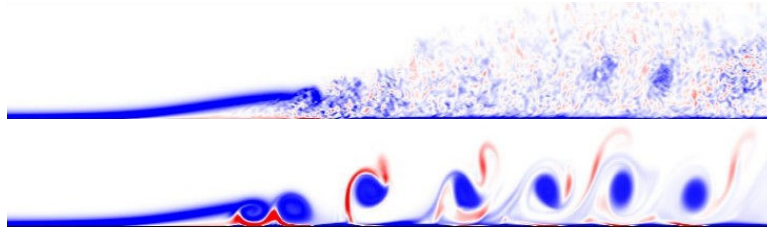
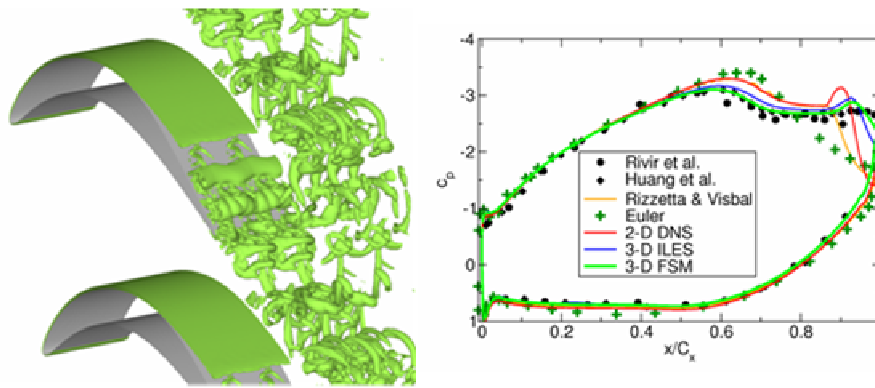

**Fig. 2: DNS of laminar separation bubble on flat-plate. Iso-contours of spanwise vorticity. Unforced flow (top) and controlled flow (bottom). Harmonic excitation of 2-D mode at right frequency relaminarizes flow.**

We are currently performing high resolution direct numerical simulations (DNS) where the computational domain has the same curvature and the flow is subjected to the same wall pressure distribution as in the PakB experiments at AFRL (R. Sondergaard, R. Rivir) and Brigham Young University (J. Bons). The comparison with earlier investigations, where we investigated AFC by VGJs for a generic flat-plate model, will help us determine the effect of flow curvature. A typical result for the curved geometry with pulsed VGJs and a duty cycle of 10% is shown in Fig. 1. As for the flat plate geometry, the pulsed VGJ

actuation leads to the formation of hairpin like vortices that initiate a “Bypass” transition of the flow. For the specific operating parameters considered here the transitional flow shows little coherence. A broader parameter range has to be explored before a definitive statement about the relevant physical mechanisms for separation control by pulsed VGJs for the curved geometry can be made.

We also investigated secondary instability mechanisms in both forced and unforced laminar separation bubbles. By employing a local stability analysis of a spatially periodic baseflow, we were able to show that the unforced laminar separation bubble can exhibit a strong secondary absolute instability with respect to three-dimensional disturbances resulting in a rapid transition to turbulence (Fig. 2, *top*). Based on our analytical analysis we determined that by introducing a large amplitude high frequency 2-D disturbance shortly upstream of the separation the growth rates of the 3-D mode could be reduced significantly. This finding was supported by 3-D DNS results. Figure 2 (*bottom*) shows that the flow can be kept laminar over a substantial downstream distance. These preliminary results indicate that secondary absolute instability mechanisms play a relevant role in the transition process for laminar separation bubbles and transition control by AFC appears to be possible for LPT applications.



**Fig. 3: FSM of linear PakB LPT cascade. Instantaneous visualization of  $Q$  vortex identification criterion (*left*) and computed wall pressure coefficient (*right*).**

In parallel with the experiments by Rivir and co-workers at AFRL we also carried out numerous two- and three-dimensional simulations of a linear PakB LPT cascade at  $Re=25,000$ . Most of these earlier results should not be considered DNS, but rather ILES, since the simulations did not resolve all scales of turbulent motion. Lately we began employing our flow simulation methodology (FSM) for lowering the computational requirement. FSM is a hybrid turbulence modeling approach that is locally and temporally RANS, LES, or DNS depending on the local grid resolution and the instantaneous turbulence characteristics. Results obtained with our FSM for the PakB LPT blade are shown in Fig. 3. The pressure distribution computed with FSM is in very good agreement with the experimental data. Grid resolution studies and a more detailed comparison of the computed flow data with the measurements will allow us to further validate and enhance the FSM approach.

1. Bons, J.P., Sondergaard, R., and Rivir, R.B., “Turbine Separation Control Using Pulsed Vortex Generator Jets,” ASME Journal of Turbomachinery, Vol. 123, No. 2, pp. 198-206, 2001.
2. Bons, J.P., Sondergaard, R., and Rivir, R.B., “The Fluid Dynamics of LPT Blade Separation Control Using Pulsed Jets,” ASME Journal of Turbomachinery, Vol. 124, No. 1, pp. 77-85, 2002.
3. Sondergaard, R., Bons, J.P., and Rivir, R.B., “Control of Low-Pressure Turbine Separation Using Vortex Generator Jets,” Journal of Propulsion and Power, Vol. 18, No. 4, pp. 889-895, 2002.
4. Bons, J.P., Hansen, L.C., Clark, J.P., Koch, P.J., and Sondergaard, R., “Designing Low-Pressure Turbine Blades with Integrated Flow Control,” Proceedings of GT2005, ASME Turbo Expo 2005: Power for Land, Sea, and Air, June 6-9, 2005, Reno-Tahoe, NV.



# TURBINE BLADE TIP CLEARANCE FLOW CONTROL USING PLASMA ACTUATORS

Travis C. Douville, Julia Stephens, Daniel K. Van Ness,  
Thomas C. Corke, and Scott C. Morris  
University of Notre Dame  
Center for Flow Physics and Control  
Aerospace and Mechanical Engineering Department  
Notre Dame, IN

## ABSTRACT

The over-tip leakage flow remains a primary source of energy loss for axial flow turbine blades, limiting the amount of useful work to be extracted by the turbine and thus the efficiency of the turbomachine. Noting the industrial, commercial, and military implications to improved gas turbine engine efficiency and reliability, active and passive flow control techniques have been pursued to minimize loss on the blades.

Two linear cascade facilities have been developed at the University of Notre Dame to study the flow field in the tip gap region of turbine blades. Both of the facilities use Pratt & Whitney Pak-B blade shapes to simulate the pressure distribution of a generic low-pressure turbine stage. One facility has 11 blades that are a high aspect ratio of 4.5. The Reynolds numbers based on axial chord for conditions used in this facility range from 10,000 to 100,000. The other facility is designed to examine higher velocities and Reynolds numbers. It consists of three blades (2 passage) that have a low aspect ratio of 0.96. Typical Reynolds numbers range from 100,000 to 500,000, corresponding to Mach numbers of 0.1 to 0.33.

In both cases, the center blade in the cascade is cantilevered to provide an unobstructed gap between the blade tip and end wall on the unsupported end. The gap-to-chord ratio of the center blade in the two facilities can be varied from 0 to 5 percent. Blade pressure distributions at midspan and tip of the cantilevered blade are measured with static pressure ports on the surface. Additionally, pressure taps are located on the tunnel wall under the blade tip. A 5-hole Pitot probe carried on a 2-D traverse system is used to study the flow downstream of the blades. This is used to obtain aerodynamic loss coefficients and three dimensional velocity vectors in a matrix of points along the blade edge and across blade wake, with particular focus on the gap region.

Examples of the measurements made in the wake of a blade with a 4%  $g/c$  ratio at a Reynolds number of 500,000 are shown in Figures 1 and 2. This is based on measurements made with the 5-hole probe, one chord length downstream of the center blade, in the low aspect ratio facility. Figure 1 corresponds to the baseline flow. The top plot shows contours of constant vorticity and the corresponding velocity vectors. The dashed curves corresponds to the  $-\lambda_2$  contours of the vorticity, which is an indication of the location of streamwise vortices associated with the tip-gap and passage vortices, respectively. The bottom plot shows contours of constant loss coefficient. The peak loss coefficients are encircled by the  $-\lambda_2$  contours, indicating that the tip-gap and passage vortices are primarily responsible for the flow losses.

Figure 2 shows the same basic conditions as Figure 1, except with the addition of a “partial squealer tip” on the end of the blade. The gap-to-chord ratio at the squealer tip is 2.5%. The effect of the squealer tip is to noticeably reduce the vorticity and losses associated with the tip vortex.

The passive squealer tip was used to provide a baseline to active flow designs based on plasma actuator concepts. The plasma actuators were placed on the end of the blade. An example of the plasma actuator used on the blades is shown in Figure 3. The actuator consists of two electrodes, one exposed to the air and the other covered by a dielectric insulator. A high voltage a.c. causes the air over the covered electrode to ionize. The ionized air (plasma) in the presence of the electric field vector produced by the electrode geometry results in a body force that acts on the ambient flow. The body force vector for the

geometry in Figure 3 is indicated by the arrows. This is intended to oppose the flow through the tip-wall gap.

Rather than producing a steady blockage like the squealer tip, the plasma actuators were operated with an unsteady frequency that was meant to couple with instabilities inherent to the tip-gap flow. The results indicated frequency sensitivity that scales with the free-stream speed and gap dimension. At higher Reynolds numbers, the plasma actuators resulted in a decrease in the loss coefficient. The advantage of these over the squealer tip is that they are flush to the blade tip surface and therefore not prone to damage due to rubs or heating.

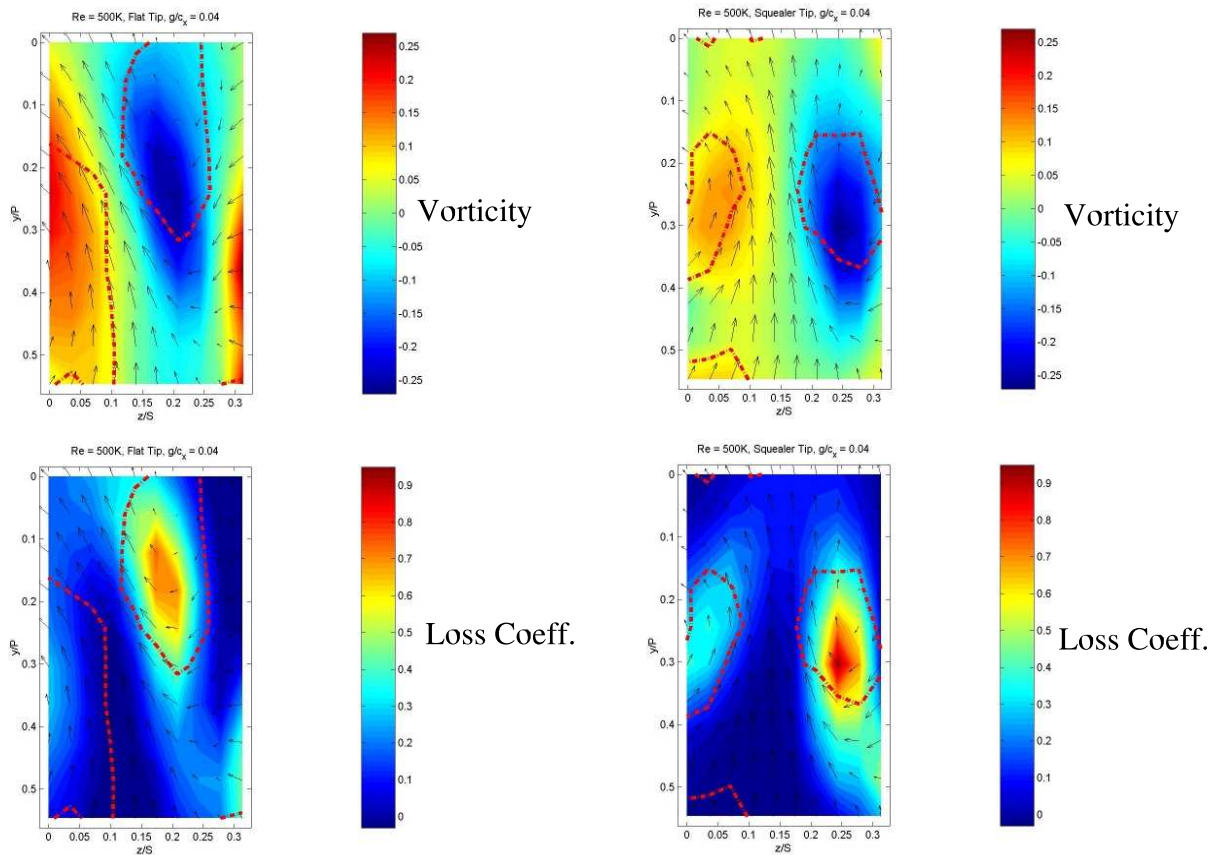

Figure 1. Baseline vorticity (top) and loss coefficient (bottom) contours for 4%  $g/c$  at  $Re = 500,000$ .

Figure 2. Vorticity (top) and loss coefficient (bottom) contours for 2.5%  $g/c$  squealer tip at  $Re = 500,000$ .

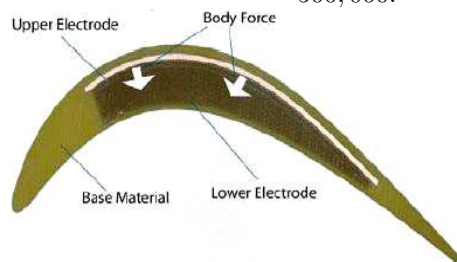

Figure 3. Plasma actuator configuration for tip-gap flow control. Actuator is located at the end of the blade on blade tip surface.

## TRANSIENT DISTURBANCES GENERATED BY QUASI-RANDOM SURFACE ROUGHNESS

Edward B. White, Robert S. Downs III, and Nicholas A. Denissen  
Department of Mechanical and Aerospace Engineering  
Case Western Reserve University  
Cleveland, OH

Recent experiments by White and coworkers<sup>1,2</sup> at Case Western Reserve University (Case) and by Fransson and coworkers<sup>3</sup> at the Royal Institute of Technology (KTH) in Stockholm have established that spanwise-periodic arrays of three-dimensional (3D) surface roughness elements excite steady boundary layer disturbances that undergo a transient period of algebraic energy growth followed by exponential decay. The flow downstream of the periodic roughness elements is composed of steady high- and low-speed streamwise streaks.

The Case and KTH experiments used spanwise roughness arrays to produce a disturbance field with a precisely controllable set of spanwise wavenumbers and a very clear disturbance origin. However, the ultimate interest of the ongoing work on roughness-induced transient disturbances is to provide information about behavior in more-realistic situations including disturbance behavior over fields of random roughness. In order to study this phenomenon in a well-controlled way that is suitable for comparison with numerical simulations, a technique has been developed to generate random roughness fields and to manufacture these fields using rapid prototyping technology. Fields are generated by randomly selecting amplitudes and phases of spatial Fourier modes of the surface roughness and limiting the longest spanwise mode so that the roughness is spanwise periodic on a period longer than any disturbance mode of interest. This periodicity has distinct signal processing advantages for the experiments and is also convenient for comparisons with numerical simulations that typically feature periodic boundary conditions. The roughness field is also tailored to provide other experimental advantages such as repeating flat sections that make accurate wall locating possible. Figure 1 shows the development of a roughness patch in 1D. Figure 2 shows the realization of a 6-mm-thick, 230 mm × 230 mm roughness sheet. The sheet includes seven identical roughness patches that measure 32 mm × 32 mm (including 4 mm of smooth surface between the patches). The steady wakes of the central five patches are measured; the outermost two patches are included to maintain spanwise periodicity.

Measurements of steady streamwise velocities have been performed using hotwire anemometers. The data show that the flow's response to the patches is spanwise-periodic, as expected, and that the data can be phase-lock averaged in span. Figure 3 gives an indication of the flow's distortion at the trailing edge of the roughness patches. Downstream of this point, the data show clear evidence of transient disturbance growth over the smooth portion of the surface downstream of the roughness patches with some disturbance wavelengths growing and others decaying. To date, three different freestream speeds have been investigated. At two lower speeds the roughness is subcritical and transition does not occur; at one faster speed the roughness is supercritical and transition occurs in the roughness elements' wakes.

---

\* This work is supported by the the U.S. Air Force Office of Scientific Research under grant number FA9550-01-1-0048.

## References

1. White, E.B. 2002. Transient growth of stationary disturbances in a flat plate boundary layer. *Phys. Fluids* 14(12):4429.
2. White, E.B., J.M. Rice and F.G. Ergin. 2005. Receptivity of stationary transient disturbances to surface roughness. *Phys. Fluids* 17:064109.
3. Fransson, J.H.M., et al. 2004. Experimental and theoretical investigation of nonmodal growth of steady streaks in a flat plate boundary layer. *Phys. Fluids* 16(10):3627.

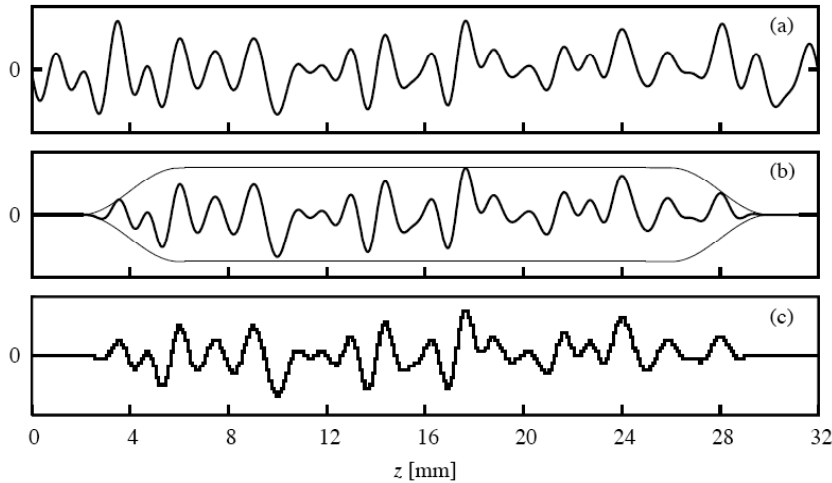

Figure 1. Surface patterns. A randomly generated surface (a); the random surface modified by the envelope function (b); a discretized realization of the random surface with a 100  $\mu\text{m}$  surface resolution (c).



Figure 2. A roughness sheet manufactured using the rapid prototyping approach. When mounted on the flat test plate, flow over this sheet moves from the bottom of the figure toward the top.

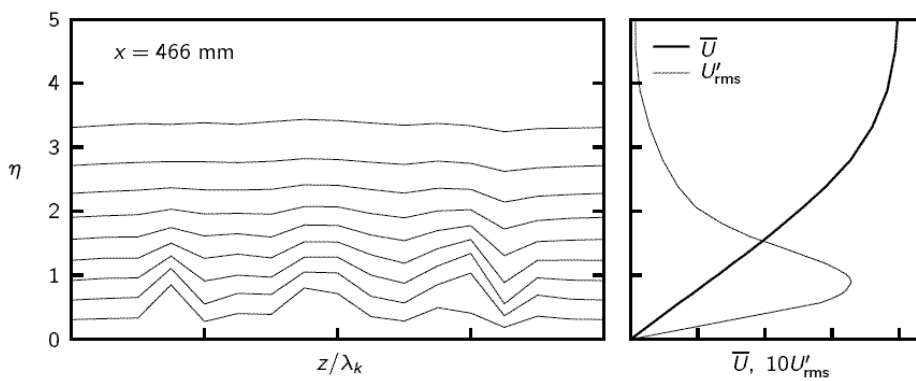

Figure 3. Steady streamwise velocity contours (left) and the  $U'_{\text{rms}}$  disturbance profile (right) at the roughness trailing edge.

EXPERIMENTAL AND NUMERICAL STUDY OF UNSTEADY AERODYNAMICS  
IN AN OSCILLATING LPT CASCADE

Damian M. Vogt and Torsten H. Fransson  
Department of Energy Technology  
KTH, Sweden

Hans E. Mårtensson  
Volvo Aero, Sweden

The unsteady aerodynamics during controlled blade oscillation in an annular sector cascade with low-pressure turbine (LPT) blades has been studied experimentally and numerically. Following an influence coefficient approach a cascade of seven blades has been employed with the middle blade made oscillating in controlled modes. One of the novelties of the presented study is the combination of three-dimensional flow and three-dimensional blade oscillation due to increasing bending amplitude from hub to tip as present for low-order structural modes. On the numerical side a linear Euler flutter prediction tool has been used at different degree of detailing. The influence coefficient technique is used in the experiments to transfer data to the traveling wave mode as well as to analyze the unsteady responses on the individual blades. The results indicate that the inviscid model is capable of capturing the main features of the unsteady aerodynamics during blade oscillation and that it can be used to support design work.

Figure 1 depicts profile sections of the low-pressure (LP) turbine profile used in the study at three spanwise heights as well as the test section. The profile features a real chord of 50mm at mid span and an aspect ratio (span/chord) of 1.94 at a radius ratio of 1.25. The blade is assembled in an annular cascade with cylindrical hub and casing contours at a pitch/chord ratio of 0.68 at mid span and a tip clearance of 1% span.

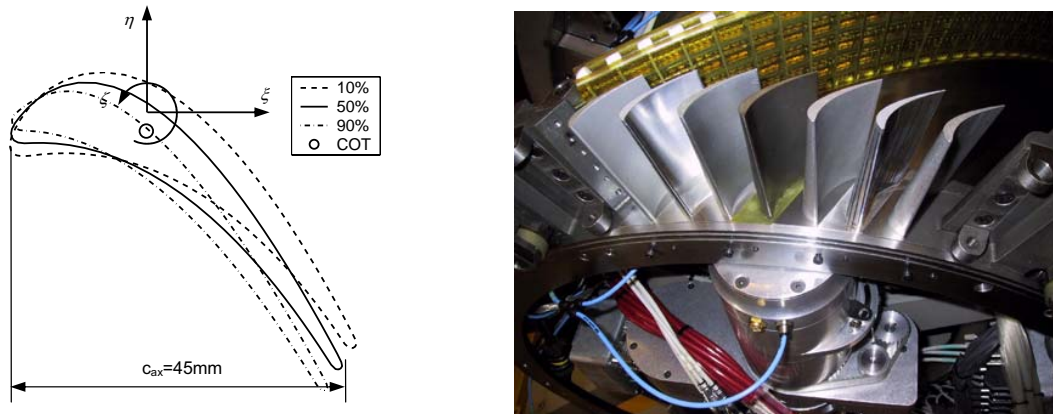
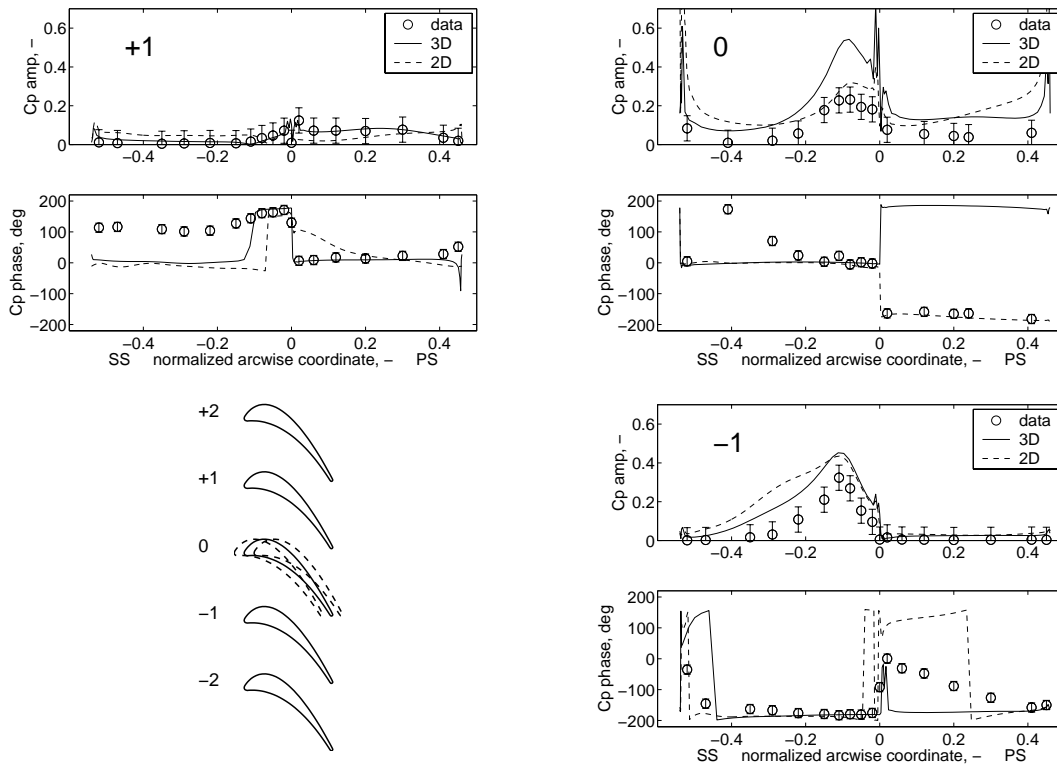

**Figure 1.** Test object (left) and test section (right)

Nominal inflow to the cascade was at -26deg yielding 87deg in turning. The reduced frequency has been varied during the tests by controlling the blade oscillation frequency. The reduced frequency is here based on full chord. A more complete description of the test case is presented in [12].

Figure 2 depicts comparisons of computed unsteady pressure obtained from the 2D and the 3D model without tip clearance to test data at midspan for the three middle blades. Data are plotted such that arc=0 is located at the blade leading edge whereas the negative branch is

spanning the suction side and the positive the pressure side respectively; the top part of the respective graph depicts the pressure amplitude while the pressure phase is included in the bottom part. It is recognized that the dominant part of unsteady pressure response is present on the oscillating blade (index 0) as well as the blade surfaces of the non-oscillating neighbor blades facing the oscillating blade (i.e. pressure side of blade +1 and suction side of blade -1).



**Figure 2.** Unsteady blade surface pressure at midspan; axial bending

Both models perform well by capturing the essential character of the unsteady flow; especially in regions of considerable pressure amplitude it is important to correctly capture the pressure phase in order to be able to accurately predict aeroelastic stability. Whereas the 2D model predicts the level of pressure perturbation more accurately around peak response (arc=0.11) the 3D model yields a qualitatively more accurate though overpredicted result.

Comparisons of the resolved unsteady blade surface pressure revealed superiority of the more complex model; although the 3D models were not always possible to capture the exact level of pressure perturbation it has been recognized that the overall characteristics of the unsteady flow during controlled blade oscillation could be predicted more accurately. From projections of pressure data onto the respective modes shapes locally resolved aeroelastic stability data were obtained. Correlations of numerical results and test data revealed a clear improvement when moving from the 2D model to the 3D model with tip clearance.

Given the limited though still satisfactory prediction accuracy of the 2D model it is concluded that the use of such models is justified for supporting preliminary design work, especially when assessing a large number of geometries. The gain in prediction accuracy has been demonstrated on the present test case when moving over a 3D model without tip clearance to a 3D model with tip clearance. For obtaining accurate results it is therefore concluded that the use of more complex models is inevitable.

## ACOUSTIC RESONANCE IN A HIGH-SPEED AXIAL COMPRESSOR

Joerg R. Seume  
Institute for Turbomachinery, Leibniz Universität Hannover  
Hannover, Germany

Non-harmonic acoustic resonances were detected in the static pressure and sound signals in a four-stage high-speed axial compressor, when the compressor was operating close to the surge limit. Based on literature research and measurements of the resonance frequency, Mach number of the mean flow, and the axial and circumferential phase shift of the pressure signal during resonance, it is shown that the acoustic resonance is an axial standing wave of a spinning acoustic mode with three periods around the circumference of the compressor. This phenomenon occurs only if the aerodynamic load in the compressor is high, because the mode needs a high circumferential Mach number for resonance conditions.

The phenomenon of acoustic resonance is explained with a simplified model for helical acoustic modes of ducts. It is shown that, for this concrete case mode scattering, vortices waves and mode trapping between the blade pitch could be left unconsidered. The remaining model considers the flow in the compressor as rigid body. The swirl is considered for the calculation of cut-off conditions. From the resonance frequency and mode shape it turns out, that wave fronts of the measured mode running against the swirl of the mean flow are close to cut-off. This means that they are trapped or reflected at axial positions where the swirl in the compressor is maximal, behind the rotor rows. The waves traveling with the swirl can propagate through the compressor over wide parts of the operating map. But at low mass flow, the waves cannot pass the stator rows anymore because their incidence angle is changing due to changing flow conditions in such a way that the waves hit the stator blades from the suction side instead of hitting them from the pressure side. This means that they are reflected by the blade rows and so all waves of the mode are trapped between the rotor and stator rows.

BLADE ROW INTERACTION RESEARCH AT THE AIR FORCE RESEARCH  
LABORATORY PROPULSION DIRECTORATE

Steven E. Gorrell, David Car, and Steven L. Puterbaugh  
Propulsion Directorate  
Air Force Research Laboratory  
Wright-Patterson Air Force Base, OH

Although it is known that the flow field in a turbomachine is unsteady, design tools do not explicitly account for it. The effects of varying axial gap on the unsteady flow field between the stator and rotor of a transonic compressor stage are important because they can result in significant changes in stage mass flow rate, pressure rise and efficiency. A consequence of relying on steady design tools is that the compression system does not always perform as predicted. It also leads designers to make incrementally small changes in designs to stay within the envelope of empirical experience. This makes it expensive and time consuming to develop and transition revolutionary technologies. Due to the trend toward increased relative Mach numbers and decreased axial spacing, it is important to understand how wake-shock interactions affect the performance of a transonic compressor. Conventional wisdom suggests that bow shocks which propagate upstream of a transonic blade row are weak and are not strong contributors to the performance of that blade row taken by itself. However, measured and numerical data shows that the rotor bow shock contributes to losses via blade row interactions when the axial distance between blade rows is sufficiently small. This is one of the technical challenges that must be overcome in order to develop highly loaded fans and compressors without sacrificing efficiency.

The Air Force Research Laboratory (AFRL) Compressor Aero Research Lab (CARL) has been conducting experimental and computational research on transonic compressor blade row interactions for some time. As reported in [1] the Stage Matching Investigation (SMI) rig test documented that the axial spacing between an upstream stator and downstream transonic rotor has a significant effect on stage performance. Mass flow rate, pressure ratio, and efficiency all decreased as the axial spacing between the wake generator and transonic rotor was reduced. This additional loss production occurs as a result of interaction between the upstream wake generator and downstream transonic rotor. Time-accurate simulations [2] of the SMI experiment revealed some important aspects of the production of this additional loss. At close spacing the rotor bow shock was chopped by the wake generator trailing edge and formed a pressure wave on the upper surface of the wake generator that propagated upstream until it weakened. The bow shock was oblique as it interacted with the wake generator trailing edge, but the resulting pressure wave that formed was turned more normal to the wake generator blade surface. The resulting moving shock produced an entropy rise. The magnitude of loss production was affected by the strength of the bow shock and how much it turned as it interacted with the trailing edge of the wake generator. At far spacing the rotor bow shock degenerated into a bow wave before it interacted with the stator trailing edge and



no significant pressure wave formed on the stator upper surface. For this condition, no additional loss was produced.

Details of the unsteady flow environment were analyzed with measurements using Digital Particle Image Velocimetry (DPIV) and with time-accurate simulations using the 3D unsteady Navier-Stokes CFD solver TURBO [3]. Generally there was excellent agreement between the measurements and simulations, instilling confidence in both. At close spacing vortices are shed from the trailing edge of the upstream stationary blade row in response to the unsteady, discontinuous pressure field generated by the downstream rotor bow shock. Shed vortices increase in size and strength and generate more loss as spacing decreases, a consequence of the effective increase in rotor bow shock strength at the stationary blade row trailing edge. A relationship for the change in shed vorticity as a function of rotor bow shock strength was presented that predicts the difference between close and far spacing TURBO simulations.

Very fine three-dimensional meshes are required to capture the details of the unsteady flow field in the TURBO simulation. A detailed time-average comparison of these simulations with steady state exit profiles measured behind the SMI rotor was presented in [4]. A three-dimensional grid is required to calculate the vorticity vector and an inward radial migration of the vortices shed from the tip of the wake generator must be resolved to correctly predict the radial efficiency profile at the exit of the rotor.

The vortex model presented in [3] has been extended, applied to three dimensions, and the results compared to time-accurate CFD simulations [5]. It is based on a Burger vortex core model. The vortex is superimposed on the mean 3D flow field solved with a steady state flow solver. The vortex is advected at the mean relative flow velocity. The model predicts the qualitative and quantitative features of the vortex that is shed in time by the interaction of the rotor shock with the trailing edge of the upstream strut. These features are highly three-dimensional which is picked up by the new model.

[1] Gorrell, S. E., Okiishi, T. H., and Copenhaver, W. W., 2003. "Stator-Rotor Interactions in a Transonic Compressor, Part 1: Effect of Blade-Row Spacing on Performance". *ASME Journal of Turbomachinery*, **125**, pp. 328–335.

[2] Gorrell, S. E., Okiishi, T. H., and Copenhaver, W. W., 2003. "Stator-Rotor Interactions in a Transonic Compressor, Part 2: Description of a Loss Producing Mechanism". *ASME Journal of Turbomachinery*, **125**, pp. 336–345.

[3] Gorrell, S. E., Car, D., Puterbaugh, S. L., Estevadeordal, J., and Okiishi, T. H., 2005. "An Investigation of Wake-Shock Interactions with DPIV and Time-Accurate CFD". *ASME Paper GT2005-69107*.

[4] Turner, M. G., Gorrell, S. E., and Car, D., 2005. "Radial Migration of Shed Vortices in a Transonic Rotor Following a Wake Generator: A Comparison Between Time Accurate and Average Passage Approach". *ASME Paper GT2005-68776*.

[5] Turner, M. G., Gorrell, S. E., and Car, D., 2006, "A Model of Compressor Blade Row Interaction with Shock Induced Vortex Shedding". AIAA Paper 2006-4459.

## UNSTEADY FLOW DOWNSTREAM OF A TRANSONIC ROTOR

W. Solomon, H-W. Shin, and D. Wilkin  
General Electric Aviation  
Evendale, OH

A transonic fan model has been run in the NASA 9x15 wind tunnel. Data obtained with a crossed hot-wire technique is presented. Measurements downstream of the fan blade are compared with a steady RANS CFD code. Comparisons are shown at a design speed and at an over-speed condition. Under these conditions, the levels of turbulence predicted and measured in the rotor wake and in the tip flow are significantly higher than commonly used in simplified experimental configurations. The X-wire data suggests that CFD under-predicts the velocity and angle perturbations due to the rotor wake at the measurement plane. Estimation of the vector diagrams indicates that the CFD may be under-predicting deviation off the rotor blade. At the over-speed condition a more significant difference between the predicted and measured radial flow distribution is observed. Grid refinement and use of a transition model provides a modest improvement to the simulation, but does not explain the significant differences seen at over-speed.

# DNS OF TRANSITION IN A LINEAR COMPRESSOR CASCADE

Tamer A. Zaki  
Mechanical Engineering  
Imperial College London, England

Paul A. Durbin  
Aerospace Engineering, Iowa State University  
Ames, IA

Jan Wissink and John Rodi  
University of Karlsruhe, Germany

A Direct Numerical Simulation (DNS) of flow over a compressor blade with incoming free-stream turbulence was performed. The geometry corresponds to an experimental configuration. The surface pressure distribution is in good agreement with lab data. This gives some confidence that the configuration is realistic.

Due to the incident turbulence, with  $Tu = 2.5\%$  at the leading edge plane and the moderate Reynolds number, ( $Re = 1.4 \times 10^5$ ), transition to turbulence occurs on both sides of the airfoil. The adverse gradient on the pressure side promotes transition. The favorable gradient on the suction side delays it, but deceleration toward the rear produces a large-scale instability and rapid transition. The simulation required approximately  $84 \times 10^6$  grid points.

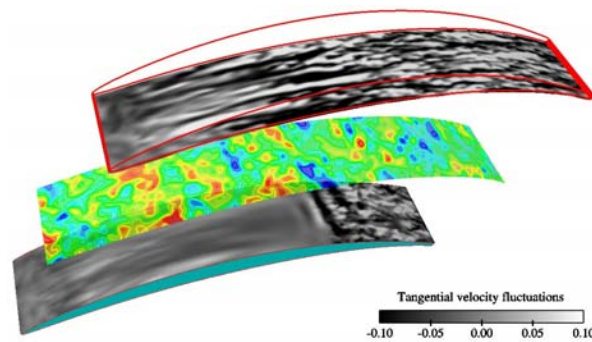

The pressure surface boundary layer undergoes by-pass transition in a manner similar to a flat-plate boundary layer subject to free-stream turbulence: the incident vortical disturbances trigger the formation of elongated boundary layer perturbation jets (or streaks) with amplitudes on the order of 10% of the mean flow. The inception of turbulent spots, which leads to breakdown, is triggered on the backward perturbation jets (negative  $u$ -fluctuations). The turbulent patches, easily identified in both the wall-normal and the spanwise fluctuations, spread and finally merge into the downstream, fully turbulent region.

The suction surface boundary layer is initially subject to a FPG, followed by a strong APG. The FPG suppresses the formation of boundary layer streaks. The result is a stabilized boundary layer that does not undergo by-pass transition and remains laminar. Farther downstream, the strong APG causes the laminar boundary layer to separate, which is followed by turbulent reattachment.

# DNS OF FLOW AND HEAT TRANSFER IN TURBINE CASCADES UNDER THE INFLUENCE OF FREE STREAM DISTURBANCES

W. Rodi and J.G. Wissink  
Institute for Hydromechanics  
University of Karlsruhe, Germany

With the much increased computer resources available today, the complex flow and heat transfer processes in low-pressure turbine cascades can be studied in detail at realistic Reynolds numbers with the method of Direct Numerical Simulation (DNS). These processes involve by-pass transition under the influence of periodically oncoming wakes, laminar separation and subsequent transition and reattachment, which can be suppressed by the periodically passing wakes, and a strong influence of the free-stream turbulence, either distributed or concentrated in wakes, on the heat transfer in laminar and pre-transitional regions of the turbine-blade boundary layers. The present contribution reports on various DNS carried out to study these processes for flows in turbine-related geometries. First, DNS-results of the flow in a T106 LPT cascade are shown for  $Re = 5.18 \times 10^4$  based on the approach flow velocity and the axial cord length, with passing wakes generated upstream by moving cylinders. In this case, in the adverse-pressure-gradient region on the suction side, the boundary layer tends to separate. The emphasis of this study [1] was to differentiate between the effect of large-scale fluctuations (i.e. velocity deficit) in the wake and small-scale turbulent fluctuations, and hence in addition to the basic simulation with the wake having both a deficit and turbulence, simulations were carried out with the small-scale disturbances removed. This study shows (see Fig.1) that transition to turbulence strongly depends on the presence of small-scale disturbances. Further, DNS of the flow and heat transfer in a MTU-cascade [2] are presented for  $Re = 7.2 \times 10^4$ , simulating an experiment of Liu and Rodi [3]. Calculations are presented for various wake-passing frequencies. The unsteady wake data entering the computation domain were provided by Wu and Durbin of Stanford University [4]. The mechanism of heat transfer affected by free-stream disturbances can be studied in detail (see Fig. 2). The influence of the wakes on the transition and the corresponding increase in heat transfer is predicted correctly, but the significant increase in heat transfer due to the passing wakes in the pre-transitional region on the suction side and in the fully laminar boundary layer on the pressure side is underpredicted. These differences are most likely due to the fact that the wake data of Wu and Durbin correspond to the far wake with relatively small-scale turbulence while in the experiments the wakes generated by moving cylinders contained larger vortical structures which are known to be more efficient for increasing laminar heat transfer. Calculation are under way, in which more realistic wake data stemming from an own DNS of cylinder flow are used as inflow data. Further, the effect of the length scale of free-stream turbulent fluctuations on laminar heat transfer is studied in a separate calculation for boundary layer flow within favourable pressure gradient. Results of these calculations are also presented (see Fig. 3).

## References

- [1] Wissink, J.G., Rodi,W., Hodson, H.P.: The influence of disturbances carried by periodically incoming wakes on the separating flow around a turbine blade, *Int. J. Heat and Fluid Flow*, 27, pp. 721-729, 2006

- [2] Wissink, J.G., Rodi, W.: DNS of flow and heat transfer in a turbine cascade with incoming wakes, to appear in *J. Fluid Mech.*
- [3] Liu, X., Rodi, W.: Velocity measurements in wakes-induced unsteady flow in a linear turbine cascade, *Exp. in Fluids* 17, pp. 45-58, & Surface pressure and heat transfer measurements in a turbine cascade with unsteady oncoming wakes, *Exp. in Fluids* 17, pp. 171-178, 1994
- [4] Wu, X., Jacobs, R.G., Hunt, J.C.R., Durbin, P.A.: Simulation of boundary layer transition induced by periodically passing wakes, *J. Fluid Mech.*, 398, pp. 109-153, 1999

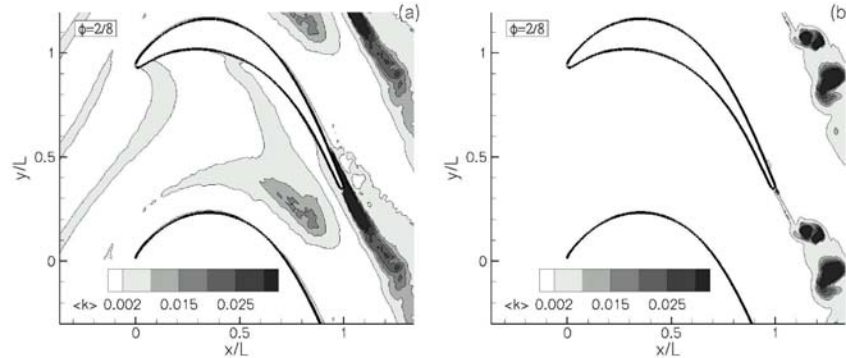

Figure 1: Flow in the T106 turbine cascade with incoming wakes. Phase-averaged turbulent kinetic energy at midspan at one instant. Left: simulation with realistic wakes, Right: simulation with turbulence removed from the wakes.

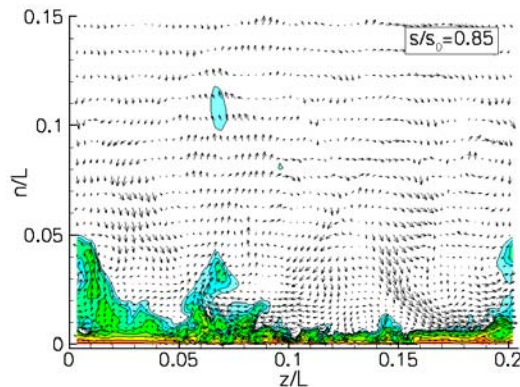

Figure 2: Simulation of flow around and heat transfer from a MTU turbine blade. Snapshot showing the fluctuating velocity field (vectors) and the instantaneous temperature field (contours) on the suction side at a cross-section near the trailing edge

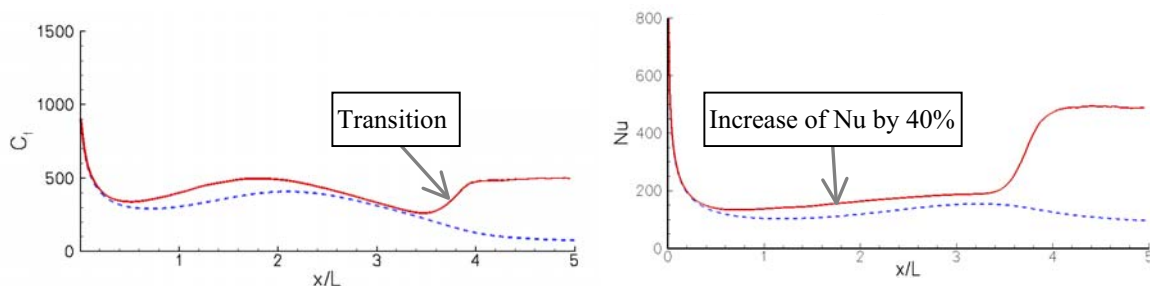

Figure 3: Accelerating flow over and heat transfer from a flat plate. Left: Skin friction coefficient, right: local Nusselt number. Solid line: simulation with incoming grid turbulence of  $Tu=5\%$  and integral length-scale  $\Lambda=0.0415L$ , dashed line: simulation without free-stream turbulence (fully laminar).

## DESIGNING TURBINE AIRFOILS TO ANSWER RESEARCH QUESTIONS IN UNSTEADY AERODYNAMICS

J.P. Clark and P.J. Koch  
Turbine Branch, Turbine Engine Division  
Propulsion Directorate, Air Force Research Laboratory  
Wright-Patterson Air Force Base, OH

Recently a complete design, analysis, and optimization system for turbine airfoils was implemented at the Air Force Research Laboratory. The system enables 2D and 3D design of turbine components using both traditional and design-optimization methods, and it allows for the advanced interrogation of unsteady flowfields. The design system is modular, and it currently leverages several government-funded analysis tools. These include the meanline analysis code and airfoil-shape algorithm due to Huber<sup>1</sup>, the 2D and 3D RANS solvers of Dorney and Davis<sup>2</sup>, and the 2D and 3D LES solvers of Davis<sup>3</sup>. Pre- and post-processing are handled through a GUI-based analysis system, and design can proceed using several optimization methods, including sequential quadratic programming, genetic algorithms, and design of experiments. The system also includes a novel means for assessing convergence in periodic-unsteady flows and for detecting time-resolved flow features of interest<sup>4</sup>. The design system was created to allow the development of non-proprietary airfoil geometries that can be used throughout industry and academia for code validation and to help answer research questions in unsteady flows. Example geometries that were designed with the system are described along with the specific issues in unsteady flows to be investigated through testing of the components. These examples pertain to both high and low pressure turbines.

A pair of high-pressure turbines (HPTs) was designed that are consistent with military engine cycles envisaged for 2017 and beyond. The first HPT is consistent with requirements of both a Long Range Strike aircraft and the High Efficiency Embedded Turbine Engine. The transonic turbine has a high degree of reaction and is therefore also consistent with a contra-rotating low pressure turbine (LPT). Thus, the test turbine will be useful to address predictive shortfalls associated with vane-blade interaction for such geometries identified in other studies<sup>5,6</sup>. The second single-stage HPT was designed for a future UAV engine cycle. The turbine is an un-cooled, ceramic, bladed disk, and aerodynamic losses are likely to be dominated by secondary and trailing-edge losses. Additionally, the large trailing-edge diameters typical of a ceramic blade could result in inherent unsteadiness and strong unsteady interactions as observed previously<sup>4</sup>.

A series of LPT geometries has also been created primarily to explore the expanded design space for high lift airfoils enabled by developments in transition modeling due to Praisner and Clark<sup>7</sup> that were first presented at Minnowbrook IV<sup>8</sup>. The L1M airfoil was the first LPT blade designed at AFRL, and it was tested in a cascade by Bons et al.<sup>9</sup>. The L1M has 17% greater lift than the P&W Pack B airfoil, and it had a significantly better Reynolds-lapse characteristic. The airfoil had a re-attaching separation down to inlet Reynolds numbers less than 20,000 based on axial chord. This level of performance was achieved

without either active or passive (e.g. wake-generated unsteadiness) flow control. Subsequently, a second LPT airfoil was designed<sup>10</sup>. This airfoil, designated L2F, has 40% greater loading than Pack B, and it is also predicted to have better low Reynolds-number performance. Testing of the L2F airfoil will take place in early FY07. Additionally, a pair of low-pressure turbine stages is being designed for testing at Notre Dame University in the transonic turbine rig described by Ra et al.<sup>11</sup>. These turbines will also explore the limits of high-lift in LPTs and they will facilitate verification of unsteady loss mechanisms identified recently by Praisner et al.<sup>12</sup>. Further, the turbines are to serve as platforms for development of flow control concepts.

These airfoil geometries and other profiles designed to explore both reduced heat load<sup>13</sup> and variable geometry turbine nozzle guide vanes are available to interested researchers and development engineers in industry and academia.

- [1] Huber, F., 2006, Personal Communication.
- [2] Dorney, D. J. and Davis, R. L., 1992, "Navier-Stokes Analysis of Turbine Blade Heat Transfer and Performance," ASME Journal of Turbomachinery, Vol. 114, pp. 795-806.
- [3] Davis, R. L., 2006, Personal Communication.
- [4] Clark, J. P. and Grover, E. A., "Assessing Convergence in Predictions of Periodic Unsteady Flowfields," ASME Paper No. GT2006-90735.
- [5] Clark, J. P., Stetson, G. M., Magge, S. S., Ni, R. H., Haldeman, C. W., Jr., and Dunn, M. G., 2000, "The Effect of Airfoil Scaling on the Predicted Unsteady Loading on the Blade of a 1 and ½ Stage Transonic Turbine and a Comparison with Experimental Results," ASME 2000-GT-0446.
- [6] Davis, R. L., Yao, J., Clark, J. P., Stetson, G., Alonso, J. J., Jameson, A., Haldeman, C. W., and Dunn, M. G., 2004, International Journal of Rotating Machinery, Vol. 10, No. 6.
- [7] Praisner, T. J., and Clark, J. P., 2004, "Predicting Transition in Turbomachinery, Part I – A Review and New Model Development," ASME Paper No. GT2004-54108.
- [8] Praisner, T. J., Clark, J. P., Grover, E. A., Bertuccioli, L., and Zhang, D., 2003, "Challenges in Predicting Component Efficiencies in Turbines with Low Reynolds Number Blading," Minnowbrook IV: 2003 Workshop on Transition and Unsteady Aspects of Turbomachinery Flows, NASA/TM-2004-212913, page 58.
- [9] Bons, J. P., Hansen, L. C., Clark, J. P., Koch, P. J., and Sondergaard, R., 2005, "Designing Low-Pressure Turbine Blades with Integrated Flow Control," ASME Paper No. GT2005-68962.
- [10] McQuilling, M. W., 2006, "Design and Validation of a High-Lift Low-Pressure Turbine Blade," PhD Thesis Proposal, Wright State University.
- [11] R. Ma, S. Morris and T. Corke, "Design of a Transonic Research Turbine Facility," AIAA Paper No. 2006-1311.
- [12] Praisner, T. J., Clark, J. P., Nash, T. C., Rice, M. J., and Grover, E. A., 2006, "Performance Impacts Due to Wake Mixing in Axial Turbomachinery," ASME Paper No. GT2006-90666.
- [13] Johnson, J. J., King, P. I., Clark, J. P., Flanagan, M. F., and LeMaire, R. P., "Optimization of a Low Heat Load Turbine Inlet Vane," AIAA Paper No. 2006-3386.

## UNSTEADY CFD SIMULATIONS FOR IPC OFF-DESIGN OPERATING CONDITIONS

K. Engel  
MTU Aero Engines GmbH  
München, Germany

Dirk Nuernberger and Edmund Kuegeler  
DLR  
Cologne, Germany

An IPC is characterized by its extremely wide aerodynamic operating range with strong requirements concerning efficiency and surge margin. While the usual way of tackling this design goal is the introduction of variable stator vanes the approach chosen by MTU is the introduction of a powerful Casing Treatment.

Thus the underlying multipoint design has to fulfill the mentioned requirements: Flow path and blade design for very high efficiency; Casing treatment design for maintaining surge margin in off-design operating conditions. This ambiguous goal leads to the demand for very sophisticated aerodynamic design tool capabilities like steady and time accurate flow prediction in fully turbulent and transitional flow regimes due to different operating conditions as well as the resolution of different geometry features outside the main flow path.

In the paper the effect of different numerical resolution of the “real” geometry as well as the “real” behavior of the flow e.g. steady simulation vice time accurate simulations is discussed. The differences are analyzed and compared to rig-measurements.



# **Plenary Sessions**

**Reports of Working Groups  
and  
Transcripts**



Breakout Group Report

## Heat Transfer & Film Cooling

**Mike Dunn**

The Ohio State University

Group Participants:

**R. Abhari**

**J. Bons**

**J. Clark**

**M. Dunn (Chair)**

**J. Fabian**

**L. Langston**

**T. Okiishi**

**M. Oldfield**

**K. Thole**

## Heat Transfer & Film Cooling - Big Picture

- Where is the step change to come from?
  - Will it be from internal cooling technique?
  - Will it be from different external cooling configurations?
  - Will it come from improved distribution of cooling gas we have?
  - Improvements in materials???
  - Conjugate heat transfer?
  - Or will it be something very different?
- After we determine where we need to place the cooling gas, how do we effectively distribute?

## Big Picture (Con't)

- Recognize that hot section technology is a sensitive & proprietary arena among the engine companies and countries (ITAR)
  - These constraints are bigger than the academic community and are clearly slowing down progress
  - Academics need to find ways to work within these constraints to work with the engine companies and government to help do so

## Heat Transfer & Film Cooling - Experimental/Analytical

- Uncooled HPT stage
  - Very few (or none) data sets for the HPT stage are generally available
  - Can calculate 2-D vane & blade pretty well
  - Endwall predictions not in as good shape from academic viewpoint
    - Proprietary codes have been compared with data and do quite well
      - Neither geometry nor codes generally available
  - Blade tip region
    - Again, industry has lots of tip data, but geometry not generally available
    - Codes that industry has used to predict these measurements are available

## Experimental/Analytical (Con't)

- Cooled HPT stage - including hot streaks and free stream turbulence
  - Again, no data sets (including geometry) are available to academic community
  - Need time-accurate code to analyze data from HPT measurements - not available for 3-D case at the moment
    - Some modeling of the cooling injection ongoing
      - Abhari macro model
      - Leylek modeling of individual holes
      - Durbin modeling of turbulence, V2F
    - Need a closure term that correctly accounts for overall unsteadiness in a turbomachinery application
    - Purge flows & influence on performance and heat transfer
    - Tip cooling physics
    - Roughness and material degradation
    - Some generally available 3-D time-accurate CFD codes could form base for detailed modeling of film-cooled HPT problem
      - Great deal of work needed to incorporate modeling to improve/develop better design tools

Breakout Group Report

# Fans & Compressors

**Bill Solomon**  
GE Aviation

Group Participants:

**K. Engel**  
**S. Gorrell**  
**J. P. Gostelow**  
**J. Katz**  
**W. Solomon (Chair)**  
**G. Walker**

## Fans & Compressor Discussion

“Is compressor design mature?”

> Industry members – “far from it”

– Opportunities

- Flow control (passive, active)
- Off-design including Surge Control
- Highly loaded machines
- Scaling & small machines
- Etc...

– Discussion of design constraints...why isn't (or is) the LPT experience transferable?

Roughness – is transition relevant in high roughness  
what is sand grain roughness anyway

## People/Management issues

Relationships between industry/government and Universities is perceived as weak

Incentives for bright students to enter the field dwindling...

Government agency funding decreasing

Industry controlling costs with university centers of excellence

- > Seen as threatening diversity in research community
- > Other funding models that don't pre-select institutions suggested as more competitive approach

Shortage of people with critical physical understanding

## Application Gap

How do we improve CFD state of art?

How do we bridge the gap between industry and research?

- > Reduction of highly detailed experimental or DNS results into practical information
- > Little work ongoing to improve RANS modeling
  - Is RANS modeling mature?
- > Some transition modeling successes
  - Many other questions

Industry isn't funding these efforts

## Problem areas...(not prioritized)

Tip-leakage flows

Curvature – streamline and blade surface

Potential for exploitation of wake-induced transition & calmed regions

Critical interpretation and validation of analysis techniques

Instrumentation costs & capability (where are the nano sensors???)

Roughness, deterioration

Corner flows

Turbulent separation

Shock BL interaction

- > On blade

- > Blade/vane

Langford, Gorrell

Appropriate level of modeling & communication between them  
(Multibladerow unsteady -> ... ... -> 1 D modeling)

Areas that can benefit from good fluid mechanics, but require larger interdisciplinary cooperation

- > Acoustics

- > Aeromechanics

- > Distortion sensitivity and transfer



Breakout Group Report

# Flow Control

**Tom Corke**

University of Notre Dame

Group Participants:

**J. Bons**

**D. Car**

**T. Corke (chair)**

**H. Fasel**

**F. Haselbach**

**H. Hodson**

**J. Hourmouziadis**

**R. Jefferies**

**E. White**

## Topics of Discussion

- Components of gas-turbine engines where flow control can have an impact.
- Prioritize these in terms of impact and feasibility.
- Fundamental fluid physics associated with engine internal flow control.
- Rank impact of fluid physics elements.

## Gas-Turbine Flow Control

Component	Impact 1-5	Feasibility 1-5	Rank
Exit Guide Vane Control (Fan)	2	5	7
Inlet Distortion Control (nacelle / embedded-S)	4	5/2	9/6
Surge Control (Active)	5	3	8
Stator Control (Virtual Variable Guide Vane)	4	3	7
Stator Control (Conventional GV Separation)	3	3	6
HP-LP Compressor & Turbine Transition Duct	3	2	5
Schedule Cooling Air	5	4	9
Main Flow Fluidic Control (thrust vectoring & variable cycling)	5	3	8
Combustor Control (Acoustic Resonance)	5	2	7
Noise Control (Fan, Jet, ...)	5	1	6
LPT Separation Control	2	3	5

## Associated Fluid Physics

Physics	Universality /11	Mature 1-5
Combustion	1	1
Flow Separation: Turbulent	7	3
Flow Separation: Laminar	7	5
Flow Separation: 3-D (eg. Corner Flows)	7	2
Boundary Layer Transition	3	3
Coherent Vortical Flows (Tip Flows, Wakes, ..)	2	2
Shock/BL Interaction	4	2
Jets in Cross-stream (leakage flows, active jets)	6	3
Turbulent Mixing	3	4
Wall Roughness	2	3

## Road Map

- Exploit flow sensitivities – Maximize receptivity to control.
  - Formalism for complex geometries >> direct bi-global analysis (viz. Vassilis)
- Define canonical flow problems aimed at most universal flow (6+) physics to advance flow control.
  - e.g. Turb. Sep. Control effect of curvature, roughness, actuator design

## Road Map

- Early applications of flow control on **non-mission-critical** components.
  - Build database of experience.
- Ultimate benefit of flow control comes when confident enough to design assuming flow control from the beginning.
  - e.g. lower drag wings comes by using section shapes that are on the verge of separation. Combined with FC, these can be practical.

Breakout Group Report

## Computational Methods & Transition

**Paul Durbin**

Iowa State University

Group Participants:

**P. Durbin (Chair)**

**T. Fransson**

**B. Holley**

**R. Narasimha**

**T. Praisner**

**W. Rodi**

**J. Seume**

**V. Theofilis**

**M. Yaras**

### Practical prediction methods

- State of art: integral models  $R_0$  + Buckingham  $\Pi$ .  
Boundary layer framework. OK for turbomachinery (?)
- Future: field variables; transport equations. General purpose codes (e.g., Menter et al). Local parameters:  $\omega d^2 / \nu$
- In all cases, data correlation gives transition criterion. Special purpose formulas --- wake or f.s.t; separated or attached --- are needed
- LES with near DNS resolution prior to transition
- Basic research  $\rightarrow$  understanding, better models and correlations

## Critical review of models

- I.e., verification and validation
- Industry uses public and proprietary benchmarks. Data correlations sometimes are proprietary too. But are guided by open literature
- Experiments should be reproducible, e.g. repeated at two or more institutions. Well set inflow and boundary conditions
- What experiments? Transition on convex and concave surfaces; 3-D skewed boundary layers (not cross-flow).
- DNS for detailed, well characterized data, for testing concepts and for exploration

## Comments

Beyond LPT: 2<sup>nd</sup> stage HPT, hub endwall, small engines, high altitude, compressors, separation control, roughness

Modelers, computationalists and experimentalists must work in concert.

Experiment, computation and brain-power: experimenters should have access to DNS data to pursue their ideas; data mining should occupy more of our time

# **Minnowbrook V: Unsteady Flows in Turbomachinery**

## **Industry Panel – Final Report**

Simon Gallimore – Rolls-Royce

Jochen Gier – MTU

(Greg Heitland – Honeywell)

Louis Povinelli – NASA Glenn

Om Sharma – Pratt and Whitney

Allan van de Wall – GE Aviation

## **Contents**

- General comments
- Positive progress since Minnowbrook IV
- Industry panel outcome
- Prioritized turbine projects
- Prioritized compressor projects
- Miscellaneous

## General

- Industry appreciates participating in Minnowbrook V
- Aero and heat transfer communities should work more closely together
- We need to leverage the excellent 3D model work to develop physics based 1D models (Greg Heitland)

## Positive Progress

- Reza keynote (unsteadiness and modeling)
- DNS:
  - Heat transfer
  - LPT
  - Compressor
- Unsteady transonic interaction work
  - Model to account for unsteadiness for the designer
  - New Blade Row Interaction (BRI) rig
- Roughness experiment
- Flow control

## Industry Panel Outcome

- Prioritized list of projects for turbines and compressors
- Selected projects that match the skills of researchers in this room to specific industry problems

## Turbine (1)

- **#1: LPT Closure**
  - Can participants help in documenting progress on LPT work? Articles in process.
  - But work here is not complete (e.g. roughness), we need to move onto other areas of interest to industry.
  - Proposal: Prepare a reference report on the LPT work (NASA/AFOSR).



## Turbine (2)

- **#2: Heat Loads in Turbines**
  - Heat transfer analysis considering both internal passages and external flow simultaneously
  - Proposal:
    - Identify test data where complete aero/heat transfer data is available.
      - LSRR (UTRC)
      - Mike Dunn's Garrett (OSU) rig
      - MIT/RR rig
      - GE rig (TBD)
      - VKI transonic stage
      - QinetiQ rig, other.....)
    - Use new rigs with analysis to obtain aero/heat transfer data
      - NASA Rig: W6 HPT single stage UEET turbine (2008)
      - Proposed AFRL turbines (John Clark)

## Compressor (1)

- **#1: How do we design for forced unsteadiness which affects efficiency and operability.**
  - Forced Unsteadiness originating from:
    - Wakes / streamwise vortices from upstream
    - Potential Field (smaller influence) and shocks from embedded supersonic rotors (larger influence) from downstream
  - Blades have time varying loading distribution with forced unsteadiness
    - Can we bend the metal to take advantage of this?
    - Consider both transitional and turbulent flows
  - Proposal:
    - Greg Walker's controlled diffusion stator and do DNS on it.
    - Redesign with increased loading taking advantage of the unsteadiness

## Compressor (2)

- **#2: Roughness affects efficiency**
  - Water washing a compressor and polishing blades improves performance.
  - Can blades be designed to be insensitive to roughness?
  - Proposal:
    - Use Ed White's experiment and determine what about roughness matters to performance...
    - Review Bammert and Milsch (ASME 72-GT-48) data

## Miscellaneous

- **Next Minnowbrook, we need someone from large scale stationary gas turbines**
- **General question for CFD community:**
  - What type of analysis is appropriate to capture the generation, transport, and dissipation of the trailing edge shed vortex shown in Gorrell's presentation? Do we need DNS, LES, or is RANS with a fine grid adequate?
- **Thank you for letting us participate in the meeting.**

APPENDIX TO INDUSTRY PANEL  
IMPACT OF SURFACE ROUGHNESS  
IN AXIAL FLOW GAS TURBINE  
ENGINES

Om Sharma  
Pratt & Whitney

IMPACT OF SURFACE ROUGHNESS ON HEAT TRANSFER  
COEFFICIENT FOR A TURBINE ROTOR AIRFOIL (Blair -1994)

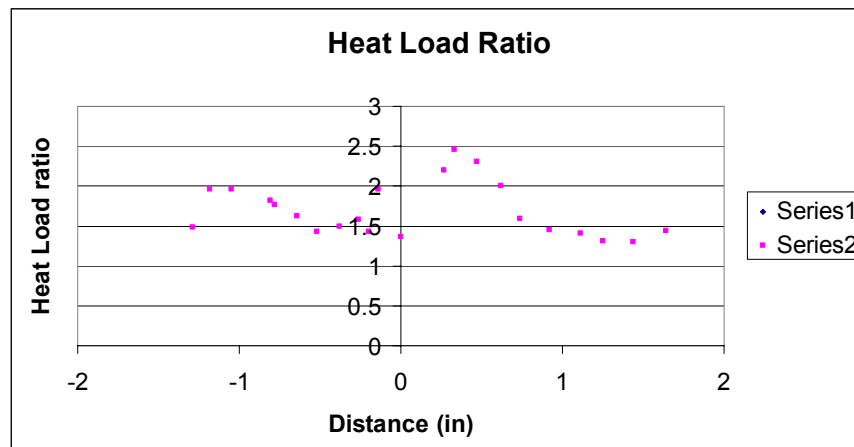

**IMPACT OF SURFACE ROUGHNESS ON PROFILE LOSSES FOR TURBINE (Speidel -1954) & COMPRESSOR (Bammert & Milsch 1972) CASCADES**

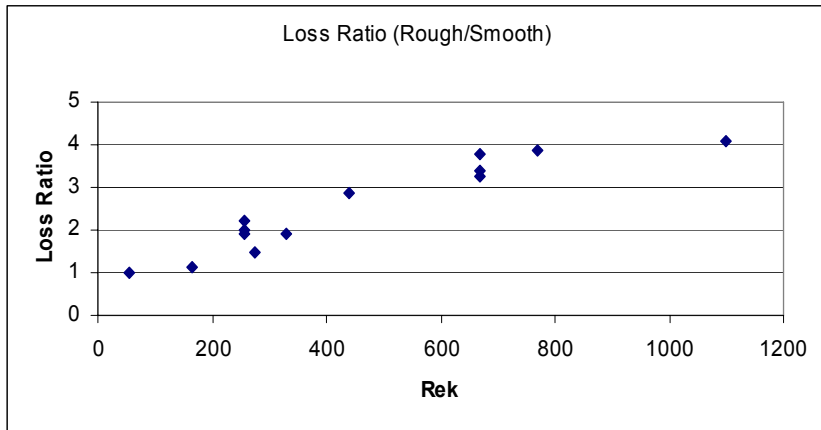

**SURFACE ROUGHNESS EFFECT ON COMPRESSOR AIRFOIL PERFORMANCE (Bammert & Milsch -1972, ASME 72-GT-48)**

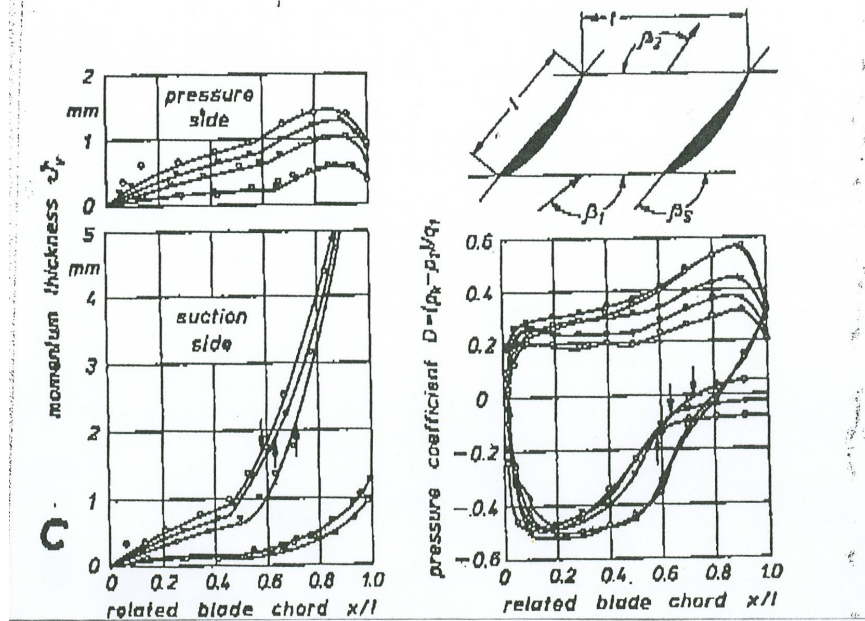

## ROUGHNESS INDUCES SEPARATION AT HIGH RE #

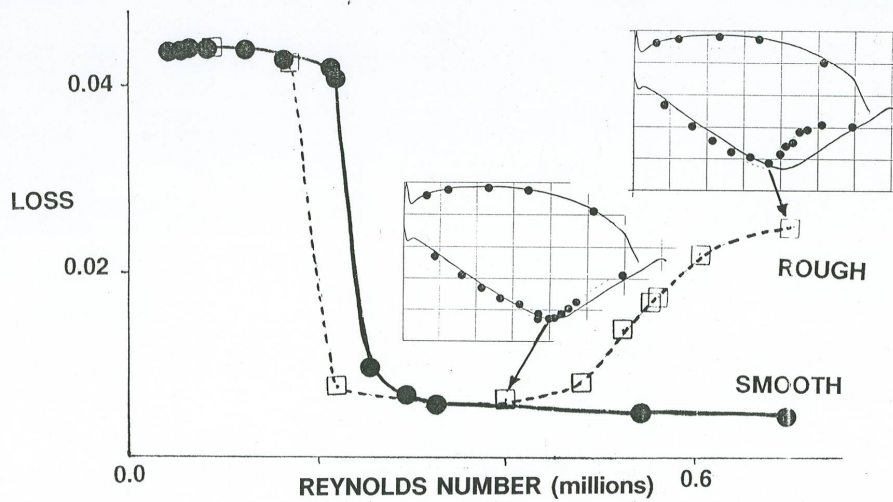

- ROUGHNESS INDUCES SEPARATION (!!!)
- WORK INITIATED TO QUATIFY IMPACT OF THIS PHENOMENON

## ROUGHNESS REDUCES LOSSES AT LOW REYNOLDS NUMBERS

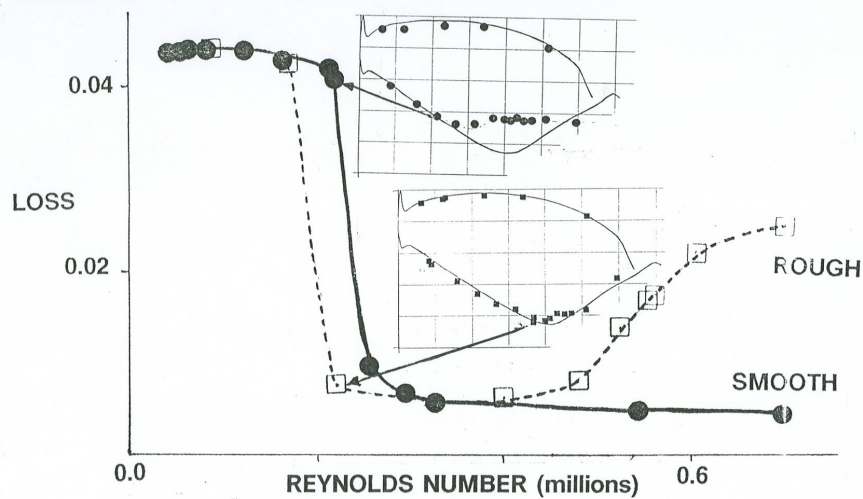

- LOSS REDUCTION DUE TO SMALLER LAMINAR BUBBLES

## SUMMARY

- Surface roughness has significant impact on the performance for both turbines and compressors
- Surface roughness can cause separation of turbulent boundary layers in the adverse pressure gradient regions for airfoils, limiting their ability to produce lift, impacting both work and stability
- For airfoils with laminar boundary layers, surface roughness can induce forced transition and yield performance benefits by eliminating laminar separation bubbles.
- Heat loads on turbine airfoils is higher in the presence of surface roughness.
- Multiplication factors anywhere between 1 & 7 are used to translate sand grain roughness to area averaged roughness measured on airfoil surfaces to book-keep performance in engines!
- Limited available experimental data on turbomachinery airfoils indicates that the adverse impact of surface roughness can be managed by designing the airfoils with “prescribed” local pressure gradients. Rigorous methodology needs to be developed to exploit this concept for design applications

## FINAL PLENARY SESSION TRANSCRIPT

Paul Gostelow  
University of Leicester  
Leicester, U.K.

### Reports and Discussions of Breakout Sessions

Oldfield: In the next session Ted Okiishi is going to be moderating the reports of the ad hoc working groups.

Okiishi: We had four working groups. These break-out groups worked very hard. I went from one to the other and I know we are in for a treat. Get your thinking caps on and take some good notes. We have some exciting conclusions coming from these groups. Mike you are the lead-off with the cooling group. Then “Unsteady Flows in Compressors and Fans” with Bill Solomon, then “Flow Control” reported by Tom Corke. Anchoring the session will be Paul Durbin with “Computational Methods and Transition.”

### Heat Transfer and Film Cooling

Dunn: I have ten minutes so we need to fly. The members of the group that participated in putting this together are listed. (*Powerpoint slides appended*). Where we want to start with our summaries is “where is the next big change in heat transfer and film cooling coming from”? Of course there are lots of options. We don’t know the answer, that’s why there are lots of question marks. Will it be from internal cooling techniques? Will it be from different external cooling configurations? Will it come from improved distribution of cooling gas that we are already providing? And of course that assumes that we know why it is not distributed correctly in the first place. We have to work that problem. Will it be from improvements in materials? And I have three question marks behind that because Om cited how many degrees we have gained in the last thirty years and it has not been out of sight. Conjugate heat transfer - another thing that we are pushing right now. Or will it be something very-very different? In terms of, “What about the cooling?”, after we determine where we really need to place it most efficiently, the real question is “How do we effectively distribute it”? Either passively or actively. It is not a trivial question. This gets you into macro or nano technology - is there some way you can actively distribute cooling to the places where you really need it, when you really need it, and then get it back at another time?

Finally there is the recognition that hot section technology is a sensitive proprietary area, among the engine companies and among the countries. In the countries we get into ITAR. In engine companies we get into competitiveness. These constraints are bigger than the academic community and it sure is bigger than this group. We are not going to make that go away. However it is, as the group concluded, slowing down progress. So we have got to find a way to work with it. I think that what we need to do as a group, with the help of the industry guys (and they are going to give you some thoughts before they get off the stage today) of ways where we can try to work these constraints with the engine companies and with the government. So there is some help coming later on that issue.

Let me move on to heat transfer and film cooling, both experimental and the analytical part. We are going to break it into two segments. The uncooled first, and we are going to talk HPT - we are always going to talk HP turbines. And we are going to talk about the whole stage stuff. We are not going to worry about flat plates or cascades now. Let’s look at the full problem. So in terms of the uncooled, there are very few data sets or none that are out there for HPTs that are generally available to everybody. We have both got

them. We have got them on this side and all the companies have got them. You have got them on the European side but they are not generally made available to all of the academic community. That was the question that came up in our break-out. That having been said, we can calculate the 2D vane and blade heat flux and aerodynamics pretty well; there have been very many demonstrations of that. The end wall predictions, from an academic viewpoint, are not in as good a shape. They are from a company viewpoint because the companies have got proprietary codes they use to do it; they are well calibrated and they've got the data. So they put it all together and do a very good job. Again we are talking un-cooled. Neither the geometry nor the codes to do that are generally available to the whole community. For the blade tip region, again industry has got a lot of blade tip data. They have got the codes to work with it, but the geometry is not generally available. If we come to the codes that industry is using to do all these predictions, those are generally available, both on this side of the ocean and on the other. On this side there is of course the unsteady code MSU TURBO which you all have access to, and there is FINE/Turbo, which is Charles Hirsch's code. They both do a great job. They both predict aerodynamics. MSU TURBO does not do heat transfer, FINE/Turbo does. It doesn't do it well, I can tell you that, but it does do it. But the codes are out there so you can usually find something to work with.

Now let's switch to the cooled; the cooled HPT. And when we talk about cooled, again we are talking the full stage data; we are talking fully cooled, we are talking hot streaks and free stream turbulence all thrown in to the picture.

No data sets are available to the academic community, including geometry. There are data sets but the academic community doesn't have them. The need for time accurate code to analyze the film cooling on the blade we all recognize; you've got to have it. It's not generally available, including heat transfer. The code is there, you can get the code, you've got to do the modeling.

Some modeling effort has already started with coolant injection. Abhari talked about it on Sunday night with his macro-model. And he's making great progress and he's well along. Jim Leylek does a lot of modeling of individual cooling holes but when you've got 600 or 800 cooling holes to worry about we start talking the kind of computer resources that Wolfgang was talking about. So we get into the big thing. Paul Durbin is doing this modeling of turbulence with V2F, as he talked about, and continuing to do. And those are all the things we need to put all of this together.

What we really need is a closure on the term, whatever it is, that correctly accounts for the overall unsteadiness in the turbomachinery application. It may not be turbulence, you can call it that, it is something. But we can sort that out. Because as we do these measurements with and without free stream turbulence that is characterized we can sort out what is turbulence and what isn't. But whatever this closure term is, we've got to work.

Purge flows and the influence of purge flows on performance and heat transfer is an important problem. It's one you can get at. It's one that Reza talked about when he gave his talk on Sunday night. People are working the problem. Again it is within the confines of the engine companies, not generally available.

Tip cooling physics is a problem. When we are running these cooled machines what is happening in the tip region with the cooling? Again some data, not generally available, and a big problem to us.

Surface roughness and material degradation, a problem again that we need to attack.

There are generally available 3D codes that you can use to perform the details of the modeling and of the film cooled problem. They are out there. The big problem we have now is a lot of modeling to incorporate these various components into a CFD code.



Basically the last point I want to make is that we don't want to develop any more codes. We've got the codes. It's the modeling of the physics that has to go into the code. Let's don't spend or waste our time developing codes.

Okiishi: Thank you Mike. I think we can take one or two questions.

Jeffries: If you go back to the big picture slide. You said we need to address this to enhance progress from a higher level than all of us. What's the next step? How are we going to get there?

Dunn: I have spoken with the industry panel and we discussed this issue at some length. In their break-out session they are going to tell us how they think we should approach this. We addressed it, we didn't want to let it hang.

### **Unsteady Flows in Compressors and Fans**

Solomon: Here's the team - a mix of industry and researchers. We started by asking ourselves "Is compressor design mature"? The industry members of the panel thought "Far from it." There is a wide range of opportunities, from flow control, surge control, advancing loading; understanding scaling and small machines better, etc. We started discussing design constraints. Asked ourselves why haven't (or have) the advances that have been made in understanding wake-induced transition in the LPT world been transferred to the compressor world. Roughness is an important issue we talked about. Is transition relevant in high roughness environments? How do you make use of the correlations that are out there using sand grain roughness etc.?

Some of the more controversial issues that were discussed were the people and management issues. There was a feeling amongst the group that the links between industry, government and researchers have grown a little weak in some of these areas. There is a feeling that the incentives for bright students to enter the field are dwindling. Government agency funding seems to be decreasing. Industry seems to be controlling costs with university centers of excellence, which were seen as threatening diversity amongst the research community. One of the suggestions was that other funding models that don't pre-select the institution but open things up more competitively amongst researchers would be appreciated. And what is missing is a shortage of people with a critical understanding that are finding their way into the industry on the research side. It is the physics we want people to be able to drill down to and understand.

As far as taking good research work and applying it to industry, we talked about the gap there from 'How do we improve our design tools?' which usually means our CFD. How do we get some of the excellent work that has been done in understanding the highly detailed physics, with some of the experimental work and DNS work that has been shown at this meeting? How do we take that and use it to improve RANS modeling? Is RANS modeling mature? What can we do to really advance that state of the art? It is generally felt that there have been some successes in applying transition models into some of the RANS codes, but there are lots of other areas where the physics needs to be augmented in these codes to help us to advance the analysis side of the equation. By and large it is felt that industry is not really funding these efforts and there is not a lot of incentive on the research side to drive down to develop that sort of tool.

Specific areas where more research can be done basically covers every type of important physical mechanism we could think of in the compressor, or in the fan. These are not really prioritized, but people have done a lot of work on tip leakage flows but a lot of work could still be done. Curvature, both in the flow field and curvature on the blade surface, and how that affects things. There has been some good work shown on this here but more could be done. How we can exploit wake-induced transition and calmed regions, on the compressive component side of things, does not seem to have been fully

addressed. Driving to a critical interpretation and understanding of ‘where the analysis techniques we typically use in industry have shortfalls’ is important to us. Instrumentation costs and capabilities: Nanotechnology had promised to advance the state of the art but it really isn’t being felt in the types of instrumentation that is readily available. So where are these wonderful sensors we should be having? Roughness deterioration, corner flows, turbulent separation, shock-boundary layer interaction, both on the blade and between adjacent blade rows, these are all areas where we have a lot of questions and could stand more input. The problem for industry is that we can’t do everything with DNS, we can’t even do everything with unsteady RANS. We have got to have a clear cascade of taking information from some of these more high fidelity modeling techniques and boiling it down, and communicating between the different levels of fidelity through the design system.

Then we talked about some of the areas that can benefit from enhancing the fluid mechanics, but really require larger interdisciplinary cooperation, which include acoustics, aeromechanics, distortion transfer and sensitivity through the machines - so there’s lots to work on. I thank you.

Okishi: What questions do you have?

Durbin: More of a comment than a question. Something that is very critical to us in universities is the need to attract good students. One of my viewgraphs says the need to attract brainpower. But one thing we find sometimes is a discouraging response from industry or other sources saying “We already know how to do that, we are already designing this, how are you helping us”? Now brainpower and students go off on tangents and they like to think about things in a more abstract way. Maybe this is just philosophical but we need industry to say “Yes, that is good. It is not immediately relevant to us but we think that is a good thing to do.” Students need to be encouraged that there are things to do.

Solomon: I think Paul makes a good point. But the best way we can improve that situation is to have more regular contact, more communication between industry and researchers. It depends who you talk to in industry. I can’t talk for other companies but there seems to have been a bit of a firewall developed between outside researchers and the designers doing the work internally. Somehow we have to break that down and encourage communication more widely.

Sharma: A comment on Paul’s comment. I think industry doesn’t really clearly state the limitations of the design process. We are always saying how good we are. If we were that good we wouldn’t be here talking about these things. I think there are a lot of issues. We need to clearly state those. I think that’s what Paul is saying. We are not encouraging students. Telling them, “Hey, these areas—we don’t do that well.” We need to do that and, like Bill is saying, more communication, the more discussion we have between industry and universities; that will help.

Okishi: O.K. Unfortunately we have to cut it off there. Thanks again Bill. We’ll turn the floor over to Tom Corke now.

## **Flow Control**

Corke: Good morning everybody. This was the flow control working group. We had a nice representation from academia, government labs. and also one token person from industry. But it was very good discussion. I had some trepidation going in because I was concerned that we wouldn’t have such a good discussion. In fact we went well past our allotted times. We had, I think, a very good camaraderie and some very open discussions. So these were design topics that we had. We formulated these in the following way: first of all we wanted to identify components of gas turbine engines where flow control can have an impact. I like to use the term “Low-hanging fruit.” So to try to define these. Then we tried to

prioritize these in terms of impact and feasibility. So from the point of view of funding or of a management plan for incorporating flow control, 'Which is the highest possibility of being incorporated or transitioning into an engine?' Then underlying fundamental fluid physics associated with these aspects of flow control. Then finally we tried to rank the impact of the fluid physics elements.

So we came up with this table. The left column has various components. These were not listed in this column in any order of priority. Then we looked at an impact. The idea of the impact was, if you could apply this flow control successfully, what would be the favorable impact on the engine performance, 1 being the lowest, 5 the highest. Then we looked at the feasibility of doing this. Some of these aspects of flow control are more difficult and so, even though it might have a high impact it may be at a very low technology readiness level and so there would be a longer lead time until it actually could happen.

And then we came up with this rank, which is simply the sum of these two columns. Arbitrarily we identified the top four here with ranks of 8 and above. This is not 5 halves; this is  $5/2$  with the / referring to either a nacelle or an embedded S-type distortion control application. So, for example, the 5 for a nacelle we thought was much more feasible, as opposed to an embedded type distortion control which we gave a 2. So the ranking here would be  $9/6$ . So the 9 here refers to the nacelle type inlet distortion. We won't go through this list, you can take a look at it. Just to note the highest. The highest component flow control applications, this panel believed, would be inlet distortion control in the nacelle. Active surge control, scheduled cooling and then also main flow fluid control, which would be thrust vectoring or variable cycling. I'm sure if I can get off this slide as quickly as possible I will limit the number of comments later.

Then, in terms of the associated fluid physics: we said let's think about the fluid physics involved in these aspects of flow control. And so we listed these. For example flow separation: turbulent flow separation, laminar, 3D, corner flows, etc. etc. Then we went back to that previous table in which there were eleven identified flow control areas. Then we said 'How many of those eleven flow control areas involve one of these?' So that became this column; you see, for example, turbulent flow separations appeared in seven of the flow control applications. Combustion was one of the areas, but only appeared once. And so what this does is that it helps you to identify the fundamental flow physics involved in the flow control which then might then help you to identify where research might need to focus.

We also tried to assign a maturity level, there was a lot of discussion about this; this is very weak. We discussed this in terms of what it really means. We left it in but I am not strong on that aspect.

Finally some 'road map' comments. One of the things is if we are to exploit flow sensitivities we need to maximize receptivity control; always there is going to be an energy budget to this. Active flow control requires some input power. You always want to minimize that so you want to make the flow do what it actually wants to do if given the right push, and so you want to maximize the receptivity control. A nice formalism for complex geometries was presented by Vassilis yesterday. So that is a formal approach to identifying the flow sensitivities. We thought that you could use that previous table to divine some canonical flow problems. In that the most universal flows were say 6 plus physics; that is those which tallied more than 6 of the flow control areas on the first table. And so for example you might have a turbulent separation control where you would look at curvature, roughness, actuator design etc. as a canonical experiment that would affect at least a majority of the flow control applications that we identified. One of the other discussions - a very interesting discussion we had - we all decided that early application of flow control would be a non-mission critical component. The reason for that is to build a data base of experience. Acceptance. One of the questions was "Has flow control actually been applied to an engine?" The answer was "Yes—in the case of the LPT which was using the unsteady wakes to force turbulent flow and maintain attached flow in the LPT blades." So it has been done and has been shown to

work. It is not something that we feel we have to break ground on. The ground has been broken, we just need to expand on that.

This is now my personal comments. This is the benefit of being the chair and making up the slides. I believe the ultimate benefit of flow control is going to come when there is enough confidence to design assuming flow control from the beginning. I will give you an example of an external flow; lower drag wings come by using section shapes that are on the verge of separation. We don't fly with those. But combined with flow control these can be practical. So that would be an example of when you design from the beginning using flow control. And that is it.

Fasel: I assume that these slides are going to be distributed? I have a recommendation, Tom, that on the enabling physics, on the second column I would put a disclaimer asterisk on that saying that there was considerable disagreement on that column.

Corke: Will do.

Clark: I have a question for Howard and Frank, are you saying that Rolls-Royce has selected airfoil counts and specific loadings to take advantage of the unsteadiness that Howard defined?

Haselbach: Yes.

Clark: Can you say what machines, or what stages on a machine?

Haselbach: An example flying is the BR715.

Okishi: Thanks. Next up we have Paul Durbin - our anchor person.

## **Computational Methods and Transition**

Durbin: I was going to make this anonymous to protect the innocent. But Ted said to list the participants at the beginning, so there they are. I'll go to the next one quickly but those are the people to blame. So we had a long discussion, well beyond our time frame I think. There were a few people like Hermann who drifted into our group on the second day. We started out with the agenda being to discuss where were practical prediction methods going. The state of the art, which was hotly defended, was integral methods based on  $R_0$ , or Buckingham  $\Pi$  as referring to the large number of non-dimensional parameters that go into data correlations. This is sort of a boundary layer framework. The question was, and of course this is the one of the things that I said about discouraging people, there is a perception that, and John Clark showed some very nice designs that can be done with this, but is this all you need for turbomachinery - these integral methods? But there is a feeling that just as turbulence prediction went from integral methods to full field,  $k - \epsilon$  or whatever, that's the direction in transition prediction as well, going from integral methods to full field transport equations that can be used in general purpose codes such as unstructured CFD codes. An example that is being discussed a lot is Menter's old model which is now available in CFX and the use of local parameters instead of integral parameters. In all cases, whether it is integral or local, the transition is coming from data correlations and special purpose formulas, such as wake-induced transition versus free stream transition, separated versus attached etc., or whatever, are needed for these types of methods.

There was a general consensus, as there was three years ago, that LES is not up to transition prediction because with Large Eddy Simulation when you don't have large and small scale eddies, there isn't a rationale there and sub-grid models can be dissipative and prevent transition. So LES is thought not to be

viable for transition. Before transition you have to have near-DNS, something approximately DNS to calculate transition, and then LES could kick in after it becomes turbulent. So there is a feeling that if you are going to go to full-blown eddy simulation that LES does not seem promising for transition.

Basic research is needed for understanding for better models and to get the correlations that we need in practical prediction. But this is not a critical review of models as the topic critical review or verification and validation would emphasize. Industry sometimes uses either public or proprietary benchmarks; we don't have these so we can't really assess how the models are doing on proprietary cases. The data correlations—unfortunately Menter's data correlation is proprietary so we can't really assess his model because we don't have all the information we need. But nevertheless it was commented that even these proprietary models are guided by the open literature, which is where most of us are working. Experiments are needed. They should be reproducible. There was some discussion of who's going to fund the same experiment at two or more institutions, but that is the goal, to have experimental data that is reproducible and has been repeated with well-set conditions. What experiments? We spent a lot of time having philosophized that we need these and they should be reproducible—what are they? During the meeting transition on concave and convex surfaces came up. There was some discussion of end wall cases where you might have transition in skewed boundary layers, and I am not referring to cross-flow instabilities but skewed boundary layers that have some form of by-pass transition.

DNS is, of course as we have seen, the place to get a lot of data. Both generating data and testing concepts and exploring ideas.

So these are a few comments. I'll just finish with some comments that came up during the discussion. Of course one of the charters here is to say what is going to go on after the LPT. There was comment made that transition is not of interest in the HPT but then there was a comment made that the second stage might not be as heavily cooled and there may be some role for transition in the HPT still. Hub end wall; I hadn't realized this but there are some experiments showing that between the horseshoe vortex and the blade there may be laminar regions with transition; that could be why some of the heat transfer predictions aren't so good. Small engines, high altitude, compressors, have been discussed already. Separation control if it is laminar separation with transition. Roughness effects. That's the end of that comment. Modelers, computationalists and experimentalists should not be working in their own corners. We all have to talk and not just throw data and ideas and models across the fence. There have to be more direct interactions. And here's that same comment. We have a lot of experiments, computations producing masses of data. We need to have more brain power applied. Somebody has to fund brain power and not just data generation. And, in that vein, experimentalists who want to try out ideas should have access to DNS data so that they can try them out and then test them in their rigs, to pursue those data; and we should be spending more time mining the data and not just generating it. That was the last comment that I have recorded.

Okishi: Questions? Terrific. I think these presenters deserve another hand. They've done a good job.

## **Report of Industry Panel**

van de Wall: Here's our cast of characters. We worked on this for quite a while. I think we finished about three o'clock in the morning (*laughter*). I'm going to go through some general comments, show some positive progress that we have seen since Minnowbrook IV. Industry panel outcome. Then one of the big things that we were supposed to do is give prioritized lists. So we got one for turbines and we got one for compressors and then some miscellaneous comments. We appreciate being asked to participate here. We thought it was a good meeting. I learned a lot. I'm not a heat transfer guy or a transition model

guy, I'm a compressor guy so I learned quite a bit. One of the comments that was made, and we endorse this, is that the aero and the heat transfer committees should work more closely together and we got some comments about that. And Greg, who couldn't be with us, and we all agree with this, is that we need to leverage more the excellent 3D CFD models that we saw, especially the DNS results, bringing these together into a 1D physics-based model that we can use.

Positive progress. Reza's keynote embracing the unsteadiness theme. And at the end he was saying that modeling is a good thing to do. Instead of everyone running 3D unsteady DNS and everything, we need to model it. The DNS, I was particularly impressed by that. The heat transfer DNS, the ones on the LPT; and the compressor which I am really interested in was very impressive. The unsteady transonic interaction work of Steve Gorrell at AFRL. We really liked the model that you are trying to put together to account for unsteadiness. It is something that we can use in design. So keep working on that, that's a good thing. And then of course, the blade row interaction experiment is excellent. Looking at the shocks and how they impact a loaded stator upstream. As we move to higher and higher loadings and embedded supersonic stages we need to really work this problem to see the impact this shock is having on the upstream stator. And then we really liked the roughness experiment Ed White did at Case. We would like to see more of that and I'll talk about that a little too. And then flow control.

We got to prioritize and list the projects, and we didn't try to select everything where we think unsteadiness is affecting us. One of the things is part-speed operability and what Carl was saying about his topic – that's a big problem. We wanted to pick something that the researchers in this room could have a big impact on.

So for the turbine.

Number 1. LPT closure. There's a lot of good work done here and maybe the participants who worked on this and helped in documenting the progress on this maybe will put a NASA TM together or something and produce something that we can all get our hands on and review. This is just good documentation. We want to emphasize though that the work here is not complete. There are still areas to work on—like roughness. A lot of roughness work has been reported. It's not that we are saying the work is done but we would like to get a good closure on that. That's a number one issue.

Number 2 is heat loads of turbines. We feel that you should consider that, both internally and externally simultaneously. So we have a proposal for that too. First thing is to identify some test data where the aero and heat transfer data exist so that the two communities can come together. We've got a laundry list of some possible cases. We are not trying to implicate anybody to do any work but these are some possible cases:- the UTRC rig; Mike Dunn has a rig, maybe we can get some data from that; MIT; Rolls-Royce rig; the GE rig; the VKI transonic stage; the QinetiQ rig, and maybe some others if people know about them. And then, of course, we can always use new rigs, if they exist. John Favian told me about one of them. They are trying to run a new HPT single stage UET turbine in W6 at NASA Glenn; maybe that's a possible candidate. We'd like to propose the AFRL turbines that Tom Corke talked about. So maybe we could do something there, and Tom, I think you said that maybe there would be more of a wide distribution on that so maybe we should work on that.

That was two for the turbines and I have two for the compressors.

Number 1 is how do we design a compressor, a blade, a fan or a rotor to account for a forced unsteadiness? The forced unsteadiness we are talking about is the wakes coming from the upstream blade rows, or a downstream potential field, which is weaker but again the shock waves that come from an embedded highly loaded supersonic stage, which we are starting to see more of. What happens is that the stator or rotor has these time varying loading distributions that you are not used to looking at when you

are designing a blade. So you get all kinds of valleys and humps and the envelopes of unsteadiness. How can we take advantage of that? We need to look at that in more detail. So our proposal here is that Greg Walker's controlled diffusion stator designed by Rolls-Royce—take a slice of that and do DNS on that. Then put wakes in upstream and re-design the stator using the DNS and eventually build it. So that would show a good comparison between a stator that wasn't designed for unsteadiness and one that is. And with the DNS we'll have the best model that we could possibly get.

The other one was roughness. We've all discussed—all the engine companies—that when the performance of a compressor drops off we wash it and it gets better. Or if we build the compressor and its a little low in efficiency we go “give us better blades—just polish them all”—and it gets better. So what is really causing that? Can we design blades to be more sensitive to that? And keep the high level that we started with – not the low end. Our proposal here would be Ed White's experiment. We were impressed by how he characterized this. What is sand grain roughness anyway? Someone else made a comment about that too. Determine what about roughness matters to us. There is some data that Om showed us in an ASME paper in 1972—we would like to go back and review that and then see what can be done, somewhat like Ed White's experiment.

Some miscellaneous items. At the next Minnowbrook we think we probably need someone from the large stationary gas turbine industry. I had a general question for the CFD community. Steve Gorrell showed this vortex that comes shedding off the wake generator that he had in this SMI rig. We did some work with an experiment; we put a shock into a stator blade from the back—simulating a downstream rotor. You get this shed vortex. We matched it with an unsteady CFD code. What type of model is appropriate to capture that? What would you run to capture that properly? We would just run an unsteady RANS, because that's all we have - that's all we can really do. But what is actually required to capture that? Do we have to go to DNS? Can we do an LES, can we do an unsteady RANS with a fine enough grid and time step that we can capture that kind of physics?

I think that's it. Thanks for letting us participate in this meeting. It was a great learning experience for me and I think we all benefited.

Oldfield: Thank you very much Allan but don't go away just yet – we have about fifteen minutes for questions. We'll start off with Paul Gostelow.

Gostelow: That last question, on what is needed to capture that vortex shedding. It is not too difficult to answer. We've done plenty of this and I'm sure other groups have too. You can capture the topology of what's going on with a fine enough grid Euler code. Even an Euler code will give you that first level of topology, the vortex shedding and stuff like that. As you go to RANS you pick up more of the fine detail of the turbulence. What the Euler code doesn't give you is good losses and the detail that you really need. So you really need to go to RANS to get the losses right. And then you begin to do that and then it becomes a matter of grid resolution. Obviously if you had DNS available for it that would be fantastic but you probably don't need to go that far in doing a decent job on capturing that vortex shedding situation. That's my experience anyway, other people may have different experience.

van de Wall: What about as this vortex goes downstream, you have your interface plane, which is a sliding mesh in an unsteady calculation you go down into the rotor. Now you put this vortex, this viscous flow, into a part of the grid that is basically made for Euler flows, it is pretty coarse. So now what do you do downstream? You had something that had maybe thirty points across a boundary layer. You put it into mid passage region and you have two points that you are picking up. How much do we have to resolve this to?

Gostelow: That is obviously taking it a step further.

Rodi: Well a lot of testing has been done on the flow around a circular cylinder. There it has been found that RANS modeling didn't do too well. Maybe Paul has different experience but we found that because you really have a three dimensional structure with these shed vortices that it is LES that is doing the job there. I don't think you need DNS but I think LES could be doing the job very well. That's my opinion.

Gostelow: We used LES also and that works very well in that situation. I agree with that.

Durbin: Just a general comment. In the CFD community people are working on the idea that we maybe should not treat it as black and white; that there are these methods, incorporating RANS, LES (DNS has not been discussed in this context) called hybrid methods, where certain parts of the flow have been treated by RANS, certain parts by LES and maybe those ideas could make it more practical. LES through the whole engine is not going to be ever feasible but 'different areas by different methods' is being worked upon.

van de Wall: Is there a different way to sensitize the turbulence model for these kind of flows? Is that something that we could do?

Durbin: The idea of detached eddy simulation is that the model will switch from RANS to LES where it seems to be appropriate.

van de Wall: I didn't hear anything about that in this conference. DES is not dead or anything?

Durbin: No. Not at all.

Gallimore: I would like to leave that question alone now otherwise we will spent the next fifteen minutes discussing whether DNS, LES or RANS is most appropriate. Well I would like to ask the academic community: We made four specific proposals. So I would like to have some feedback as to whether the academic community thought that was useful or whether we have wasted our time and whether what we propose, which is a bit more specific than last time, is actually feasible. The heat transfer stuff—we have to go away and do some work. I have to go away and clear those airfoils with Rolls-Royce so that we can present them to the rest of the world, I'm sure I could do that. Are people interested or what? So that's my question to the academic community.

Oldfield: There's an answer from one member of the academic community here.

Hodson: Just to respond to the suggestion to use Greg Walker's blade. We have actually just about finished building a 2D cascade of Greg's blade to put in a bar passing rig. So combined with the real full-scale experiments you have got the cascade experiments. All we need is some people to do some calculations.

Oldfield: Can I have more responses from the academic community.

Rodi: This was an interesting suggestion to do a DNS. I don't know the details. One would have to see how feasible it is. But then I think it would be very interested to do something like that.

Jeffries: I want to say that I appreciate the suggestions that industry gave for a couple of reasons. One because, in my job, I need to find and identify what basic research that academia is proposing would be relevant to the Air Force and in a lot of these cases this is exactly relevant as far as taking the



transitions and getting the product we want, getting the improvements we want, for the Air Force as much as for the rest of the industry. And so for me whether we do exactly those things is not important but the fact that you identify the areas to work on is important. And how we go about that, at least I know from where you are coming. So that's important.

I would like to add if I could that in our discussions it seems—and this is a key point that I'm hoping will come out in the proceedings—is that there has been a lot of discussion in our individual breakout groups, from what I have gathered, about how we transition technology. About how we work together or don't work together, between industry, academia and government. I'll throw government in the mix here because this is a critical thing and I think we are all recognizing that things have changed over the last few years. Not sure how long ago but the world from my perspective is different as far as how we do address the technology transitions and how we work together, or don't work together, to do that. And how the proprietary nature of things and the competitiveness has stifled in some ways some of the sharing of information, maybe that has always been there, but also how industry is working with academia, and sometimes circumventing government, and what role government should be taking with industry and academia. I'm not sure whether this is the right time to be making these comments but I think this is germane to this whole discussion.

Fasel: Responding to the comment that Paul made. I fully agree that the hybrid simulation approach that is being promoted by several of us is a very good idea, and I think it is particularly useful for turbomachinery applications. We have been developing what we call a 'flow simulation methodology' and the goal actually is to put us somewhere much closer to RANS than to LES. The problem with LES for your applications is that you need resolutions that are not too different from DNS to be useful and relevant. And that, of course, is way too expensive for industrial-type applications. So that is the motivation why we are developing that FSM and we have shown that you can get reductions in the required grids in orders of magnitude and we have just signed an agreement with FLUENT to incorporate it into the FLUENT code. So we will see how that works.

Okiishi: So, Ed White, I see that roughness has emerged above the sub layer. How are you going to do all this work? Alone, or are you going to build your team?

White: I think cloning experiments would be good value. It is really time consuming. I would be more than happy to get suggestions about what we tackle first, second, third in terms of specific geometries. If we say something beside sand grain, what the specific something's might be, would be really useful, just in terms of prioritization from your point of view about what is worth doing.

Okiishi: I should just add that, I don't think you mentioned this, but Ed will no longer be at Case. He's going to Texas A & M so his address is going to change in four months.

Yaras: This is a comment from the academic community. The roughness issue was raised by the industry panel as an important one. Ed's work is obviously a significant step in the right direction on that matter. But there is other work already that has been done recently by my group and by others so I think it highlights the point that Rhett made that it is important that the communication be improved amongst industry, academia and government because there is work out there and yet we think that we are at the preliminary stages in terms of roughness. I think we are much further ahead than what industry thinks we are at, so it is important that we communicate through appropriate channels so that the information is passed on. We are at the stage where we have models that can be put into RANS codes to capture the effect of roughness on transition. So it is important that industry is aware of that.

Sharma: From the industry panel. I think there are two things. One, the effect of surface roughness. I think Paul also mentioned that a model is available. We identified the test case, which is

Bammert and Milsch (1972, Gas Turbine paper). It would be worthwhile doing calculations on that. I found that the effect of surface roughness is that it stops the airfoils from having diffusion. The compressor loses the capability. I think you have to go and try to predict that. The effect on transition is pretty well known. It is the effect on the turbulent flow and the ability of the flow to diffuse. I think that's what we need to capture. That was the point I was trying to raise here. Two other things: One is the effect of surface curvature was identified by most of the groups. Surface curvature is important. The pressure side of the airfoil runs higher in heat transfer coefficient than we calculate. Fasel showed me some results that he was doing some DNS for the Pak B with and without surface curvature. His length of the laminar separation bubble is different by 30%. So somebody ought to go back and look at that again. So simulating pressure distributions on flat plates and on curved surfaces, the effects are different. One other thing is that when you go from a full scale cascade or airfoil to large scale experiments you cannot keep pressure distribution and curvature the same. The means you really need good physics-based models. We need to look at that again. One other thing I wanted to mention is that we identified test cases that were mostly rotating rigs. There is one other case - Langston's cascade. We have very detailed aerodynamics and heat transfer data. Some data I have at Pratt; we will release it all if someone is interested in it.

Katz: I just wanted to add to the comment about roughness. There is an enormous amount of work that has been made on roughness and is presently being made on roughness by several communities. Just from the Navy-sponsored turbulence program there is a substantial fraction of the activity involved with roughness, noise generated by roughness, modeling associated with this. I think that in that respect there is a message to the turbomachinery industry community, you should keep up with reading what's available.

Oldfield: Right. We are running out of time. Jean has been putting up his hand for the last five minutes.

Hourmouziadis: I thought I would try to change the subject. Somebody talked about the transportation of knowledge. I believe that the total knowledge possessed by the individuals in this room is about fifty times that that we will ever use. This is a social problem. For example the industry tends to separate design and research. But it is the designer who will pick up the research results, consider them for his design and incorporate them. Nobody else will do that. Talking about industry and academia, the best thing to do would be to send somebody from industry for half a year to a university and have them do some research and get the Professor to go into industry and design something. He will only then understand what can be done with the results of his research.

Okiishi: I'm not going to be flying any more if that happens (*laughter*).

Oldfield: Thank you Ted. Allan, would you like to just wrap up?

van de Wall: Thanks for everyone's comments. That's it.

Oldfield: It is extremely useful, especially to us in academia, to have this viewpoint. We now approach the end of the meeting and the last, and probably most important contribution, is the wrap-up discussion and I call on Roddam Narasimha to tell us what we have learnt today.

## WORKSHOP SUMMARY TRANSCRIPT

Roddam Narasimha  
Jawaharlal Nehru Centre for Advanced Scientific Research  
Indian Institute of Science  
Bangalore, India

If you don't mind I will sit down. The chief reason for that is that my material is on old and obsolete technology now, which are transparencies. We can't project them today and I would like to keep them in front of me as I speak. First of all let me say that it has once again been a great pleasure for me to be here, and to take part in this meeting and to listen to the many different viewpoints that have already been expressed. Particularly at this meeting I feel that there is now not a great deal that I can say because the discussion that has taken place, just before I started speaking, has gone into many issues in detail. In particular, comparing with previous meetings, I see that the interaction between the scientists and researchers who gather here, and industry, has become closer and stronger. Compared to Minnowbrook I, I believe we are now looking at much more specific issues than when we started.

The different panels have already made a variety of suggestions and the industry group has done that too. When we started this meeting, the industry panel picked on six themes; and I list them here just to see where we are in relation to the objectives that were identified. It is not in the same order as the one in which the industry panel listed them:

Unsteady interactions. Of course this meeting has been on "Unsteady flows in turbomachinery."

The panel talked about CFD modeling,

Heat loads, this was a big issue at the last meeting and continues to be,

Instability,

Flow control, and

LPT closure.

And at the beginning of this meeting the industry panel once again talked about joining up heat transfer and aerodynamics. The effect of roughness has also been talked about a great deal this morning, and the challenges of off-design conditions. Can we identify new concepts and develop them and are there new and simple experiments that we can define?

Now I have had the privilege of attending these Workshops right from the first one in the series. And it seems to me that the present meeting represents in some sense a kind of transition – a transition in the way that these meetings are going. I recall that when we first met, there was a considerable discussion of a certain kind of knowledge that had been built up within the academic community, and we were trying to relate it to the problems that occur in turbomachinery. It seems to me that thanks to these meetings we have come a considerable distance there, and now the point at which the academics or research scientists and industry meet has actually shifted closer and closer towards industry.

The other transition that I see in the meeting concerns the results from DNS. When we first started talking about it, and the first results were reported by Paul Durbin in Minnowbrook III, there was still considerable doubt whether DNS (a) was feasible, and (b) could illuminate what was happening. It now seems that that transition has occurred and at the present meeting there was no-one who raised that question. As a matter of fact what is more striking is that the position has changed. I think the reason is that the DNS results presented at this meeting were very impressive and I see that the industry panel also concurs in that assessment in terms of by-pass and separation-induced transition on compressor blades, the pictures that Paul Durbin showed about forward jets, reverse jets, and spots, the results that Wolfgang

Rodi had reported on both flow and heat transfer in turbine cascades, and the work that Hermann Fasel reported on the complicated interaction of transition and separation, on active control, and on how high two dimensional forcing can re-laminarize a transition bubble (an effect that incidentally is of the kind predicted by a dynamical-system model for open-flow turbulence, Bhat et al. 1996 *Phys. Fluids*). All of these I think are giving us insights that have come largely from DNS. These were ideas leading to concepts which I do not think were clear, not perhaps in every case but certainly in many cases, from earlier work. So the conclusion I have, from the DNS work that was reported at this meeting, is that its feasibility has now been demonstrated. Nobody questions now whether useful DNS can be done or not.

Of course there are difficulties that have not yet been sorted out. From my own point of view the big technical difficulty—mentioned but not sufficiently emphasized—is about the disturbance environment. If you want to make calculations on a realistic configuration, for example Greg Walker's diffuser, you need to be able to specify initial conditions, boundary conditions, and in particular the disturbance environment. If you wanted to make sure that the solution was grid-independent you might in fact have to go to much higher resolutions, as Hermann Fasel pointed out. It might well be that the situation will soon be reached where it is not so much whether we can solve the equations or not that is the problem, but whether we can set the problem up properly, with all the factors that will actually affect the solution. An experimenter knows this problem, and before he designs a set up he spends considerable effort deciding about what the conditions should be, whether the disturbance levels are low enough, whether the surface is smooth enough, and whether the quality of the flow is exactly what he wants in the sense that there are no extraneous factors that affect the results that he gets. Similar issues, I think, will become major concerns in further work on DNS.

There is also the question of resources, computing resources, human resources, post-processing, interpretation and so on. Hermann Fasel made a comment, with which I completely agree, "We do look at these pictures but I think many of the people that have been doing this, and are making the pictures themselves, know that what you see does depend on what you are looking for." So perhaps the results from these DNS simulations must actually be analyzed by more than one person, and should certainly not be limited to the scientists or groups that carried out the simulations. I think the same point was made by Paul when he said, "We need to do more data mining than data generation." Each DNS gives an enormous amount of data. I'm going to make a suggestion about that towards the later part of my presentation.

But going back to this change in view regarding DNS I would like to make the other point, which in fact was a theme which ran through all the presentations. From a scientific point of view it struck me that many of the people who reported work on unsteady effects: wake-shock interactions (Gorrell), wake-induced transition (Walker and many other people did that), wake-bubble interactions (Gostelow and Hodson), or the work that Hourmouziadis reported splitting the incoming flow into a mean velocity wake and a turbulence wake, wake-blade interactions, wake-wake interactions (Katz). Martin Oldfield presented a history of all the unsteady investigations at Oxford involving shocks and a variety of unsteady heat flux measurements. There are the unsteady horseshoe vortices on the pressure side of an airfoil on the end wall that Praisner talked about. Then there was off-design unsteady physics, and so on.

Now there was one theme running through many of these presentations, at the end of the presentation of the results—especially when some calculation was also involved. The theme seemed to be that if the unsteadiness is strong (and we would have to define what strong is), and sometimes even when it is not so strong (because in many cases this unsteadiness was not expected), steady CFD is not o.k., even for averages. Now here there is a subtle change in the meaning that we give to CFD already. It looks like DNS is being separated from CFD. CFD now seems to mean RANS or something similar rather than DNS. So, many people complain about steady CFD; what they really mean is that RANS, for example, isn't giving them the results that they are looking for. And I see a thread of comment running through

many of these presentations where they say, “We should do LES, or DNS.” So this is the changing view that I am trying to highlight.

Now eventually one of course will not be able to do DNS for all the problems that one needs to tackle, for that is far too much information. And as has been emphasized even this morning, the results of this DNS would have to be converted by analysis into insight, into understanding, into a feeling for the physics, so that eventually it becomes part of our thinking rather than that we need to do a DNS every time. So we will still need a hierarchy of models, DNS, LES, RANS and so on, and the kind of hybrid methods that Paul also mentioned a little while ago. So one does this kind of computing with two different kinds of objectives. One has to do with numbers, prediction, and the other has to do with insight. And we need to do computing for both. We need to derive insight from computing, we need to derive numbers as well. But it need not necessarily be the same kind of computing for both of them, and that is why a hierarchy of models is required.

Let me now go back to the agenda for this meeting that was set at the last Minnowbrook Workshop, as well as earlier when we started out on the Sunday and the first session on Monday. The theme that was most striking to me was about heat transfer. At the last meeting there was considerable discussion about the subject: about unsteady heat fluxes, about hot spots, about how the highest heat flux can be very much larger than what you would normally calculate for example by a RANS method. When the results were actually presented on heat transfer, they were combined in certain cases with the aerodynamics, along the lines that the industry panel was saying would be very useful to do. Langston pointed out, for example, that Reynolds analogy does not work. Of course we have known, from many experiments, that Reynolds analogy is by no means always something that you can use reliably. There were questions about end-wall heat transfer, and how steady CFD is not satisfactory. Michael Dunn pointed out how when you do aerodynamics and heat transfer together modeling is actually difficult. And that point was made again and again. It was also made by Reza Abhari in his very comprehensive review at the beginning of the meeting.

The next conclusion that I draw from the presentations that were made on heat transfer is that on the whole, compared to the extraordinary importance of the subject in turbine design, at least as I see it, the total amount of work being done where heat transfer is a primary variable is still too small. From the point of view of the applications that have been highlighted in these meetings, we know there is a huge interest in heat transfer. I am not talking about that. I am talking about the specific points made about unsteady heat fluxes and the very large values that you can get locally and instantaneously in many turbine applications. Wolfgang of course had both heat transfer and aerodynamics/fluid mechanics in his simulations. But he did have a problem in simulating the heat transfer. Now that might have been due, he suggested, to the wakes that were used. But once again this shows how important it is to set the problem up with the right kind of disturbance environment, the right kind of inlet conditions, for one to be able to get reliable results.

**Stability.** This is an area where only a few presentations were made, but they were very useful, very insightful. There was the work that Theofilis presented, with bubble modes and wake modes and BiGlobal analysis. And Hermann Fasel combined, in a very interesting way, stability analysis with his DNS results. It seems to me that eventually, in a large number of unsteady flows, insight is going to be derived by combining thinking about stability with the results that one may get from very elaborate calculations. In the final analysis I think stability plays a greater role than we often believe it does. Stability is not just a set of calculations to be made as a preliminary to making a transition prediction: there is a great deal more to it. There is probably a great deal to stability even in turbulent flows, especially as we know there are coherent structures and, although the total energy contained in these coherent structures is not very large, both from the point of view of control and from the point of view of insight, understanding the stability considerations that lead to those structures, I think, is very important.

So, although it may seem slightly removed from the considerations that industry has about design, stability thinking should, whenever possible, be incorporated with the analysis of the data that we get from any of these simulations, DNS, LES whatever.

There was a lot of other work, on acoustic resonance, on spots, on roughness. Ed White had some interesting results. Various comments, as I already mentioned, were made on CFD modeling. In relation to the list that the industry panel had prepared, we had little bits of most of those things, some with considerable insight and relevance. To that extent I think that this meeting has been a very great step forward.

Well, what about the future? Specific projects for the future have already been suggested earlier this morning, both by the break-out groups and by the industry panel.

There are many questions: about how we do it, where we get the people, how we make the interactions between academic/research scientists and industry closer, and what the problems are that we need to tackle. Now the first problem, which has been very squarely faced for the first time in this meeting, has to do with the data and the results in the possession of industry. We have been told that industry can actually do a lot of these things. They have codes, 3D codes for example, they have correlations. That may well be so, and if that is so the academic scientist must ask himself, "What is it that I can do there to help this along"? If a subject is under control, well, then academics should surely look at something else. An academic who looks at a subject that is under control is not doing his job: he must be looking at things which are not understood. So, defining the precise role that is there for an outsider in this situation is a bit difficult. Maybe insiders in industry can define that more precisely than an outsider can do.

But let me go back to some of the things that can be done. Let me begin once again with high resolution DNS. Now Hermann said he uses 200 million grid points and there are others using maybe one tenth or one fifth of that. And if you wanted to be sure that you had a grid-independent solution I know from my own personal experience that the resolution required is sometimes huge. I tried to work on a cavity problem once, and I found that the resolution required if I wanted to know the flow near the wall accurately was almost astronomical at any Reynolds number that was not too small. I think that we might have to find a method for doing these DNS studies in a somewhat different way. I want to make a radical suggestion. Because these demand huge resources, computing as well as human, it might be worthwhile to define a few projects where one or a few people get together, set the problem up properly, with due consideration of all the appropriate initial conditions, boundary conditions, inlet conditions and so on, carry out the solution and make it available openly in public for analysis. Maybe one should do it like a small satellite project. In such a project the design itself takes a great deal of time. The principal scientists on the project get the first look at the data. But after a year or some such time the data is thrown open. Anyone can look at it, interrogate it and do the kind of data mining that Paul Durbin was talking about. So maybe we should have one or two projects of that kind. Maybe on the diffuser, as was suggested by industry; there maybe other candidates. Experimentalists quite often do this. One example that comes to my mind is the Princeton experiments on the super pipe at very high Reynolds numbers (of the order of  $10^7$ ). Anybody can now look at the data. It is of great interest to find that the same data has been analyzed in at least half a dozen significantly different ways by different people—and with scientific conclusions that are diverse. So some open DNS results could be of great value.

One thing that became very clear from this meeting is that DNS is not going to solve all our problems, I think we've always known that. Therefore the role of other forms of CFD and experiment will still remain very strong.

Another idea that I would like to endorse goes back to a suggestion that Jean made on the first day with particular reference to heat transfer. This is the desirability of organizing a Stanford type conference. I

don't know how many of you took part in the first conference which took place in 1967. I was at the second one in 1981–82, and actually the first one too, in some sense. It was a major effort which was undertaken at a time when the kind of things that are now being talked about in terms of the uncertainties of heat flux measurements were there in respect of skin friction coefficients and turbulent boundary layer characteristics, even in two dimensional flow. I remember that a large number of people worked very hard, for more than a year before the meeting, consolidating the data, making them available for other people to analyze, identifying targets for prediction, etc. I remember that Don Coles wrote a very useful and illuminating little booklet called "A Young Person's Guide to the Data." We probably now need a young person's guide to the data on heat transfer: not the standard kind of heat transfer data you find in textbooks and so on but those relevant to turbomachinery applications with an emphasis on unsteady heat transfer.

And at that time many people were invited to make 'post-dictions' for data that had already been acquired experimentally and had been 'certified' by analysis groups. And then there were committees that looked at the post-dictions made by all the different models, grouped them into different classes and, although not everyone would agree with that classification, I think it led to a great deal of insight and resulted in a distinct advance in the way these problems were handled. Something like that today, involving RANS, LES, DNS results for some standard heat transfer cases, experimentally measured, might be a very good thing to do. It is of course a major effort, but if someone is willing to undertake it I think it would be highly worthwhile.

There was also some discussion about blade and airfoil design. Once again this is an area where it looks as if a lot of the information is proprietary and one has to ask oneself the question, "What is it that outsiders can do"? Dr. Povinelli mentioned that there is a resurgence of interest in aeronautical research at NASA, and maybe this resurgence could be made use of to see if certain standard blade and airfoil designs could be made open. These are not necessarily the ones that industry is actually using in their turbines. One can visualize the kind of catalogs that NACA so famously produced on airfoils for external aerodynamics, still used quite often. So once again that is something there that might be a useful thing to do.

One thing I discovered here, I didn't know before I came to this meeting. This is that the possibility for new kinds of RANS models has not been exhausted. Particularly what Wolfgang Rodi has been talking about—Menter's model. Whether it works well or not, there is an approach there which is something that one should look at because in many of these flows now, the standard turbulent boundary layer concept, with a given free-stream velocity at the edge, does not apply. So you need a somewhat different kind of modeling. So I think that an assessment of such models, in situations that are relevant to turbomachinery, would be very interesting.

On end wall flows, there were several interesting presentations. Once again suggestions were made that LES or DNS might be necessary for being able to compute those flows with any accuracy, and that RANS models of the type that are now being used are not good enough. That might be one candidate for a DNS or LES calculation.

The other area that was highlighted in these presentations earlier was flow control. There have been some very interesting developments here. Tom Corke, Hermann Fasel and others have presented results there with the possibility of passive control using fillets for example, like Karen Thole described, and there is the very important and interesting problem of finding out if there are "sweet spots" in the flow. A sweet spot is one where application of a small force could, in fact, have a disproportionately large effect on the total flow. This is the other side of the theory of chaos—that small changes that you make in certain areas of the flow could have large effects elsewhere—possibly everywhere. We know that such situations do

occur. For example Strykowski & Sreenivasan (1990 JFM) showed that the Karman vortex-street behind a circular cylinder can be suppressed by putting a little wire somewhere else but the spot where you put it is extremely important. So I think that even academic investigation of such flow control problems can give us considerable insight into what we may actually be able to do.

There was also discussion about flutter, oscillating blades and related subjects.

One thing about heat transfer that I did not mention was this. I think it was Om who said that a 20 degree difference in temperature makes a 50% difference in life; many other statements about heat transfer of that kind were also made. What that suggests is that a great deal more sensitivity studies are required. What are the things that actually affect heat transfer? Once again the people in industry may know all of this already. They must to some extent, because they are already making those systems and flying them. But from a scientific point of view it would be very useful to identify those parameters, whether it is the surface temperature, or the coupling between the surface and the flow, or inlet conditions, or roughness, or whatever else. It would be very interesting to have an overall study of what instantaneous heat flux values are sensitive to, in terms of all the different parameters that affect the flow.

Well, I think I could go on like this but I should really conclude. My time is up and anyway I have said everything that I wanted to say. I think that there are a great many possibilities. To repeat what I said earlier, it seems to me that this meeting does represent a kind of a transition, from a position where people were uncertain about what DNS could do, to one where it is now getting integrated into their thinking. I think this is an excellent development. I think we can look forward during the coming years to more work along those lines; to more interaction with industry. I go back to what the industry panel said last time, maybe I didn't hear it so often this time: namely that eventually it is understanding which is extraordinarily useful. And I think there are many projects that one can identify, from what was presented here, that could lead to such an enhancement of our understanding and therefore I think that people who are doing research have a great deal that they can look forward to doing.

Thank you all very much, particularly John and Paul for making it possible for me to come here for these three days of very interesting discussion.

Oldfield: Thank you very much Roddam. We have an unscheduled contribution from Paul Gostelow.

Gostelow: Thanks Martin. This is about Roddam. Roddam said to me last night, "You know, this is the last Minnowbrook I'm going to be able to come to. Twenty hours of flying is getting too much." Well it is, for all of us, it's too much. And I think I've heard Roddam say that before, and I may be wrong so that's the hope. Well we hope it's not the last Minnowbrook that he comes to but if it is, just in case, I'm going to say thank you very much for your singular efforts to this meeting over the years, Roddam, right from the beginning in 1993. And we've used Roddam in pretty much the same way all along except that in the earlier years he also fired us up, gave us the hellfire and damnation kind of sermon that got us all going. But at each meeting he has concluded things in the way that he has just done right now, issuing challenges, probing, all the time probing, helping us to pull our thoughts together about the meeting, making it all make sense for us and issuing new challenges. A typical example would be that meeting when he said O.K. Next meeting I would like someone to have produced a DNS for a turbine blade, with wakes coming through. And we all laughed and said, "Yes. Funny. Good joke. You get the bottle of wine." And went away. And most of us did nothing. Paul Durbin didn't do nothing—he did it and produced it at the next meeting. And the next meeting Wolfgang had done the same thing and so on. That is just a typical way in which lots of progress has been made from this meeting and it has only really happened because Roddam has gathered the thoughts together and made sense of them and issued them in the form of fairly specific, pointed, challenges and so on. I think his role has been utterly invaluable. I



think Minnowbrook would not exist probably if it weren't for Roddam's summaries and guiding hand behind the whole lot. So without saying any more I would just like us to move a vote of thanks and say thank you very much to Roddam for your contributions over the years. We hope it is not the last.

Oldfield: We are approaching the end of the wrap up session and John LaGraff is going to finish it up but can I just make a few comments? I'm a Minnowbrook virgin. It's my first time here and I thought I would just make a few comments on the meeting. One goes to meetings and I have a scale of how you evaluate a meeting. There are a lot of "no new idea" meetings, where you go and you come back and you think, "that was interesting, but." Then occasionally there are "one good new idea meetings" where you come back and think and act; really good ones there are two new ideas. This meeting I've been overwhelmed. I think we are two orders of magnitude or so above that. This is a "multi-idea meeting" and I personally have been honored to be here and to be among such expertise, industry and university eyeball to eyeball, which I think is very productive. I've enjoyed this meeting hugely but I would like to just say that John you have been the well-spring, the instigator, the mover of these meetings and I've had the pleasure of watching you organize this one and I think that we owe you a vote of thanks for all you have done in organizing these meetings. Can I pass a vote of thanks to John?

LaGraff: Those comments were not on the schedule so I am not sure whether we have recorded them or not! Thank you. I would like to echo Paul's comments on Roddam. We really appreciate your participation. He's been at every Minnowbrook and I think his contributions have set the theme and the tone of the whole workshop, output and activities. I would like to thank everyone here for attending. I know it takes a chunk of time out of your holidays, or summer, or preparation for the new academic year or your industrial projects and we appreciate that. We especially appreciate the continued sponsorship that we've been able to get from AFOSR, Rhett Jefferies has continued that, and the support and suggestions we received from Lou Povinelli and David Ashpis of NASA Glenn. We also greatly appreciate the travel support we received from Surya Surampudi of the European Office of Aerospace Research and Development and Tae-Woo Park of the Asian Office of Aerospace Research and Development of the USAFOSR Window-on Science Program, providing the support that makes the cost of attendance relatively low, including the travel support that we are able to get for some of our visitors from overseas. We welcome your comments, by email afterwards, if you have any suggestions we are always fine-tuning the format and the topic a little bit each time. We continue to welcome your input, of suggestions you can make about themes, format, structure or if you would like better weather next time, any comment like that we will try to do something about. Thank you all again for attending.



## List of Participants

**Reza Abhari**

ETH/Zurich  
Turbomachinery Lab  
Switzerland  
rabhari@ethz.ch

**John Clark**

Air Force Research laboratory  
AFRL/PRTT  
Turbine Branch  
john.clark3@wpafb.af.mil

**Paul Durbin**

Iowa State University  
College of Engineering  
durbin@iastate.edu

**Hermann Fasel**

University of Arizona  
Aerospace & Mechanical  
Engineering  
faselh@u.arizona.edu

**Jochen Gier**

MTU Aero Engines GmbH  
Tubinaerodynamik  
Germany  
jochen.gier@muc.mtu.de

**Paul Gostelow**

University of Leicester  
Dept. Of Engineering  
UK  
jpg7@leicester.ac.uk

**Brian Holley**

University of Connecticut  
Mechanical Engineering  
langston@enr.uconn.edu

**Joseph Katz**

The Johns Hopkins University  
Dept. of Mechanical Engineering  
katz@titan.me.jhu.edu

**Roddam Narasimha**

Indian Inst. of Science  
National Institute of Adv.  
Studies  
India  
roddam@caos.iisc.ernet.in

**Jeff Bons**

Brigham Young University  
jbons@byu.edu

**Tom Corke**

University of Notre Dame  
Aerospace & Mechanical Engr.  
Dept.  
tcorke@nd.edu

**Karl Engel**

MTU Aero Engines GmbH  
Compressor Division  
Germany  
karl.engel@muc.mtu.de

**Torsten Fransson**

EKV/KTH  
Department of Energy  
Technology  
Sweden  
Torsten.Fransson@energy.kth.se

**Mark Glauser**

Syracuse University  
Mechanical & Aerospace  
Engineering  
mglauser@syr.edu

**Frank Haselbach**

Rolls Royce Deutschland  
Turbine Aerodynamics  
Germany  
frank.haselbach@rolls-royce.com

**Jean Hourmouziadis**

Technische Universitat Berlin  
Institut fur Luft-und Raumfahrt  
Germany  
hourmouziadis@tu-berlin.de

**John E. LaGraff**

Syracuse University  
Mech. & Aerospace Engineering  
jlagraff@syr.edu

**Ted Okiishi**

Iowa State University  
College of Engineering  
tedo@iastate.edu

**Dave Car**

Air Force Research laboratory,  
AFRL/PRTT  
Propulsion Directorate  
david.car@wpafb.af.mil

**Michael Dunn**

Ohio State University  
Department of Aerospace Eng.  
& Aviation  
dunn.129@osu.edu

**John Fabian**

NASA Glenn Research Center  
john.fabian@grc.nasa.gov

**Simon Gallimore**

Rolls Royce Derby  
UK  
simon.gallimore@rolls-royce.com

**Steven Gorrell**

Air Force Research Lab  
AFRL/PRTF  
Propulsion Directorate  
steven.gorrell@wpafb.af.mil

**Howard Hodson**

Cambridge University  
Whittle Lab  
UK  
hph1000@cam.ac.uk

**Rhett Jeffries**

AFOSR  
rhett.jefferies@afosr.af.mil

**Lee Langston**

University of Connecticut  
Mechanical Engineering  
langston@enr.uconn.edu

**Martin Oldfield**

Oxford University  
Osney Labs, Engineering  
Science  
UK  
martin.oldfield@eng.ox.ac.uk

**Lou Povinelli**  
NASA Glenn Research Center  
Turbomachinery and Prop  
Systems  
Louis.a.povinelli@grc.nasa.gov

**Joerg Seume**  
Leibniz Universität Hannover  
Institute for Turbomachinery  
Germany  
seume@ifs.uni-hannover.de

**Vassilis Theofilis**  
Technical University of Madrid  
Spain  
vassilis@torroja.dmt.upm.es

**Greg Walker**  
Univ. of Tasmania  
School of Engineering  
Tasmania, Australia  
greg.walker@utas.edu.au

**Thomas Praisner**  
United Technologies Pratt &  
Whitney  
Turbine Aerodynamics  
thomas.praisner@pw.utc.com

**Om Sharma**  
United Technologies Pratt and  
Whitney  
sharmaop@pweh.com

**Karen Thole**  
Penn State University  
Mechanical and Nuclear Eng.  
Dept.  
kthole@mne.psu.edu

**Ed White**  
Case Western Reserve Univ.  
Dept. of Mech and Aerospace  
Engineering  
ebw@po.cwru.edu

**Wolfgang Rodi**  
University of Karlsruhe  
Institute for Hydromechanics  
Germany  
rodi@uka.de

**William Solomon**  
General Electric Aviation  
william.solomon@ae.ge.com

**Allan Van Dewart**  
General Electric Aviation  
allan.vandewall@ae.ge.com

**Metin Yaras**  
Carleton University  
Dept. of Mech. & Aerospace  
Engr.  
Canada  
Metin\_Yaras@carleton.ca



**REPORT DOCUMENTATION PAGE**Form Approved  
OMB No. 0704-0188

Public reporting burden for this collection of information is estimated to average 1 hour per response, including the time for reviewing instructions, searching existing data sources, gathering and maintaining the data needed, and completing and reviewing the collection of information. Send comments regarding this burden estimate or any other aspect of this collection of information, including suggestions for reducing this burden, to Washington Headquarters Services, Directorate for Information Operations and Reports, 1215 Jefferson Davis Highway, Suite 1204, Arlington, VA 22202-4302, and to the Office of Management and Budget, Paperwork Reduction Project (0704-0188), Washington, DC 20503.

<b>1. AGENCY USE ONLY (Leave blank)</b>		<b>2. REPORT DATE</b> December 2006	<b>3. REPORT TYPE AND DATES COVERED</b> Conference Publication	
<b>4. TITLE AND SUBTITLE</b> Minnowbrook V 2006 Workshop on Unsteady Flows in Turbomachinery			<b>5. FUNDING NUMBERS</b>  WBS 561581.02.08.03.02.01	
<b>6. AUTHOR(S)</b> John E. LaGraff, David E. Ashpis, Martin L.G. Oldfield, and J. Paul Gostelow, editors				
<b>7. PERFORMING ORGANIZATION NAME(S) AND ADDRESS(ES)</b> National Aeronautics and Space Administration John H. Glenn Research Center at Lewis Field Cleveland, Ohio 44135-3191			<b>8. PERFORMING ORGANIZATION REPORT NUMBER</b>  E-15776	
<b>9. SPONSORING/MONITORING AGENCY NAME(S) AND ADDRESS(ES)</b> National Aeronautics and Space Administration Washington, DC 20546-0001			<b>10. SPONSORING/MONITORING AGENCY REPORT NUMBER</b>  NASA CP-2006-214484	
<b>11. SUPPLEMENTARY NOTES</b> Abstracts and viewgraphs prepared for the Minnowbrook V-2006 Workshop on Unsteady Flows in Turbomachinery sponsored by Syracuse University, Blue Mountain Lake, New York, August 20-23, 2006. John E. LaGraff, Syracuse University, Syracuse, New York 13244; Martin L.G. Oldfield, University of Oxford, Oxford OX1 3PJ, U.K.; and J. Paul Gostelow, University of Leicester, Leicester, LE1 7RH, U.K. Responsible person, David E. Ashpis, organization code RTT, 216-433-8317.				
<b>12a. DISTRIBUTION/AVAILABILITY STATEMENT</b> Unclassified - Unlimited Subject Categories: 02, 07, and 34 Available electronically at <a href="http://gltrs.grc.nasa.gov">http://gltrs.grc.nasa.gov</a> This publication is available from the NASA Center for AeroSpace Information, 301-621-0390.			<b>12b. DISTRIBUTION CODE</b>	
<b>13. ABSTRACT (Maximum 200 words)</b> This volume and its accompanying CD-ROM contain materials presented at the Minnowbrook V-2006 Workshop on Unsteady Flows in Turbomachinery, held at the Syracuse University Minnowbrook Conference Center, New York, on August 20-23, 2006. The workshop organizers were John E. LaGraff (Syracuse University), Martin L.G. Oldfield (Oxford University), and J. Paul Gostelow (University of Leicester). The workshop followed the theme, venue, and informal format of four earlier workshops: Minnowbrook I (1993), Minnowbrook II (1997), Minnowbrook III (2000), and Minnowbrook IV (2003). The workshop was focused on physical understanding of unsteady flows in turbomachinery, with the specific goal of contributing to engineering application of improving design codes for turbomachinery. The workshop participants included academic researchers from the United States and abroad and representatives from the gas-turbine industry and U.S. Government laboratories. The physical mechanisms discussed were related to unsteady wakes, active flow control, turbulence, bypass and natural transition, separation bubbles and turbulent spots, modeling of turbulence and transition, heat transfer and cooling, surface roughness, unsteady CFD, and DNS. This volume contains abstracts and copies of the viewgraphs presented, organized according to the workshop sessions. Full-color viewgraphs and animations are included in the CD-ROM only. The workshop summary and the plenary discussion transcripts clearly highlight the need for continued vigorous research in the technologically important area of unsteady flows in turbomachines.				
<b>14. SUBJECT TERMS</b> Turbomachinery; Transition; Turbulence; Wakes, Boundary layers; Turbulent spots; Active flow control; Heat transfer; Unsteady flow; Compressors; Turbines			<b>15. NUMBER OF PAGES</b> 120	
			<b>16. PRICE CODE</b>	
<b>17. SECURITY CLASSIFICATION OF REPORT</b> Unclassified	<b>18. SECURITY CLASSIFICATION OF THIS PAGE</b> Unclassified	<b>19. SECURITY CLASSIFICATION OF ABSTRACT</b> Unclassified	<b>20. LIMITATION OF ABSTRACT</b>	



