

IAA-B6-0706P

THE CALIPSO THERMAL CONTROL SUBSYSTEM

Joseph F. Gasbarre

Structural and Thermal Systems Branch
NASA Langley Research Center
1 N. Dryden St., Hampton, VA
Phone: +01 757 864 7035, Joseph.F.Gasbarre@nasa.gov

Marc Valentini

Alcatel-Alenia Space, Cannes, FR

Jason Thomas

Ball Aerospace and Technology Corp., Boulder, CO

Wes Ousley

NASA Goddard Space Flight Center, Greenbelt, MD

Joel Dejoie

Centre National D'Etudes Spatiales (CNES), Toulouse, FR

ABSTRACT

The Cloud-Aerosol Lidar and Infrared Pathfinder Satellite Observation (CALIPSO) is a joint NASA-CNES mission to study the Earth's cloud and aerosol layers. The satellite is composed of a primary payload (built by Ball Aerospace) and a spacecraft platform bus (PROTEUS, built by Alcatel Alenia Space). The thermal control subsystem (TCS) for the CALIPSO satellite is a passive design utilizing radiators, multi-layer insulation (MLI) blankets, and both operational and survival surface heaters. The most temperature sensitive component within the satellite is the laser system. During thermal vacuum testing of the integrated satellite, the laser system's operational heaters were found to be inadequate in maintaining the lasers' required set point. In response, a solution utilizing the laser system's survival heaters to augment the operational heaters was developed with collaboration between NASA, CNES, Ball Aerospace, and Alcatel-Alenia. The CALIPSO satellite launched from Vandenberg Air Force Base in California on April 26th, 2006. Evaluation of both the platform and payload thermal control systems show they are performing as expected and maintaining the critical elements of the satellite within acceptable limits.

1.0 INTRODUCTION

The Cloud-Aerosol Lidar and Infrared Pathfinder Satellite Observation (CALIPSO) is a joint NASA-CNES mission to study the Earth's cloud and aerosol layers from a sun-synchronous, 705 km orbit for a period of three years. The primary instrument on CALIPSO is a LIDAR, which includes an Integrated Laser Transmitter (ILT) that contains two lasers and a primary receiving telescope. Secondary instruments include a Wide-Field Camera (WFC) and Imaging Infrared Radiometer (IIR). In addition to the main instruments, the payload consists of a Payload Controller (PLC), X-Band transmitter system, associated electronics, and the payload structure. There is also a platform star tracker assembly (STA) mounted to the payload. This integrated payload is mounted as a single unit onto the PROTEUS platform.

The thermal control subsystem (TCS) for the CALIPSO satellite is a passive design utilizing radiators, multi-layer insulation (MLI) blankets, and both operational and survival surface heaters. The PROTEUS platform TCS is required to control temperature sensitive components within the bus such as the satellite batteries, propulsion system, and the main computer, or Data Handling Unit (DHU). For the payload, several items require active operational heaters. The most temperature sensitive is the laser system. Only one laser is operated at a time with the second laser providing redundancy. Each laser's temperature set point is controlled with an operational heater contained within each laser. Additionally, a bus-controlled survival heater is attached to the bottom of each laser unit in close

proximity to the operational heaters for use when the instrument is powered off or in an otherwise non-operating mode.

The CALIPSO satellite launched from Vandenberg Air Force Base in California on April 26th, 2006. Following placement in orbit, the PROTEUS thermal control system was activated to provide support for both the platform and payload while the satellite was fully-powered and exercised. After the initial check-out period, the payload was slowly brought online and the associated thermal system activated. Evaluation of both the platform and payload thermal control systems shows they are performing as expected and maintaining the critical elements of the satellite within acceptable limits. After final post-launch thermal evaluation, an estimate of the thermal performance of the payload through the end of the mission was performed, including an estimate of effective laser system control.

2.0 PROTEUS PLATFORM

PROTEUS [1] is a multi-mission platform developed in partnership between Alcatel Alenia Space and CNES. It aims to cover a wide range of LEO missions with a wide range of flexibility in terms of altitudes, orbit inclinations, attitudes, and launch vehicle compatibility while maintaining reduced costs and schedules. For each mission, the flexibility of the thermal control has to involve only minor modifications such as SSM radiator sizes or heating parameters. The satellite JASON-1 (successor of Topex/Poseidon) launched in December 2001 was the first application of the PROTEUS platform. Thanks to this successful flight operation, five other PROTEUS platforms have been contracted. These platforms will benefit from developments to bear the heavier and more dissipative payloads to be launched between 2006 and 2008. CALIPSO is the first Satellite which benefits from these improvements.

The PROTEUS platform is based on a 1m³ cubic structure (Figure 1), and includes:

- Four lateral panels for equipment units, fixed to the tubular frame on [+/-Ys] and [+/-Zs]
- Two symmetrical solar array wings on [+/-Ys]
- A propulsion panel on [-Xs] side supporting the hydrazine tank to separate the equipment zone from the propulsion zone (tubing, thrusters)
- Launcher interface ring on the bottom of the platform depending on launcher ([-Xs] side)
- Bottom frame allowing an I/F between the Satellite tubular frame and the launcher ring.
- 1 top panel for Payload I/F on [+Xs] side
- The Star Tracker Assembly (STA) is located on the [-Zs] payload panel (see Figure 5)

2.1 THERMAL SYSTEM DESCRIPTION

The thermal control concept is based on 5 uncoupled zones [2]:

- Battery (operating range: 15°C to +35°C)
- Platform equipment units (-20°C to +50°C)
- Propulsion subsystem (+10°C to +50°C)
- Star Trackers (for mechanical reasons)
- Payload (to allow separate thermal sizing)

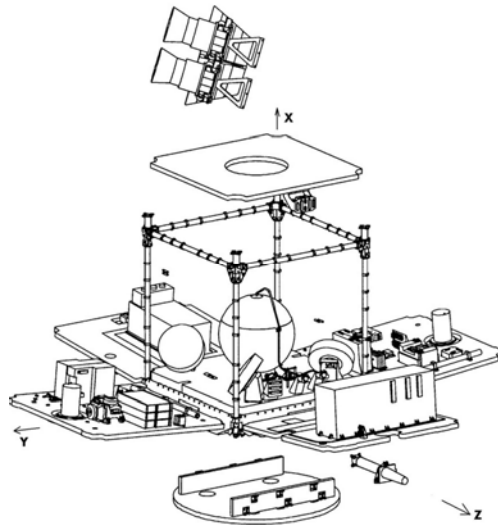

Figure 1: PROTEUS Platform Layout

The passive thermal control components used on PROTEUS are of classical heritage, such as silvered SSM on radiators, external and internal MLI, permaglass thermal insulating washers, aluminum doublers, and white paint and gold finishing on the L/V adaptor. The generic active thermal control can provide 10 regulated heater lines for use by the platform and 11 regulated heater lines for the payload. This scheme provides very good performance in terms of thermal stability and precision. Nevertheless, the choice of such a concept is mainly driven by adaptability and flexibility needs which are important not only during the development phase but also during flight (via command uploads). For CALIPSO, the platform equipment dissipates between 220 and 310 Watts in the operational phase and between 180 and 250 Watts in the survival phase.

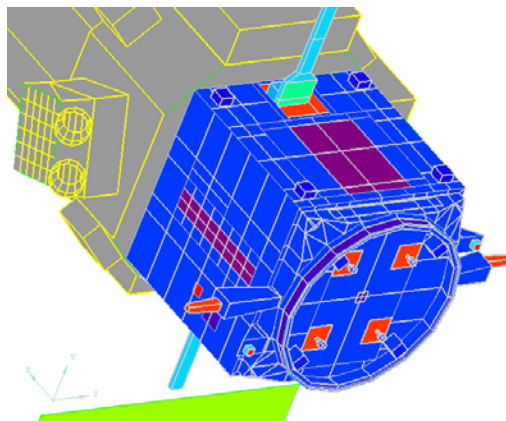

Figure 2: CALIPSO Platform Radiative Thermal Model

2.2 ANALYSIS AND TESTING

In order to predict the thermal behavior of the CALIPSO platform, estimate the radiative surface position, and foresee the heating power needs for the mission, the PROTEUS 750 thermal model was adapted to this specific mission and used to perform numerical simulations. Figure 2 shows the radiative thermal model built using AAS Coratherm thermal software. Due to the thermal decoupling of the platform from the payload and other external assemblies, it is not necessary to build an

integrated model to perform the platform STA assembly sizing. This allows a minimum amount of thermal interface calculations without over sizing the thermal control needs.

The thermal tests on CALIPSO platform were performed at the Satellite level. These tests were split into 2 phases: a thermal balance test (to validate the changes on the platform thermal control due to the specific mission and adjust the parameters of the heater control system) and a cycling test (to check the performance of the satellite operation in the worst-case thermal conditions). The Satellite was successfully tested during balance and cycling tests at Alcatel Alenia Space-Cannes (France) in August 2004. Using data from this test, the platform thermal model was correlated to test results from the 3 balance test cases to within 2°C for each node.

2.3 ON-ORBIT PERFORMANCE

The thermal control flight assessment performed since the CALIPSO launch shows the platform thermal control system performing as expected and all equipment is within specified temperature ranges. The heater line temperature set points are well tuned to protect all equipment from their minimum temperature limits and heater power draw is as expected. CALIPSO temperature profiles show that thermal control for many components is more accurate than expected. Thus, the propulsion system has a thermal stability of $\pm 0.2^{\circ}\text{C}$ (Figure 3) and the battery panel a stability of $\pm 0.3^{\circ}\text{C}$ (Figure 4) instead of the predicted $\pm 1^{\circ}\text{C}$.

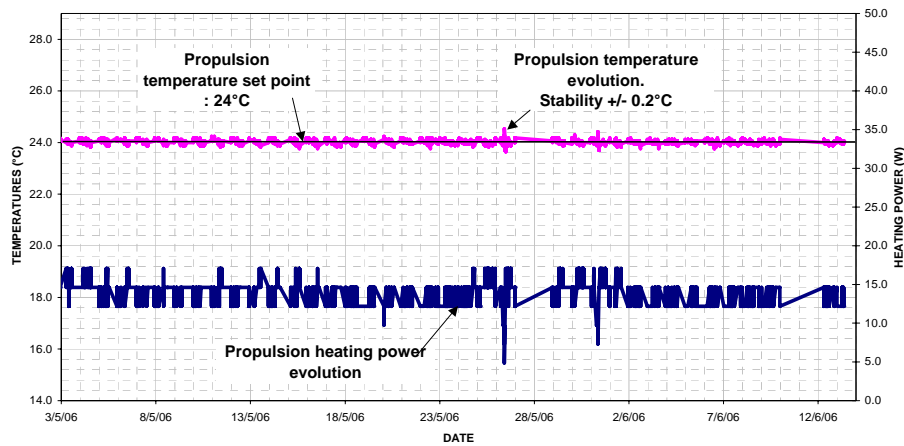

Figure 3: CALIPSO Propulsion Panel Thermal Profile

However, the STA model is not very precise; the predictions are too warm compared to the flight results from 5°C to 7°C. This model was reviewed during the satellite thermal test on the Corot Satellite (June 2006). Internal radiative exchange is now taken into account which involves a decrease in temperature and better predictions. The model now shows good results as can be seen in the flight results of the Corot Satellite launched on December 27th 2006.

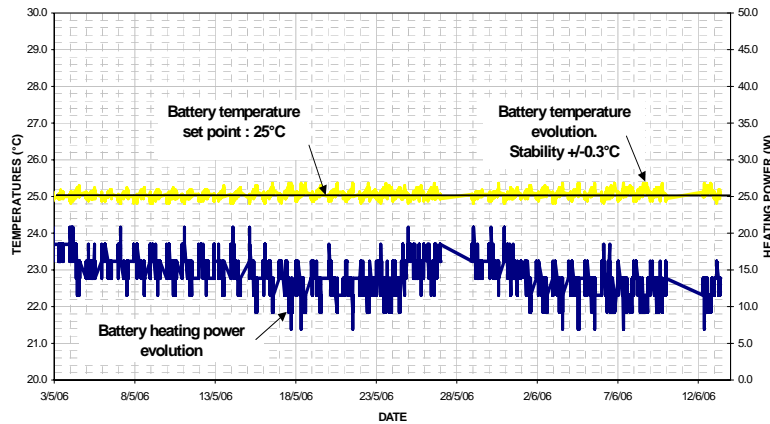

Figure 4: CALIPSO Battery Thermal Profile

3.0 PAYLOAD

The CALIPSO payload is a composite structure built from M55J fibers and consists of three separate assemblies: optical bench, payload housing, and lightshade. The thermal conductivity of M55J fibers is approximately 30 W/m-K, which is 1/6th the value of aluminum. Due to this low thermal conductivity, it is difficult to transport heat across the structure to dedicated radiators. Therefore, each major heat source except the X-Band Transmitter is thermally isolated from the structure and has a dedicated control system (MLI, survival heaters, and radiator surfaces). Due to the transient nature of the X-Band Transmitter power it is necessary to thermally couple the transmitter with the payload housing through a thermal gasket. Power sources on the optical bench radiate heat to the inner walls of the payload housing which in turn dumps heat to space through two dedicated radiator surfaces (+Y/+Z and +Y/-Z surfaces).

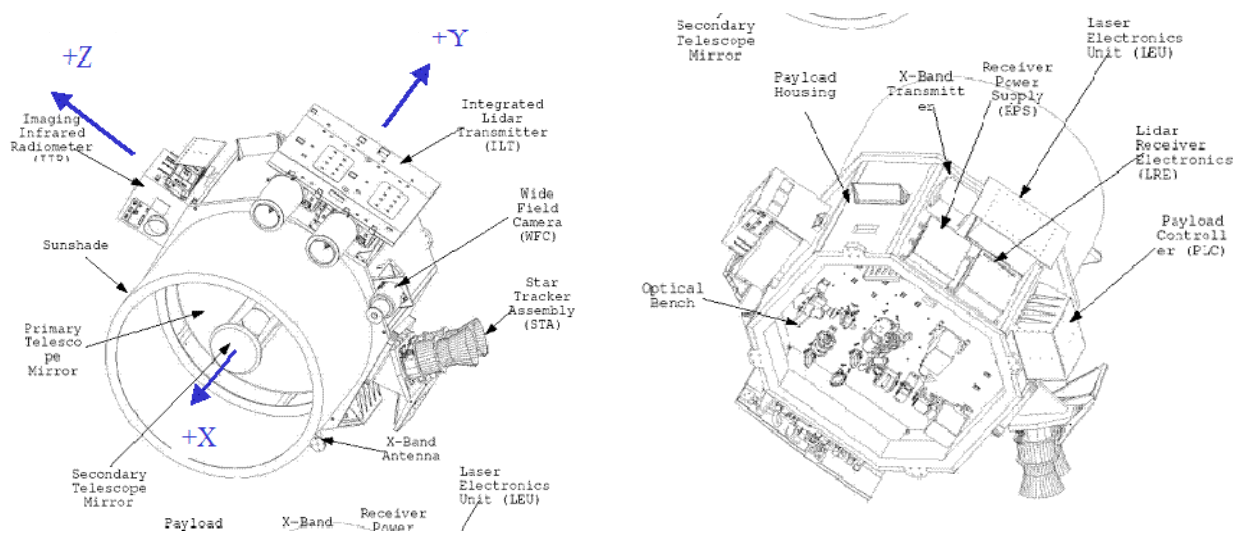

Figure 5: CALIPSO Payload Description

3.1 THERMAL SYSTEM DESCRIPTION

The CALIPSO payload thermal design is passive, with the exception of active heater controllers [3]. It employs Multi-Layer Insulation (MLI) blankets and selected surface finishes to achieve temperature control. Heat rejection is primarily from each electronics box-top radiator, the laser radiator, and two

radiators on the payload housing. The payload external configuration including the payload coordinate system is shown in Figure 5. The majority of the payload is blanketed with MLI. Exceptions include 5-mil Silver Teflon tape used as a radiator surface for the LEU, RPS, LRE, and the payload housing (two locations) and Z93 white paint used as a radiator surface for the PLC, WFC, and laser radiator. Z93 was used on these components due to their irregular surfaces which would make it difficult to tape with Silver Teflon. The Imaging Infrared Radiometer (IIR) and Star Tracker Assembly (STA) both have second-surface mirror (SSM) radiator surfaces.

The outer layer of payload MLI blankets is Dupont 275XC carbon-loaded black Kapton on all sides except the -Y side. Optical properties of Black Kapton do not degrade over the mission which aids in payload temperature stability. Structural/Thermal/Optical distortion is of major concern in meeting payload science requirements. The -Y side of the payload has the most solar exposure and a 5-mil Silver Teflon MLI outer layer was installed to reduce heat transfer into the payload. NASA LaRC and GSFC recommended and carried out this design enhancement to increase temperature margin. The IIR instrument and STA have a Kapton outer layer.

Payload operational heaters are controlled internally by the PLC. Survival heaters are controlled by the PROTEUS platform which provides an allocation of 11 primary and 11 redundant heater lines (not including the STA). The CALIPSO payload uses all 11 heater lines. PROTEUS survival heater lines use a defined PI control algorithm dictated by the platform which requires that the payload provide two coefficients (C1 & C2) and a target temperature T_t .

3.2 ANALYSIS AND TESTING

The payload is conductively isolated from the platform by four titanium interface pods with a conductance of 0.04 W/K each. Radiative isolation is achieved by an MLI blanket on the top of the platform, which covers the bottom of the payload optical cavity. In addition to conductive and radiative couplings, the payload thermal model also includes representations of the platform SSM radiator surfaces and rotating solar arrays. Accurate modeling of the solar array is particularly important as it rotates directly in front of the laser radiator (+Y side) and all major electronic boxes (-Y side). A thermal model of the IIR was delivered in April 2001 and integrated into the payload model shortly thereafter. BATC developed a simplified STA thermal model to increase accuracy of payload thermal predictions, particularly with respect to blockages of the payload housing radiators. The final integrated Payload thermal model was done using Cullimore and Ring Software's Thermal Desktop and SINDA/Fluint programs. The geometric radiative model can be seen below in Figure 6. This model was used for all correlations and predictions from September 2004 to present.

Thermal testing of the payload was done in two stages. The payload-only thermal balance and vacuum test occurred at Ball Aerospace in Boulder, CO in December 2003. The results of this test provided for the majority of the correlation of the thermal model. There were also changes made to the laser radiator and other hardware as a result of this test. In August 2004, the payload was integrated to the platform and a combined satellite-level thermal test was performed (as stated above). Successful thermal balance test results were achieved, which satisfied the most critical test goal [4]. All instrument temperatures measured during thermal balance tests were within allowable temperature limits. Safe hold mode (SHM) operations test data also demonstrated that temperatures were controlled above minimum safe-hold temperature limits. In addition, pre-test survival heater power predictions were shown to be within 5% of measured values and approximately 10% below the SHM heater power limit (140W). However, there were several issues with the thermal control hardware of the payload which required additional hardware changes and further analysis. The largest of these issues, the laser radiator sizing and heater control scheme, is detailed below.

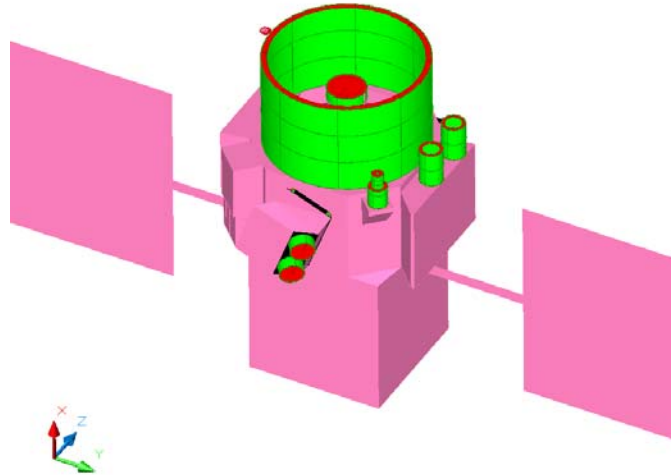

Figure 6: Integrated CALIPSO Geometric Model

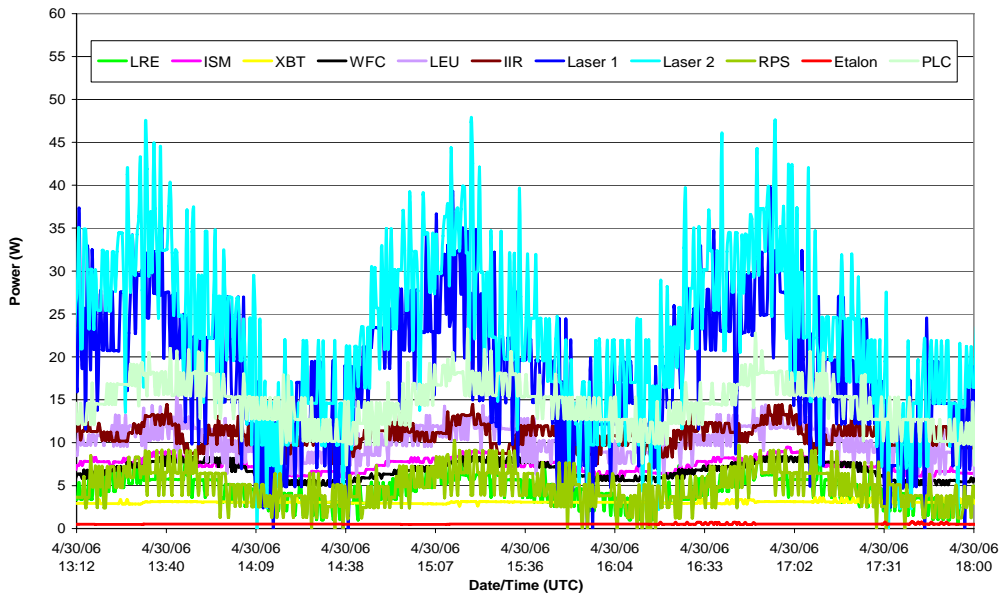

Figure 7 - SHM PL Survival Heater Power, Individual Lines

3.3 ON-ORBIT PERFORMANCE

Shortly after launch, the payload thermal team performed an evaluation of pre-launch predictions of performance for many subsystems. The platform-controlled Active Thermal Control (CTA) subsystem for the payload was of particular interest shortly after launch because it was instrumental in keeping the payload safe while the platform was being activated. After the platform activation was complete, the payload subsystems were activated one by one, with the last subsystem to be activated, the Integrated Lidar Transmitter (ILT), being heavily dependent on the thermal subsystem to allow it to operate properly.

Both during SHM and data acquisition mode (DAQ), the CALIPSO Satellite and the payload in particular performed well within defined thermal boundary conditions with appropriate margin. In PL

Standby Ready, Standby Thermal-Stabilization, and Safe modes, the PL thermal system performed well and was again within allotted power budget. After stabilizing in SHM, the payload's survival heaters were able to maintain the correct temperature set points and do so within the bounding amount of survival heater power allotted by the platform. Figure 7 shows the stabilized transient power consumption for each PL survival heater.

4.0 LASER HEATER CONTROL SCHEME

One primary objective of the satellite-level thermal vacuum test was to demonstrate positive thermal control of all payload components within their required temperature limits under simulated hot and cold flight environments while operating the payload in a flight configuration. While this major objective was essentially achieved, there was one very important exception: the results of this test showed sizing of the ILT radiator to be too large, because power dissipation within the lasers was lower than expected. At the original laser radiator size, the operational heater (at 20.7 W) used to maintain the operating laser's pedestal temperature at the desired 17°C set point would be undersized. Based on this result, a resizing of the ILT radiator was explored through analysis (integrated geometric analysis model shown in Figure 6).

After this parametric resizing analysis concluded the optimum area reduction on the ILT radiator was 21.5%, the thermal team pursued the idea of using the PROTEUS-controlled survival heaters to aid the pedestal heater. A concept was brought forth which took advantage of the non-operating laser's survival heater. Since both lasers are tied to the same radiator and are therefore conductively tied to one another, it would be possible to utilize the non-operating laser's survival heater to warm the whole ILT assembly and augment the operating laser's pedestal heater. Reliability of the survival heaters was deemed a non-issue for this system as each survival heater is redundant and has an expected lifetime greater than the mission duration [5]. Discussions between NASA and CNES engineers produced a workable survival heater control scheme, and initial control parameters were developed and tested prior to launch by the NASA/CNES/Alcatel spacecraft team. The laser thermal control system has performed flawlessly on orbit.

5.0 CONCLUSIONS

The CALIPSO satellite has continued to perform well throughout this first year of its science phase showing no serious thermal issues. As this paper has attempted to illustrate, one of the most important factors in the success of this mission has been the high degree of cooperation among all parties responsible for the various thermal control aspects of CALIPSO. Nowhere was this cooperative nature more evident than in the development of a solution to the potentially mission-ending laser radiator issue.

6.0 REFERENCES

- [1] F. Douillet and P. Landiech, *Overview of PROTEUS SmallSat Family*, IAC-02-U.4.05
- [2] M. Valentini and P. Arfi, *PROTEUS Small Sat Family: Multi-Mission Thermal Control Design and Performances*, 06ICES-329
- [3] J. Thomas, *CALIPSO Thermal Design and Analysis Report*, CALIPSO Systems Engineering Report SER-SYS-2481A (2003)
- [4] L. Fantano and W. Ousley, *CALIPSO Payload Satellite Thermal Balance Test Report*, CALIPSO Procedure Document, PC-SAT-673 (2005)
- [5] Gasbarre, J.F., *ILT Radiator Resizing Parametric Analysis*, CALIPSO Systems Engineering Report PCSER-JFG-004B (2005)