

Modular, Reconfigurable, High-Energy Technology Development

Connie Carrington
EV21
NASA Marshall Space Flight Center
Huntsville, AL 35812
256-544-0870
connie.carrington@nasa.gov

Joe Howell
VP33
NASA Marshall Space Flight Center
Huntsville, AL 35812
256-961-7566
joe.howell@nasa.gov

Abstract— The Modular, Reconfigurable High-Energy (MRHE) Technology Demonstrator project was to have been a series of ground-based demonstrations to mature critical technologies needed for in-space assembly of a high-power high-voltage modular spacecraft in low Earth orbit, enabling the development of future modular solar-powered exploration cargo-transport vehicles and infrastructure.^{1 2} MRHE was a project in the High Energy Space Systems (HESS) Program, within NASA's Exploration Systems Research and Technology (ESR&T) Program. NASA participants included Marshall Space Flight Center (MSFC), the Jet Propulsion Laboratory (JPL), and Glenn Research Center (GRC). Contractor participants were the Boeing Phantom Works in Huntsville, AL, Lockheed Martin Advanced Technology Center in Palo Alto, CA, ENTECH, Inc. in Keller, TX, and the University of AL Huntsville (UAH).

MRHE's technical objectives were to mature: (a) lightweight, efficient, high-voltage, radiation-resistant solar power generation (SPG) technologies; (b) innovative, lightweight, efficient thermal management systems; (c) efficient, 100kW-class, high-voltage power delivery systems from an SPG to an electric thruster system; (d) autonomous rendezvous and docking technology for in-space assembly of modular, reconfigurable spacecraft; (e) robotic assembly of modular space systems; and (f) modular, reconfigurable distributed avionics technologies.

Maturation of these technologies was to be implemented through a series of increasingly-inclusive laboratory demonstrations that would have integrated and demonstrated two systems-of-systems: (a) the autonomous rendezvous and docking of modular spacecraft with deployable structures, robotic assembly, reconfiguration both during assembly and in the event of module failure, and the use of reconfigurable distributed avionics systems to perform these functions; and

(b) the development and integration of an advanced thermal heat pipe and a high-voltage power delivery system with a representative lightweight high-voltage SPG array. In addition, an integrated simulation testbed would have been developed containing software models representing the technologies being matured in the laboratory demos. The testbed would have also included models for non-MRHE-developed subsystems such as electric propulsion, so that end-to-end performance could have been assessed.

This paper presents an overview of the MRHE Phase I activities at MSFC and its contractor partners. One of the major Phase I accomplishments is the assembly demonstration in the Lockheed Martin Advanced Technology Center (LMATC) Robot-Satellite facility, in which three robot-satellites successfully demonstrated rendezvous & docking, self-assembly, reconfiguration, adaptable GN&C, deployment, and interfaces between modules. Phase I technology maturation results from ENTECH include material recommendations for radiation-hardened Stretched Lens Array (SLA) concentrator lenses, and a design concept and test results for a hi-voltage PV receiver. UAH's accomplishments include Supertube heat-pipe test results, which support estimates of thermal conductivities at 30,000 times that of an equivalent silver rod. MSFC performed systems trades and developed a preliminary concept design for a 100kW-class modular reconfigurable solar electric propulsion transport vehicle, and Boeing Phantom Works in Huntsville performed assembly and rendezvous and docking trades. A concept animation video was produced by SAIC, which showed rendezvous and docking and SLA-square-rigger deployment in LEO.

TABLE OF CONTENTS

1. INTRODUCTION	2
2. CONCEPT DEFINITION STUDY	3
3. THERMAL MANAGEMENT TECHNOLOGY	9

¹ U.S. Government work not protected by U.S. copyright.

² IEEEAC paper #1118, Version 1, October 20, 2006.

4. ELECTRICAL POWER SYSTEM AND SOLAR CONCENTRATOR TECHNOLOGY.....	12
5. ASSEMBLY DEMO AND TECHNOLOGIES.....	13
6. MRHE ACCOMPLISHMENTS AND SUMMARY.....	17
7. ACKNOWLEDGEMENTS.....	17
REFERENCES.....	18
BIOGRAPHY.....	18

1. INTRODUCTION

Modular, reconfigurable spacecraft, assembled in orbit from identical building-block components, was a fundamental capability identified in NASA's 2004 Vision for Space Exploration. Goals included cost savings through multiple-unit production, module replacement, and module redundancy. Modular, high-energy, solar-powered spacecraft present particular challenges in assembly, power distribution, thermal management, and survivability in radiation environments. These technology issues were to be addressed in the four-year Modular, Reconfigurable, High-Energy (MRHE) Technology Demonstration project. MRHE, along with most of the other technology development projects selected in 2005, was closed out at the end of Phase I.

The MRHE Technology Demonstrator Project had planned to conduct system-of-systems laboratory demonstrations that would have supported technology development for modular solar electric transport vehicles, similar to the concept in Figure 1 [1]. The MRHE spacecraft concept consists of identical solar-powered modules, each equipped with an electric propulsion system, assembled in a reconfigurable arrangement. The concept also provides payload attachments on each bus that supports flexibility and configurability, accommodating multiple technology experiments that represent different exploration payloads.

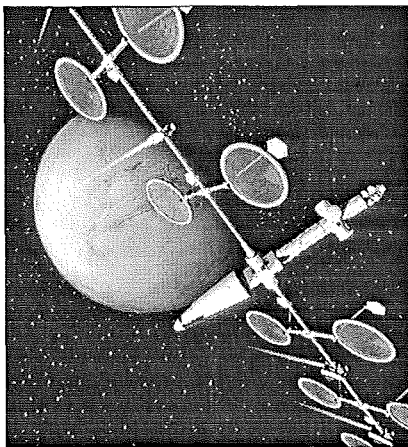

Fig. 1 Solar Clipper Transport Concept

The primary objectives of MRHE were to mature technologies for future development of a modular, 100

kilowatt-class spacecraft suitable for on-orbit assembly and reconfiguration. Maturation of ENTECH's Stretched Lens Array (SLA) solar concentrator technology included the design, development, fabrication, and testing of radiation-resistant concentrator lenses and photovoltaic receiver circuits capable of long-term operation at 1kV levels. The University of AL Huntsville (UAH) was to determine feasibility and then mature the "Supertube" solid-state heat pipe from Technology Readiness Level (TRL) 2.5 to TRL 5 by fabrication, testing, and analysis, and to develop and test an advanced radiator concept. The Jet Propulsion Laboratory (JPL) technology development responsibilities included a Power Delivery System (PDS), capable of handling 300 to 600 volts, and development of a distributed, fault-tolerant, wireless avionics system, for inter- and intra-module command and data communications, capable of performance equivalent to a 1394 bus [2]. JPL technology responsibilities also included the assembly of hardware models for the PDS, the avionics subsystem and the robotic assembly subsystem to support the MRHE demonstrations, from component to system levels. Glenn Research Center's responsibilities included maturation of thin-film solar power generation technology by developing and evaluating thin film photovoltaic coatings to enable high voltage array operation, and evaluating thin film photovoltaic performance under low energy radiation conditions [3]. Autonomous rendezvous and docking (AR&D) responsibilities at MSFC included evaluation, simulation, and testing of target geometries, acquisition sensors, and proximity operations scenarios suitable for MRHE modules.

Project deliverables for the four-year activity included concept definition, system design, feasibility studies, architecture and operations concept development, and laboratory demonstrations of satellite self-assembly and reconfiguration, an evaluation of integrated components, and an assessment of system functionality for major critical systems. The project would have delivered a set of integrated laboratory demonstrations, including three reconfiguration and assembly demos using multiple robotic satellites in an assembly testbed laboratory facility at Lockheed Martin's Advanced Technology Center (LM ATC).

This paper provides an overview of the MRHE Phase I accomplishments of MSFC and its contractor partners, documented in the MSFC final report [4]. A summary is presented of MSFC's concept definition study, Boeing's AR&D and launch vehicle assessment [5], UAH's thermal management testing and technology development [6], ENTECH's SLA development and testing [7], and LM ATC's robotic assembly demonstration and technology developments [8].

2. CONCEPT DEFINITION STUDY

The objective of the Phase I concept definition study was to develop a concept and mission scenario that would provide top-level requirements and a focus for the technologies being matured in MRHE. Configuration trades and assembly concepts were to be developed in the first three months of Phase I, so that decisions on voltage levels, power-conduction across joints, and robotic berthing versus autonomous docking could be made. These decisions would influence early requirements development for the power delivery system, module interface design, and the robotic system. Preliminary requirements documents for selected subsystems were written in Phase I, to provide a blueprint for the hardware development and testing in Phase II.

Guidelines and Assumptions

Concept definition guidelines included identical spacecraft buses, each launched on a Delta 2-class launch vehicle and self-assembled in low Earth orbit (LEO). Each spacecraft bus was to be powered by solar energy, using Stretched Lens Array concentrators and body-mounted planar panels. The assembled configuration would have at least 100kWe total at end of life, with continuous high-power operational capability only during periods of insolation. Direct-drive of the electric thrusters was a principal objective, so a nominal voltage of 600V from the solar arrays to the thrusters was a guideline. A lifetime of 5 years was baselined. Each spacecraft bus would have an identical payload deck, capable of supporting 150 kgs of payload mass, and providing utilities. After assembly and check-out in LEO, each spacecraft in the configuration would use its solar electric propulsion system to transport the assembly to a higher orbit, through the Van Allen belts and beyond.

The JPL MRHE team performed payload trades and mission design studies, and are documented in the JPL MRHE final report [2]. The reference mission selected for study was a selection of science instruments transported from a 28.5 degree, 300km Earth orbit to lunar polar orbit. The two representative science payloads, to be mounted on two of the spacecraft buses, were a topographic LIDAR altimeter for detailed 3D surface mapping of the lunar surface, and a chemical LIDAR tuned to detect evidence of water ice and other resources suitable for in-situ utilization. Representative payloads for the other spacecraft buses were to have been selected in Phase II.

Configuration Trades

MRHE proposed the investigation of a new tetrahedral configuration concept for modular spacecraft, and a comparison of that configuration with the solar clipper linear modular configuration conceived in the Space Solar Power (SSP) studies. The tetrahedral configuration consisted of four identical solar-powered buses, each equipped with an electric propulsion system, which self-assemble, either through docking or via robotic capture, into a stable,

tetrahedral truss configuration. Each bus was to have a reconfigurable payload deck that could accommodate a single large payload or multiple smaller payloads, depending on mission requirements. The tetrahedral configuration was conceived so that each satellite's solar array contributes 36 kW of power, providing 100kWe from only three buses, to compensate for shadowing of the fourth bus. A PMAD system integrated into the tetrahedral truss would route power to the payload or shadowed bus, as needed.

After initiation of the MRHE project, a feasibility investigation of the tetrahedral configuration was begun. Preliminary orbital analysis of the configuration showed that significant shadowing of the solar arrays on at least two of the modules occurs for long periods during the spiral out of LEO. Oversizing the arrays or increasing the lengths of the tetrahedral truss members does not adequately address this shadowing issue. In addition, this configuration requires the routing of power through the tetrahedral truss to the electric thrusters on shadowed buses. The power management system in this configuration would be complex and dynamic as the spacecraft attitude and orbits change. The routing of power through the truss also requires high levels of power transfer across yet-to-be-designed, multi-degree-of-freedom rotational joints at each of the spacecraft buses. Hence the tetrahedral configuration for the MRHE modular concept was eliminated early in the concept definition study.

The solar clipper linear configuration, shown in Figure 1, was a modular concept proposed during the Space Solar Power (SSP) studies. Propulsion modules are separated from solar power generation modules by booms, and a single large payload is located at the center of the configuration. Orientation options during the spiral out from LEO include: (1) Sun-oriented inertially fixed orientation, with the long axis of the vehicle perpendicular to the sun, (2) Perpendicular-to-the-orbit-plane (POP) orientation, with the long axis of the vehicle perpendicular to nadir and aligned with the orbit normal, and (3) Gravity-gradient orientation, with the long axis of the vehicle parallel to nadir. The sun-oriented inertially fixed orientation produces significantly large gravity-gradient torques on the vehicle while in Earth orbit, requiring large control authority to maintain this orientation. The POP orientation, which the SSP solar clipper proposed, allows the arrays to face the sun while the thrusters rotate about the long axis to maintain velocity-vector orientation, but separate modules are needed for the solar arrays and thrusters, with sufficient separation between these modules to avoid plume impingement. The gravity-gradient orientation has significant shadowing of the arrays around noon and midnight, which could be reduced by increasing the separation between modules. The gravity-gradient orientation has the significant advantage of mounting the solar arrays and thrusters on the same module, much like current spacecraft are designed.

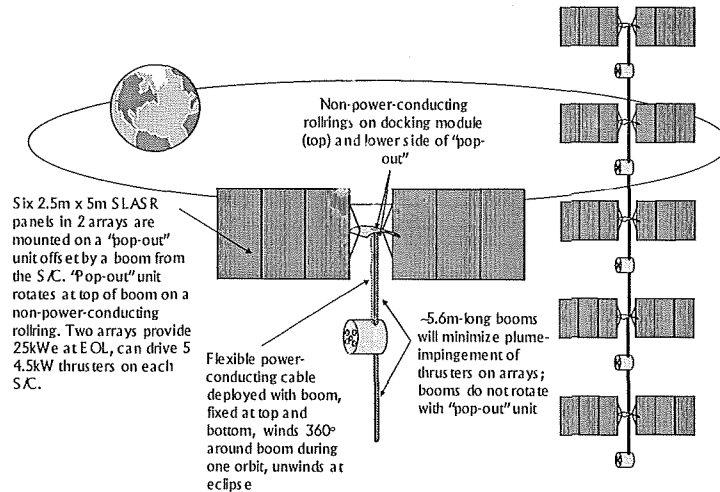

Fig. 2 Perpendicular-to-Orbit-Plane (POP) Orientation

For simplicity of design, the configuration team initially selected the gravity-gradient orientation for study, but found that in near-Earth orbits at 28.5-degree inclinations, shadowing of one satellite by the next satellite was significant, even for boom lengths in the range of 15-20m. Shadowing requires periodic shutdown of thrusters on the shadowed spacecraft, which complicates thrust vector control and produces libration of the configuration around nadir. Hence the gravity-gradient orientation was rejected, and a perpendicular-to-orbit-plane (POP) orientation that removes the shadowing issues between spacecraft was chosen. This orientation produces a more complex spacecraft configuration, in which the solar arrays are located on a separate unit, deployed by a boom from the spacecraft bus. The deployable unit will rotate about this boom to track the sun, as the spacecraft bus keeps the thrusters aligned nominally along the negative-velocity direction. The POP configuration is shown in Figure 2.

The boom length in the "pop-out" configuration shown in Figure 2 was initially selected to avoid plume impingement on the solar array panels. JPL performed a quick analysis which showed that plume impingement on the solar arrays primarily erodes the SLASR framework. Hence the requirement for complete plume avoidance, which initially was used to determine boom lengths, was reduced, and a boom length of ~5.6m was selected.

Spacecraft Bus Preliminary Design

The primary design drivers for the spacecraft bus and packaging are the Delta 2 launch vehicle, the POP configuration with solar arrays on the same side of the spacecraft, the SLASR solar arrays, which deploys in two directions and has a relatively-fixed aspect ratio, the boom deployers, which require spacecraft volume for the canisters and a transition structure, and the propulsion system needed

for module assembly in LEO. The Delta 2 two-stage launch vehicle can deliver 2.7 to 6 metric tons of payload to LEO. The 3.0m composite payload fairing and 6915 payload attach fitting were used to size the spacecraft bus.

JPL reviewed Hall thruster options compiled for the JIMO EP study and selected Aerojet's BPT-4000 thrusters for MRHE. These thrusters require 4.5 kW and provide 0.26N of thrust and an I_{sp} of 2059 seconds at 400VDC. A summary of the JPL propulsion system trades can be found in the JPL MRHE final report [2]. MRHE baselined five of these thrusters on each spacecraft bus, mounted on a gimbal plate. JPL also sized the Xenon tank, using data from the Dawn mission.

LMATC, who was responsible for the booms and a new deployer design for the assembly demo, provided the boom concept. The concept definition study had to be completed in the first six months of MRHE, so it did not include the LMATC deployer design, which was developed later in Phase I. The volume reserved in the concept configuration for the boom deployer was capable of housing a 33m long boom, significantly longer than the final boom length of 5.6m.

The SLA solar arrays were sized using data from the 2004 Boeing preliminary design study for a 100kW High-Power Technology Demonstration Spacecraft [9]. Using a 3-month transition period through the Van Allen belts, and extrapolating quadruple-junction cell efficiencies to 2008, the waterfall chart of conversion efficiencies from the Boeing study provided an EOL 342 W/m² areal power density. For 25kWe at EOL, the arrays were sized for each spacecraft bus at 75m², using six 2.5m x 5m standard-bay panels in a SLA Square Rigger frame.

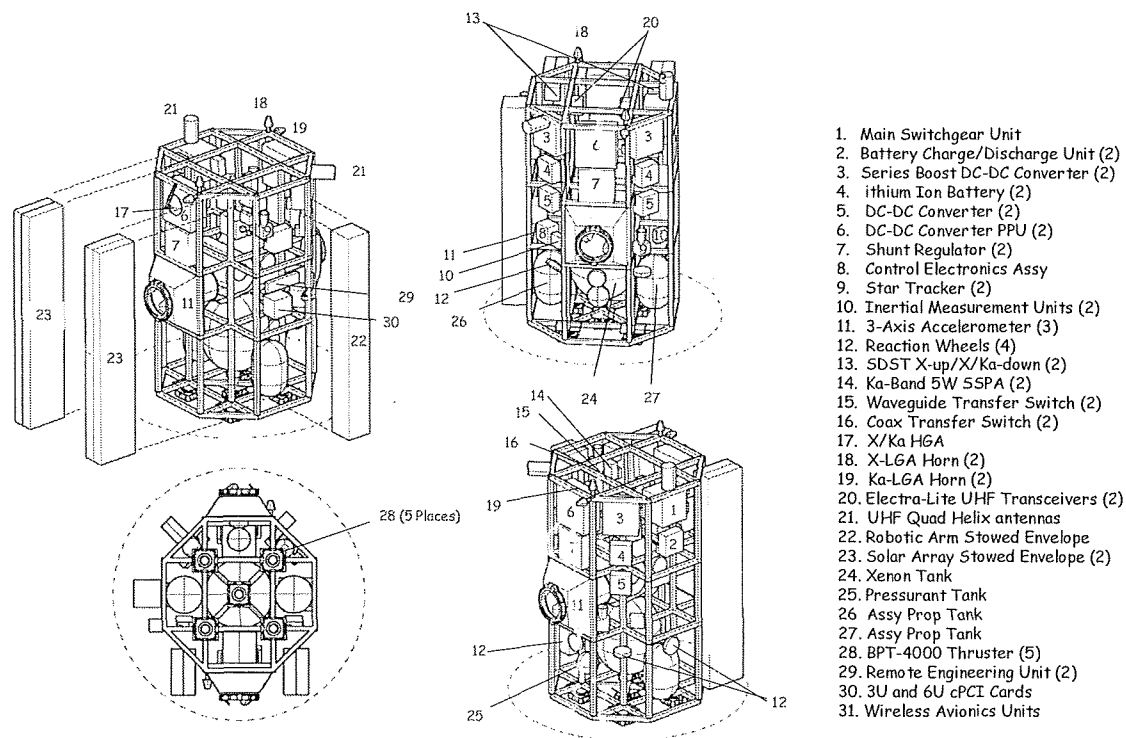

Fig. 3 Major components in the bus concept

The bus structure was designed with an octagonal cross-section, which lends itself to the four-hardpoint Delta 2 6915 payload-attach fitting (PAF). Longeron-frame-panel construction was used for the primary structure in three vertical bays of the bus. Interior longerons are 2x2x0.083 inch square aluminum tubing, and exterior longerons are 2x2x0.125 inch square aluminum tubing. The total vertical length of the bus is 3.21m without the payload instrument and 1.70m across the flats. This is an asymmetrical layout, with solar arrays on one side, and the payload manipulator arm on another side. The spacecraft platform provides major services for the satellite bus and payload operation. These include power, command and data handling, telecommunications, attitude and orbit control, thermal control, spacecraft rendezvous and docking, and payload change-out and reconfiguration. Major MRHE components are shown in Figure 3.

Boeing developed trades for delivering the MRHE satellites from the Delta II launch vehicle to the 300km altitude orbit for assembly. An early baseline concept was to insert the MRHE satellite into a 180-185km orbit from a basic two-stage Delta II vehicle, and then use self-propulsion to raise the altitude to 300km. The satellites would also perform orbit phasing at 300km to rendezvous with other MRHE satellites for assembly. Initial assembly propulsion options were: (1) the use of an auxiliary chemical propulsion system on each spacecraft, (2) a hybrid system on each spacecraft, consisting of a disposable solar array to provide power for one electric thruster, and (3) a chemical propulsion service and assembly module (SAM), which would ferry MRHE

satellites and perform rendezvous and docking with the assembled cluster. These trades recommended an upgraded GEM-augmented Delta II vehicle, which placed the satellites directly into the desired 300km orbit.

A mono-propellant system was added to the MRHE satellites for orbit phasing and rendezvous, in addition to a cold-gas system for docking. The assembly propulsion subsystem recommended by Boeing was a main hydrazine monopropellant system with six thrusters rated at 25 lb_f each and twelve thrusters rated at 1 lb_f each. A secondary cold gas system with twelve thrusters rated at 1 lb_f each would provide proximity operations and docking capability. Tanks were sized for each of these systems and added to the MRHE satellite configuration, mounted adjacent to the central Xenon tank. Based on Boeing's Orbital Express (OE) analysis experience for a typical rendezvous scenario, the required delta-V is 90 fps, with 10 fps is added for attitude maneuvers, for a total = 100 fps. Initially, a 100% design margin was used to account for dispersions, two possible wave-offs, and leave margin, providing a design prop budget at 200 fps to get the vehicle to a close proximity operations point. The GN&C errors were estimated using Boeing's OE analysis experience for rendezvous scenarios. Details of the assembly propellant systems, and rendezvous approach trades are documented in the Boeing final report [5].

Another configuration driver was the two boom-deployer systems needed for each MRHE satellite, shown in Figure 4. The booms are collapsible rollable tubes developed by

ATK under contract to Lockheed Martin ATC, and require a supported transition region from where it exits off the spool to a distance where the boom is fully unflattened and capable of supporting loads. The boom on the spacecraft concept was 13.75 inches in diameter. A concept for the transition-region support structure, based on telescoping tubes, is shown in Figure 4. This figure also shows a preliminary design for the drive mechanism to rotate the solar array assembly around the boom.

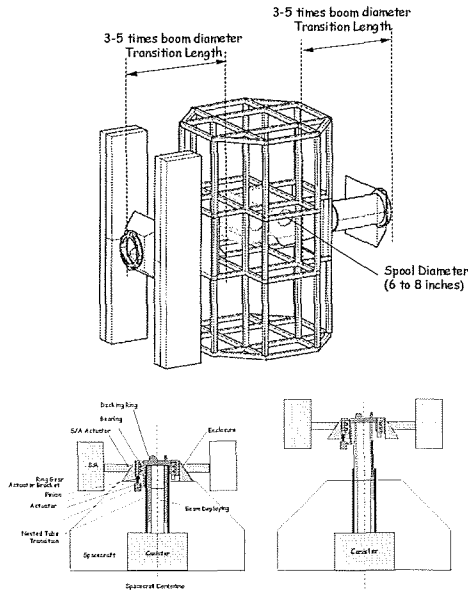

Fig. 4 Dual Boom Configuration and Transition Support-Structure Concept

To bring power from the SLA arrays to the spacecraft bus, study options included embedding the cables in the boom or running an insulated high-voltage power cable along the outside of the boom. As a worst case, 35kWe power transfer from the arrays to the bus was examined. For 600V, the required power cables would be 6 AWG for about 60 amps, or, for 1000V, 8 AWG for about 35 amps. The 6 AWG wire has a circular cross section with a diameter of 0.24 inches, which is a fairly large wire. Two options for embedding wire in the boom structure were examined: using multiple smaller gauge wires, or using ribbon-like wires with rectangular cross-sections. Both of these options require technology development, and since the rollable boom was a technology development in itself, the embedded-wire option was not selected for the spacecraft concept. The 600V power cable would be rolled on a spool mounted outside the boom-deployer, and as the boom is deployed, the cable would unroll, parallel to the boom.

Since the BPT-4000 electric thrusters nominally run at 400V or lower voltages, but could be qualified to run at 600V, trades were done on thruster voltages. MRHE proposed a 600V power backbone and arrays at 600V in the project proposal for technology development and maturation, to provide a roadmap for 600V systems required by large Hall

thruster exploration systems. However, converters at the PPU's could be used to lower voltages from the backbone, if lower voltage thrusters were advantageous to the MRHE transportation system. JPL analyzed lower voltage options in their trajectory analysis from LEO to lunar orbits, and found that shorter transit times occurred for the lower voltages, a desirable feature when transiting the Van Allen belts. However, at 600V, the propellant savings were significant, even though the transit times were somewhat longer, so direct-drive from the arrays at 600V was recommended for MRHE. All electronics will be shielded for radiation exposure during the longer transit times.

Mass estimates for each MRHE satellite are shown in Table 1; these are launched mass estimates, including phasing and assembly propellant. Battery and wiring masses were scaled from previous studies, and the payload arm robotic unit was based on a mass estimate for only payload reconfiguration and not berthing-assistance during assembly. Estimated masses also include the split power system between the solar array assembly and the spacecraft bus, the parallel lower and higher voltage power backbones, the rotating mechanisms between the booms and the solar array assembly, and the docking mechanisms. With a payload allowance of 150kg and an estimated 700kg of Xenon for transit from LEO to lunar orbit, the launched mass of each MRHE satellite is estimated at 2500kg. Details of the concept definition study and operational concepts can be found in the MSFC final report [4].

Table 1. Launched Mass Estimates for One Satellite

Subsystem	Mass (kg)
2 Solar Arrays + Mechanisms	125
Computing & Data Handling	57
Telecommunications	27
Attitude Control System	40
Electric Propulsion System	180
Monoprop. Assembly Propulsion System	137
Electrical Power System	210
Batteries	75
Wiring	35
Automated Rendezvous & Assembly Sys.	40
Structures & Thermal	285
Rotating & Docking Mechanisms	70
2 Booms & Deployers/Structure	60
Robotic Unit	25
Margin/Contingency	273
S/C Dry Mass (with contingency)	1640
Payload	150
Propellant	700
Total	2490

Concept of Operations

JPL and MSFC jointly developed a concept of operations for the MRHE mission, with MSFC providing launch and assembly operations, and JPL providing transit and lunar mission operations.

Five identical satellites, each approximately 2500 kg, will self assemble in LEO into a gravity-gradient-oriented configuration, separated by deployable booms. Each satellite has a "pop-out" unit that supports the solar arrays at a suitable distance from the spacecraft body to minimize electric thruster plume impingement. After assembly, the configuration will reorient to a perpendicular-to-orbit-plane (POP) configuration, so that each module's solar arrays will be illuminated. Each satellite will fire its five solar electric Hall thrusters to spiral out to the moon, where the modular configuration will separate into individual satellites. The payloads on each of the satellites will then gather data in lunar orbit and transmit it to earth.

Each MRHE spacecraft is launched on a two-stage Delta 2 from the Cape into a 300 km circular orbit at 28.5-degree inclination. At the current mass estimates, a Delta 2 model 7420 with four GEMs and a 3.0m fairing is suitable. The Delta launch operations center at the Cape is planned for use in vehicle integration, launch support, and immediate on-orbit support. A yet-to-be-determined ground operations center will monitor and control assembly in LEO, transit to the moon, and lunar operations.

The Delta 2 second stage will insert the spacecraft into a 300 km circular orbit. Power during this phase of the mission will be provided to the spacecraft by batteries and body-mounted solar panels. The spacecraft will acquire the sun using sun sensors and use its chemical assembly propulsion system to stabilize attitude, and then use its star trackers to orient itself so that the solar-array pop-out unit points in the nadir direction, and the electric thrusters point in the negative-velocity direction.

The assembly propulsion system on each spacecraft provides translational and full three-axis control for in-orbit phasing, rendezvous and docking, and momentum management. The main system is a hydrazine monopropellant system, and a secondary cold gas system provides additional propulsion capability for close proximity operations and docking.

A representative deployment scenario for the first spacecraft is shown in Figure 5. After the attitude control system orients the spacecraft with the solar-array unit in the nadir direction, the boom transition structure deploys for the solar array boom system. The boom transition structure provides the transitional support between the flat-rolled boom on its reel and the fully deployed circular cross-section of the boom. The boom can be deployed to an intermediate distance of 3m, which will provide a shorter configuration length during assembly, if required for control management

during the build phase. As the boom deploys, an insulated high-voltage power cable is unrolled, parallel to the boom between the spacecraft body and the solar array unit. The Stretched Lens Array in its Square Rigger (SLASR) frame deploys; the frame is first unfolded and locked in place, and then motors draw the folded SLAs across the bays. The arches supporting the stretched lenses spring into position, and the unit is rotated into position to start tracking the sun by rotating the solar array unit around the boom tip. The arches may be shifted to effect beta-tracking by shortening the distance between the stretched lens and the solar cell strips. An optional process for beta-tracking is to use solar-array drive assemblies at the base of each solar array.

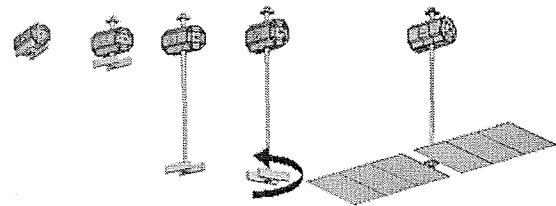

Fig. 5 Deployment Scenario for First Satellite

Subsequent modules will be launched on Delta 2 vehicles nominally into the same 300 km, 28.5-degree circular orbit of the first module. Dispersions from the Delta 2 second stage insertion could require as much as a 10 km altitude raise, and small corrections in inclination. Previous experience has shown that several dispersion sources will need to be accommodated by the GNC and propulsion systems. These dispersions result from inertial initialization and updates, inertial drift, and navigation system accuracies.

A reference trajectory and scenario for the phasing orbit and rendezvous, based on Boeing's Orbital Express experience, is shown in Figure 6. The reference trajectory includes options for various sensors in tracking the target module. The new module could begin far-range visual tracking of the target module at around 200 km. At approximately 28 km from the target module, the rendezvous module will begin the first of several in-plane Lambert trajectories to close in on the target. At approximately 20 km, infrared tracking of the target could begin, and at 10 km from the target, Advanced Video Guidance Sensor (AVGS) or lidar tracking could start, if needed. At 6 km, the rendezvous module goes into a hold position, in which GN&C updates, sensor information, and health monitoring of the propulsion system could be done, in addition to ground-operator monitoring, intervention, and permission-to-proceed for the next phase, if needed.

Figure 6 also shows a short-range view of the phasing orbit, beginning from the permission-to-proceed hold point at 6 km. The second Lambert trajectory will bring the rendezvous module to the 1 km hold point, in which GN&C

updates, check-out and permission-to-proceed could be done. The AVGS will provide attitude, range, and bearing from 120m into the target. A third Lambert trajectory will bring the rendezvous module from 1 km around the front of the target module to a third "hold" point at 120 m in front of the target vehicle. The last Lambert trajectory will bring the rendezvous module above, back, and then down to the negative-R-Bar approach to the target module. At close proximity operations, the secondary propulsion cold-gas system could be used, if contamination from the monoprop system is an issue. The phasing orbit, from 200 km to the last hold point, could take approximately 7 hours.

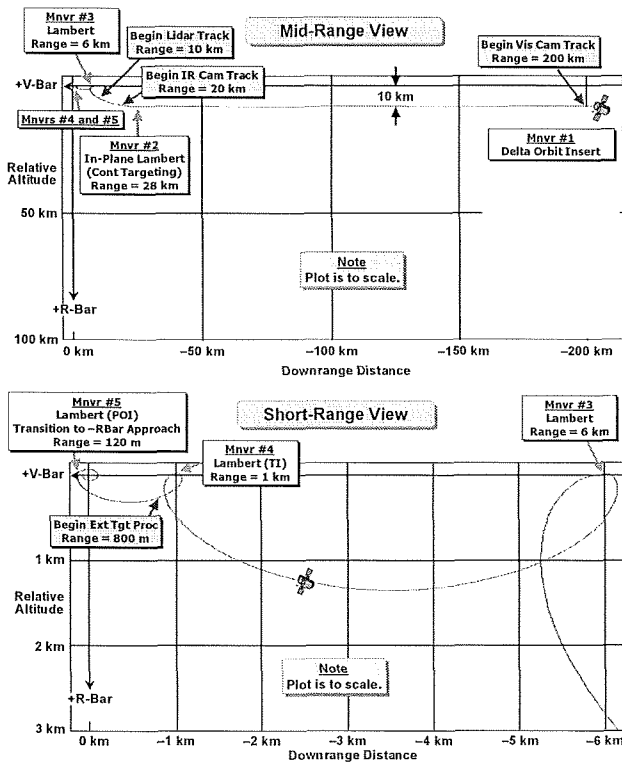

Fig. 6 Phasing Orbit and Rendezvous (Mid- and Short-Range)

After mating between the two modules, the transition structure will deploy from the new module to begin boom deployment for the solar array unit. The solar array unit boom is deployed to the intermediate 3m length, with the high-voltage power cable unreeled in parallel. The second boom on the first module, which separates it from the solar arrays on the second module, will deploy to the intermediate 3m length, and then the SLASRs to power the second module will deploy. No power connection runs from the second module to the first module.

New modules will follow the same process of orbit phasing, rendezvous and docking/berthing, and then boom deployment and solar array deployment. After the assembly is complete, the configuration will perform a 90-degree roll to align the booms along the orbit normal. The booms will

then deploy to their full length, and the system will begin preparation for spiral transport using the solar electric thrusters.

Once the final configuration has been attained and the POP orientation has been achieved, all five thrusters on each module will then be brought on line and the spacecraft will begin to spiral out from the 300 km orbit on a low-thrust trajectory. Preliminary low thrust trajectory analyses were developed by JPL for the MRHE spacecraft example mission [2]. There are two phases to the spacecraft's transit between the Earth and the Moon. The first is the ~5 month spiral out from low Earth orbit (LEO) that takes the spacecraft beyond the Van Allen radiation belts. The second phase is the ~5 month spiral into low lunar orbit (LLO). The total trip time for the example mission is approximately 10 months, during which ~3350 kg of propellant would be consumed by all five MRHE modules (670 kg/module). The five month spiral out from LEO through the Van Allen belts represents the largest single source of radiation for the spacecraft, corresponding to ~32 krads total ionizing dose (RDF=1) assuming nominal environment conditions. Once beyond the belts and while in lunar orbit, the spacecraft is expected to see approximately 5 krads per year. Thus, the total mission radiation dose is estimated to be ~54 krads. Spacecraft shielding was estimated at 100 mils of Aluminum, with additional shielding if required to maintain dosage levels acceptable to the avionics hardware. Once the vicinity of the Earth-Lunar L1 point has been achieved, the spacecraft will transition to a lunar polar orbit and spiral down to a 300 km lunar altitude.

The study identified two conditions under which payloads may be reconfigured once the initial lunar orbit is achieved: (1) Reseating of a payload onto another module if its hosting module is disabled in a fashion that would prevent operation of the payload as planned; and (2) Assembly of a larger payload using portions of the payload mounted on several spacecraft payload decks. In either of these events, the robotic assemblies would transfer the payload from the source module to the destination module in a cooperative fashion. The robotic assembly on the source module would grasp its payload, any payload latching mechanisms would be disengaged, and the robotic assembly would then move the payload to the midway point between the source and destination modules. The destination module robotic assembly would then grasp the payload. Once the destination robotic assembly has confirmed grasp of the payload, the source robotic assembly will disengage from the payload. The destination robotic assembly will then move the payload onto its payload deck and place it into position for securing its connections to the destination module. Once placement has been confirmed, latching mechanisms will be engaged to secure the payload on the destination module. This process may be entirely automated, or ground confirmation may be required to proceed from one step to the next.

Once the initial lunar orbit has been achieved (nominally 300 km polar orbit) and any payload reconfiguration required has been accomplished, the modules could disconnect from each other one at a time and use their monopropellant or cold gas system to achieve a safe separation distance. Each module would then achieve their respective lunar operations orbits by using either their electric propulsion system or the monopropellant system.

3. THERMAL MANAGEMENT TECHNOLOGY

High power satellites must provide equivalent thermal management capability. Phasing thrusters, altitude thrusters, remote manipulating arm, beam deployment, beam docking, and down link antennae, as well as of power conditioning, communications, and other electronic boxes must be thermally managed for the several configuration states, environments, and internal heat loads of the MRHE mission.

In low earth orbit, these configuration states include the battery powered, undeployed, single MRHE unit, the battery and solar powered build up of MRHE units into the cluster, and the fully deployed MRHE cluster of up to five units. In transfer orbits and lunar orbits, these include solar powered and cold gas thruster phasing of the fully deployed MRHE cluster. The high waste heat that must be dissipated due to the significant power levels on these spacecraft buses require a high heat dissipation technology. The technology selected was the patented "Supertube" by Dr. Yuzhi Qu, due to its extremely high thermal conductivity and its temperature operation regime. With successful maturation, Supertubes could be utilized to direct heat to and from an optimally placed Advanced Space Radiator (ASR) to effectively dissipate the waste heat from high-power users on the MRHE satellite.

Overview of Testing on Supertubes for an Advanced Space Radiator

Several Supertubes, both gravity independent and dependent, and in a variety of lengths and diameters, have been extensively tested by Dr. James B. Blackmon and graduate student Sean Entekin of the University of Alabama Huntsville (UAH) Propulsion Research Center [6], [10]. The goal of the testing was to determine if potential payloads, electric thrusters, or other high-power users on the MRHE bus could be cooled by radiation alone to temperatures of 100 C or less. Key to providing this amount of heat dissipation is high conductivities that direct heat away from the heat source, for radiation to a cooler environment. The Supertube superconductivity capability was investigated for use in MRHE. UAH's testing revealed an activation temperature for the superconductivity, and implied a possible minimum heat flux rate necessary to activate the superconductivity.

UAH's conductivity tests have repeatedly shown the thermal conductivity to be much greater than that of copper for a

comparable diameter tube and wall thickness. This increase is more than 10,000 times higher for the shorter lengths (17" and less) tested, and more than 30,000 times higher for the longer (10') units tested.

Testing has also indicated a consistent superconductor activation temperature of approximately 30°C for the shorter units, and approximately 40°C for the longer units. Below the activation temperature, the Supertube has the conductivity of the material it has been placed inside, which was regular copper for the Supertubes tested by UAH. Above the activation temperature, the superconductivity properties are immediately exhibited, lasting up to the melting point of the base material.

Loss of the Supertube vessel wall integrity causes loss of the super conductivity. If a breach occurs, the tube reverts to the conductivity of the base material, at least when exposed to air and humidity for several days. Additional testing is required to determine if immediate repair, or use and repair under vacuum, or other optimal repair improves the recoverability.

Set I Supertube testing, as well as earlier testing on a pool boiling heat pipe, demonstrated the ability to achieve the heat rejection rates needed for the candidate concentrating photovoltaic array. However, the Supertube was far lighter, had a much smaller diameter, and offered higher effective thermal conductivities than the heat pipe.

The lighter weight of the Supertubes, at less than 40% of that of traditional liquid heat pipes, would allow use of multiple tubes to provide redundancy in case of failure. Several concepts for mechanically joining Supertubes were considered. Future analysis and testing are required to further assess these joining concepts which could be utilized to alter superconducting pathways to bypass breached units.

Use of some the Supertubes suggested gravity dependency, confirmed by further research into Supertube attributes. Although the space application would dictate those without gravity dependency, the longer units were procured with this feature due to availability.

Further research into Supertubes has also discerned that units are available that are optimized for at least three temperature ranges, a feature that was unavailable at the time of ordering the longer units. Future procurements should select optimal range for use with temperatures of the targeted photovoltaic array on MRHE.

Set I Testing of Shorter Supertubes

Initial testing was conducted on several types of heat pipe and prototype space radiators applicable to the candidate photovoltaic system. Early evaluation indicated the capability of Supertubes in providing extremely high thermal conductivity. Set I testing included several

“shorter” Supertubes that ranged from 4” long to 17” long. Some were found to be gravity independent, and the rest were gravity-dependent units. Set I testing also included similar-sized deoxidized copper rods for comparison. Testing was conducted in ambient and vacuum conditions, and thermal instrumentation was limited to only two or three sensors per test. K-type thermocouples were utilized as available and compatible with vacuum chamber data processing, and heat guns, heated/boiling water, or a band heater were used as heat sources.

Set I tests were exploratory, and utilized existing Supertube hardware – some damaged and all of insufficient length to explicitly quantify the thermal conductivity. However, heat gun testing of a 4” long, 7/8” diameter Supertube showed evidence of high thermal conductivity. Several boiling water and band heater tests of the 9” to 17” long Supertubes showed evidence of excellent thermal conductivity with notable exceptions. Assessment of the exceptions led to understanding that, besides an activation temperature there may also be a power level threshold. Tests of damaged and ruptured units led to understanding that some crimping will not adversely affect the superconductivity; however if the wall integrity is compromised, the units will revert to the conductivity of the base metal.

The data for the early boiling water test on a 17” Supertube, in Figure 7, shows how the Supertube is able to draw heat along its length notably better than a regular copper rod.

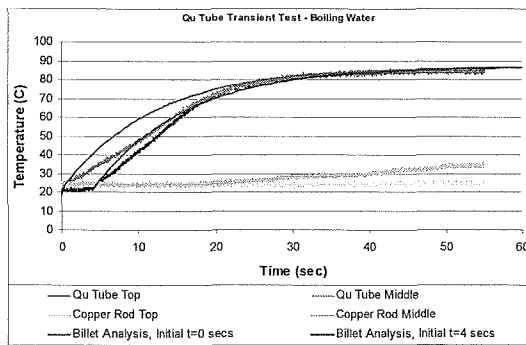

Fig. 7 Data and Billet Analysis for Boiling Water Test, 17” units

The billet analysis referred to in Figure 6 assumes an infinite thermal conductivity, and so is the ideal or best possible case. As shown, the Supertube performed almost equal to the assumed perfect conductor. And while it took less than 40 seconds for even the far end of the 17” Supertube to heat to approximately 88 C, the identically sized copper rod lagged considerably. In addition, these 60 seconds show the beginning of how temperatures on the copper rod will striate, whereas all of the Supertube has isothermalized. This isothermalization, and at temperatures higher than what

the base metal can achieve, are key to the higher heat rejection that Supertubes can provide.

Factors were then applied analytically to copper conductivity to determine lower bound of superconductivity seen in the Supertube. This factor was found to be a minimum of 10,000. Set I testing also discerned angle dependency in some of the Supertube units. As shown in Figure 8, the 7 7/8” L x 3/16” OD Supertube could be heated from either end and still display the Supertube effect when vertical and with either end up.

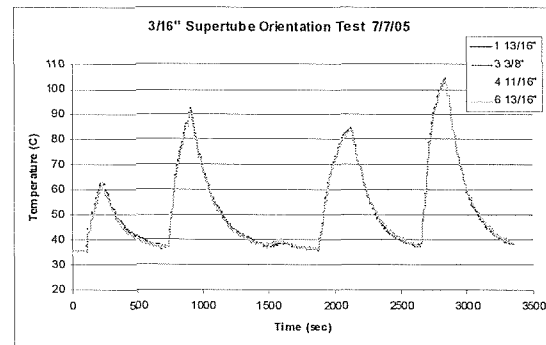

Fig. 8 Supertube with Gravity Independence

By contrast, Figure 9 shows the angle dependency of a 17” L x 5/16” OD Supertube. When held vertical, either end of the tube could be down, and if heated from below, the superconductivity would be activated. However, it could not be activated when heated from above.

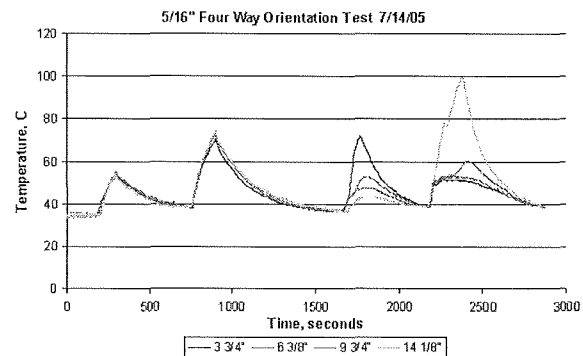

Fig. 9 Supertube with Gravity Dependency

Several of the shorter Supertubes were X-rayed, in part to help substantiate that there is no liquid in them. One of the X-rays is shown in Figure 10, and depicts the fine wire mesh found in the 17” and 4” long Supertubes. Renewed reviews of the Supertube literature and patents discerned language that there may be at least two versions: one with a mesh screen that is gravity independent and one with powders that are gravity dependent.

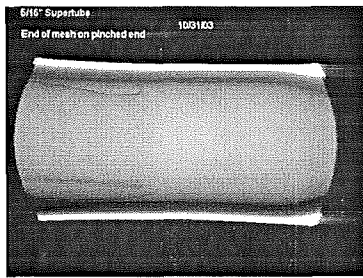

Fig. 10 Wire mesh in gravity independent Supertube

Set II Testing of Longer Supertubes

Set I testing indicated the need for longer Supertubes, more sensitive instrumentation, higher fidelity controllers, and joint and repair capabilities. Set II testing was conducted on 10 “longer” Supertubes, each 10’ L x 5/16” OD. These tubes were gravity dependent units, due to availability. Comparison was made with an identically sized deoxidized copper rod. Testing conducted to date on the 10’ units has all been in ambient. Thermal instrumentation currently limited to five sensors per test. K-type thermocouples are still being utilized, but will be replaced with thermistors as the “rake” is completed, and for tests where temperatures are on the order of 100 C. Band heaters were used as the heat source. Since these units were directionally dependent, they could not be tested in the vertical orientation without support. Instead, these units were tested suspended from the ceiling, at an approximately 30-degree angle, with the band heater at the lower end.

As the band heater was ramped up to 350 C, the 10’ Supertube performed as shown in Figure 11, where the Supertube at each of the five axial locations listed was essentially at the same temperature (isothermalized).

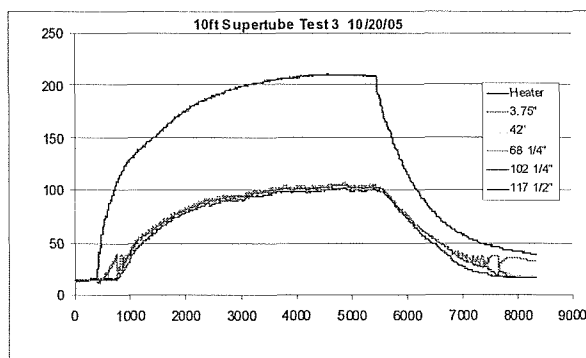

Fig. 11 Trend data from band heater test of 10’ Supertube

UAH inspection of the data found the superconductivity activation started at about 750 seconds and stopped at about 6500 seconds. This corresponded to about 40 C for calculated (not sensed) temperature of the 10’ Supertube under the band heater.

A test was then performed on an identically-sized copper rod. Again the band heater was ramped up, this time to approximately 275 C, the band heater temperature needed to get the copper rod sensor nearest it at about the same temperature it was in the 10’ Supertube band heater test.

The isothermalized response of the Supertube shows how they can be utilized to effectively conduct heat away from a high heat source. The gradient response of the copper rod shows it is ineffective for that function. Indeed, even the first section of the copper rod cannot conduct as much heat, and each section thereafter conducts even less.

Factors were then applied analytically to copper conductivity to determine a lower bound of the superconductivity seen in the Supertube. As shown in Figure 12, the factor is 30,000 as a minimum.

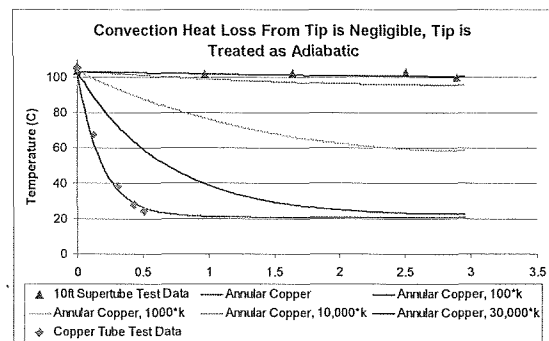

Fig. 12 Ten foot Supertube data and copper conductivity multiples

Connection Options for Supertubes to form an Advanced Space Radiator (ASR)

The high conductivity of Supertubes allows quick isothermalization of individual units. However, unless units can be joined by a process that would continue the superconductivity pathway, the ASR would have to be close to the high heat source. That location could have a less than optimal viewing environment and potentially high parasitic heat. In addition, thermally efficient joints would draw the heat more efficiently across the interface, helping conduct more heat to the ASR, where it can be efficiently radiated.

Connection options include joining tubes together with “snap-in” joints, using solder having a temperature above the maximum operational temperature. The solder would be “sweated” onto the tube’s inner joining surfaces and the outer surface of the connecting joint, such that when inserted into each other, and heat applied, the joints would seal. Another option is to join two sealed Supertubes together with an inner (or outer) slip joint sleeve, which can be soldered to the Supertube to form a better thermal path. This is essentially the same as joining two ordinary tubes, except that the slip joint sleeve would have the same

surface protective layer as stated in the patents, which in part protects the tube material from degradation.

A third connection option is to develop a connecting joint with an inner hollow needle that can pierce the ends of both Supertubes. As the tubes are inserted into the joint, a seal forms. As the tubes are inserted further, the needle pierces the Supertube ends. The gas that apparently forms in the Supertube, which may be the means by which the Supertube achieves high thermal conductivity, would then be able to pass between the tubes. The end of the Supertube may be formed from a plastic that allows the hollow needle to penetrate it, without plugging the needle. Alternatively, the end of the Supertube could be made of a relatively thin metal, or a metal plug with an inner hole plugged with a suitable material that would be pushed free by the hollow needle could be used.

Another option is to add a valve between each Supertube to the connection methods above. The valve would allow the gas in each tube to be in a continuous, open flow path, which may allow the Supertube effect to occur across the valve. In the event one of the Supertube sections was punctured, gas would escape to vacuum until the valves were closed. This could be accomplished with solenoid valve and a pressure sensor. After the valves have closed, the punctured Supertube could be removed and replaced.

A last option is to join sealed Supertubes using a relatively large joint area. However, these techniques would rely on conventional thermal conductivity across the joint from one Supertube to the next, necessitating a relatively large depth and contact area to reduce the temperature drop.

None of these joining concepts were tested during MRHE Phase I. Future work should include analysis and testing to further assess joint concepts, to conduct heat efficiently to an ASR, and to lower risk by creating alternate superconducting pathways to bypass any breached units.

4. ELECTRICAL POWER SYSTEM AND SOLAR CONCENTRATOR TECHNOLOGY

The key team members for the EPS were the Marshall Space Flight Center (MSFC), the Jet Propulsion Laboratory (JPL), the Glenn Research Center (GRC), and ENTECH, Inc. MSFC and JPL had overall MRHE roles in project management, project engineering, the development of specific systems, and integration and testing in laboratory demonstrations.

MSFC had responsibility for the overall coordination-management of the two solar power technologies with the power delivery system, plus the technology development and modeling of ENTECH's Stretched Lens Array (SLA) power generator.

JPL had responsibility for the requirements, design, demonstration, and modeling of the power delivery system. These responsibilities included (a) evaluating and implementing terrestrial power system techniques to the MRHE power delivery system; (b) evaluating and modeling a high-voltage (300-600 VDC) direct-drive power bus to the electric propulsion subsystem; (c) evaluating and designing a multiple power bus delivery system using International Space Station voltage levels (120 VDC); (d) establishing EPS power delivery requirements and technology needs coming out of the overall system concept definitions.

ENTECH's tasks included the design, development, fabrication and testing of both radiation-resistant concentrator lenses and photovoltaic receiver circuits capable of long-term operation at 600V to 1000V levels. ENTECH also provided system level inputs to the power delivery and thermal subsystems, and developed a system model of the SLA power generator.

GRC had responsibility for technology development of thin-film solar power generation subsystems and how these systems could best be utilized in an MRHE type system.

EPS Subsystem Description

The primary solar power generation system for each spacecraft consist of two arrays which provide a minimum of 25kW at the End of Life (EOL), and which drive five 4.5 kW electric thrusters and the general spacecraft load power. Each of the two arrays consist of three 2.5m x 5m stretched lens arrays developed by ENTECH, Inc. using a SquareRigger deployment system developed by Able Engineering, and called an SLASR array. The two arrays are connected to a rotating, non-power-conducting rolling, "pop-out" unit located at the end of the deployable boom. The power is transmitted at a high voltage (150 VDC to 600 VDC) down a flexible power-conducting cable deployed with the boom. This cable is fixed at the top and bottom of the boom and then winds around the boom during the solar tracking portion of the orbit. During eclipse, the cable unwinds back to its initial position to await the next sunrise.

At the spacecraft end of the power cable, the power is transmitted to the Power Delivery System (PDS) of the spacecraft. The PDS portion of the EPS was managed by the JPL. The electric thrusters are powered "directly" by the high voltage arrays, with a PDS architecture consisting of both high and low voltage busses. An auxiliary body-mounted secondary array powers the PDS from launch through primary solar array deployment, and the low voltage bus can be powered from this secondary array. A DC to DC down-converter is used to connect the high and low voltage busses. A Li-Ion secondary battery supplies power to the low voltage bus only, making high voltage bus operations impossible during eclipse. Electrical interconnectivity between spacecraft modules is not required.

ENTECH's Solar Concentrator Technology

The slow spiral out through the Van Allen belts has been estimated to take 5 months, requiring radiation-tolerant solar concentrator lenses and photovoltaic receivers. Over the past two decades, ENTECH and NASA have explored a wide range of possible lens materials for refractive concentrators, from fluoropolymers to clear polyimides to silicones to sol-gel glasses. Of all of these materials, space-qualified silicone (Dow Corning DC 93-500) has proven to be the most appropriate. ENTECH investigated the use of a new class of materials, known as Polyhedral Oligomeric Silsesquioxane (POSS), that could possibly offer even better radiation durability. ENTECH performed trade studies, analysis, and material tests on the new POSS materials. Based upon all of the results, the key conclusion was that the coated silicone lens material was still the preferred approach to concentrator lenses [7], [11].

ENTECH also began development for a durable, high-voltage, radiation-tolerant photovoltaic receiver. Their approach was to fully encapsulate the photovoltaic cell circuit with dielectric materials, to prevent direct environmental interaction with either the space plasma or the "grounded" radiator sheet material. The voltage gradient was also limited through the dielectric layers above and below the solar cell circuit to preclude long-term voltage-endurance (corona) failures of these insulating layers. Single-cell samples were fabricated and tested in underwater hi-pot tests. In these tests, the cell voltage is biased to very high levels (2,250 V_{DC}) relative to the carbon fiber radiator, which was submerged in water to simulate space plasma. This receiver was successfully tested for 95 days of operation [7], [11].

5. ASSEMBLY DEMO AND TECHNOLOGIES

One of MRHE's major deliverables was a concept assembly demonstration in the Lockheed Martin Advanced Technology Center (LMATC) Robot-Satellite facility. The goal of the MRHE testbed concept demonstration was to illustrate in hardware the fundamental guidance, navigation, and control functions needed to operate autonomously. LMATC leveraged a sizeable and capable infrastructure consisting of a test facility and test vehicles developed using LM internal funding. This infrastructure was complemented with LMATC-designed boom deployment mechanisms funded by LM IRAD, and augmented with MRHE-specific hardware and software. Part of the MRHE hardware was custom-designed, part provided through off-the-shelf hardware procurements, and part (the deployable booms) provided by LMATC's ATK subcontractor. The MRHE effort at the ATC benefited from tremendous synergies with prior LM internal investment in basic technology and infrastructure. These were essential to the successful completion of the ambitious MRHE concept demonstration within a short schedule and modest funding.

Advancements in technology attributable to this effort included: (1) Customization and implementation of a real-time path planning system that can be used to orchestrate safely a sizeable number (in this case, three) vehicles maneuvering in a coordinated fashion in close proximity to one another; (2) Design and implementation of a flight-like boom that can undergo repeated deployment / stow sequences; and (3) Design and implementation of an automated and autonomous guidance, navigation, and control system. This GN&C system provides each vehicle with the capabilities to rendezvous and dock with one or more vehicles, to maintain internally and update the state and topology of the docked configuration, including the state of the deployed boom length, to reconfigure vehicle control systems autonomously as aggregate systems change configurations, and to recognize and recover from a simulated fault which results in a failed docking attempt. Details of this assembly demo can be found in the Lockheed Martin ATC final report [8].

Technology Development for the Concept Demonstration

Control and Automation Laboratory Infrastructure—The MRHE assembly demo took place in the Controls and Automation Laboratory at the Lockheed Martin Advanced Technology Center in Palo Alto, CA. The laboratory assets include a 12' x 24' granite air-bearing surface for the simulation of zero-gravity operations, a custom pseudo-starfield for the emulation of star-tracker-like navigation, numerous robotic vehicles, and associated computing and wireless communications infrastructure, including a standard PC "ground station." The 50-kg robotic vehicles, shown in Figure 13, are equipped with upward-looking cameras emulating star trackers, pneumatic thrusters, reaction wheels, sensors, computation, wireless communications, and power. All of these components have been developed under Lockheed Martin internal funding (IRAD or fixed assets); additional components were developed for the MRHE demonstration.

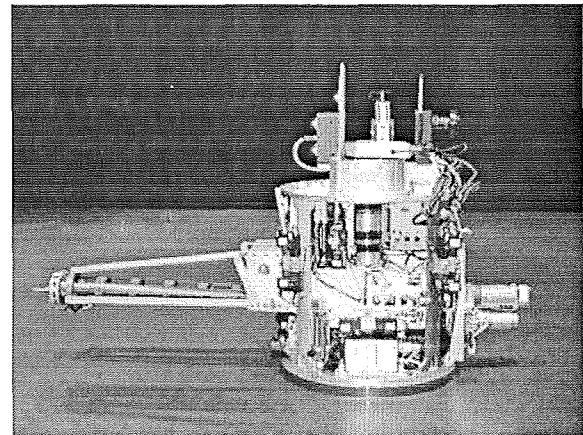

Fig. 13 LMATC Robotic Vehicle for MRHE Operations

MRHE Components—It was necessary to create a number of components and add them to the existing laboratory assets in order to complete the MRHE technology demonstration. The mechanical components include side-looking docking cameras and targets used for vehicle relative position sensing, the docking latches used to mate the vehicles, deployable booms, and deployable boom mechanisms. New ground station software includes both a sophisticated motion planner and an operator interface. The majority of the new software resides on-board the vehicles in the form of guidance and control algorithms, task planners and schedulers, and configuration management tools.

Vehicle Relative Sensing System—Because actual spacecraft would likely not have access to global position information such as that provided by the laboratory star-field system, realistic demonstrations of rendezvous and docking behaviors require an onboard relative sensing system. The system chosen for MRHE is an optical system utilizing a side-looking camera on the active docking vehicle and a passive LED target on the target vehicle. The docking camera runs a Lockheed Martin-developed software algorithm that uses the location of the three LEDs in the image to determine the relative position and orientation of the target and the camera. The camera sends the relative range, heading, and bearing information to the vehicle, which then uses the known location of the camera and target on the vehicles to determine the relative position and orientation of the vehicles themselves.

Docking Latches—The motorized latch developed under MRHE is an adaptation of an earlier Lockheed Martin design for a highly precise and repeatable kinematic latch. While the requirements for such a device differ significantly from those for a spacecraft mechanical docking interface, the availability of pre-existing hardware and documentation greatly accelerated fabrication and integration for the Phase I assembly demonstration. This latch consists of an active component mounted to the chaser vehicle in the docking scenario and a passive half mounted to the target vehicle.

Boom Assemblies—Deployable boom assemblies were integrated into two of the three vehicles. The vehicles, when docked together, can then vary their center-to-center spacing to create an expandable aggregate structure. A total of three booms were purchased as part of the effort, the third being used for bench-top testing with the Lockheed Martin designed and built deployment mechanism.

The three 2.5"-diameter, 92"-long booms built by ATK for Phase 1 employ CRT (Collapsible Rollable Tube) technology developed by ATK for Lockheed Martin under an earlier, separate effort and later refined for MRHE. The goal of the CRT technology is to achieve a deployable and retractable, flight-like boom with a high packing ratio and good stiffness/weight characteristics throughout its deployable range.

The deployment mechanism shown in Figure 14 was developed by Lockheed Martin under a parallel but separate internal research and development (IR&D) effort and features a positive traction drive, encoder-based position control, and end-of-travel/homing switches. A deployable length of 1.5 meters was achieved for the MRHE demonstration. After completion of the docking sequence and reconfiguration of the vehicle controller, the boom may be deployed and retracted repeatedly to any desired length within its range. The deployment sequence lasts approximately 30 seconds with a maximum deployment speed of 2 cm/sec. Details of the MRHE assembly boom and deployer are provided in [12].

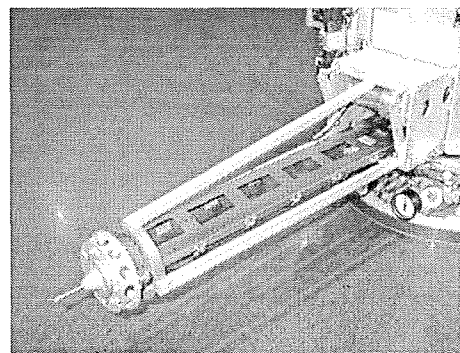

Fig. 14 Boom deployment mechanism in fully-retracted position

Ground Station and Communications Software—The ground station software has two primary purposes. The first is to provide the operator with telemetry from the vehicles showing status and other information, and to provide the user with an interface with which to command the vehicles. The second is to run the motion planner for the vehicles, which allows them to start in random positions and orientations and still find their way to their appropriate pre-docking locations.

Integrated into the ground station and vehicle software is a custom communications manager, which automatically generates communications sockets with the vehicles, whenever they come online. Telemetry from the vehicles consists mostly of the report messages. The vehicles also issue commands to one another, but not to the ground station. The only periodic message sent by the ground station is a timing synchronization signal that the vehicles use to set their local clocks.

Motion Planner—The primary software component of the ground station is the integrated motion planner. It is the job of this planner to take the initial starting locations of the vehicles at the beginning of the demonstration sequence and plan collision-free trajectories to get them to their designated starting locations, in an evenly-spaced line near the center of the table. The decision to place this planning task on the ground station was made for two reasons. First, a

centralized planner is simpler to implement, as it does not have to deal with the complexities of sequential planning, voting, or other methods used for distributed task planning. Second, memory limitations with the current vehicle operating system preclude the use of this particular planner onboard the vehicles themselves. It is important to note, however, that there is conceptually no difference between locating a centralized planner on the ground station as opposed to onboard a mobile vehicle.

The particular planner implemented for MRHE is a Randomized Kinodynamic Motion Planner (RKMP), adapted from the planner developed at the Stanford University Aerospace Robotics Laboratory. Randomized motion planners offer a couple of advantages. They are extremely fast, which is critical for applications involving vehicle motion in dynamic, changing, or otherwise unpredictable environments. In addition, while the plans themselves are random, performance is actually somewhat predictable. Details of the motion planner, controller design, and demo execution can be found in [13].

For the MRHE demonstration, planning for the multiple vehicles was handled sequentially, with priority depending upon the distance of each vehicle from its goal location. Once a vehicle is planned, it is treated as a moving obstacle by all remaining vehicles. Motion planning with extended objects – such as the MRHE vehicles with the extended booms – presents challenges in collision checking and rotation control during planning.

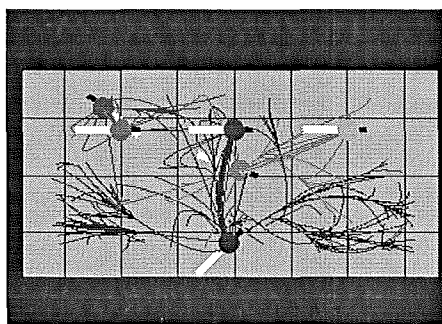

Fig. 15 Motion Plan

Figure 15 shows the GUI display of the complete planning trees returned by the motion planner during one run of the MRHE demonstration scenario. The darker versions of the vehicle icons correspond to the initial locations and orientations, while the brighter versions represent the goal locations (all in a line). The trees of explored motion segments are clearly visible. The tree for the blue vehicle is the largest because it is planned last, requiring it to dodge the other vehicles and resulting in a more-difficult planning task.

Controller Design—The controller is the most complicated software module, whose functions include: (1) Determining

the control mode (Off, Stationkeeping, Trajectory Following, Docking, or Slave Mode), (2) Determining the proper regulator and estimator based upon control mode and physical configuration, (3) Updating the estimators from the appropriate sensors, (4) Determining the vehicle position and velocity setpoints, (5) Calculating vehicle position and velocity error, and (6) Computing applied control from the state error.

The full-state regulators used for the vehicles were designed using standard Discrete Linear Quadratic Regulator (DLQR) methods. In addition to the position and velocity feedback, these regulators have been enhanced to include optional integral terms with saturation cutoffs and optional position and velocity deadbands. The controller sends the output of the regulators to the vehicle actuators. Desired torque is sent directly to the reaction wheel, while the thrust vector is sent through an optimized thrust mapper and a software pulse-width modulation module to be applied to the thrusters. For solo vehicles, only the reaction wheel is used to generate torque, in order to minimize fuel use.

Both stationkeeping and trajectory-following use exactly the same regulators and estimators, differing only in the choice of setpoint and the use of feedforward. In the MRHE implementation, each trajectory is a variable-length list of individual motion segments. This is the same trajectory format (and code) as is used on the ground station for the motion planner, and it naturally allows stationary, constant velocity, and constant acceleration segments.

The docking controller operates slightly differently from the stationkeeping and trajectory following controller, in that the position and velocity setpoints are commanded merely based upon relative position of the docking vehicle with respect to the target. This relative position and orientation information comes directly from the docking camera/target pair, and the docking controller does not use any information from the vehicle upward-looking camera system. A separate Kalman filter computes relative velocity information. A minimum closing velocity has been set to overcome the slight resistance in the spring-loaded latch jaws to passage of the probe. In the event that the docking vehicle moves outside of a narrow approach cone, the controller changes strategy and turns off the longitudinal regulator and the vehicle simply shifts laterally until back within the approach cone.

Control Reconfiguration and Multi-body Control—Autonomous control reconfiguration to account for changes in vehicle topology and dynamics is one of the key functional capabilities of the MRHE technology demonstration testbed. The first requirement for such reconfiguration is knowledge of the current vehicle and system configuration. In MRHE this was accomplished through the use of a software entity called the Connectivity Manager (CM). The CM has an internal model of the connectivity of itself and all other vehicles: in other words,

which vehicles are moving solo and which are currently docked to each other, and in what relative location.

Once the connectivity map with other vehicles is established, each vehicle uses its own location in the map to determine its role: solo, master in an aggregate structure, or slave in an aggregate structure. This in turn dictates which controller is applied. A three-vehicle aggregate can use up to three independent thrust vectors applied at the individual vehicle center of gravity locations, and the sum total of all three reaction wheels. Sensing and estimation for the aggregate vehicle is accomplished using the sensors on the lead vehicle only, and the setpoint is applied at that vehicle center of gravity.

Task Engine and Event Sequencing—The final major component of the vehicle controller architecture is the task engine, which is responsible for all event-sequencing throughout the demonstration. The structure of the task engine is primarily that of a sequenced list. In general, each vehicle will have a parallel, although potentially different, set of tasks within its task sequence. Simultaneous advancement through the task lists is accomplished by designating one vehicle as the lead for each particular task entry. Upon task completion, the lead vehicle then radios the other vehicles to advance to the next task.

Assembly Concept Demonstration

The intent of the MRHE concept demonstration was to demonstrate both the feasibility of the fundamental technologies necessary to autonomously assemble large space structures and to show significant initial implementation of these technologies on a representative testbed. The final demonstration sequence was executed in a fully autonomous manner by the vehicles.

Motion Planning to Goal Locations—At the beginning of the demonstration, each vehicle starts in an unknown random location and orientation. After determining their location and heading on the table, they radio this information to the system ground station computer. The ground station uses the Randomized Kinodynamic Motion Planner to plan paths for each vehicle to its prescribed goal location, while avoiding all potential obstacles. In this case, the prescribed goal configuration is a line of three evenly-spaced vehicles, all facing the same direction.

Trajectory Following to Goal Locations and Failed/Aborted Docking Attempt—At a command from the ground station, each vehicle proceeds along the trajectory plan to the desired goal location. The first docking maneuver is attempted. In this case the docking fails because this particular target vehicle purposely does not have the appropriate docking probe, effectively mimicking a hardware failure that the system must first detect and then recover. The docking vehicle times-out of its docking

attempt and automatically executes a back-off maneuver to put a safety buffer between it and the target.

Vehicle Location and Role Exchange—Because the previous docking attempt could not take place, the two vehicles now change locations and switch roles, docker vs. target, for a new docking attempt. In this case the maneuver and system reconfiguration is scripted, and is effectively hard-coded within the vehicle task engines. Development of fully-autonomous fault-detection and correction strategies was planned for Phase II of MRHE.;

Docking with Controller Reconfiguration—After the reorganization above, the demonstration sequence proceeds as if the task sequence had been uninterrupted, but with two of the vehicles now in different roles. The new docking vehicle now docks with the new target vehicle. After successful docking, the docking vehicle examines the sensors in its latch mechanism to determine that it is now latched onto another vehicle, and announces this event to the other vehicles. The vehicles then compare their knowledge of their relative physical “connectivity” so that each vehicle knows who is connected to whom.

Using this connectivity information, the docking vehicle relinquishes control to the target vehicle to which it has docked. The target vehicle assumes the leading role in a master-slave control configuration, and reconfigures its regulators and estimators to account for the new mass and inertia properties of the aggregate vehicle, the change in center of gravity location, and the additional actuators available to it from the second vehicle. Thereafter the lead vehicle computes the necessary control for both itself and the follower vehicle, and radios to it the desired reaction wheel and thruster commands.

Cooperative Docking—The two-vehicle aggregate now docks with the third vehicle using the new master-slave controller configuration. After docking the vehicles again compare connectivity and reconfigure their respective control strategies accordingly. In this case, the center vehicle retains control of the aggregate, while the two end vehicles act as followers.

Boom Deployment, Multi-Body Lateral Translation, and Boom Retraction—The Lockheed Martin-supplied deployment mechanisms now deploy the booms connecting the three vehicles, half a meter each to obtain a center-to-center spacing of over 1.5 meters. During the deployment, the lead vehicle senses the boom length and adjusts its control gains to accommodate the change in vehicle inertia and maintain stability, while stationkeeping at its current location.

The aggregate vehicle translates 0.5 meters laterally, followed by stationkeeping at the new location. Each vehicle contributes to the control necessary for the maneuver.

Following the conclusion of the fully-autonomous sequence, the booms are retracted to their stowed configurations.

MRHE Assembly Demonstration Summary

The Lockheed Martin Advanced Technology Center provided a successful assembly concept demonstration which met the demonstration requirements established by LM and MSFC. This demonstration, which entailed a substantial hardware and software integration task and testbed demonstration, was brought to fruition in a very limited timeframe and budget.

6. MRHE ACCOMPLISHMENTS AND SUMMARY

Accomplishments during the Phase I MRHE project include advances in concept definition for high-voltage modular 100kWe-class solar electric propulsion satellites, testing that provided characterization of the superior thermal management performance of Supertubes, the selection of recommended radiation-hardened concentrator lens material for transport through the Van Allen belts, advancements in the design and testing of 600V PV arrays, and a successful autonomous ground demonstration of assembly and operations for an MRHE-like configuration.

The configuration trade of tetrahedral versus linear modular configurations was done early in Phase I. The selection of the linear solar clipper configuration without power transfer between modules eliminated the requirement for power-conducting joints for JPL's Power Delivery System. Orientation trades resulted in the perpendicular-to-orbit-plane (POP) orientation, providing the requirements for the detailed preliminary bus concept, and determining the number of booms, solar array locations, etc. A spacecraft mass estimate was provided to JPL for trajectory analysis and propellant requirement estimates. The launch vehicle trades and phasing orbit/proximity operations trades performed by Boeing provided detail needed for the concept of operations development, mission design, and the assembly scenario. These details were captured and animated in a video of MRHE assembly and SLASR deployment developed by SAIC.

UAH's thermal testing has shown that the thermal conductivity of Supertubes is at least 10,000 times that of copper for short lengths, and at least 30,000 times that of copper for longer lengths. Their testing has also confirmed a consistent temperature threshold for activation of superconductor properties. They found that superconductivity capability is lost if the Supertube is punctured. UAH concluded that for a specified heat load, Supertubes are significantly lighter, had smaller diameters, and offered higher effective thermal conductivities than known heat pipes, enabling redundancy capability in designs. UAH also developed several concepts for joining Supertubes for either assembly of heat pipes across module

units, or for by-pass repair of breached tubes. Their testing determined that the performance of some Supertubes is gravity-dependent, which would not be suitable for space applications; however, this information is valuable for future specifications of Supertubes from the vendor. UAH also discerned that Supertube units are available for at least three temperature ranges.

ENTECH addressed two issues of SLA use for MRHE: the radiation-hardening of concentrator lenses, and the development and testing of encapsulation processes for long-term operation of PV cells at 600V. Their testing of POSS materials for radiation resistance determined that coated silicone lens material is still the recommended approach for SLA lenses. ENTECH also fabricated encapsulated cells and successfully tested them for 95 days of underwater exposure, documenting manufacturing and repair processes. They have continued to test these cells beyond the end of the MRHE project. In addition, ENTECH developed a detailed software model of SLA solar power generation, for use in the JPL MRHE Simulation Platform.

Lockheed Martin Advanced Technology Center provided a highly successful assembly demonstration of three robotic satellites in a solar clipper linear configuration, complete with the deployment and retraction of flight-like lightweight booms. Highlights included autonomous vehicle path planning and execution, autonomous GN&C capabilities, autonomous reconfiguration, sensor configuration changes, automated docking, self-assembly, fault detection and recovery, wireless communication between a ground station and the modules, and the deployment and retraction of booms integrated on the vehicles. Technology advancements included the manufacturing of three ATK CRT booms, the LM IRAD-funded boom deployment mechanisms, and the successful vehicle-integration of booms, docking cameras, docking targets, docking latches, GN&C and control planning and proximity operations algorithms and software.

7. ACKNOWLEDGMENTS

The authors would like to acknowledge the significant work done by John Blumer and Lee Huffman of Boeing Huntsville, James Blackmon and Sean Entekin of UAH, Mark O'Neill of ENTECH, and David Schaechter, Nelson Pedriero, Fred Rehnmark and Ed LeMaster of Lockheed Martin ATC. In addition, the authors would like to recognize the contributions of the MSFC team of Ramona Cummings, Mark Gerry, Louis Lollar, Mark Cox, Ed Litkenhaus, Ricky Howard, Joe Bullington, Tymaine Whitaker, and Kathy Brown.

REFERENCES

- [1] John Mankins, "Solar Power From Space: The Worldwide Grid of the Future", Electrical Line, May-June 2000.
- [2] Mike Jahan and Neville Marzwell, Modular, Reconfigurable, High-Energy Technology Demonstrator Project, JPL Final Report, MRHE-2006-001, April 30, 2006.
- [3] Michael Piszczor, MRHE-GRC Thin-Film High Voltage Testing Final Report, April 21, 2006.
- [4] Connie Carrington and Joe Howell, Modular, Reconfigurable High-Energy Technology Demonstrator, MSFC Final Report, April 30, 2006.
- [5] John Blumer, Lee Huffman, et. al., Modular, Reconfigurable, High-Energy Technology Demonstrator Concept Development and Preliminary Design, Boeing Final Report, Contract No. NNM05AA96C, April 28, 2006.
- [6] James Blackmon and Sean Entrekin, Advanced Space Radiator for High Concentration Solar Photovoltaic Array Thermal Control and Modular Reconfigurable High Energy Project, University of Alabama in Huntsville Propulsion Research Center, Interim Final Report, Contract No. F/NAS/MSFC/NSSTC/9.3.2, April, 2006.
- [7] Mark O'Neill, Advancement of Stretched Lens Array (SLA) Technology for Exploration Missions, ENTECH Final Report, Contract No. NNM05AA98C, April 14, 2006.
- [8] David Schaechter and Nelson Pedriero, Modular, Reconfigurable, High-Energy Technology Demonstrator Assembly Testbed, Lockheed Martin Advanced Technology Center Final Report, Contract No. NNM05AA99C, February 13, 2006.
- [9] Greg Day, High Power Technology Demonstration Spacecraft Phase II Final Report, The Boeing Co., May 31, 2004.
- [10] James Blackmon and Sean Entrekin, "Preliminary Results of an Experimental Investigation of the Qu Superconducting Heat Pipe," to be published in a Technical Note in AIAA Journal of Propulsion and Power, 2006.
- [11] Mark O'Neill et. al., "Stretched Lens Array Square Rigger: A New Space Array for High-Power Missions," Fourth World Conference on Photovoltaic Energy Conversion, Waikoloa, HW, May 2006.
- [12] Fredrick Rehnmark et. al., "Development of a Deployable Nonmetallic Boom for Reconfigurable Systems of Small Modular Spacecraft," 48th AIAA Structures, Structural Dynamics, and Materials Conference, Waikiki, HW, April 2007.
- [13] Edward LeMaster, David Schaechter, and Connie Carrington, "Experimental Demonstration for Autonomous On-Orbit Robotic Assembly," AIAA Space 2006 Conference, San Jose, CA, September 2006.

BIOGRAPHY

Connie Carrington was the Project Engineer for the MRHE project. She currently works in the Autonomous Rendezvous and Docking group at MSFC, and manages the Modular Sensor Suite. She has worked for MSFC for 17 years as a systems engineer, project manager, and GN&C engineer. She was a professor in the Mechanical Engineering Dept. of the University of South Carolina, and worked for Sperry Marine Systems, Pratt & Whitney Aircraft, and the University of VA. She has a PhD in Spacecraft Dynamics and Control from the Engineering Science and Mechanics Dept. of VA Tech.