

Abstract for Invited Talk in Cocoa Beach 2006 International Conference

Robust Joining and Integration Technologies for Advanced Metallic, Ceramic, and Composite Systems

M. Singh, Tarah Shpargel
QSS Group, Inc., NASA Glenn Research Center
Cleveland, OH 44135

G.N. Morscher
Ohio Aerospace Institute, NASA Glenn Research Center
Cleveland, OH 44135

Michael Halbig
US Army Propulsion Directorate
NASA Glenn Research Center
Cleveland, OH 44135

Rajiv Asthana
University of Wisconsin-Stout
Minomnee, WI

Robust integration and assembly technologies are critical for the successful implementation of advanced metallic, ceramic, carbon-carbon, and ceramic matrix composite components in a wide variety of aerospace, space exploration, and ground based systems. Typically, the operating temperature of these components varies from few hundred to few thousand Kelvin with different working times (few minutes to years). The wide ranging system performance requirements necessitate the use of different integration technologies which includes adhesive bonding, low temperature soldering, active metal brazing, diffusion bonding, ARCJoinT, and ultra high temperature joining technologies. In this presentation, a number of joining examples and test results will be provided related to the adhesive bonding and active metal brazing of titanium to C/C composites, diffusion bonding of silicon carbide to silicon carbide using titanium interlayer, titanium and hastelloy brazing to silicon carbide matrix composites, and ARCJoinT joining of SiC ceramics and SiC matrix composites. Various issues in the joining of metal-ceramic systems including thermal expansion mismatch and resulting residual stresses generated during joining will be discussed. In addition, joint design and testing issues for a wide variety of joints will be presented.

Robust Joining and Integration Technologies for Advanced Metallic, Ceramic, and Composite Systems

M. Singh, Tarah Shpargel, Gregory N. Morscher*, Michael H. Halbig**

QSS Group, Inc.

***Ohio Aerospace Institute**

****US Army Vehicle Technology Directorate**

NASA Glenn Research Center

Cleveland, OH 44135

Rajiv Asthana

Technology Department

University of Wisconsin-Stout

Menomonie, WI 54751

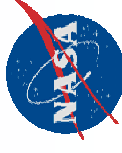

Outline

- Need for Joining and Integration Technologies
- Technical Issues and Challenges
 - *Joint Design and Analysis*
 - *Thermomechanical Issues*
 - *Testing and Evaluation*
- Active Metal Brazing (**Metals to Composites**)
 - *Microstructural Analysis*
 - *Mechanical Behavior*
- Diffusion Bonding (**Ceramic-Ceramic**)
 - *Joint Microstructure*
 - *Interfacial and Mechanical Characterization*
- Reactive Joining Using ARCJoinT (**Ceramic-Ceramic, Composites-Composites**)
 - *Joint Microstructure and Interfacial Analysis*
 - *Thermomechanical Performance*
- Applications
- Summary and Conclusions

Need for Joining and Integration Technologies

- Joining and integration technologies are key to development and utilization of advanced ceramics and composites in aerospace and ground based applications.
 - **Aerospace Systems**
 - *Aerospace and Space Propulsion Components (Combustor Liners, Exhaust Nozzles, Nozzle Ramps, Turbopump Blisks)*
 - *Thermal management systems (Radiators, recuperators), optical components, and dimensionally stable space structures*
 - **Ground Based Systems**
 - *Nuclear Industries, Land Based Power Generation, Process Industries, Heat Exchangers, Recuperators, Microelectronic Industries (Diffusion Furniture, Boats)*
- The development of robust joining and assembly capability will allow the application of advanced ceramics and composites technology in a timely manner.

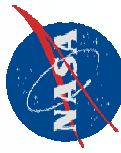

Technical and Performance Requirements for Joined Structures

- **Typically for the high temperature aerospace and ground based applications (ceramic and composite- based systems):**
 - Use temperature $> 1200\text{ }^{\circ}\text{C}$ (*joint properties comparable to base materials*).
 - Good thermomechanical properties (strength and oxidation resistance)
 - Low CTE mismatch to minimize residual stresses and good thermal shock resistance
 - Leak tight joints
- **In ceramic-metal systems, joint performance is limited by the temperature capability of metallic component in the system (brazed/bond layer, metallic substrate). These systems have operational capability around 700-800°C.**
- **Practical, reliable, and affordable technique adaptable to in-field installation, service, and repair.**

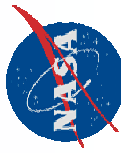

Robust Joining and Attachment Technologies

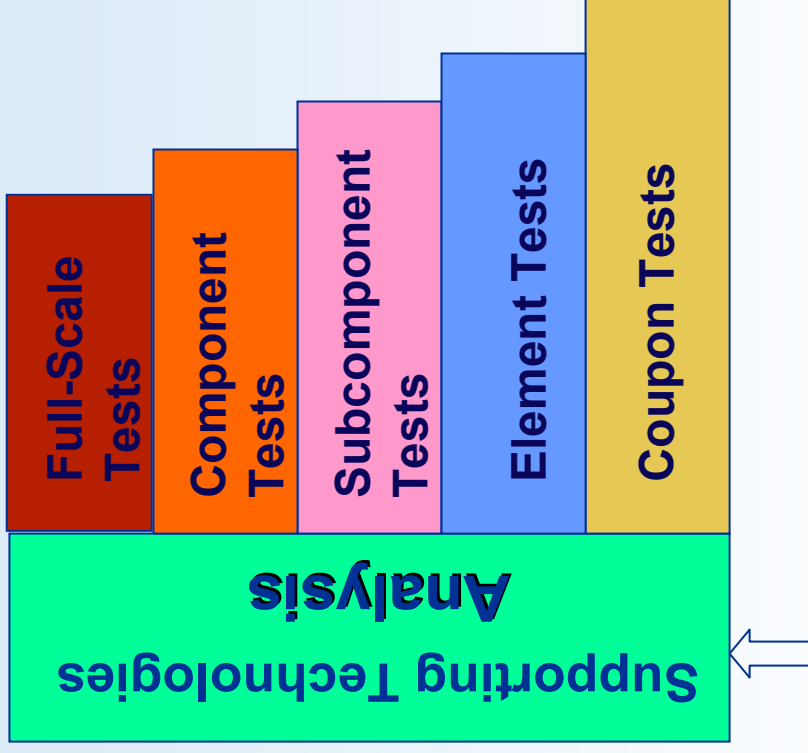

Design Considerations

***Opportunities to Utilize Building-Block Approach
to Design and Manufacturing of Large Ceramic and Composite Structures***

Active Metal Brazing of Metals and Ceramic Composites

Bonding of Metals to Ceramics and Composites Using Metallic Interlayers

Metallic Systems:

- Titanium
- Inconel and Other Ni-Base Superalloys
- Kovar
- Stainless Steels

Active Metal Brazing
Soldering

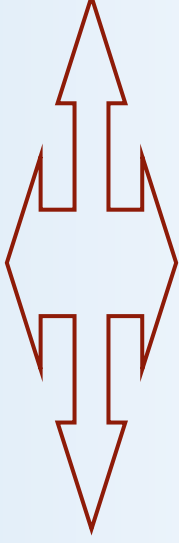

Ceramics/Composite Systems:

- SiC, Si₃N₄
- YSZ, Alumina
- C/C Composites
- C/SiC, SiC/SiC

Interlayer Systems:

- Active Metal Brazes (Ag, Cu, and Pd based)
- Metallic Glass Ribbons
- Solders (Zinc based)

Technical Issues:

- Melting range / behavior
- Wetting characteristics
- Flux or atmosphere compatibility
- Compositional compatibility
- Cost & availability

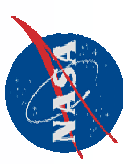

Nuclear Electric Propulsion Technologies are Critical for Space Exploration Missions

Power Management & Distribution



Heat Rejection

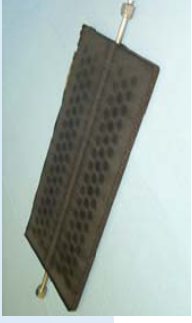

Science Payload



Power Conversion



Reactor Heat Source

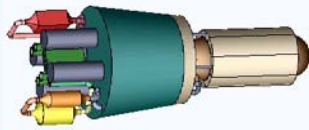

Electric Propulsion

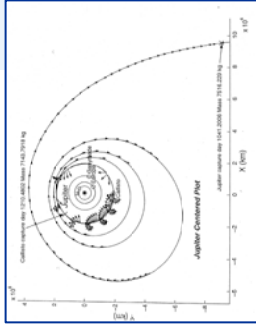

Trajectory Analysis

NEP Enables:
Outer Planet Orbiters (rather than Flybys)
Multiple Targets on Single Mission
High Power, Long Duration In-Situ Science
High Data Rate Communications

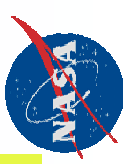

Joining and Assembly Needs in Heat Rejection System

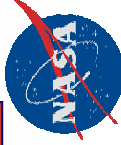
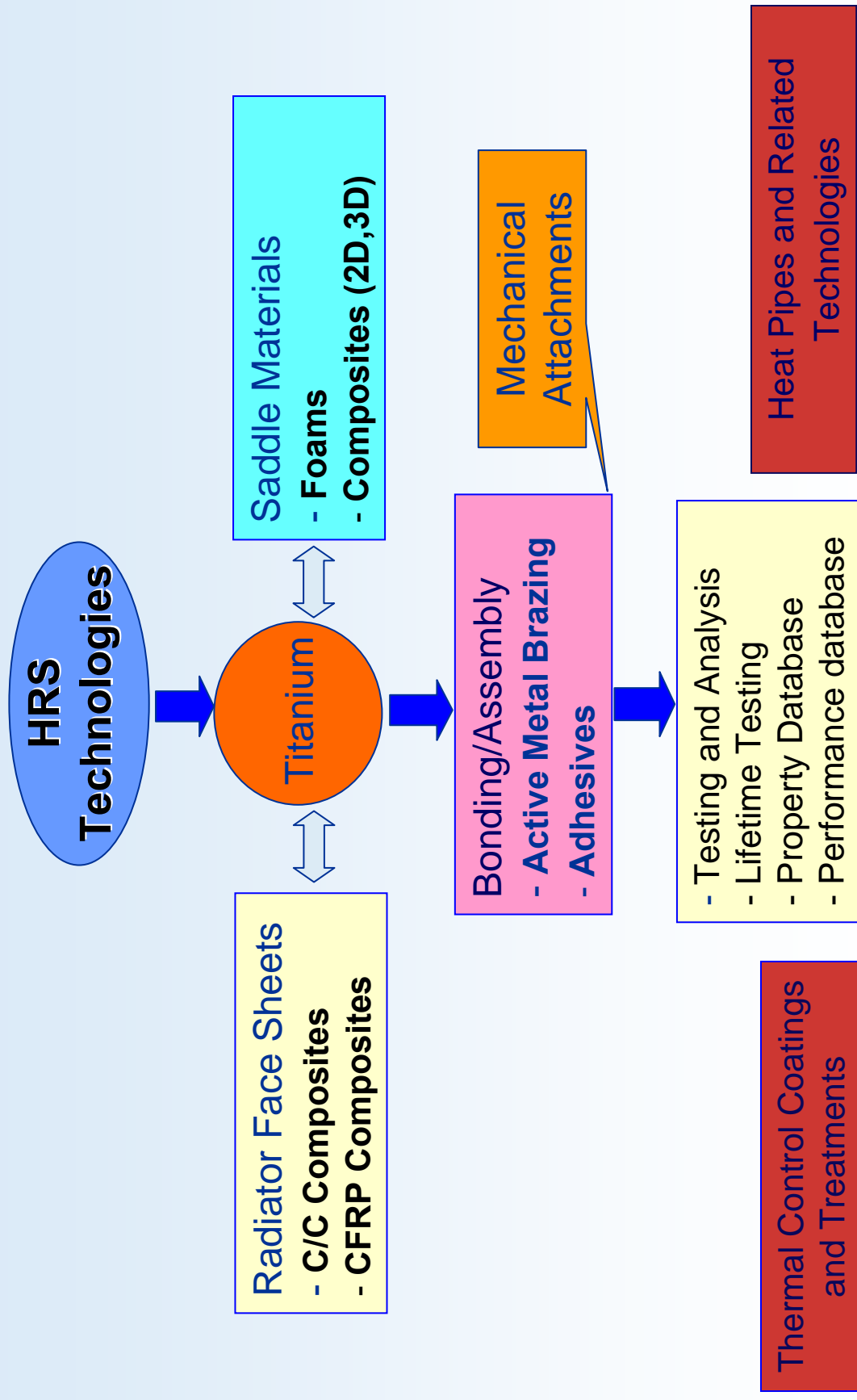

Brazed and Adhesive Bonded Sub-elements for Heat Rejection System

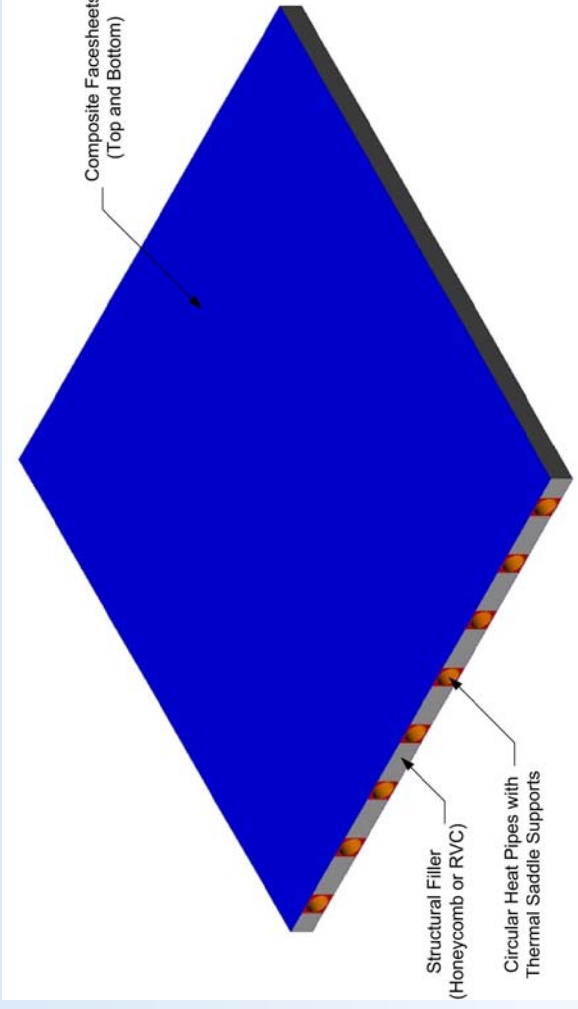

Adhesive Bonded Radiator Sub-element



Brazed Radiator Sub-elements

Thermal Expansion Mismatch Issues are Critical in Brazing of Metal-Composite System

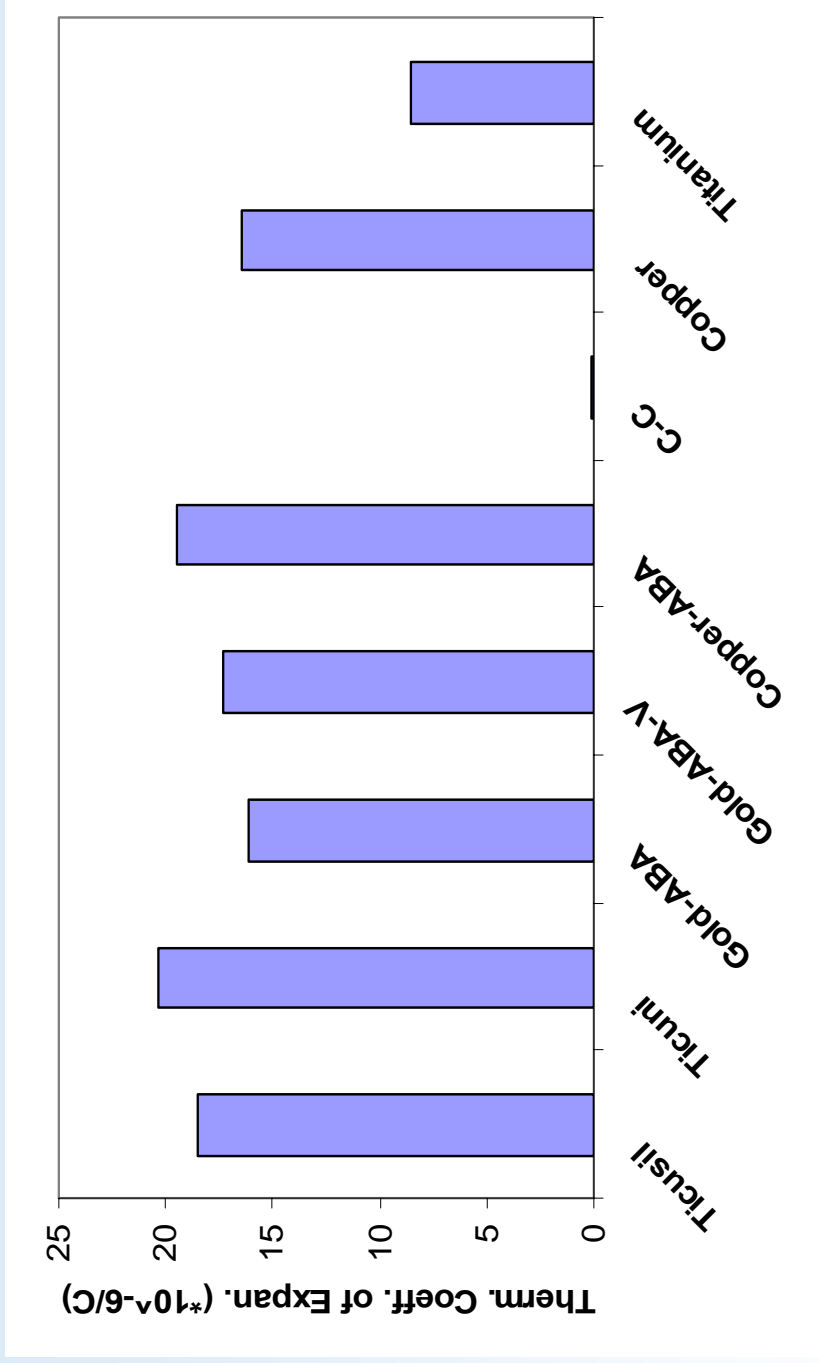

Innovative joint design concepts, new braze materials, and robust brazing technology development are needed to avoid deleterious effects of thermal expansion mismatch.

Active Metal Brazing

- Ti tubes and plates brazed to P120 CVI C/C composite (Goodrich)
- Several braze/solder compositions compared (processing Temp):
 - TiCuSil (910 C) foil and paste
 - CuSil-ABA (820 C) foil and paste
 - CuSin-1ABA foil (810 C)
 - Incusil foil (725 C)
 - S-Bond solder (~ 400 C)
- **Two tests have proved successful:**
 - Butt Strap Tension (BST)
 - Tube-Plate Tensile Test

- **Require good wetting, bonding and spreading properties**
- **Desire minimal residual stress induced cracking in C/C**

Microstructure of Brazed Ti and C-C Composites using TiCuSil and CuSil ABA Paste



Ti- Tube

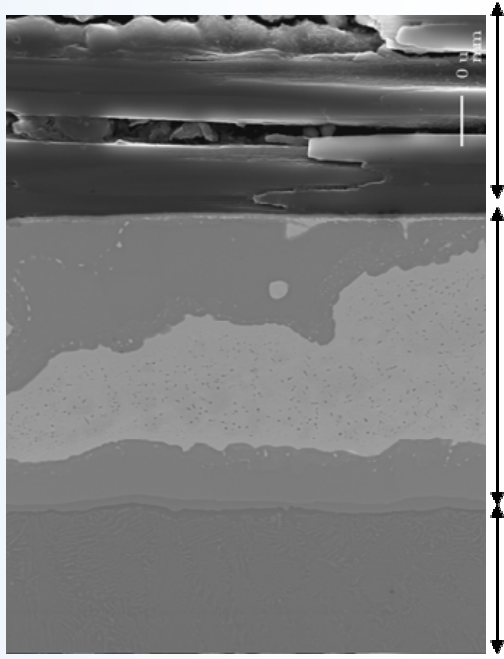

Ti- Plate

Titanium Plate

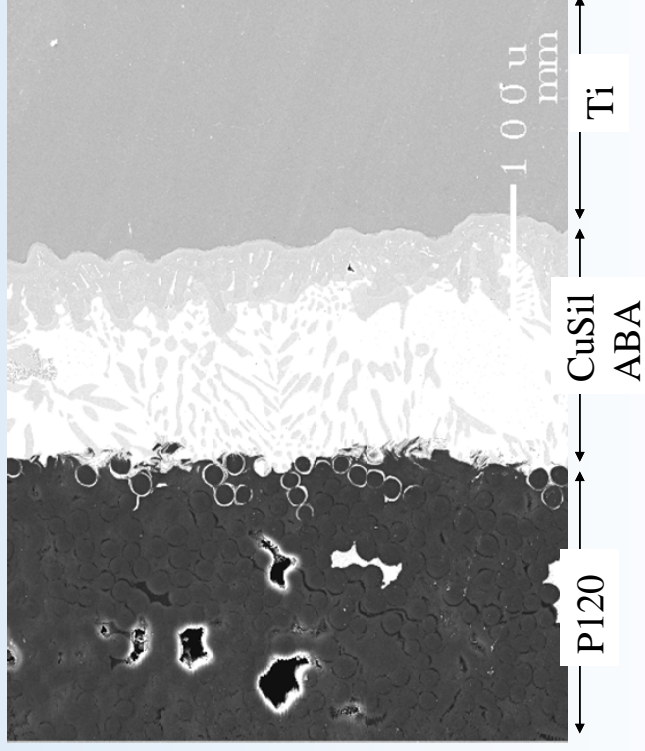

Microstructure of Joint Interface in Ti and C-C Composites Brazeed using CuSin ABA Foil

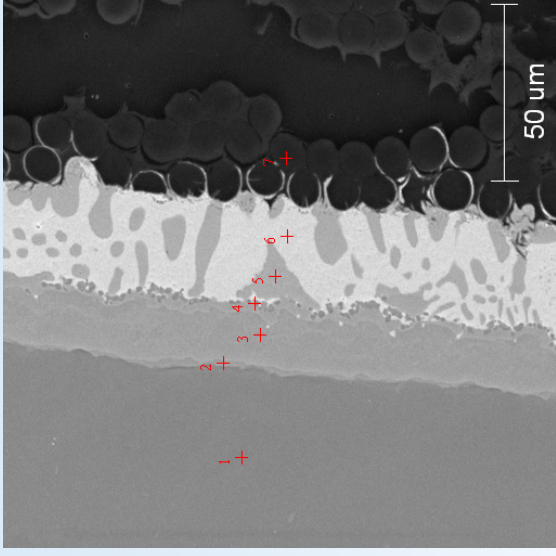
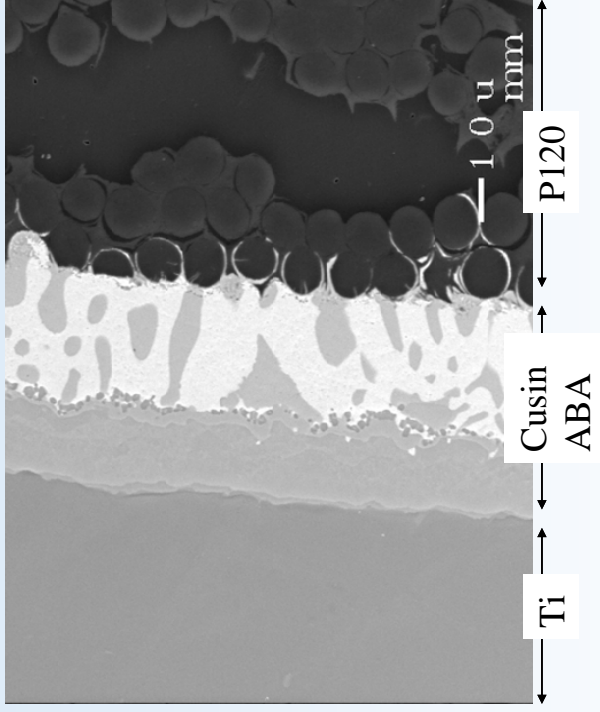

Composition:

- 1) 98% Ti, 1%Cu, 0.5% Ag, 0.5% Sn
- 2) 61% Ti, 36%Cu, 2%Ag, 2%Sn
- 3) 37% Ti, 59%Cu, 2%Ag, 2%Sn
- 4) 28% Ti, 47%Cu, 25% Ag
- 5) 3%Ti, 84%Cu, 13%Ag,
- 6) 1%Ti, 3%Cu, 96%Ag
- 7) 100% C

Mechanical Testing of Brazed/Soldered Joints

Tube Tensile Test

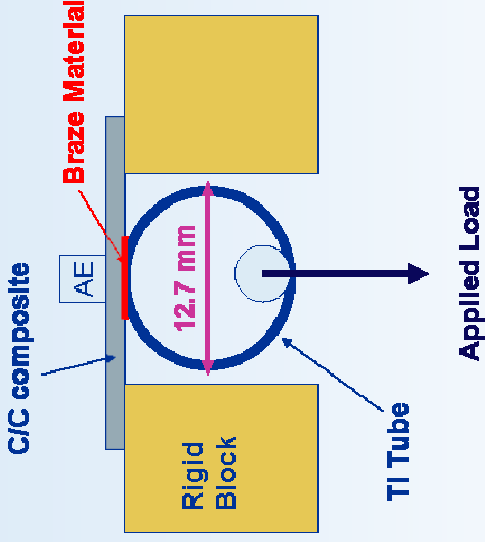

Butt Strap Tensile Test

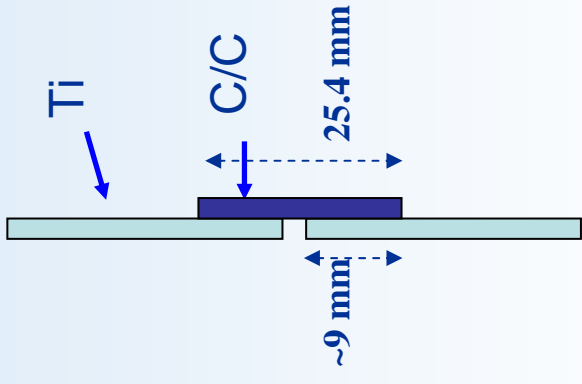

Factors to consider:

- Braze composition, Processing variables
- Bonded area, Location of failure
- Architecture effects

Tube Tensile Test Data for Brazeed Joints

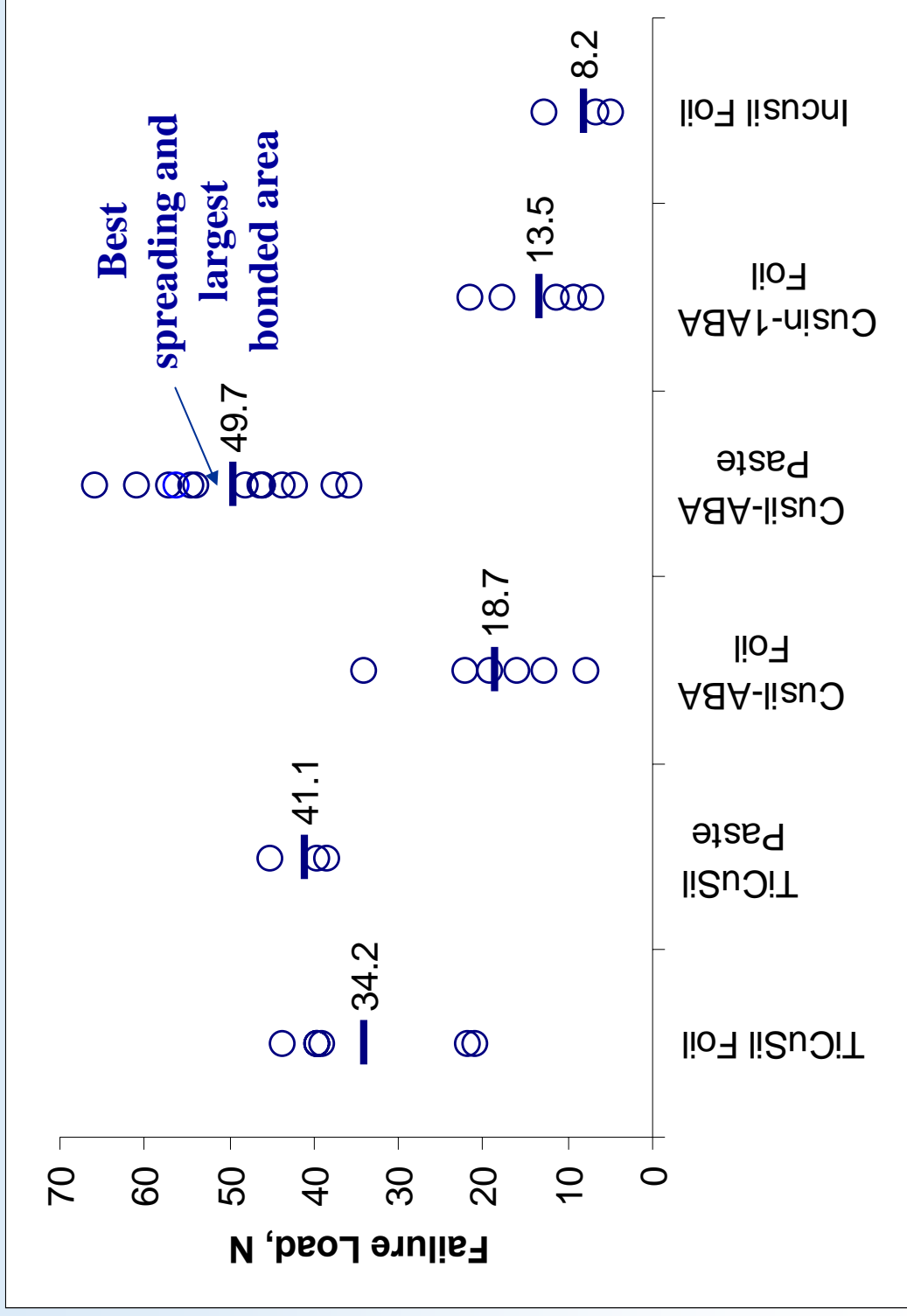

Failure Behavior of Ti Tube - C/C Composite Joints

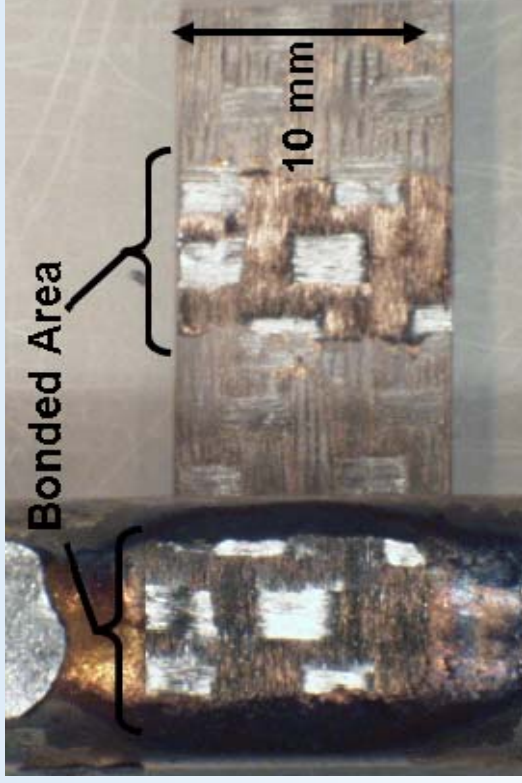

Tube and C/C plate fracture surfaces for CuSil-ABA paste braze material showing the bonded area of the outer ply of C/C brazed to the Ti tube (left) and C/C plate (right).

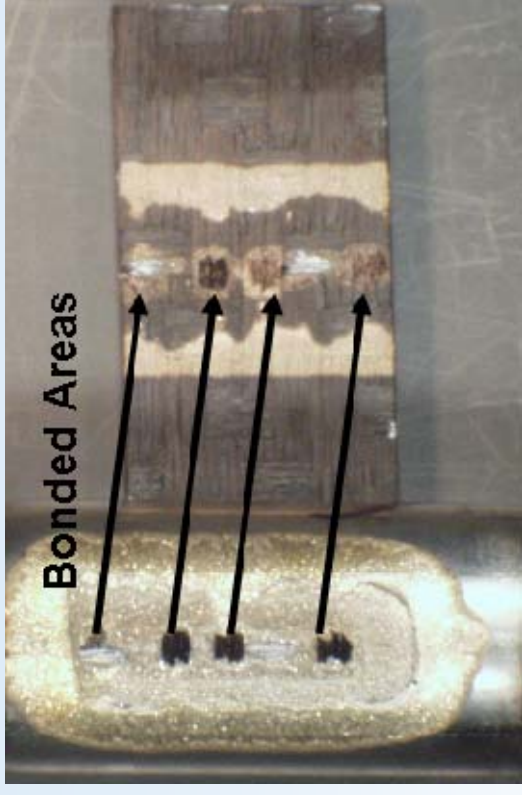

Tube and C/C plate fracture surfaces for Incusil ABA foil braze material showing the distinct bonded areas of the outer ply of C/C brazed to the Ti tube (left) and C/C plate (right).

Butt Strap Tensile (BST) Test Data

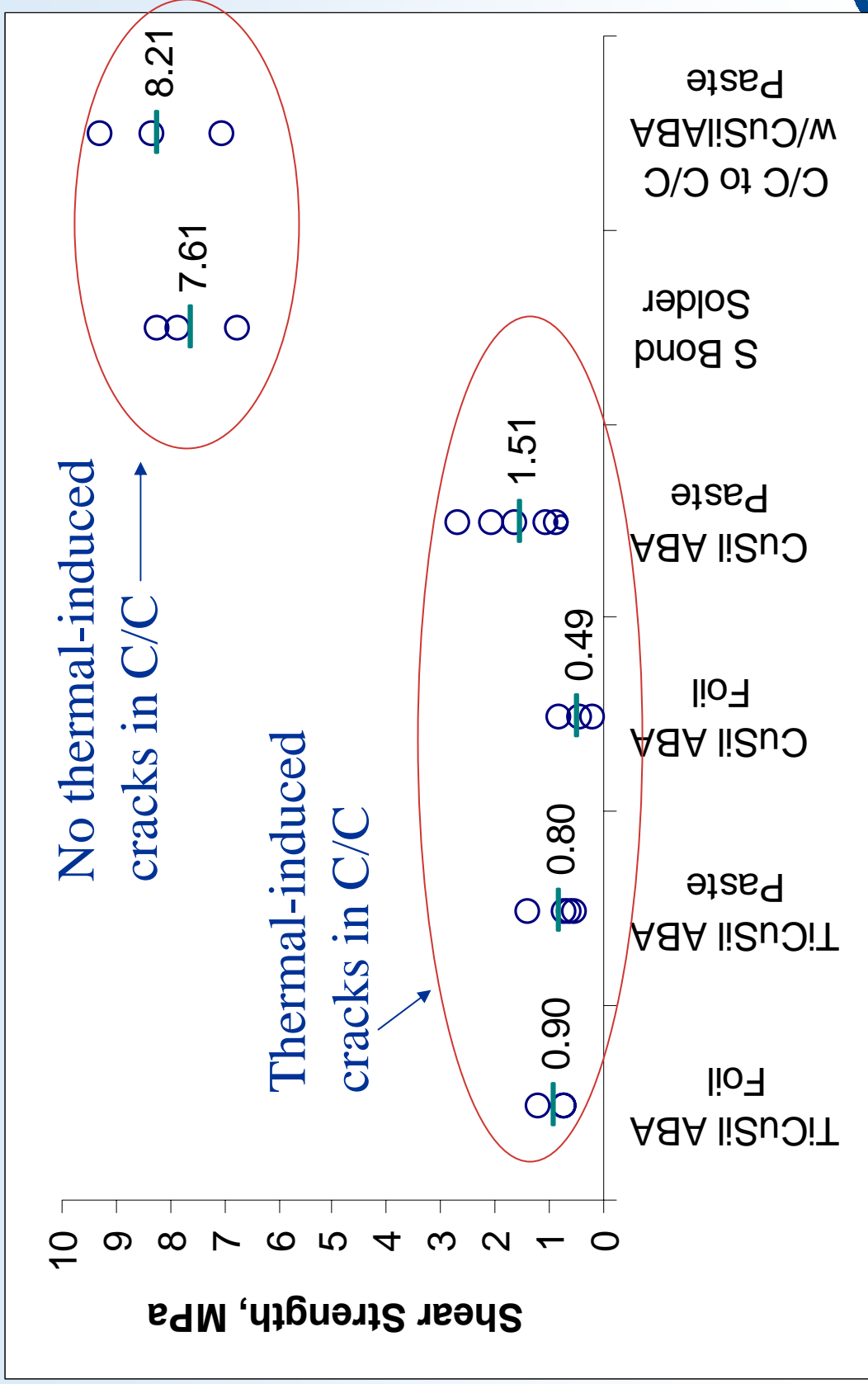

Thermally-Induced Cracking in C/C Controls Shear Strength of Brazed Joints

For braze materials where there was strong bonding between the braze and the C/C and failure occurred in the outer-ply of the C/C

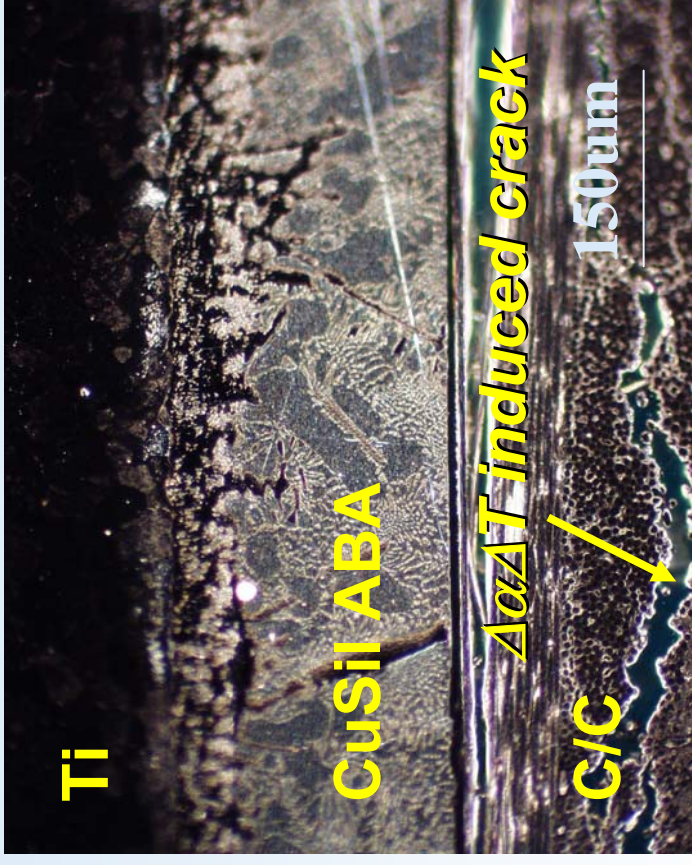
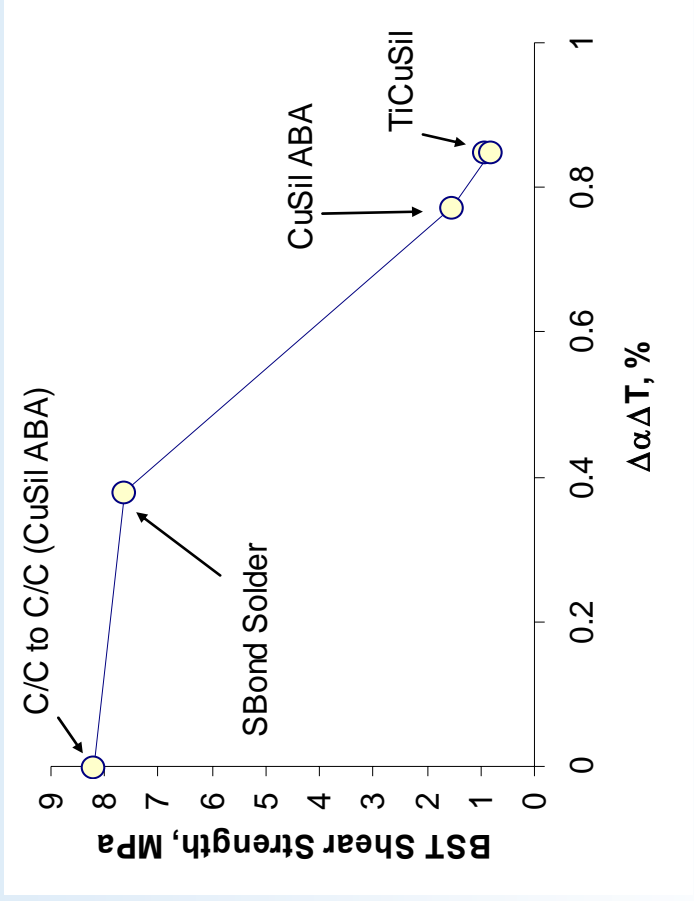

Joint Material	Proc. Temp., C
S-Bond	~ 400
CuSil ABA	830
TiCuSil	910

$$\Delta\alpha = \alpha (\text{Ti}) - \alpha (\text{C/C})$$

$$\Delta T = T (\text{liquidus} \sim \text{processing}) - 25^\circ\text{C}$$

Active Metal Brazing of C/C Face Sheet/Poco Foam/Titanium System

CuSil-ABA Braze Alloy

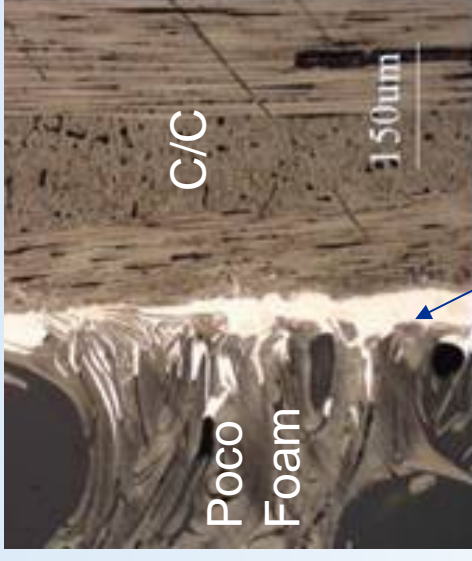
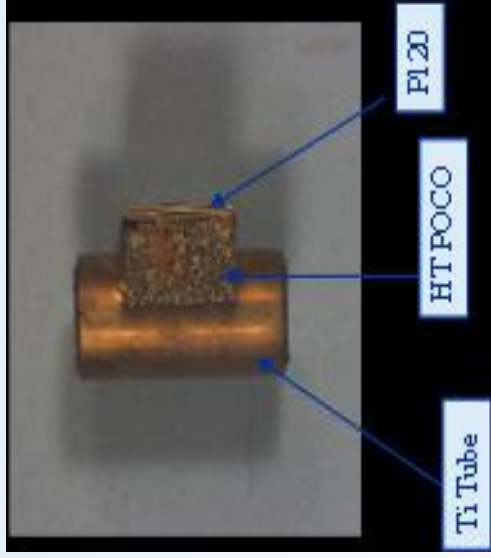

Brazed Joints

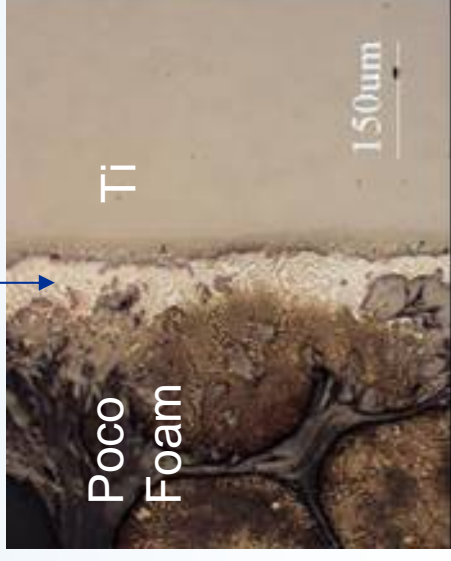

Locations of Potential Joint Failure in C/C Face Sheet/Poco Foam Saddle/Titanium

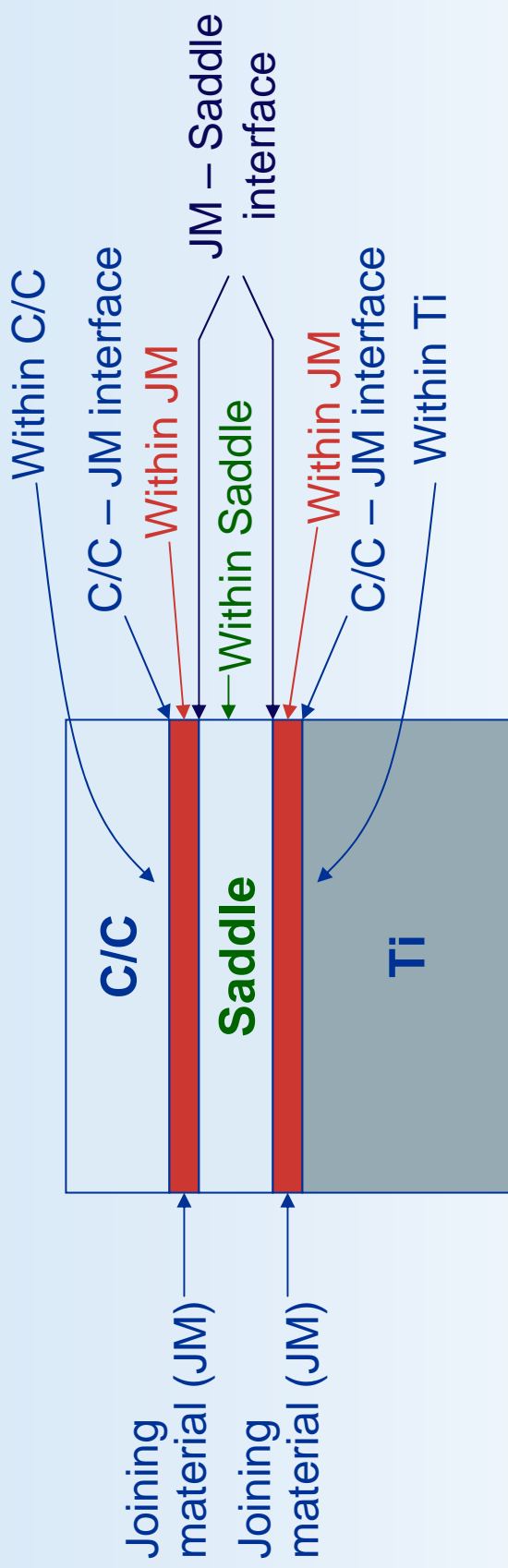

In addition the geometry of joining surfaces will affect strength of joint and influence spreading of joint material: flat to flat, flat to tube, curved surfaces...

Therefore, knowing the location of joint failure is critical

- **Weakest link requiring further improvement**
- **Affects interpretation of results (material or test-dependent property)**

Key factor: Bonded area dictated by braze composition and applied pressure, C/C constituent composition, fiber orientation, geometry of joined surface

Diffusion Bonding of Silicon Carbide Using Metallic Interlayers

Multi-Point Lean Direct Injector

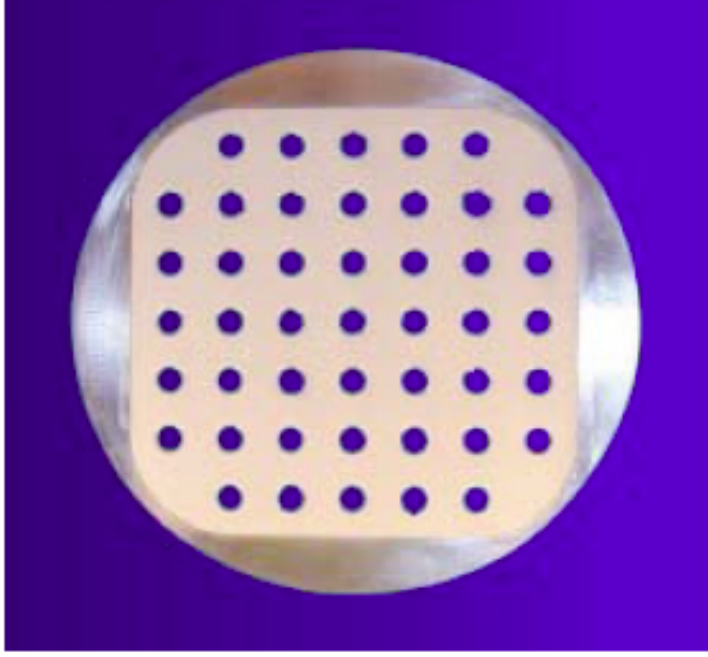
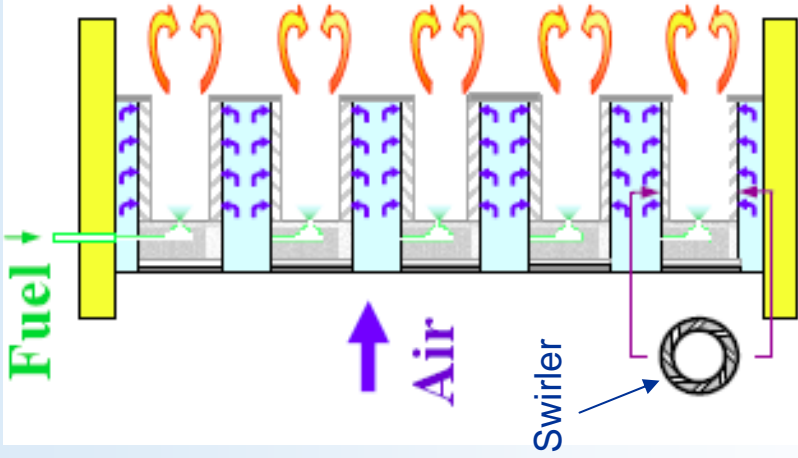

(Left) Multi-Point Lean Direct Injector accelerates fuel-air mixing and has small recirculation zones with short residence time that reduces NO_x emission.

(Center) 3-inch square metal MP-LDI with 45 injectors.

(Right) Detail of fuel and airflow.

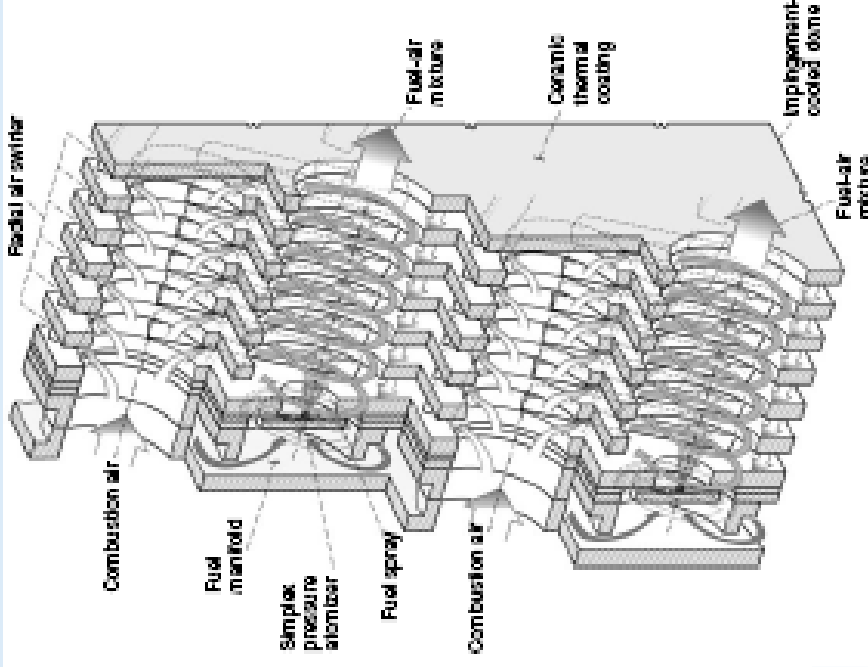

From Robert Tacina, et al., "A Low Lean Direct Injection, Multi-Point Integrated Module Combustor Concept for Advanced Aircraft Gas Turbines," NASA/TM-2002-211347, April 2002.

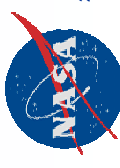

Lean Direct Injector Fabricated by Laminates

SiC laminates can be used to create intricate and interlaced passages to speed up fuel-air mixing to allow lean-burning, ultra-low emissions.

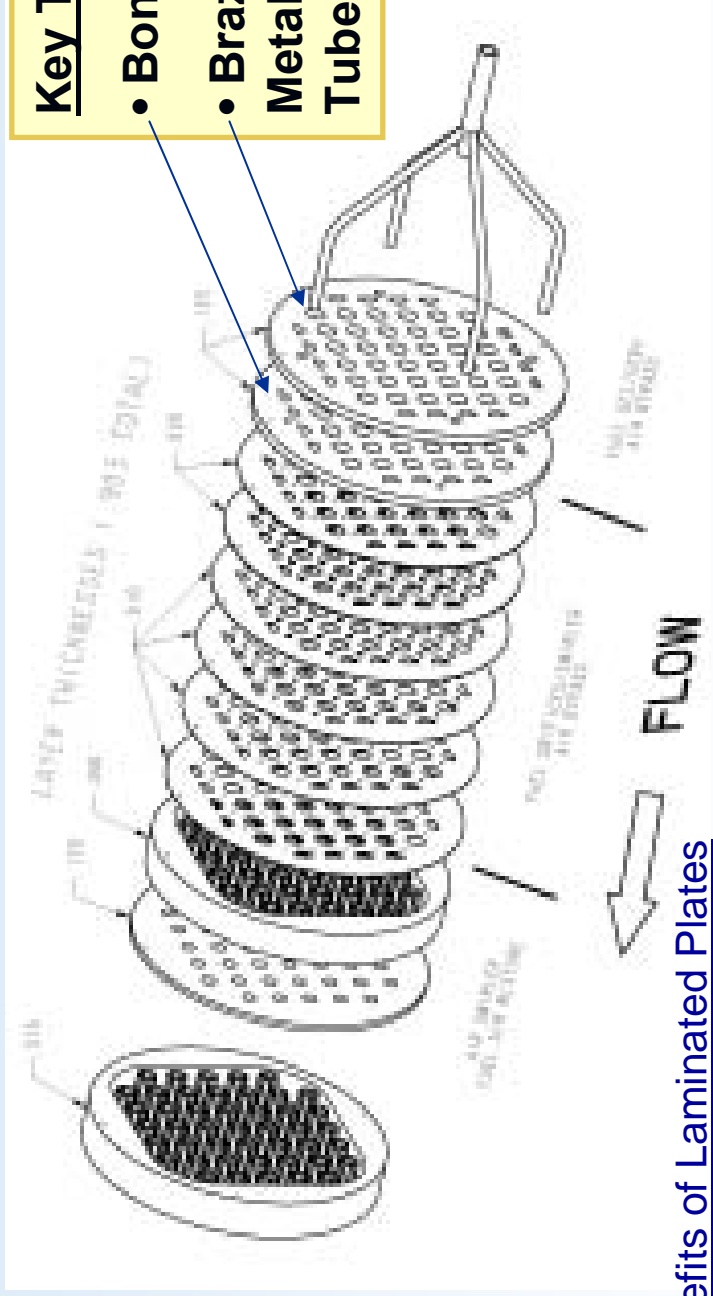

Key Technologies:

- Bonding of SiC to SiC
- Brazing of SiC to Metallic (Kovar) Fuel Tubes

Benefits of Laminated Plates

- Passages of any shape can be created to allow for multiple fuel circuits
- Provides thermal protection of the fuel to prevent choking
- Low cost fabrication of modules with complicated internal geometries through chemical etching

Microprobe of α -SiC Reaction Bonded Using Ti Foil

Conditions: 1250 °C, 24 MPa, 2 hr, vacuum, 5 °C/min

Microcracking may be due to the formation of two detrimental phases:

- Phase B $Ti_5Si_3C_x - Ti_5Si_3$ if highly anisotropic in its thermal expansion where $CTE(c)/CTE(a) = 2.72$ (Schneibel et al).
- Phase E – Ti_3Al has low ductility at low temperatures. Al can be in the range of 23-35 atm % (Djanarthany et al).

Both phases can contribute to thermal stresses and microcracking during cool down.

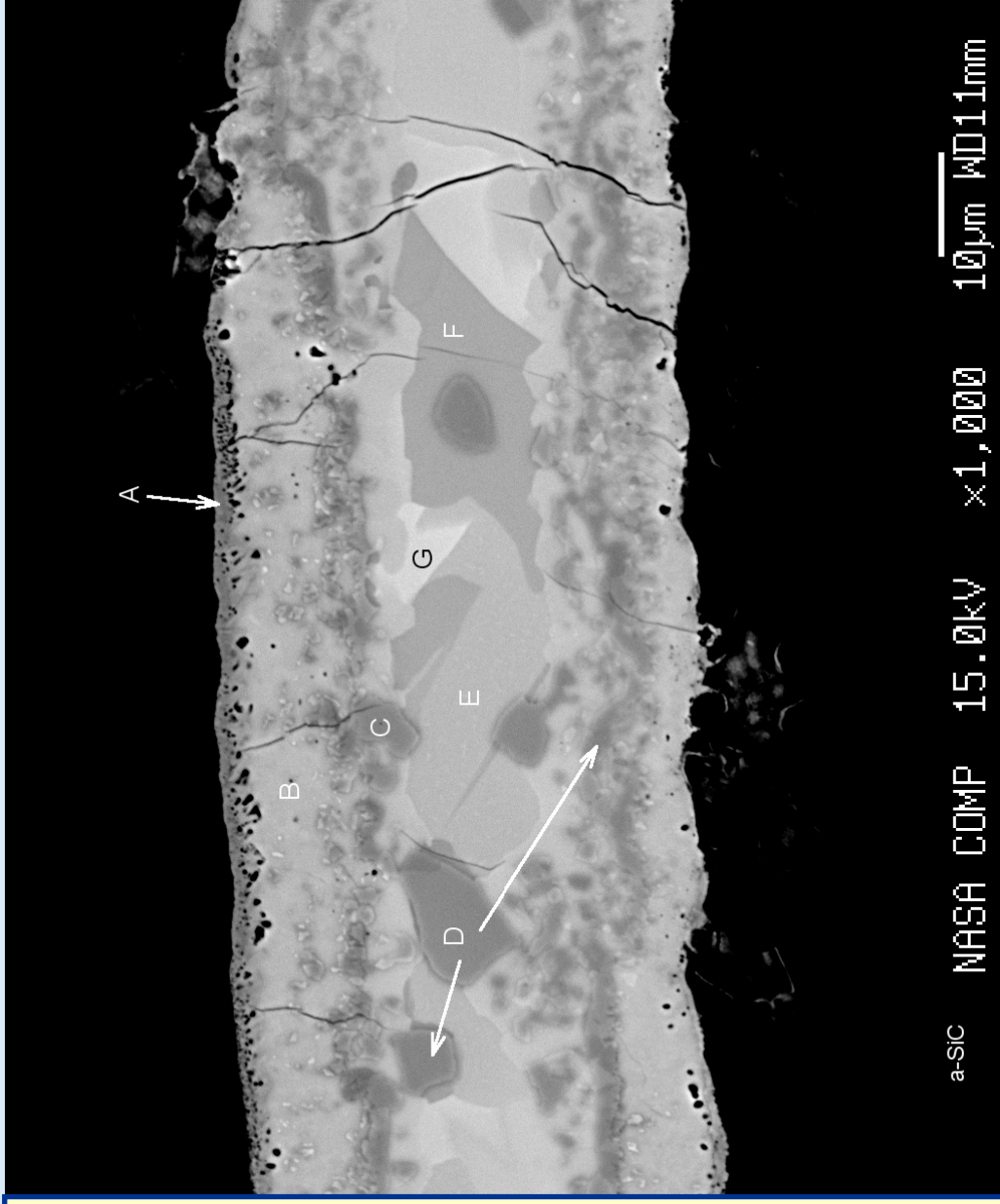

Microprobe of CVD SiC Reaction Bonded Using PVD Ti Conditions: 1250 °C, 31 MPa, 2 hr, vacuum, 5 °C/min

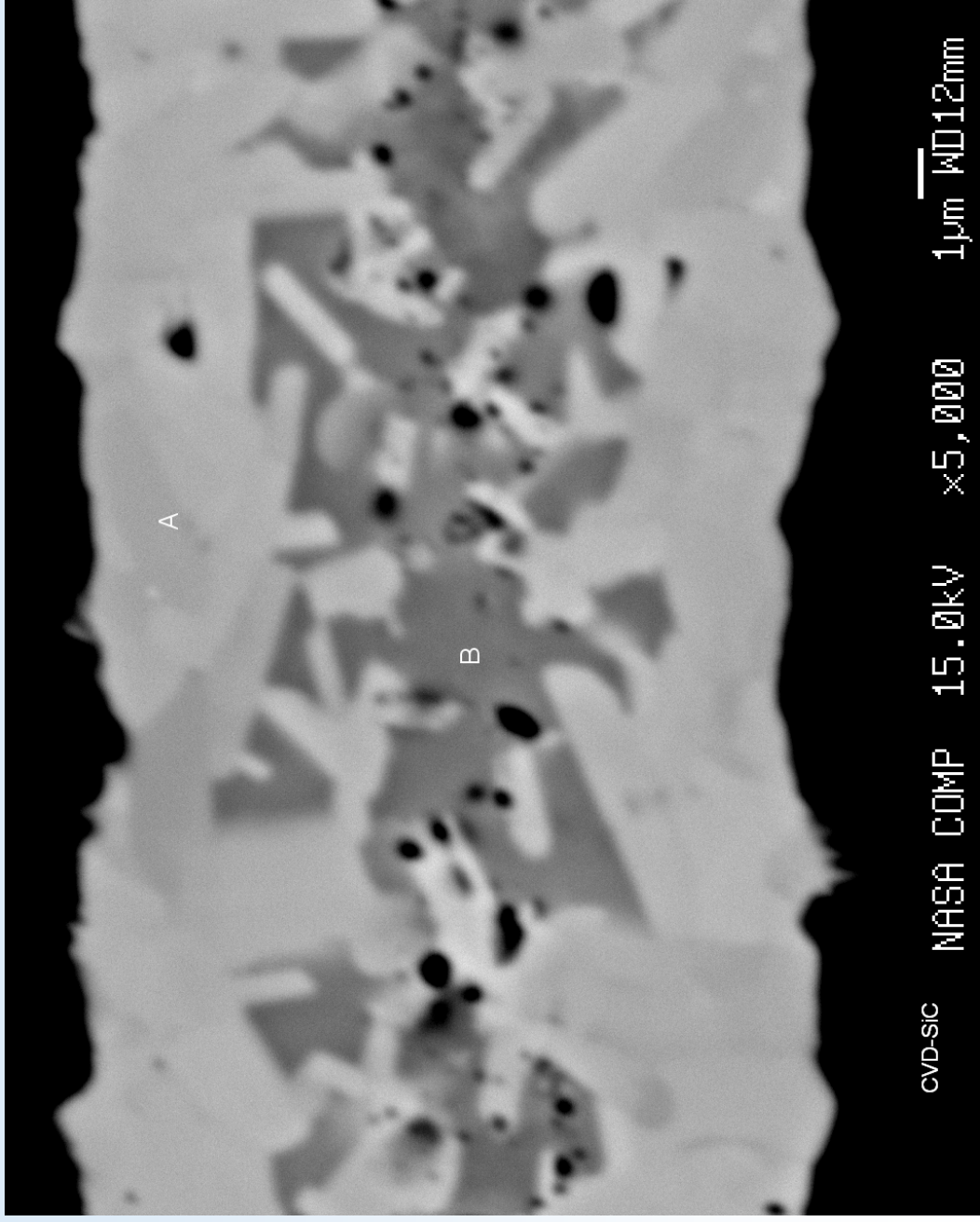

The undesirable phases of Ti_5Si_3 and Ti_3Al were not formed.

No microcracks are observed.

Identity/source of the black phase or voids still needs to be determined.

Initial Strength Tests on Diffusion Bonded CVD SiC with a PVD Ti Interlayer

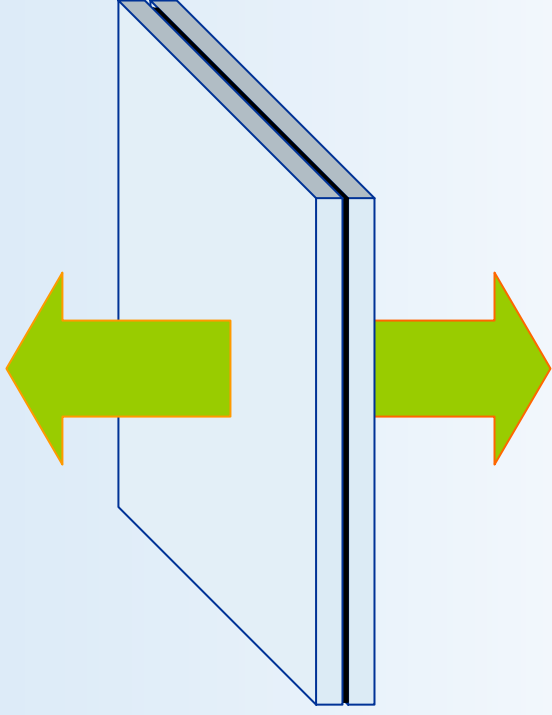

Initial pull test tensile strengths:

> 23.62 MPa (3.43 ksi)*

> 28.38 MPa (4.12 ksi)*

* failure in the adhesive

The injector application requires a strength of about 3.45-6.89 MPa (0.5 - 1.0 ksi). The new 1" sample design (partially coated disks) will allow for stresses of 62 MPa (9 ksi) to be applied (due to a large adhesive/pull area compared to the diffusion bond area).

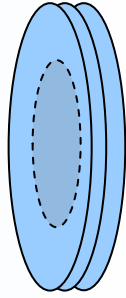

Joining of Advanced Ceramics and Composites

- *Monolithic SiC Ceramics*
- *Fiber Reinforced Composites*

Joining of Ceramic Components Using Affordable, Robust Ceramic Joining Technology (ARCJoinT)

**Apply Carbonaceous
Mixture to Joint Areas
Cure at 110-120°C for
10 to 20 minutes**



**Apply Silicon or Silicon-Alloy
(paste, tape, or slurry)
Heat at 1250-1425°C
for 10 to 15 minutes**



**Affordable and Robust
Ceramic Joints with
Tailorable Properties**

**1999 R&D 100 Award
2000 NorTech Innovation Award**



Advantages

- Joint interlayer properties are compatible with parent materials.
- Processing temperature around 1200-1450°C.
- No external pressure or high temperature tooling is required.
- Localized heating sources can be utilized.
- Adaptable to in-field installation, service, and repair.

ARCJoinT is Currently Being Used to Join and Repair a Wide Variety of Ceramic and Composite Materials

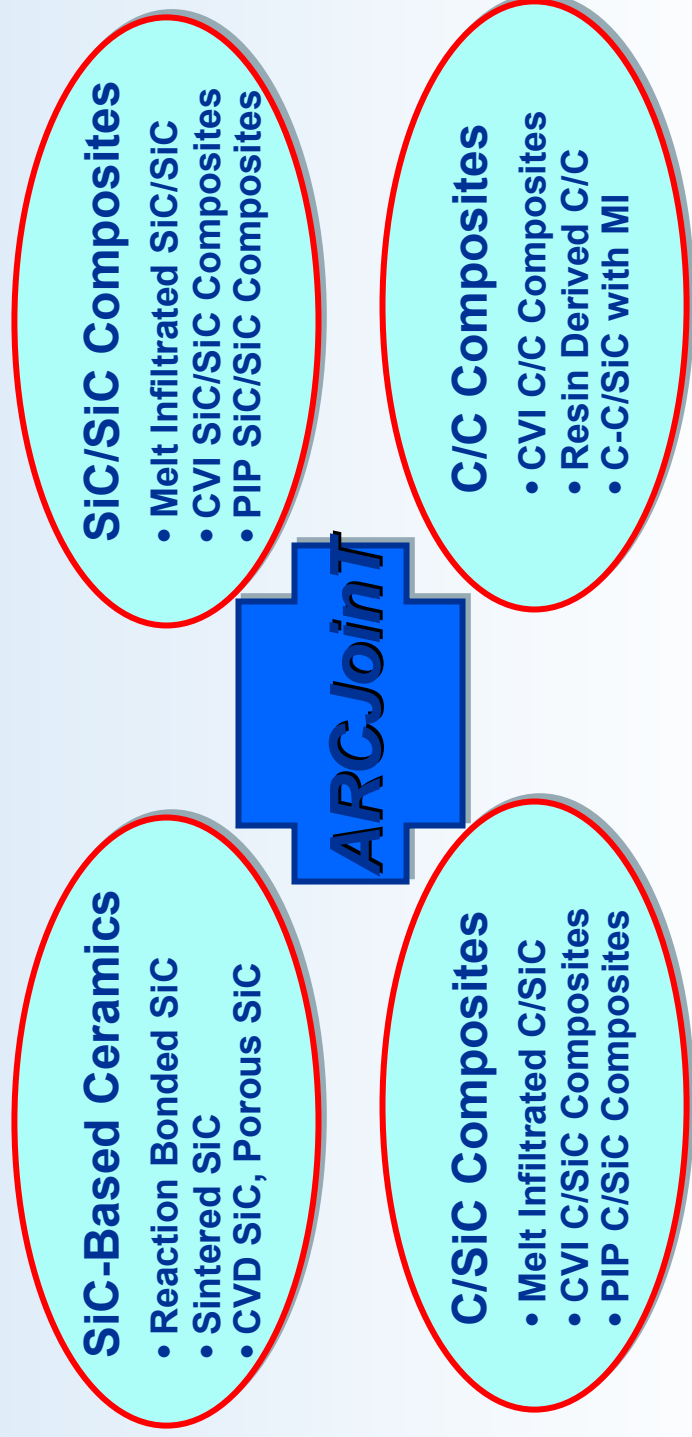

- ***Composites with Different Fiber Architectures and Shapes***
- ***Ceramics with Different Shapes and Sizes***

Technical Challenges in Design and Selection of Joints in Advanced Ceramics and Composites

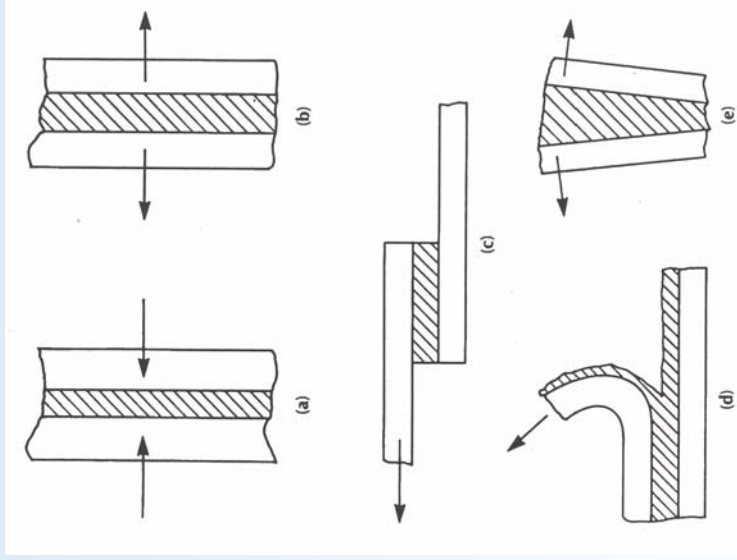

(a) Compression; (b) Tension; (c) Shear; (d) Peel; (e) Cleavage

Typical Ceramic Joints will have Combination of Stresses Under Operating Conditions

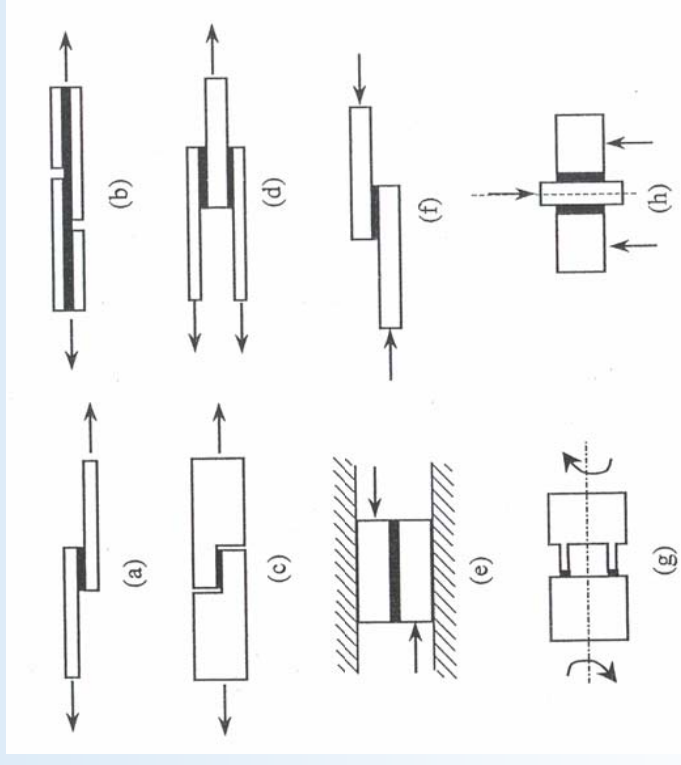

Different Types of Shear Tests

Technical Challenges in Joining of Ceramic Matrix Composites

- ***Joint Design***
 - High elastic modulus of ceramic joint materials provides significant challenges to joint design and characterization.
 - Understanding of stress state in the joints.
- ***Materials Related Issues***
 - Optimization of in-plane tensile properties of CMCs by engineering the fiber/matrix interface is accomplished at the expense of interlaminar properties. Weak interfaces complicate joint properties and performance
 - Composition and microstructure
 - Bonding and adhesion
 - Testing and data analysis
 - High elastic modulus ceramic joint materials.
- ***Life Time Testing for Specific Applications***
 - Time dependent thermomechanical properties of joints.
 - Environmental effects on joint properties.

Microstructure of As-Fabricated Joints in Monolithic SiC Ceramics

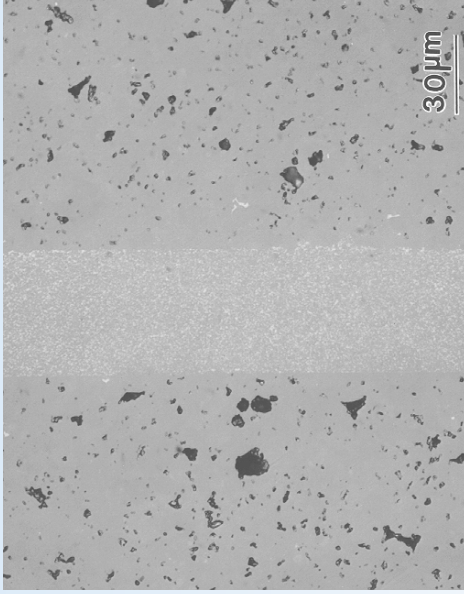

Sintered SiC (Hexoloy-SA)

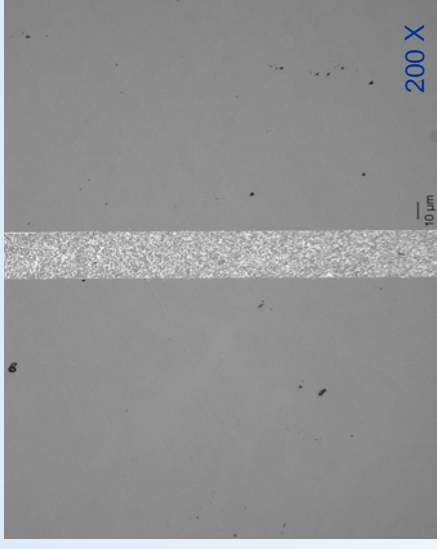

CVD-SiC

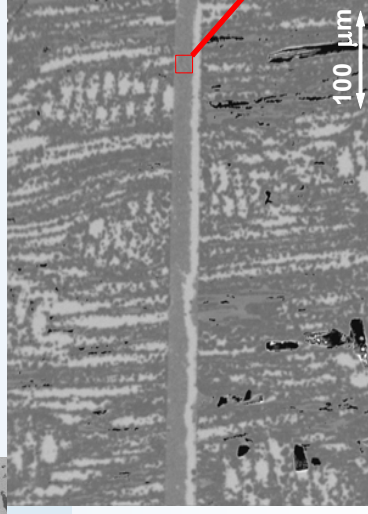

Ecoceramics
African Bubinga

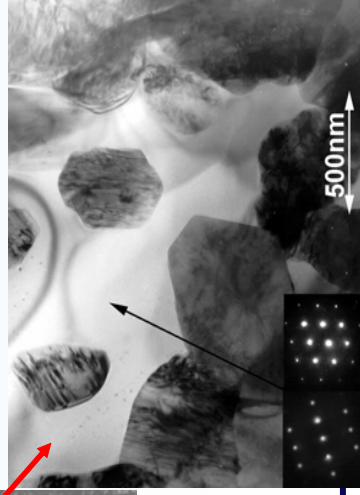

TEM Analysis of Reaction Formed Joints

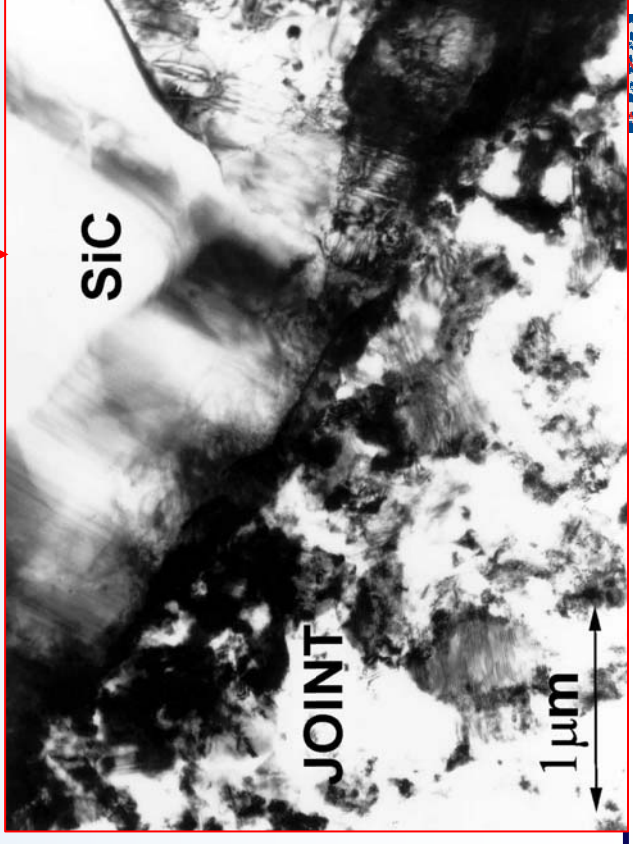
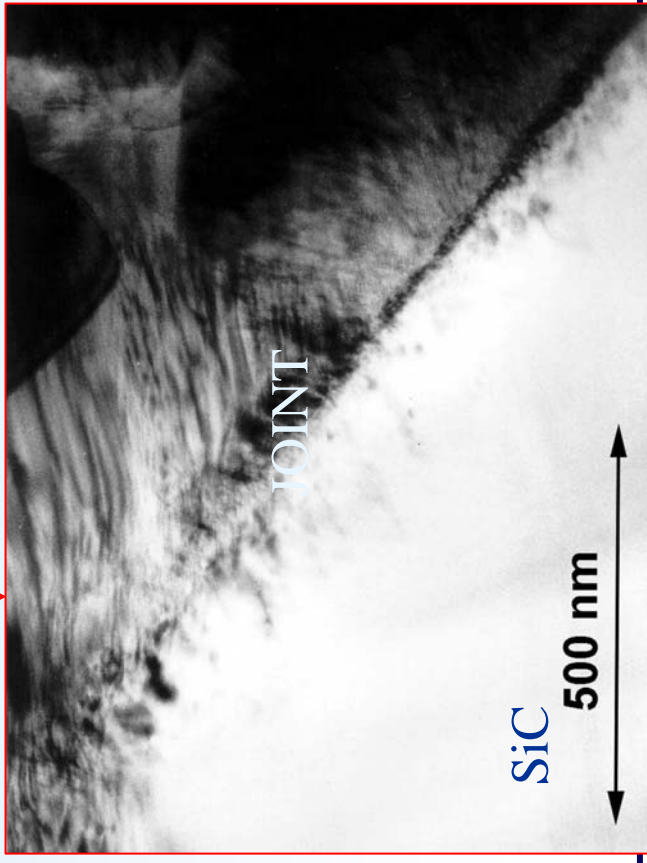
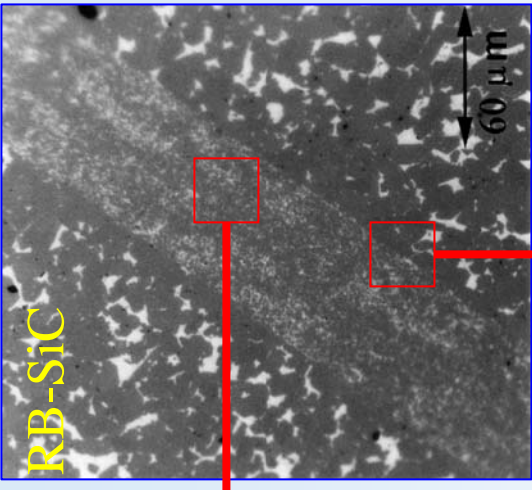
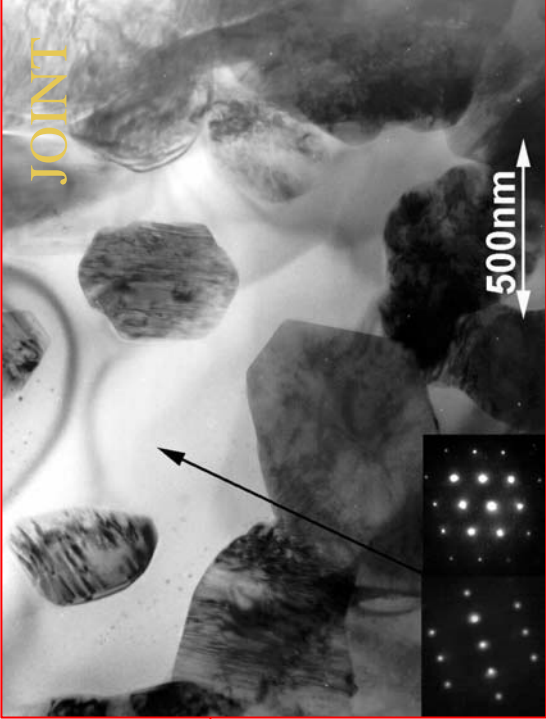
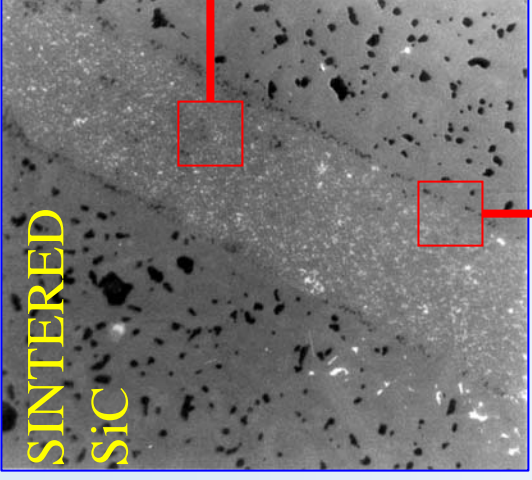

Fracture Strength Distribution of Joined SiC (Hexoloy-SA) at Different Temperatures

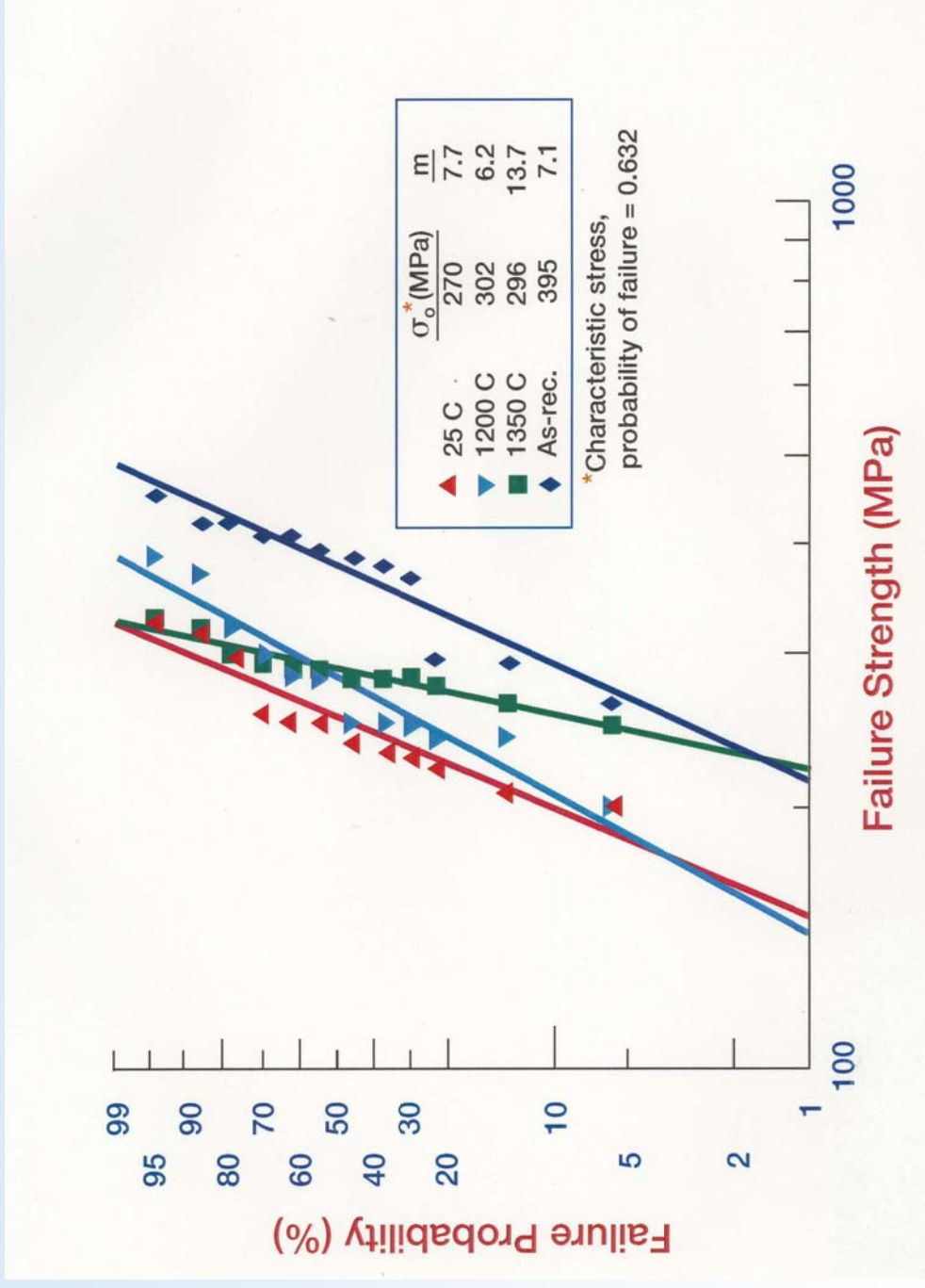

Flexural Strengths of Joined CVD SiC Ceramics

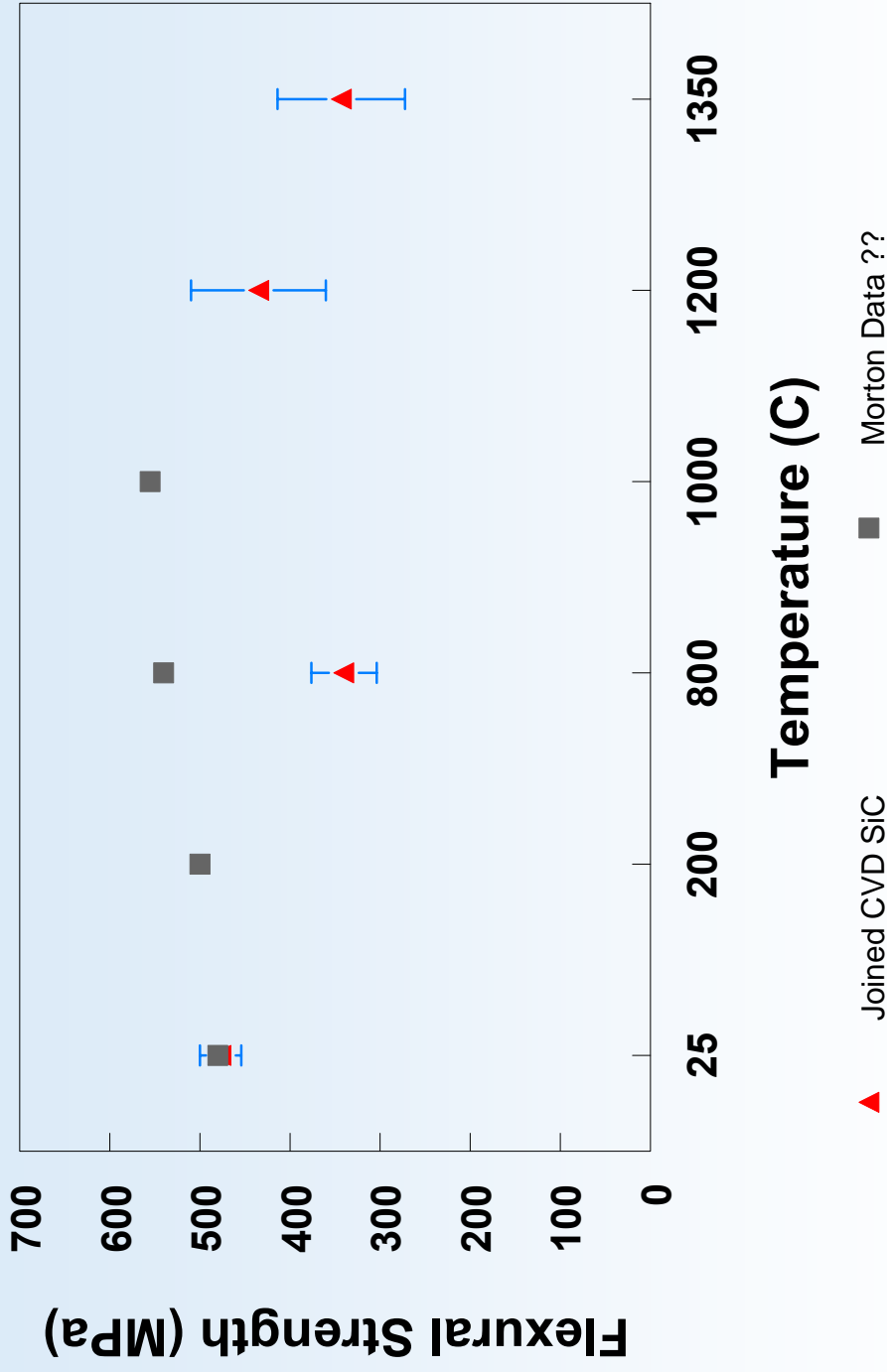

Average data for five specimens

No. of specimens unknown

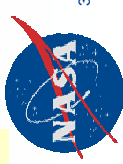

Effect of Surface Roughness on the Shear Strength of Joined CVI C/SiC Composites

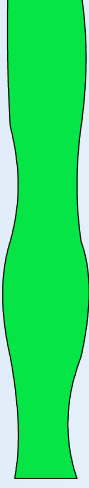

CVI C/SiC Composites

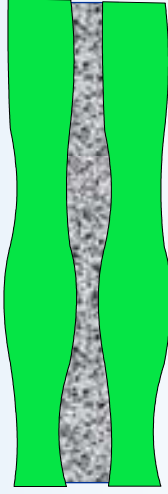

Joints with As-Fabricated Surfaces

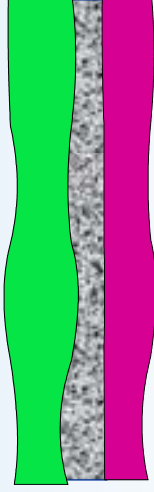

Joints with As-Fabricated/
Machined Surfaces

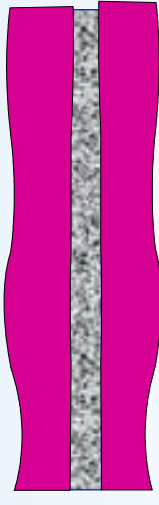

Joints with Machined Surfaces

Specimen Geometry and Test Fixture Used for Compression Double-Notched Shear Tests

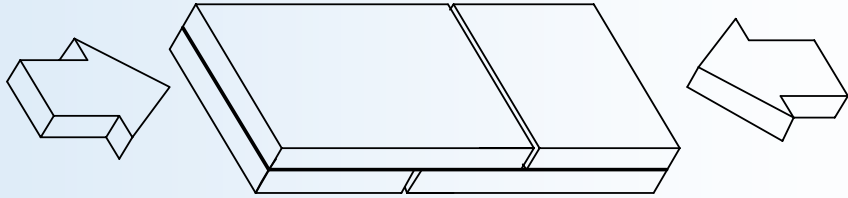

**ASTM C 1292-95a (RT)
and ASTM C 1425-99 (HT)**

Specimen Dimensions

**Specimen length (L) : 30 mm
(± 0.10 mm)**

**Distance between notches (h)
: 6 mm (± 0.10 mm)**

**Specimen width (W) : 15 mm
(± 0.10 mm)**

**Notch width (d) : 0.50 mm
(± 0.05 mm)**

**Specimen thickness (t) :
(adjustable)**

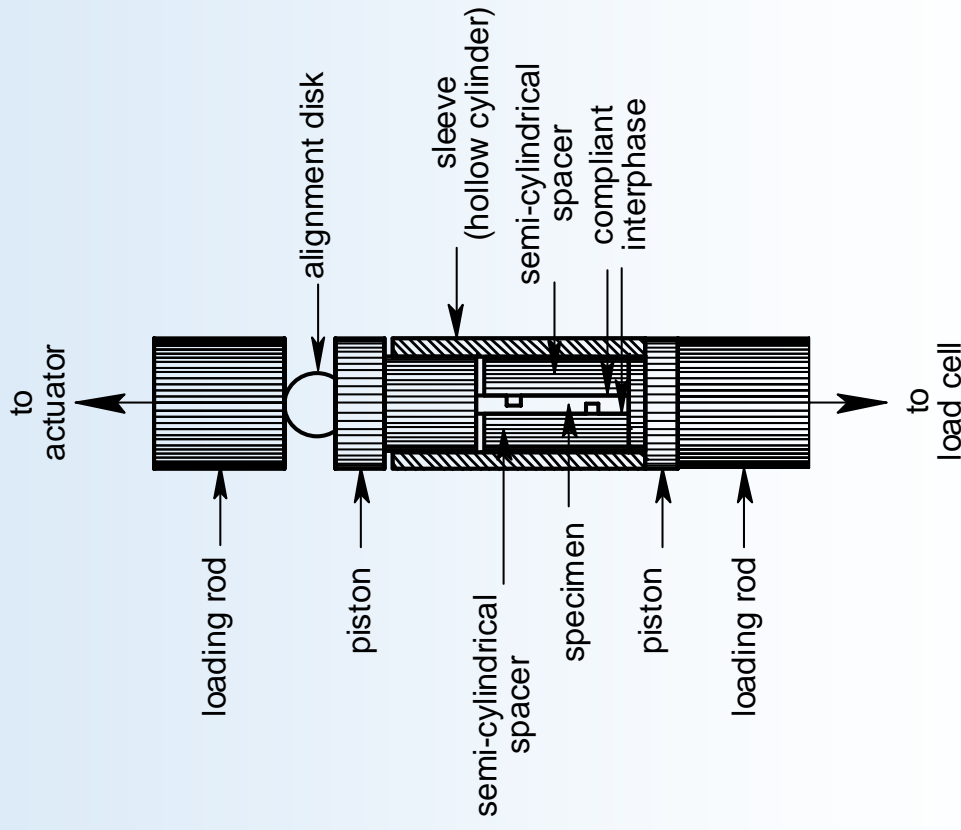

Typical Stress-Strain Behavior Obtained During the Compression Double-Notched Shear Tests

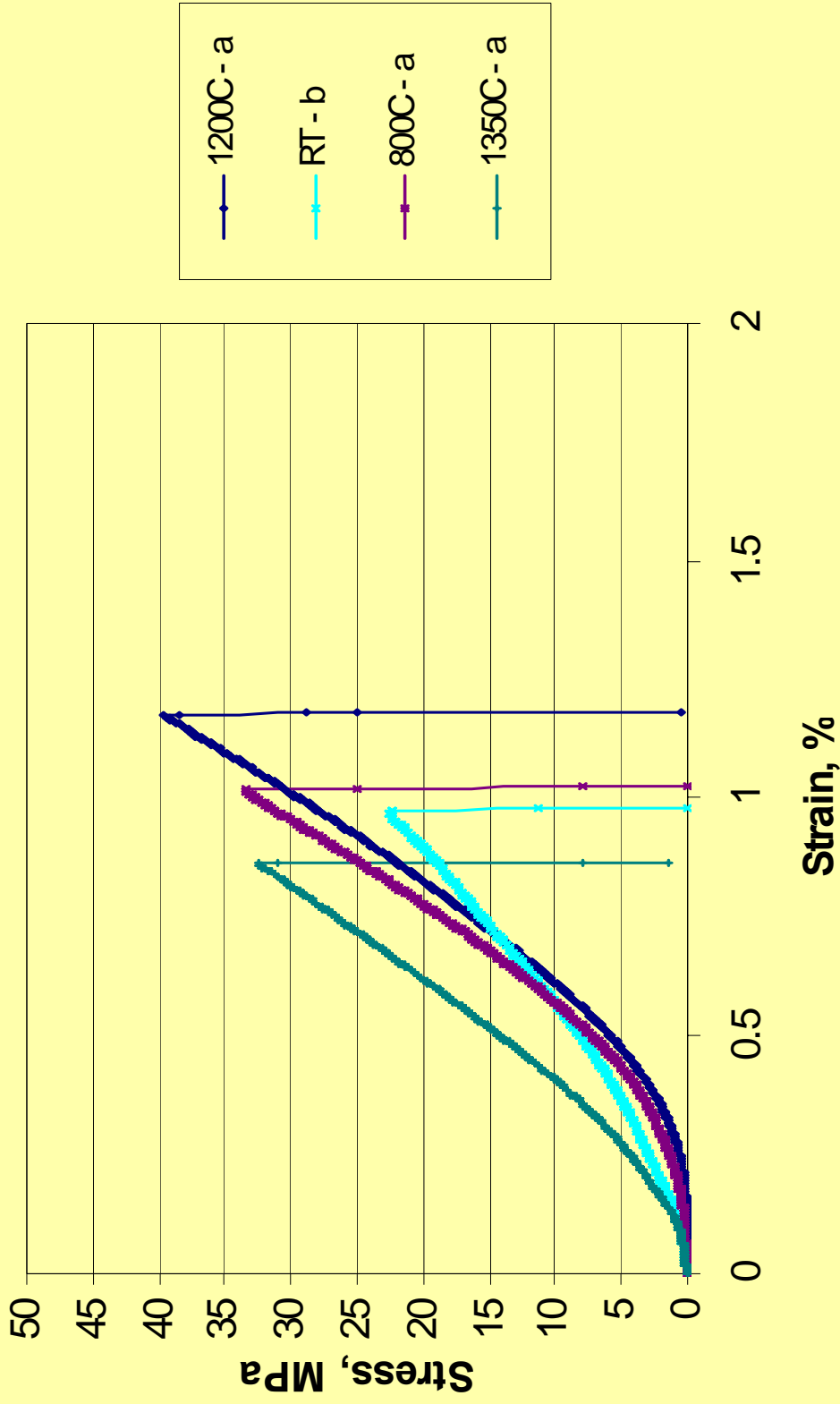

Compression Double Notch Shear Strength of Joined CVI SiC Composites at Different Temperatures

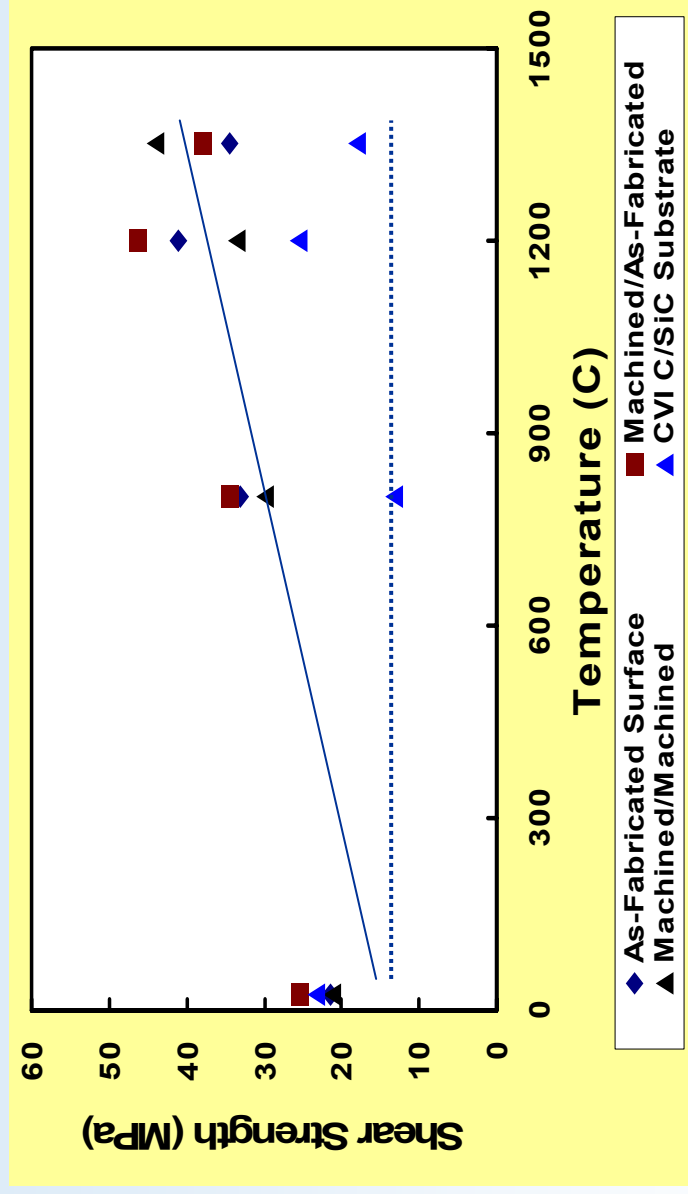

- Shear strength of joints increases with temperature and is higher than the CVI SiC composite substrate.
- No apparent influence of surface condition on the shear strength of joints.

Examples of Components Joined Using ARCJoinT



Joined SiC Tubes for Wafer Fabrication System



Carbon-Carbon Composite Valves for Race Car Engines

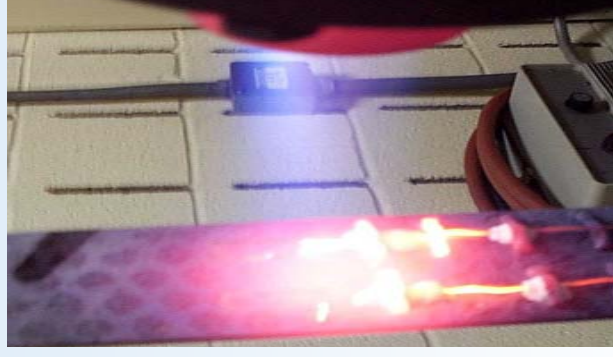

Attachment for Sensors

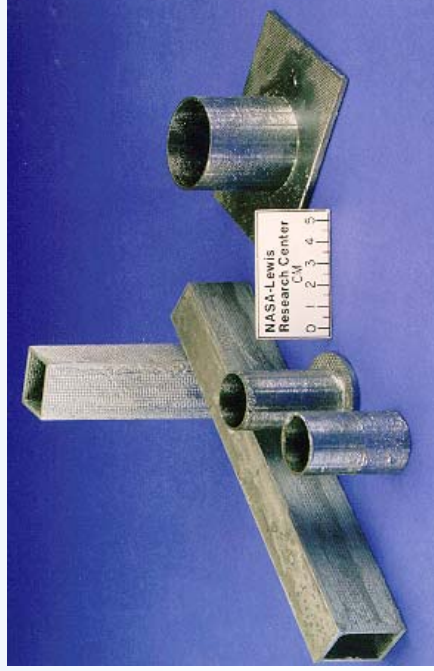

Joined C/SiC Composites



Summary and Conclusions

- Joining and assembly technologies are critically needed for the robust design and manufacturing of components.
- Braze/Solder effectiveness is dictated by several issues: wetting, spreading, bonding, and thermal mismatch.
- Thermal expansion mismatch between C-C/Braze/Titanium and interlaminar properties of C/C composites play a key role in mechanical behavior of joint.
 - *CuSil ABA paste was most successful even though not the lowest temperature braze*
 - *S-Bond Solder had best shear strengths due to low processing temperature*
- The purity control of metallic interlayer is also very critical for good joints.
- ARCJoinT process has been used to make several types of joints in SiC, C/SiC, and SiC/SiC composites. Joints in monolithic ceramics (CVD and Sintered SiC) show ~75% of the strength compared to bulk materials.
- In C/SiC composites, whether the joined surfaces are as-received (rough) or machined (smooth) has no effect on the shear strength of the joint. Furthermore, the shear strength of all joints exceeds that of the as-received C/SiC at elevated temperatures up to 1350 C.
- High elastic modulus of ceramic joints and weak interfaces in composite materials provide significant challenges to joint design and are critical to joint properties and performance.
- A combination of tensile, shear, and subcomponent testing of joints coupled with fracture mechanics based design and analysis is needed to generate useful engineering design data.