

NASA/CR-2007-214860



# Modeling and Optimization for Morphing Wing Concept Generation

*Michael D. Skillen and William A. Crossley  
Purdue University, West Lafayette, Indiana*

March 2007

## The NASA STI Program Office . . . in Profile

Since its founding, NASA has been dedicated to the advancement of aeronautics and space science. The NASA Scientific and Technical Information (STI) Program Office plays a key part in helping NASA maintain this important role.

The NASA STI Program Office is operated by Langley Research Center, the lead center for NASA's scientific and technical information. The NASA STI Program Office provides access to the NASA STI Database, the largest collection of aeronautical and space science STI in the world. The Program Office is also NASA's institutional mechanism for disseminating the results of its research and development activities. These results are published by NASA in the NASA STI Report Series, which includes the following report types:

- **TECHNICAL PUBLICATION.** Reports of completed research or a major significant phase of research that present the results of NASA programs and include extensive data or theoretical analysis. Includes compilations of significant scientific and technical data and information deemed to be of continuing reference value. NASA counterpart of peer-reviewed formal professional papers, but having less stringent limitations on manuscript length and extent of graphic presentations.
- **TECHNICAL MEMORANDUM.** Scientific and technical findings that are preliminary or of specialized interest, e.g., quick release reports, working papers, and bibliographies that contain minimal annotation. Does not contain extensive analysis.
- **CONTRACTOR REPORT.** Scientific and technical findings by NASA-sponsored contractors and grantees.

- **CONFERENCE PUBLICATION.** Collected papers from scientific and technical conferences, symposia, seminars, or other meetings sponsored or co-sponsored by NASA.
- **SPECIAL PUBLICATION.** Scientific, technical, or historical information from NASA programs, projects, and missions, often concerned with subjects having substantial public interest.
- **TECHNICAL TRANSLATION.** English-language translations of foreign scientific and technical material pertinent to NASA's mission.

Specialized services that complement the STI Program Office's diverse offerings include creating custom thesauri, building customized databases, organizing and publishing research results ... even providing videos.

For more information about the NASA STI Program Office, see the following:

- Access the NASA STI Program Home Page at <http://www.sti.nasa.gov>
- E-mail your question via the Internet to [help@sti.nasa.gov](mailto:help@sti.nasa.gov)
- Fax your question to the NASA STI Help Desk at (301) 621-0134
- Phone the NASA STI Help Desk at (301) 621-0390
- Write to:  
NASA STI Help Desk  
NASA Center for AeroSpace Information  
7115 Standard Drive  
Hanover, MD 21076-1320

NASA/CR-2007-214860



# Modeling and Optimization for Morphing Wing Concept Generation

*Michael D. Skillen and William A. Crossley  
Purdue University, West Lafayette, Indiana*

National Aeronautics and  
Space Administration

Langley Research Center  
Hampton, Virginia 23681-2199

Prepared for Langley Research Center  
under Grant NNL06AA04G

March 2007

Available from:

NASA Center for AeroSpace Information (CASI)  
7115 Standard Drive  
Hanover, MD 21076-1320  
(301) 621-0390

National Technical Information Service (NTIS)  
5285 Port Royal Road  
Springfield, VA 22161-2171  
(703) 605-6000

## Summary

This report consists of two major parts: 1) the approach to develop morphing wing weight equations, and 2) the approach to size morphing aircraft. Combined, these techniques allow the morphing aircraft to be sized with estimates of the morphing wing weight that are more credible than estimates currently available; aircraft sizing results prior to this study incorporated morphing wing weight estimates based on general heuristics for fixed-wing flaps (a comparable “morphing” component) but, in general, these results were unsubstantiated. This report will show that the method of morphing wing weight prediction does, in fact, drive the aircraft sizing code to different results and that accurate morphing wing weight estimates are essential to credible aircraft sizing results.

The first portion of this report describes a method to develop morphing wing weight equations. The basic idea behind this approach is that a morphing wing weight database is necessary to develop a parametric wing weight predictor similar to those currently used for fixed-geometry aircraft components. Design of Experiments (DOE) provides a means with which to define a database of morphing wings with various planform dimensions, extents of shape variation due to morphing, and loading conditions. For each wing prescribed in this database, representative finite element models will then be created and structurally sized using an optimization routine developed for morphing wing components. The optimized weight of each of these FEMs, along with the parameters describing the wing, will be used to determine coefficients and exponents for a basis equation. The resulting equation becomes the morphing wing weight predictor. The means by which to implement this process using idealized beam model representations and intermediate complexity finite element models will be described.

The second portion of this report describes the methods used to size a morphing aircraft; the major aircraft parameters and “optimal” wing shapes will be determined such that the aircraft gross weight is minimized for a given design mission. In this sense, the aircraft sizing process determines the basic wing dimensions and morphing capabilities necessary to most efficiently enable the aircraft design mission. The implemented technique will use the idea of a morphing wing “template” that restricts the wing shape variation during the course of the design mission to physically realizable mechanization strategies (an admissible substructure and actuation scheme capable of producing the changes in wing shape). The integration of the developed morphing wing weight equation into the template-based aircraft sizing routine will be shown to be a trivial matter in this case.

## Table of Contents

Summary.....	1
Table of Contents.....	2
Nomenclature .....	3
I. Introduction .....	3
II. Developing Finite Element Based Wing Weight Predictors .....	4
A. Design of Experiments .....	4
B. Structural Optimization Strategies .....	5
1. Simultaneous Analysis Approach.....	5
2. Simultaneous vs. Sequential Optimization Strategies .....	5
C. Finite Element Modeling.....	6
1. Structural Modeling.....	6
2. Major Structural Joints .....	7
3. Actuator Weight Prediction .....	7
D. Weight Equation Basis Functions .....	8
E. Regression Technique .....	8
F. Process Implementation .....	8
1. Beam Model Representation.....	8
2. Intermediate Complexity Model.....	8
G. Case Study – Variable Sweep / Variable Chord Concept.....	9
1. Definition of the Wing Geometry Parameters, {X}.....	9
2. DOE Parameters and Their Bounds.....	9
3. Definition of the Wing Configurations and Structural Layouts.....	9
4. DOE Results .....	10
5. Regression Results.....	10
III. Preliminary Morphing Aircraft Sizing .....	11
A. Overview .....	11
B. Problem Statement .....	11
C. Independent Variable Sets.....	12
1. “Photomorphing” Approach.....	12
2. Template-based Approach.....	12
D. Aircraft Weight Prediction .....	14
1. Wing Weight Prediction via “Photomorphing” .....	14
2. Wing Weight Prediction via Template-based Morphing Wing Weight Predictor .....	14
E. The Optimization Problem .....	14
F. Case Study.....	14
1. Mission Definition.....	14
2. Definition of the Wing Template.....	15
3. Sizing Results .....	15
IV. Conclusions and Suggested Future Efforts.....	17
Acknowledgments .....	18
References .....	18
Appendices .....	20
A. Examples of Template-Based Morphing FEM’s.....	20
B. Overall Process Implementation for the Beam Model Representation.....	21
C. Overall Process Implementation for the Intermediate Complexity Model .....	22

## Nomenclature

$AR$	=	Wing aspect ratio
$N$	=	Number of DOE trials
$S$	=	Wing area
$T/W$	=	Aircraft thrust to weight ratio
$W/S$	=	Wing loading
$m$	=	Number of mission legs in the aircraft design mission
$n$	=	Number of DOE system parameters
$n_z$	=	Maximum vertical load factor
$t/c$	=	Wing thickness to chord ratio
$\{a\}$	=	Set of fitting parameters in the basis equation
$\{x\}$	=	Structural design variables
$\{X\}$	=	Set of morphing wing parameters
$\{X_{a.c.}\}$	=	Set of aircraft sizing design variables
$\Delta b$	=	Change in wing span
$\Delta c$	=	Change in wing chord
$\Delta \Lambda$	=	Change in quarter-chord wing sweep
$\lambda$	=	Wing taper
$\Lambda$	=	Quarter-chord wing sweep

## I. Introduction

MORPHING aircraft, as defined in this report, are aircraft utilizing wings that have the capability to drastically change planform shape during flight – perhaps a 200% change in aspect ratio, 50% change in wing area, and a 20 degree change in wing sweep.<sup>1</sup> This type of design might be incorporated to enhance various operational capabilities of the aircraft, reduce the aircraft’s required takeoff gross weight, and/or enable an aircraft to fly a design mission that a fixed-wing aircraft could not.. Most recently, two flight-traceable morphing wing concepts were developed through Phase II of DARPA’s Morphing Aircraft Structures (MAS) program.<sup>2</sup> The first, a “folding wing” concept, was developed by Lockheed Martin and enables variations of span length, aspect ratio, and effective sweep angle. The second, a variable sweep / variable root chord concept, was developed by NextGen Aeronautics and enables direct variations in root chord length and sweep angle; indirectly varying the planform area and aspect ratio. Both of these are illustrated in the following figure.

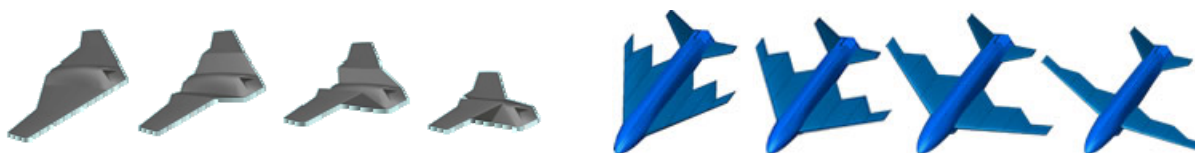

**Figure 1 Recently Developed Morphing Wing Concepts (Left – Lockheed Martin’s Folding Wing Concept, Right – NextGen Aeronautics Variable Sweep / Variable Root Chord Concept)**

While Phase II of the MAS program concentrated on development and testing of scaled wind tunnel models to determine system feasibility in flight equivalent environments (wind tunnel experiments at the TDT at NASA, Langley), Phase III will pursue the development of these concepts as flight demonstrational vehicles.<sup>3</sup>

Clearly, application of morphing wing technologies will require the concurrent development of design and optimization strategies at the aircraft level to expedite overall development of these systems. Of major importance is the development of a robust morphing aircraft sizing code to be used during conceptual design tasks. Such a tool would enable studies of the operational benefits at the aircraft system level and provide a methodological basis for future morphing aircraft sizing codes. The major drawback of such an effort, however, is that accurate weight predictions are required for all major components, including the morphing wing. Little information is currently available to substantiate such a wing weight prediction and thus, the sizing results would be unfounded. However, this report illustrates various means to implement a robust morphing aircraft sizing code (Part III) and develop morphing wing weight predictions that are more credible than currently available (Part II). The entire process is then demonstrated using a variable sweep / variable chord concept similar to the NextGen concept.

## II. Developing Finite Element Based Wing Weight Predictors

The most common approach to developing fixed-wing weight predictors is centered on the idea that a large database of wing weights, their associated geometry, and maximum loading conditions already exists through fielded aircraft. By selecting a subset of these data with common features (e.g. wings having aspect ratio and taper within some range), various analytical methods can be employed to predict flight-ready wing weight as a function of the wing parameters (e.g. AR, W/S,  $n_z$ , t/c, etc.). Reference 4 provides an early example of this technique (circa 1968) in which fighter aircraft wing weight predictors were developed from a small set of aircraft (~15) using a least squares regression approach and basis functions similar to those developed by F.R. Shanley<sup>5</sup> in 1960.

Direct application of the above approach is not possible for morphing wing components because an adequate set of fielded aircraft data is nonexistent. However, the approach used here is to develop a surrogate wing weight database, and proceed with the equation development in the usual way. This sort of approach was successfully used in the design of a high speed civil transport aircraft (fixed-wing).<sup>6</sup> Using Design of Experiments (DOE) methods to define a set of morphing wings with various shapes, representative finite element models are developed for each wing in the database and then sized to give a corresponding weight estimate. These data are then “best fit” to an appropriate basis equation using a least squares regression technique resulting in the morphing wing weight equation. The various aspects of this process are described in more detail in the following sections.

### A. Design of Experiments

In this research, a morphing wing will be defined by a number of parameters,  $\{X\}$ , that include the basis wing geometry (also referred to as the reference wing geometry), extent of morphing capabilities, and parameters describing the structural loading conditions. More specifically,  $\{X\}$  is defined by the following relation:

$$\{X\} \in \{AR, S, t/c, \lambda, \Lambda\} \cup \{\Delta b, \Delta c, \Delta \Lambda\} \cup \{W/S, n_z\} \quad (1)$$

where the sets have been separated by category. Although  $\{X\}$  must contain the basis wing geometry and loading conditions, the set of morphing parameters contained in  $\{X\}$  depends on the particular morphing wing concept being implemented. For example, a conventional variable sweep wing would be represented by the morphing parameter set  $\{\Delta \Lambda\}$  because the morphing mechanism directly varies sweep. Note that although a variation in sweep changes the chord distribution and span length measured with respect to the aircraft body axis,  $\Delta b$  and  $\Delta c$  are not included in the set because the morphing mechanism has not physically changed the span and chord lengths measured in the wing’s reference frame.

The Design of Experiments technique enables the mapping of a continuous design space to a finite set of points within the design space. Various Designs of Experiments exist, and the particular type used governs the number of points in the mapped set and their distribution / position within the design space. Table 1 illustrates three possible DOE types and the number of “experiments” (points within the mapped design space) as a function of the number of independent parameters to be varied (the number of dimensions making up the design space). For example, if a morphing wing was described by a set of 7 parameters, a full factorial design would prescribe 2187 wing shapes within the bounded design space at which to evaluate the wing weight, while a face-centered central composite design would prescribe 77. The table entry for the saturated D-optimal design shows two values for the number of prescribed experiments. This results from the fact that the number of design points specified is equal to the number of unknowns in the basis equation used during the regression. As will be shown in Section D, two such basis equations are considered and have different numbers of unknowns. For any of these table entries, the left number is representative of the “conventional” basis equation, while the right represents the full quadratic response surface.

DOE Type	Number of Parameters			
	6	7	8	n
Full Factorial Design	729	2187	6561	3 <sup>n</sup>
Face-Centered CCD	77	143	273	2 <sup>n</sup> +2n+1
Saturated D-optimal Design	7/28	8/36	9/45	(n+1) / (n+1)(n+2)/2

Table 1 Number of Experiments for Various DOE Types and Number of System Variables

Typically, the more data available from the design space will reduce the uncertainty of wing weight variations within the design space, but will clearly increase the time needed to develop the weight database. Therefore, the goal of selecting a DOE type is to maximize the quality of the regression (accurately determine the wing weight trends with respect to variation of parameters) while minimizing the number of points used to formulate the weight



equation. Unfortunately, the quality of regression typically can not be predicted *a priori* and the convergence of the weight equation must be determined through trial and error. However, in Reference 7, this author finds that a saturated D-optimal design set gives a good representation of trends within the design space, while a face-centered central composite design yields equations with coefficients of correlation on the order of 0.98. Note that this heuristic was based on the “conventional” basis equation (see Section D) using beam model representations of the morphing wings.

## B. Structural Optimization Strategies

### 1. Simultaneous Analysis Approach

Although methods to carry out the structural sizing process are outlined in greater detail in previous work (see Reference 8), the simultaneous analysis approach has been used in this investigation and will be revisited here for completeness. The aircraft is assumed to operate with the morphing wing in distinct configurations (shapes) for major portions of the design mission. For example, the wing might operate in a high sweep configuration during a dash leg of the design mission. In this approach, the structural sizing routine follows a conventional strategy for a fixed-wing structure in which a set of design load conditions (e.g. symmetric and / or asymmetric maneuvering conditions, gust loads, impact loads, etc.) are considered simultaneously during the sizing process and an “optimal” structural weight is determined such that all imposed design constraints are satisfied. In the case of a morphing wing, the critical load cases which tend to induce maximum constraint conditions must be considered simultaneously for all wing configurations to determine the optimal (or nearly optimal) load paths. Figure 2

illustrates this methodology with greater detail. Here,  $\{x\}$  represents the structural design variables (i.e. spar thicknesses, spar cap areas, number of layers in a composite laminate, and/or skin thicknesses) and  $\{g\}_i$  represents the design constraints (i.e. maximum stress, buckling, maximum deflections, etc.) for each wing configuration  $i$ . This type of sizing allows for meaningful aeroelastic constraints to be imposed, such as flutter tendencies, which might be difficult to enforce in other structural sizing approaches; see, for example, the “aggregate” sizing approach in Reference 8.

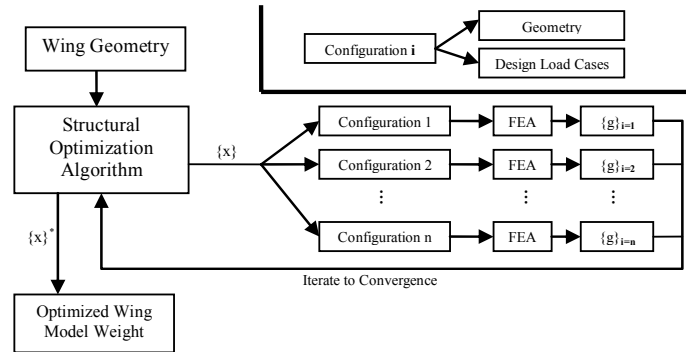

**Figure 2. The Simultaneous Analysis Sizing Approach**

### 2. Simultaneous vs. Sequential Optimization Strategies

Although the simultaneous analysis structural sizing approach is robust and follows a traditional structural sizing approach, its implementation is not readily implemented with common FEA toolsets. A secondary strategy, as presented by Lockheed Martin, is to size the wing using a sequential approach.<sup>9</sup> In this case, the wing is sized subject to a set of load cases in a load dominant configuration using a common FEA/optimization environment. The sized structural dimensions are then used as lower design variable bounds in subsequent structural optimizations with the wing in non-dominant load configurations. In the case of the Lockheed morphing wing design, the idea seems intuitively clear because the morphing is relatively simple (having only two configurations) and the substructure is fixed; the problem is simple enough to rationalize the use of the sequential optimization. However, in a more complicated structure – one which has a spatially variant substructure – with multiple configurations and load conditions, it is possible for a non-dominant load configuration to drive an optimal load path due to the arrangement of the substructure. In fact, for a simple morphing wing model, this author finds that the sequential-like optimization approach tends to over-predict the structural weight by an average of 13.5% when this sort of situation occurs.<sup>7</sup>

### C. Finite Element Modeling

The level of detail in the finite element model (FEM) representation of the morphing wing will play a pivotal roll in developing accurate weight predictors. Two FEMs are considered here: 1) a simplified beam model representing a low fidelity model and 2) an intermediate complexity model. The beam model representation allows rapid development and validation of the techniques (optimization and regression) needed to create the weight equation, can quickly perform trade studies for a given morphing wing concept, and provides a basis for comparison with more complex models. The intermediate complexity FEM will more accurately model the wing's substructure, provide a more accurate prediction of the fully designed wing weight (leading to a more reliable weight predictor), and indicate the system aspects that are most sensitive to modeling fidelity when compared to the beam model representations.

#### 1. Structural Modeling

##### a) Beam Model Representation

The beam model representation of the morphing wing provides a means to represent and size for the required bending material of the wing; this accounts for a majority of the weight when considering a fixed-wing structure<sup>5</sup>. To approximate the morphing wing structure, a beam is defined along the quarter-chord line of the wing in its reference configuration (previously referred to as the "basis" geometry). This beam is discretized into a number of segments such that the taper of the wing can be accounted for; the thickness of any segment is the average of the wing thickness at the element's endpoints. Each discretized segment of the beam is treated as a beam element in the FEM. The cross-section of each element is rectangular with the height specified by the wing thickness and the width being a design variable during the structural optimization routine.

The quarter-chord beam is defined in every model. However, this might not be sufficient to accurately describe the envisioned morphing mechanism. For example, a secondary beam might be modeled to provide a mechanical linkage to move and support the main beam. These secondary beam components are also modeled, but their geometry and discretization are dependent on the specific wing concept being implemented; References 7, 8, and 10 provide several examples of this.

Aerodynamic loads are predicted for a symmetric pull-up maneuver with specified design load factor (the design load factor is defined as the limit or operational load factor multiplied by the safety factor of 1.5) via the vortex lattice method (VLM) presented in Ref. 11. For any given element making up the main beam, the resultant vertical load predicted over the portion of the wing span bounded by the element's span domain is reduced to equivalent nodal loads at the element's endpoints; these loads are applied to the element neglecting the angle of attack of the wing (no horizontal loads are applied to the element). Furthermore, because this simple structural model does not accurately account for a real wing's torsional stiffness, chordwise pressure variations and the resulting structural torsion loads are neglected.

##### b) Intermediate Complexity Model – Morphing Wing Templates

The intermediate complexity models introduce a more detailed representation of the wing's substructure by modeling a box-beam or shell type structure capable of spatial rearrangement to facilitate morphing. In this case, the model and subsequent analyses are not as restricted as in the beam model case. For example, the critical load set is not restricted to the single symmetric load case, but can include a complete set of symmetric and antisymmetric maneuvers. Furthermore, because the model now more accurately reflects the true structure of a morphing wing, the sized structure should give a better representation of the morphing wing's true weight relative to the representative beam model; provided that the main weight drivers of the wing have been accounted for in the FEM.

Development of an intermediate complexity model (ICM) currently revolves around the idea of a morphing wing "template". In the most basic sense, a wing template defines a structural mechanization strategy that enables specific shape changing capabilities of the wing. For example, the variable sweep wing found on the F-14 could be referred to as a rigid-body sweep template. This template would describe a fixed inboard wing structure, a pivot joint, and the variable sweep outboard structure. The driving idea behind this "template"-based approach will become apparent in Section III when morphing aircraft sizing strategies are discussed.

Development of an ICM is currently facilitated using a series of Matlab-based scripts. The overall process flow is illustrated in the following figure:

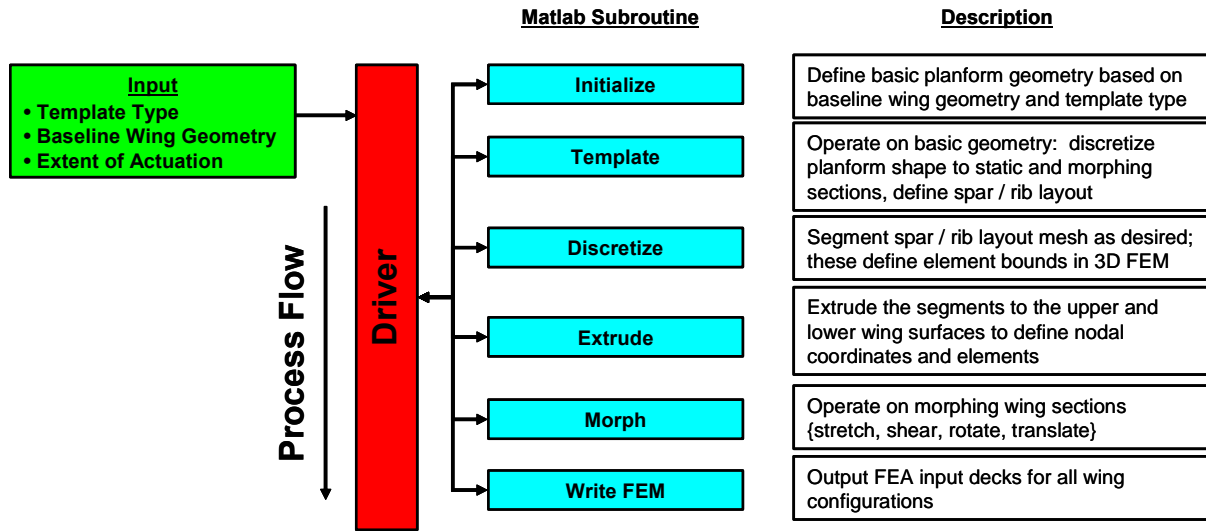
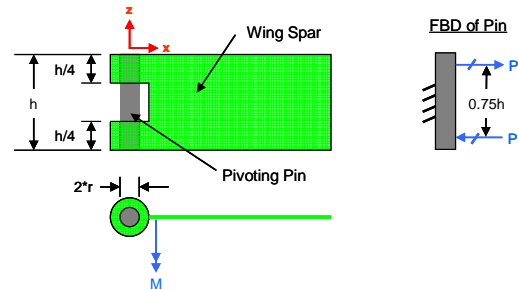

**Figure 3 Process Flow for the Development of a Template-based FEM**

The overall process requires only the definition of the morphing wing template and the discretization scheme while the other routines are fully autonomous. Also note that this scheme enables the rapid development of a morphing wing FEM as a function of some baseline wing geometry and the extent of actuation. This is important because the DOE task requires the rapid evaluation of many wings of varying sizes and morphing capabilities; a nontrivial task if one were to manually develop each model. Currently, several intermediate-complexity FEMs have been developed with various templates, but have not yet been implemented in a structural sizing process. Appendix A illustrates several examples of these.

## 2. Major Structural Joints

An important aspect of the morphing wing is that rearrangement of the substructure will require structural joints to facilitate the overall shape change. For example, the variable sweep capabilities of the F-14 require the use of a substantial pivot pin to connect the wing and fuselage structures. In this work, all pivot joints are idealized to the model illustrated in Figure 4. The design task is then limited to preventing failure due to shear in the pivot pin and the sized pin will represent the entirety of the pivot joint weight. The pin is assumed to be a solid cylinder (grey in the figure) made of Aluminum 2024-T6. The bending loads from the outboard wing section (green) are reduced to a force couple with magnitude  $P$  and moment arm  $3h/4$ . Here,  $h$  is specified by the thickness of the wing at the pivot joint. The pin diameter is then sized to prevent plastic deformation due to the maximum shear stresses on the circular cross-section. Reference 7 provides a more detailed representation of this model.



**Figure 4 Structural Pin Model**

## 3. Actuator Weight Prediction

A further important aspect of a morphing wing is the actuating mechanism that physically rearranges the wing structure. Currently, this mechanism is represented by an idealized hydraulic actuator modeled as a simple pressure vessel (the cylinder) and a solid circular column (the ram). The actuator loads are determined by adding the effects of the loads required to rearrange the aerodynamically loaded structure from one configuration to another (which is

related to changes in structural strain energy), and the loads required to overcome friction induced by moving structural components (e.g. rotation of the loaded pivot joint). These loads are then used to size the ram subject to strength and buckling constraints while the cylinder is sized subject to strength constraints using a nominal fluid pressure value. Further details regarding the modeling of these mechanisms can be found in the Appendix of Reference 7, with various case studies presented in Reference 8.

#### D. Weight Equation Basis Functions

The basis function is a generic equation form with unknown parameters that must be “best fit” to some given data set. In this work, two such basis functions will be considered when formulating the wing weight equation: The full quadratic polynomial and the conventional equation form (a product of terms raised to unknown constant powers). Table 2 illustrates both of these equations.

Equation Type	Functional Form	Number of Unknowns
<b>Full Quadratic Equation Form</b>	$W_{\text{wing}}(\{X_{1:n}\}) = a_0 + \sum_{i=1}^n a_i X_i + \sum_{i=1}^n \sum_{j=i}^n a_{ij} X_i X_j$	$\frac{(n+1)(n+2)}{2}$
<b>Conventional Wing Weight Equation Form</b>	$W_{\text{wing}}(\{X_{1:n}\}) = a_0 \prod_{i=1}^n X_i^{a_i}$	$(n+1)$

**Table 2. Functional Forms of the Wing Weight Basis Equations**

Here,  $X_i$  represents one of the  $n$  system parameters within the DOE set,  $\{X\}$ , and  $a_i$  are the unknown constants that must be fit to the data set. The conventional equation form arises from an analytical development of the wing’s bending material weight as a function of the DOE parameters,  $\{X\}$  (See Reference 7, Appendix B). This author has found that the full quadratic equation form does not accurately capture / reflect the trends within the design space and leads to a poor correlation when fit to the known data (regardless of the number of trials in the DOE). On the contrary, the conventional equation form tends to adequately model the weight trends, even for a saturated DOE trial set, and is the suggested basis equation for this type of application.

#### E. Regression Technique

A least squares regression is used to fit the data to the basis function. More specifically, given values for the fitting parameters,  $\{a\}$ , the approximated wing weight for each wing shape,  $\{X\}_i$ , from the DOE database is evaluated using the wing weight predictor. The difference between the actual wing weight from the FEA optimization and the approximated weight from the wing weight equation is calculated and squared; this is referred to as the squared error. The squared error is calculated for each wing in the DOE database and then summed to give the total error, or equivalently, the sum of squares. The optimal values for  $\{a\}$  are those which minimize the sum of squares and thus “best fits” the data to the basis equation.

#### F. Process Implementation

##### 1. Beam Model Representation

The beam model representation was the first considered by this author. In order to expedite development of the aforementioned techniques and quickly perform various trade studies, the entire process was implemented in a common environment. In this case, all tools were developed, integrated, and executed within Matlab<sup>12</sup>, including the FEA code. The entire process layout is illustrated in Appendix B of this document.

##### 2. Intermediate Complexity Model

The intermediate complexity model requires the use of a more advanced FEA environment like ASTROS<sup>13</sup> or NASTRAN<sup>14</sup>. Therefore, the overall process is more complex – requiring the integration of potentially multiple software environments (DOE, FEA, optimization, and regression toolsets) – yet more realistic to implementation outside the academic environment. Currently, iSIGHT<sup>15</sup> integrates the various process components necessary to

implement the “simultaneous analysis” structural optimization routine. This program implicitly provides a means to integrate various toolsets by: Controlling the main design variables of the problem (e.g. evaluating a DOE trial set or carrying out an optimization task), outsourcing tasks to other software packages, and autonomously handling the file I/O between itself and the various programs. In essence, this program automates trade studies and portions of the design cycle. Appendix C illustrates the overall process flow for this model.

**G. Case Study – Variable Sweep / Variable Chord Concept**

The following section will briefly describe a case study in which a wing weight equation is developed for a concept similar to NextGen Aeronautics morphing wing concept. References 7 and 8 should be consulted for further modeling details as this study will parallel those found in the references. Any differences will be clearly defined and the resulting equation will be utilized in the aircraft sizing case study of Part III of this report.

*1. Definition of the Wing Geometry Parameters, {X}*

The variable span / variable chord wing concept is characterized by the following parameter set:

$$\{X\} \in \{AR, S, t/c, \lambda, \Lambda\} \cup \{\Delta c_{root}, \Delta\Lambda\} \cup \{W/S\} \tag{2}$$

where the variable  $n_z$  is set to a limit load factor of 1.5 for all wing configurations to reduce the number of DOE parameters.

*2. DOE Parameters and Their Bounds*

Because seven parameters are being used to describe this wing concept, 273 DOE experiments will be required to implement the FC-CCD set (see Table 1). The variable bounds in the DOE set are defined as:

Parameter	Bounds			Unit
	Lower	Nominal	Upper	
AR	5	10	15	[]
S	200	300	400	[ft^2]
t/c	0.06	0.09	0.12	[]
$\lambda$	0.3	0.4	0.5	[]
$\Lambda$	5	15	25	[deg]
$\Delta c_{root}$	0.5	0.7	0.9	[]
$\Delta\Lambda$	5	17.5	30	[deg]
W/S	50	100	150	[lb/ft^2]

**Table 3 DOE Parameters and Their Bounds**

*3. Definition of the Wing Configurations and Structural Layouts*

Figure 5 illustrates the half-span planform geometry (red) and structural elements (blue) in this model using the nominal variable bounds defined in Table 3. Four distinct configurations are defined and are intuitively associated with particular flight regimes as indicated by the plot titles. Also note that the forward spar (beam along the quarter-chord line) is discretized using 5 elements while the aft spar (beam controlling the position of the forward spar) is modeled using a single element. Each element thickness is a design variable during the structural optimization routine.

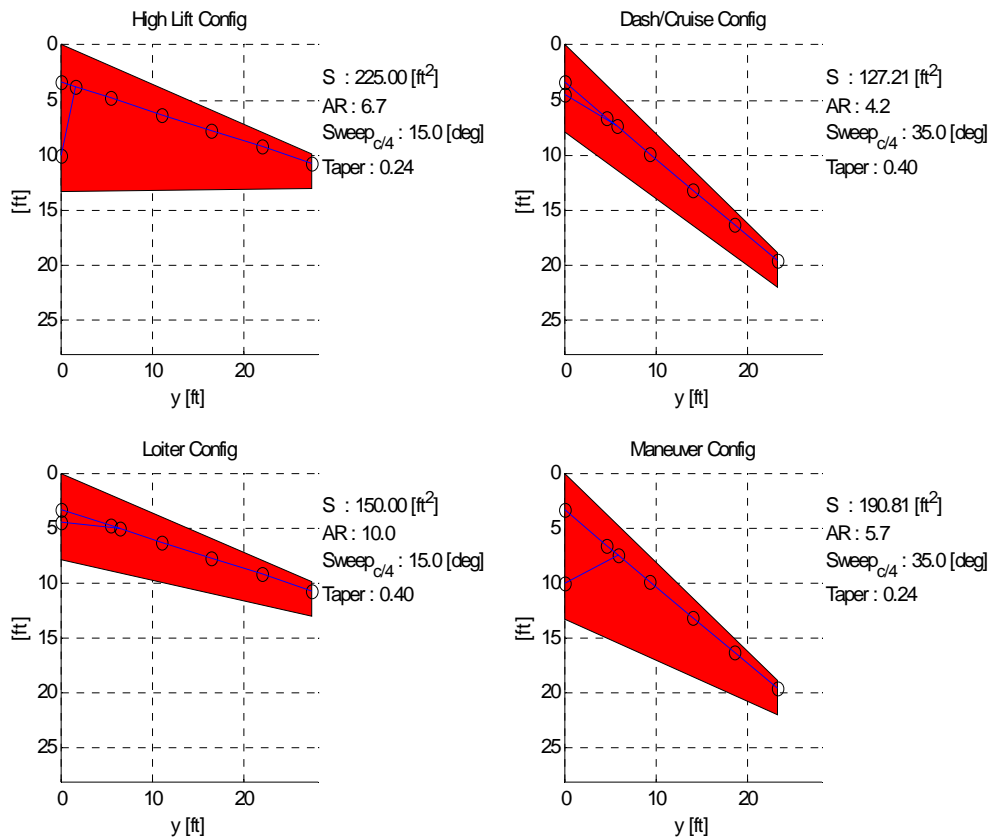

**Figure 5 Planform View of the Four Main Wing Configurations**

#### 4. DOE Results

The mean and standard deviations of wing weights computed for the DOE trials are summarized in the following table. Across the broad range of factors, the standard deviation is large compared to the mean value of weight.

Sample Metric	Value	Unit
Mean Weight	2870	[lb]
Std. Deviation	3310	[lb]

**Table 4 DOE Results**

#### 5. Regression Results

The following Figure illustrates the regression results for the conventional equation form and the full quadratic equation. Here, the structurally sized weight resulting from the FEA optimization is plotted against the predicted weight of the wing using the regressed wing weight equation. The heuristic proved applicable in this case with the conventional equation form fitting the data quite well (a coefficient of correlation of 0.9959). The quadratic equation was unable to predict the data well near the extreme weights (a coefficient of correlation of 0.9783). The coefficient of correlation is a measure of the linearity of the data in the following graphs.

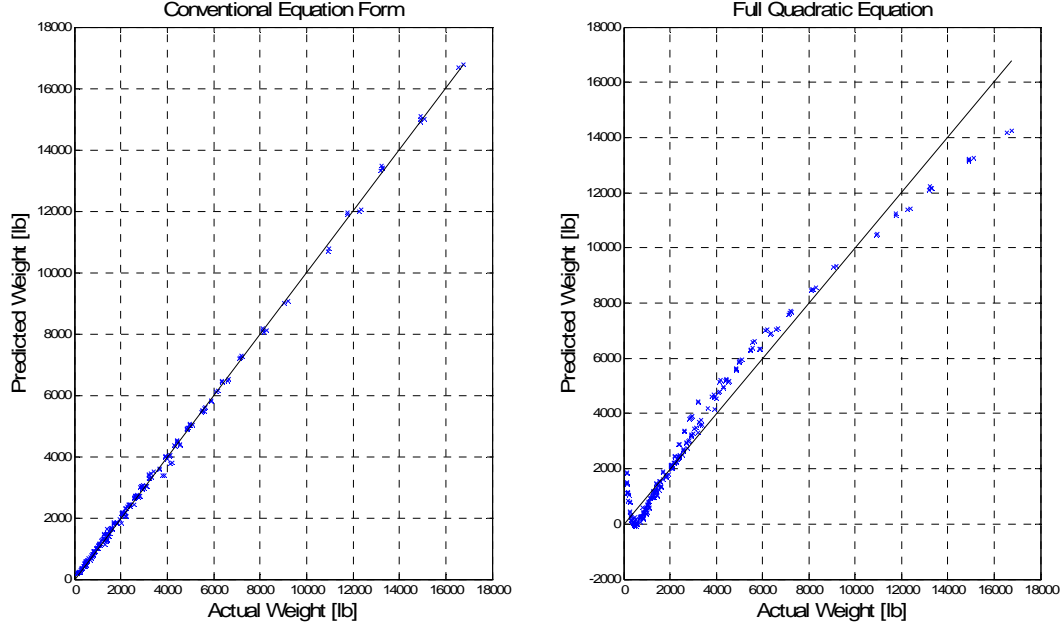

**Figure 6 Comparison of morphing wing weight equations; conventional wing weight equation form (left) and quadratic equation form (right).**

The resulting conventional-basis equation is:

$$W_{\text{wing}} = (0.0352 \cdot W_G) \cdot \frac{S^{0.4516} \cdot (AR)^{1.3520} \cdot (1 + \lambda)^{0.7850} \cdot \left(1 + \frac{\Delta\Lambda}{90}\right)^{0.4524} \cdot (1 + \Delta c_{\text{max}})^{0.0252}}{(1 + \cos \Lambda)^{4.8970} \cdot (100 \cdot t/c)^{0.8870} \cdot \left(\frac{W/S}{10}\right)^{0.0045}} \quad (3)$$

The units for these variables are the same as in Table 3 and the resulting wing weight is in pounds.

### III. Preliminary Morphing Aircraft Sizing

#### A. Overview

Conceptual sizing methods for fixed-geometry aircraft predict the designed weight of an aircraft to perform a given mission based on the values of major aircraft parameters. Six such parameters include wing loading ( $W/S$ ), aspect ratio ( $AR$ ), wing sweep ( $\Lambda$ ), thickness-to-chord ratio ( $t/c$ ), wing taper ratio ( $\lambda$ ), and thrust-to-weight ratio ( $T/W$ ); these particular variables are referred to as the “basic six” because they typically have the greatest impact on aircraft size, weight, and overall flight performance<sup>16</sup>. The conceptual design task, then, is to determine the values of these design variables such that the “sized” aircraft meets all performance requirements at a minimum takeoff gross weight and/or estimated cost; this is typically facilitated with trade studies or formal optimization techniques (gradient-based or global search algorithms).

For a morphing-wing aircraft, the conceptual design task substantially increases in complexity; in addition to the basic six aircraft parameters, the “optimal” variation in wing geometry throughout the design mission must also be determined. The approach used to augment the fixed-wing aircraft sizing task to account for the morphing wing capabilities is the topic of this section.

#### B. Problem Statement

Although the morphing capabilities will increase the number of independent variables during the aircraft sizing routine, the overall problem statement remains the same:

$$\text{Minimize: } W_G \quad (\text{Takeoff Gross Weight}) \quad (4)$$

$$\text{Independent Variables: } \{X_{a.c.}\} \equiv \{W/S, T/W\} \cup \{AR, S, t/c, \lambda, \Lambda\} \cup \{\text{Morphing Parameters}\} \quad (5)$$

**Mission Performance Constraints**

- Takeoff Parameter < 115
- Cruise > Mach 0.7

$$\text{Subject to: } \begin{array}{l} \vdots \\ \bullet \text{ Landing Distance} < 5000 \text{ [ft]} \\ \bullet \text{ Excess Power} \geq 0 \text{ for each mission leg} \end{array} \quad (6)$$

**Variable Bounds**

- $lb_j \leq \{X_{a.c.,j}\} \leq ub_j$

Note that the performance constraints as defined above are neither necessary nor exhaustive, but provide an illustration of the problem statement. The set of wing morphing parameters are the discussion of the next section.

### C. Independent Variable Sets

#### 1. "Photomorphing" Approach

In past research efforts, the traditional sizing approach is modified to incorporate morphing wing capabilities in an approach referred to as "Morphing as an Independent Variable".<sup>17,18,19</sup> Essentially, a mechanization strategy is not defined for the morphing capabilities and the wing geometry is allowed to freely "morph" into different shapes and sizes for each phase of a defined mission profile. This concept of wing morphing has been referred to as "photomorphing", after the popular graphics software program named PhotoShop, in which images can be altered without regard for the physical practicality of the resulting image. This approach requires that the "basic six" design parameters related to the wing geometry be expanded to individual variable sets for each leg of the design mission. Therefore, the independent variable set within the general aircraft sizing problem statement becomes:

$$\text{Independent Variables: } \{X_{a.c.}\} \equiv \{W/S, T/W\} \cup \{AR_i, S_i, t/c_i, \lambda_i, \Lambda_i\} \quad i = 1:m \quad (7)$$

where m is the number of mission legs. Variation of all the wing parameters for each mission leg is not a necessary condition for this problem setup. For example, the following definition of independent variables is also admissible:

$$\text{Independent Variables: } \{X_{a.c.}\} \equiv \{W/S, T/W\} \cup \{\Lambda\} \cup \{AR_i, S_i, t/c_i, \lambda_i\} \quad i = 1:m \quad (8)$$

In this case, the quarter-chord wing sweep is still a variable in the overall problem, but it is constant for each mission leg; the other four wing parameters still vary for each leg of the aircraft design mission.

As highlighted in References 18 and 19, a drawback to this methodology is that the independence of the geometric design variables does not follow any particular mechanization strategy for a morphing wing; solutions to this problem (indicated morphing capabilities) might not be physically implemented. A further concern is that the morphing wing weight predictions rely upon wing weight equations for fixed-geometry aircraft, with a general penalty added to account for structural actuation (See Section 1). While it is unclear how this prediction would compare with an actual structure, it is clear that the accuracy of the prediction will drive the quality of the sizing results.

#### 2. Template-based Approach



A specific morphing wing concept will most likely be restricted in its shape changing capabilities because of the internal mechanization of the wing's substructure. The template-based sizing approach builds on the photomorphing technique by incorporating this idea. The basic concept underlying this approach is the definition of a reference wing geometry. This geometry is described by a set of parameters that uniquely define the overall geometry of the wing. Continuing with the standard set of variables defining the wing, the reference wing geometry will be defined as follows:

$$\{X_{\text{ref}}\} \equiv \{AR, S, t/c, \lambda, \Lambda\} \quad (9)$$

The overall geometry of the morphing wing can now be defined by augmenting the reference geometry with parameters describing the shape variation attributed to morphing,  $\{X_{\text{morph}}\}$ :

$$\{X_{\text{morph}}\} \in \{\Delta b, \Delta c, \Delta \Lambda\} \quad (10)$$

where it is noted that the set can be defined using a single parameter, or any combination thereof because they are linearly independent. Here,  $\Delta b$  and  $\Delta c$  represent the percentage increase in span and chord length with respect to the corresponding reference geometry values. The  $\Delta \Lambda$  term is a normalized parameter describing the change in quarter-chord sweep angle. Mathematically, these parameters could define a morphed wing geometry described by the following functions:

$$\begin{aligned} b_i &\equiv (1 + \Delta b_i) \cdot b_{\text{ref}} \\ c_i &\equiv (1 + \Delta c_i) \cdot c_{\text{ref}} \\ \Lambda_i &\equiv \Lambda_{\text{ref}} + (\Delta \Lambda_i) \cdot (\pi / 2) \end{aligned} \quad (11)$$

$$S_i = f(b_i, c_i, \Lambda_i)$$

$$AR_i = f(b_i, c_i, \Lambda_i)$$

Other wing parameters,  $\{t/c, \lambda\}$ , would be updated as a function of the parameter values similar to  $S_i$  in the previous equation. Thus, the definition of a reference geometry parameter set, morphing variable set, and update formulas to describe a "morphed" wing shape is synonymous with the definition of a "template" in Part II.C of this report. However, in this case, knowledge of the internal mechanization strategy of the substructure is unnecessary, but still reflected in the geometry update formulas (equation set 9).

The template-based aircraft sizing approach requires that the morphing parameters be expanded to individual variable sets for each leg of the design mission. Therefore, the independent variable set within the general aircraft sizing problem statement becomes:

$$\text{Independent Variables: } \{X_{\text{a.c.}}\} \equiv \{W/S, T/W\} \cup \{X_{\text{ref}}\} \cup \{X_{\text{morph}}\}_i \quad i = 1:m \quad (12)$$

$$\{X_{\text{morph}}\}_i \in \{\Delta b_i, \Delta c_i, \Delta \Lambda_i\} \quad (13)$$

where  $i$  represents a leg of the aircraft design mission, and  $m$  defines the number of mission legs.

As is currently defined, the following formulation for wing geometry in terms of a reference geometry and a set of morphing parameters could lead to a non-unique design space; that is, multiple sets of wing parameter values could lead to the same morphed wing shape, leading to an ill-conditioned aircraft sizing problem. Therefore, the following constraints are imposed to avoid this condition:

$$\begin{aligned} \Delta b_i &\geq 0 & \prod_{i=1}^m \Delta b_i &= 0 \\ \Delta c_i &\geq 0 & \prod_{i=1}^m \Delta c_i &= 0 \\ \Delta \Lambda_i &\geq 0 & \prod_{i=1}^m \Delta \Lambda_i &= 0 \end{aligned} \quad (14)$$

These constraints ensure that the reference wing geometry represents the minimum morphing parameter value (i.e. zero if the equality constraints are satisfied) for at least one of the mission legs. Equivalently stated, the reference wing reflects the minimum span length, chord length, and sweep angle the wing will take on over the course of the mission. Notice that this formulation does not force us to impose the reference wing geometry at a given mission leg, but does allow the reference wing geometry to be an admissible shape at some point during the mission.

#### D. Aircraft Weight Prediction

The gross weight of the aircraft is predicted during the aircraft sizing routine via the following equation:

$$W_G = W_{\text{Empty}} + W_{\text{Fuel}} + W_{\text{crew}} + W_{\text{Fixed}} \quad (15)$$

where the aircraft empty weight is predicted using parametric equations for the major structural components (e.g. fuselage, wing, horizontal/vertical stabilizers, pylons, etc.), the fuel weight is determined by simulating the flight of the aircraft design mission via governing equations of flight and general heuristics for fuel consumption, the crew weight is determined by mission specifications, and the fixed weight accounts for any miscellaneous items that should be accounted for in the weight prediction. Notice that the only nontrivial weight estimate is that for the morphing wing. Methods to approximate the morphing wing weight are the subject of the following sections.

##### 1. Wing Weight Prediction via “Photomorphing”

In the case that the wing is allowed to change shape via the photomorphing approach, the wing weight is calculated using a fixed-wing weight equation and then adding a weight estimate for the extent of morphing capabilities. More specifically, the fixed-wing weight is calculated for each wing shape during the design mission, and the representative fixed-wing weight is the maximum of these. The weight estimate for the morphing capabilities is determined by calculating the maximum variation in planform area from one mission leg to the next and applying a weight factor 5 pounds per square foot to this change in wing area; this is described in further detail in Reference 17.

##### 2. Wing Weight Prediction via Template-based Morphing Wing Weight Predictor

Given that the aircraft sizing process is setup via the template-based approach, a response surface based wing weight equation can be developed through the methods defined in Part II of this report. Direct application of this equation in the empty weight prediction is then a trivial task, requiring only the reference wing geometry and maximum morphing parameter values; both of which are included in the aircraft sizing design variable set.

#### E. The Optimization Problem

The aircraft sizing algorithm is implemented within Matlab using *fmincon* – a gradient-based optimization routine using an SQP algorithm. The problem statement is the same as displayed in Section B except for an additional constraint that forces the gross weight of the aircraft (a design variable) to be within one pound of the calculated aircraft gross weight (sum of empty weight, fuel weight, crew weight, and fixed weights). This is illustrated in further detail in Reference 17.

#### F. Case Study

The following case study illustrates results of the described methods using a variable sweep / variable chord morphing wing concept similar to the NextGen Aeronautics concept.

##### 1. Mission Definition

The following figure and table defines the aircraft design mission for this case study. Note that the wing shapes for the decent legs have no bearing on the sizing results; a fuel fraction heuristic is used to determine fuel weight and no range credit is allotted for this leg such that the wing shape has no effect on the aircraft gross weight. Therefore, design variables are not needed for these mission legs.

## 2. Definition of the Wing Template

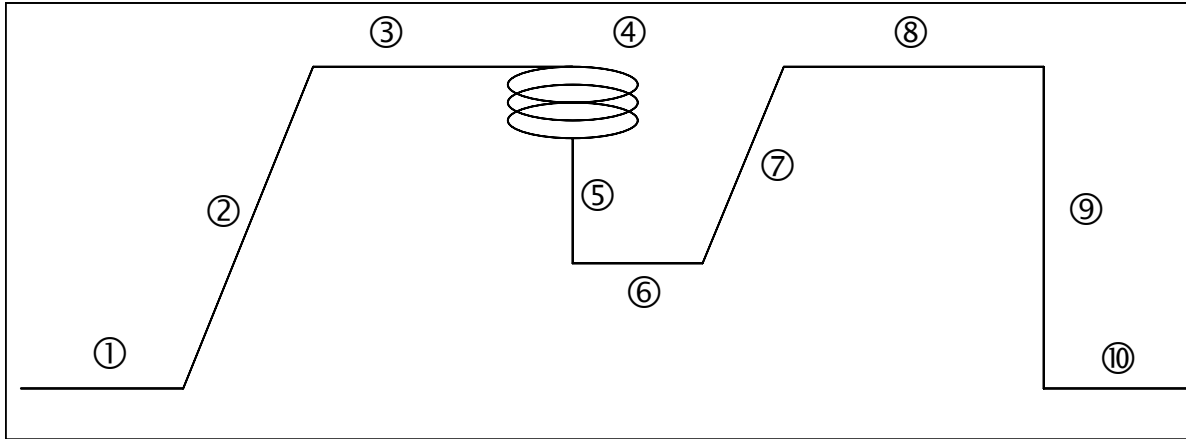

**Figure 7 Design Mission Profile**

The variable sweep / variable chord concept is capable of direct variation of the quarter-chord sweep angle and root chord length. Indirectly, changes in planform area, aspect ratio, taper, and thickness-to-chord ratio are also realized. The following sets define the wing geometry and its morphing capabilities:

Leg	Description	Details	Constraints
1	Startup, Taxi, Takeoff	Altitude: [0] ft	TOP <= 115
2	Climb	Altitude: [0 30]x1000 ft	
3	Cruise	Altitude: [30 30]x1000 ft Leg Distance: 1500 nm	Cruise Speed >= Mach 0.7
4	Loiter	Altitude: [30 30]x1000 ft Endurance: 4 hrs	
5	Decent	Altitude: [30 5]x1000 ft	
6	Dash	Altitude: [5 5]x1000 ft Leg Distance: 250 nm	Dash Speed >= Mach 0.8
7	Climb	Altitude: [5 30]x1000 ft	
8	Cruise	Altitude: [30 30]x1000 ft	
9	Decent	Altitude: [30 0]x1000 ft	
10	Land, Taxi, Shutdown	Altitude: [0] ft	Landing Distance <= 5500 [ft]

**Table 5 Mission Leg Details**

$$\{X_{ref}\} \equiv \{AR, S, t/c, \lambda, \Lambda\} \quad (16)$$

$$\{X_{morph}\} \equiv \{\Delta c_{root}, \Delta \Lambda\} \quad (17)$$

Two variables are needed for each mission leg to describe the morphing parameters. Therefore, a total of 16 design variables are needed to define the shape variation for the entire mission (the wing shapes for the decent legs are not designed). Other modeling assumptions include:

- The length of the quarter-chord line in the reference wing geometry is invariant
- The thickness to chord ratio remains constant during morphing
- The change in sweep angle ( $\Delta \Lambda$ ) refers to the change in quarter-chord sweep angle
- The chord at the wing tip remains constant in length and is oriented parallel to the flow (this was also assumed during the development of the wing weight equation)

## 3. Sizing Results

### a) Photomorphing Results

In the case that the photomorphing wing weight estimate is used in conjunction with the variable sweep / variable span wing template in the aircraft sizing routine, the sized aircraft has the following characteristics:

Weights		
W_G	32489.5	[lb]
W_Fuel	14959.3	[lb]
W_Empty	17030.1	[lb]
W_Wing	1769.5	[lb]

**Table 6 Weight Summary of Sized Aircraft using Photomorphing Wing Weight Estimate**

The wing geometries are illustrated in Figure 8.

*b) Variable Sweep / Variable Span Wing Weight Equation*

In this case, a morphing wing weight equation was developed for the variable sweep / variable span template using the methods from part II. The developed wing weight equation, which is a function of the reference wing geometry and the morphing parameters ( $\{\Delta\Lambda, \Delta c_{root}\}$ ), has the following form:

$$W_{wing} = (0.0352 \cdot W_G) \cdot \frac{S^{0.4516} \cdot (AR)^{1.3520} \cdot (1 + \lambda)^{0.7850} \cdot \left(1 + \frac{\Delta\Lambda}{90}\right)^{0.4524} \cdot (1 + \Delta c_{max})^{0.0252}}{(1 + \cos \Lambda)^{4.8970} \cdot (100 \cdot t/c)^{0.8870} \cdot \left(\frac{W/S}{10}\right)^{0.0045}} \quad (18)$$

where the following basic units are assumed (ft, lb, deg). Using this wing weight equation, in conjunction with the variable sweep / variable span wing template during the aircraft sizing routine, the resulting sized aircraft has the following characteristics:

Weights		
W_G	26495.0	[lb]
W_Fuel	11662.4	[lb]
W_Empty	14332.6	[lb]
W_Wing	1767.7	[lb]

**Table 7 Weight Summary of Sized Aircraft using the Variable Sweep / Variable Span Wing Weight Equation**

The “optimal” wing geometries appear in Figure 8.

*c) Summary of Results*

The following figure illustrates the wing planform shapes for the resulting aircraft sized using the photomorphing wing weight prediction and the response surface based wing weight equation.

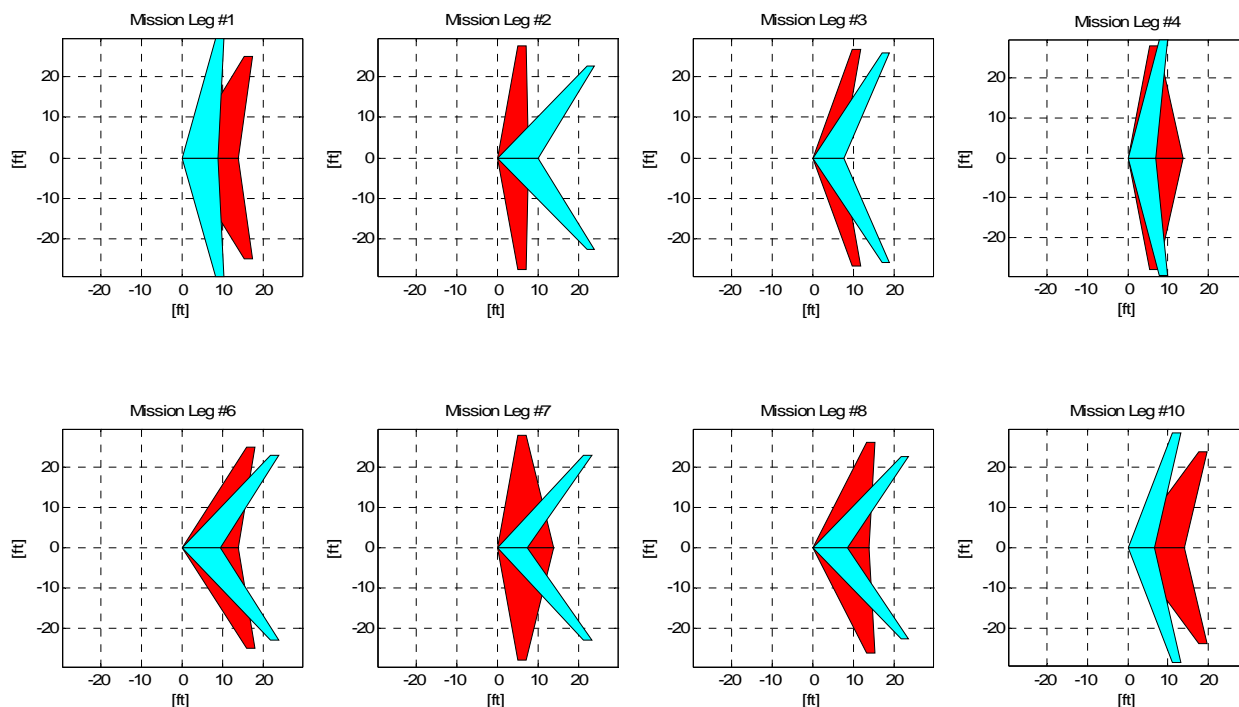

**Figure 8 Superposed wing planform sizing results using the Variable Sweep / Variable Chord Template (Red – Photomorphing wing wt. prediction; Cyan – Response surface based wing weight equation)**

The wing weight prediction alone has a significant impact on the optimal shape of the wing throughout the design mission. This is an important result, because it suggests that an accurate wing weight prediction is necessary to determine the overall size of the wing and the required extent of morphing actuation during the preliminary design phase. Substantial deviation of the fully designed wing weight from the estimated wing weight during preliminary design could lead to an aircraft unable to meet the overall mission requirements.

#### IV. Conclusions and Suggested Future Efforts

The overall process of developing a morphing wing weight equation and directly incorporating the weight estimate into a template-based sizing code tends to be a viable methodology. The particular morphing wing weight estimation used during aircraft sizing was shown to drastically affect the “optimal” wing sizes and shapes taken on during the course of the design mission. This substantiates the need for a credible wing weight prediction early in the conceptual design phase to establish the necessary morphing capabilities.

The conceptual idea behind the development of the morphing wing weight equation is relatively straightforward. However, implementation of the overall process unveils several problematic areas that must be approached with rigor to establish credible wing weight estimates. For example, the structural sizing process (the simultaneous analysis optimization approach) must be implemented to avoid the potential over-prediction caused by sequential optimization approaches. The method to perform this process is in place for the intermediate complexity model but has not yet been implemented. The validation and feasibility of this approach is of paramount importance and will be addressed as soon as an appropriate FEA environment is in place. Of further concern is the modeling of morphing wing skins in the FEM (skin material that undergoes strain as a direct result of rearrangement of the substructure). Currently, this issue is not formally addressed as it is unclear how to model the material behavior, load carrying capabilities, and failure modes. Although not addressed here, these materials are being developed, tested, and, in the MAS program, incorporated into morphing structures. For example, shape memory polymers were used in Lockheed’s folding wing design<sup>3</sup>; the NextGen concept incorporates a “flexible skin for the wing that ... smoothly accommodate(s) desired changes in the surface area<sup>20</sup>”; and a recently-initiated DARPA program will

research and develop materials having characteristics similar to the cellular structure and behavior of plants (nastic materials) for use in adaptive / morphing structures.<sup>21</sup> Finally, the actuation system has been modeled here using simplified hydraulic actuators. Although this type of actuation scheme is conventional, a morphing wing would more likely use compact hybrid actuators<sup>22,23</sup> as a means of weight and volume savings to increase overall system feasibility; these actuators will have increased power density and reduced volume compared to conventional actuation systems. However, weight estimates of these systems are currently unavailable or proprietary and can not be incorporated in an academic environment. Furthermore, this work assumes that the wing morphing is a quasi-static process with linearly varying loads. If the wing is desired to operate / morph within a high frequency range, the actuator sizing could be driven more by inertia and unsteady aerodynamic effects rather than loads due to friction and structural rearrangement. These concerns should be addressed in subsequent work.

The template-based aircraft sizing routine enables sizing of an aircraft utilizing morphing wings with a specified mechanization strategy. This is important because resulting morphing wing capabilities will be physically realizable. An important consideration, however, is that the aircraft sizing routine requires on the order of one hour dedicated runtime (good initial guess for the design variables) to five hours (poor initial guess or over-constrained problem statement); these values are based on a dedicated desktop computer, Pentium IV processor (2.8 GHz), running Windows XP and Matlab 7.1 (R14). Techniques are currently being considered to expedite runtime performance by systematically decomposing the problem into a hierarchy of sizing-related subproblems; the overall goal and template-based modeling approach would be preserved, however. Finally, further studies are suggested to verify global optimality of the aircraft sizing results. While the obtained results seem reasonable, the optimality has not yet been established.

### Acknowledgments

NASA Langley Research Center supported this work via Research Grant No. NNL06AA04G. The authors thank the support of their technical monitor, Dr. Jamshid Samareh. Additional discussions with Mike Love and Scott Zink of Lockheed Martin Aeronautics and with Jay Kudva, Shiv Joshi and Akhilesh Jha of NextGen Aeronautics were helpful in understanding current design approaches for morphing wing structures.

### References

- <sup>1</sup>Wall, R., "Darpa Eyes Materials for 'Morphing' Aircraft," *Aviation Week and Space Technology*, April 8, 2002.
- <sup>2</sup>"Morphing Aircraft Structures," DARPA Defense Sciences Office, [<http://www.darpa.mil/dso/trans/mas.htm>], accessed Nov. 2006.
- <sup>3</sup>Lawlow, M., "The Shape of Wings to Come," *SIGNAL* [online journal], Oct. 2006, URL: [http://www.afcea.org/signal/articles/templates/SIGNAL\\_Article\\_Template.asp?articleid=1205&zonedid=56](http://www.afcea.org/signal/articles/templates/SIGNAL_Article_Template.asp?articleid=1205&zonedid=56) [cited 31 October 2006].
- <sup>4</sup>Staton, R.N., "Statistical Weight Estimation Methods for Fighter/Attack Aircraft," Vought Aircraft Rept. 2-59320/8R-50475, 1968.
- <sup>5</sup>Shanley, F.R., *Weight-Strength Analysis of Aircraft Structures*, 2<sup>nd</sup> Ed., Dover Publications, New York, 1960.
- <sup>6</sup>Balabanov, V., Kaufman, M. Knill, D. L., Haim, D., Golovidov, O., Guinta, A. A., Haftka, Raphael T., Grossman, B., Mason, W. H., and Watson, L. T., "Dependence of Optimal Structural Weight on Aerodynamic Shape for a High Speed Civil Transport," AIAA 1996-4046, 6th AIAA/ISSMO/NASA Symposium on Multidisciplinary Analysis and Optimization, Bellevue, WA, Sept. 4-6, 1996, Technical Papers. Pt. 1 (A96-38701 10-31).
- <sup>7</sup>Skillen, M., "Developing Response Surface Based Wing Weight Equations for Conceptual Morphing Aircraft Sizing," MS Thesis, School of Aeronautics and Astronautics, Purdue University, West Lafayette, IN, Dec. 2005.
- <sup>8</sup>Skillen, M., and Crossley, W., "Developing Response Surface Based Wing Weight Equations for Conceptual Morphing Aircraft Sizing," AIAA-2005-1960, 46<sup>th</sup> AIAA/ASME/ASCE/AHS/ASC Structures, Structural Dynamics, and Materials Conference and 13<sup>th</sup> AIAA/ASME/AHS Adaptive Structures Conference, Austin, Texas, Apr. 18-21, 2005.
- <sup>9</sup>Love, M. H., Zink, P. S., Stroud, R. L., Bye, D. R., Chase, C., "Impact of Actuation Concepts on Morphing Aircraft Structures," AIAA 2004-1724, 45<sup>th</sup> AIAA/ASME/ASCE/AHS/ASC Structures, Structural Dynamics, and Materials Conference, Apr. 2004.
- <sup>10</sup>Skillen, M., and Crossley, W., "Developing Morphing Wing Weight Predictors with Emphasis on the Actuating Mechanism," AIAA-2006-2042, 47<sup>th</sup> AIAA/ASME/ASCE/AHS/ASC Structures, Structural Dynamics, and

Materials Conference and 14<sup>th</sup> AIAA/ASME/AHS Adaptive Structures Conference, Newport, Rhode Island, May 1-4, 2006.

- <sup>11</sup>Bertin, J.J., *Aerodynamics for Engineers*, 4<sup>th</sup> Ed., Prentice Hall, Upper Saddle River, New Jersey, 2002.
- <sup>12</sup>MATLAB, Software Package, Ver. 7.1.0.246, Release 14, The MathWorks, Inc., Natick, MA, 2005.
- <sup>13</sup>“ASTROS, *Theoretical Manual for Version 20*.” Torrance, CA, Universal Analytics, Inc. 1997.
- <sup>14</sup>MSC Nastran, Software Package, MSC Software, Inc., Santa Ana, CA.
- <sup>15</sup>“iSIGHT 6.0 Product Specifications,” Engineous Software, Inc., [<http://www.engineous.com/specifications.htm#>], accessed Jan. 2006.
- <sup>16</sup>Raymer, D., *Aircraft Design: A Conceptual Approach*, AIAA Education Series, American Institute of Aeronautics and Astronautics, Reston VA, 3<sup>rd</sup> Edition, 1999.
- <sup>17</sup>Frommer, J., and Crossley, W., “Enabling Continuous Optimization for Sizing Morphing Aircraft Concepts,” AIAA-2005-0816, 43<sup>rd</sup> AIAA Aerospace Sciences Meeting and Exhibit, Reno, Nevada, Jan. 10-13, 2005
- <sup>18</sup>Roth, B., Peters, C., and Crossley, W. A., “Aircraft Sizing with Morphing as an Independent Variable: Motivation, Strategies and Investigations,” AIAA-2002-5840, 2<sup>nd</sup> AIAA Aircraft Technology, Integration, and Operations (ATIO) 2002 Forum, Los Angeles, CA, Oct. 2002.
- <sup>19</sup>Roth, B. and Crossley W. A., “Application of Optimization Techniques in the Conceptual Design of Morphing Aircraft”, AIAA-2003- 6733, 3<sup>rd</sup> AIAA ATIO Forum, Denver, CO, Nov. 17-19, 2003.
- <sup>20</sup>Ashley, S., “Flying on Flexible Wings,” *Scientific American*, November 2003, pp. 84-91.
- <sup>21</sup>“Nastic Materials,” DARPA Defense Sciences Office, [<http://www.darpa.mil/dso/thrust/matdev/nastic.htm>], accessed Nov. 2006.
- <sup>22</sup>“Compact Hybrid Actuator Program,” DARPA Defense Sciences Office, [<http://www.darpa.mil/dso/thrust/matdev/chap.htm>], Accessed Nov. 2006.
- <sup>23</sup>Anderson, E. and Lindler, J., “Smart Material Actuator with Long Stroke and High Power Output,” AIAA 2002-1354, 43<sup>rd</sup> AIAA/ASME/ASCE/AHS/ASC Structures, Structural Dynamics, and Materials Conference, Denver, CO., Apr. 22-25, 2002.

## Appendices

### A. Examples of Template-Based Morphing FEM's

#### Rigid Body Variable Sweep Template

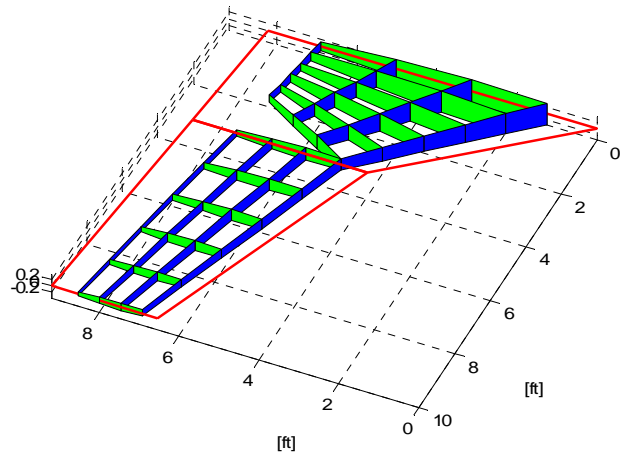
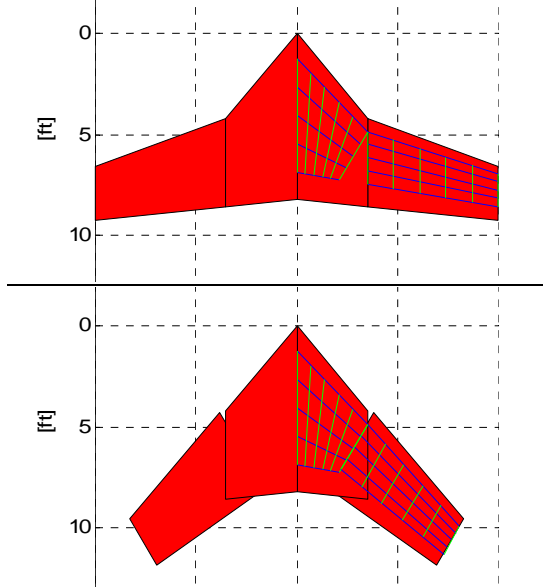

#### Shear Sweep Template

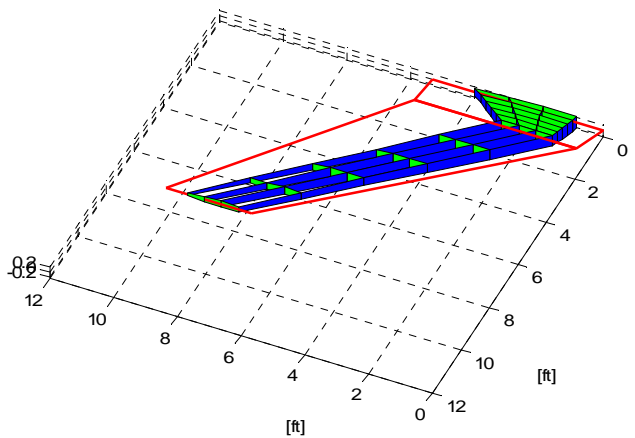
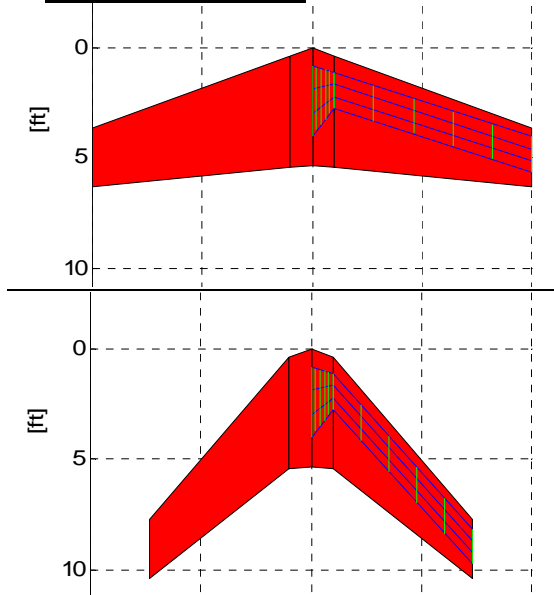



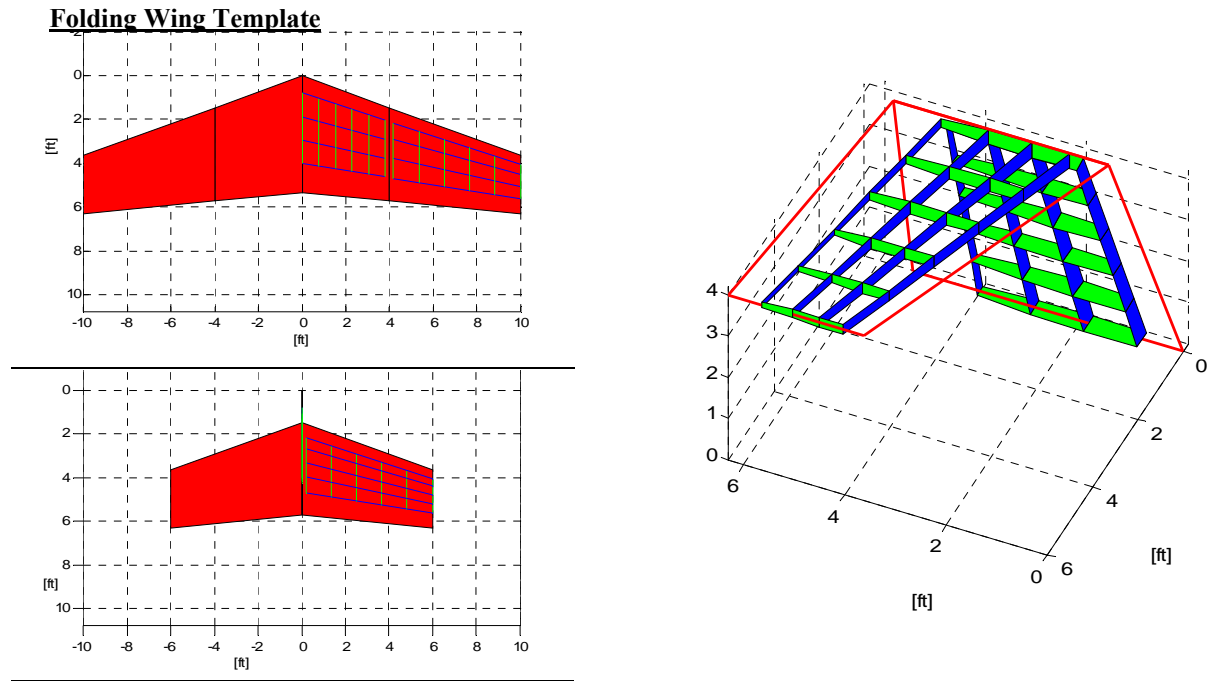

**B. Overall Process Implementation for the Beam Model Representation**

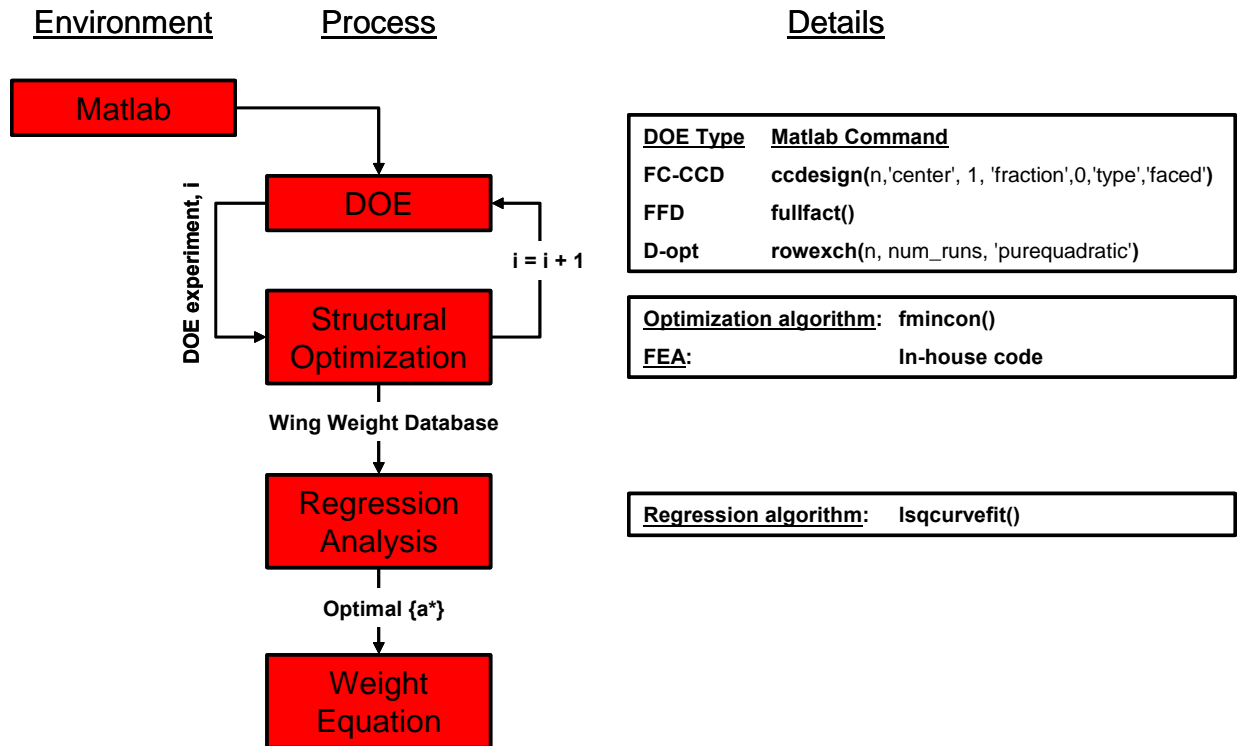

**Figure 9 Overall Process Implementation for the Beam Model Representation**

C. Overall Process Implementation for the Intermediate Complexity Model

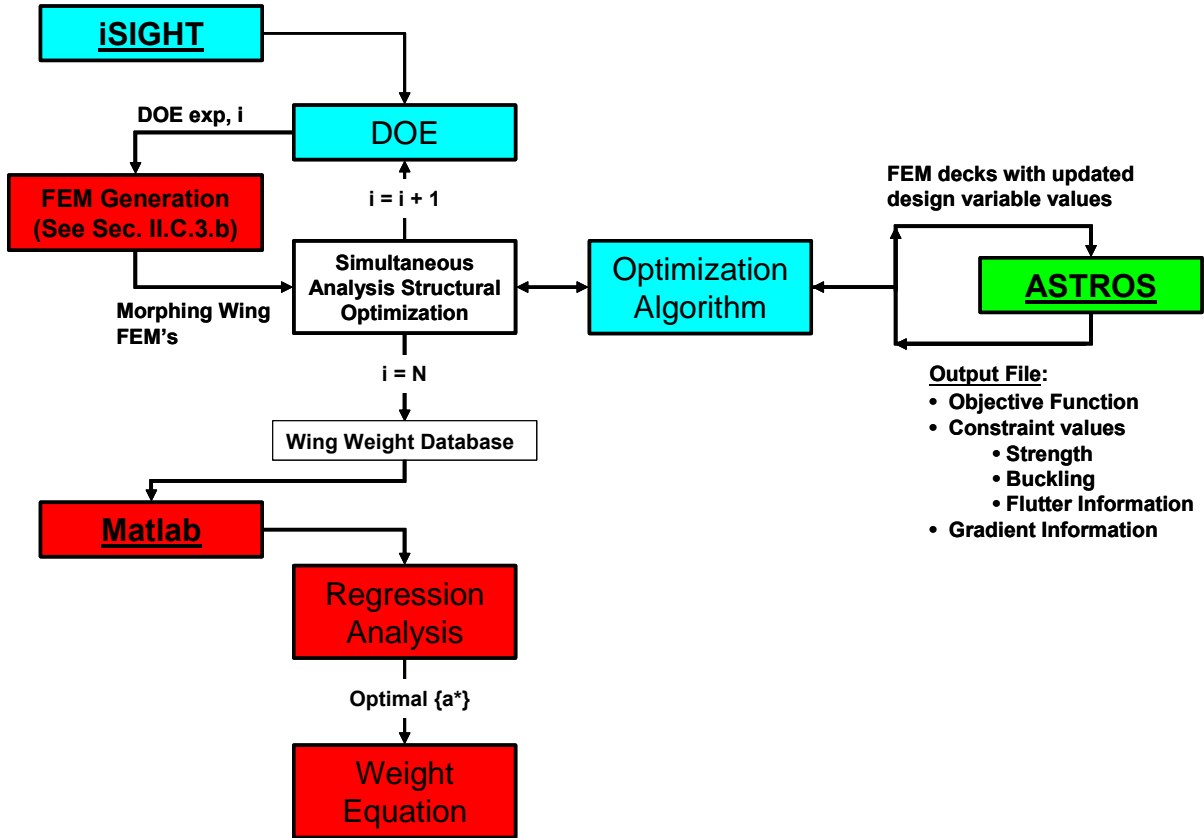

Figure 10 Overall Process Implementation for the Intermediate Complexity Model

