

# The Microgravity Science Glovebox (MSG), a Resource for Gravity-Dependent Phenomena Research on the International Space Station (ISS)

Reggie A. Spivey\*

*Tec-Masters Inc., Huntsville, Alabama, 35806*

Linda B. Jeter†

*NASA Marshall Space Flight Center, Huntsville, Alabama, 35812*

And

Chris Vonk‡

*Bradford Engineering, 4726 TG Heerle (NB)  
The Netherlands*

The Microgravity Science Glovebox (MSG) is a double rack facility aboard the International Space Station (ISS) designed for gravity-dependent phenomena investigation handling. The MSG has been operating in the ISS US Laboratory Module since July 2002. The MSG facility provides an enclosed working area for investigation manipulation and observation in the ISS. The MSG's unique design provides two levels of containment to protect the ISS crew from hazardous operations. Research investigations operating inside the MSG are provided a large 255 liter work volume, 1000 watts of dc power via a versatile supply interface (120, 28,  $\pm 12$ , and 5 Vdc), 1000 watts of cooling capability, video and data recording and real time downlink, ground commanding capabilities, access to ISS Vacuum Exhaust and Vacuum Resource Systems, and gaseous nitrogen supply. With these capabilities, the MSG is an ideal platform for research required to advance the technology readiness levels (TRL) needed for the Crew Exploration Vehicle and the Exploration Initiative. Areas of research that will benefit from investigations in the MSG include thermal management, fluid physics, spacecraft fire safety, materials science, combustion and reacting control systems, in situ fabrication and repair, and advanced life support technologies. This paper will provide a detailed explanation of the MSG facility, a synopsis of the research that has already been accomplished in the MSG, an overview of investigations planning to operate in the MSG, and possible augmentations that can be added to the MSG facility to further enhance the resources provided to investigations.

---

\* SDOS MSG Project Manager, MSFC ISS Payloads Office, VP35, AIAA Member.

† NASA MSG Lead Systems Eng, MSFC Engineering Directorate, VP35, AIAA Member

‡ MSG Project Engineer, Bradford Engineering, Spaceflight Components and Systems

## I. Introduction

The Microgravity Science Glovebox (MSG), shown in Fig. 1, is a research facility on-board the International Space Station (ISS) in which fundamental and applied scientific research is conducted that supports NASA's Vision for Space Exploration. The unique design of the facility allows it to accommodate science and technology investigations in a "workbench" type environment. The facility has an enclosed working volume that is held at a negative pressure with respect to the crew living area. This allows the facility to provide two levels of containment for small parts, particulates, fluids, and gasses. The containment provided by the facility reduces the safety requirements placed on the payload developer and facilitates the development of flight hardware in close parallel with prototype or breadboard hardware developed in ground based laboratories. Research investigations operating inside the MSG are provided a large 255 liter work volume, 1000 watts of dc power via a versatile supply interface (120, 28,  $\pm 12$ , and 5 Vdc), 1000 watts of cooling capability, video and data recording and real time downlink, ground commanding capabilities, access to ISS Vacuum Exhaust and Vacuum Resource Systems, and gaseous nitrogen supply. With these capabilities, the MSG is an ideal platform for research required to advance the technology readiness levels (TRL) needed for the Crew Exploration Vehicle and the Exploration Initiative. In addition, the facility is ideally suited to provide quick access to space for exploratory type investigations that are necessary to gain an initial understanding of the role of gravity in the physics associated with new research areas.

To facilitate the use of the MSG by the scientific community, an integration team of engineers and support personnel is available at the Marshall Space Flight Center (MSFC) to assist researchers with the complex task of building and operating an experiment for space. The team advises experiment development groups on engineering issues during the design phase of their investigation, assists with ISS manifesting and planning, and provides support through the testing and analysis activities that are required to assure that experiments are compliant with ISS safety and interface requirements. An engineering unit and development unit is available at MSFC for use during payload development, verification, and on-orbit operation. A high fidelity training unit is located at the Johnson Space Center for training of ISS crew members. Once experiments are transported to the ISS, either by the NASA Shuttle or the Russian Soyuz or Progress vehicles, the crew installs the experiment hardware in the MSG and configures it for operation. Depending on its design, the actual experiment can be conducted either by the crew or by the ground-based investigator through two-way real-time data links. Experiment progress can be monitored from the ground through the several MSG video cameras, or cameras embedded in the experiment. A telescience center at MSFC provides investigators a link to interact with the experiment during flight operations. The investigator can be located at either MSFC or their home laboratory, where they are connected via communication links.

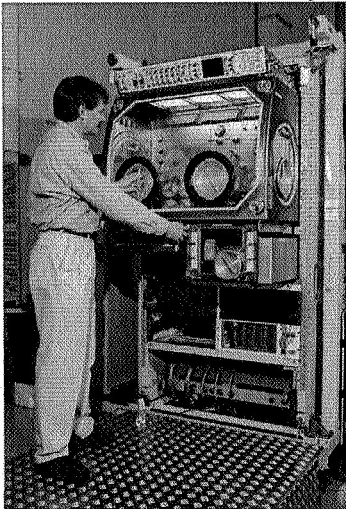

Figure 2. The MSG Rack

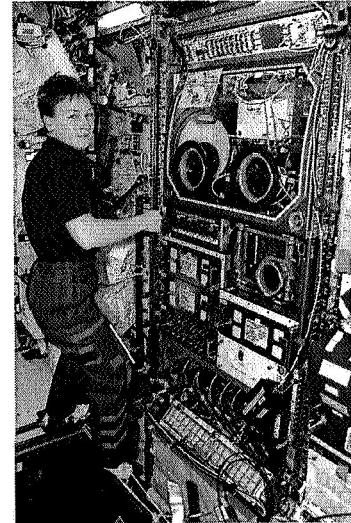

Figure 1. The MSG Flight Unit with Astronaut Peggy Whitson.

## II. Payload Interfaces and Resources Provided by MSG

The MSG facility is designed to be a versatile platform for space based research. Many of the resources and interfaces found in the MSG are compatible with those typically found in a ground based laboratory. Table 1 provides a summary of the resources provided to experiments inside the MSG facility. The following paragraphs provide a general over view of the MSG capabilities. Additional detail is available on the MSG web site at <http://glovebox.msfc.nasa.gov/>.

### A. The MSG Work Volume

The MSG work volume, as shown in Fig. 2 & Fig. 3, provides a large area for set up and operation of experiment hardware. Payloads are loaded into the work volume via the 406mm (16 in.) diameter loading ports

**Table 1. MSG Experiment Resource Summary**

<b>RESOURCE</b>	<b>DESCRIPTION</b>
POWER	Three power interfaces are provided in the WV. <ul style="list-style-type: none"> <li>• one 120 V DC, 8.3 Amp</li> <li>• two 28V DC/7 A, ± 12V DC/2A, 5V DC/4A</li> </ul> Continuous power allocated to experimenter is a maximum of 1000 watts.
DATA	Eight data interfaces are provide in the WV (two 1553 for MLC). <ul style="list-style-type: none"> <li>• two digital (I/O) and analog input lines</li> <li>• two RS 422 serial lines</li> <li>• one connection to the Ethernet interfaces</li> <li>• one RS-422/RS232 feedthrough from the back wall to the front of the rack for MLC use outside the WV to an investigation inside the WV</li> <li>• one user configurable feedthrough at the corner of the front window.</li> </ul>
VIDEO	<ul style="list-style-type: none"> <li>• two Sony DSR-V10 DV-CAM digital video recorders (40 min/tape)</li> <li>• two GV-A500 Hi-8 analog video recorders (240 min/tape)</li> <li>• four Hitachi HV-C20 CCD full color cameras</li> <li>• two multi-input LCD monitors for crew monitoring,</li> </ul>
EXPERIMENT LAPTOP COMPUTER	IBM A31p with a 60 gigabyte hard drive and 1 gigabyte of RAM. 1 Ethernet, 1 RS232/422 (via converter), and USB (via operating system) interfaces. Windows 2000 (Service Pack 4) Operating System.
STRUCTURAL	The WV provides for the attachment of hardware either by M6 inserts or bungee cords. <ul style="list-style-type: none"> <li>• Cold Plate: 24 M6 inserts in a 70 X 70 mm pattern</li> <li>• Airlock Top Lid: 18 M6 inserts in a 70 X 70 mm pattern</li> <li>• Rear Wall: 20 M6 inserts in a 70 X 70 mm pattern</li> <li>• Access Ports: 27 (each) M6 inserts at 10° pitch</li> <li>• Ceiling: Two locations containing 8 M6 inserts in a 70 X 70 mm pattern</li> </ul>
THERMAL	A total of 1000 W can be dissipated from the WV. <ul style="list-style-type: none"> <li>• Allowable heat dissipation to the Cold Plate = 800 W</li> <li>• Allowable heat dissipation to the Air = 200 W</li> </ul>
VACUUM	Two vacuum interfaces are provided in the WV. <ul style="list-style-type: none"> <li>• Vacuum resource/venting is provided via a 1/2" quick disconnect</li> <li>• Vacuum exhaust/waste is provided via a 1/2" quick disconnect</li> </ul>
GN2	One GN2 interface is provided in the WV via 1/4" quick disconnect.
AIR CIRCULATION	<ul style="list-style-type: none"> <li>• Max airflow rate of 1200 l/min and a max velocity of 0.044 m/s at the centerline of the work volume.</li> <li>• Airflow can be varied between 15% and 100% depending on fan speed settings.</li> <li>• Negative pressures of 1.3 mB to at least 7 mB based on facility settings.</li> </ul>
AIR FILTERING	<ul style="list-style-type: none"> <li>• Three filter banks in series provide WV air filtration. Each bank consists of 8 HEPA filters in parallel (4 front and 4 rear).</li> <li>• Particle filtration down to 0.3 micron size</li> </ul>
WORK VOLUME (WV)	The WV has an approximate volume of 255 liters.
ILLUMINATION	Adjustable lighting available up to 1000 Lux incident light measured at the WV center approximately 200 mm off the WV floor.
AIRLOCK	26 liter volume allows access to the WV during operation without compromising containment.

on the right and left sides. Hardware can be mounted to the floor, ceiling, back, and/or sides using M6 threaded fasteners. An airlock is provided below the work volume which allows items to be passed into the experiment area without compromising containment.

## B. Electrical Power Interfaces

The MSG receives, conditions, and distributes electrical power from the ISS Electrical Power System (EPS) to the MSG work volume for use by the investigation. The experiment hardware is provided a maximum of 1000W of power. The following primary and secondary supply power interfaces are provided inside the work volume.

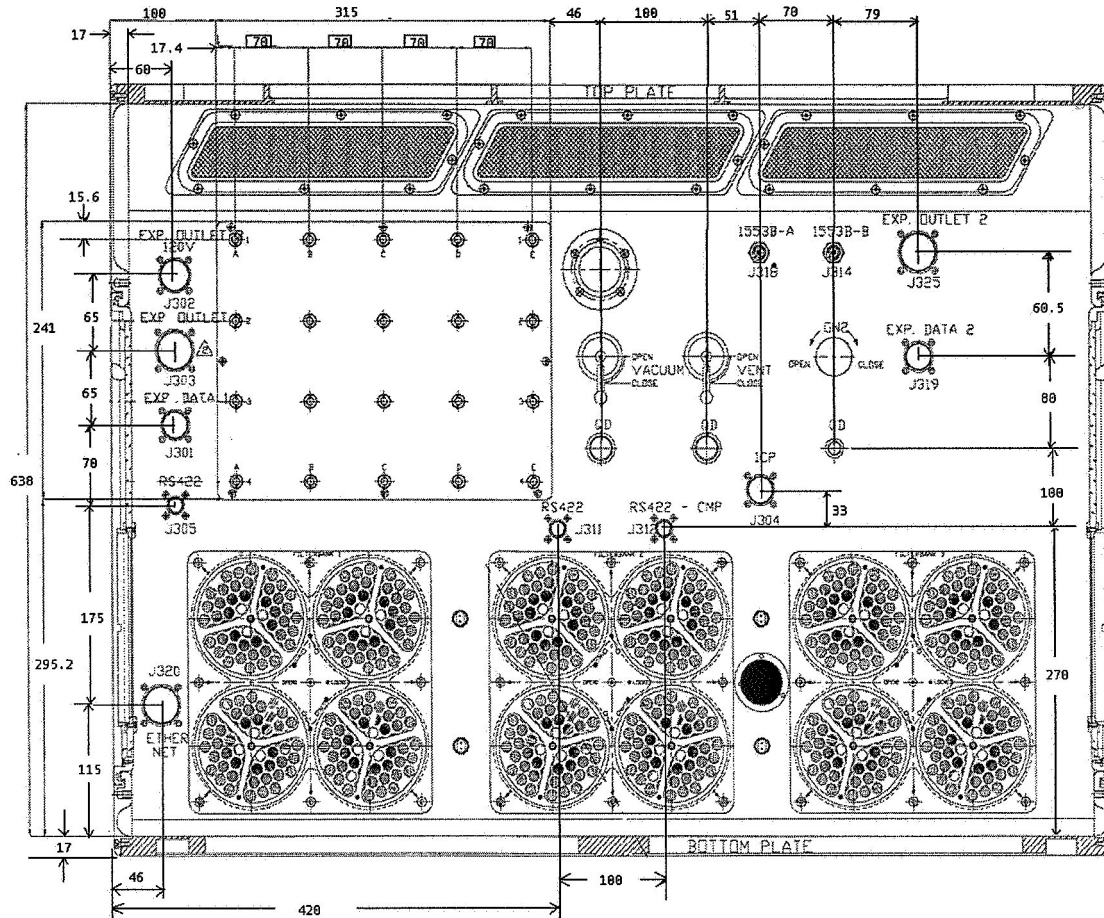

Figure 3. MSG Back Wall Layout.

- Experiment Primary Power  
+120 Vdc Power (120 Vdc, 8.3 A)
- Experiment Secondary Power  
28 Vdc Power, (+28 Vdc, 7 A)  
+12 Vdc Power, (+12 Vdc, 2 A)  
- 12 Vdc Power, (-12 Vdc, 2 A)  
5 Vdc Power, (+5 Vdc, 8 A)

Secondary power sources are converted voltages derived from the DC/DC converters in the MSG Facility. To receive power, experiment hardware must connect to the power supply connectors on the back wall of the work volume shown in Fig. 3. The primary power connector (J302) is supplied on a Mil-Spec type connector MS27656P17F6SA. The experiment must connect to the primary power (120Vdc) with a Mil-Spec type connector MS27467T17F6PA. Secondary power (5,  $\pm 12$ , & 28 Vdc) connectors (J303/J325) are supplied on two MS27656P21F11S connectors in the work volume rear wall as shown in Figure 3. Researchers must connect to secondary power using a connector of type MS27467T21F11P.

### C. Data Handling

The MSG data handling system allows for communication with the MSG facility and experiments plus remote operation of the MSG facility and experiments operating inside the WV. The following interfaces are provided to experiment hardware in the work volume; MIL-STD-1553B (via the laptop computer), RS-422 Serial Interface and Digital Input/Output (I/O) and Analog Input Interface. Investigations are also provided an Ethernet interface that is directly connected to the, ISS Ethernet.

### D. Video Systems

The MSG Video System is provided to observe and record experiment behavior. The MSG Video Drawer consists of the following: four video recorders, multi-input LCD monitors, Hitachi HV-C20 CCD full color cameras, touch-pad, footswitch and a headset/microphone. The video system has the capability to simultaneously record the video signal, display it on the monitors and downlink the video signal to the ground. Experiments that provide their own video cameras must send both Composite and Y/C signals to the MSG video system. The Composite video signal is used to view the camera images on the MSG monitors and for downlinking the video signal. The MSG video recorders require the Y/C video signal. Playback is possible on all of the recorders.

There are several ways to operate the video system; it can be commanded from the ground, manually on the recorder itself or by the use of a touch-pad. The video system provides the capability to annotate text onto the video signal and has a time counting system that can be recorded on the video signal and displayed to the operator. The video system has time-lapse capability that allows for extended recording time. The time-lapse settings have two variables that the investigator can choose from, the length of recording and pause period. The range for the length of recording is 0.5 to 25.5 seconds increasing in intervals of 1/10 a second, and the range for the pause period is 5 to 255 seconds in intervals of 1-second steps.

There are two types of recorders used in the MSG video system: two Sony DSR-V10 DV-CAM digital video recorders with 40 minutes of recording time per digital tape, and two GV-A500 Hi8MM analog recorders with 240 minutes of recording time per tape. Audio can be recorded simultaneously on all four video recorders through the MSG headset/microphone.

### E. Thermal Control Interfaces

The MSG Thermal Control Subsystem (TCS) provides both water cooling and avionics air cooling for experiment hardware. Water cooling is provided by a 350 mm x 400 mm coldplate embedded in the WV floor. The coldplate is located on the left side of the work volume floor and is capable of dissipating 800W under steady state conditions. Experiment hardware is mounted to the coldplate with M6 threaded captive fasteners. Researchers can tighten the fasteners as needed to meet their thermal requirements but they must not to exceed 60 in-lbs of torque.

The work volume air circulation is established by the MSG Air Handling Unit (AHU). The AHU heat exchanger provides 200 W of investigation cooling, at an airflow rate of 1200 l/min and a maximum velocity of 0.044 m/s at the centerline of the work volume. The airflow can be varied between 15% and 100% depending on fan speed settings. The filtration system provides for particulate removal, filtration of single spillage, and oxidation of CO to CO<sub>2</sub> by means of a built-in catalyst. Due to the hygroscopic nature of the MSG filters, the humidity inside the WV is maintained at or below the ISS cabin level. Fig. 4 provides a block diagram of the MSG air flow.

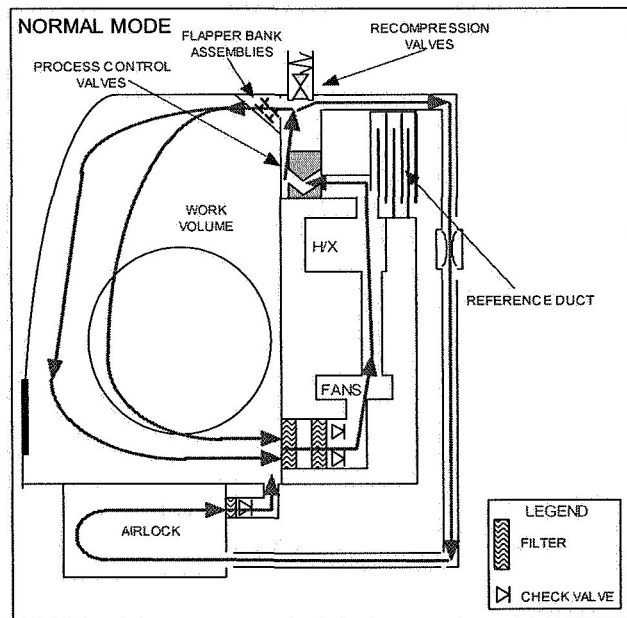

Figure 4. MSG Air Circulation and Filtration.

## F. Experiment Laptop Computer

The current laptop provided to MSG experiments is an IBM A31p with a 60 gigabyte hard drive and 1 gigabyte of RAM. The laptop supports dual Ethernet, 1 RS232/422 (via converter), and USB (via operating system) interfaces. The operating system is Windows 2000 (Service Pack 4).

Researchers are encouraged to use the server system on the laptop that was developed by the MSG integration team. The laptop server system is a suite of applications that executes on the MSG Laptop Computer. The purpose of the laptop server is to abstract the input/output of the system when experiment applications are running and provide support for various on orbit operations. The laptop server abstracts the 1553B interface, the Serial (RS232/RS422) connections and the Medium Rate Data Link (Ethernet). Instead of each application developer spending the time and effort required to get familiar with each of these interfaces, they may concentrate upon their specific application. The laptop server presents to the applications developer a relatively simple Application Program Interface (API) that uses the basic Windows system function calls. The laptop server provides a consistent interface to each application and allows multiple applications to share information through the defined application interface. The laptop server also provides for extensive ground commanding support (Timelines & Process Control) to support un-attended operation. All existing interfaces to the laptop have been verified and used in flight so the risk of having communication problems during on-orbit operations is greatly reduced. Researchers can use a simple web based system that allows them to issue commands and display experiment sensor measurements via HTML. By utilizing the FTP server on the laptop, the experiment can take advantage of the laptop hard drive for storage of data that can then be down linked using the ISS Medium Rate Data Link. In addition, the laptop provides a socket based interface to the 1553 data stream for experiment data output.

## G. Vacuum Resource/Exhaust and GN2 Subsystem

The MSG is connected to the ISS Vacuum Resource, ISS Vacuum Exhaust, and GN2 subsystems. The experiment interface to these services is provided inside the WV. The vacuum resource/vent line may be used to operate a furnace or achieve a coarse vacuum. The vacuum exhaust/waste gas system is used primarily for venting gases or byproducts given off by the experiments. However, the quality of the vacuum at the experiment interface may be lower than the  $1 \times 10^{-3}$  torr at the MSG interface due to pressure drops in the ducts, quick disconnects etc. GN2 can be used to inert the internal atmosphere and may provide means for controlling humidity.

The experimenter is provided with quick disconnects at the rear wall of the WV to interface with the vacuum and GN2 resources. The WV is equipped with manually operated ball valves for the vacuum resource and exhaust lines and a needle valve for the GN2 line. There are limitations on the type of gases and materials that can be exhausted into the ISS vacuum system, and the temperature and pressure of the exhaust gases. See MSFC-RQMT-2888 for detailed information on connector types and interface requirements concerning the vacuum and GN2 subsystem.

## H. Air Circulation and Filtration

The MSG air circulation and filtration system is illustrated by Fig 4 and Fig. 5. The MSG Air Handling Unit (AHU) has three separate fans that draw air from the WV through the filter banks and blows this air through the water to air heat exchanger, the Process Control Valves and into the Air Discharge Duct, where the air is re-directed towards the WV. These fans maintain the WV pressure lower than the cabin pressure. Any potentially contaminated air can only leave the WV via the reference outlet following filtration. When the MSG is operating in Normal mode, the process control valve is set to allow the air in the WV to be recirculated through the filters, the fans, the heat exchanger, and back into the WV. In this mode the WV will maintain a pressure differential of at least 1.3 mbar between the WV and the outside. When MSG is operating in Sealed mode, the process control valve outlets are sealed off, the fans are off, and no unfiltered air can leave the WV. This mode is also used for experiments not requiring air circulation in the WV.

As shown in Fig. 5, the MSG facility has three filter banks. Each filter bank has a set of four parallel front filters on a front filter plate and a set of four parallel rear filters on a rear filter plate. The rear filters provide a backup filter system. Each front filter consists of four basic elements arranged in a specific order. These is a wire mesh which serves as a barrier for flame propagation, High-Efficiency Particle Air (HEPA) filter elements

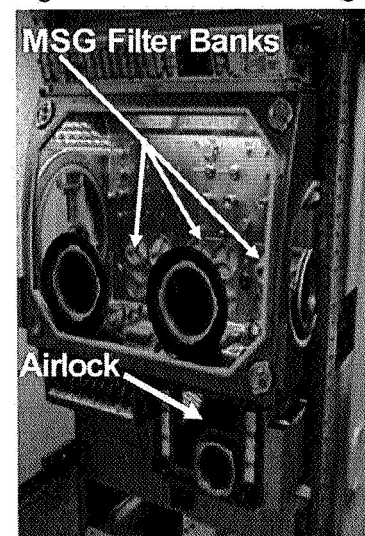

Figure 5. MSG Filter Banks.

for particle filtration down to 0.3 micron size, an activated carbon element for adsorbing solvents, chemicals and gases, and a monolith element for oxidizing combustion products like carbon monoxide. The rear filter is redundant with the front filter in its ability to filter organic solvents and convert carbon monoxide, there is no HEPA installed in the rear filters. The MSG air circulation system can provide up to 200W of cooling.

#### **I. Illumination**

Three identical illumination units in the top of the WV provide the illumination of the working area. The three illumination units combine to provide 1,000 Lux maximum illumination at approximately 200 mm above the center of the WV floor. The general illumination is variable in intensity. At the maximum intensity the color temperature is  $> 2,750$  K, with color rendering index (RA) of 85 or better. The Airlock illumination provides 323 Lux general working light. The illumination units can be switched on and off manually by the crew or remotely from the ground.

#### **J. Airlock**

The airlock, shown in Fig. 5, is a box-like structure attached to the bottom plate of the WV with an allowable work area of approximately 26 liters. There is no active thermal conditioning in the airlock. The airlock temperature is ambient, air circulation provides conditioning of the airlock atmosphere only. Airlock illumination can be switched on and off manually or remotely. The airlock front door provides a Lexan Window and a glove port. The front door can be fully removed for ease of loading investigation hardware with the dimensions of 254mm (10") by 343 mm (13.5") by 299 mm (11.7"). The Airlock top lid in the WV contains 18 M6 inserts on a 70 x 70 mm grid for threaded fastener hardware mounting. The Airlock top lid can be removed completely and can be locked to create a leak tight airlock connection. The topside of the airlock lid is equipped with a removable handle for the actuation of the locking mechanism. When the handle is removed a complete flat surface is available for use inside the WV. An oven-like concept is used inside the airlock to allow for ease in payload transfer from the airlock to the WV. The concept consists of a tray, which can be placed at two different heights or completely removed from the airlock. The tray is equipped with seven bungee cords for attaching payloads. The filter used in the airlock is the same type as used in the WV. Power is not available for experiments inside the airlock. The temperature and humidity of the Airlock is monitored and is available in the MSG downlink data. Fig. 5 shows the location of the airlock on the bottom right corner of the MSG work volume.

#### **K. Available MSG Facilities**

The MSG program hardware consists of an operational Flight Unit on-board the International Space Station, a high fidelity training unit at the Johnson Space Center (JSC), a ground unit at the Marshall Space Flight Center (MSFC), and a flight equivalent engineering unit at MSFC. The ground unit is functionally equivalent to the flight unit and is available to researchers for development testing and fit checks. The engineering unit is identical to the flight unit and is used to fully verify experiment compatibility prior to flight. In addition, the engineering unit is available for troubleshooting of in-flight anomalies during flight operations. The MSG program also provides researchers with a flight like A31P laptop computer as resources allow.

A telescience center at MSFC provides researchers a link to interact with the experiment during flight operations. The investigator can be located at either MSFC or their home laboratory, where they are connected via communication links. The entire communication loop from the telescience center to the payload in the MSG can be simulated using the MSG engineering unit and the telescience facilities at MSFC. This allows for a thorough check out of payload hardware, software, and communication systems prior to flight and affords the researcher a high degree of confidence that the planned experiment will be successful in orbit.

### **III. Overview of the Research Accomplished in the MSG Facility to Date**

To date, the MSG facility has logged over 3000 hours of on-orbit operations processing 14 investigations. Areas of science that have benefited from experiments in the MSG include, fluid physics, materials science, thermal control, protein crystal growth, and technology demonstration. The paragraphs that follow contain a brief synopses of the investigations that have been performed in the MSG.

#### **A. United States Sponsored Investigations**

##### ***Solidification Using a Baffle in Sealed Ampoules (SUBSA)<sup>1</sup>***

One of the first materials science experiments on the International Space Station – the Solidification Using a Baffle in Sealed Ampoules (SUBSA) investigation was conducted during Expedition 5 inside the Microgravity Science Glovebox. SUBSA was the first experiment to operate in the MSG facility on the International Space Station.

The main objective of the SUBSA investigation was to improve science's understanding of the formation of semiconductor crystals. Semiconductor crystals are used for many products such as computer chips, integrated circuits, sensors for medical imaging equipment, and detectors of nuclear radiation.

To control the opto-electronic properties of the semiconductor crystals, a small amount of an impurity — named a dopant — has to be added to the pure semiconductor. Uniform distribution of the dopant in the semiconductor crystal is essential for production of opto-electronic devices.

For the SUBSA investigation, tellurium and zinc were used as dopants in an indium antimonide sample. The samples were heated to 850 degrees Celsius and then directionally solidified to form a solid single crystal. The SUBSA samples were loaded in clear quartz ampoules and the SUBSA thermal chamber had a transparent gradient zone which allowed the entire process to be captured on video. Indium antimonide was selected because of its low melting point of around 525 degrees Celsius and because it is useful for creating models that apply to a variety of semiconductors. During processing, the scientist was able to observe the down linked video images and command the furnace from the telescience center at the Marshall Space Flight center to position the solid/liquid interface in the most optimum position prior to the start of directional solidification. This unique capability, provided by the MSG facility, allowed the scientist to optimize the investigation real time, and maximize the scientific return.

The SUBSA investigation was setup on-orbit by Astronaut Perry Whitson and completed operation in October 2002 as part of Expedition 5.

##### ***Towards Understanding Pore Formation and Mobility During Controlled Directional Solidification in a Microgravity Environment (PFMI)<sup>2</sup>***

The PFMI investigation sought to improve science's understanding of solidification processes and the effects of imperfections in the molten material. On Earth when scientists melt metals, bubbles that form in the molten material can rise to the surface, pop and disappear. In microgravity, the lighter bubbles do not rise and disappear. Prior space experiments have shown that bubbles often become trapped in the final metal or crystal sample. In the solid, these bubbles, or porosity, are defects that diminish both the material's strength and usefulness.

The Pore Formation and Mobility Investigation melted samples of a transparent modeling material, succinonitrile (SCN) and succinonitrile water mixtures. The transparent material allowed scientists to observe how bubbles form in the samples and study their movements and interactions.

The PFMI experiments heated the SCN samples to approximately 120 degrees Celsius and directionally solidified them at translation velocities of 0.5 micrometers per second up to 10 micrometers per second. Two cameras were used to collect real-time images of the samples as they were melted and subsequently resolidified in the thermal chamber.

Images were sent to the investigator on the ground working in the telescience center at Marshall Space Flight Center. The investigator manipulated the investigation by sending commands to change temperatures, growth rates and other variables that affected sample processing.

The PFMI investigation has processed over 20 samples in orbit and continues to operate on board ISS at this time.

##### ***Investigating the Structure of Paramagnetic Aggregates from Colloidal Emulsions (InSPACE)<sup>3</sup>***

The InSPACE investigation examined the way small magnetic particles interacted with the complex properties found in magnetorheological fluids. Magnetorheological (MR) fluids are a class of "smart" materials capable of providing a rapid, controllable response when a magnetic field is applied. The low-gravity International Space



Station environment allowed research on particle interaction without the effects of sedimentation. An objective of the InSPACE investigation was to determine the true three-dimensional low-energy structure of a MR emulsion in a pulsed magnetic field. The InSPACE investigation visually studied the final, fine structure of the MR fluid in a pulsed magnetic field. This study helped researchers understand the competing forces that govern the final shape of the structures.

The InSPACE hardware consisted of five major parts: the Helmholtz coil assembly containing the sealed vial that holds the MR fluid; an optics assembly with two long working-distance lenses, cameras, and base plate; an avionics assembly containing two displays, a square-wave generator, and the power distribution box; the light source assembly; and three video recorders, which are part of the Microgravity Science Glovebox (MSG). The crew inserts the coil assemblies into the optics plate. The square-wave generator then sends pulsed power input along the Helmholtz coil, generating a magnetic field in the fluid. The cameras, equipped with microscopic lenses, record the activities of the fluid microstructures with and without the magnetic field.

InSPACE was operated by Astronaut Don Pettit as part of Expedition 6.

### ***Coarsening in Solid Liquid Mixtures-2 (CSLM-2)***<sup>4</sup>

CSLM-2 is a materials science experiment designed to study the rate at which particles of tin suspended in a liquid comprised of molten tin/lead alloy, increase in size, a process called coarsening.

CSLM-2 used the microgravity environment on the ISS to prevent the tin particles from rising to the top of the mixture as well as to eliminate convection in the tin/lead mixture, which can influence coarsening.

In any mixture that contains particles of different sizes, the large particles tend to grow while the smaller particles shrink in a process called coarsening. Tiny oil droplets coalescing into a large blob are one illustration, but the process occurs in solids as well. Coarsening occurs on Earth during the processing of any metal alloy and thus the coarsening process affects products from dental fillings to turbine blades. Since the properties of an alloy are linked to the size of the particles within the solid, coarsening can be used to strengthen materials. This is the case with the majority of aluminum alloys used commercially today. Conversely, if the coarsening process proceeds too long the material can weaken. This occurs in jet turbine blades and is one of the reasons why turbine blades must be replaced after a certain number of hours of service. Thus developing accurate models of the coarsening process is central to creating a wide range of new materials from those used in automobiles to those used in space applications. The results of previous experiments performed on the Shuttle have done just that. These models have been incorporated into a computer code that is being used to design many new materials, including materials of importance to NASA's spaceflight program. Solid-liquid systems are ideal systems to study this coarsening process. However, gravity can induce particle sedimentation and thus hamper the studies of coarsening in these mixtures on Earth.

The CSLM-2 investigation intended to use the microgravity environment of the Space Station to study the process of coarsening with reduced interference from the sedimentation that occurs on Earth. However, due to the Columbia disaster, samples from CSLM-2, were not able to be returned to Earth in time for evaluating the results. Although the data was lost, engineering data collected on equipment function can benefit subsequent experiments.

## **B. European Space Agency Sponsored Investigations**

Since the inception of the MSG program, ESA has developed and operated eight successful investigations in the MSG facility. Four experiments were developed by ESA as part of the Belgian Taxi Flight (BTF). The investigations included COSMIC, DCCO, Nanoslab, and PromISS-1. This series of experiments were a part of the science research activities performed in November 2002 aboard the ISS by Frank de Winne, ESA astronaut of Belgian nationality. Nanoslab encountered technical difficulties and was not able to complete all of the scientific objectives.

In October 2003, Spanish astronaut, Pedro Duque, performed MSG investigations Nanoslab and PromISS-2 as part of the Spanish Soyuz Mission. The Nanoslab investigation was a follow on to the Nanoslab investigation that encountered technical difficulties during the Belgian Taxi Flight. Duque spent eight days aboard the Space Station conducting science experiments under a commercial contract between ESA and the Russian Aviation and Space Agency.

In April 2004, MSG investigations HEAT and ARGES were operated as part of the Dutch Soyuz Mission. The experiments were performed by Dutch ESA cosmonaut / astronaut André Kuipers who was launched to ISS from the Russian launch site Baikonur on April 19<sup>th</sup>, 2004.

A 30 day PromISS-3 investigation was performed in January and February of 2004. Other PromISS investigations are planned for future operations in the MSG. This illustrates the usefulness of the MSG facility. The

primary investigation hardware remains on-board and future investigations require relatively little up mass to deliver new samples for follow on experiments.

The following paragraphs provide a brief summary explanation of these ESA investigations. For more detailed information concerning these investigations, please refer to the European Space Agency web page at <http://www.esa.int>.

#### ***Combustion Synthesis under Microgravity Conditions (COSMIC)<sup>5</sup>***

COSMIC studied microstructure formation of compressed powder samples (in casu Ti-Al-B) during self-propagating high-temperature combustion processes (SHS). The main scientific objective was the investigation of the relationship between general physico-chemical mechanisms of combustion and formation of the microstructure and composition fields. The COSMIC experiment was a part of the science research activities performed aboard the ISS by Frank de Winne, ESA astronaut of Belgian nationality in the frame of the ODISSEA Project. The European Space Agency and Belgian Federal Office for Scientific, Technical and Cultural Affairs (OSTC) were responsible for preparation and implementation of the scientific program.

#### ***Microgravity Experiment For the Measurement of Diffusion Coefficients in Crude Oil (DCCO)<sup>6</sup>***

This research program aims to investigate the isothermal diffusion and the Soret effect (thermodiffusion). The scientific community and petroleum industries have a great interest in the accurate measurements of diffusion and Soret coefficients. The DCCO experiment objective was to measure diffusion coefficients of ternary mixtures of organic compounds. The experimental data set included different liquid mixture mass fractions. The mixtures were composed of n-dodecane, tetrahydronaphthalene and isobutylbenzene that are compounds representative of the crude oil chemical families. The principle was to introduce liquid A into a column of the ternary mixture B by removal of a slider gate. During the three to five hours-expected diffusion duration, the process was monitored with a dual wavelength Mach-Zehnder interferometer, measuring the change in refractive index induced by concentration gradients. From the resulting interferograms recorded on a photo camera, the concentration gradients are derived as a function of time. The DCCO experiment was performed by Belgian astronaut Frank de Winne as part of the Belgian Taxi Flight.

#### ***NANOSLAB<sup>7</sup>***

NANOSLAB is physical sciences investigation involving zeolites. Zeolites are crystal formations with structured spaces or pores that allow them to absorb or hold onto other materials such as water. The NANOSLAB research has significance in areas including the petrochemical industry. The aim of this experiment is to try and create more effective zeolite crystal structures by mixing different zeolite solutions with a range of crystal-forming catalysts. The NANOSLAB experiment was conducted by Spanish astronaut Pedro Duque as part of the Spanish Soyuz Mission.

#### ***Protein Microscope for the International Space Station (PromISS-1,2 & 3)<sup>8</sup>***

The PromISS investigations are a study of the crystallization of proteins in microgravity conditions. These investigations seek to provide information that will lead to a better understanding of the fundamental processes underlying the protein crystallization process. The major objective of the experiments is to produce a detailed analysis and quantitative interpretation of the relationship between the quality of the crystals and the environment in which they were produced. The objectives are to:

- Further evaluate the effect of microgravity on crystal quality, as compared to experiments in gel.
- Confirm that the removal of convection by the use of gels has a similar effect as microgravity
- Quantify the relationship between position of growth of the crystal and crystal quality.

The PromISS investigation uses a Digital Holography Microscope to analyze the crystallization process. The PromISS-1 experiment was performed during the Belgian Taxi Flight in November 2002. Preliminary results obtained show that the instrument was strongly affected by vibrations and the temperature profile of the mission. These factors had a bad impact on the quality of the results obtained.

An upgraded version of the PromISS-1 hardware, called PROMISS-2 was uploaded with Progress 11P in August 2003 and operated as part of the Spanish Soyuz Mission (SSM). Six PROMISS experiment cells were uploaded with the Soyuz 7S, analysed with the PROMISS-2 optical diagnostic hardware over 10 days, and downloaded with the Soyuz 6S.

The PromISS-3 experiment was a re-flight of the previous PromISS-2 experiment performed during the Spanish Soyuz Mission, but with an investigation of the experimental cells in the Digital Holography Microscope of 30 days. After the 30 day processing, the samples were stowed in an incubator (AQUARIUS) for 2 months, and then returned on Soyuz 8S. The PromISS-3 experiment is an adaptation of a digital holography instrument developed by ULB-MRC for the observation of counter-diffusion experiments in microgravity. This instrument provided a view of the crystallization reactions in terms of density gradients in the solution and of the localization of the crystals. The observation of the density gradients should make it possible to evaluate models of the diffusion and residual convection in the crystallization process. This information, together with the localization of the crystals, and the observation of the timing of their growth, can allow the identification of the growth conditions of the crystals. This information can then be related to crystal quality and internal order.

#### ***Heat transfer performance of a grooved heat pipe (Heat)<sup>9</sup>***

Heat was an investigation of the effectiveness of grooved heat pipes in the weightlessness of space. The main aims of this technology demonstration were ;

- The characterization of the heat transfer performance of a grooved heat pipe in weightlessness, by measuring the maximum rate of heat flow sustainable in three different modes:
  - Anti-parallel heating/cooling (i.e. heating from one side of the pipe then cooling from opposite side).
  - Mixed heating/cooling conditions (i.e. heating from two sides of the pipe then cooling from one of these sides)
- The validation of the existing mathematical model that is used to evaluate the performances of new heat pipes.
- To prove that the grooved heat pipe design can cope with the formation and trapping of vapor bubbles in the pipe. A build up of vapor on the inner surface of a pipe creates an insulating layer, which reduces the pipes effectiveness to transfer heat.

The Heat investigation was performed in April 2004 as part of the Dutch Soyuz Mission.

#### ***ARGES Investigation -- Energy efficient lamps for the future<sup>10</sup>***

The ARGES investigation sought to improve the understanding of High-Intensity Discharge (HID) lamps and how they are affected by imperfections. The ARGES experiment examined these HID lamps in the microgravity environment of the International Space Station.

The ceramic container of a HID lamp holds several metal gasses, sealed under high pressure. If a powerful electrical current runs through the gaseous content, the metal atoms in the gas pick up energy and radiate light. However, over time the gaseous contents begin to de-mix or separate away from each other. As a consequence not every part of the lamp has an equivalent amount of energy to transfer into light.

Instable plasma channels and de-mixed gasses are the two biggest problems in HID lamps. Therefore, the main objectives of the ARGES experiment were to determine, which factors were causing these two problems. To do this, the ARGES investigation employed a high-resolution emission spectrometer to analyze a series of individually lighted HID lamps. Each light-producing gas in the HID has its own spectrum. The emission spectrometer was used to determine, which gases were present in small areas within the lamp.

Like the Heat investigation, the ARGES investigation was performed in April 2004 as part of the Dutch Soyuz Mission.

### **IV. Future MSG Investigations**

The many capabilities of the MSG detailed in this paper, make it an ideal platform for research required to advance the technology readiness levels (TRL) needed for the Crew Exploration Vehicle and the Exploration Initiative. Related areas of research that will benefit from investigations in the MSG include combustion, fluids physics, thermal control, fire suppression and detection, in situ fabrication and repair, material science, and life sciences. Investigations currently planned for operation in the MSG include BXF, SAME, ZBOT, SODI, MFEU, and Micro Fluidic. The following paragraphs provide a brief overview of MSG investigations that are planned for operation in the next two years along with some suggestions for other future MSG investigations.

## **A. Investigations Planned for Near Term Operation in the MSG Facility**

### ***Boiling eXperiment Facility (BXF)*<sup>11</sup>**

The BXF investigation will obtain data needed to understand the process involved with boiling in gravity and microgravity. The research should enable the development of more efficient cooling systems on future spacecraft and on Earth.

Boiling efficiently removes large amounts of heat by generating vapor from liquid. It is being used in electric power plants, electronic cooling and purification and separation of chemical mixtures. An upper limit, called the critical heat flux, exists where the heater is covered with so much vapor that liquid supply to the heater begins to decrease. Supplying constant power above this limit for prolonged periods can increase the heater temperature to the point whereby the heater is destroyed. Determination of critical heat flux in microgravity is essential for designing cooling systems for space. Therefore, boiling is being studied to increase the effectiveness of cooling in space.

The Boiling eXperiment Facility (BXF) will house two separate investigations, BXF-MABE and BXF-NPBX. The purpose of the BXF is to validate models being developed for heat transfer coefficients, critical heat flux and the pool boiling curves.

### ***Smoke Aerosol Measurement Experiment (SAME)*<sup>12</sup>**

The SAME investigation is being developed by the NASA Glenn Research Center, ZIN Technologies, and the National Institute of Standards and Technologies (NIST). The SAME experiment is designed to determine the particle size distributions of the smokes generated from a variety of overheated spacecraft materials and from microgravity fires. The objective is to provide the data that spacecraft designers need to properly design and implement fire detection in spacecraft. This investigation will also evaluate the performance of the smoke detectors currently in use aboard the space shuttle and ISS for the test materials in a microgravity environment.

### ***Zero Boil- Off Tank Experiment (ZBOT)*<sup>13</sup>**

The ZBOT investigation will improve the scientific understanding of the storage of cryogenic fluids in low gravity conditions. Effective, affordable, and reliable cryogenic fluid storage is essential for propellant and life support systems on interplanetary spacecraft. The Zero-Boil-Off (ZBO) approach is an innovative means of controlling storage tank pressure by eliminating tank self-pressurization through a synergetic application of passive multilayer insulation, an active heat removal system, and a forced mixing mechanism. ZBOT will result in design guides for cryogenic fluid storage tanks and a database of microgravity fluid management data for specific in-orbit or on surface applications. The end goal is to deliver cost-effective, reliable, and enabling design concepts for long-term storage of cryogenic fluids used in life support and propulsion.

The technology to be developed applies equally to short duration (50-100) day storage applications for the envisioned 2010-2015 missions to the earth's neighborhood and to long duration 100-1000 days interplanetary missions beyond 2015. Consequently ZBOT will encompass both microgravity storage in low and high earth orbit and reduced gravity storage on the lunar, Martian or other planetary surfaces.

### ***Critical Velocities in Open Capillary Channels (CCF)*<sup>14</sup>**

The CCF Experiment refers to a versatile experiment program for studying an important variety of inertial-capillary dominated flows that are of basic interest in fluid physics and at the same time key to certain space applications, but cannot be studied on the ground. Applications of the results are directed to the portion of the aerospace community challenged by the containment, storage, and handling of large liquid inventories (fuels, cryogenics, water) aboard spacecraft. The results are expected to be immediately useful for the design and testing, and instrumentation for verification and validation of liquid management systems of current orbiting, design stage, and advanced spacecraft. The results will also be useful to improved life support system design, phase separation, and enhancing current system reliability by designing into the system passive (in this case 'capillary') redundancies.

### ***Smoke Point in Coflow Experiment (SPICE)*<sup>15</sup>**

The Smoke Point in Coflow Experiment (SPICE) will observe nonbuoyant round laminar jet diffusion flames in air coflow at standard temperature and pressure (STP) to:

- Determine the effects of fuel type, burner diameter and coflow velocity on smoke point properties.
- Identify test conditions for closed- and open-tip smoke point behavior and resolve mechanisms of these transitions.

- Determine the effect of fuel type, burner diameter, and approach to the smoke point on luminous flame shapes.
- Develop and evaluate models of soot formation, luminous flame shapes and flame radiation.

Data to be obtained from SPICE include video of flames, digital photographs of flames, radiometer output, fuel flow velocity, fan voltage, and coflow air velocity.

### ***Selectable Optics Diagnostics Instrument (SODI)<sup>16</sup>***

The SODI hardware is being designed by the European Space Agency (ESA) to operate in the MSG facility and accommodate the Diffusion and Soret Coefficients (DSC) measurement investigation, the Influence of Vibration on Diffusion in Liquids (IVIDL) investigation, and the Aggregation of Colloidal Solutions (COLLOID) investigation. The objective of this series of investigations is to;

- Study diffusion and Soret phenomena and measurement of these coefficients in multi-component mixtures (liquids).
- Study the influence of controlled vibration stimuli on these diffusion processes.
- Study the aggregation (clustering) of colloidal solutions.

The instrumentation will employ several optical diagnostic methods including;

- Mach Zehnder interferometry (MZI)
- Digital Holographic Microscopy (DHM)
- Near Field Scattering (NFS)
- Particle Image Velocimetry (PIV)
- Photogrammetry (PM)

These methods will be used to analyze a selection of liquids and gases in the microgravity environment.

### ***Magnetic Fluids Experiment Unit (MFEU)<sup>17</sup>***

The MFEU investigation is designed to study heat and mass transfer phenomena in suspensions of magnetic nanoparticles under the influence of variable temperature gradients and magnetic fields on different geometries. The experiments will involve liquid ferrofluids in a cylindrical gap. The ferrofluids will be exposed to controlled magnetic fields provided by toroidal coils. Cylindrical internal and external water heat exchangers will provide temperature differences in the radial direction while the surface temperature at the outside wall of the magnetic fluid layer will be maintained constant. Temperature gradients will be measured by thermistors and optical observation of a temperature sensitive liquid crystal layer.

### ***MicroFluidic Light Experiment<sup>18</sup>***

This ESA developed investigation will test the use of innovative micro fluidic devices which are the core element of miniaturized medical diagnostic systems. The experiment will involve a series of micro-fluidic chips in a light box that will be attached to one of the MSG cameras. Each of the chips will be injected with a photoshate buffer saline fluid with suspensions of fluorescent polystyrene micro beads. The MSG cameras will be used to observe transport of fluid through the chip by capillary forces. Images will be saved on the MSG laptop computer and down linked to the science team on the ground.

## **B. Other Potential Exploration Related Investigations that can be Accommodated by The MSG Facility**

When President Bush announced a New Vision for Space Exploration on January 4, 2004, he said:

“Research on board the station and here on Earth will help us better understand and overcome the obstacles that limit exploration. Through these efforts we will develop the skills and techniques necessary to sustain further space exploration.”

As the President mentioned in this quote, our knowledge of key technologies must be improved if we are to meet NASA’s current exploration goals. To do this, we must perform research in an environment similar to the one that our spacecrafts and crew members will actually experience during space travel. As discussed in this paper, the MSG

facility is a very capable and versatile resource that is available in the microgravity environment on the International Space Station to perform this type of research. Much of the work needed to advance key technologies is already underway. In fact, many of the papers published at the 45th AIAA Aerospace Sciences Meeting and Exhibit in January 2007, involve analytical techniques and technologies that could possibly benefit from performing experiments in the MSG facility in the reduced gravity environment of the ISS. The authors of this paper wish to encourage all Scientist and Engineers who are performing research in the Space environment to make an investigation in the MSG facility a part of their development plan.

## V. Possible enhancements to the current MSG baseline configuration

Within Europe, the European Space Agency (ESA) and Bradford Engineering BV (developer and manufacturer of STS, MIR and ISS gloveboxes) have recently set-up a Glovebox Technology Center which has the following goals:

- to present all potential scientific utilization of the Gloveboxes to (scientific) user-groups,
- to share the acquired utilization knowledge with new users
- to support easy access to well maintained Glovebox models for experiment assessment and check-out
- **to support development of new technologies aimed at upgrading the existing facilities.**

The Glovebox Technology Center (GTC) is centered around 4 pillars:

- Expertise Keeping
- **Future Support Items Development**
- Marketing
- Experiment/Spares support

Scientist and engineers from this community have recommended some potential enhancements to improve the usability of the Microgravity Science Glovebox (MSG). These enhancements include the following;

1. Additional cooling capacity for experiments
2. Life Science Glovebox filter technology for MSG
3. Sterilization capability based on ozone technology
4. Centrifuges (inside Airlock or inside WV)
5. Incubator, Peltier controlled, cooling and heating (inside Airlock)
6. Furnish, IR or microwave controlled (inside Airlock or inside WV) Diagnostic instruments (inside WV) to enable direct feedback of experiment results, which offers a more dynamic and efficient way of testing, e.g. microscope, X-ray equipment.
7. Standard provided additional sensor capabilities for experiments inside WV, e.g. temperature sensors, oxygen sensor with data acquisition through ECB.

This paper is limited in describing the first three subjects, which Bradford Engineering BV believes are the most promising and realistic ideas to be investigated and realized in the short term.

**1 - Enhanced Cooling Capacity Concepts for MSG Experiments**

This chapter describes thermal pre-analysis/proposal, which defines a possible MSG thermal hardware upgrade. It addresses only to the thermal condition of MSG Experiment Payload and will review the possibilities to expand temperature range and increase the thermal power dissipation of Experiments. The Thermal Control Sub-System of MSG Work Volume has two elements (WHX and WCP) as shown on the figure below.

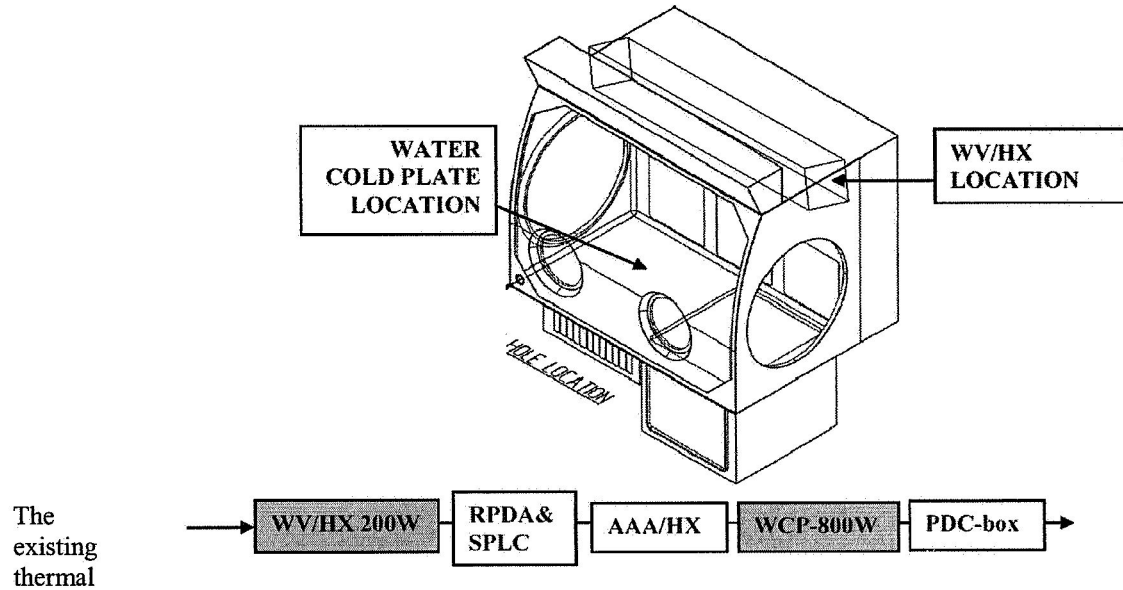

limitations (current baseline) for MSG Experiment Payloads are:

- The total allowed experiment power dissipation is  $\leq 1000$  W
- The maximum allowed to the WV Air Power dissipation  $\leq 200$ W
- The maximum allowed Power dissipation via thermal contact with Water CP is  $\leq 800$ W
- The actual achieved minimum CP water inlet temperature is 26-28°C.
- Note: there are no possibilities to provide experiment at temperature level  $< 0^\circ\text{C}$  without additional thermal hardware units.

The purpose of proposed MSG modification is to expand experiment possibilities, in particular

- To increase the total power dissipating from the experiment within the MSG WV
- To increase the maximum experiment power dissipation to the WV-air
- To increase the maximum experiment power dissipating to the Water Cold Plate
- To expand the temperature range for MSG experiments and to provide possibilities for low temperature experiments.
- To provide constant surface temperature control (cooling/heating)

Twelve suitable technical solutions are proposed and described in a BE Technical Notes with reference, MSG-BE-TN-0055 and 0056. The three preferred solutions are highlighted in this chapter.

Solution-2.

The existing MSG WCP will be applied together with additional MSG Work Volume Cold Plate (AWCP). In this case the experiment will have two contact surfaces for power dissipation. Flow distribution between two CPs will be adjusted to provide the best condition for the Experiment. The expected allowed Payload Power can be between about 1200 – 2000W (800 WCP +1200AWCP).

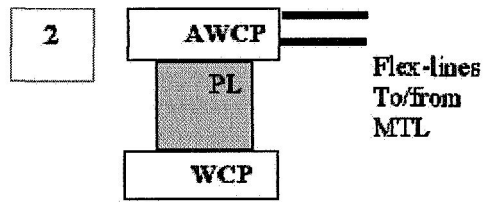

**Solution 4**

In this case the Thermo Electrical Unit application is stipulated. Peltier Elements will decrease the temperature of the contact surface exposed to the Payload. The hot-surfaces of Peltier's will have thermal contact with the WCP. Several contact surfaces are necessary to provide suitable TEU design, which will reduce the Peltier efficiency. The expected cooling capability of the TEU is 300-400W @ 16-25°C temperature level of contact surface and at dissipated 700-900W heat power on the WCP contact surface.

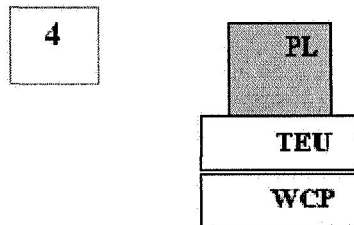

Why is the TEU application necessary? Because if we route 300W directly to the WCP, its surface temperature will increase up to 37°C temperature. Thus, to have 18°C temperature level (@300W Payload Power) on the Experiment contact surface will cost about 500W electrical power.

The following data have been measured on the actual MSG Flight Unit WCP.

Case-A, MTL Water Flow	89 kg/hr
CP Payload/Heater Power	816W (692W is dissipating in water)
Water temperature outlet/inlet	36.1/29.5°C
CP Surface temperature sensor	49.5°C
Case-B, Water Flow	130 kg/hr
CP Payload/Heater Power	816W (710W is dissipating in water)
Water temperature outlet/inlet	29.0/24.3°C
CP Surface temperature sensor	41.6°C

The actual achieved minimum WCP water inlet temperature is about 26-28°C and this does not provide the low (moderate) temperature level required by some potential MSG Experiment Payloads.

The proposed TEU can shift the temperature of (Low Power) MSG Experiments to the range 15°C - 25°C.

Taking into account the limitation of WCP water outlet temperature, the maximum Power dissipation of TEU shall not exceed 800W. That will define in turn the limitation of the TEU cooling capability, because sum of the consumed electrical power and cooling capability will be the heat load into the WCP.

The expected TEU cooling capability limit is about 300-400W (TBC). If Payload requires more power dissipation, it will be more effective to install the Experiment Payload directly to the WCP. The appropriate recommendations will be done after TEU thermal performance test.

For different Payload Power dissipation the TEU contact surface will have different temperatures. For High Power experiments (>400W) it is more effective to install the Experiment Payload directly on WCP contact surface. To explain these phenomena two characteristics have been calculated:

- TEU contact surface temperature as function of Payload Power
- WCP contact surface temperature as function of Payload Power (if Payload directly dissipates heat power to the WCP)



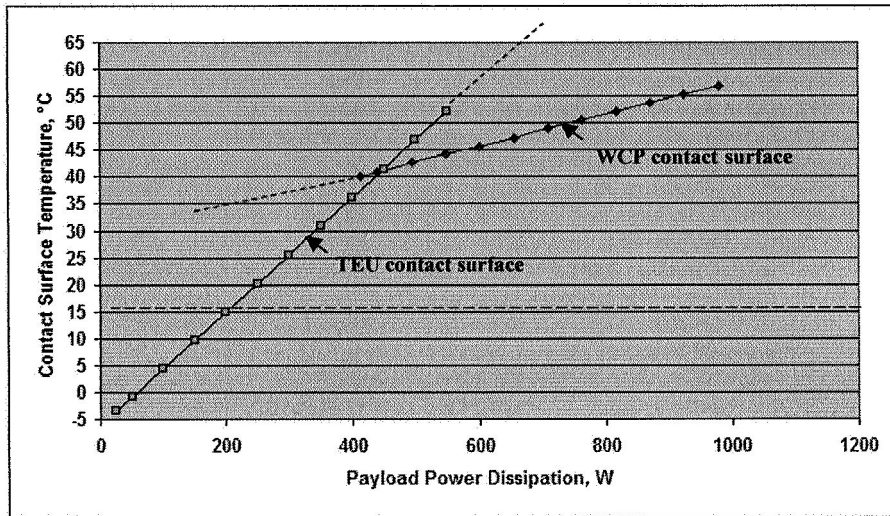

This figure depicts the calculation result. The cross-point on the diagram shows maximum Payload Power which can be dissipated by means of TEU (about 450 W TBC). If the Payload power dissipation is greater than approximately 450 W as shown by the diagram, the payload should be mounted directly to the WCP.

Solution 9, 10, 11, 12

An Air Heat Exchanger (AHX) application is reviewed here. WV Air could be cooled with TEU, AHX-AWCP or with Air -Water Heat Exchanger. This would allow a payload to have a lower ambient air temperature for heat dissipation. For solution #12 the Air Heat Exchanger having contact surface could be applied to decrease Experiment payload temperature, because WV air can have lower temperature potential than the CP contact surface. For this application the Air Heat Exchanger (AHX) is directly connected with Payload. For all cases presented in this paper, cases #9-#12, the Fan - application is stipulated. It can be low-pressure head fan's, but some safety-mesh at the fan's inlet must be included in the design. Assumed additional heat power, which will be dissipated to the WV-air is 50-200W (depending on temperature level of cooling media/surface).

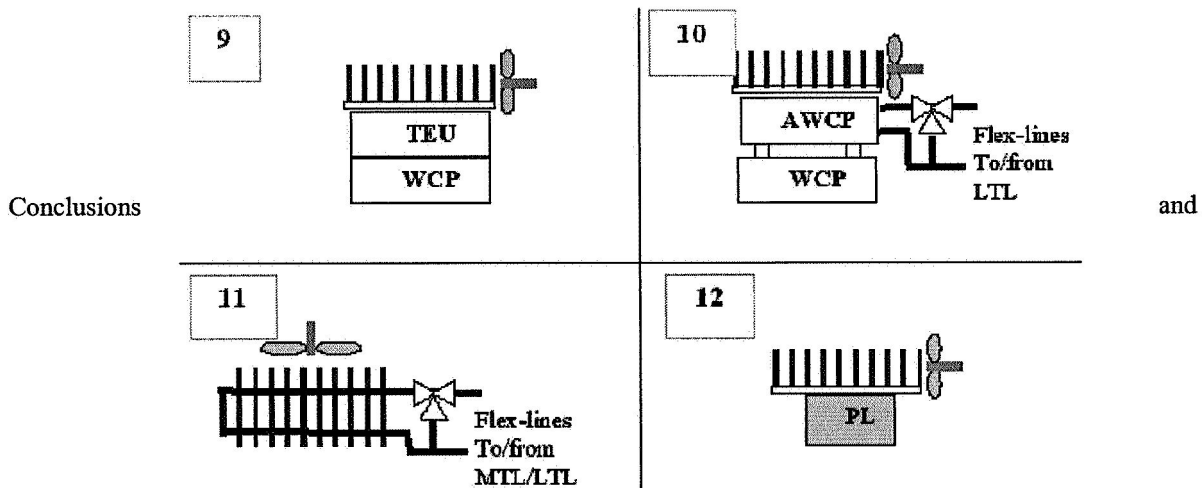

recommendations for the Enhanced Cooling Capacity Concepts for MSG Experiments:

Three additional thermal units could be developed and manufactured to provide an enhanced wide range of MSG Experiment application, these units are:

- AWCP (see Solution 2)

- TEU (see Solution 4)
- AHX / AWHX (see Solution 9/12)

The following characteristics improvement is expected:

- Power dissipation Increasing to the air is 100-200W
- Power dissipation Increasing to the WCP/AWCP is  $\Delta$  800-1200W
- Experiment Contact surface decreasing to 20°C @ 300W Power
- Experiment Contact surface decreasing to 0°C @ 0W Power

Each additional thermal unit could be applied independently or in combination with another unit and that gives a possibility to develop and manufacture each unit independently (sequentially).

## 2 - Life Science Glovebox Filter Technology for the Microgravity Science Glovebox

Maintenance and continuous improvement of the Glovebox capabilities is of essence to maintain a well performing and state of the art set of Glovebox instruments on the ISS. These instruments support a variety of science fields as shown in the table below:

Instrument	Main science application area	Remark
Microgravity Science Glovebox (MSG)	Fluid, combustion and general physics	Filters physically compatible with BGB and PGB
Biological Glovebox (BGB) as part of BioLab	Cell biology	Filters physically compatible with MSG and PGB
Life Sciences Glovebox (LSG)	Animal and plant research	State of the art dedicated, large capacity filters
Portable Glovebox (PGB)	General containment support	Filter physically compatible with BGB and MSG

MSG has been operational in the ISS since 2002 and the PGB since 2006, the BGB will become available with the launch of Columbus in 2007. LSG was foreseen to be launched in 2008, but unfortunately this program was cancelled. The fact that LSG won't be part of the ISS utilization anymore must have an impact on the foreseen life science research.

Against this background, Bradford engineering BV has reviewed its design of MSG and LSG in terms of materials used and air filtration to determine if (even limited) MSG could be used for LSG type experiments.

From a materials point of view, MSG and LSG use the same materials for the workvolume and internal air loop. For filtering, the picture is quite different. MSG uses a front and rear filter system and has no fresh air supply. The MSG front filter contains (in the direction of flow) a HEPA, Charcoal and catalyst. The MSG rear filter duplicates this capability except for the HEPA. The LSG filters also have the HEPA but then use a maximized active charcoal bed (impregnated charcoal) dedicated to absorb/contain typical life sciences fluids/gases. MSG air ducts and the Heat exchanger fins (after the filters) are alodyned whereas the LSG air ducts are nickel plated and the heat exchanger fins are anodized. It is evident that MSG can not directly be used for LSG experiments. In the remainder of the chapter, an approach is outlined to equip MSG with derivatives of LSG style filters and to perform the necessary verifications.

### *Design and Development Approach*

In principle two possibilities exist to implement LSG filter capabilities in the MSG environment. The first option is to blindly replace the MSG front filters and copy the square LSG charcoal beds into the MSG workvolume (WV) and to develop interconnecting ducting to the bayonet MSG filter interfaces. This however, will take serious amounts of space from the WVe and will result in completely different flow conditions for the MSG WV (both flow pattern and flow rates). A more viable option is to adopt the same active charcoal as used for the LSG filters and then to develop a MSG style filter (cylinder) based on scaling of the LSG flow conditions. This will also allow LSG filter qualification test data to be used for qualification of the modified MSG filter. This approach keeps the same interfaces and only yields a minor protrusion into the WV.

The selected approach is based on the strategy to use, to the maximum extent possible, the existing LSG filter type performance qualification data. A scaling effort is made to determine the length of the MSG Front Filter cylinder such that the same filter characteristics can be achieved. The result will be that MSG can provide the same performance in terms of filtering fluids or gasses, but an effort will be required to verify the filter with respect to MSG flow conditions. This is simply due to the different volume of charcoal and different speed settings for the fans.

For the sake of nomenclature, the MSG filters for life science type applications are called MSG-L (dash L) filters.

*Testing approach*

Once the MSG-L filter is developed, a Filter Adsorption Capability Test will have to be performed. This test is not to demonstrate the ability to filter like the LSG filter (this is provided for by using the same activated charcoal) but to determine the absolute capabilities.

Therefore, the purpose of this test is to clarify the adsorption capability of the MSG-L filter. The verification tests of the LSG Filter were conducted to test whether the filter adsorbs the specific (LSG specified) amount of chemicals. This MSG-L test will be conducted to determine the maximum adsorption capability of the MSG-L filter.

The data received from this test campaign will put forward the strict performance limits of the MSG-L filters. This will provide the scientist with clear figures for the scaling and set-up of his/her experiments.

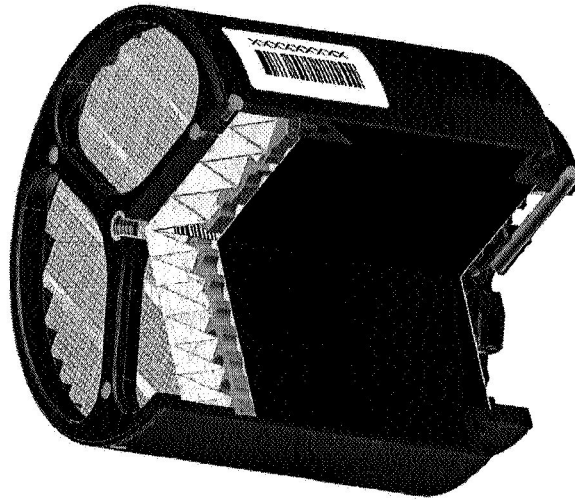

View of proposed MSG-L filter

### ***3 - Sterilization capability (based on ozone technology)***

Bradford Engineering has developed, designed and manufactured the Biological Glovebox; BGB, for the Biolab-Rack inside the Columbus module. One of the features of BGB is sterilization by means of ozone.

Sterilization with ozone has a number of advantages, certainly in space where resources are limited. The sterilization with ozone is done at ambient temperature and a pressure slightly under ambient (3 ~ 5 mbar). Ozone is quickly produced when needed and therefore no storage capacity is required; not to say that ozone in this condition is hardly storable.

To produce ozone only air and electricity are necessary. After use, the ozone returns to oxygen. No extra chemicals and no waste which has to be brought up and down. In space, the cabin air can be used for the production of ozone without any special treatment. Care should be taken to select materials that are ozone resistance.

With normal cabin air an ozone concentration of 1200 PPM is achievable. To give an idea of the sterilization potential of ozone the following bacteria were killed in tests within 20 minutes with air which has an ozone concentration of 1200 PPM:

- Actinobacillus actinomycetemcomitans
- Bacillus atrophaeus
- Escherichia coli
- Streptococcus mutans
- Bacillus stearothermophilus

In addition, spores of bacillus atrophaeus and bacillus stearothermophilus were destroyed in less than 2 hours.

Ozone concentrations higher than 0,2 PPM are dangerous for humans. Therefore, a sterilization system with a high ozone concentration must be well protected. In case of a failure ozone must not be allowed to escape into the cabin air. Ozone has a distinctive odor and an odor threshold of 0,015 PPM, so in case of a leak the crew members will be warned in a very early stage. Besides that, the escaped instable ozone molecules will fall apart and become oxygen again. In the case of a complete failure no catastrophic situation can occur as long as the ozone generator is placed inside the MSG which offers two levels of containment and has active charcoal which acts as a ozone destructor. Nevertheless, with respect to safety, the main question is which ozone concentration level is acceptable. This is a

decisive factor. Not only for which bacteria and/or their spores, in combination with time, can be killed off but also for which materials can be used.

To build a flexible and safe ozone based sterilization unit we see a strong combination with the MSG, a new enhanced Portable Glovebox (PGB-O3) and Sterilization Unit (SU-O3). This combination can be used inside MSG in order to configure a highly safe contained active environment. The SU-O3, PGB-O3, and MSG will offer a sterilization capacity of 20 l and operate with a fixed ozone concentration level of 100 PPM (TBC) and a maximum operating time of 8 (TBC) hours and runs on a 28VDC power outlet.

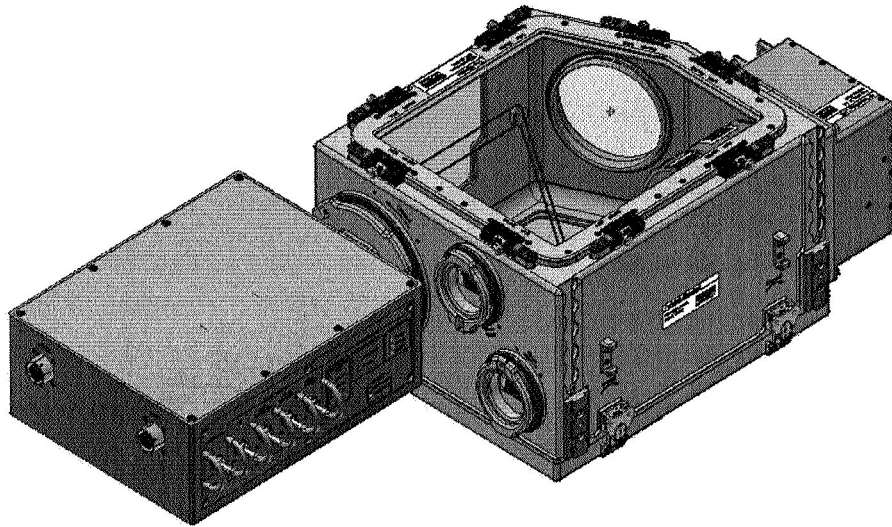

View of proposed PGB-Sterilization Unit

## VI. Conclusion

The Microgravity Science Glovebox (MSG) on the International Space Station (ISS) has been used for a large body of research. The MSG has operated on-orbit for more than 3000 hours performing investigations involving material science, thermal management, protein crystal growth, life sciences, and technology demonstration. The MSG's unique design provides two levels of containment to protect the ISS crew from hazardous operations. Research investigations operating inside the MSG are provided a large 255 liter work volume, 1000 watts of dc power via a versatile supply interface (120, 28,  $\pm 12$ , and 5 Vdc), 1000 watts of cooling capability, video and data recording and real time downlink, ground commanding, access to ISS Vacuum Exhaust and Vacuum Resource Systems, and gaseous nitrogen supply. With these capabilities, the MSG is an ideal platform for space exploration related research. Moreover, the MSG provides engineers and scientists a platform for research in an environment similar to the one that spacecrafts and crew members will actually experience during space travel and exploration. In addition, the facility is ideally suited to provide quick, inexpensive access to space for exploratory type investigations that are necessary to gain an initial understanding of the role of gravity in the physics associated with new research areas. Therefore, the MSG facility is a vital component of NASA's vision for space exploration.

## VII. Acknowledgments

The authors would like to thank the members of the MSG Integration Team for their assistance, and review of this paper. Specifically, Linda Jeter, Andrew Tygielski, Phillip Bryant, Chris Butler, Jeff Smith, Mike Penton, and Frankie Jernigan provided invaluable information and assistance.

## VIII. References

- <sup>1</sup> A. Ostrogorsky, "Solidification Using A Baffle in Sealed Ampoules," AIAA-2003-1309, 41st Aerospace Sciences Meeting and Exhibit, Reno, Nevada, Jan. 6-9, 2003
- <sup>2</sup> Grugel, R., "Toward Understanding Pore Formation and Mobility During Controlled Directional Solidification in a Microgravity Environment (PFMI)," NASA Marshall Spaceflight Center, Huntsville, AL, URL: <http://exploration.nasa.gov/programs/station/PFMI.html>
- <sup>3</sup> Gast, A. P., "Investigating the Structure of Paramagnetic Aggregates from Colloidal Emulsions (InSPACE)," Massachusetts Institute of Technology, Cambridge, MA, URL: <http://exploration.nasa.gov/programs/station/InSPACE.html>
- <sup>4</sup> Voorhees, P., "Coarsening in Solid Liquid Mixtures-2 (CSLM-2)", Northwestern University, Evanston, IL, URL: <http://exploration.nasa.gov/programs/station/CSLM-2.html>
- <sup>5</sup> Froyen, L. "Combustion Synthesis under Microgravity Conditions (COSMIC)," Department MTM, KULeuven, Kasteelpark, Arenberg
- <sup>6</sup> Dubois, F., "Microgravity Experiment For the Measurement of Diffusion Coefficients in Crude Oil (DCCO)," Microgravity Research Center, Université Libre de Bruxelles (ULB), Belgium, URL: [http://www.ulb.ac.be/polytech/mrc/Instruments\\_Design/DCCO\\_en.html](http://www.ulb.ac.be/polytech/mrc/Instruments_Design/DCCO_en.html)
- <sup>7</sup> Kirschhook, C., Kremer S., Martens J., & Pierre J., "NANOSLAB," Centre for Surface Chemistry and Catalysis, K.U. Leuven, URL: <http://www.energia.ru/english/energia/iss/researches/techn-17.html>
- <sup>8</sup> Zegers, I., & Dubois F., "Protein Microscope for the International Space Station (PromISS)," Vrije Universiteit, Brussel, Belgium, URL: [esamultimedia.esa.int/docs/odissea/promiss\\_pr\\_1004.ppt](http://esamultimedia.esa.int/docs/odissea/promiss_pr_1004.ppt)
- <sup>9</sup> Legros, J.C., & Barremaecker L., Heat, Euro Heat Pipes S.A., Nivelles, Belgium, URL: [http://www.esa.int/SPECIALS/Delta\\_Mission/SEME2H0XDYD\\_0.html](http://www.esa.int/SPECIALS/Delta_Mission/SEME2H0XDYD_0.html)
- <sup>10</sup> Kroesen, G.M.W., "ARGES—Energy Efficient Lamps for the Future," Technical University of Eindhoven, Eindhoven, The Netherlands, URL: [http://www.esa.int/SPECIALS/Delta\\_Mission/SEM7RWGHZTD\\_0.html](http://www.esa.int/SPECIALS/Delta_Mission/SEM7RWGHZTD_0.html)
- <sup>11</sup> Kim, J., "Boiling eXperiment Facility," University of Maryland, College Park, MD, URL: <http://exploration.nasa.gov/programs/station/BXF-MABE.html>
- <sup>12</sup> Urban, D., "Smoke and Aerosol Measurement Experiment (SAME)," Glenn Research Center, Cleveland, OH, URL: <http://exploration.nasa.gov/programs/station/SAME.html>
- <sup>13</sup> Cankaya, A., & Arnold W., "Microgravity Science Glovebox CFD Model for the Zero Boil-Off Tank Experiment," AIAA 2006-1336, 44th AIAA Aerospace Sciences Meeting and Exhibit, Reno, Nevada, 9 - 12 January 2006
- <sup>14</sup> Dreyer, M., The University of Bremen, Bremen, Germany, and M. Weislogel, M. , Portland State University, Portland, Oregon, Critical Velocities in Open Capillary Channels (CCF)
- <sup>15</sup> Faeth, G., Smoke Point in Coflow Experiment (SPICE), The University of Michigan, Ann Arbor, Michigan
- <sup>16</sup> Legros, J., "Selectable Optics Diagnostics Instrument (SODI)," Microgravity Research Center Université Libre de Bruxelles, Belgium, URL: <http://www.estec.esa.nl/spaceflight/facilities/diffoil/>
- <sup>17</sup> Odenbach, S., "Magnetic Fluids Experiment Unit (MFEU)," University/ZARM Bremen, Bremen, Germany,
- <sup>18</sup> Lippi, E., "MicroFluidic Light Experiment," European Space Research and Technology Centre (ESTEC), Noordwijk, The Netherlands



National Aeronautics and  
Space Administration  
Marshall Space Flight Center

# 45th AIAA Aerospace Sciences Meeting and Exhibit Reno, Nevada

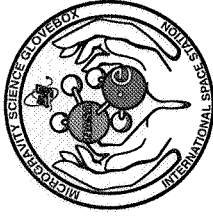

Microgravity Science Glovebox

## The Microgravity Science Glovebox (MSG), a Resource for Gravity-Dependent Phenomena Research on the International Space Station (ISS)

**Reggie Spivey**

Tec-Masters Inc., Huntsville, Alabama

**Linda Jeter**

NASA Marshall Space Flight Center,  
Huntsville, Alabama

**&  
Chris Vonk**

Bradford Engineering, Heerle  
The Netherlands

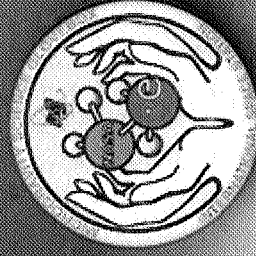

January 09, 2007





National Aeronautics and  
Space Administration  
Marshall Space Flight Center

45th AIAA Aerospace Sciences Meeting and Exhibit

## Microgravity Science Glovebox (MSG)

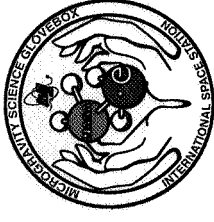

Microgravity Science Glovebox

### AGENDA

- **Introduction**
- **Payload Interfaces and Resources Provided by MSG**
- **Overview of the Research Accomplished in the MSG Facility to Date**
- **Investigations Planned for Near Term Operation in the MSG Facility**
- **Potential Exploration Related Investigations that can be Accommodated by The MSG Facility**
- **Possible enhancements to the current MSG baseline configuration**
- **Conclusion**





National Aeronautics and  
Space Administration  
Marshall Space Flight Center

45th AIAA Aerospace Sciences Meeting and Exhibit

## Microgravity Science Glovebox (MSG)

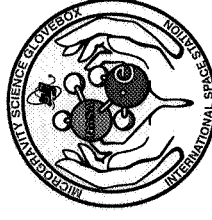

Microgravity Science Glovebox

### Introduction

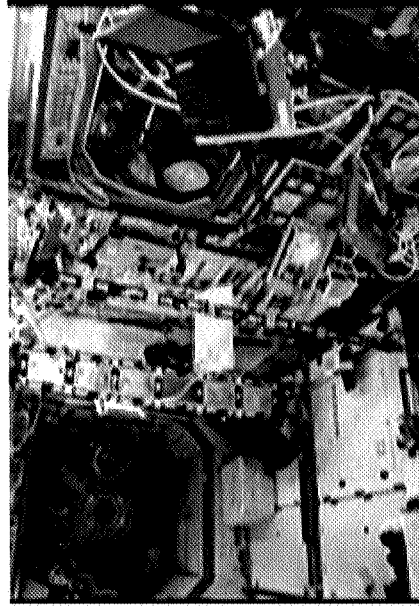

- **The Microgravity Science Glovebox (MSG) is a double rack facility designed for microgravity investigation handling aboard the International Space Station (ISS).**
- **The unique design of the facility allows it accommodate science and technology investigations in a “workbench” type environment**
- **MSG facility provides an enclosed working area for investigation manipulation and observation in the ISS. Provides two levels of containment via physical barrier, negative pressure, and air filtration .**
- **The MSG team and facilities provide quick access to space for exploratory type investigations that are necessary to gain an initial understanding of the role of gravity in the physics associated with new research areas.**



National Aeronautics and  
Space Administration  
Marshall Space Flight Center

45th AIAA Aerospace Sciences Meeting and Exhibit

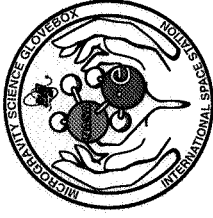

Microgravity Science Glovebox

## Microgravity Science Glovebox (MSG)

### Payload Interfaces and Resources Provided by MSG

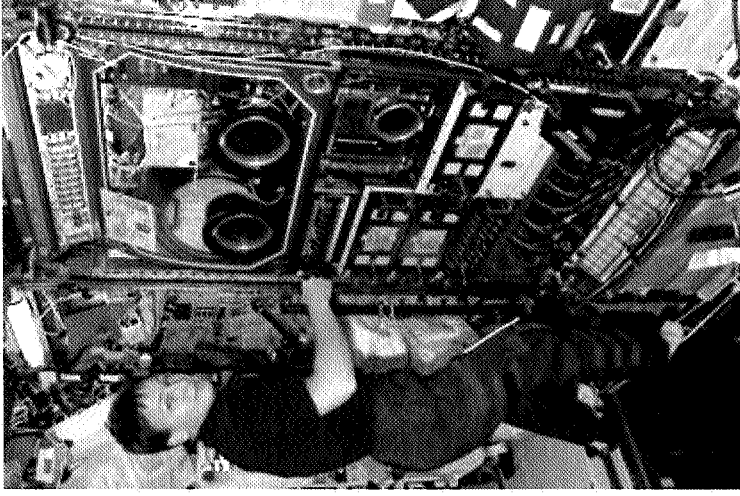
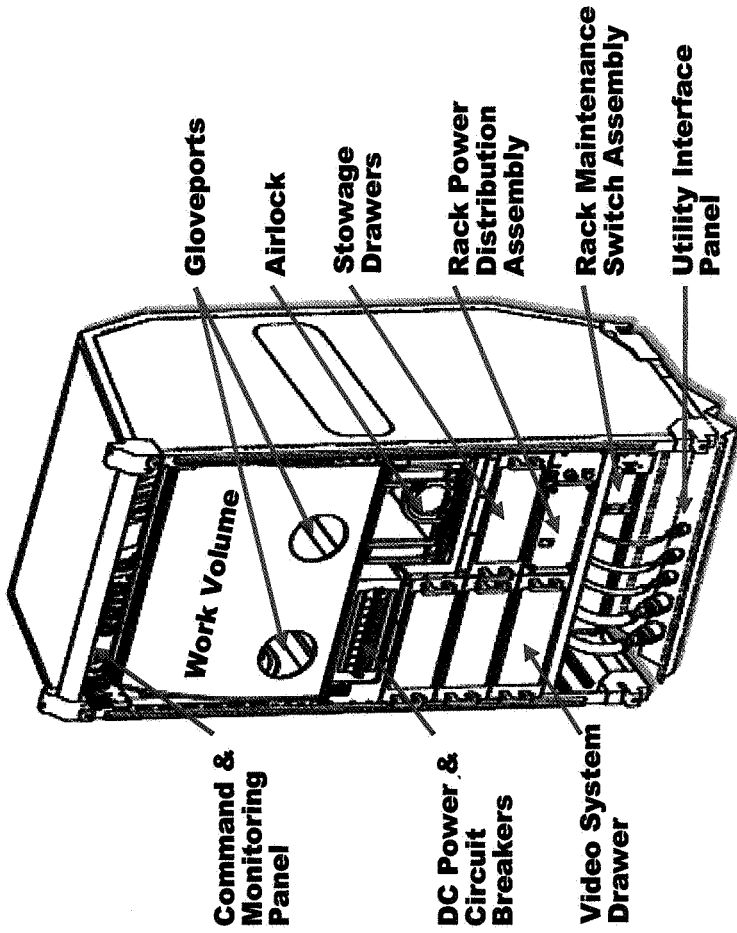

- Developed by the European Space Agency for NASA.
- Delivered to ISS on STS-111 and installed June 2002. Operations started July 02
- Enables crew interaction for setup, sample exchange, and experiment monitoring.
- Provides 2 levels of containment for safety, 1 KW power & cooling, video, and data
- Engineering Unit w/ PRCU used for high-fidelity Verification, Integration, Training and Troubleshooting (Training Unit, Engineering Unit, Ground Unit, & Flight Unit)
- Operational Tele-science Center and local ISS POIC



National Aeronautics and  
Space Administration  
Marshall Space Flight Center

45th AIAA Aerospace Sciences Meeting and Exhibit

## Microgravity Science Glovebox (MSG)

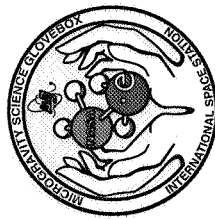

Microgravity Science Glovebox

### Payload Interfaces and Resources Provided by MSG

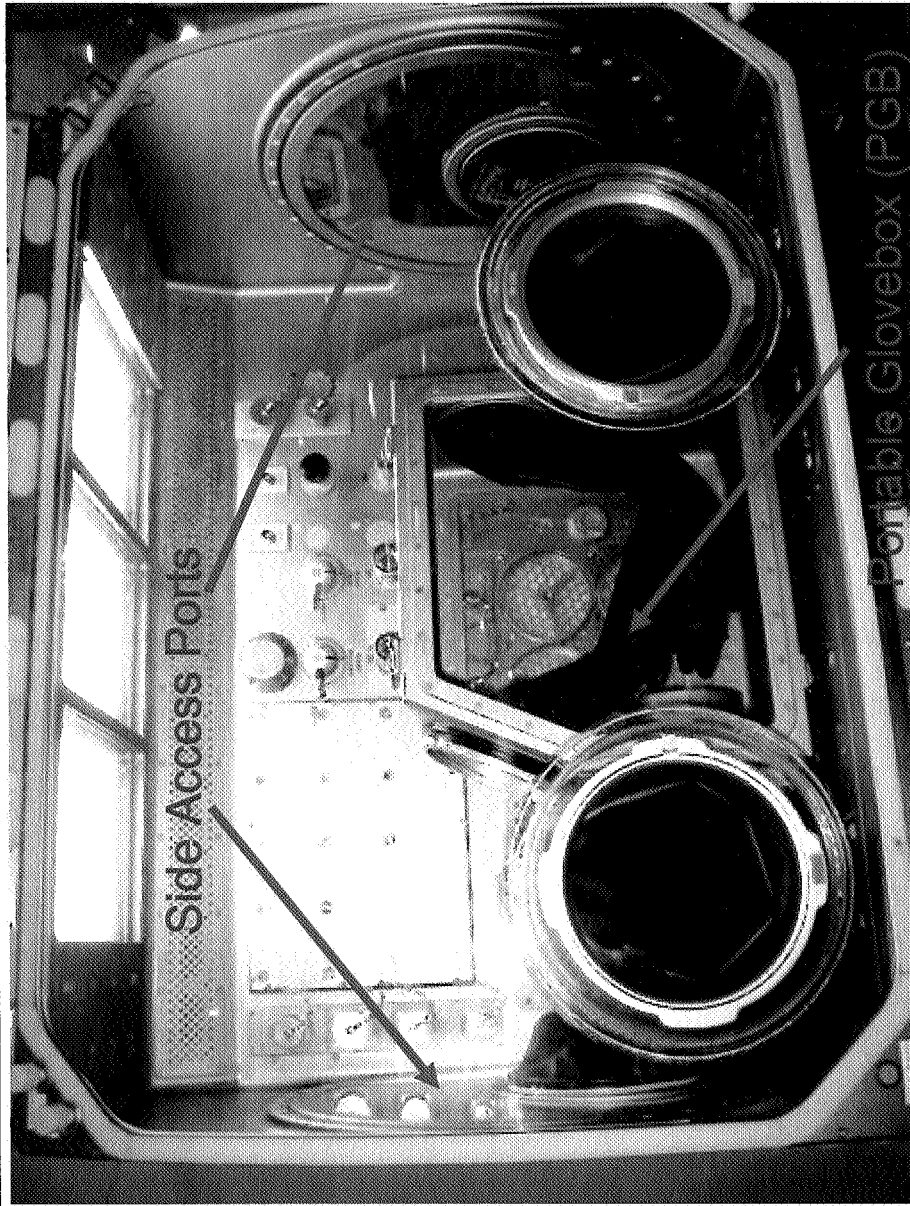

- Additional levels of containment can be achieved by placing the Portable Glovebox (PGB) inside the MSG. With this arrangement, up to 4 levels of containment can be provided.



National Aeronautics and  
Space Administration  
Marshall Space Flight Center

45th AIAA Aerospace Sciences Meeting and Exhibit

## Microgravity Science Glovebox (MSG)

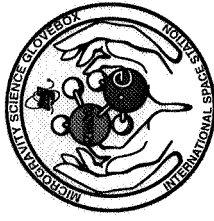

Microgravity Science Glovebox

### Payload Interfaces and Resources Provided by MSG

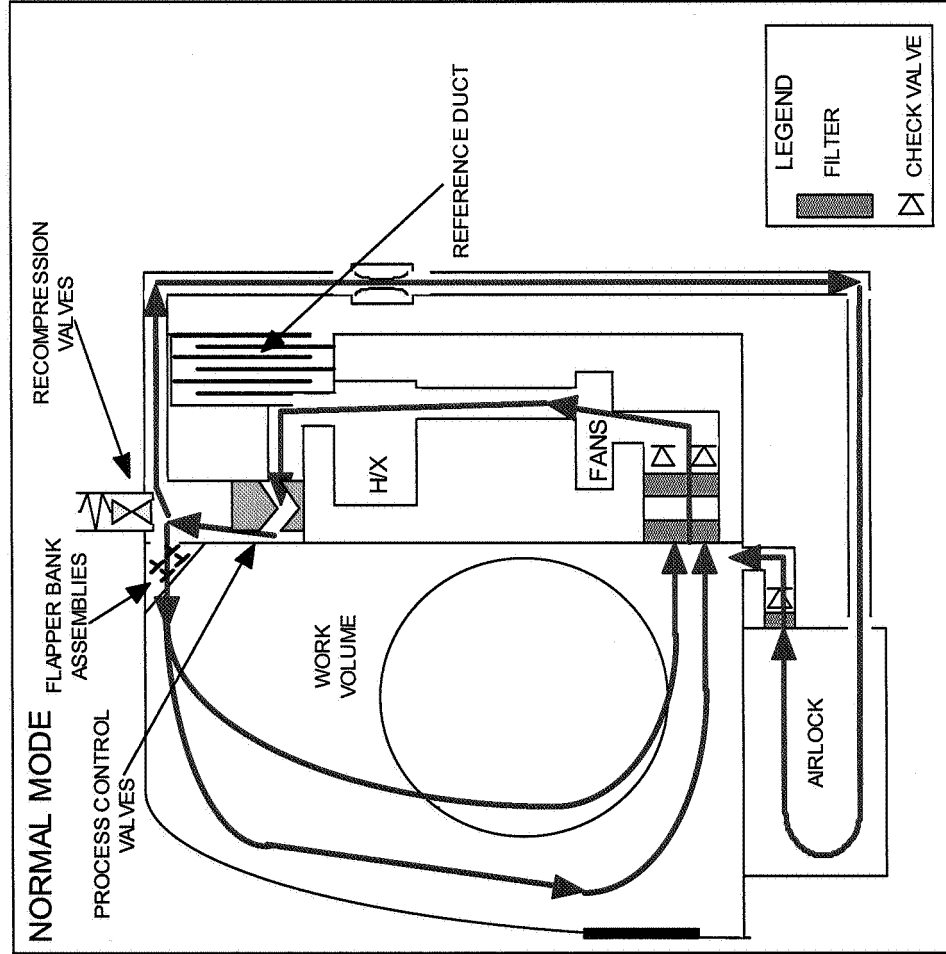

#### Normal Mode of Operation

- One Level of containment provided by air filtration and negative pressure in WV.
- Delta Pressure in WV and across each bank of front and rear filters is continuously monitored by facility.
- Second level of containment provided by physical barrier of MSG WV



National Aeronautics and  
Space Administration  
Marshall Space Flight Center

## 45th AIAA Aerospace Sciences Meeting and Exhibit

# Microgravity Science Glovebox (MSG)

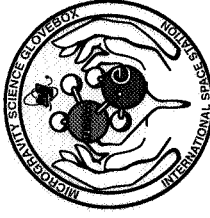

Microgravity Science Glovebox

## Payload Interfaces and Resources Provided by MSG

- **Work Volume(WV) - Volume**
  - 0.255 m<sup>3</sup> = 255 liters
- **Work Volume - Dimensions**
  - 906mm wide x 637mm high
  - 500mm deep (at the floor)
  - 385mm deep (at the top)
- **Maximum size of single piece of equipment in WV (via side access ports)**
  - 406mm diameter
- **Maximum size of single piece of equipment in WV (via the airlock)**
  - 254 x 343 x 299 mm
- **Payload Attachment**
  - M6 threaded fasteners in floor, ceiling, & sides
- **Power available to investigation**
  - +28V DC at useable 7 amps
  - +12V DC at useable 2 amps
  - -12V DC at useable 2 amps
  - +5V DC at useable 8 amps
  - +120V DC at useable 8.3 amps
- **Maximum heat dissipation**
  - 1000W Total
    - 800W from coldplate
    - 200W from air flow
- **General illumination**
  - 1000 lux @ 200mm above WV floor
- **Video**
  - 4 color Hitachi HV-C20 cameras
  - 2 Sony DSRV10 Digital Recorders
  - 2 Sony GV-A500 Analog 8mm Recorders
- **Data handling connections**
  - Two RS422-to-MSG for investigations
  - One MIL-BUS-1553B-to-MSG for communication via MLC
  - Ethernet LAN 1 and LAN 2
- **Filtration**
  - 12 HEPA/charcoal/catalyst WV filters (Replaceable on orbit)
- **1 HEPA/charcoal/catalyst Airlock filter**
  - Replaceable on orbit
- **Up to Two Levels of Containment**
  - Physical barrier of MSG structures, gloves, etc.
  - Negative pressure generated by MSG fans.
- **Other resources available**
  - Gaseous Nitrogen
  - Vacuum (VRS & VES)



National Aeronautics and  
Space Administration  
Marshall Space Flight Center

45th AIAA Aerospace Sciences Meeting and Exhibit

## Microgravity Science Glovebox (MSG)

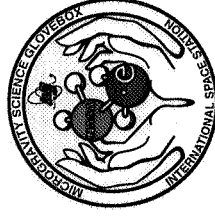

Microgravity Science Glovebox

### Payload Interfaces and Resources Provided by MSG

#### MSG Laptop Computer

- **Purpose**
  - The purpose of the MLCS is to provide an interface to MSG/hosted experiments with minimal experimenter programming required
- **Supported Interfaces**
  - Provides a simple socket based interface to the entire MSG output data stream (including all data from hosted experiments).
  - Provides a simple web based system that allows commands to be issued/measurements to be displayed via HTML.
  - Provides an FTP server that will allow experiments to utilize the laptop hard drive for storage that the MLCS can then downlink via MRDL (Medium Rate Data Link).
  - Provides a socket based interface to the 1553 data stream for experiment data output.



National Aeronautics and  
Space Administration  
Marshall Space Flight Center

45th AIAA Aerospace Sciences Meeting and Exhibit

## Microgravity Science Glovebox (MSG)

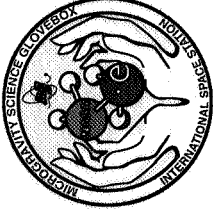

Microgravity Science Glovebox

### Payload Interfaces and Resources Provided by MSG

#### MSG Laptop Computer

- **Payload Uses**
  - An experiment may develop custom software that interfaces to MSG via the socket interface with minimal effort. All existing interfaces have been verified and used in flight.
- **Current Hardware Platform**
  - IBM 760XD laptop, 5 gb hard drive, 104 mb ram running Windows NT 4.0 SP 5. Supports Ethernet, 1 RS232/422 (via converter).
- **Next Platform**
  - IBM A31p laptop, 60 gb hard drive, 1 gb ram running Windows 2000 (service pack 4). Supports dual Ethernet, 1 RS232/422 (via converter). USB via operating system.



National Aeronautics and  
Space Administration  
Marshall Space Flight Center

45th AIAA Aerospace Sciences Meeting and Exhibit



Microgravity Science Glovebox

## Microgravity Science Glovebox (MSG)

### Payload Interfaces and Resources Provided by MSG

#### MSG Video Drawer

- The video drawer includes 4 color cameras, 2 monitors, 2 analogue and 2 digital recorders, a touchpad, a power distribution unit, a power and data line and a controller board.
- The video drawer has a dedicated controller that allows the user to command the video system from the ground via an input device that is connected to the RS-422 serial interface or via the touchpad.



Hitachi HV-C20

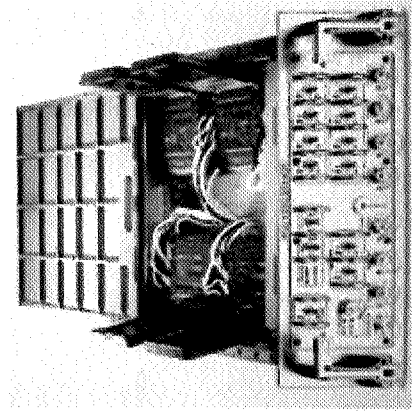

MSG Video Drawer

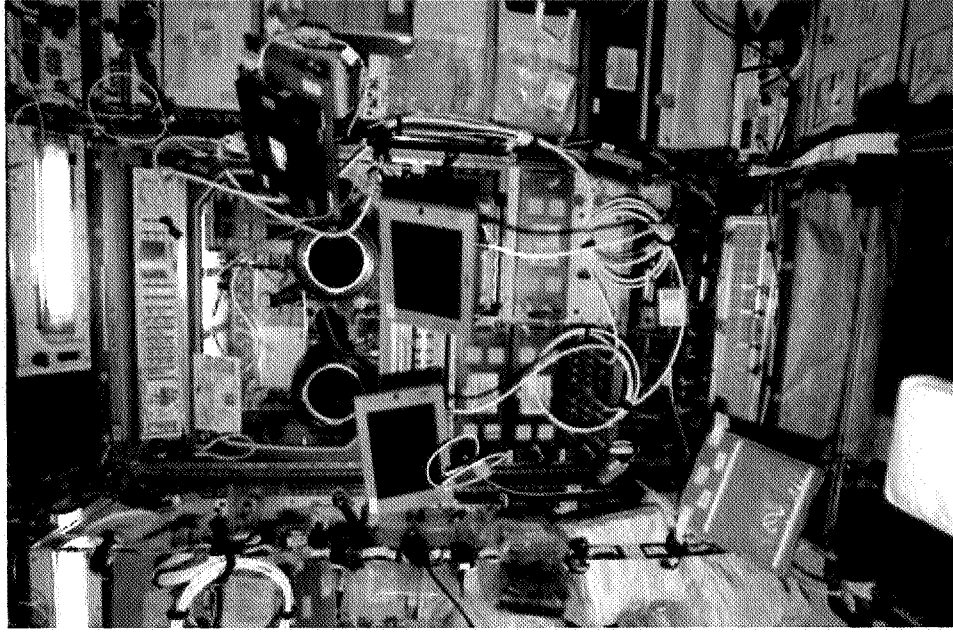

MSG On-Orbit





National Aeronautics and  
Space Administration  
Marshall Space Flight Center

45th AIAA Aerospace Sciences Meeting and Exhibit

## Microgravity Science Glovebox (MSG)

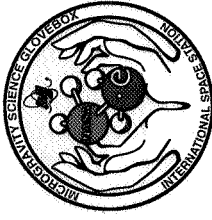

Microgravity Science Glovebox

### Payload Interfaces and Resources Provided by MSG

#### MSG Cleanup Equipment

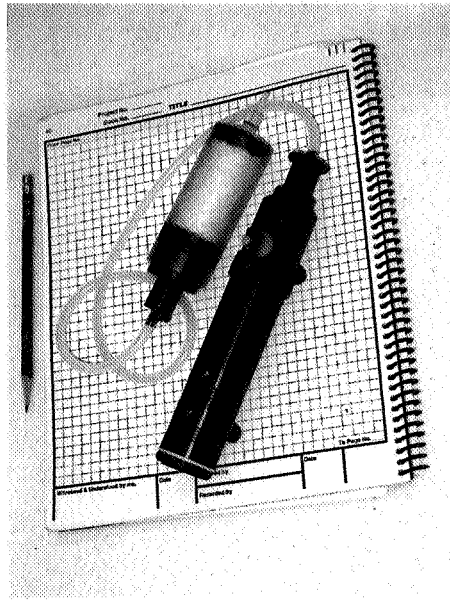

**MSG Scavenge Pump**



**MSG Particle Catchers**

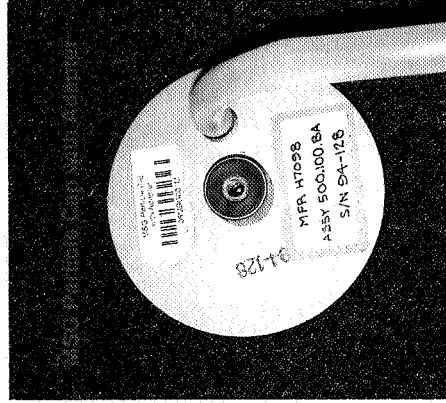

**MSG Particle Cap & Adapter**



National Aeronautics and  
Space Administration  
Marshall Space Flight Center

45th AIAA Aerospace Sciences Meeting and Exhibit

## Microgravity Science Glovebox (MSG)

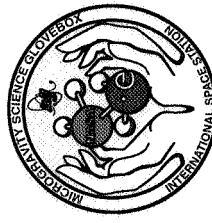

Microgravity Science Glovebox

### Payload Interfaces and Resources Provided by MSG

#### Available Facilities

- **Flight Unit**
- **Engineering Unit**
  - Flight equivalent unit to be used as verification tool for Investigation hardware
- **Ground Unit**
  - Flight like unit to be used for development and limited verifications
- **Training Unit**
- **Ancillary Hardware**
  - MSG Laptop Computer
  - Video equipment, Cables, Mechanisms, etc.
  - Cleanup Equipment

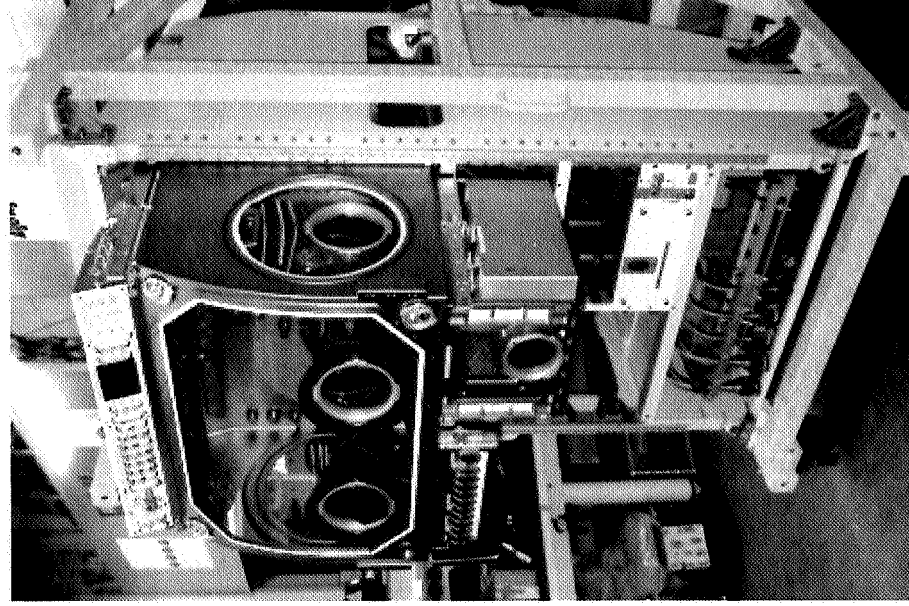



National Aeronautics and  
Space Administration  
Marshall Space Flight Center

# 45th AIAA Aerospace Sciences Meeting and Exhibit

## Microgravity Science Glovebox (MSG)

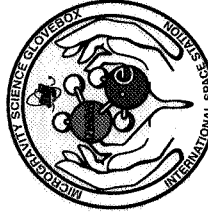

Microgravity Science Glovebox

### Payload Interfaces and Resources Provided by MSG

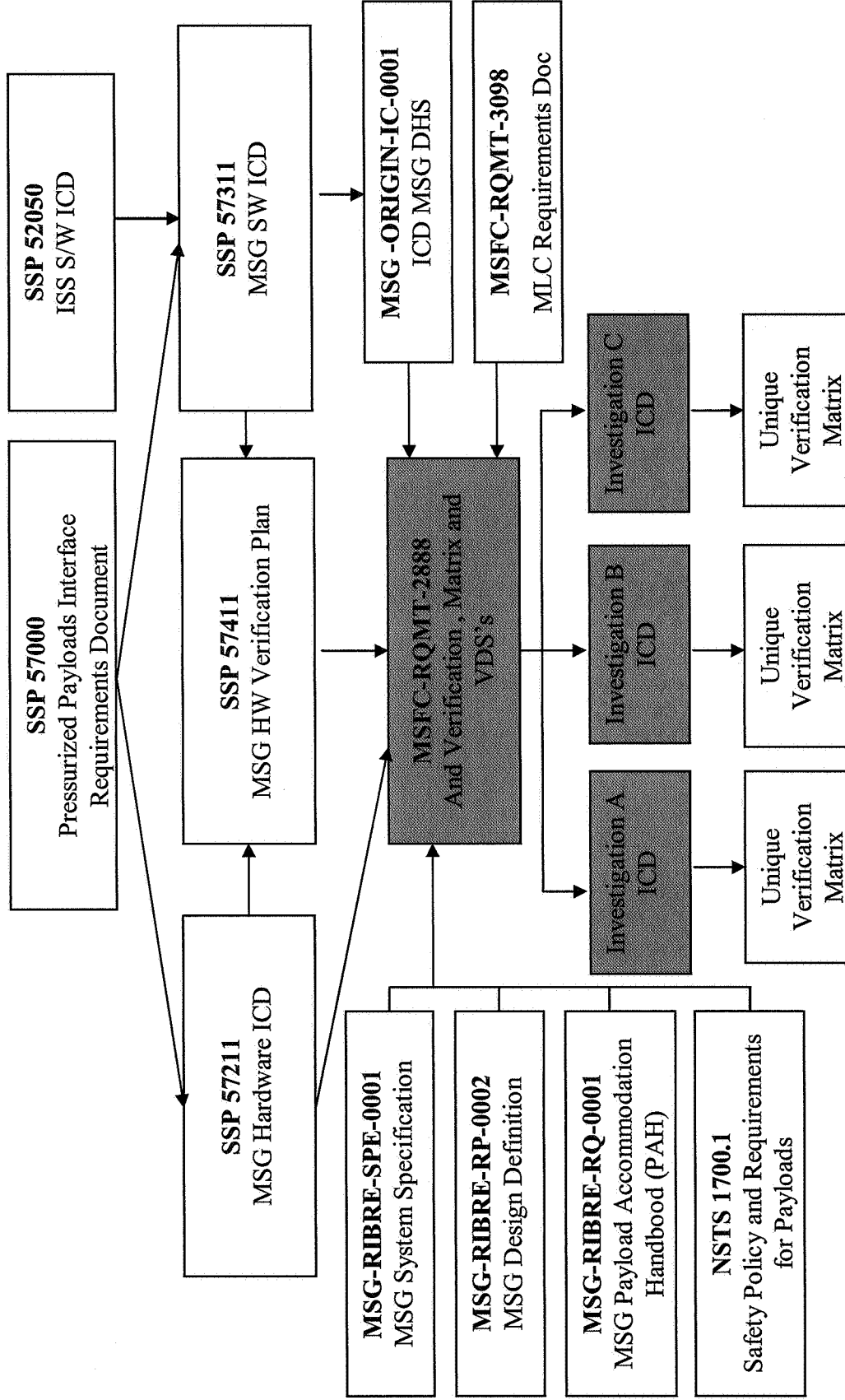



National Aeronautics and  
Space Administration  
Marshall Space Flight Center

45th AIAA Aerospace Sciences Meeting and Exhibit

## Microgravity Science Glovebox (MSG)



Microgravity Science Glovebox

### **Integration and Test Services Available to Investigations**

- **Dedicated Investigation Payload Integration Manager (IPIM)**
  - **Liaison for All Payload Activates at MSFC**
  - **Interface Control Document (ICD) Development and Maintenance**
  - **Closeout of all MSG Related Verification with JSC PE&I**
- **C&DH Support (Including Ground and Flight Displays)**
- **MSG Laptop Computer & Server Software**
- **Development testing in the MSG Ground Unit**
- **End-to-End Verification Testing in the MSG Engineering Unit**
- **Development of Integrated Phase III Safety Data Package and Presentation to PSRP**
- **Labeling of Flight Hardware**
- **Acoustic Testing**
- **Crew Training for Operations Performed in the MSG**
- **Development of MSG Crew Procedures and Operations Products**
- **Real Time Operations Support in the MSG Telescience Support Center (TSC)**



National Aeronautics and  
Space Administration  
Marshall Space Flight Center

45th AIAA Aerospace Sciences Meeting and Exhibit

## Microgravity Science Glovebox (MSG)

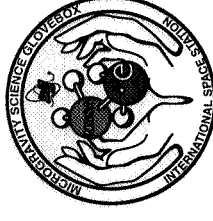

Microgravity Science Glovebox

### Integration and Test Services Available to Investigations

- **EMI/EMC Testing**
- **Vibration Testing**
- **Offgas Testing**
- **Environmental Testing**
- **Leak Testing**
- **Fabrication Services**



National Aeronautics and  
Space Administration  
Marshall Space Flight Center

## 45th AIAA Aerospace Sciences Meeting and Exhibit

# Microgravity Science Glovebox (MSG)



Microgravity Science Glovebox

### Overview of the Research Accomplished in the MSG Facility to Date

Investigation Name	Main Objective
Solidification Using A Baffle in Sealed Ampoules <b>(SUBSA) -- MSFC</b>	To improve science's understanding of the formation of semiconductor crystals. Directionally solidified indium antimonide samples.
Towards Understanding Pore Formation and Mobility during Directional Solidification in a Microgravity Environment <b>(PFMI) -- MSFC</b>	To improve science's understanding of solidification processes and the effects of imperfections in the molten material. Directionally solidified transparent modeling material, succinonitrile (SCN) and succinonitrile water mixtures.
Investigating the Structure of Paramagnetic Aggregates from Colloidal Emulsions <b>(InSPACE)</b> -- GRC	To determine the true three-dimensional low-energy structure of a magnetorheological (MR) emulsion in a pulsed magnetic field. Examined the way small magnetic particles interacted with the complex properties found in MR fluids.
Coarsening in Solid Liquid Mixtures-2 <b>(CSLM-2)</b> - - GRC	To improve the quality of metals by studying coarsening. The investigation analyzed the rate at which particles of tin suspended in a liquid comprised of molten tin/lead alloy, increase in size. A phenomenon known as coarsening.



National Aeronautics and  
Space Administration  
Marshall Space Flight Center

45th AIAA Aerospace Sciences Meeting and Exhibit

## Microgravity Science Glovebox (MSG)



Microgravity Science Glovebox

### Overview of the Research Accomplished in the MSG Facility to Date

Investigation Name	Main Objective
Combustion Synthesis under Microgravity Conditions ( <b>COSMIC</b> ) -- ESA	To investigate the relationship between general physico-chemical mechanisms of combustion and formation of the microstructure and composition of fields. Studied the microstructure formation of compressed powder samples (in casu Ti-Al-B) during self-propagating high-temperature combustion processes (SHS).
Microgravity Experiment For the Measurement of Diffusion Coefficients in Crude Oil ( <b>DCCO</b> ) -- ESA	To investigate isothermal diffusion and the Soret effect (thermodiffusion). Measured diffusion coefficients of ternary mixtures of organic compounds.
<b>Nanoslab</b> -- ESA	To create more effective zeolite crystal structures by mixing different zeolite solutions with a range of crystal-forming catalysts.
Protein Microscope for the International Space Station ( <b>PromISS-1, 2, 3 ..</b> ) -- ESA	To improve science's understanding of the fundamental processes underlying the protein crystallization process



National Aeronautics and  
Space Administration  
Marshall Space Flight Center

## 45th AIAA Aerospace Sciences Meeting and Exhibit

# Microgravity Science Glovebox (MSG)



Microgravity Science Glovebox

### Overview of the Research Accomplished in the MSG Facility to Date

Investigation Name	Main Objective
Heat transfer performance of a grooved heat pipe (HEAT) -- ESA	Investigation of the effectiveness of grooved heat pipes in the weightlessness of space.
<b>ARGES</b> Investigation -- Energy efficient lamps for the future. -- <b>ESA</b>	To improve the understanding of High-Intensity Discharge (HID) lamps and how they are affected by imperfections. Ultimate objective was to improve the efficiency and life expectancy of HID lamps.





National Aeronautics and Space Administration  
Marshall Space Flight Center

# 45th AIAA Aerospace Sciences Meeting and Exhibit

## Microgravity Science Glovebox (MSG)

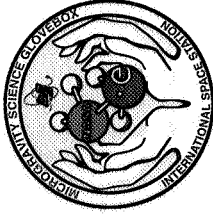

Microgravity Science Glovebox

### Typical ISS Flight Program

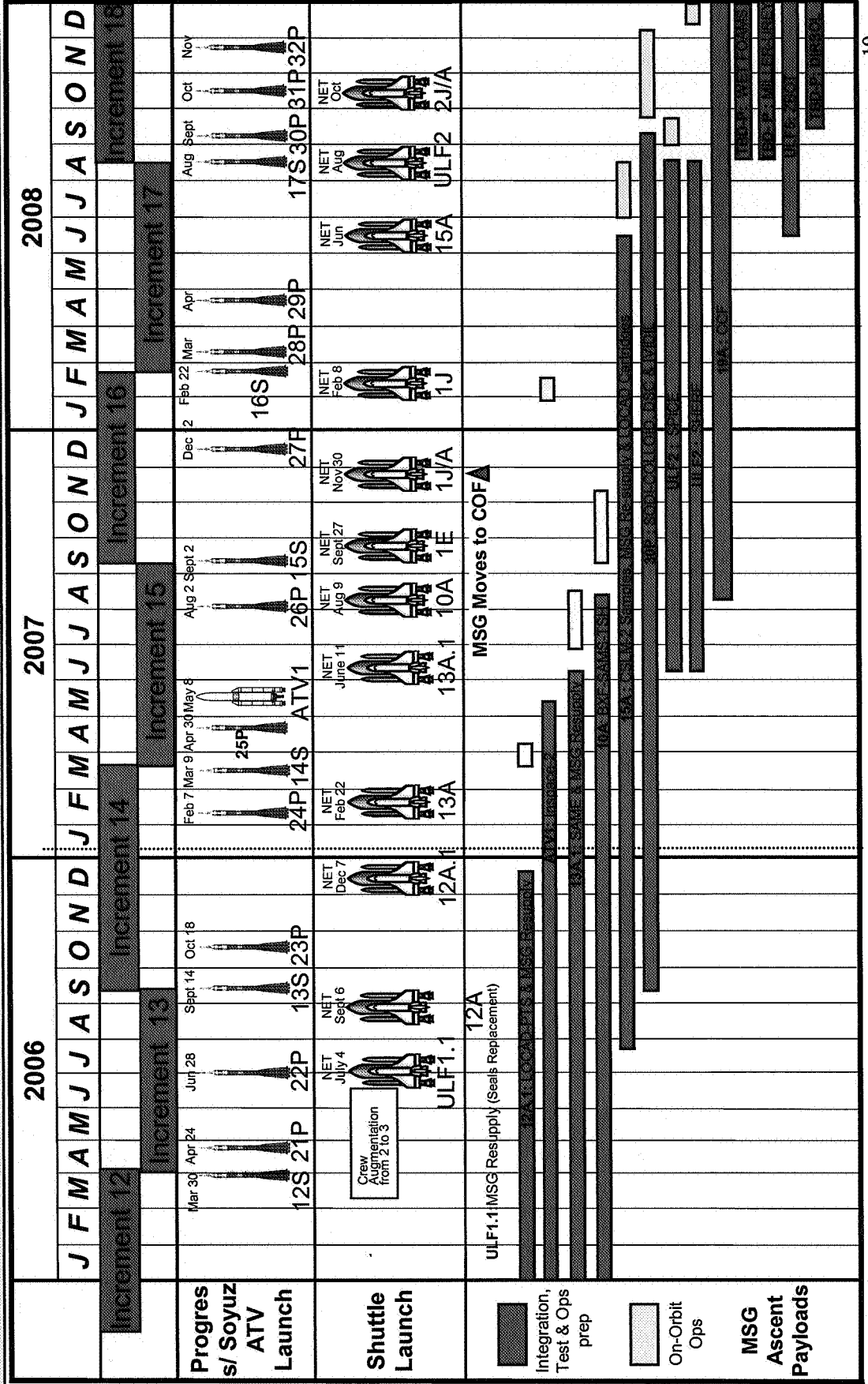



National Aeronautics and  
Space Administration  
Marshall Space Flight Center

45th AIAA Aerospace Sciences Meeting and Exhibit

## Microgravity Science Glovebox (MSG)

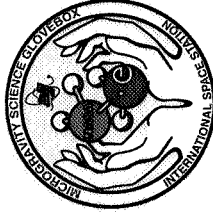

Microgravity Science Glovebox

### Investigations Planned for Near Term Operation in the MSG Facility

Investigation Name	Main Objective
Boiling eXperiment Facility (BXF)– NASA GRC	To improve our understanding of the process involved with boiling in gravity and microgravity. The research will enable the development of more efficient cooling systems on future spacecraft and on Earth.
Smoke Aerosol Measurement Experiment (SAME )– NASA GRC	To determine the particle size distributions of the smokes generated from a variety of overheated spacecraft materials and from microgravity fires. The objective is to provide the data that spacecraft designers need to properly design and implement fire detection in spacecraft.
Zero Boil- Off Tank Experiment (ZBOT) – NASA GRC (Not currently manifested)	To improve the scientific understanding of the storage of cryogenic fluids in low gravity conditions. Effective, affordable, and reliable cryogenic fluid storage is essential for propellant and life support systems on interplanetary spacecraft



National Aeronautics and  
Space Administration  
Marshall Space Flight Center

45th AIAA Aerospace Sciences Meeting and Exhibit

## Microgravity Science Glovebox (MSG)

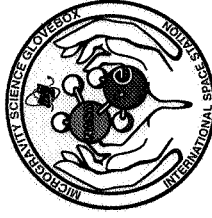

Microgravity Science Glovebox

### Investigations Planned for Near Term Operation in the MSG Facility

Investigation Name	Main Objective
Shear History Extensional Rheology Experiment (SHERE) -- GRC	To study the effect of preshear on the transient evolution of the microstructure and viscoelastic tensile stresses for monodisperse dilute polymer solutions.
Investigating the Structure of Paramagnetic Aggregates from Colloidal Emulsions (InSPACE-2) -- GRC	Continuation of InSPACE-1 to determine the true three-dimensional low-energy structure of a magnetorheological (MR) emulsion in a pulsed magnetic field. Examines the way small magnetic particles interacted with the complex properties found in MR fluids.
Smoke Point in Coflow Experiment (SPICE) -- GRC	Combustion investigation to observe non-buoyant round laminar jet diffusion flames in air coflow at standard temperature and pressure (STP) in a reduced gravity environment.



National Aeronautics and  
Space Administration  
Marshall Space Flight Center

## 45th AIAA Aerospace Sciences Meeting and Exhibit

# Microgravity Science Glovebox (MSG)



Microgravity Science Glovebox

### Investigations Planned for Near Term Operation in the MSG Facility

Investigation Name	Main Objective
Selectable Optics Diagnostics Instrument (SODI) (ESA)	<ul style="list-style-type: none"> <li>• To Study diffusion and Soret phenomena and measurement of these coefficients in multi-component mixtures (liquids). (DSC)</li> <li>• To Study the influence of controlled vibration stimuli on these diffusion processes. (IVILID)</li> <li>• To Study the aggregation (clustering) of colloidal solutions. (COLLOID)</li> </ul>
Critical Velocities in Open Capillary Channels (CCF)	<ul style="list-style-type: none"> <li>• To investigate liquid flow through an open capillary channel in a reduced gravity environment.</li> <li>• The goal is the determination of the critical flow rate up to which a steady flow is achieved in the channel. The results are important for fluid management in space and the fundamental fluid mechanics problem of flow rate limitation.</li> </ul>
Magnetic Fluids Experiment Unit (MFEU)– (ESA)	<p>To study heat and mass transfer phenomena in suspensions of magnetic nanoparticles under the influence of variable temperature gradients and magnetic fields on different geometries. The experiments will involve liquid ferrofluids in a cylindrical gap.</p>



National Aeronautics and  
Space Administration  
Marshall Space Flight Center

45th AIAA Aerospace Sciences Meeting and Exhibit

## Microgravity Science Glovebox (MSG)

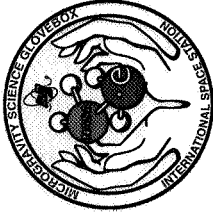

Microgravity Science Glovebox

### Potential Future Exploration Related MSG Investigations

- The MSG is an ideal platform for research required to advance the technology readiness levels (TRL) needed for the Crew Exploration Vehicle and the Exploration Initiative.
- Areas of Needed Research include:
  - Thermal Management in Aerospace Systems
  - Microgravity Fluid Physics Research and Technology
  - Spacecraft Fire Safety and Microgravity Combustion
  - Microgravity Materials Science and Technology
  - Combustion and Reacting Systems
  - Advanced Life Support Technologies for Exploration
  - In situ Fabrication and Repair



National Aeronautics and  
Space Administration  
Marshall Space Flight Center

45th AIAA Aerospace Sciences Meeting and Exhibit

## Microgravity Science Glovebox (MSG)

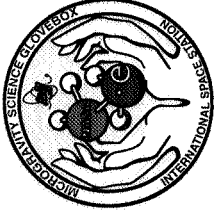

Microgravity Science Glovebox

### Potential Enhancements to Improve the Usability of the MSG

Some Potential Enhancements to the Current MSG Facility include;

- Additional cooling capacity for experiments that require a low temperature heat sink
- Life Science Glovebox filter technology
- Sterilization capability based on ozone technology



National Aeronautics and Space Administration  
Marshall Space Flight Center

45th AIAA Aerospace Sciences Meeting and Exhibit

# Microgravity Science Glovebox (MSG)



Microgravity Science Glovebox

## Potential Enhancements to Improve the Usability of the MSG

Additional cooling capacity for experiments that require a low temperature heat sink

- The current MSG Water Cold Plate (WCP) Provides a minimum temperature of 26-28 °C.

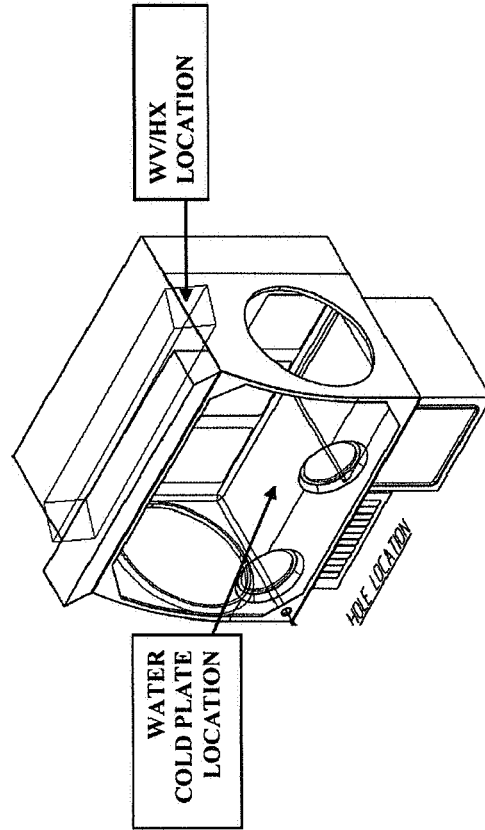
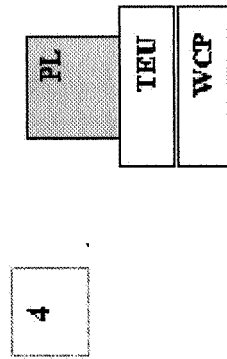

- The addition of a Thermal Electric Unit (TEU) could reduce the minimum cold plate temperature to 15-25 °C .



National Aeronautics and  
Space Administration  
Marshall Space Flight Center

45th AIAA Aerospace Sciences Meeting and Exhibit

## Microgravity Science Glovebox (MSG)



Microgravity Science Glovebox

### Potential Enhancements to Improve the Usability of the MSG

Life Science Glovebox (LSG) filter technology

- MSG uses a front and rear filter system and has no fresh air supply.
- The MSG front filter contains (in the direction of flow) a HEPA, Charcoal and catalyst.
- The MSG rear filter duplicates this capability except for the HEPA.
- The LSG filters also have the HEPA but then use a maximized active charcoal bed (impregnated charcoal) dedicated to absorb/contain typical life sciences fluids/gases.
- The MSG filters can be modified to use the same active charcoal as used for the LSG filters
- This approach keeps the same interfaces and only yields a minor protrusion into the WV.



View of proposed MSG-L filter





National Aeronautics and  
Space Administration  
Marshall Space Flight Center

45th AIAA Aerospace Sciences Meeting and Exhibit

## Microgravity Science Glovebox (MSG)



Microgravity Science Glovebox

### Potential Enhancements to Improve the Usability of the MSG

Sterilization capability based on ozone technology

- In order to accommodate many biological investigations, a sterilization method must be developed for the MSG.
- One of the features of Biological Glovebox (BGB) used in the Columbus Lab, is sterilization by means of ozone.
- A similar approach could be developed for the MSG using a ozone sterilization unit and the portable glovebox (PGB) placed inside the MSG.

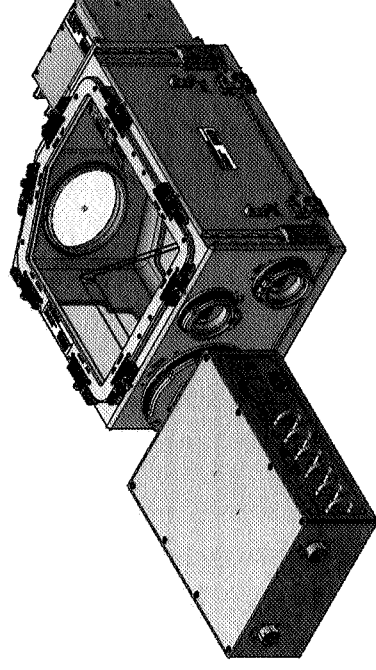

View of proposed PGB-Sterilization Unit



National Aeronautics and  
Space Administration  
Marshall Space Flight Center

45th AIAA Aerospace Sciences Meeting and Exhibit

## Microgravity Science Glovebox (MSG)

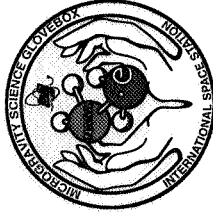

Microgravity Science Glovebox

### Conclusion

- The MSG is a very versatile and capable research facility on the ISS.
- The Microgravity Science Glovebox (MSG) on the International Space Station (ISS) has been used for a large body of research in material science, thermal management, protein crystal growth, life sciences, and technology demonstration.
- MSG is an ideal platform for gravity-dependent phenomena related research. Moreover, the MSG provides engineers and scientists a platform for research in an environment similar to the one that spacecraft and crew members will actually experience during space travel and exploration.
- The MSG is ideally suited to provide quick, inexpensive access to space for exploratory type investigations that are necessary to gain an initial understanding of the role of gravity in the physics associated with new research areas.
- The MSG facility is a vital component of NASA's vision for space exploration.



National Aeronautics and  
Space Administration  
Marshall Space Flight Center

45th AIAA Aerospace Sciences Meeting and Exhibit

## Microgravity Science Glovebox (MSG)

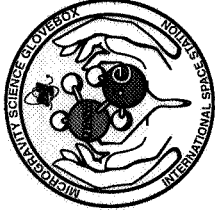

Microgravity Science Glovebox

### Acknowledgements

The authors would like to thank the members of the MSG Integration Team for their assistance, and review of this paper. Specifically, Andrew Tygielski, Phillip Bryant, Chris Butler, Jeff Smith, and Frankie Jernigan provided invaluable information and assistance.