

Rendezvous and Proximity Operations of the Space Shuttle

John L. Goodman*

United Space Alliance, LLC, Houston, Texas, 77058

Source of Acquisition
NASA Johnson Space Center

Space Shuttle rendezvous missions presented unique challenges that were not fully recognized when the Shuttle was designed. Rendezvous targets could be passive (i.e., no lights or transponders), and not designed to facilitate Shuttle rendezvous, proximity operations and retrieval. Shuttle reaction control system jet plume impingement on target spacecraft presented induced dynamics, structural loading and contamination concerns. These issues, along with limited forward reaction control system propellant, drove a change from the Gemini/Apollo coullptic profile heritage to a stable orbit profile, and the development of new proximity operations techniques. Multiple scientific and on-orbit servicing missions; and crew exchange, assembly and replenishment flights to Mir and to the International Space Station drove further profile and piloting technique changes, including new relative navigation sensors and new computer generated piloting cues.

Nomenclature

- H Bar = unit vector along the target orbital angular momentum vector
- i_x = LVLH +X axis vector
- i_y = LVLH +Y axis vector
- i_z = LVLH +Z axis vector
- kft. = kilo-feet
- MC = Mid-course Correction maneuver
- MCC = Mid-Course Correction maneuver
- min. = minutes
- n. m. = nautical miles
- NC = phasing maneuver
- NCC = Corrective Combination maneuver
- NH = Height maneuver
- NPC = Plane Change maneuver
- NSR = Slow Rate (co-elliptic) maneuver
- r_T = target position vector
- R Bar = unit vector pointed from target to the center of the Earth
- Ti = Transition initiation maneuver
- TPI = Terminal Phase Initiation maneuver
- TPM = Terminal Phase Mid-course maneuver
- v_T = target velocity vector
- V Bar = unit vector of cross product of target orbital angular momentum and target position vectors
- ΔH = height differential between chaser and target spacecraft
- ΔV = delta velocity

I. Introduction

At the end of the Apollo era, rendezvous principles were well understood, but extensive adaptation of proven rendezvous principles and new technique development was required to meet new Shuttle rendezvous/proximity operations requirements, overcome emerging Shuttle design limitations and surmount programmatic challenges. Shuttle development was subjected to close scrutiny for budget and schedule compliance. Vehicle design was baselined before many of

the issues with Shuttle rendezvous and proximity operations had been fully identified and resolved, which in turn resulted in complex operational work-arounds. Proposals for vehicle capabilities competed for funding based on available budget, available schedule, and criticality to safety and mission success. Technical challenges in building a reusable orbital spacecraft, such as propulsion, thermal protection, structures and weight control, took priority over the development of other systems and flight techniques that presented (or were assumed to present) less technical risk, such as rendezvous, due in part to the success of Gemini and Apollo.

Many papers have been published on theoretical aspects of rendezvous, with little mention of real-world constraints and challenges other than trajectory optimization. While some papers have focused on certain technical aspects of Shuttle rendezvous, the programmatic constraints and technical challenges encountered during early Shuttle mission analysis in the 1970s have not been adequately detailed in the literature. An understanding of how programmatic and technical challenges shaped vehicle operation and mission design is essential for flying safe and successful missions, and for mitigating cost, schedule and technical risk in future programs.¹

II. Historical Background - Mercury, Gemini, Apollo

In the late 1950s research into spacecraft rendezvous became a popular topic in academic, industry, and government circles.^{2,3} Studies of manual and automatic rendezvous conducted by the NASA Langley Research Center was a key factor behind development and acceptance of the Lunar Orbit Rendezvous mission profile for Apollo.^{4,6}

On-orbit viewing of deployed objects and strobes was evaluated during several Mercury flights to determine the ability of the human eye to support manual piloting.⁷

In 1962 some Langley rendezvous specialists moved with the Space Task Group to the newly formed Manned Spacecraft Center (MSC) in Houston. NASA and contractor personnel from various disciplines at MSC, and the MSC Mission Planning and Analysis Division in particular, turned rendezvous theory into reality during the Gemini Program.⁸ The Gemini flights established an experience base of rendezvous mission planning and execution in preparation for safety-critical Apollo rendezvous (Table 1).^{9,15} The aviator perspective of astronaut Edwin E. Aldrin was particularly instrumental in the development of manual piloting and contingency rendezvous techniques.¹⁶

Rendezvous became a well-practiced art during the Apollo missions.¹⁷ Apollos 7, 9, and 10 successfully exercised rendezvous systems and piloting techniques in preparation for the first lunar

Copyright © 2005 by United Space Alliance, LLC. Published by the American Institute of Aeronautics and Astronautics with permission. These materials are sponsored by the National Aeronautics and Space Administration under Contract NAS9-20000. The U.S. Government retains a paid-up, nonexclusive, irrevocable worldwide license in such materials to reproduce, prepare derivative works, distribute copies to the public, and perform publicly and display publicly, by or on behalf of the U.S. Government. All other rights are reserved by the copyright owner.

* Technical Staff, Flight Design and Dynamics, 600 Gemini Ave., Member AIAA.

Should like this across both columns + more visible
U.S.A. Copyright
1 of 17

Table 1 Gemini Rendezvous Accomplishments

- Coelliptic rendezvous from above and below
- Stable orbit, direct ascent and equal period (football) rendezvous
- Rendezvous during both orbital night and day
- Use of only optical measurements (no radar)
- Station-keeping and docking
- Simultaneous countdown of chaser and target launch vehicles
- Launch during a narrow launch window
- Real time maneuver targeting using data from ground based or onboard navigation sensors
- Conducting multiple rendezvous operations in a single mission within a propellant budget

landing. These missions, coupled with the success of Apollos 11 and 12, led to the development of a shorter rendezvous profile that was flown on Apollos 14 through 17 to increase lunar surface stay time.¹⁷ Complex contingency rendezvous procedures to be flown by either the Command/Service Module or Lunar Module were developed and continuously refined during the Apollo Program, but were never flown due to nominal spacecraft performance. Apollo hardware, software and rendezvous trajectory techniques were later adapted to support rendezvous and docking with Skylab and Soyuz.^{18,20}

III. A New Direction In Mission Activities

Space Shuttle rendezvous and proximity operations represented a significant departure from Gemini and Apollo.²¹ Most rendezvous targets would not possess active navigation aids (transponders or lights), nor were many of them originally designed to support rendezvous, retrieval and on-orbit servicing. Shuttle rendezvous missions also involved deploy and retrieval of the same or different spacecraft on the same mission, and on some missions more than one rendezvous.

Relative chaser and target spacecraft size were significantly different. Previous chaser vehicles (Gemini, Apollo Command/Service Module (CSM) and Lunar Module (LM)) were about the same size as the target spacecraft (Gemini 7, Agena, Augmented Target Docking Adapter, LM, Soyuz) or smaller (Saturn S-IVB, Skylab). Until the Mir and International Space Station (ISS) missions, the orbiter was much larger than its rendezvous targets.

Rather than docking at -1 foot/second, as was done in Gemini and Apollo, satellite retrievals involved capture and berthing with a robotic arm (the Remote Manipulator System, or RMS), with nearly zero relative velocities between the two spacecraft. Robotic arm operations, capture and berthing had not been performed on previous programs. RMS design requirements were a function of orbiter stopping distance, arm joint loads and the ability of the crew to detect and control relative rates.

Shuttle docking with Mir and ISS required a contact velocity an order of magnitude lower than Gemini and Apollo, with tighter piloting tolerances on time of docking and contact velocity. Gemini and Apollo docking were axial, along the crew line-of-sight and in direct view of the crew. Shuttle grappling and docking required the use of cameras to provide adequate crew visibility and cues for final control. Since target spacecraft could possibly already be in orbit during mission planning, some grapple equipment used by the Shuttle Program was designed from documentation of target spacecraft hardware, and was not mated on the ground for preflight checks as was done for Gemini and Apollo docking hardware.

IV. Early Rendezvous Study

In 1969, a study of on-orbit ΔV budgeting was conducted for the Advanced Logistics System (ALS), an early name for the Space Shuttle. A five-maneuver coelliptic profile was proposed for a resupply mission to a space station in 200 or 270 n.m. circular orbits, with an inclination of 55 degrees. The study assumed a launch directly into the orbital plane of the station, a daily launch window, a minimum phasing perigee of 100 n.m., rendezvous within 24 hours of launch, and deorbit within 24 hours of departure from the station. Apollo and Gemini flight techniques, sensor characteristics, and flight experience was factored into the propellant budgeting estimate. The ALS terminal phase was the same as that used on most Gemini and Apollo missions (Fig. 1).^{9,20} The study showed that propellant required could be significantly reduced if the requirements for every day launch, rendezvous duration and minimum perigee were relaxed.

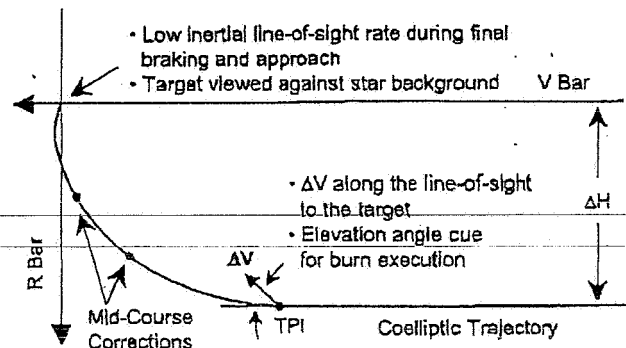

Fig. 1 Terminal Phase for coelliptic rendezvous. See Appendix for coordinate frame description.

V. Shuttle Design Reference Missions

During the Shuttle Phase B studies (1970-1971), the following assumptions were made: 1) rendezvous techniques and principles were well understood, and the flight regime should not contain technical challenges; 2) the coelliptic terminal phase from Gemini and Apollo will be used; 3) a target mounted navigation transponder will allow tracking out to the maximum range achieved during the Apollo Program (~ 300 n.m.); 4) radar skin tracking of a passive target out to 10 n.m. was a contingency mode of operation; 5) the Shuttle will be capable of autonomous rendezvous; and 6) on-board computer capacity will be significantly greater than Apollo.

By 1973, four Shuttle reference missions were in use for mission planning, vehicle sizing and subsystem requirements definition, and three of them involved rendezvous.²² There was also a requirement (later waved) for a Shuttle to rescue the crew of another Shuttle stranded in orbit. Rescue was to occur no later than 96 hours after launch of the rescue vehicle. The rescue Shuttle was to be able to phase from either above or below the other Shuttle's orbit, depending on the initial phasing at launch.

Rendezvous For Reference Missions 1 and 2

The Mission 1 design involved a Shuttle deployed space tug returning a geosynchronous satellite to an orbit coelliptic (ΔH of 10 n.m) with the Shuttle, to facilitate retrieval. The Shuttle would then perform a TPI maneuver and fly a terminal phase similar to Gemini and Apollo (Fig. 1). Mission 2 was a servicing mission to an orbiting science platform.

In April of 1973, the five-maneuver profile used for Mission 2 was replaced by a Skylab based profile that satisfied Shuttle operational considerations that had been identified up to that time.

Those considerations were: 1) rendezvous with a navigationally active or passive target at orbital altitudes ranging from 150 to 400 n.m.; 2) liftoff time selected whenever coplanar launch is possible, and will not be constrained by time-of-day; 3) minimize onboard relative navigation sensor cost, operating range and accuracy; 4) ground tracking support requirements had not been clearly defined; 5) an optical sensor was required for inertial platform alignment; and 6) the phasing portion of the rendezvous was not to be unnecessarily large.

A change to the Skylab plan involved the insertion of a second coelliptic segment before the NCC burn (Fig. 2). This second

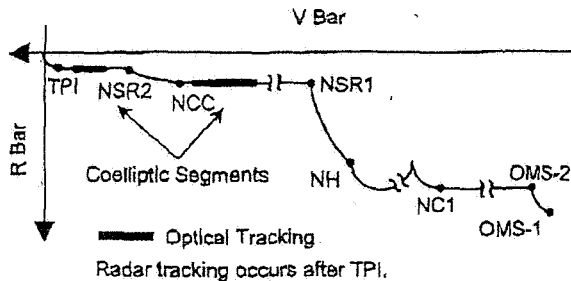

Fig. 2 Dual co-elliptic rendezvous (1973-1983).

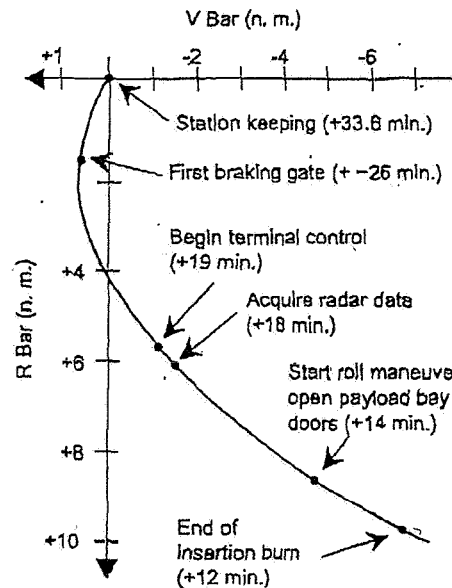

Fig. 3 Mission 3B approach (1975). Times are with respect to liftoff.

coelliptic phase allowed the subsequent maneuver points to be chosen to maximize use of reflected sunlight for optical tracking of navigationally passive targets. The additional coelliptic segment also ensured the same relative geometry from the start of optical tracking through intercept for variations in liftoff time and target orbital altitude.

Relatively constant range at the first optical tracking opportunity was also important due to the lower quality of optical tracking at this point. The dual coelliptic sequence (ΔH of 20 and 10 n.m.) also provided enough control over lighting to minimize lighting considerations for launch window determination. A wide variation in liftoff time was permitted without resulting in an excessively long phasing period. The profile also permitted flexibility in selecting the level of ground tracking required and in the selection of on-board relative navigation sensors.

The standard terminal phase (Fig. 1) was also used for Mission 2. One issue, however, was that the targets would probably not possess strobes, as other targets had in previous programs. Lighting requirements for the pre-TPI optical tracking pass and the initiation of manual piloting (a few thousand feet from the target) at sunrise drove TPI to be performed after sunset. A lack of target artificial lighting meant that the backup manual procedure of pointing the vehicle thrust axis at the target to execute TPI would not be available, as it was on many trajectories flown by Gemini and Apollo vehicles. The dual coelliptic (Fig. 2) would serve as the baseline Shuttle profile for mission planning until April of 1983.

Rendezvous For Reference Mission 3B

Mission 3B was a satellite retrieval from a 100 n.m. circular orbit, with launch and landing occurring at Vandenberg Air Force Base. Mission duration was about 2 hours.

The insertion point (Fig. 3) was chosen to place the Shuttle on a terminal trajectory with characteristics similar to those used on terminal approaches flown on Gemini, Apollo, Skylab and Apollo-Soyuz missions (Fig. 1).

Due to the short timeline (station-keeping at a range of 100 feet established ~21.6 minutes after orbit insertion), no ground tracking of the Shuttle was to be performed, nor would the Shuttle have processed relative sensor measurements in a Kalman filter. No on-board targeted maneuvers would have been performed. Radar data (range, range rate, inertial line-of-sight rates) was to have been used

by the crew to fly an approach along a straight line relative to an inertial reference frame and reduce closing velocity to appropriate levels. While similar profiles had been flown on Gemini 11 and Apollo lunar missions 14 through 17, the Mission 3B profile was much more demanding. Whether or not rendezvous, target capture with the RMS, berthing, payload bay door closure and deorbit could have been accomplished within the timeline is questionable.

Missions 3B and 3A (a similar mission, but with a deployment rather than retrieval) were the most challenging of the reference missions, and had the most impact on Shuttle systems design and performance requirements. Planning for both missions ended around 1976, and neither was flown.

VI. Plume Impingement

Identification of the Problem

Gemini and Apollo attitude control systems produced little cross coupling, and thrust magnitude, nozzle canting, target vehicle size and appendages did not result in significant plume impingement issues. Lunar Module self-impingement did have to be addressed with hardware modifications. In the early 1970s, the existence of plume impingement was controversial, but analysis of Gemini 11 film showing tether dynamics in response to RCS firings proved that plume impingement was real. During the first attempt on Skylab 2 to deploy a stuck solar array, the CSM was maneuvered so that a crewman standing in the hatch could reach the array with a deployment tool. Apollo CSM thrusting to null the closing velocity triggered Skylab jet firings to maintain attitude, which resulted in an opening rate between the vehicles.¹⁸ Later film of Apollo CSM RCS effects on the Skylab thermal control parasol triggered Russian concerns about plume impingement for the Apollo-Soyuz mission. Four of the CSM's RCS jets were inhibited within 2 seconds of contact, to avoid plume loading on the Soyuz solar arrays.²⁰

By 1973, contamination of payloads by Shuttle RCS jet effluents during the Shuttle approach and braking phase was a concern to the payload community. Previous analysis focused on potential contamination in the payload bay at the launch site and on-orbit. An approach trajectory was proposed that minimized the expulsion of combustion by-products at the target, and therefore minimized the potential for contamination (Fig. 4). The trajectory was designed under the assumption that the target spacecraft could not be designed

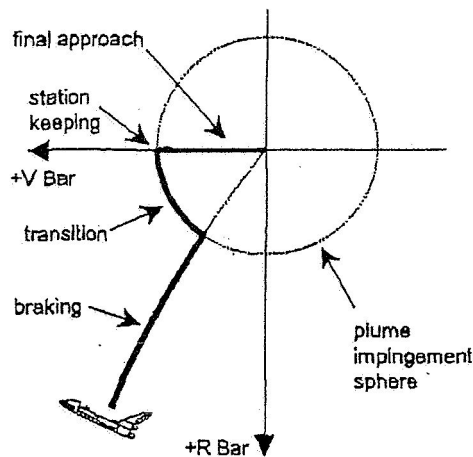

Fig. 4 Terminal approach to minimize plume impingement on target (1973).

with features to prevent contamination (such as movable sensor covers), or that control of target attitude could not prevent contamination. A target specific minimum range at which jets could be fired in the direction of the target without a contamination concern was defined. At this point the orbiter would transition from the direct approach trajectory to a station-keeping point on the target velocity vector (V Bar, see Fig. 26 in Appendix). After preparations for grapple with the RMS were complete, the orbiter would initiate the final approach to the target.

In 1975, work began on rendezvous procedures for the Long Duration Exposure Facility (LDEF, Fig. 5) retrieval and Solar



Fig. 5 LDEF being maneuvered with the RMS.

Maximum Mission satellite servicing (Fig. 6), due to an anticipated deployment of LDEF on an early Shuttle mission, and the approaching launch of Solar Max on a Delta booster. Issues arising out of these efforts were to have a profound impact on Shuttle operational concepts. The large size of the Shuttle primary RCS jets (870 pounds thrust) coupled with the small size of LDEF and Solar Max compared to the Shuttle led to more concerns about RCS plume impingement effects. Plume impingement could induce attitude rates on the target or even result in separation of the target and Shuttle. Targets with attitude control systems may not have been designed to maintain attitude in the presence of orbiter plumes. This was a particular concern for payloads that used gravity gradient stabilization, such as LDEF. Shuttle thruster sizing, placement and orientation were designed to provide adequate flight control authority throughout the Shuttle flight envelope, and to avoid self-impingement of aero surfaces, but impingement of target spacecraft or the RMS

was not factored into the design.²³

By May of 1976, plume impingement simulations using simple math models had been conducted. Results indicated that plume impingement induced dynamics at RMS release or grapple ranges could make LDEF deployment and retrieval difficult and perhaps impossible. A development effort was initiated to obtain improved models of Shuttle RCS jets and plume physics. New models were required to better characterize impingement effects and test trajectories, piloting techniques, new software, and identify vehicle hardware modifications needed to mitigate impingement effects.

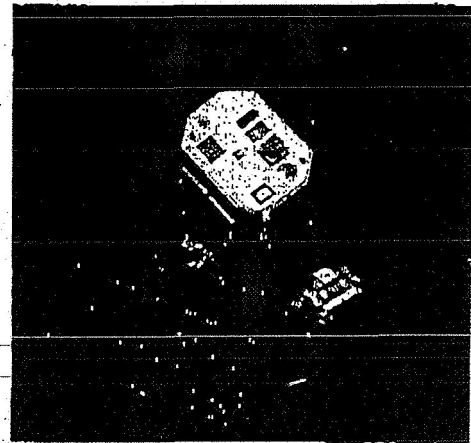

Fig. 6 Attempted retrieval of the Solar Max satellite by an astronaut flying a Manned Maneuvering Unit on STS-41C.

Resolving the Plume Impingement and Forward RCS Propellant Problems

By April of 1977, after a considerable amount of lobbying by concerned technical and management personnel, potential problems with the ability of the Space Shuttle to retrieve satellites such as LDEF and Solar Max were receiving visibility at high levels within the Shuttle Program and the payloads community external to the Program.

Some proposed solutions to the plume impingement problem, such as alternate recovery techniques using new hardware (stand-off berthing using a mast or tether), a payload bay mounted cold-gas propulsion system, and "hardened" payloads were not acceptable due to complexity and cost. Operational work-arounds consisting of new piloting techniques, and Shuttle flight control system modifications were preferred. However, these options increased propellant usage and increased complexity of crew procedures and Shuttle flight control software.

Both the Gemini and Apollo vehicles carried ample propellant margins, but the Shuttle was limited in terms of forward RCS propellant. The Shuttle could run out of forward RCS propellant during the terminal phase (Fig. 1) under dispersed trajectory conditions, and in the event of a radar failure.

At this time the term "proximity operations" or "prox ops" was coined, and proximity operations became a distinct discipline within the Shuttle Program. Proximity operations occur close to the target (within 2,000 feet), and are characterized by nearly continuous trajectory control, whereas rendezvous control maneuvers typically occur at intervals of hours or tens of minutes.

From July to September of 1977, a study of approach and station-keeping techniques was conducted in the Johnson Space Center (JSC) Systems Engineering Simulator. This was the first six degree-of-freedom simulator to incorporate plume effects. V Bar, R Bar and H Bar approaches and station-keeping were evaluated (Fig. 7). Results confirmed earlier studies, which indicated that an Apollo inertial

VII On-Board Systems

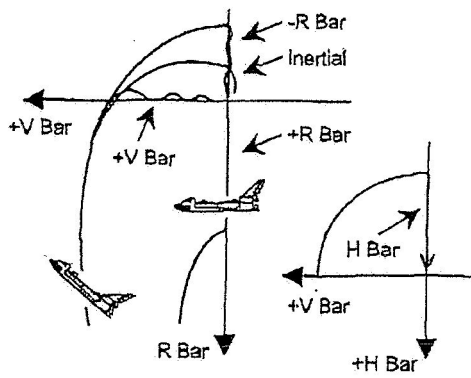

Fig. 7 Proximity operations approaches.

approach and braking technique caused the gravity gradient stabilized LDEF to tumble. The one technique that worked for approaches along all three Local Vertical Local Horizontal (LVLH) frame axes (V Bar, R Bar, H Bar) used orbiter +/-X body axis RCS jets (Fig. 8) for braking. These jets had a small component of thrust along the +Z body axis. Some +R Bar approaches worked with the Apollo approach and technique, due to the natural braking effect of orbital mechanics.

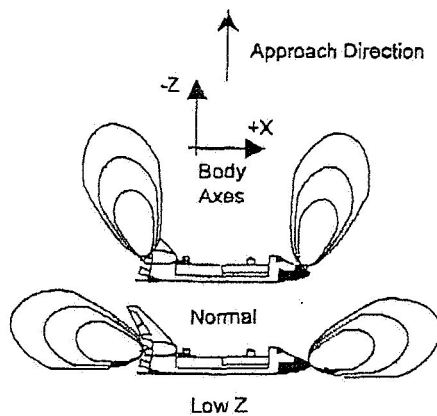

Fig. 8 Comparison of plumes.

Advantages of the H Bar approach were consistently good lighting conditions for piloting and Y LVLH motion that did not couple into the LVLH X and Z axes. Unlike the +R Bar approach, the H Bar approach did not have natural braking, but had natural acceleration, which necessitated frequent thrusting at the target during approach. Out-of-plane motion still occurred after relative translational rates were nulled. The H Bar approach was never baselined for operational use, due to safety, station-keeping, propellant consumption and plume impingement concerns.

Due to the 1977 study, the orbiter flight control system was modified to provide a "Low Z" mode. This provided some RCS braking capability while minimizing RCS plume impingement (Fig. 8). Jets used for this mode had a thrust component that was primarily along the X body axis. The serendipitous canting of the aft X axis RCS jets was not an original design requirement for proximity operations.⁷ Upward firing RCS jets were inhibited in Low Z. However, use of the Low Z mode was expensive in terms of propellant use. The ability to perform an attitude hold with respect to the LVLH frame was also added to the Shuttle flight software.

⁷ The braking contribution provided by the scarfed, nose mounted X axis RCS jets is negated by RCS firings to control pitch.

Relative Navigation Sensors

Original Shuttle rendezvous navigation requirements called for a radar range of 300 n.m., provided that the target was equipped with a transponder. Skin tracking (no transponder) of a target with a 1 square meter cross section out to a range of 10 n.m. would be available as a contingency mode of operation.²⁴

Radar development costs led to examination of deferral of radar operational capability, which would have resulted in many early rendezvous missions not having radar. The cost of Ku band radar development also motivated the study of alternative sensors. "All optical rendezvous" was studied, but simulations indicated that the probability of successful dual coelliptic rendezvous (Fig. 2) under dispersed conditions was less than desirable. Use of Shuttle entry Tactical Air Navigation (TACAN) units for rendezvous was also studied, but not pursued. This would have involved mounting a TACAN transmitter on target spacecraft.

The decision to proceed with Ku radar development was in part motivated by concerns about the proposed Skylab reboost mission. Cost overruns prevented the acquisition of target transponders and spare parts for the Shuttle radar, and the passive skin tracking mode of radar operation was adopted (Fig. 9), which in turn limited the range of the radar. This was a factor in the inability of the Shuttle to meet rendezvous autonomy requirements. The Ku antenna and electronics would also be used for communications through the Tracking and Data Relay Satellite (TDRS).

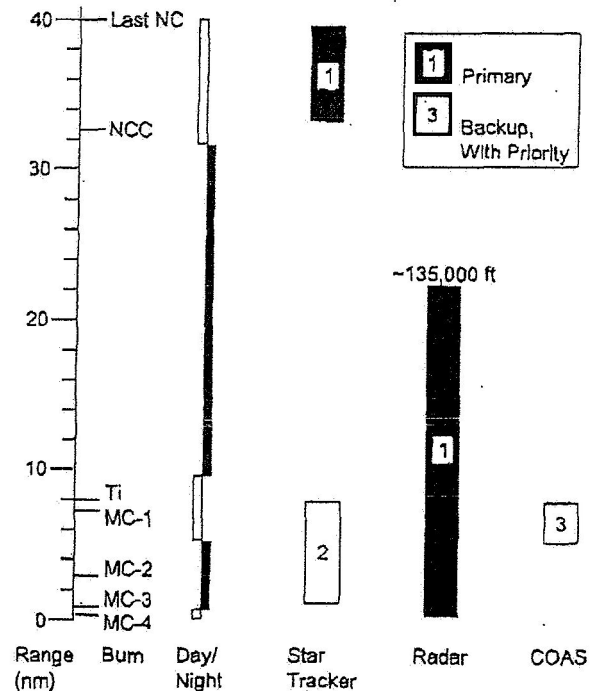

Fig. 9 Operational use of Shuttle rendezvous sensors for a typical ISS mission.

Optical tracking would be provided by one of two star trackers, which were also to be used for aligning the Inertial Measurement Units.²⁵ The trackers had field of view restrictions based on Earth limb and bright object considerations (Sun, Moon). Availability of optical measurements, which used target reflected sunlight to facilitate acquisition and tracking, was seen as a major challenge. Strobes, used on targets in previous programs for optical tracking via the human eye, were judged to be incompatible with the Shuttle star trackers.

As a back-up to the radar and star trackers, a Crew Optical Alignment Sight (COAS) could be used to obtain angular measurements. The COAS would later see extensive use during proximity operations (Fig. 10).²¹

Relative navigation sensor measurements from the radar, star tracker and COAS are processed in a Kalman filter that built upon the Apollo experience.^{26,27} Original filter requirements called for an optimal filter that updated both the Shuttle and target state vectors, but the 1976 on-board computer requirements scrub resulted in the filtering of only one state vector, as was done on Apollo.²⁸

Beginning in the mid 1970s, there were concerns about the lack of a back-up range and range-rate measurement device for the Ku band rendezvous radar, particularly during proximity operations or the proposed Skylab re-boost mission. A number of potential



Fig. 10 EVA crewman on the RMS attempts to capture INTELSAT (right). The COAS is on the left (STS-49, 1992).

off-the-shelf solutions were examined. A laser rangefinder was flown on STS-41B and STS-41C (1984), but limitations in range and accuracy limited their usefulness. A parallax rangefinder and a night vision system were also tested on early missions, but performance was not adequate. COAS subtended angle is available for range determination using charts at close range.

During the late 1970s, use of the Global Positioning System (GPS) was examined, but not adopted due to cost and the immaturity of the technology.²⁹ On-board processing of TDRS Doppler measurements to reduce dependency on ground radar tracking was also studied, but not pursued due to on-board computer limitations.

Maneuver Targeting

The ground-targeted phase for orbital control begins after orbit insertion. Rendezvous maneuvers are computed by Mission Control using orbit determination data obtained by processing ground radar and TDRS Doppler measurements. The length of this phase varies, and typically lasts several days. Although a ground-targeted phase maneuver plan is determined before launch, some adjustments are required after launch due to Shuttle ascent performance dispersions, or Shuttle or target spacecraft systems problems.

The on-board targeted phase begins once Shuttle sensors (the first is star tracker, Fig. 9) are able to obtain relative measurements. Shuttle orbit adjustments are then computed on-board, while Mission Control computations are available as a back-up, in the event of an on-board system anomaly. Unlike the ground-targeted phase, activities from the beginning of on-board relative navigation to the beginning of proximity operations (at a range of ~2,000 feet) may change little from flight to flight.

The original (1972 through 1976) on-board targeting package was called the Orbit Maneuver Processor (OMP). The OMP concept was based on Apollo on-board and ground based targeting. OMP was

more flexible than its predecessors and could support different combinations of burns without reprogramming. It was also capable of targeting all orbital maneuvers from insertion through intercept.

In 1974, a requirement for the Shuttle to conduct autonomous rendezvous (little or no support from Mission Control) existed. Astronauts were to compute a nominal series of maneuvers and execute them without Mission Control confirmation. For off-nominal scenarios, the crew could compute and execute a rendezvous plan with inputs from checklists or Mission Control. The on-board computer would not recommend actions in response to off-nominal situations. Mission Control was still to be able to compute maneuvers, particularly in the event of off nominal scenarios. However, limited on-board computer capacity made the requirement difficult to meet. A 1976 on-board targeting requirements scrub in response to computer limitations moved computation of burns not supported by on-board relative navigation to Mission Control. This move also reduced OMP implementation costs.

In order to lower forward RCS propellant consumption, it was believed that during proximity operations the orbiter should be able to approach a target from any direction (Fig. 7). This would provide maximum flexibility during mission planning. A proximity operations targeting package based on the Clohessy-Wiltshire equations was formulated. However, limitations in Shuttle computer capacity would not permit inclusion of both the proximity operations targeting and the already scrubbed down OMP for rendezvous targeting. Scrubbing the remaining OMP software was one option, but studies indicated that the Clohessy-Wiltshire targeting package might not be able to adequately support maneuvers with longer transfer times, such as TPI. The scrubbed down OMP was replaced by a Lambert targeting option to support longer transfer times. The original pre-scrub OMP became the basis for the Shuttle maneuver targeting software in Mission Control.

On-board orbiter state vectors used by Lambert and Clohessy-Wiltshire targeting are updated with radar, star tracker and COAS measurements. Lambert targeting was used for all rendezvous missions, while the Clohessy-Wiltshire option was never used in flight.³⁰

Grapping Hardware

The RMS is an approximately 50 foot long, six degree-of-freedom arm equipped with six joints (shoulder yaw, shoulder pitch, elbow pitch, wrist pitch, wrist yaw, and wrist roll). It is located on the port side of the payload bay, and is capable of handling payloads up to 65,000 pounds. The RMS end effector on the end of the arm grapples a fixture installed on the payload. An RMS display and control panel, rotational and translational hand controllers, and associated television displays are located in the aft flight deck flight crew station. A starboard arm was also planned in the 1970s, but was never flown. In addition to deployment and retrieval of satellites and free-flying scientific payloads, the RMS is also used as an extension ladder for EVA crews (Fig. 10), for positioning modules during ISS assembly and replenishment, and for conducting orbiter and ISS inspections using television cameras and other sensors.

VIII Coelliptic Versus Stable Orbit Rendezvous

The Stable Orbit Profile

Although the dual coelliptic (Fig. 2) had been baselined for mission planning purposes in 1973, doubts about its capability to support Shuttle rendezvous missions persisted into the early 1980s. The ability to obtain sufficient on-board optical tracking using reflected sunlight, in the presence of Earth limb and celestial bright object constraints on the field of view was questionable. By 1978, forward RCS propellant depletion due to the high relative approach velocity inherent with coelliptic was a serious concern.

In 1975, theoretical studies of the stable orbit profile (first studied from 1962-1964, and first flown on Gemini 11⁸⁻¹⁵) were again performed. Stable orbit involved the initiation of the intercept from a station-keeping point on the $-V$ Bar, rather than from a coelliptic orbit (Fig. 1). Stable orbit might simplify flight design and operations for missions involving deployment of a satellite, followed by retrieval of a second satellite. Contingency retrieval of a deployed payload might also be easier to perform with stable orbit. A stable orbit profile would desensitize the mission timeline from trajectory considerations. Stable orbit, long-range station-keeping (tens of miles) was preferable to close range station-keeping (tens or hundreds of feet), due to the need for continuous crew monitoring and resulting propellant expenditure. However, like dual coelliptic, the availability of sufficient tracking on a stable orbit profile for a navigationally passive target was in question.

By 1981, mission design for the LDEF deployment and Solar Max repair mission (later flown on STS-41C in 1984) was encountering difficulties. Mission planners began to adapt the stable orbit concept to overcome propellant depletion, mission timeline and on-board tracking issues with the dual coelliptic profile (Fig. 1).

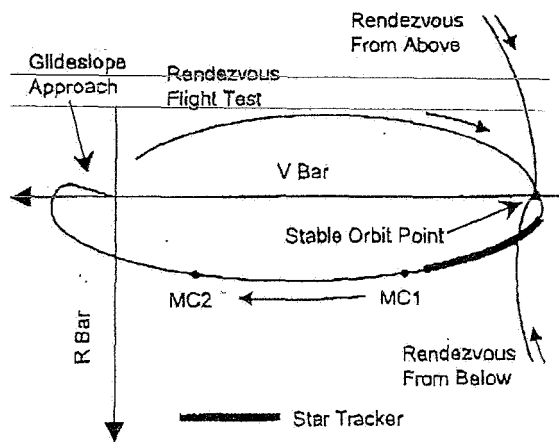

Fig. 11 A proposed stable orbit rendezvous profile (1982).

It was suggested that ground radar tracking and Mission Control computed burns could place the Shuttle at a point on the $-V$ Bar, and at or within the rendezvous radar 10 n.m. range specification. Station-keeping at the stable orbit point would be performed until orbital noon, at which point the Shuttle would initiate an intercept trajectory with an on-board targeted burn. The station-keeping and the timing of the transfer would also provide control over lighting in the manual piloting phase. Station-keeping could also be extended in the event of Shuttle or target systems problems. In the event of a radar failure, optical tracking could be performed. A station-keeping point of 8 n.m. was selected. This was inside radar range, but far enough away to avoid potential target size and brightness problems with the Shuttle star trackers. Closing rates during braking were an order of magnitude lower than the dual coelliptic, which lowered propellant consumption.

The Tuned Coelliptic Profile

To address concerns with the dual coelliptic profile, coelliptic advocates designed an alternate called the "tuned" coelliptic (Fig. 12). All day-of-rendezvous burns would be on-board targeted, with a maximum star tracker tracking range of about 150 n.m. The coelliptic ΔH was much lower than the second dual coelliptic ΔH (2.5 versus 10 n.m.). The lower ΔH permitted radar acquisition of the target before TPI, and provided an overlap in radar and star tracker tracking for comparison purposes. Increasing the transfer angle lowered the

terminal phase relative velocity, which in turn lowered propellant consumption during braking. However, the lower ΔH also increased the variability in the time at which the desired TPI relative geometry (elevation angle) was achieved (Fig. 1). The profile could be tuned during the mission to control slips in TPI time and trajectory dispersions. Adjusting the placement of early phasing maneuvers increased the number of tracking periods prior to the coelliptic maneuver, and decreased TPI sensitivity to burn dispersions.

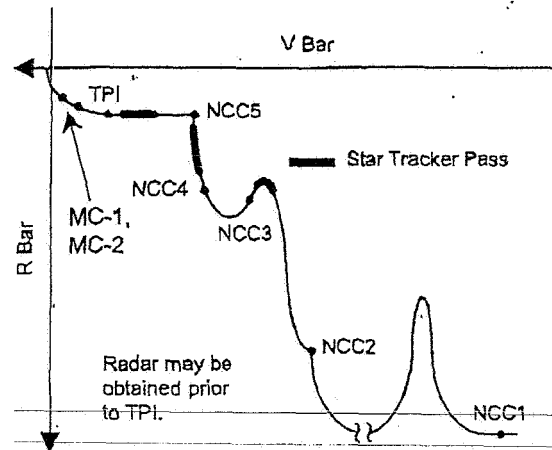

Fig. 12 Tuned coelliptic rendezvous with a ΔH of 2.5 nautical miles (1982).

Selection of a New Baseline Profile

A lengthy debate ensued between stable orbit proponents and coelliptic supporters. The debate involved some of the same personnel that had been involved in the coelliptic versus tangential versus first apogee rendezvous debate during mission planning for Gemini VI in 1964.⁹ Coelliptic was a proven technique, and some Mission Control personnel, as well as some astronauts, were not in favor of adopting a new profile. Mission planners believed stable orbit provided several advantages over tuned coelliptic; lower propellant consumption, less complex crew and Mission Control procedures, stable station-keeping points on the $-V$ Bar in the event of a systems anomaly or change in mission planning, and elimination of the need to perform optical tracking with star trackers. However, pilot-in-the-loop simulations indicated that stable orbit procedures were just as complex as tuned coelliptic. Stable orbit potentially offered more straightforward trajectory design for flights requiring rendezvous from in front or above (Fig. 11). Like stable orbit, tuned coelliptic could be designed with a delay option, but with higher propellant consumption and increased procedural complexity.

Analysis of the stable orbit plan revealed a number of weaknesses, which were corrected by changing the profile. Station-keeping on the $-V$ Bar at the 8 n.m. stable orbit point was eliminated in favor of performing the intercept maneuver, called Transition Initiation (Ti¹), when the 8 n.m. point on the $-V$ Bar was reached. In the event of a systems anomaly, an equal period "football" trajectory could be initiated at Ti ("Ti delay") until it was permissible to continue the rendezvous.

Several variations of terminal phase were studied. In one, Ti was targeted to place the Shuttle several miles in front of the target on the $+V$ Bar, after which the Shuttle would move in along the $+V$ Bar. In another, Ti targeted the Shuttle for a point 5000 feet ahead of the target and 1500 feet above it. From there, the Shuttle would fly a "glideslope approach" (Fig. 11), which avoided RCS firings that

¹ In the acronym "Ti," the "i" for initiation is not capitalized to avoid confusion with another rendezvous acronym used in the Shuttle Program.

could impinge on the target.³¹

As analysis progressed, four Mid-course Correction (MC) burns were placed between Ti and intercept. A planar change maneuver (null out-of-plane velocity) was placed at the nodal crossing following MC-1. To reduce the size of the out-of-plane velocity null after MC-1, on-board tracking was extended before Ti to include one or two star tracker passes, starting at a range of 40 n.m. This created an overlap of ground and on-board tracking for cross checking before committing to an intercept trajectory. An additional on-board burn prior to Ti, NCC, was added to ensure that the Ti point would be in the orbital plane of the target.^{21,30}

Stable orbit was adapted as the Shuttle baseline rendezvous plan in April of 1983 (Fig. 13), during planning for mission STS-41C. Factors influencing the decision were the inability of the Mission Control software (OMP) to support the tuned coelliptic without modification, and that the stable orbit concept was promoted by the ISC organization responsible for trajectory design and mission planning. In the event that a second rendezvous with a target was required, stable orbit potentially incurred lower propellant expenditure than tuned coelliptic.

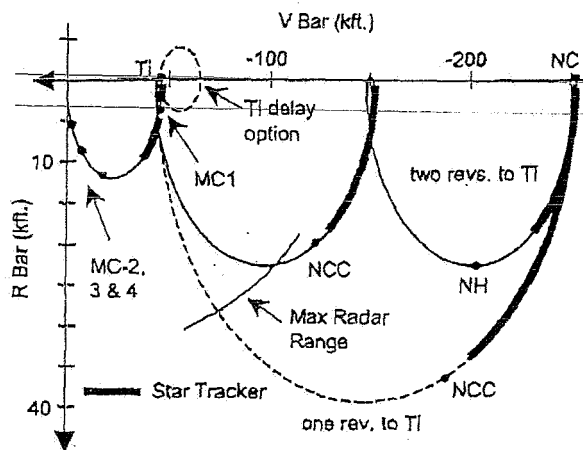

Fig. 13 Stable orbit rendezvous (1983-1997).

Shuttle Flights (1983-1998)

First Proximity Operations and Rendezvous Flights

After the first flight of the Space Shuttle (STS-1) in April of 1981, and successful demonstrations of the RMS on subsequent flights, more personnel, computer resources and simulator time became available for rendezvous and proximity operations procedure development, trajectory analysis and issue resolution.³² STS-7 (June 1983) performed a proximity operations demonstration using the Shuttle Pallet Satellite (SPAS-01).^{33,34} Primary objectives were to demonstrate and evaluate proximity operations techniques required for deployment, separation, station-keeping, final approach and RMS capture of a free-flying payload. No computer based maneuver targeting or relative navigation data using computer processed radar measurements was available. Out-the-window cues and radar data direct from the sensor were used. Results indicated that plume impingement math models were accurate, the rendezvous radar performed better than expected, piloting using out-the-window cues and radar data was easily accomplished, and that the proximity operations tasks could be accomplished with propellant consumption falling within one sigma of predicted values. The Low Z and LVLH attitude hold flight control options were proven effective.

The first rendezvous demonstration was planned for STS-41B (February 1984), the tenth Shuttle mission. However, the rendezvous was canceled after the Integrated Rendezvous Target balloon burst

during deployment from the Shuttle payload bay.

The Solar Max repair mission (STS-41C, April 1984, Fig. 6) was the first "all up" use of the Shuttle's integrated rendezvous and proximity operations capabilities. These included pre-flight trajectory design, launch window targeting, ground targeting using radar-based orbit determination, deployment of a payload (LDEF, Fig. 5) during the ground-targeted phase, onboard rendezvous navigation with a navigationally passive target, onboard rendezvous targeting, and three body proximity operations involving *Challenger*, Solar Max, and an astronaut flying the Manned Maneuvering Unit.

The first attempt to capture the Solar Max with an astronaut flying the MMU failed, and a break-out maneuver was performed to take *Challenger* safely away from Solar Max. Enough propellant margin was available to perform a second rendezvous two days later, and -V Bar station-keeping 40 n.m. from Solar Max was performed until the second rendezvous was initiated. A previously developed backup capture procedure using the RMS was used to successfully grapple Solar Max.

The successful execution of proximity operations on STS-7 and STS-41C and two rendezvous profiles on STS-41C validated work performed over a decade to create piloting techniques and trajectories that overcame Shuttle systems limitations, and allowed the Shuttle to meet mission requirements different from those in the Gemini and Apollo programs.

Challenges of Subsequent Rendezvous and Proximity Operations Missions

The success of STS-7 and STS-41C did not mean that later Shuttle rendezvous and proximity operations missions were in any way "routine." The unique characteristics of the various rendezvous targets, along with Shuttle system limitations, posed technical challenges for every rendezvous mission, and necessitated mission unique analysis and procedure development. Complexity of, and variation in procedures and techniques for Shuttle rendezvous and proximity operations missions was far greater than during Gemini and Apollo.

The pace of rendezvous flights between STS-41C (April 1984) and the *Challenger* accident (January 1986) had not been seen since the Gemini flights in 1965 and 1966.⁸⁻¹⁵ The success of these complex missions reflected the maturity of Shuttle rendezvous and proximity operations planning and execution. The loss of *Challenger* eliminated many potential commercial missions involving rendezvous and proximity operations, such as Leasecraft and the Industrial Space Facility. After the accident, rendezvous missions resumed in 1990. Missions executed included retrieval and return to Earth of orbiting satellites, deployment and retrieval of scientific payloads, and servicing of spacecraft.³⁵

Proximity operations and ground targeted phase trajectory design varied from flight to flight, and was driven by many factors that required extensive analysis and contingency procedure (Mission Control and on-board) development, particularly if the flight involved more than one deploy/retrieve payload. Maneuver planning to provide adequate spacecraft separation for ground radar tracking, spacecraft to spacecraft communication links and protection against collision under dispersed trajectory conditions was particularly challenging. By 1990, the availability of ground based processing of TDRS Doppler measurements and near continuous TDRS communications coverage enhanced orbit determination and mission activities.

Radar failure procedures for use during the on-board targeted phase (for most flights, approximately 40 n.m. behind the target through manual takeover at ~2,000 feet) were continually improved to maximize probability of mission success. This was demonstrated during the STS-92 (2000) rendezvous with the ISS, due to a radar failure before the day of rendezvous. The rendezvous was performed

with star tracker data until laser data became available several thousand feet from the ISS. This was the first "all optical" rendezvous flown by NASA since Apollo 7 in October of 1968.

The ground-targeted phase of two flights (STS-49 in 1992 and STS-72 in 1996) used a control box rendezvous technique (Fig. 14).³⁶ The target executed a series of maneuvers after the Shuttle was launched to enter a "control box" in space at a designated time. This technique reduced Shuttle propellant consumption. Once the target entered the box, it no longer maneuvered. A Shuttle planar change (NPC) burn could also be performed to compensate for target planar error introduced by target phasing maneuvers.

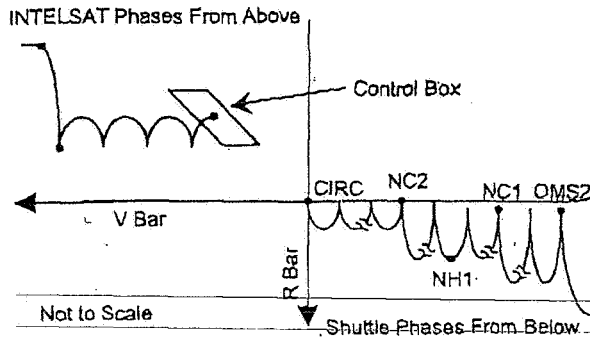

Fig. 14 STS-49 planned relative motion until control box start time (1992).

Rendezvous or Proximity Operations Technique Demonstration Missions

The previously mentioned STS-7 and STS-41C were the first demonstrations of the Shuttle's proximity operations and rendezvous capabilities (Table 2). The Orbital Experiments Digital Autopilot (OEX DAP) was an experimental proximity operations autopilot tested on STS-51G (1985) and STS-61B (1985). The autopilot was not incorporated into the Shuttle's certified avionics system. STS-37 tested long-range station-keeping using star tracker measurements while flying an out-of-plane profile using the previously deployed Gamma Ray Observatory as a target. This technique was proposed for flights with station-keeping distances constrained by communications requirements.

Table 2 Rendezvous or Proximity Operations Demonstration Missions

Flight	Orbiter	Year	Profile	Target	Comments
7	Challenger	1983	Deploy/Retrieve	SPAS-01	Proximity operations only.
41B	Challenger	1984	Deploy/Rendezvous	IRT	No rendezvous due to IRT balloon failure.
51G	Discovery	1985	Station-Keeping	none	Station-keeping test of proximity operations autopilot.
61B	Atlantis	1985	Deploy/Station-Keeping	radar reflector	Station-keeping test of proximity operations autopilot.
37	Atlantis	1991	Deploy/Rendezvous	GRO	GRO used as target for optical navigation test.

GRO = Gamma Ray Observatory, IRT = Integrated Rendezvous Target, SPAS = Shuttle Pallet Satellite

Table 3 Satellite Servicing Missions

Flight	Orbiter	Year	Target	Comments
41C	Challenger	1984	Solar Max	Retrieved and repaired after second rendezvous.
51D	Discovery	1985	SYNCOM IV-3	Contingency rendezvous after deployment and activation failure.
51I	Discovery	1985	SYNCOM IV-3	Rendezvous & EVA planned in four months. Elliptical orbit.
49	Endeavour	1992	INTELSAT VI (F-3)	Hybrid Control Box, three rendezvous.
61	Endeavour	1993	Hubble	Servicing Mission 1
82	Discovery	1997	Hubble	Servicing Mission 2
103	Discovery	1999	Hubble	Servicing Mission 3A
109	Columbia	2002	Hubble	Servicing Mission 3B

EVA = Extra Vehicular Activity, INTELSAT = International Telecommunications Satellite, SYNCOM = Synchronous Communication

Satellite Servicing Missions

Satellite servicing missions flown by the Shuttle (Table 3) required close coordination and planning between rendezvous personnel, proximity operations personnel, Extra Vehicular Activity (EVA) specialists, satellite manufacturers and satellite operators. EVA preparation and execution occurred simultaneously with rendezvous and proximity operations tasks. The previously mentioned Solar Max repair (STS-41C) was the first servicing mission.

After deployment of the SYNCOM IV-3 satellite by *Discovery* on STS-51D (April 1985), a contingency rendezvous was conducted as the SYNCOM failed to activate. Due to the failure of the activation work-around (an improvised "flyswatter" on the RMS to flip a switch), *Discovery* rendezvoused again with SYNCOM on STS-51I (August-September 1985), after deploying three satellites. Mission planning was further complicated by a circular deploy orbit for the three satellites and subsequent rendezvous with the SYNCOM in an elliptical orbit. SYNCOM was successfully activated. However, inadvertent plume impingement of the SYNCOM complicated the retrieval.

Retrieval and repair of the INTELSAT-VI (603) communications satellite by *Endeavour* on STS-49 (1992) was perhaps the most dramatic servicing mission. Difficulties with the capture bar (manipulated by an astronaut mounted on the end of the RMS, Fig. 10) prevented retrieval of the INTELSAT. After a breakout, a second rendezvous was flown, with another failed capture attempt. During the third rendezvous, an on-board Lambert targeting anomaly forced the crew to fly a Ti-Delay profile for one revolution (Fig. 13). The rendezvous was subsequently resumed and Mission Control used navigation data from the Shuttle computers to perform targeting for subsequent maneuvers on the ground. The capture was finally performed with three EVA crewmen capturing the INTELSAT by hand. STS-49 set a new Shuttle record for the number of rendezvous profiles flown (three) and the total amount to proximity operations time (~8 hours) in one mission.

Between 1993 and 2002 four missions were flown to successfully service the Hubble Space Telescope (HST). These complex servicing missions enhanced and ensured the ability of HST to provide significant scientific data and breathtaking photography.³⁷

Deploy and Retrieval of Scientific Payloads

Sixteen missions were flown involving the deployment and retrieval of from one to two science packages (Table 4). The eight types of deploy/retrieve payloads flown concerned astronomy, space physics, atmospheric physics (Fig. 15), and missile defense research support.^{38,39} Parallel execution of deploy/retrieve profiles, satellite deployments, EVAs, and multiple research tasks coordinated with multiple ground facilities made these the most complex of the Shuttle missions to plan and execute. Dual shift, 24-hour crew operations on some missions further complicated planning and real-time operations.

During STS-51F (1985) the Plasma Diagnostics Package (PDP) experiment explored the plasma environment around *Challenger*. The mission required the development of complex nominal and contingency (such as radar fail and delayed deploy) procedures, and close coordination with scientific investigators. Precise proximity operations burn targeting was performed using the Shuttle computer's Lambert targeting algorithm. An abort-to-orbit due to the shutdown of a main engine during ascent resulted in a lower orbital altitude, forcing a redesign of on-board Lambert targeting data by Mission Control. The challenging trajectory was successfully flown (Fig. 16), but the third orbit of *Challenger* about the PDP was canceled due to increased propellant consumption during ascent.

STS-39 (1991) involved a complex, 38 hour profile to support observation of orbiter Orbital Maneuvering System (OMS) burns at points 1.2 and 5.4 n.m. behind the Infrared Background Signature Survey (IBSS) spacecraft (Fig. 17a). Two Chemical Release Observation (CRO B and C) sub-satellites were deployed during the IBSS detached operations, and a third (CRO A) was deployed after IBSS was retrieved. Mission planning, dual shift crew operations and observations by ground stations were coordinated. While the mission was successful, the flown trajectory differed substantially from pre-mission planning (Fig.17b), due to complexities involving orbit determination, atmospheric variation, and unmodeled propulsive effects of the Shuttle and IBSS vehicles.

On STS-77 (1996), in addition to a deploy/retrieve of an astronomy payload with an inflatable antenna (SPARTAN 207), three station-keeping and three re-rendezvous profiles were flown with the Aerodynamically-Stabilized Magnetically-Damped Satellite (PAMS STU). The PAMS STU rendezvous profiles were specifically

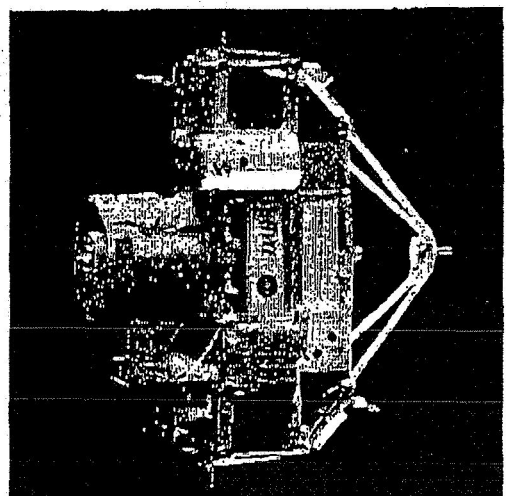

Fig. 15 CRISTA-SPAS prior to retrieval with the RMS (STS-85, 1997).

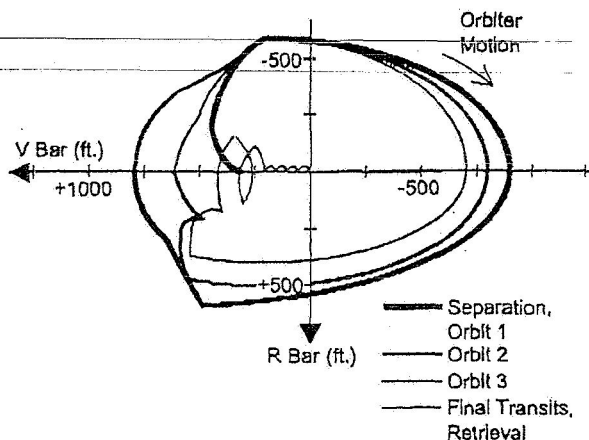
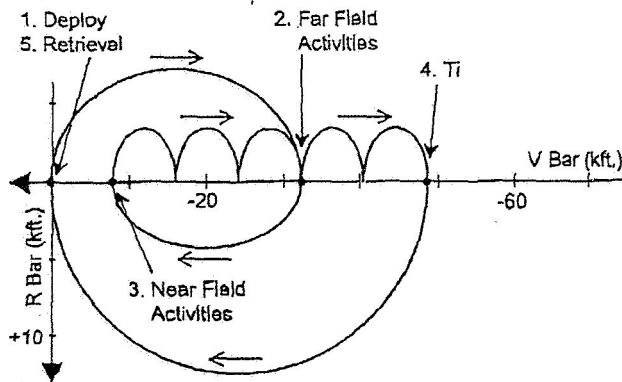

Fig. 16 STS-51F in-plane relative motion with PDP (1985).

Table 4 Deployment and Retrieval of Scientific Payloads

Flight	Orbiter	Year	Target	Comments
51G	Discovery	1985	SPARTAN-101	Incorrect SPARTAN attitude at retrieval.
51F	Challenger	1985	PDP	On-board targeted proximity operations.
39	Discovery	1991	IBSS-SPAS II	Most complex deploy/retrieve profile flown.
56	Discovery	1993	SPARTAN-201-01	Laser range and range rate sensor test.
51	Discovery	1993	ORFEUS-SPAS 1	Long range, in-front and behind station-keeping.
60	Discovery	1994	WSF-1	WSF-1, problems prevented deployment.
64	Discovery	1994	SPARTAN-201-02	First successful test of Trajectory Control Sensor laser.
66	Atlantis	1994	CRISTA-SPAS 1	Football for data collection. +R Bar Mir approach corridor test.
63	Discovery	1995	SPARTAN-204	Deploy day after Mir rendezvous. Trajectory designed to avoid Mir.
69	Endeavour	1995	SPARTAN-201-03	Incorrect SPARTAN attitude at retrieval.
			WSF-2	Long range, in-front station-keeping.
72	Endeavour	1996	OAST-Flyer	Gas venting by an experiment complicated ground tracking.
77	Endeavour	1996	SPARTAN-207-IAE	Inflatable Antenna Experiment (IAE)
			PAMS-STU	Three rendezvous and station-keeping (650 meters on -V Bar) periods.
80	Columbia	1996	ORFEUS-SPAS 2	Relative GPS test for ISS ESA Automated Transfer Vehicle.
			WSF-3	Long range, in-front station-keeping.
85	Discovery	1997	CRISTA-SPAS 2	Tested ISS +V Bar corridor approach using payload bay keel camera.
87	Columbia	1997	SPARTAN-201-04	SPARTAN activation failure, EVA retrieval. Video Guidance Sensor test.
95	Discovery	1998	SPARTAN-201-05	Video Guidance Sensor test.

CRISTA = Cryogenic Infrared Spectrometers and Telescopes for the Atmospheric, ESA = European Space Agency, GPS = Global Positioning System, IBSS = Infrared Background Signature Survey, OAST = Office of Aeronautics and Space Technology, ORFEUS = Orbiting and Retrievable Far and Extreme Ultraviolet Spectrometer, PAMS-STU = Passive Aerodynamic-Magnetically Stabilized Satellite Test Unit, PDP = Plasma Diagnostics Package, SPARTAN = Shuttle Pointed Autonomous Tool For Astronomy, SPAS = Shuttle Pallet Satellite, WSF = Wake Shield Facility



a) Planned Profile

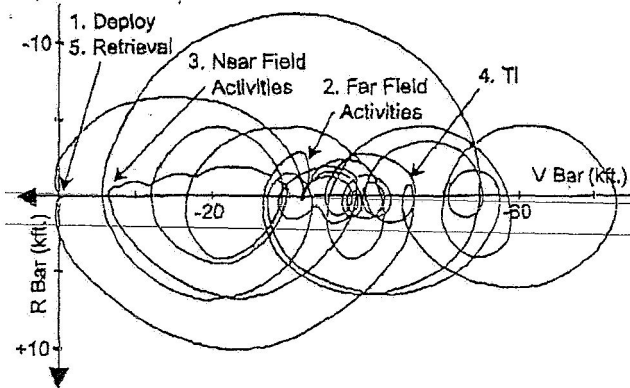

b) Flown Profile

Fig. 17 STS-39 IBSS Detached Activities (1991).

designed and flown to collect data for the experiment. The PAMS STU was not retrieved.

After deployment from *Columbia* on STS-87 (1997), the SPARTAN-201 free-flyer failed to activate preventing accomplishment of science objectives and forcing a "by hand" retrieval later in the mission by astronauts during an EVA. The SPARTAN was successfully deployed and retrieved the next year on STS-95. The Video Guidance Sensor (VGS), an experimental proximity operations sensor, was tested on both flights with the SPARTAN. An improved version of VGS, called the Advanced Video Guidance Sensor, was later developed for the Demonstration of Autonomous Rendezvous Technology (DART) and Orbital Express programs.

An example of mission-specific trajectory design were the Wake Shield Facility (WSF) flights (Fig. 18 and Table 4). The WSF structure created an enhanced vacuum on the downwind side of the vehicle to support thin film epitaxial growth and materials purification. Long-range station-keeping was performed ahead of the WSF, rather than behind, to avoid WSF contamination by Shuttle

RCS firings and water dumps. There was also a requirement for the payload bay to be visible to the WSF for communications purposes. Extended station-keeping with the orbiter windows and radiators pointed opposite the velocity vector (toward the WSF) was also desirable to minimize orbital debris impacts on those surfaces.

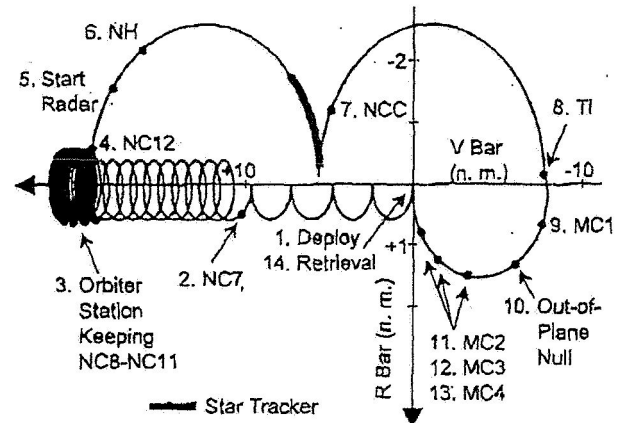

Fig. 18 STS-80 deploy/retrieve profile for the Wake Shield Facility (1996).

Several deploy/retrieve missions were used to evaluate relative GPS technology for application to future rendezvous vehicles. During STS-69 (1995), *Endeavour* carried a Collins 3M receiver and the Wake Shield Facility a Osbourne/Iet Propulsion Laboratory TurboRogue receiver. On STS-80 (1996), *Columbia* carried a TANS Quadrex receiver and the ORFEUS-SPAS II a Laben Tensor receiver in support of the European Space Agency (ESA) Automated Transfer Vehicle (ATV) program.

Retrieval and Return to Earth of a Satellite

Discovery on STS-51A (1984) successfully retrieved the Palapa-B2 and Westar-VI communications satellites only nine months after Payload Assist Module failures prevented them from achieving their service orbits (Table 5). STS-51A demonstrated the ability of the Shuttle Program to rapidly respond to new requirements involving target vehicles not designed to support Shuttle activities.⁴⁰ Planning for the dual rendezvous mission was further complicated by the deployment of two other communications satellites prior to the rendezvous and servicing phase, and the combination of proximity operations with free-flying (MMU) EVA crew capturing and maneuvering the satellites for grapple using the RMS. Detailed mission preparation and real-time re-planning enabled the rendezvous with, retrieval and return to Earth of the satellites within a tight propellant budget. Both Palapa-B2 and Westar-VI maneuvered to meet downrange and planar offset conditions before the launch of *Discovery*.

STS-32 (1990) successfully retrieved LDEF (Fig. 5), after it had spent nearly six years on-orbit. LDEF orbital decay due to the solar maximum, variation in decay rate due to variable solar flux,

Table 5 Retrieval and Return to Earth of a Satellite

Flight	Orbiter	Year	Target	Comments
51A	Discovery	1984	Palapa-B2 Westar-VI	Both maneuvered to meet downrange and planar constraints and retrieved by an astronaut flying the MMU.
32	Columbia	1990	LDEF	Hot final approach due to radar procedure issue.
57	Endeavour	1993	EURECA (ESA)	Solar array latch failure, corrected during EVA.
72	Endeavour	1996	SFU (Japan)	Hybrid control box. Solar array retraction failure & jettison.

LDEF = Long Duration Exposure Facility, EURECA = European Retrievable Carrier, EVA = Extra Vehicular Activity, MMU = Manned Maneuvering Unit, SFU = Space Flyer Unit

Columbia launch delays and the SYNCOM IV-5 deploy two days before the rendezvous complicated mission planning. Orbit prediction of the LDEF had a high degree of uncertainty, and experience with Skylab in 1978 and 1979 heightened concerns that LDEF could reenter the atmosphere before retrieval. During the rendezvous, poor quality radar data at long range resulted in a dispersed trajectory, and a faster final approach that required additional braking.

The European Retrievable Carrier (EURECA), deployed on STS-46 (1992), was retrieved on STS-57 (1993). EURECA completed an orbit adjustment program in preparation for the rendezvous seven days prior to the launch of *Endeavour*. A phase repeating orbit was used to establish periodic launch windows and ease mission planning. In the event of an off-nominal Shuttle orbit insertion, plans were developed for EURECA to lower its orbital altitude to facilitate a rendezvous and retrieval.⁴¹

STS-72 (January 1996) retrieved the Japanese Space Flyer Unit (SFU), which had been launched from the Tanegashima Space Center by an H-2 booster on March 18, 1995. The two SFU solar arrays were jettisoned before retrieval when sensors indicated improper latching after array retraction.

IX. Mir and the International Space Station

Docking of the Space Shuttle with notional space stations was studied in the early 1970s, as well as docking in support of space rescue motivated by the Apollo/Soyuz Test Project. Much of the work done to prepare the Shuttle to support Space Station Freedom was applied to the Mir and ISS missions (Tables 6 and 7).

Docking Hardware

The Androgynous Peripheral Docking Assembly-89 (APAS-89) unit (Fig. 19) is a descendent of the APAS-75 unit jointly developed by the Soviet Union and the U.S. for the Apollo/Soyuz Test Project. APAS-89 was originally intended for use on a Soyuz class vehicle and the *Buran* shuttle. Soyuz TM-16 (January-February 1993) docked with one of the two Kristall Mir module ports equipped with the APAS-89. For the U.S. Shuttle, the APAS-89 is mounted on the Orbiter Docking System (ODS) in the payload bay. APAS-89 was used for dockings to both Mir and ISS. A centerline camera mounted in the ODS with a bore sight through the ODS hatch window provides the Shuttle crew with a view of a docking target mounted on the Mir and ISS hatches.⁴²

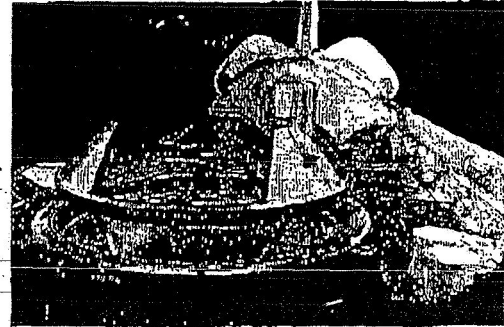

Fig. 19 APAS-89 on the Orbiter Docking System in the payload bay. The RMS is on the right.

Table 6 Space Shuttle Flights to Mir

Flight	Orbiter	Year	Comments
63	Discovery	1995	+V Bar approach to 37 feet. No docking planned. Leaking RCS jet problem.
71	Atlantis	1995	Docked to Buran port on Kristall Module. Crew exchange.
74	Atlantis	1995	Installed Shuttle Docking Module on Kristall.
76	Atlantis	1996	Resupply & U.S. crew delivery.
79	Atlantis	1996	Resupply & U.S. crew exchange.
81	Atlantis	1997	Resupply & U.S. crew exchange.
84	Atlantis	1997	Resupply & U.S. crew exchange. GPS & laser test for ESA ATV.
86	Atlantis	1997	Resupply & U.S. crew exchange. GPS test for ESA ATV. First ORBT flight.
89	Endeavour	1998	Resupply & U.S. crew exchange.
91	Discovery	1998	Resupply & U.S. crew return.

ATV = Automated Transfer Vehicle, ESA = European Space Agency, GPS = Global Positioning System
 ORBT = Optimized R-Bar Targeted Rendezvous

Table 7 ISS Assembly and Replenishment Missions

Flight	Orbiter	Year	Comments
88 (2A)	Endeavour	1998	Captured Zarya with RMS, attached Unity Node with PMA 1 & 2.
96 (2A.1)	Discovery	1999	First docking with ISS. ISS resupply and outfitting.
101 (2A.2a)	Atlantis	2000	ISS resupply and outfitting.
106 (2A.2b)	Atlantis	2000	ISS resupply and outfitting.
92 (3A)	Discovery	2000	Radar failure. Z1 Truss, PMA 3, Ku comm & CMGs installed.
97 (4A)	Endeavour	2000	Delivered P6 truss (with solar arrays & radiators).
98 (5A)	Atlantis	2001	Delivered Destiny lab.
102 (5A.1)	Discovery	2001	Tail forward approach. MPLM resupply. Crew exchange.
100 (6A)	Endeavour	2001	Tail forward approach. Installed robotic arm. MPLM resupply.
104 (7A)	Atlantis	2001	Delivered Quest Airlock (installed with ISS robotic arm).
105 (7A.1)	Discovery	2001	MPLM resupply. Crew exchange.
108 (UF-1)	Endeavour	2001	MPLM resupply. Crew exchange.
110 (8A)	Atlantis	2002	Delivered S0 truss and Mobile Transporter.
111 (UF-2)	Endeavour	2002	MPLM resupply. Mobile base installation. Crew exchange.
112 (9A)	Atlantis	2002	Delivered S1 truss, radiators & CETA cart A.
113 (11A)	Endeavour	2002	Delivered P1 truss, radiators & CETA cart B. Crew exchange.
114 (LF-1)	Discovery	2005	MPLM resupply. CMG replacement. First RPM.

A = Assembly, CMG = Control Moment Gyro, CETA = Crew and Equipment Translation Aid,
 MPLM = Multi-Purpose Logistics Module, LF = Logistics Flight, PMA = Pressurized Mating Adapter,
 RPM = R Bar Pitch Maneuver, UF = Utilization Flight

New Sensor Development and New Challenges

In 1987, studies of Shuttle docking with Space Station Freedom indicated that a better proximity operations sensor than the Ku Band radar was needed. Development of new proximity operations sensors encountered difficulty due to budget concerns, and the success of Shuttle rendezvous and proximity operations to date.

The first flight of Hand Held Lidar (HHL) on STS-49 (1992) and the first successful flight of the Trajectory Control Sensor (TCS) lidar on STS-64 (1994) provided the precise range and range rate measurements needed to meet future Mir and ISS docking conditions.⁴³ Though raw data was adequate to meet docking requirements, HHL, TCS, and legacy sensor data (radar, closed circuit television) were processed in a laptop computer using a software package known as the Rendezvous and Proximity Operations Program (RPOP). RPOP provided a relative motion display and proximity operations piloting cues not available in the legacy Shuttle avionics system.⁴³⁻⁴⁵

The operational envelope of proximity operations sensors is illustrated in Fig. 20 for a typical mission to the ISS. In the event

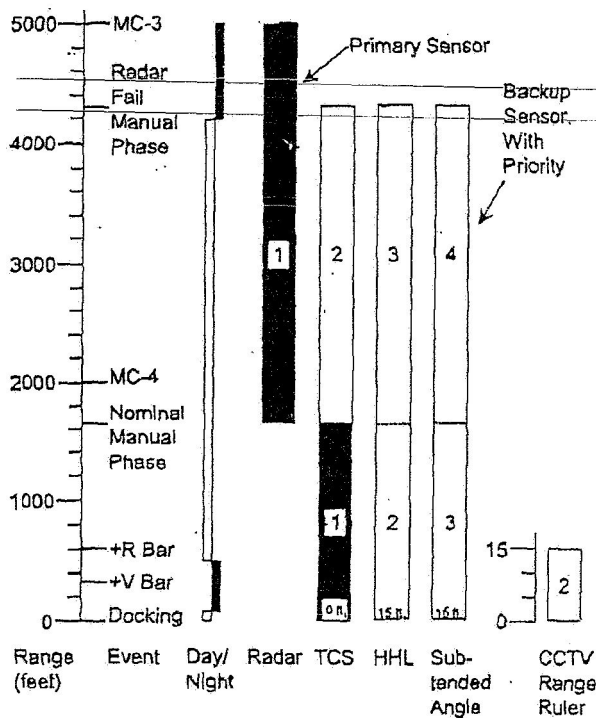

Fig. 20 Operational use of Shuttle proximity operations sensors for a typical ISS mission.

of a radar failure (such as on STS-92), TCS, HHL, and COAS subtended angle are used earlier in the profile than on a nominal mission. A ranging ruler overlay on an aft cockpit Closed Circuit Television (CCTV) monitor provides ranging during the last 15 feet.

While the rendezvous radar is usable with small targets down to ranges of between 80 to 100 feet, the size of Mir and the ISS resulted in beam wandering, which degraded measurement quality. For ISS missions rendezvous radar is generally not used at ranges less than 1000 feet, and after this point the Ku band antenna is used instead for video transmission over the TDRS satellites. TCS and HHL exhibited better performance during proximity operations than the Ku radar. The availability of TCS and HHL measurements was essential to ensure safe and successful approaches to Mir and the ISS.

It was also recognized that Mir and ISS brightness and size issues could complicate or prevent use of daytime star tracker measurements for relative navigation after the Ti maneuver, in the event of a radar failure (Fig. 9). Night star tracker data was obtained between the MC-1 and MC-3 burns during the STS-64 rendezvous with SPARTAN. Analysis techniques verified with the collected flight data were applied to data collected during the STS-63, -71 and 74 missions to Mir. Analysis of these missions indicated that the 18 lights of varying intensity and character (flashing and non-flashing) distributed across Mir provided a suitable target for the Shuttle star tracker. Post Ti contingency night star tracker navigation procedures were first flown on STS-79. A tracking light was added to the ISS Zvezda ("Star") Service Module to enable contingency star tracking during orbital night for ISS missions. Night star tracker navigation was performed during STS-92 due to the radar failure.

Although Shuttle orbiters are equipped with GPS receivers for use on-orbit and during entry, and the ISS is equipped with GPS as well, GPS is not used for Shuttle rendezvous or proximity operations with the ISS.^{46,47}

Flight Control and Plume Challenges

All missions to Mir and ISS required extensive flight control and plume impingement analysis of the various configurations during approach, mated flight, assembly, and separation.⁴⁸⁻⁵² For example STS-88, the first ISS assembly flight, involved the attachment of the U.S. built Unity node to the previously launched, Russian manufactured Zarya module. Unity was docked to the ODS using the RMS before the rendezvous with Zarya. Shuttle flight control analysis was required to ensure that execution of rendezvous maneuvers would not violate structural loading constraints on Unity and the ODS. Zarya was later grappled with the RMS, and docked to Unity. At 42,000 pounds, Zarya was the largest object ever manipulated with the RMS. Analysis was also performed to ensure that ISS orbit raising with Shuttle RCS jets could be successfully performed.⁵¹

New Profile Development

The stable orbit rendezvous profile was designed for mainly inertial and +V Bar approaches (a transition to the -R Bar could be performed upon arrival at the +V Bar). A difficulty with the stable orbit approach was the increased amount of propellant required for braking in Low Z mode (Fig. 8) and greater sensitivity to plume impingement loads of Mir and ISS. Reducing plume concerns (static, dynamic, thermal, contamination) was critical, particularly for solar arrays.

Planning for Mir and ISS rendezvous missions prompted renewed study of the +R Bar approach in 1993 (Fig. 7). Use of orbital mechanics to reduce the needed braking, rather than using RCS jet firings, would lower plume impingement and provide propellant savings. An additional benefit was that a +R Bar separation could also take advantage of orbital mechanics, requiring fewer jet firings. Studies indicated that the new approach could be performed without changing on-board computer targeting constants for the stable orbit profile. The availability of laser sensors (TCS, HHL) provided range and range rate measurement redundancy which was not available when the +R Bar approach was considered for the Skylab reboost mission in the late 1970s. After extensive analysis, procedure development, and efforts to overcome programmatic resistance, the +R Bar approach was approved in April of 1994, and first flown on STS-66 in November of that year. +R Bar approaches were flown on all missions to Mir.^{44,53} The Mir missions (Fig. 21) validated Shuttle proximity operations and docking analysis originally performed for Space Station Freedom.

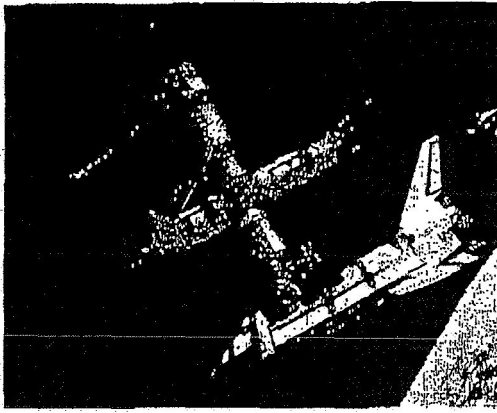

Fig. 21 Atlantis docked to Mir during STS-71, as seen from Soyuz TM-21.

Further analysis led rendezvous designers to investigate changes to the rendezvous profile itself, before the proximity operations phase, to further reduce propellant consumption and increase Shuttle payload capability. The stable orbit profile, like its' predecessor the coelliptic profile, was a "high energy" profile designed to support a terminal phase inertial approach and direct intercept. Additional propellant and procedures were required for R-Bar or V-Bar activities. A new profile was designed which was optimized for the +R Bar approach.

Optimized R-Bar Targeted Rendezvous (ORBT) differed from stable orbit in several ways (Fig. 22). ORBT was designed to optimally set up initial conditions for a low energy coast up the

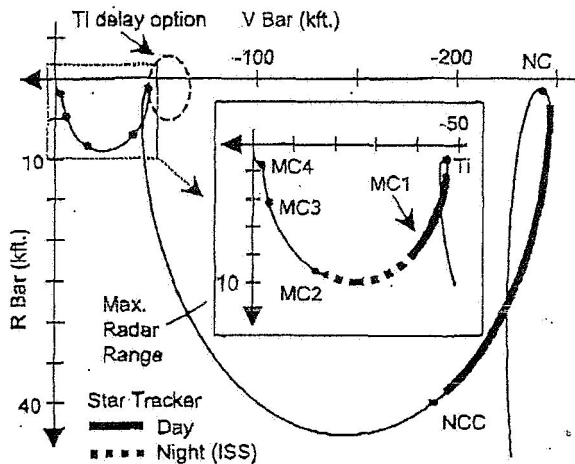

Fig. 22 Optimized R-Bar Targeted Rendezvous (1997-).

+R Bar (Fig. 23, 24). By targeting the TI, and first three mid-course maneuvers for the manual takeover point at 2,000 feet, rather than for intercept, manual phase trajectory dispersions were reduced and propellant consumption was cut. The TI point for ORBT was below the V Bar so that the subsequent MC-4 ΔV vector would be primarily in the +X body axis direction (Fig. 8), saving propellant. The MC-4 maneuver targeted the orbiter for a point 600 feet below the target, on the +R Bar. ORBT did not require as many +R Bar stabilization burns or as many braking burns as were needed with the stable orbit profile. The first ORBT flight was STS-86 to Mir (September-October 1997).

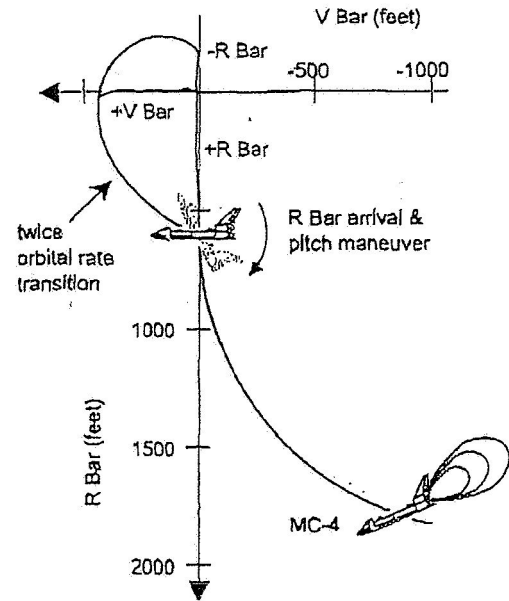

Fig. 23 Approaches to ISS.

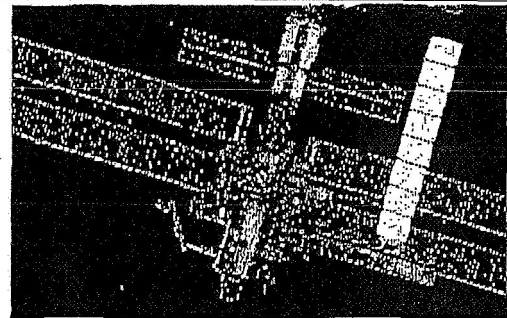

Fig. 24 ISS viewed from Endeavour on the +R Bar during STS-113.

Proximity Operations and Docking

Final approach to the Mir (+R Bar) and ISS (+V Bar, +R Bar, or -R Bar, depending on the ISS configuration, Fig. 23) involved flying a precise range and range rate profile. An 8-degree, followed by a 5-degree, approach corridor centered on the Mir or ISS docking hatch target was flown (Fig. 25). Angular fly-outs were performed to achieve the required alignment for docking. Station-keeping points existed during the approach to allow delays to ensure proper lighting, gain time to work systems issues or obtain visibility to ground communication stations, if required.



Fig. 25 Entering ISS approach corridor at ~ 400 feet.

Post-undocking fly-arounds were used to obtain photography of the Mir and ISS, if sufficient propellant was available.

After the loss of Columbia, a +R Bar Pitch Maneuver at ~600 feet was added to the ISS approach (Fig. 23). The maneuver permits photography of the Shuttle thermal protection surfaces by the ISS

crew.^{45,54} A new requirement to perform Shuttle thermal protection repair at the ISS also drove extensive proximity operations analysis and procedure development. The Shuttle RMS grapples a fixture on the ISS and the Shuttle is rotated to an appropriate position relative to the ISS for repair. An ISS attitude was defined that would facilitate a safe separation (no undesirable contact with or plumbing of ISS and Soyuz structure) and re-docking in the event a RMS or other failure resulted in a contingency separation from the ISS.⁵⁵

Launch Windows and Mission Planning

Mission planning for ISS assembly and replenishment missions is a complex process, with many factors such as ISS logistics, ISS hardware maintenance, ISS orbit maintenance, Shuttle ascent abort, rendezvous and proximity operations considerations, and visits of other vehicles (Soyuz, Progress, ATV, HTV) to the ISS that must be considered.^{56,57}

After the loss of *Columbia*, a requirement to perform photography of the Shuttle during ascent (using ground based cameras and cameras mounted on NASA WB-57F aircraft flying at ~60,000 feet) and External Tank (ET) photography after separation led to daylight launch and acceptable ET photography requirements. Only the ISS planar launch windows which met these lighting conditions were acceptable. This severely restricted launch dates available for ISS missions, creating launch seasons.⁵⁸

In coordination with the Russians, contingency plans exist for the ISS to lower its orbit in the event Shuttle ascent propulsion problems (such as an early main engine shutdown) limit the ability of the Shuttle to fly the planned rendezvous profile.^{58,59}

X. Conclusions

Shuttle rendezvous and proximity operations technique development has been able to respond to new program requirements, but the development process was not always straightforward. The success of the Space Shuttle in fulfilling new, challenging and unforeseen requirements has been due to extensive analysis conducted by integrated, interdisciplinary teams; and continuous development of new nominal and contingency procedures for a vehicle and ground support system that possesses a high degree of flexibility. However, the success of Shuttle rendezvous and proximity operations has come at the expense of some of the original objectives and goals of the Shuttle Program. These included simplified and standardized mission planning and training, lower number of mission support personnel, high flight rates, elimination of extensive flight-to-flight analysis, no computation of flight specific trajectory data, and no generation of customized onboard charts for each mission. Successful adaptation of proven rendezvous principles to meet new and emerging operational and programmatic constraints was in part due to the carry-over of experienced personnel from the shorter duration Gemini and Apollo programs. These personnel possessed extensive experience in the development and analysis of vehicle and subsystem performance specifications, requirements and operations concepts.

Appendix - Relative Frame

Relative motion is often depicted in a Local Vertical Local Horizontal (LVLH) or Local Vertical Curvilinear (LVC) frame (Fig. 26).⁶⁰

The target position and velocity vectors are used to define the axes. Nomenclature for the axes follows the convention used within the Shuttle Program.

The +Z axis, also call the +R Bar axis, is defined as:

$$\hat{i}_z = -\text{unit}(r_T)$$

The +Y axis, also called the -H Bar axis, is defined as:

$$\hat{i}_y = -\text{unit}(r_T \times v_T)$$

The +X axis, also called the +V Bar axis, is defined as:

$$\hat{i}_x = \text{unit}[(r_T \times v_T) \times r_T]$$

In the LVC frame, the V Bar is curvilinear, rather than rectilinear.

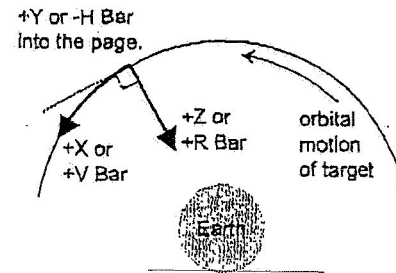

Fig. 26 Local Vertical Curvilinear reference frame.

Acknowledgments

The works of authors whose material could not be referenced here is acknowledged. These authors include Jerome A. Bell, Brian Bertrand, John T. Cox, David P. Dannemiller, Richard E. Kincade, Edgar C. Lineberry, John P. McIntire, Duane K. Mosel, James E. Oberg, Don J. Pearson, Charles R. Price, Mark B. Schrock, Philip Shannahan, and William R. Summa.

References

- ¹Goodman, J. L., "Knowledge Capture and Management - Key to Ensuring Flight Safety and Mission Success," *AIAA Space 2005 Conference*, AIAA, Reston, VA, 2005.
- ²Houbolt, J. C., "Problems And Potentialities Of Space Rendezvous," *Astronautica ACTA VII*, 1961, pp. 406-429.
- ³Voageley, A. W., and Brissenden, R. F., "Survey of Rendezvous Progress," *Proceedings of the AIAA Guidance and Control Conference, Guidance and Control II*, Academic Press, New York, NY, 1964.
- ⁴Peanington, J. E., and Brissenden, R. F., "Visual Capability in Rendezvous," *Astronautics and Aerospace Engineering*, AIAA, Volume 1, Number 1, Feb. 1963, pp. 96-99.
- ⁵Houbolt, J. C., "Lunar Rendezvous," *International Science and Technology*, Feb. 1963, pp. 62-70.
- ⁶Hansen, J. R., *Enchanted Rendezvous*, NASA Monographs in Aerospace History Series #4, NASA, Washington, D. C., 1995.
- ⁷McDivitt, J. A., "Rendezvous, Rescue And Recovery Aspects Of Space Operations," *Proceedings of the Symposium on Space Rendezvous, Rescue and Recovery, Advances In The Astronautical Sciences*, Vol. 16; Part 2, Univelt, San Diego, CA, 1964, pp. 12-19.
- ⁸Chamberlin, J. A., and Rose, J. T., "Gemini Rendezvous Program," *Journal of Spacecraft and Rockets*, Vol. 1, No. 1, Jan. 1964, pp. 13-18.
- ⁹*Gemini Midprogram Conference*, NASA SP-121, NASA, Washington, D.C., 1966.
- ¹⁰*Gemini Summary Conference*, NASA SP-138, NASA, Washington, D.C., 1967.
- ¹¹Houbolt, J. C., "An Assessment of Rendezvous Accomplishments," *Applied Mechanics Reviews*, Vol. 20, No. 1, Jan. 1967.

- ¹²Lunney, G. S., "Summary of Gemini Rendezvous Experience," *AIAA Flight Test, Simulation and Support Conference*, AIAA, Reston, VA, 1967.
- ¹³Parren, R. P., and Meyer, J. P., "Development Of The Gemini Operational Rendezvous Plan," *AIAA Journal of Spacecraft And Rockets*, Vol. 5, No. 9, Sept. 1968, pp. 1023-1028.
- ¹⁴Hacker, B. C., and Grimwood, J. M., *On The Shoulders Of Titans*, NASA SP-4203, NASA, Washington, D.C., 1977.
- ¹⁵Harland, D., *How NASA Learned To Fly In Space*, Collector's Guide Publishing Inc., Burlington, Ontario, Canada, 2004.
- ¹⁶Aldrin, E. E., "Line-Of-Sight Guidance Techniques For Manned Orbital Rendezvous," PhD Dissertation, Massachusetts Institute of Technology, Cambridge, MA, Jan. 1963.
- ¹⁷Young, K. A., and Alexander, J. D., "Apollo Lunar Rendezvous," *AIAA Journal of Spacecraft And Rockets*, Vol. 7, No. 9, Sept. 1970, pp. 1083-1086.
- ¹⁸Conrad, C., and Kerwin, J. P., "Skylab 1 and 2 - Pilot's Report," *Proceedings of the 17th Symposium of the Society of Experimental Test Pilots*, Society of Experimental Test Pilots, Lancaster, CA, 1973, pp. 211-218.
- ¹⁹Bean, A. L., and Evans, R. E., "Apollo-Soyuz Joint Mission Results," *Proceedings of the 19th Symposium of the Society of Experimental Test Pilots*, Lancaster, CA, 1975, pp. 173-178.
- ²⁰Ezell, E. C., and Ezell, L. N., *The Partnership: A History of the Apollo-Soyuz Test Project*, NASA SP-4209, NASA, Washington, DC, 1978.
- ²¹Pearson, D. J., "Shuttle Rendezvous and Proximity Operations," *Proceedings of the CNES International Symposium on Space Dynamics*, Centre National d'Etudes Spatiales, Paris, France, 1989, pp. 833-851.
- ²²Young, K. A., "Representative Space Shuttle Missions and Their Impact on Shuttle Design," *AIAA/ASME/SAE Joint Space Mission Planning and Execution Meeting*, AIAA, Reston, VA, 1973.
- ²³Nakano, M. M., and Williams, R. L., "Space Shuttle On-Orbit Flight Control System," *Proceedings of the AIAA Guidance and Control Conference*, AIAA, Reston, VA, 1982.
- ²⁴McQuillan, W. F., et al., "Rendezvous Radar For Space Shuttle Orbiter," *Proceedings of the International Telemetering Conference*, International Foundation for Telemetering, 1974, pp. 447-465.
- ²⁵Smith, F. E., Campbell, M. E., Blucker, T. J., Manry, C. E., and Saulicic, I., "Shuttle Orbiter Stellar-Inertial Reference System," *AIAA Journal of Guidance And Control*, Vol. 6, No. 6, 1983, pp. 424-431.
- ²⁶Wylie, A. D., and deVein, H. G., "Onboard Rendezvous Navigation For The Space Shuttle," *Navigation: Journal of the Institute of Navigation*, Vol. 32, No. 3, Fall 1985, pp. 197-220.
- ²⁷Kachmar, P., "Apollo and Space Shuttle On-Board Navigation Systems: Application of Kalman Filtering Techniques," *58th Annual Meeting of the Institute of Navigation and CIGTF Guidance Test Symposium*, Institute of Navigation, Fairfax, VA, 2002.
- ²⁸Muller, E. S., and Kachmar, P. M., "A New Approach To On-Board Navigation," *Navigation: Journal of the Institute of Navigation*, Vol. 18, No. 4, Winter 1971-1972, pp. 369-385.
- ²⁹Goodman, I. L., "Space Shuttle Navigation in the GPS Era," *Proceedings of the Institute of Navigation National Technical Meeting*, Institute of Navigation, Fairfax, VA, 2001.
- ³⁰Collins, D. J., "Flight Operations For Shuttle Rendezvous Navigation and Targeting," *Proceedings of the IEEE PLANS '84 - Position Location and Navigation Symposium*, IEEE, New York, NY, 1984, pp. 106-112.
- ³¹Pearson, D. J., "The Glideslope Approach," *Orbital Mechanics and Mission Design - Advances in the Astronautical Sciences*, Vol. 69, Univelt, San Diego, CA, 1989.
- ³²Alexander, R. N., and Chiu, P. B., "Space Shuttle On-Orbit Proximity Operations," *Proceedings of the 20th Aerospace Sciences Meeting*, AIAA, Reston, VA, 1982.
- ³³Crippen, R. L., and Hauck, F. H., "Orbiter Operations In Close Proximity To Free-Flying Satellites Or Formation Flying In Space," *Proceedings of the 27th Symposium of the Society of Experimental Test Pilots*, Society of Experimental Test Pilots, Lancaster, CA, 1983, pp. 314-334.
- ³⁴Oberg, J. E., "Control Of RCS Plume Effects During Proximity Operations On STS Missions," *Proceedings of the AIAA Shuttle Environment And Operations Meeting*, AIAA, Reston, VA, 1983, pp. 68-71.
- ³⁵Jenkins, D. R., *Space Shuttle - The History of the National Space Transportation System - The First 100 Missions*, Specialty Press Publishers, North Branch, MN, 2001.
- ³⁶Gavin, R. T., "Development Of A Cooperative Operational Rendezvous Plan For Europa And Other Maneuvering Shuttle Payloads," *Proceedings of the 38th Congress of the International Astronautical Federation*, International Astronautical Federation, Paris, France, 1987.
- ³⁷Lee, S., et al., "Hubble Space Telescope Servicing Mission 3A Rendezvous Operations," *Guidance and Control 2001, Advances in the Astronautical Sciences*, Vol. 107, Univelt, San Diego, CA, 2001, pp. 615-633.
- ³⁸Carson, D. E., "SPARTAN Project Overview," *Proceedings of the First Annual NRO-OSL/CSFC-ATS Rideshare Conference*, National Reconnaissance Office, Chantilly, VA, 1999.
- ³⁹Wattenbach, R., and Moritz, K., "Astronomical Shuttle Pallet Satellite (ASTRO-SPAS)," *Acta Astronautica*, Vol. 40, No. 10, May, 1997, pp. 723-732.
- ⁴⁰Hauck, F. H., and Gardner, D. A., "Space Salvage - A Report On Shuttle Mission STS 51-A," *Proceedings of the 29th Symposium of the Society of Experimental Test Pilots*, Society of Experimental Test Pilots, Lancaster, CA, 1985, pp. 236-261.
- ⁴¹Dreger, F., et al., "Euroca: The Flight Dynamics of the Retrieval," *ESA Bulletin*, No. 76, Nov. 1993, pp. 92-99.
- ⁴²Sampaio, C. E., "A Lighting and Visibility Evaluation of the Shuttle/Mir Docking Target," *Proceedings of the 39th Human Factors and Ergonomics Society Annual Meeting*, Human Factors and Ergonomics Society, Santa Monica, CA, 1995, pp. 45-49.
- ⁴³Clark, F., Spehar, P., Hinkel, H., and Brazzel, J., "Laser-Based Relative Navigation and Guidance for Space Shuttle Proximity Operations," *Guidance and Control 2003, Advances in the Astronautical Sciences*, Vol. 113, Univelt, San Diego, CA, 2003.
- ⁴⁴Zimpfer, D., and Spehar, P., "STS-71 Shuttle/Mir GNC Mission Overview," *Spaceflight Mechanics 1996, Advances In The Astronautical Sciences*, Vol. 93, Part I, Univelt, San Diego, CA, 1996, pp. 441-460.
- ⁴⁵Brazzel, J., Clark, F., and Spehar, P., "RPOP Enhancements to Support the Space Shuttle R-Bar Pitch Maneuver for Tilt Inspection," *AIAA Guidance, Navigation, and Control Conference*, AIAA, Reston, VA, 2005.
- ⁴⁶Goodman, J. L., "Application of GPS Navigation to Space Flight," *2005 IEEE Aerospace Conference*, IEEE, New York, NY, 2005.
- ⁴⁷Goodman, J. L., "A GPS Receiver Upgrade For The Space Shuttle - Rationale And Considerations," *40th AIAA/ASME/SAE/ASEE Joint Propulsion Conference and Exhibit*, AIAA, Reston, VA, 2004.
- ⁴⁸Dagen, J. D., "Structural Integration of the Space Shuttle and the Mir Space Station," *Spaceflight Mechanics 1996, Advances in the Astronautical Sciences*, Vol. 93, Part I, Univelt, San Diego, CA, 1996, pp. 461-471.
- ⁴⁹Jackson, M., Zimpfer, D., and Lepanto, J., "Identification of Shuttle/Mir Structural Dynamics For Notch Filter Tuning," *Spaceflight Mechanics 1996, Advances in the Astronautical Sciences*, Vol. 93, Part I, Univelt, San Diego, CA, 1996, pp. 493-509.
- ⁵⁰Zimpfer, D., et al., "Shuttle Stability and Control for the STS-71 Shuttle/Mir Mated Configuration," *Spaceflight Mechanics 1996, Advances in the Astronautical Sciences*, Vol. 93, Part I, Univelt, San Diego, CA, 1996, pp. 473-492.
- ⁵¹Hall, R., et al., "Flight Control Overview Of STS-88, The First Space Station Assembly Flight," *Aerodynamics 1999, Advances in the Astronautical Sciences*, Vol. 103, Part II, Univelt, San Diego, CA, 1999, pp. 1063-1081.
- ⁵²Rochelle, W. C., Reid, E. A., Carl, T. L., Smith, R. N., and Lumpkin III, F. E., "Thermal Analysis For Orbiter And ISS Plume Impingement On International Space Station," *35th AIAA Thermophysics Conference*, AIAA, Reston, VA, 2001.
- ⁵³Gibson, R. L., and Precourt, C. J., "The First Space Shuttle to Mir Docking Mission," *Proceedings of the 39th Symposium of the Society of Experimental Test Pilots*, Society of Experimental Test Pilots, Lancaster, CA, 1995, pp. 386-419.
- ⁵⁴Walker, S., LoPresti, J., Schrock, M., and Hall, R., "Space Shuttle Rbar Pitch Maneuver For Thermal Protection System Inspection Overview," *AIAA Guidance, Navigation, and Control Conference*, AIAA, Reston, VA, 2005.
- ⁵⁵Matchula, M., "Orbiter Repair Maneuver Contingency Separation Methods and Analysis," *AIAA Guidance, Navigation, and Control Conference*, AIAA, Reston, VA, 2005.
- ⁵⁶Hale, N. W., and Conte, B. A., "Considerations in Rendezvous Launch Window Management," *53rd International Astronautical Congress*, International Astronautical Federation, Paris, France, 2002.
- ⁵⁷Jones, R., "Architecture In Mission Integration, Choreographing Constraints," *30th International Conference on Environmental Systems*, Society of Automotive Engineers, Warrendale, PA, 2000.
- ⁵⁸Adamo, D. R., "ISS Rendezvous Phasing Considerations Pertaining to Optimal STS-114/LF1 Launch Opportunities," *AIAA Guidance, Navigation, and Control Conference*, AIAA, Reston, VA, 2005.

³⁹Adamo, D. R., "Contingency ISS Rendezvous Recovery Planning By Houston And Moscow Control Centers," *Astrodynamics 1999, Advances in the Astronautical Sciences*, Vol. 103, Part III, Univelt, San Diego, CA, 1999.

⁴⁰Adamo, D. R., "A Meaningful Relative Motion Coordinate System For Generic Use," *2005 AAS/ALAA Astrodynamics Specialist Conference, Advances in the Astronautical Sciences*, Univelt, San Diego, CA, 2005.