

NASA/CR—2006–213488

U.S. Army RDECOM No. AFDD/TR-06-003

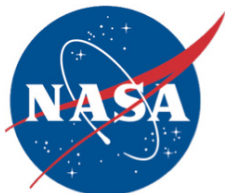

Development of Handling Qualities Criteria for Rotorcraft with Externally Slung Loads

*Roger H. Hoh, Robert K. Heffley, and David G. Mitchell
Hoh Aeronautics, Inc., Lomita, California
Ames Research Center, Moffett Field, California*

Prepared for
Ames Research Center
for Contract NAS2-14360

NASA STI Program ... in Profile

Since its founding, NASA has been dedicated to the advancement of aeronautics and space science. The NASA scientific and technical information (STI) program plays a key part in helping NASA maintain this important role.

The NASA STI program operates under the auspices of the Agency Chief Information Officer. It collects, organizes, provides for archiving, and disseminates NASA's STI. The NASA STI program provides access to the NASA Aeronautics and Space Database and its public interface, the NASA Technical Report Server, thus providing one of the largest collections of aeronautical and space science STI in the world. Results are published in both non-NASA channels and by NASA in the NASA STI Report Series, which includes the following report types:

- **TECHNICAL PUBLICATION.** Reports of completed research or a major significant phase of research that present the results of NASA Programs and include extensive data or theoretical analysis. Includes compilations of significant scientific and technical data and information deemed to be of continuing reference value. NASA counterpart of peer-reviewed formal professional papers but has less stringent limitations on manuscript length and extent of graphic presentations.
- **TECHNICAL MEMORANDUM.** Scientific and technical findings that are preliminary or of specialized interest, e.g., quick release reports, working papers, and bibliographies that contain minimal annotation. Does not contain extensive analysis.
- **CONTRACTOR REPORT.** Scientific and technical findings by NASA-sponsored contractors and grantees.

- **CONFERENCE PUBLICATION.** Collected papers from scientific and technical conferences, symposia, seminars, or other meetings sponsored or co-sponsored by NASA.
- **SPECIAL PUBLICATION.** Scientific, technical, or historical information from NASA programs, projects, and missions, often concerned with subjects having substantial public interest.
- **TECHNICAL TRANSLATION.** English-language translations of foreign scientific and technical material pertinent to NASA's mission.

Specialized services also include creating custom thesauri, building customized databases, and organizing and publishing research results.

For more information about the NASA STI program, see the following:

- Access the NASA STI program home page at <http://www.sti.nasa.gov>
- E-mail your question via the Internet to help@sti.nasa.gov
- Fax your question to the NASA STI Help Desk at (301) 621-0134
- Phone the NASA STI Help Desk at (301) 621-0390
- Write to:
NASA STI Help Desk
NASA Center for AeroSpace Information
7121 Standard Drive
Hanover, MD 21076-1320

NASA/CR—2006–213488
U.S. Army RDECOM No. AFDD/TR-06-003

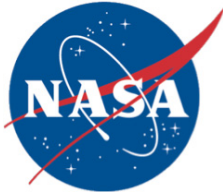

Development of Handling Qualities Criteria for Rotorcraft with Externally Slung Loads

*Roger H. Hoh, Robert K. Heffley, and David G. Mitchell
Hoh Aeronautics, Inc., Lomita, California
Ames Research Center, Moffett Field, California*

Prepared for
Ames Research Center
for Contract NAS2-14360

National Aeronautics and
Space Administration

*Ames Research Center
Moffett Field, CA 94035-1000*

October 2006

Available from:

NASA Center for AeroSpace Information
7121 Standard Drive
Hanover, MD 21076-1320
(301) 621-0390

National Technical Information Service
5285 Port Royal Road
Springfield, VA 22161
(703) 487-4650

CONTENTS

1	Introduction.....	1
1.1	Technical Approach.....	2
1.2	Organization of Report	3
2	Development of External-Load Criteria	3
2.1	Overview of Simulation.....	3
2.2	Proposed Criteria for ADS-33E Handling Qualities Specification – Helicopters with External Load.....	4
2.2.1	Quantitative Criteria – Helicopters with External Load	4
2.2.2	Flight-Test Maneuvers – Helicopters with External Load.....	5
2.2.3	Quantitative Criteria – Cargo Helicopters with Internal Load.....	6
2.3	Development of Criteria for External Load.....	6
3	Supporting Data	17
3.1	Tested Configurations.....	17
3.2	Correlation with Bandwidth and Load-Coupling Parameters.....	17
3.3	Effect of Load-Mass Ratio.....	21
3.4	Effect of Sling Length.....	24
3.5	Effect of Hook-to-C.G. Distance, l_{hook}	25
3.6	Effect of Higher-Order Flight Control System and Attitude Bandwidth.....	27
3.7	Effect of Roll Inertia	30
3.8	Comparison of Longitudinal and Lateral Criteria Boundaries	30
4	Results With Load Off.....	31
4.1	Pitch and Roll Bandwidth.....	31
4.2	Heading Bandwidth	33
5	Summary and Conclusions	33
6	References.....	34
	Appendix A – Detailed Test Configurations	36
A.1	Simulated Helicopter	36
A.2	Internal and External Loadings.....	36
A.3	Flight Control System.....	36
A.4	Test Matrix.....	38
	Appendix B – Detailed Pilot Ratings and Commentary	40
B.1	Cooper-Harper Handling-Qualities Results.....	40
B.2	Pilot Commentary	53
	Appendix C – Description of Simulation and Tasks	85
C.1	Math Models.....	85
C.1.1	RotorGen Model	86
C.1.2	Cicolani Single-Point Suspension Model	87
C.1.3	Linear Analysis Model.....	87
C.2	Vertical Motion Simulator (VMS).....	88
C.3	Task Descriptions.....	89
	Appendix D – Bode and Root Loci of Tested Configurations.....	96

D.1	Longitudinal Velocity	96
D.2	Lateral Velocity	123
Appendix E – Attitude-Response Characteristics.....		150
E.1	Effect of Load Mass on Roll-Attitude Response	151
E.2	Effect of Hook-to-C.G. Distance	153
E.3	Effect of Sling Length.....	156

FIGURES

Figure 1. CH-47D with a Single-Point External Load.....	1
Figure 2. Closed-Loop Piloted Control in Hover – Helicopter Augmented to ACAH.....	7
Figure 3. Bode and Root Locus for Load Off (Configuration 100).....	9
Figure 4. Bode and Root Locus with Load On (Configuration 110).....	10
Figure 5. Definition of $\omega_{BW_{\phi_1}}$ and $\Delta\omega_L$	13
Figure 6. Definition of $\omega_{BW_{\phi_2}}$	14
Figure 7. Definition of $\omega_{BW_{G_1}}$	15
Figure 8. Definition of $\omega_{BW_{G_2}}$	16
Figure 9. Correlation of Cooper-Harper Pilot Rating Data for Longitudinal Axis.....	18
Figure 10. Correlation of Cooper-Harper Pilot Rating Data for Lateral Axis.....	19
Figure 11. Effect of Load-Mass Ratio.....	22
Figure 12. Effect of Load-Mass Ratio on HQR.....	23
Figure 13. Effect of Sling Length.....	24
Figure 14. Effect of Hook-to-C.G. Distance.....	26
Figure 15. Effect of Lag Lead in Flight Control System.....	28
Figure 16. Effect of Roll Inertia.....	30
Figure 17. Pilot Ratings with Load Off – Precision Hover Task.....	31
Figure 18. Effect of Bandwidth on Various Tasks.....	32
Figure 19. Effect of Bandwidth on Hovering Turn Task – Load Off.....	33
Figure A-1. Pitch and Roll SCAS Configuration.....	37
Figure C-1. Load Geometry (Single-Point Suspension, Roll Axis).....	85
Figure C-2. NASA-Ames Verticle Motion Simulator VMS).....	88
Figure C-3. Simulator Instrument Panel.....	89
Figure C-4. Hover Maneuver Course Layout for the VMS Simulation.....	91
Figure C-5. Normal Departure/Abort-to-Landing Zone Course for VMS Simulation.....	93
Figure C-6. Lateral-Reposition Maneuver Course for VMS Simulation.....	94
Figure C-7. Hover-Turn Maneuver Course for VMS Simulation.....	95
Figure D-1. Longitudinal Translational-Rate-Loop-Closure Characteristics – Configuration 100 – Load Off.....	96
Figure D-2. Longitudinal Translational-Rate-Loop-Closure Characteristics – Configuration 200 – Load Off.....	97

Figure D-3. Longitudinal Translational-Rate-Loop-Closure Characteristics – Configuration 110.	98
Figure D-4. Longitudinal Translational-Rate-Loop-Closure Characteristics – Configuration 120.	99
Figure D-5. Longitudinal Translational-Rate-Loop-Closure Characteristics – Configuration 130.	100
Figure D-6. Longitudinal Translational-Rate-Loop-Closure Characteristics – Configuration 140.	101
Figure D-7. Longitudinal Translational-Rate-Loop-Closure Characteristics – Configuration 150.	102
Figure D-8. Longitudinal Translational-Rate-Loop-Closure Characteristics – Configuration 155.	103
Figure D-9. Longitudinal Translational-Rate-Loop-Closure Characteristics – Configuration 156.	104
Figure D-10. Longitudinal Translational-Rate-Loop-Closure Characteristics – Configuration 160.	105
Figure D-11. Longitudinal Translational-Rate-Loop-Closure Characteristics – Configuration 165.	106
Figure D-12. Longitudinal Translational-Rate-Loop-Closure Characteristics – Configuration 166.	107
Figure D-13. Longitudinal Translational-Rate-Loop-Closure Characteristics – Configuration 189.	108
Figure D-14. Longitudinal Translational-Rate-Loop-Closure Characteristics – Configuration 191.	109
Figure D-15. Longitudinal Translational-Rate-Loop-Closure Characteristics – Configuration 192.	110
Figure D-16. Longitudinal Translational-Rate-Loop-Closure Characteristics – Configuration 195.	111
Figure D-17. Longitudinal Translational-Rate-Loop-Closure Characteristics – Configuration 210.	112
Figure D-18. Longitudinal Translational-Rate-Loop-Closure Characteristics – Configuration 214.	113
Figure D-19. Longitudinal Translational-Rate-Loop-Closure Characteristics – Configuration 215.	114
Figure D-20. Longitudinal Translational-Rate-Loop-Closure Characteristics – Configuration 217.	115
Figure D-21. Longitudinal Translational-Rate-Loop-Closure Characteristics – Configuration 220.	116

Figure D-22. Longitudinal Translational-Rate-Loop-Closure Characteristics – Configuration 230.	117
Figure D-23. Longitudinal Translational-Rate-Loop-Closure Characteristics – Configuration 240.	118
Figure D-24. Longitudinal Translational-Rate-Loop-Closure Characteristics – Configuration 290.	119
Figure D-25. Longitudinal Translational-Rate-Loop-Closure Characteristics – Configuration 293.	120
Figure D-26. Longitudinal Translational-Rate-Loop-Closure Characteristics – Configuration 294.	121
Figure D-27. Longitudinal Translational-Rate-Loop-Closure Characteristics – Configuration 295.	122
Figure D-28. Lateral Translational-Rate-Loop-Closure Characteristics – Configuration 100 – No Load.	123
Figure D-29. Lateral Translational-Rate-Loop-Closure Characteristics – Configuration 200 – No Load.	124
Figure D-30. Lateral Translational-Rate-Loop-Closure Characteristics – Configuration 110.	125
Figure D-31. Lateral Translational-Rate-Loop-Closure Characteristics – Configuration 120.	126
Figure D-32. Lateral Translational-Rate-Loop-Closure Characteristics – Configuration 130.	127
Figure D-33. Lateral Translational-Rate-Loop-Closure Characteristics – Configuration 140.	128
Figure D-34. Lateral Translational-Rate-Loop-Closure-Characteristics – Configuration 155.	129
Figure D-35. Lateral Translational-Rate-Loop-Closure Characteristics – Configuration 156.	130
Figure D-36. Lateral Translational-Rate-Loop-Closure Characteristics – Configuration 160.	131
Figure D-37. Lateral Translational-Rate-Loop-Closure Characteristics – Configuration 165.	132
Figure D-38. Lateral Translational-Rate-Loop-Closure Characteristics – Configuration 166.	133
Figure D-39. Lateral Translational-Rate-Loop-Closure Characteristics – Configuration 189.	134
Figure D-40. Lateral Translational-Rate-Loop-Closure Characteristics – Configuration 191.	135

Figure D-41. Lateral Translational-Rate-Loop-Closure Characteristics – Configuration 192.....	136
Figure D-42. Lateral Translational-Rate-Loop-Closure Characteristics – Configuration 193.....	137
Figure D-43. Lateral Translational-Rate-Loop-Closure Characteristics – Configuration 195.....	138
Figure D-44. Lateral Translational-Rate-Loop-Closure Characteristics – Configuration 210.....	139
Figure D-45. Lateral Translational-Rate-Loop-Closure Characteristics – Configuration 214.....	140
Figure D-46. Lateral Translational-Rate-Loop-Closure Characteristics – Configuration 215.....	141
Figure D-47. Lateral Translational-Rate-Loop-Closure Characteristics – Configuration 217.....	142
Figure D-48. Lateral Translational-Rate-Loop-Closure Characteristics – Configuration 220.....	143
Figure D-49. Lateral Translational-Rate-Loop-Closure Characteristics – Configuration 230.....	144
Figure D-50. Lateral Translational-Rate-Loop-Closure Characteristics – Configuration 240.....	145
Figure D-51. Lateral Translational-Rate-Loop-Closure Characteristics – Configuration 290.....	146
Figure D-52. Lateral Translational-Rate-Loop-Closure Characteristics – Configuration 293.....	147
Figure D-53. Lateral Translational-Rate-Loop-Closure Characteristics – Configuration 294.....	148
Figure D-54. Lateral Translational-Rate-Loop-Closure Characteristics – Configuration 295.....	149
Figure E-1. Frequency Response of Bank Angle with Lateral Control for Varying SCAS Bandwidth.....	150
Figure E-2. Frequency Response of Bank Angle with Lateral Control for Varying Load-Mass Ratios.....	151
Figure E-3. Pole-Zero Migration with Variation of Load-Mass Ratio.....	152
Figure E-4. HQRs for Varying Hook-to-C.G. Distance.....	153
Figure E-5. Frequency Response of Bank Angle with Lateral Control for Varying Hook-to-C.G. Offset.....	154
Figure E-6. Pole-Zero Migration for Varying Hook-to-C.G. Offset.....	155
Figure E-7. HQR as a Function of Sling Length.....	156

FigureE-8. Frequency Response of Bank Angle with Lateral Control for Varying Sling Length.....	157
Figure E-9. Pole-Zero Locations as a Function of Sling Length.....	158

TABLES

Table 1 Summary of External-Load Configurations and Pilot Ratings from VMS Piloted Simulation Experiments.....	20
Table 2. Effect of Control System Lag Lead on Attitude Bandwidth and HQR.....	29
Table 3. Comparison of Effects of Control System Lag and Sling Length.....	29
Table A-1 Summary of Test Configurations.....	38
Table B-1. Cooper-Harper HQRs from SL4 Experiment.....	40
Table B-2. Cooper-Harper HQRs from SL5 Experiment - Precision Hover Task.....	49

1 Introduction

The handling-qualities criteria described in this report were derived based on the results of two external load simulations conducted on the NASA Ames Vertical Motion Simulator (VMS): Slung Load 4 and Slung Load 5 (SL4 and SL5). These were the last of a series of five manned simulations intended to explore handling-qualities issues for large cargo helicopters, particularly where carriage of slung external loads are involved. The type of aircraft is represented in figure 1 by the CH-47D with an external load.

The first three VMS experiments identified crucial flight tasks, defined test maneuvers, developed and refined simulator math models, and targeted the system dynamics that needed special study. These activities have culminated in the fourth and fifth simulator experiments: SL4 and SL5, respectively.



Figure 1. CH-47D with a Single-Point External Load.

The motivation for this work stemmed from a need to include handling qualities criteria for cargo helicopters in an upgrade in the U.S. Army rotorcraft handling-qualities specification, ADS-33D (ref. 1) to ADS-33E (ref. 2). Handling qualities with external load were of special interest because there were essentially no existing data upon which to base a criterion at the outset of this program. In addition, it was necessary to develop applicable demonstration flight maneuvers for cargo helicopters with and without external load for the ADS-33E specification.

The addition of a heavy external load can result in a substantial degradation in the quality of attitude and translational control. One notable feature is a prominent oscillatory response mode in the frequency range of manual control activity. This oscillatory mode is associated with the pendulum action of the load, and couples with the fundamental

response of the basic airframe stability command augmentation system (SCAS) system. Therefore, a fundamental understanding of the dynamics of external loads as they relate to aircraft handling is essential to development of criterion parameters. Much of the existing literature on external loads was produced during the 1970s, and mainly describes the dynamics. The effect of an externally slung load on handling qualities, particularly in terms of contemporary metrics and standards, has not been studied in detail prior to this effort.

The attitude bandwidth criterion has been found to be an effective means to ensure that the short-term attitude response is sufficiently crisp and predictable to maneuver with adequate aggressiveness and precision when flying without an external load. The piloted simulator experiment was conducted to test the applicability of attitude-bandwidth type criteria when a heavy external load is attached. Analyses of the simulation data and pilot commentary revealed that the bandwidth of the translational rate response is a better handling-qualities metric than attitude bandwidth for helicopters with external loads. This is discussed throughout the report and in appendix E.

1.1 Technical Approach

The technical approach consisted of:

- (1) Develop configurations that test the hypothesis that a criterion based on attitude-bandwidth can be extended from basic helicopters to those carrying external loads. Continue to develop new configurations to answer questions that arise during the course of the simulation. Develop additional or revised criteria as necessary.
- (2) Define critical tasks with external load, especially in the degraded visual environment (DVE).
- (3) Develop simulation math models based on the CH-47 tandem rotor cargo helicopter, with a single-point suspension of nonaerodynamic external loads.¹ Two math models were formulated: one complete model for the VMS and one simplified model that was used primarily for analysis. Extensive correlations were made to ensure that the two models were in agreement. Both models were flown on the VMS, but the more complete model was used for all formal data acquisition.
- (4) Use the NASA Ames VMS, large-amplitude motion, four-window visual, and fast host computer.
- (5) Variations were made in load geometry and load mass characteristics
- (6) Obtain Cooper-Harper handling qualities ratings (HQRs) for configurations using the previously defined tasks

The aircraft math model was based on the CH-47D Chinook airframe and propulsion system. The flight control system was modified to reflect a generic attitude-command/attitude-hold (ACAH) response type in pitch and roll. An altitude-hold or height-hold (HH) system was also implemented and used for all data runs. The use of

¹ A few two-point suspension cases were briefly examined in this study.

ACAH + HH is consistent with the requirement for response type in ADS-33D/E for flight in a DVE. Specifically, when the usable cue environment (UCE) is greater than 1, ADS 33D/E requires an ACAH + HH response type for Level 1 handling qualities. The simulation visual scene was measured using the techniques in ADS-33D/E, resulting in UCE = 2 (albeit very close to UCE = 1), which is judged to be due to a lack of sufficient fine grained texture (see ref. 3 for more details on UCE).

The simulator experiment described herein uses the NASA Ames VMS facility at Moffett Field, California. This facility provides large-amplitude motion, a four-window ESIG-2000 visual system, and a generic cockpit with controls and instruments representative of a large cargo helicopter.

1.2 Organization of Report

The purpose of the research was to develop cargo helicopter handling-qualities criteria to be used in the upgrade from ADS-33D to ADS-33E. The criteria that resulted from this effort are presented in section 2. A brief overview of the experimental protocol and limitations are also presented in section 2. More detailed descriptions of the simulations and tested configurations are given in appendices A through D. The analysis of the data that led to the criteria in section 2 is presented in section 3. Although the experiments were almost entirely focused on external loads, some load-off data were obtained. Those results are presented in section 4. A brief summary of the external-load results is presented in section 5. The external-load criteria derived in this report are based on the translational rate response. Considerable effort was expended to derive criteria based on the attitude response. A summary of that effort is given in appendix E.

2 Development of External-Load Criteria

2.1 Overview of Simulation

The criteria described in this report were derived based on the results of two external-load simulations conducted on the NASA Ames VMS: Slung Load 4 and Slung Load 5 (SL4 and SL5).

The results obtained from the simulation apply to operations in the DVE because the simulation UCE was equal to 2. The UCE methodology for quantifying the visual cueing environment is presented in ref. 2 and 3. The UCE = 2 rating implies that a rate system that is normally rated as Level 1 would receive HQRs consistent with Level 2 because of a lack of adequate visual cueing (usually insufficient fine-grained texture). The UCE = 2 rating on the simulation was determined using the methods presented in ref. 1 (ADS-33E).

The basic inner-loop augmentation was ACAH in pitch and roll, and Altitude-Hold was active in the vertical axis. This is consistent with the ADS-33D/E requirements to achieve Level 1 in the DVE when the measured UCE = 2.

The NASA Ames VMS is probably the only existing facility that is capable of a reasonably valid representation of external-load operations, by virtue of its large-amplitude motion system. However, even with the large field-of-view visual, and large-amplitude lateral and vertical motion, the cueing was somewhat compromised compared

to the real world. Motion cues have a significant impact on the pilot's impressions of the swinging load, and even with the maximum possible motion gains, the actual accelerations at the cockpit were approximately one-tenth of those experienced in the real world. Nonetheless, the pilots commented that the motions were representative of their experience in carrying external loads, and that the motions were beneficial in the conduct of their evaluations.

The pilots were not able to see the load, and therefore had to deduce what the load was doing from motion and visual cues. The hover altitude was fixed at 50 feet so that the visual cues were constant for all runs. This artifact resulted in the longer slings being partially underground. The pilots were not able to observe this artifact.

The motion gains in SL5 were appreciably higher than in SL4, a result of motion gain-optimization process that concentrated on the precision hover maneuver in SL5. SL4 tasks included precision hover, normal departure/abort, and lateral reposition (see appendix C3). The VMS cab was oriented to maximize longitudinal motion for the normal departure/abort task, and was re-oriented 90 degrees to maximize lateral motion for the precision-hover and lateral reposition task. Only the precision-hover maneuver was accomplished in SL5, because the results of SL4 indicated that this was the most critical maneuver. The reason for this is that the effect of the swinging load is most noticeable when attempting to accomplish very precise position control. All data correlations in this report are based on the precision hover task. The pilot ratings for the precision-hover and other maneuvers are given in appendix B.

All results discussed herein are based on a high density load suspended from a single point at or directly below the helicopter center of gravity (c.g.). Load aerodynamics were not simulated.

2.2 Proposed Criteria for ADS-33E Handling Qualities Specification – Helicopters with External Load

2.2.1 Quantitative Criteria – Helicopters with External Load

This section presents the quantitative handling-qualities criteria for rotorcraft with external loads that resulted from this study. Further work should be accomplished to verify these criteria in a flight-test environment. Such testing should also examine the ability to reliably measure the criterion parameters. This work should be accomplished before the quantitative criteria are included as an update to ADS-33E (ref. 2). When included in ADS 33, it is expected that the quantitative criteria would be used in lieu of the attitude bandwidth criterion for configurations with an external load.

In addition to the quantitative criteria, flight- test maneuvers and performance criteria were developed for cargo helicopters with external load. These maneuvers and performance criteria are given in appendix C and have been included in ADS-33E.

The external-load bandwidth criteria provide guidance as to what is required to obtain Level 1 pilot ratings with load on in the DVE, in addition to meeting the load-off handling-qualities criteria in ADS-33. These external-load criteria are based on the assumption that the basic rotorcraft without an external load is Level 1. It is cautioned that the combination of not meeting the external-load criteria, and a rotorcraft that is Level 2, load off, will probably result in Level 3 handling qualities in the DVE.

The effect of the external load on handling qualities was found to be a strong function of the load-mass ratio – the ratio of the mass of the load to the mass of the helicopter plus load (m_L / m_{Total}). The effect of an external load on helicopter handling qualities was found to be significant when the load-mass ratio is equal to or greater than 0.33 of the total mass, i.e., $m_L / m_{Total} \geq 0.33$.

The handling-qualities criteria specific to rotorcraft with external load are defined in terms of two parameters – translational rate bandwidth and load coupling. These parameters are defined in section 2.3.

The horizontal translation bandwidths shall be as follows for Level 1:

$$\text{Longitudinal } \omega_{BW_{\dot{x}}} \geq 0.44 \text{ radians per second (rad / sec)}$$

$$\text{Lateral } \omega_{BW_{\dot{y}}} \geq 0.59 \text{ rad / sec}$$

The frequency range of favorable load coupling shall be as follows for Level 1:

$$\text{Longitudinal } \Delta\omega_{L_x} \geq 0.39 \text{ rad / sec}$$

$$\text{Lateral } \Delta\omega_{L_y} \geq 0.73 \text{ rad / sec}$$

Not meeting these criteria will result in handling qualities that are no worse than Level 2 with an externally slung load in the DVE, as long as the load-off handling qualities are Level 1. There is no Level 2-3 limit that is specifically due to external load.

The proposed criterion parameters are defined in section 2.3. There are four definitions of bandwidth, two based on phase margin and two based on gain margin. All of these must be greater than the values specified by the above criteria.

It is recognized that it may be difficult to obtain Bode plots of translational rate-to-cyclic response with sufficient accuracy and resolution to accurately measure these parameters. Therefore, it is acceptable to use an analytically derived Bode plot if the math model used to generate the Bode plot has been shown to correlate with flight data for input-output responses other than the translational rate to cyclic. For example, if the analytically derived Bode plots for pitch and roll attitude to cyclic inputs (with external load) is well correlated with flight-test data, the math model may be assumed to be acceptable to calculate the translational-rate criterion parameters.

2.2.2 Flight-Test Maneuvers – Helicopters with External Load

Testing with external loads should be accomplished with $m_L / m_{Total} = 0.33$ or the maximum load that will be used for operational missions, whichever is less. In addition, external load testing should be accomplished in the DVE, unless this is not part of the required operational missions. The recommended maneuvers are given in appendix C.

The existence of an external load will degrade handling qualities, and it is not practical to require Level 1 as defined by averaged HQRs less than 3.5 ($\overline{HQR} \leq 3.5$) for heavy loads. Simulation studies have shown that it is reasonable to expect average ratings of 4 for $m_L / m_{Total} = 0.33$. On that basis, the requirement for Level 1 during tests with external

loads in the DVE, with $m_L / m_{Total} = 0.33$, is relaxed so that the average HQR (\overline{HQR}) must be no greater than 4 (compared to 3.5 load-off).

If $m_L / m_{Total} > 0.33$, the simulation studies showed that the ratings degrade linearly with increasing load-mass ratio (see section 3.3), the caveat being that the averaged ratings did not exceed 6.5 for any of the tested cases. That is, the effect of a heavy swinging load never caused problems severe enough to be classified as Level 3 (as long as the load-off helicopter was Level 1).

Conversely, it was shown that for load-mass ratios less than 0.25, the effect of the load was reduced to the point where averaged HQRs of 3.5 or better were achievable. On the basis of those results, the maximum allowable averaged HQR as a function of load-mass ratio is as follows:

<p>For $m_L / m_{Total} > 0.33$, $\overline{HQR} \leq \left[4.0 + 5.2 \left(\frac{m_L}{m_{Total}} - 0.33 \right) \right]$</p> <p>For $0.25 \leq m_L / m_{Total} \leq 0.33$, $\overline{HQR} \leq 4.0$</p> <p>For $m_L / m_{Total} \leq 0.25$, $\overline{HQR} \leq 3.5$</p>
--

In addition to testing for acceptable handling qualities, it should be determined that any load oscillations that occur during deceleration to hover are damped quickly enough so that they do not interfere with the ability of the ground crew to safely detach the load without damaging it, in a reasonable period of time.

2.2.3 Quantitative Criteria – Cargo Helicopters with Internal Load

Based on the data from the SL4 and SL5 simulations, the roll-axis bandwidth criterion for low speed and hover and UCE = 2 and/or divided-attention operations in ADS-33E has been increased from 0.50 rad/sec (ADS-33D) to 1.0 rad/sec (ADS-33E). This is independent of the size of the helicopter. Data to support this revision are given in section 4.

2.3 Development of Criteria for External Load

The criteria developed in this study apply to low-speed and hover tasks, i.e., tasks where the groundspeed is, for the most part, under 45 knots (kts). The criteria are based on the precision-hover tasks as accomplished in two simulations (SL4 and SL5). Other more aggressive tasks were accomplished in SL4 (lateral reposition and normal departure/abort as described in appendix C). It was concluded at the end of SL4 that the precision-hover task was the most critical task in terms of handling qualities because the perturbations that result from the swinging load are much more noticeable and intrusive when trying to accomplish a precision station-keeping task. The pilot ratings in appendix B (table B-1) confirm that the HQRs for precision hover were consistently worse, or at least no better than for the more aggressive tasks. The SL5 simulation focused entirely on the precision-hover task.

Analysis of simulation data (SL4 and SL5) for variations in external load and flight-control-system characteristics has shown that pilot opinion is strongly impacted by

changes in the characteristics of the longitudinal and lateral *translational-velocity* response. This is in contrast to the load-off case where pilot opinion is best correlated with *attitude*-response characteristics. Without an external load, the attitude and translational-rate responses are highly correlated. This is not the case with an external load, where the phasing of the translational-rate and attitude responses is highly dependent on the sling geometry, load mass, and flight control system.

Recall that the basic hypothesis that was used to guide the development of test configurations for this experiment was that the attitude-bandwidth criteria for load off could be extended to load on. Considerable analysis was accomplished in an attempt to correlate the pilot-rating data with various definitions of attitude bandwidth (see appendix E). This was ultimately unsuccessful, leading to correlation efforts using the characteristics of the surge and sway (translational velocity \dot{x} and \dot{y}) responses.² Considerably improved correlations with pilot ratings and commentary resulted from that effort. The basis for the resulting criteria is described using the elementary pilot vehicle-analysis procedures presented in the following paragraphs.

A closed-loop pilot-vehicle analysis of the precision-hover task with ACAH augmentation indicates that one way to obtain a stable solution is to feedback position (x) and velocity (\dot{x}) to the longitudinal cyclic (see ref. 3). The block diagram in figure 2 illustrates this model of piloted closed loop control.

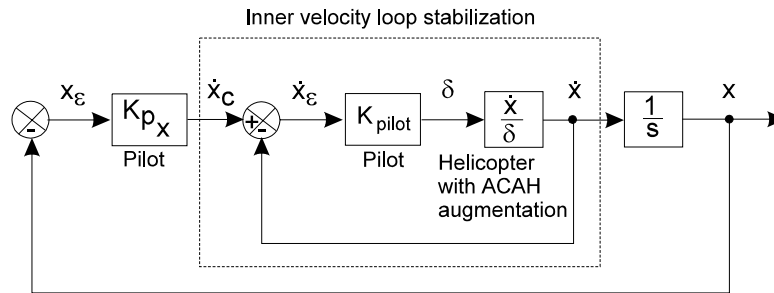

Figure 2. Closed-Loop Piloted Control in Hover – Helicopter Augmented to ACAH.

Good position control (ability to null x_ϵ) is dependent on the characteristics of the inner velocity loop stabilization, i.e., the ability of the pilot to precisely control speed. It follows that the criteria development effort can be focused on an analysis of the \dot{x} to \dot{x}_c loop closure. That is, the effect of the poles and zeros of \dot{x}/δ and \dot{y}/δ on the velocity loop closure can be identified and correlated with pilot opinion and ratings from the SL4 and SL5 simulation experiments. These pole-zero locations can be related to physical characteristics such as sling geometry (e.g., hook-to-c.g. distance and sling length) and flight-control-system characteristics.

The loop closure described by the block diagram in figure 2 is stable as long as the stability augmentation system (SAS) is mechanized to provide an ACAH response type.

² The correlation of pilot rating data with surge-and-sway characteristics was also suggested by pilot commentary that indicated significant concern with those degrees of freedom (see appendix B).

For a rate response type, the \dot{x}/δ and \dot{y}/δ transfer functions exhibit additional phase lag that must be equalized by the pilot.³

A quantitative criterion is not available for rate response types with an external load, so it is necessary to check the handling qualities using specified flight-test maneuvers in the good visual environment (GVE) (see section 2.2.2 and appendix C).

The development of quantitative criteria for external loads with rate response types was not possible because the simulation visual environment was measured to be UCE = 2 (using the techniques in ADS-33D/E). One attempt was made to use a Level 1 rate system with the nominal load, resulting in HQRs of 7–8. This verified that the simulation environment was UCE = 2, because it is well known that Level 1 handling qualities are possible with rate response types in UCE = 1. The remainder of this development includes the implicit assumption of an ACAH response type.

Typical frequency-response and root-locus plots that describe the longitudinal velocity response to longitudinal cyclic input are shown in figure 3 for a helicopter without a load. The effect of adding an external load that is suspended from a single point is shown in figure 4. Comparison of the dynamics in figures 3 and 4 reveals that the short-period mode (ω_{sp}) is only slightly affected, and that the primary effect of the load on the surge response is described by the addition of a lightly damped pole-zero complex pair⁴.

The effect of increasing the pilot gain, K_{pilot} , is indicated by the root-locus plots in figures 3b and 4b. These plots indicate the following results:

- There is an increase in $1/T_{\dot{x}}$, which defines the fundamental speed and path response (load on and off). Higher values of $1/T_{\dot{x}}$ allow for a more predictable velocity response and hence a more stable position loop closure.
- There is a decrease in damping of the short-period mode (load on and off).
- The load-mode pole (ω_{L_p}) is driven toward decreased damping and eventually unstable (load on only).

Good handling qualities would be expected to exist when the pilot is able to augment the basic path mode, $1/T_{\dot{x}}$, without driving the short-period-mode (ω_{sp}) and/or load-mode (ω_{L_p}) poles to unacceptably low damping or unstable.

³ Such equalization involves additional loop closures (e.g., attitude or acceleration feedback) by the pilot.

⁴ The generic effect of external load on the lateral axis is very similar to the longitudinal axis and is therefore not discussed separately.

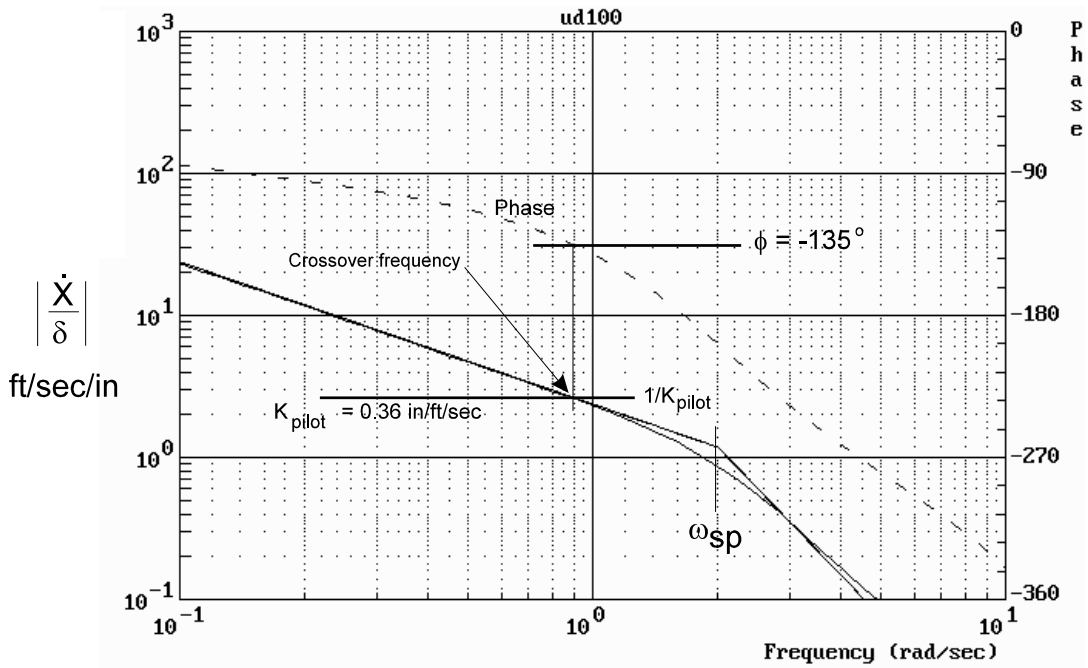

a) Frequency Response of Surge to Longitudinal Cyclic

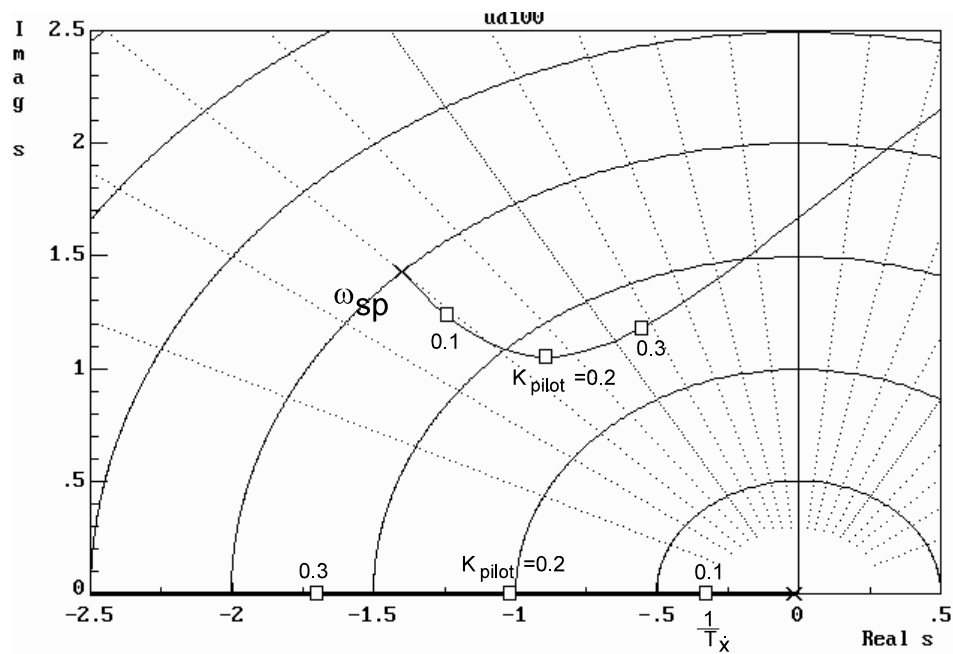

b) Root Locus of Pure Gain Pilot Loop Closure of Speed Loop

Figure 3. Bode and Root Locus for Load Off (Configuration 100).

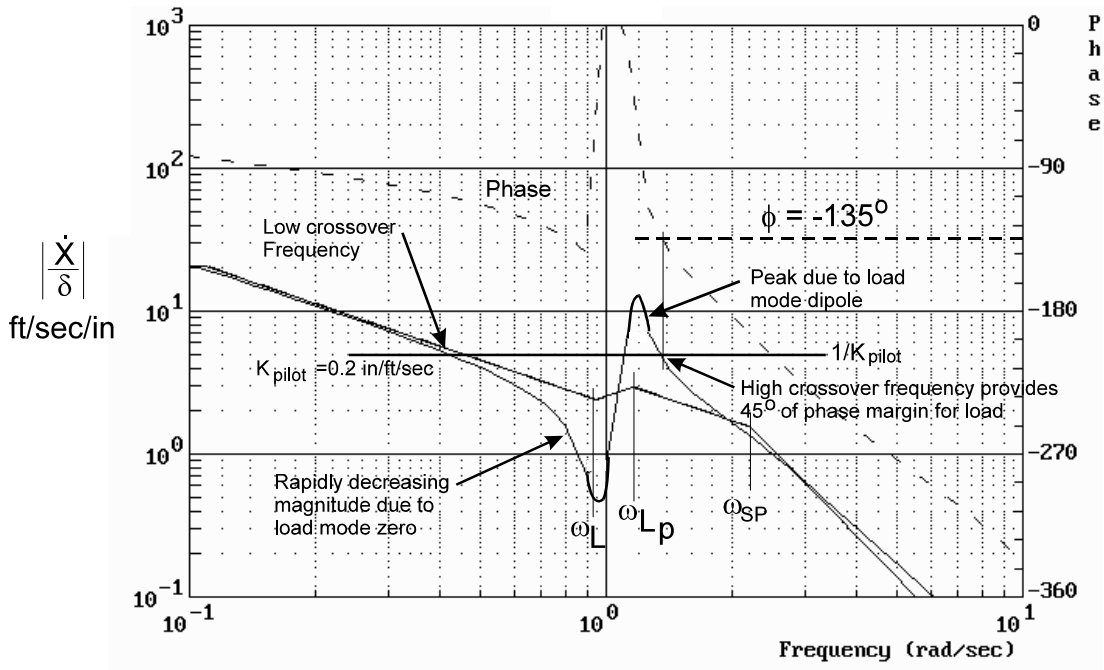

a) Frequency Response of Surge to Longitudinal Cyclic

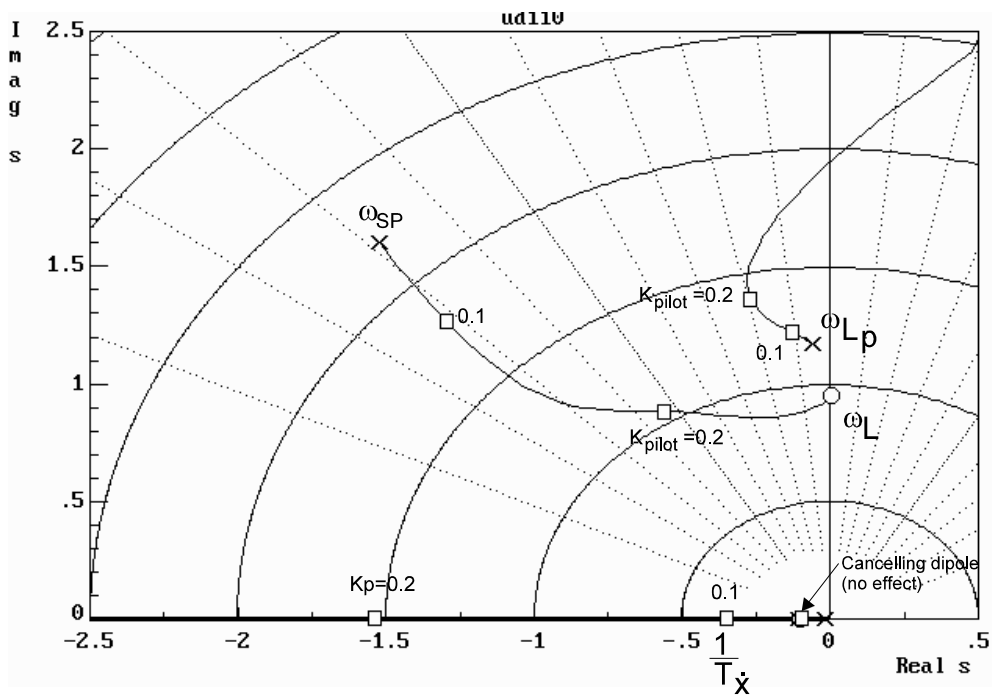

b) Root Locus of Pure Gain Pilot Loop Closure of Speed Loop

Figure 4. Bode and Root Locus with Load On (Configuration 110).

It will be shown that the ability to augment $1/T_{\dot{x}}$ to the level needed to accomplish the task is defined by the translational-rate-bandwidth parameters, $\omega_{BW_{\dot{x}}}$ and $\omega_{BW_{\dot{y}}}$ ⁵. That is, low bandwidth is an indicator that the pilot loop closure will result in low $1/T_{\dot{x}}$. Bandwidth is limited either by stability considerations or by the load-mode zero. The natural frequency of the load-mode zero ω_L is approximated by

$$\omega_L \cong \sqrt{\frac{g}{l_{sling} * m_{helo} / m_{total}}}$$

(where l_{sling} is the length of the sling (hook to c.g. of load)).

Note that when the load mass is much less than the total mass ($m_{helo} / m_{total} \approx 1$), the load-mode zero has the frequency of a classic pendulum, $\omega = \sqrt{g/l}$.

The load-mode pole always occurs in the vicinity of the load-mode zero.

Without an external load, bandwidth is defined in ADS-33D/E as the frequency where the phase margin is equal to 45 deg. or the gain margin is equal to 2 (6 decibels(dB)) in the attitude response. As an example, the piloted crossover in figure 3 is shown to occur at the bandwidth frequency. For the external load case, the translational-rate response is used, and the additional mode induced by the load results in several piloted crossover frequencies, as shown in figure 4. The “low” crossover frequency is akin to the classical piloted crossover illustrated in figure 3. The “high” crossover frequency is due to the load mode. The fact that the pilot gain-line ($1/K_{pilot}$) intersects the load-mode peak indicates that these dynamics are being excited. The phase margin for this high crossover determines the load stability.

The concept of the “high crossover” allows the inclusion of load stability as a factor in the handling-qualities criteria. Without an external load, bandwidth is defined by two parameters, gain and phase margin of the basic augmented aircraft. Adding the effect of an external load requires the addition of two additional parameters, the gain and phase margin associated with the load stability (high crossover). The four criterion parameters are defined as follows.

$\omega_{BW_{\phi_1}}$ - *Phase-margin bandwidth of basic aircraft* - figure 5

The parameter $\omega_{BW_{\phi_1}}$ is the phase-margin bandwidth that is defined as the lowest frequency where the phase passes through -135 deg, as shown in figure 5. This is akin to the load-off case (e.g., fig. 3), and represents the basic path/speed-mode response limit. The first-order pole that defines the fundamental speed and path response ($1/T_{\dot{x}}$) is directly proportional to $\omega_{BW_{\phi_1}}$. If the phase margin does not decrease below 45 deg at frequencies below ω_L , set $\omega_{BW_{\phi_1}} = \omega_L$. This recognizes that the load-mode zero represents an upper

⁵ Bandwidth as used in this report refers to the translational-rate bandwidth unless otherwise noted. As with the attitude bandwidth, it is defined as the frequency for 45 degrees of phase margin.

limit on piloted crossover frequency. This limit occurs because the Bode magnitude decreases rapidly as the crossover frequency approaches the zero at ω_L , and it would require an unreasonably high pilot gain to crossover at frequencies near ω_L (see note at bottom left in fig. 4a).

$\omega_{BW_{\phi_2}}$ - Phase margin bandwidth due to load - figure 6

The parameter $\omega_{BW_{\phi_2}}$ is defined as the low crossover frequency that results when the pilot gain provides 45 degrees of phase margin ($\phi = -135^\circ$) for the load mode. The procedure for determination of that pilot gain, and the resulting $\omega_{BW_{\phi_2}}$, is as follows:

1. Determine the highest frequency where the phase margin is 45 deg (defined as the “high” crossover frequency in figures 4 and 6).
2. Draw a vertical line at that frequency and note where it crosses the magnitude curve. Draw a horizontal line at that magnitude. This represents the pilot gain (its magnitude is $1/K_{pilot}$) required to maintain 45 deg of phase margin for the load mode.
3. Note the lowest frequency where the horizontal line ($1/K_{pilot}$) intersects the magnitude curve (“low” crossover frequency). That value is $\omega_{BW_{\phi_2}}$.

The load-mode dipole results in a peak in the Bode magnitude plot at frequencies above the load-mode zero. This peak represents the surge response of the rotorcraft due to the swinging load. This may be thought of as the first harmonic of the overall response, which is superimposed on the basic path/speed response that is characterized by $1/T_{\dot{x}}$. An increase in the magnitude of the peak of the load response indicates more response in \dot{x} due to the swinging load.

The effect of pilot gain on the crossover frequency can be determined by noting that the crossover frequency occurs when $1 + K_{pilot}G = 0$ or $G = -1/K_{pilot}$ (where G is \dot{x}/δ)⁶.

We can graphically determine the crossover frequency by plotting $1/K_{pilot}$ and \dot{x}/δ on the same grid and noting where they intersect. Normally there is one intersection, and that is defined as the crossover frequency. The conventional definition of bandwidth is when this crossover frequency occurs at -135 deg of phase or 45 deg of phase margin (e.g., see fig. 3).

The additional mode introduced by the swinging load can result in multiple crossover frequencies (e.g., figure 4a, 5, and 6). The phase at the “high” crossover frequency is an indicator of the stability of the load at a given value of pilot gain. If this high crossover results in low or negative phase margin, the pilot is forced to “back off” on his gain to avoid unacceptable oscillations in surge due to the swinging load. There were numerous comments during the SL4 and SL5 simulations regarding the need to back off on gain to avoid exciting the load. When the pilot lowers his gain to stabilize the load, the “low”

⁶ See reference 11 for a more complete description of pilot-vehicle analysis procedures.

crossover frequency must necessarily decrease, resulting in less-precise control over \dot{x} , and hence position.

The previous discussion reveals that $\omega_{BW_{\phi_2}}$ defines the bandwidth limit that occurs as a result of a need to stabilize the load. If $\omega_{BW_{\phi_2}} < \omega_{BW_{\phi_1}}$, speed and position control is limited by load stability (e.g., as in fig. 6). This was more common in the pitch axis, because the high pitch inertia tended to suppress favorable coupling between the load and pitch attitude (see following discussion on $\Delta\omega_L$).

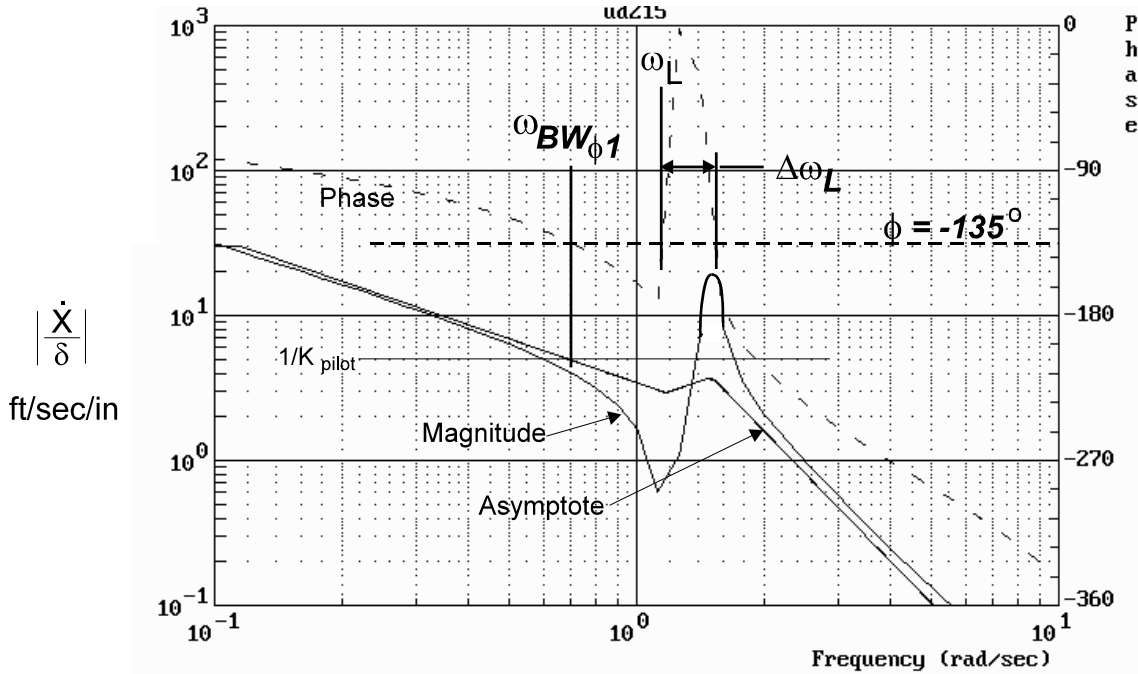

Figure 5. Definition of $\omega_{BW_{\phi_1}}$ and $\Delta\omega_L$.

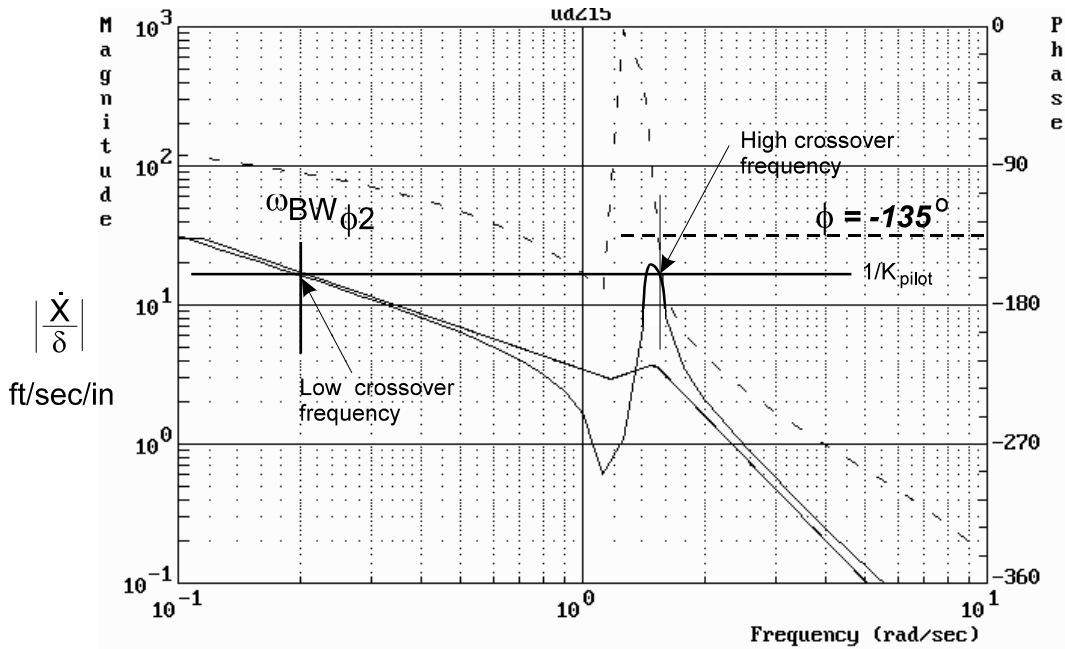

Figure 6. Definition of $\omega_{BW_{\phi_2}}$.

$\omega_{BW_{G_1}}$ - Gain-margin bandwidth of basic aircraft - figure 7

This parameter is equivalent to the gain-margin bandwidth used for load-off handling qualities. The definition of $\omega_{BW_{G_1}}$ is illustrated in figure 7 and is calculated as follows:

- 1) Find the Bode magnitude that occurs at the lowest frequency where the phase equals -180 deg (this is defined as the pilot crossover for neutral stability; $1/K_{pilot} = G$ at the frequency where $\phi = -180^\circ$)
- 2) Find the lowest crossover that occurs if the pilot reduces the gain calculated in step 1 by $1/2$ or $2/K_{pilot}$. This is $\omega_{BW_{G_1}}$.

As an aside, note that this illustration uses the lateral response as an example. A longitudinal example could just as easily have been used, because the dynamics are the same.

$\omega_{BW_{G_2}}$ - Gain-margin Bandwidth due to load - figure 8

This parameter defines the gain margin limit associated with stabilization of the load mode. It is the gain-margin limit that goes along with the $\omega_{BW_{\phi_2}}$ phase-margin limit. The definition of $\omega_{BW_{G_2}}$ is illustrated in figure 8 and is calculated as follows:

- 1) Find the magnitude that occurs at the highest frequency where the phase equals -180 deg. This is the pilot gain ($1/K_{pilot}$) for neutral load stability.
- 2) Find the lowest crossover that occurs if the pilot reduces the gain calculated in step 1 by $1/2$ or $2/K_{pilot}$. This is $\omega_{BW_{G_2}}$.

$\Delta\omega_L$ - Load-coupling parameter - figure 5

The load-coupling parameter, $\Delta\omega_L$, defines the range of frequencies where the phase of the swinging load results in damping of speed and path excursions. The mechanism is as follows. If the load swings forward, the momentum of the load will tend to increase the forward velocity. However, if the forward load swing causes the helicopter to pitch up, the horizontal component of the lift vector will oppose the increase in speed. If the net effect is to damp the overall motion, the load coupling is said to be favorable. Such favorable load coupling manifests as positive phase margin in the vicinity of the load-mode dipole.

The parameter $\Delta\omega_L$ is defined as the range of frequencies where the phase margin is equal to or greater than 45 deg, as shown in figure 5.

Increasing the hook-to-c.g. distance below the vertical c.g. of the helicopter tends to improve favorable load-mode coupling (larger $\Delta\omega_L$), because the effect of the swinging load on pitching moment is increased. Conversely, increasing the pitch moment of inertia tends to reduce $\Delta\omega_L$ since the aircraft does not pitch as much because of the applied moment of the swinging load.

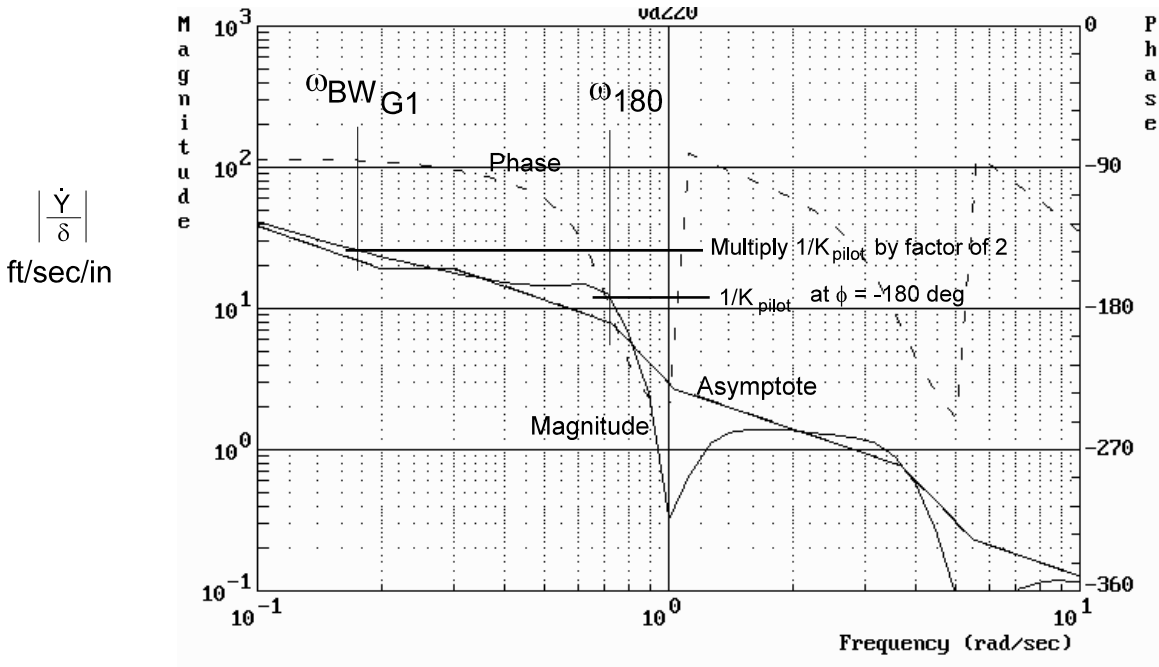

Figure 7. Definition of $\omega_{BW_{G1}}$.

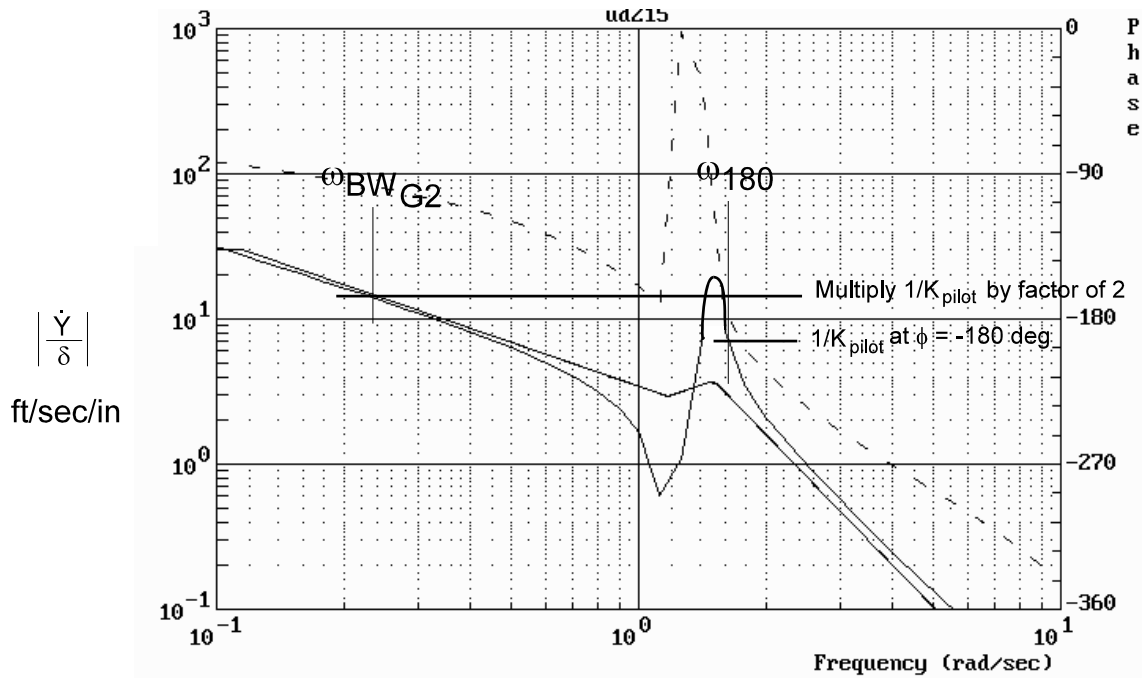

Figure 8. Definition of $\omega_{BW_{G2}}$.

3 Supporting Data

3.1 Tested Configurations

The SL4 and SL5 VMS simulations were accomplished to verify, or if necessary modify, the hypothesis that the handling qualities of helicopters with external load can be specified using an extension of the basic Attitude Bandwidth Criteria in ADS-33D. The required perturbations in attitude bandwidth were achieved through systematic variations in external load parameters as well as a variable lag-lead filter in the flight control system. These parametric variations are summarized as follows.

- Sling length from 20 to 150 ft
- Hook-to-c.g. distance from 0 to 21 ft (below the c.g.)
- ACAH flight control systems with load off Bandwidths of 2.6 rad/sec (ACAH1), 2.0 rad/sec (ACAH2), 1.17 rad/sec (ACAH3), and 0.7 rad/sec (ACAH4). The gains were adjusted so that the pitch and roll bandwidths were identical in hover.
- Effect of lag-lead equalization on ACAH1 and ACAH2
- Effect of ratio of load weight to helicopter weight (load + helicopter weight constant at 46000 pounds (lb)).
- This included some cases with no load, which served as a baseline, and provided data for internally loaded cargo helicopters.
- Effect of variation in roll moment of inertia

The details of the tested external-load configurations are presented in table 1 along with the average Cooper Harper Handling Qualities Rating (HQR) from SL4 and SL5. The configurations are grouped in table 1 according to the parameter being varied. A more complete description of the configurations is given in appendix A.

3.2 Correlation with Bandwidth and Load-Coupling Parameters

The pilot rating data from SL4 and SL5 for the precision hover task are plotted on a grid of bandwidth vs. the load-coupling parameter, $\Delta\omega_L$, in figures 9 and 10 for the nominal 16,000-lb load.

The pilot ratings (table 1) indicate that with a load-mass ratio of 0.33 or greater (16000 lb or greater load) it was not possible to achieve the commonly accepted definition of Level 1 ($\overline{HQR} \leq 3.5$). A review of the pilot commentary reveals the cause to be the uncommanded motions of the rotorcraft resulting from the swinging load. With lighter loads these motions were less objectionable, and average HQRs of 3.5 or better were common. The effect of load mass is further discussed in section 3.3.

The Level 1-2 boundaries shown in figures 9 and 10 were relaxed to HQR = 4 based on the fact that desired performance was achieved, and minor but annoying deficiencies are inevitable when carrying heavy loads in the DVE.

With only one exception, the pilot ratings never were worse than 6.5. Therefore, a Level 2-3 boundary could not be derived. Decreasing bandwidth resulted in a gradual degradation in HQR, whereas unfavorable load coupling was found to be more objectionable.

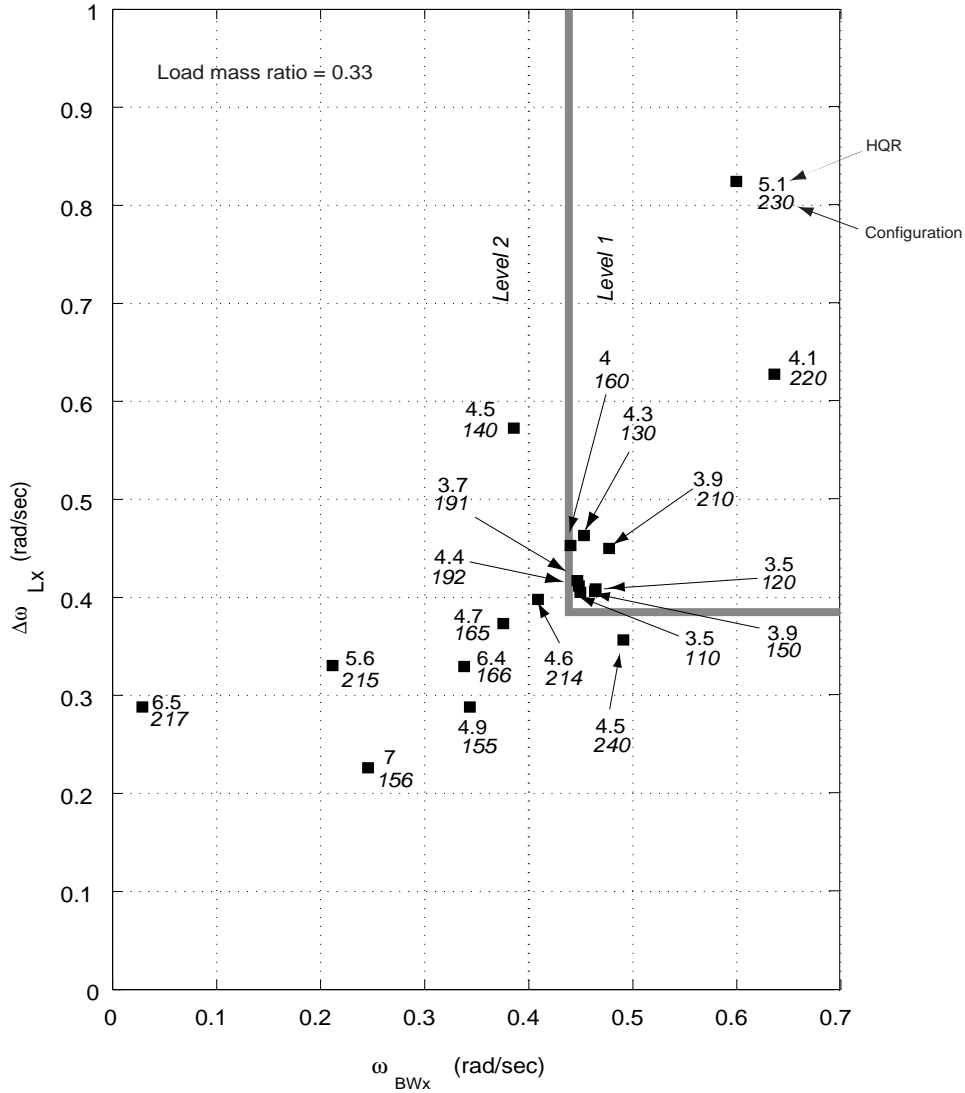

Figure 9. Correlation of Cooper-Harper Pilot Rating Data for Longitudinal Axis.

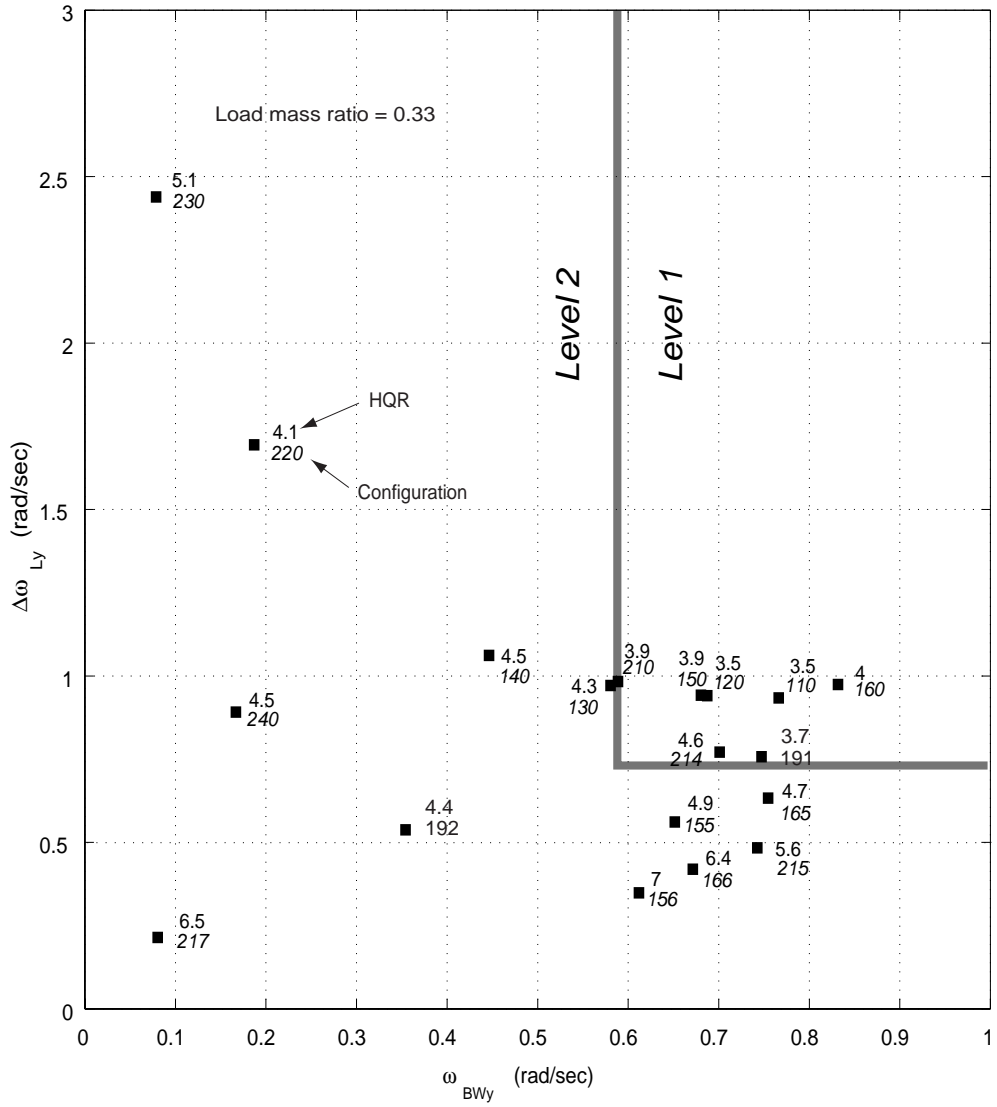

Figure 10. Correlation of Cooper-Harper Pilot Rating Data for Lateral Axis.

Table 1. Summary of External-Load Configurations and Pilot Ratings from VMS Piloted Simulation Experiments

Parameter	Configuration	SAS	Sling Length	Hook-to-c.g. Dist.	(Lead)/(Lag)	lxx	Wload	HOVER							
								ft	ft	(1/T1)/(1/T2)	slug-ft^2	lbs	Avg HQR	Avg HQR	Avg HQR
													SL 4	SL 5	Overall
Length of Sling	160 (baseline)	ACAH1	20	7		37200	16000	4.2	3.8	4					
	110	ACAH1	31	7		37200	16000	3.4	4.3	3.5					
	120	ACAH1	48	7		37200	16000	3.2	4	3.5					
	130	ACAH1	79	7		37200	16000	4	4.6	4.3					
	140	ACAH1	150	7		37200	16000	4.7	4.2	4.5					
	240	ACAH2	54	7		37200	16000	4.5		4.5					
Hook-to-C.G. Distance	217	ACAH2	20	0		37200	16000		6.5	6.5					
	215	ACAH2	20	2		37200	16000	5.7	5.3	5.6					
	214	ACAH2	20	5		37200	16000	4.5	5	4.6					
	210	ACAH2	20	7		37200	16000	3.5	4.3	3.9					
	220	ACAH2	20	14		37200	16000	4.1	4	4.1					
	230	ACAH2	20	21		37200	16000	5.1	4.5	5.1					
Lag-Lead or Advanced Flight Control System (AFCS)	160	ACAH1	20	7		37200	16000	4.2	3.8	4					
	165	ACAH1	20	7	(2.0)/(1.6)	37200	16000	4.7		4.7					
	166	ACAH1	20	7	(2.0)/(1.3)	37200	16000	6.4		6.4					
	150	ACAH1	50	7		37200	16000	3.9		3.9					
	155	ACAH1	50	7	(2.0)/(1.6)	37200	16000	4.9		4.9					
	156	ACAH1	50	7	(2.0)/(1.3)	37200	16000	7		7					
Roll Inertia	160	ACAH1	20	7		37200	16000	4.2	3.8	4					
	191	ACAH1	26	7		84000	16000		3.7	3.7					
	192	ACAH1	27	7		228000	16000		4.4	4.4					
Load Weight (Load + Helo = 46000 lb)	295	ACAH2	20	7		37200	4000		3.3	3.3					
	293	ACAH2	20	7		37200	8000		3.3	3.3					
	294	ACAH2	20	7		37200	12000		3.7	3.7					
	210	ACAH2	20	7		37200	16000	3.5	4.3	3.9					
	290	ACAH2	29	7		37200	27600	5.5	5.5	5.5					
	195	ACAH1	20	7		37200	4000		2.4	2.4					
	193	ACAH1	20	7		37200	8000		3.2	3.2					
	160	ACAH1	20	7		37200	16000	4.2	3.8	4					
	189	ACAH1	20	7		37200	27600		5.3	5.3					

The Level 1-2 boundaries shown in figures 9 and 10 provide a reasonably good separation for cases rated worse than $HQR = 4$ and those that were rated better. Cases that are rated Level 2 and fall in the Level 1 region in one axis, tend to fall in the Level 2 region in the other axis (where Level 1 is defined as $HQR \leq 4.0$). For example, case 230 falls in the Level 1 region for the longitudinal axis and the Level 2 region for the lateral axis. It is rated Level 2 ($\overline{HQR} = 5.1$).

The effects of sling geometry, load mass, flight control system, and roll moment of inertia are isolated and discussed in the following paragraphs.

3.3 Effect of Load-Mass Ratio

As would be expected, the load-mass ratio (mass of load divided by total mass) strongly affected handling qualities. When excited, the swinging load resulted in un-commanded translational motions, which were directly proportional to the load-mass ratio. A typical pilot comment for the precision hover task follows:

“When I would bring it to a stop, and try to back out of the loop during a hover, the oscillations of the airframe would cause the aircraft to translate fore or aft or left or right, depending on which way the load was going, which would take the aircraft out of the desired box.”

The load also disturbed the pitch and roll attitude, as evidenced by the following pilot commentary:

“I put an input in and then the load would respond and I could feel a lateral acceleration, like I was being pulled sideways. And then some time after that, it seemed like I would get a roll in the opposite direction, kind of a stabilizing effect.”

These effects scale directly with the load-mass ratio since a heavier load contributes more momentum to the system. As noted by the comment, the effect of the load on the aircraft response can be favorable. This effect is captured by the load-coupling parameter, $\Delta\omega_L$.

Decreasing the weight of the load results in a decrease in the load-coupling parameter in the longitudinal and lateral axes, as shown in figure 11, because a lighter swinging load does not impose a sufficiently large moment on the rotorcraft to provide the stabilization noted previously above. This results in small values of $\Delta\omega_L$ that are in the Level 2 region. However, the light load also does not disturb the helicopter sufficiently for the pilot to be concerned so that the HQRs are Level 1. Because of this, the Level 1-2 boundaries derived in figures 9 and 10 apply only when the load-mass ratio is sufficiently large ($m_L / m_{Total} = 0.33$).

It is not possible to determine the effect of increasing m_L / m_{Total} beyond 0.33 with confidence from the available data. Only two configurations with load weight greater than 16000 lb were investigated (configurations 189 and 290), and these were both rated as Level 2. These Level 2 ratings may be due to the decreased bandwidth in the longitudinal axis (fig. 11a) or simply due to the large disturbances caused by the swinging of the very heavy load ($m_L / m_{Total} = 0.6$). Most likely it is a combination of these two effects.

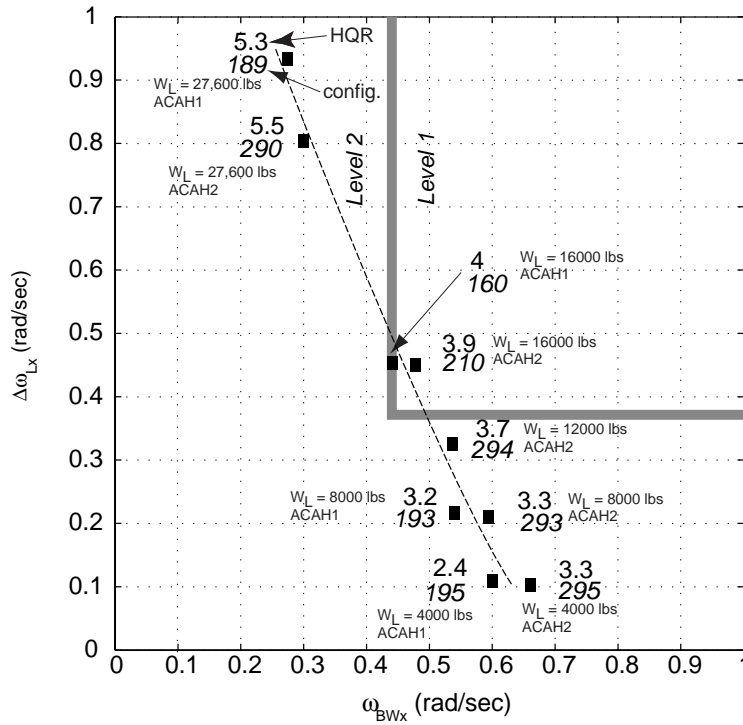

a) Effect of Load Mass Ratio - Longitudinal Axis

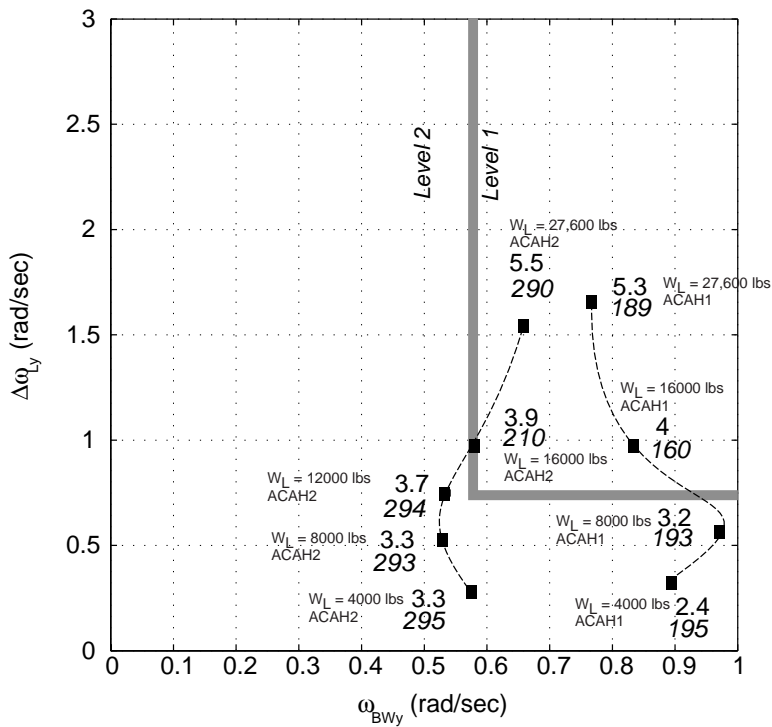

b) Effect of Load Mass Ratio - Lateral Axis

Figure 11. Effect of Load-Mass Ratio.

The configurations where load weight was independently varied (sling length and hook-to-C.G., held constant at nominal values) indicate an essentially linear trend in pilot rating vs. load-mass ratio, as shown in figure 12. The effect of increased attitude bandwidth (ACAH1 vs. ACAH2) appears to be unimportant for load-mass ratios greater than 0.18 for these “nominal” cases (i.e, 20-ft sling and 7-ft hook-to-C.G. distance).

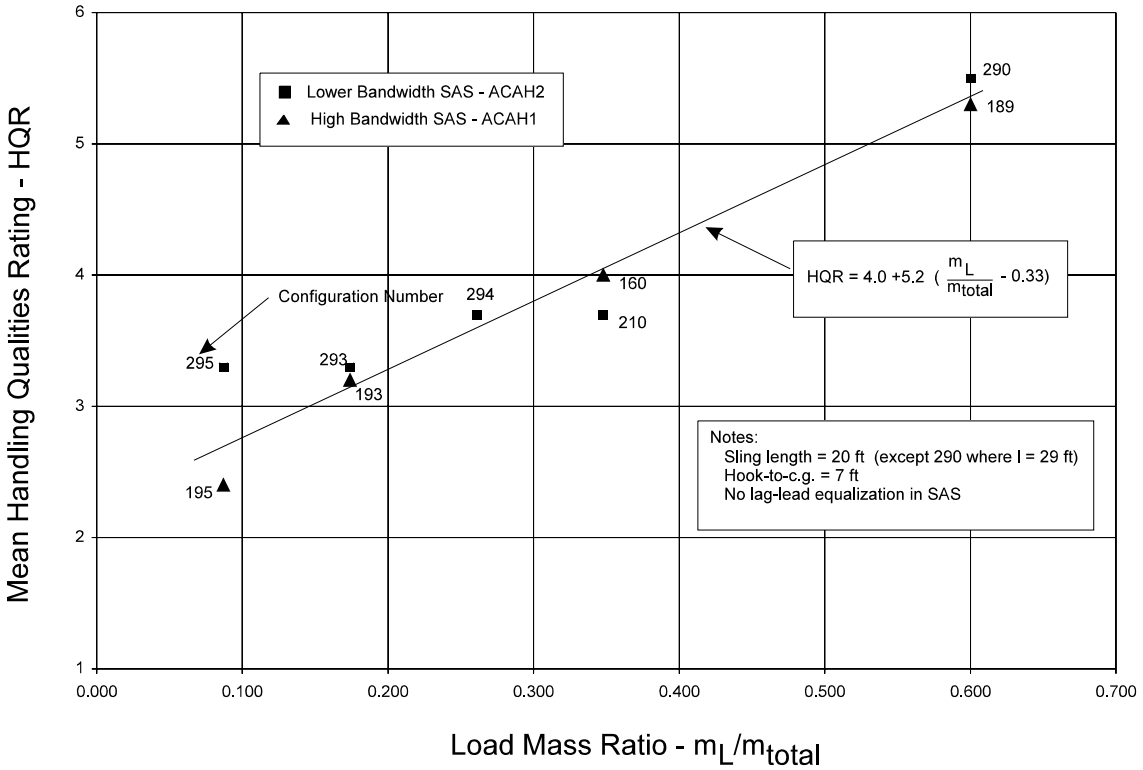

Figure 12. Effect of Load-Mass Ratio on HQR.

These data indicate that pilot ratings degrade as an essentially linear function of increasing load weight. It follows that the proposed quantitative criteria apply only for the tested load weight, $m_L / m_{Total} = 0.33$. The criteria are too stringent for lighter loads and too lenient for heavier loads. Until more comprehensive criteria are developed, it will be necessary to determine the handling qualities for lighter and heavier loads using the maneuvers in appendix C, as specified in section 2.2.2. The HQRs obtained from such evaluations are allowed to degrade according to the formula in figure 12 when $m_L / m_{Total} \geq 0.33$.

The flight-test criterion in section 2.2.2 allows the average HQR to degrade with increasing load-mass ratio per the formula in figure 12 when $m_L / m_{Total} > 0.33$.

Conversely, when $m_L / m_{Total} \leq 0.25$, the data in figure 12 indicate that the HQRs should be no worse than 3.5.

From a design standpoint, meeting the quantitative criteria developed herein for $m_L / m_{Total} = 0.33$ provides reasonable assurance that the best possible handling qualities are achieved for all load weights, the caveat being that for much heavier loads, the best

possible handling qualities may not be very good. For such cases, the pilots are required to “fly the load.” Pilots who fly very heavy loads refer to moving the helicopter over the load to damp the motion. It is normally not possible to do this in the DVE, since the pilot cannot see the load (especially with night-vision goggles). In that case, there seems no choice but to live with the increased workload and degraded performance. Meeting the bandwidth and load coupling criteria presented previously ensures that the workload is as low as possible.

3.4 Effect of Sling Length

The results obtained for variations in sling length are shown in Figure 13. These data indicate that the pilot commentary and ratings were not highly sensitive to sling length.

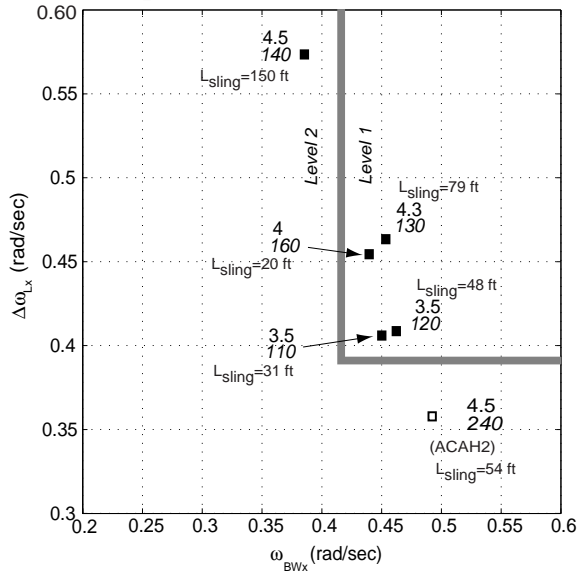

a) Effect of Sling Length - Longitudinal Axis, ACAH1 Unless Otherwise Noted

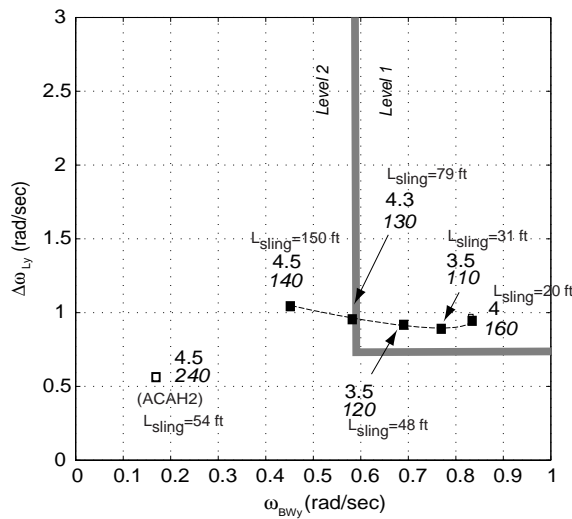

b) Effect of Sling Length - Lateral Axis, ACAH1 Unless Otherwise Noted

Figure 13. Effect of Sling Length.

Longitudinal axis – Increasing the sling length from 20 to 79 ft caused only small variations in $\Delta\omega_{LX}$ and bandwidth (see fig. 13a). A substantial increase in $\Delta\omega_{LX}$ occurred when the sling length was increased to 150 ft (configuration 140). The averaged pilot ratings did not vary significantly with sling length ($\overline{HQR} = 3.5$ for 20-ft sling length and $\overline{HQR} = 4.5$ for 150-ft sling length). A detailed examination of the data indicates a small but steady degradation in pilot rating with increasing sling length. Case 160 (20-ft sling) received numerous ratings of 3 and one 2.5. Case 140 (150-ft sling) was frequently rated 4.5 to 5, and never better than 3.5. The subtle nature of the degradation with a long sling (due to decreased lateral bandwidth) required a large number of runs to identify.

There does not appear to be a handling-qualities cliff associated with sling length. There were numerous pilot comments that the system is well behaved if the pilot backs out of the loop (all sling lengths), because of the favorable load coupling ($\Delta\omega_L$) that existed for all the cases where sling length was varied.

All but one of the sling length variation cases were run with the higher-attitude bandwidth (ACAH1). Case 240 was run with a 54-ft sling and ACAH2 ($\overline{HQR} = 4.5$). Comparison with configuration 120 (48-ft sling and ACAH1, with $\overline{HQR} = 3.5$) indicates that the effect of the attitude SAS is significant for longer slings. This is discussed further in section 3.6.

Lateral axis – Increasing the sling length resulted in a monotonic decrease in bandwidth at approximately constant $\Delta\omega_{LY}$ (fig. 13b). The primary pilot complaint for configuration 140 (150-ft sling) was lack of predictability, which is consistent with the decreased lateral bandwidth.

3.5 Effect of Hook-to-C.G. Distance, l_{hook}

The nominal value of l_{hook} was 7 ft, which is the geometry that is normally used by the U.S. Army when carrying external loads on the CH-47. A range of hook-to-c.g. distances between 0 and 21 ft was tested. All the hook-to-c.g. variations were run with the lower attitude bandwidth system (ACAH2).

Increasing l_{hook} from 0 to 21 ft resulted in a corresponding increase in the load-coupling parameter, $\Delta\omega_L$, from very low to very high values, as shown in figures 14a and 14b. This is a direct result of the increase in moment transmitted to the rotorcraft from the swinging load as l_{hook} is increased. In the longitudinal axis, the translational rate bandwidth increases steadily with l_{hook} (figure 14a), which would be expected to result in improved handling qualities in that axis. In the lateral axis, ω_{BW_y} increases up to $l_{hook} = 5 \text{ ft}$, and abruptly decreases for values greater than 5 ft (fig. 14b). The decrease in bandwidth for $l_{hook} > 7 \text{ ft}$ would be expected to result in degraded pilot ratings (moves into Level 2 region in fig. 14b). The actual degradations in the average HQR were

somewhat less than might be expected, based on the significant decrease in lateral bandwidth (ω_{BW_y}) shown in figure 14b.

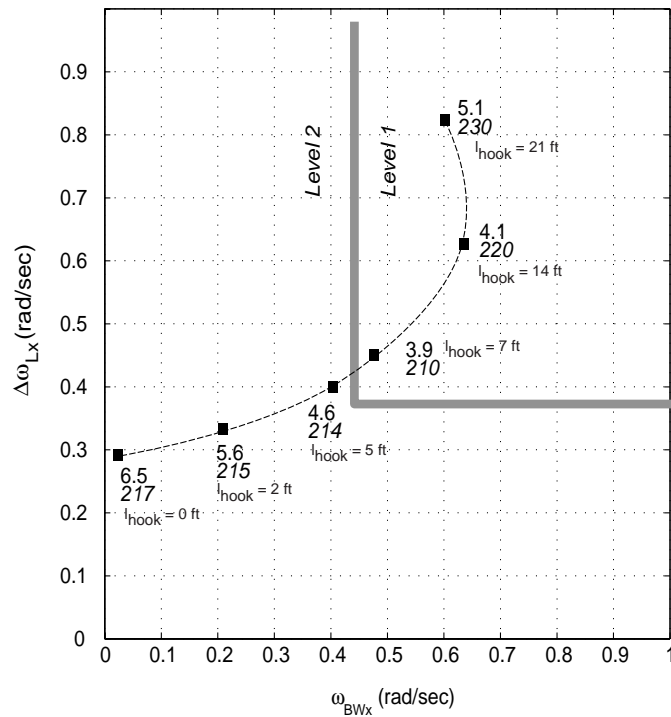

a) Effect of Hook-to-c.g. Distance on Longitudinal Axis, ACAH2

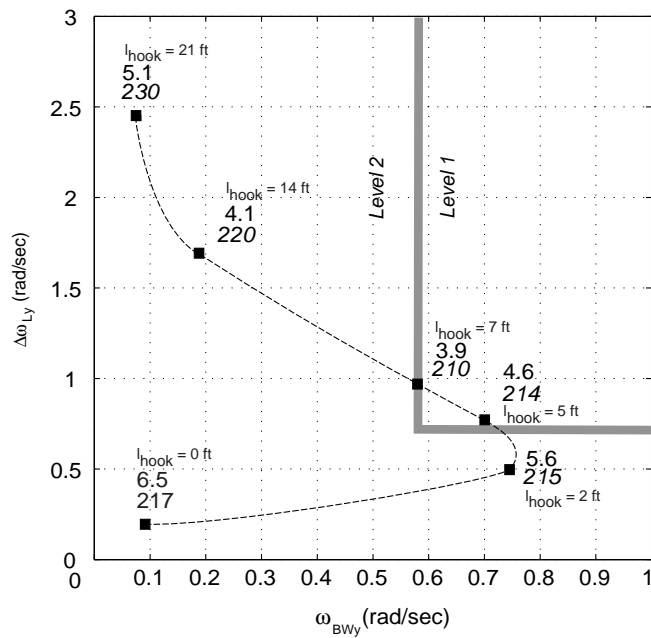

b) Effect of Hook-to-c.g. Distance on Lateral Axis, ACAH2

Figure 14. Effect of Hook-to-C.G. Distance.

The decrease in bandwidth in the lateral axis for $l_{hook} > 5 \text{ ft}$ (fig. 14b) is due to gain-margin limiting. Configuration 220 is severely gain margin limited, but surprisingly the averaged pilot ratings ($HQR = 4.1$) do not indicate a significant degradation in handling qualities⁷. The ratings from SL4 were 5/2/3/4/4/5/5. For SL5 one rating of 4 was obtained from the same pilot (Wilson), who gave it a 2 on SL4. A review of the pilot commentary provides some insight. Pilots Gerdes and Wilson gave the following ratings and commentary for configuration 220 in SL4 (also see appendix B).

Gerdes HQR=5

I'll just call it not predictable because of the effect of the load, and it varies depending on how much you disturb it. I find that I'm trying very hard to enter any maneuver in a way to not start the load swinging, and on a couple of my runs, one of them when I rolled out over the hover point, I did it just right so as I rolled out somehow I just damped the load right out and I couldn't believe how good I did that. And the next one was terrible, so *it's hard to be consistent*.

Wilson HQR = 2

It was one steady smooth transition into the final hover target with very little influence from the load on the aircraft, very, very small perturbations. Felt more than seen. And *it didn't require the pilot to get into the loop*, require myself to get into the loop to chase them around a little bit, they were stable, you know, they weren't divergent, *I just pretty much stayed out of the loop* and let the aircraft bounce around a little bit. Some undesirable oscillations in roll.

These comments suggest that the handling problems depend on how tightly the pilot is in the loop. This can vary from run to run, as noted by Gerdes, who down-rated the configuration based on lack of consistency. Wilson had an entire series where he did not get into the loop tight enough to expose the gain-margin limit problem. He did see a hint of the roll problem, but not enough to down-rate the configuration.

The Level 1 load-coupling characteristics (high $\Delta\omega_L$) caused configuration 220 to be very well behaved if the pilot backs out of the loop (load swing inherently stabilizes the motions). However, the Level 2 bandwidth, because of gain-margin limiting in the lateral axis, makes the configuration susceptible to divergent oscillations if the pilot tries to aggressively control position or speed. The large spread in ratings (2 to 5) is indicative of a handling qualities problem that is highly dependent on pilot technique, which can vary from run to run.

These results expose the subtle nature of gain-margin-limited systems. Caution is advised for configurations that exhibit low bandwidth due to gain margin, but are rated favorably by the pilots. Chances are, the pilots were not sufficiently aggressive during the evaluations to expose the problem.

3.6 Effect of Higher-Order Flight Control System and Attitude Bandwidth

These cases were achieved by adding lag-lead compensation in front of the ACAH1 SAS of configuration 160 (nominal 20-ft sling) and configuration 150 (50-ft sling). The effect of additional lag compensation is seen to cause a decrease in the translational-rate

⁷ The gain-margin limiting was such that $\omega_{BW_{G1}}$ was the limiting parameter (see fig. 7). Also see figure D-48.

bandwidth (ω_{BW_x}) and load coupling ($\Delta\omega_L$) in both the lateral and longitudinal axes in figure 15.

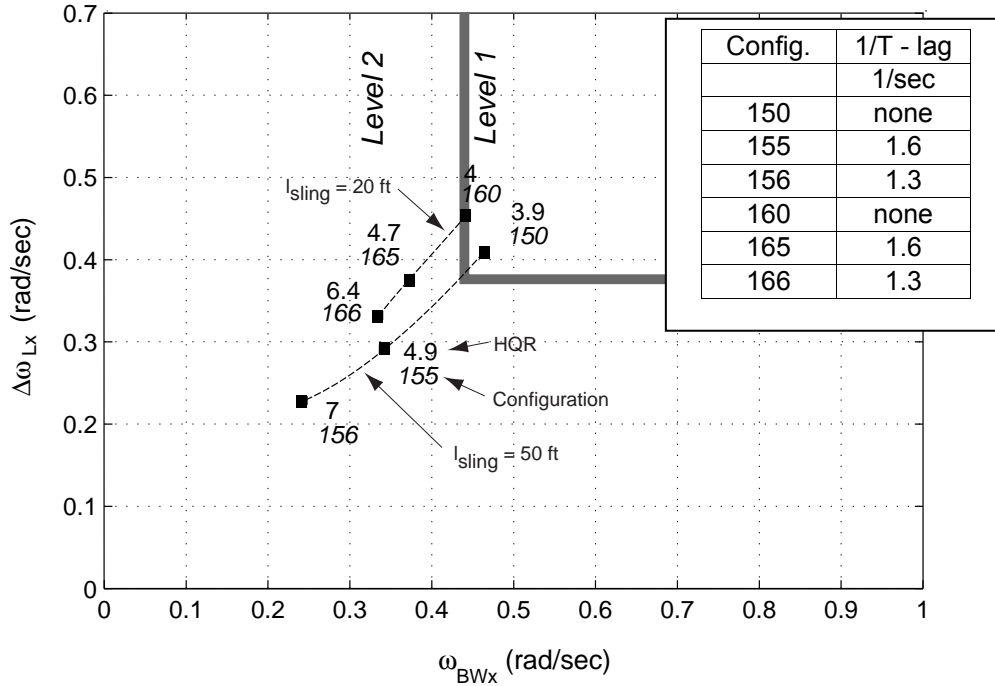

a) Effect of Flight Control System on Longitudinal Axis, ACAH1

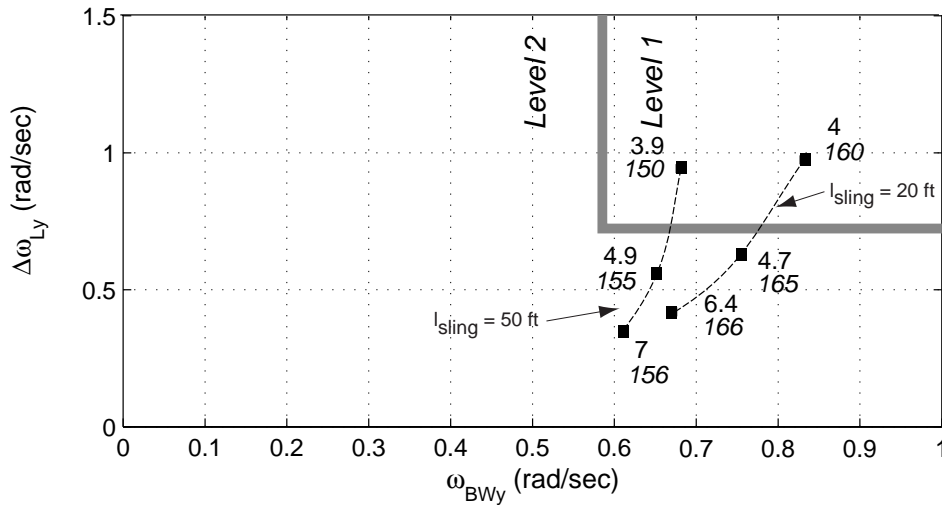

b) Effect of Flight Control System on Lateral Axis

Figure 15. Effect of Lag Lead in Flight Control System.

In all the lag-lead cases the lead inverse time constant was $1/T_{LEAD} = 2.0 \text{ sec}$.

The expected degradation in pilot ratings is seen to occur as the configurations move away from the Level 1–2 boundaries, deeper into the region of predicted Level 2 handling qualities.

These results illustrate that lags in the flight control system can significantly affect handling qualities with an external load, *even though the lags do not adversely affect the attitude bandwidth frequency*. In fact, the original intent of configurations 165 and 166 was to achieve a similar attitude bandwidth to configuration 210 by adding a lag lead to configuration 160.

Table 2 compares the load-on attitude bandwidth of 210 with the lag-lead configurations 165 and 166. Even though the pitch and roll attitude bandwidths of 165 and 166 are equal to or greater than 210, the pilot ratings are noticeably degraded. This was one of the scenarios that led to an understanding that the bandwidth of the attitude response is not a valid handling-qualities parameter for external-load configurations.

Table 2. Effect of Control System Lag Lead on Attitude Bandwidth and HQR

Configuration	$(\frac{1}{T_{Lead}})/(\frac{1}{T_{Lag}})$	Pitch Attitude Bandwidth (ω_{BW_θ} rad/sec)	Roll Attitude Bandwidth (ω_{BW_ϕ} rad/sec)	HQR
210	No filter	1.35	1.09	4.0
165	(2)/(1.6)	1.44	1.25	4.7
166	(2)/(1.3)	1.36	1.17	6.4

The effect of sling length was studied for the lag-lead configurations. The data plotted in figure 15 indicate that increasing the sling from 20 to 50 ft resulted in a decrease in the translational-rate bandwidth. The effect of sling length is compared to the effect of adding a lag-lead filter to the flight control system in table 3.

Table 3. Comparison of Effects of Control System Lag and Sling Length

Configuration	$(\frac{1}{T_{Lead}})/(\frac{1}{T_{Lag}})$	Sling Length ft	HQR
150	(2)/(2)	50	3.9
160	(2)/(2)	20	4.0
155	(2)/(1.6)	50	4.9
165	(2)/(1.6)	20	4.7
156	(2)/(1.3)	50	7.0
166	(2)/(1.3)	20	6.4

Here it is seen that the effect of increasing the sling length from 20 to 50 ft is negligible when compared to the effect of adding a lag-lead filter to the flight control system, even though the lag lead does not significantly impact the attitude bandwidth (table 2).

3.7 Effect of Roll Inertia

The effect of roll inertia on the helicopter was studied briefly with configurations 191 and 192. The baseline configuration (160) was modified by increasing its roll inertia from 37,200 slug ft² to 84,000 slug ft² (configuration 191), and to 228,000 slug ft² (configuration 192). The roll and pitch inertias are equal for configuration 192.

The effect of increasing the roll inertia is to reduce both the bandwidth and the load-coupling parameter, $\Delta\omega_{Ly}$ (see fig. 16). Configuration 192 falls in the Level 2 region for roll and is rated accordingly ($\overline{HQR} = 4.4$). This result is attributed to the decreased load-coupling parameter, $\Delta\omega_{Ly}$, and bandwidth that results when the moment of inertia is increased (less-favorable load coupling as discussed in section 2.3). The increased roll inertia caused a degradation in the mean HQR from 3.8 (case 160, SL5) to 4.4 (case 192, SL5). Configuration 160 received ratings as good as 2.5, whereas configuration 192 was rated 4.5 by three of four pilots and 4.0 by the fourth pilot, i.e., the increased roll inertia definitely degraded the handling qualities to Level 2.

This parameter variation was accomplished to isolate the moment-of-inertia effect, as the primary difference between the pitch and roll axes. Case 192 roll is seen to plot reasonably close to case 160 pitch in figure 16.

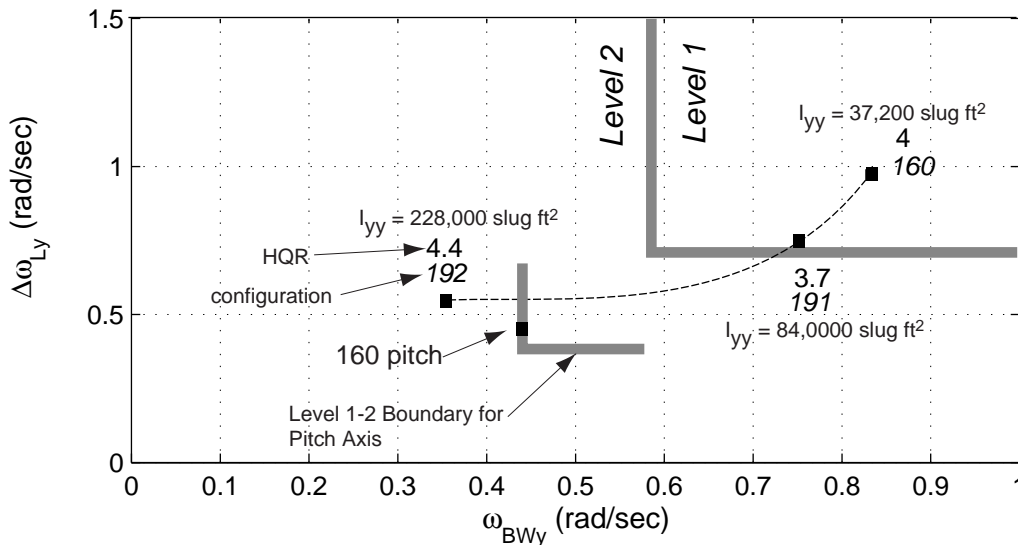

Figure 16. Effect of Roll Inertia.

3.8 Comparison of Longitudinal and Lateral Criteria Boundaries

The reason that the roll-axis boundaries are more stringent than those for the pitch axis is not completely understood. It is possible that the lateral task was more stringent than the longitudinal task for the precision hover because the hover cues for the test course (fig. C-4, appendix C) are somewhat more sensitive to lateral deviations than longitudinal

deviations. Another possibility is that it is normal for helicopters to have significantly higher pitch inertia than roll inertia so that the pilots expect a more sluggish response in pitch.

4 Results With Load Off

4.1 Pitch and Roll Bandwidth

Precision Hover Task – Load Off

Several configurations were tested with internal load only (load off). These all had the same total 46,000-lb weight as the external load configurations.

The attitude bandwidth for the load-off configurations is plotted vs. HQR in figure 17. The flight-control-system gains were adjusted so that the pitch and roll attitude bandwidths were equal for all load-off configurations.

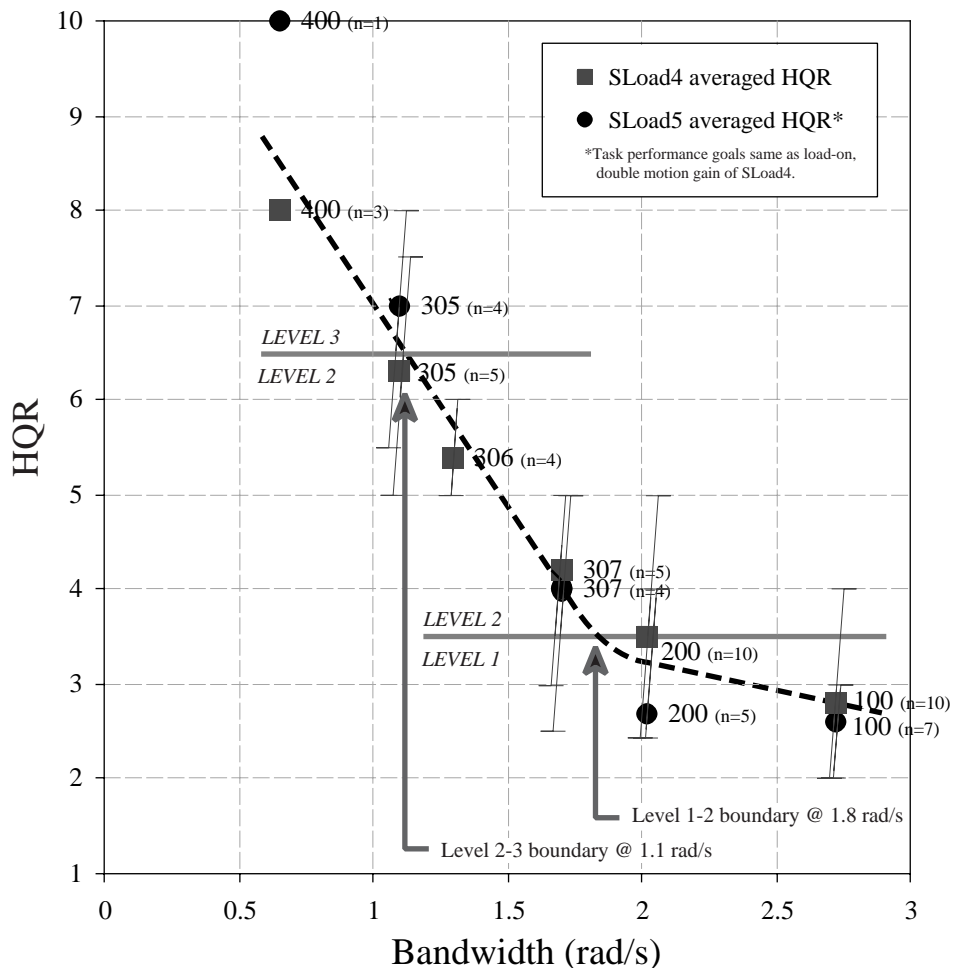

Figure 17. Pilot Ratings with Load Off – Precision Hover Task.

These data are in agreement with the low-speed and hover attitude-bandwidth boundary for Level 1-2 in ADS-33D ($UCE > 1$ and/or divided attention operations). That criterion requires that the pitch and roll bandwidths be greater than 2 rad/sec for Level 1 and 0.5 rad/sec for Level 2. The data in figure 17 indicate that the Level 2-3 bandwidth boundary should be increased to 1.0 rad/sec.

It is unlikely that the increase in the Level 2-3 bandwidth boundary can be attributed to factors that are unique to cargo helicopters. It is more likely that the ADS-33D boundary at 0.50 rad/sec is too low (for all types of helicopters). A review of the supporting data for the ADS-33D bandwidth criterion reveals that there are very few points to support the Level 2-3 boundary. On that basis, the Level 2-3 ADS-33E boundary for pitch and roll bandwidth in $UCE \geq 2$ and/or divided attentions operations has been increased from 0.50 to 1.0 rad/sec in ADS-33E.

Large-Amplitude Tasks – Load Off

The pilot rating data in figure 18 allow a comparison of the rating trends for the larger-amplitude tasks to the ratings obtained for precision hover. These results indicate that the pilot ratings for both the lateral-reposition and normal-departure abort-to-landing-zone tended to degrade slightly less rapidly than for the precision-hover task as the attitude bandwidth was reduced. This trend was also observed with load on (precision hover was the most critical task), as discussed in section 2.3.

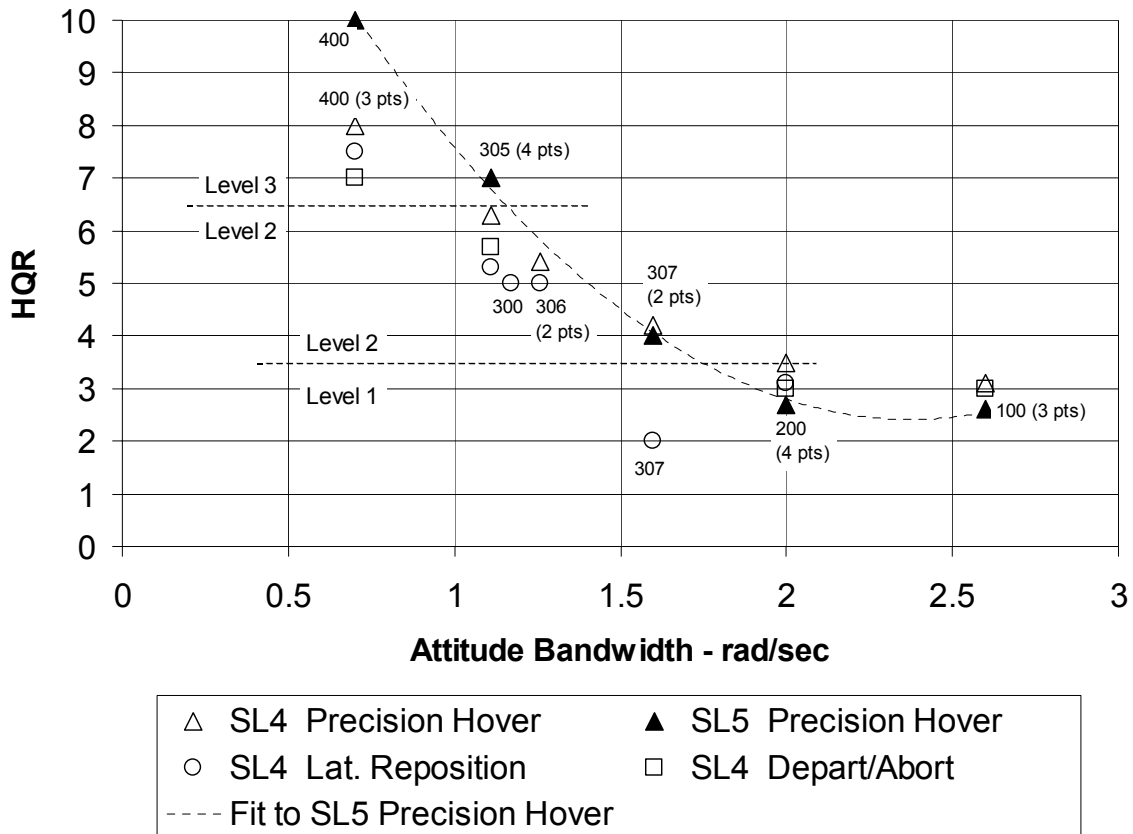

Figure 18. Effect of Bandwidth on Various Tasks.

4.2 Heading Bandwidth

The results of a brief experiment to investigate the effect of directional bandwidth for cargo helicopters with no external load are shown in figure 19. There was no evidence of Level 2 handling qualities in the pilot commentary or ratings until the bandwidth was decreased to less than 0.5 rad/sec. This is considerably less than required for scout/attack helicopters where the point-and-shoot tasks (target acquisition and tracking) drives the heading bandwidth requirement to 3.5 rad/sec. A search for a more critical task for cargo helicopters did not yield any more stringent requirements on heading bandwidth than illustrated in figure 19. The open symbols in figure 19 are for pilot Stortz, and the closed symbols are for pilot Wilson.

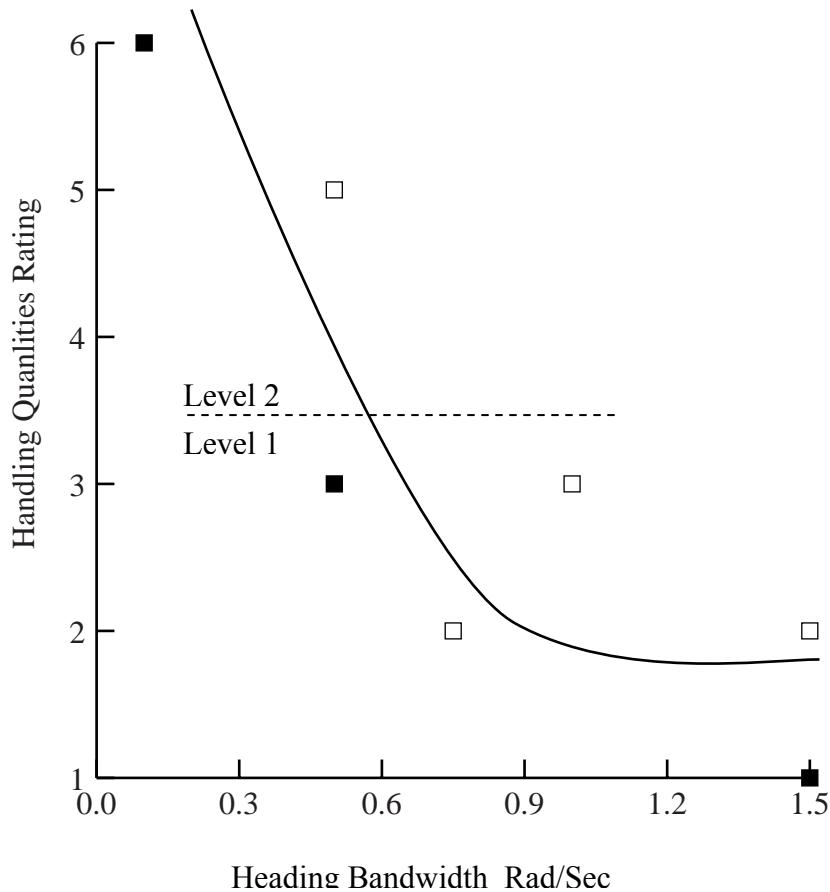

Figure 19. Effect of Bandwidth on Hovering Turn Task – Load Off.

5 Summary and Conclusions

Handling-qualities criteria have been developed for cargo helicopters carrying external slung loads in the DVE. If satisfied, these criteria provide assurance that the HQR will be 4 or better for operations in the DVE, and with a load-mass ratio of 0.33 or less. For lighter loads, flying qualities were found to be less dependent on the load geometry and therefore the significance of the criteria is less. For heavier loads, meeting the criteria

ensures the best possible handling qualities, albeit Level 2 for load-mass ratios greater than 0.33.

Because the task of carrying a heavy load in the DVE with precision is inherently high workload, the Level 1-2 boundary has been relaxed from a Cooper-Harper Handling Qualities Rating of 3.5 to 4.0.

Level 1 handling qualities in the DVE require a SAS that provides an ACAH+HH response type with no external load (see ADS-33D/E). These tests verified that this result applies to an even greater extent when carrying an external load. Therefore, the criteria developed herein ensure only Level 1 handling in the DVE if an ACAH + HH SAS is used.

Mission task elements (MTEs) were developed for cargo helicopters with and without external loads. These MTEs were incorporated into ADS-33E-PRF.

The quantitative criteria developed in this report are based solely on piloted simulation. Some flight-test verification is felt to be necessary before these criteria can be deemed sufficiently mature for inclusion into ADS-33. Until such verification can be accomplished, it is suggested that the quantitative criteria be used for design guidance.

The qualitative results of the report were incorporated into paragraph 3.1.5.2 “Assigned levels of handling qualities” by virtue of the following text. “With externally slung loads, the HQRs shall be Level 1 for load mass ratios less than 0.25 and shall not degrade to worse than 4.0 for load mass ratios up to 0.33. The government shall judge the acceptability of any degradations when performing a MTE in moderate wind, and with load mass ratios greater than 0.33.”

6 References

1. Anon: ADS-33D-PRF, Aeronautical Design Standard, Handling Qualities Requirements for Military Rotorcraft. United States Army Aviation and Troop Command, ADS-33D-PRF, May 10, 1996.
2. Anon: ADS-33E-PRF, Aeronautical Design Standard, Performance Specification, Handling Qualities Requirements for Military Rotorcraft. United States Army Aviation and Missile Command, Aviation Engineering Directorate, Redstone Arsenal, Alabama, March 21, 2000.
3. Hoh, Roger H.: Handling Qualities Criterion for Very Low Visibility Rotorcraft NOE Operations. AGARD CP 423, Amsterdam, October 1986.
4. Woratschek, Ralph, et al: Engineering Evaluation of the Cargo Helicopter Requirements of Aeronautical Design Standard 33C/D. ATCOM Project No. 93-02, U.S. Army Aviation Technical Test Center, Ft. Rucker, Alabama, May 1997.
5. Heffley, Robert K.: ROTORGEN Minimal-Complexity Simulator Math Model with Application to Cargo Helicopters (U). NASA CR-196705, March 1997.
6. Cicolani, Luigi S.; and Gerd Kanning: Equations of Motion of Slung-Load Systems, Including Multilift Systems. NASA TP 3280, November 1992.

7. Heffley, Robert K. and Marc A. Mnych, Minimum-Complexity Helicopter Simulation Math Model, NASA CR 177476, USAAVSCOM TR 87-A-7), April 1988.
8. Glauret, H., A General Theory of the Autogyro, RAE Reports and Memoranda No. 1111, November 1926.
9. Chen, Robert T. N., Effect of Primary Rotor Parameters on Flapping Dynamics, NASA Technical Paper 1431, January 1960.
10. Lamb, Horace, Hydrodynamics, New York, Dover Publications, 1946
11. McRuer, D.T. and E.S. Drendel, Mathematical Models of Human Pilot Behavior, AGARD – AG-188, January, 1974

Appendix A – Detailed Test Configurations

A.1 Simulated Helicopter

The math models used in the simulations and supporting analyses were based on the Boeing CH-47 tandem rotor airframe and propulsion system with weights and installed power representative of the CH-47D.

Engine power response was checked against flight-test measurements of the CH-47D, including lag in the cockpit indicator.

A.2 Internal and External Loadings

The combined mass of the aircraft plus load was held constant at 46,000 lb. This presented the pilot with a consistent trim condition and a clear view of the essential differences in dynamics between internal and external load configurations. The 46,000-lb gross weight represented a heavily loaded condition for the CH-47D and was the same as that used during prior flight tests of ADS-33 maneuvers at Edwards Air Force Base (ref. 4).

The internal load configuration consisted of a vehicle rigid body with a total mass of 46,000 lb and appropriate moments of inertia based on the CH-47D helicopter.

In most cases the load weight was 16,000 lb with a vehicle weight of 30,000 lb and a total gross weight of 46,000 lb. Configuration 290 represents an extreme external load of 27,600 lb and a vehicle weight of 18,400 lb to provide a total weight of 46,000 lb. All single-point loads have a hook position at the fuselage station coincident with the actual CH-47D. This station is also the location of the aircraft c.g.. Primary load geometry variables were vertical distance from c.g. to hook, d , and sling length, l .

A.3 Flight Control System

An ACAH response type was used in both pitch and roll axes. Loop gains for each axis were set to give equal bandwidths without the presence of an external load. Figure A-1 shows the SCAS architecture, including all the feedforward and feedback features. These features consist of a high-frequency prefilter, feedforward lag-lead shaping, command gain, loop gain, integral gain, and lead compensation.

A.4 Test Matrix

Table A-1 lists the configurations tested in terms of SCAS and load characteristics. The first seven configurations do not have an external load, but are the bases of all of the subsequent slung-load configurations in terms of SCAS configuration. For example, configuration 160 is a slung-load version of configuration 100, 16000 lb of the load shifted from an internal to an external configuration and with hook position 7 ft below the c.g., and a sling length of 20 ft (baseline external load used in this study).

Table A-1 Summary of Test Configurations

Configu- ration	SCAS Lag	SCAS Configuration		Load	Load Geometry			Load Weight	Attitude Bandwidth			Comments
	1/T ₂	Lat/Lon	Dir	Type	L	d	d2	Lat	Lon	Dir		
100		ACAH1	YAW0	None	-	-	-	-	2.60		1.50	High bandwidth (BW)
200		ACAH2	YAW0	None	-	-	-	-	2.02		1.50	Medium BW
201		ACAH2	YAW0	None					2.02		1.0	Vary heading BW
202		ACAH2	YAW0	None					2.02		0.75	Vary heading BW
203		ACAH2	YAW0	None					2.02		0.50	Vary heading BW
204		ACAH2	YAW0	None					2.02		0.10	Vary heading BW
300		ACAH3	YAW0	None	-	-	-	-	1.17		1.50	Low BW
305	0.87	ACAH3M	YAW0	None	-	-	-	-	1.11		1.50	Shaping to reduce BW
306	1	ACAH3M	YAW0	None	-	-	-	-	1.26		1.50	305 + CIA = CIE = 1.0
307	1.3	ACAH3M	YAW0	None	-	-	-	-	1.6		1.50	305 + CIA = CIE = 1.3
400	0.45	ACAH4	YAW0	None	-	-	-	-	0.70		1.50	Shaping to reduce BW
160		ACAH1	YAW0	1pt	20	7	-	16000	1.34		1.50	High BW Baseline
110		ACAH1	YAW0	1pt	31	7	-	16000	1.09		1.50	Vary sling length
120		ACAH1	YAW0	1pt	48	7	-	16000	0.89		1.50	Vary sling length
150		ACAH1	YAW0	1pt	50	7	-	16000	0.88		1.50	Vary sling length
130		ACAH1	YAW0	1pt	79	7	-	16000	0.70		1.50	Vary sling length
140		ACAH1	YAW0	1pt	150	7	-	16000	0.50		1.50	Vary sling length
155	1.6	ACAH1	YAW0	1pt	50	7	-	16000	0.86			Shaping to reduce BW
156	1.3	ACAH1	YAW0	1pt	50	7	-	16000	0.84			Shaping to reduce BW
165	1.6	ACAH1	YAW0	1pt	20	7	-	16000	1.27			Shaping to reduce BW
166	1.3	ACAH1	YAW0	1pt	20	7	-	16000	1.18			Shaping to reduce BW
189		ACAH1	YAW0	1pt	20	7		27600				Vary load weight
191		ACAH1	YAW0	1pt	20	7	-	16000				Iyy = 84000
192		ACAH1	YAW0	1pt	20	7		16000				Iyy = 228000
193		ACAH1	YAW0	1pt	20	7		8000				Vary load weight
195		ACAH1	YAW0	1pt	20	7		4000				Vary load weight
210		ACAH2	YAW0	1pt	20	7	-	16000	1.06		1.50	Medium BW Baseline
214		ACAH2	YAW0		20	5		16000				210 + d = 5 ft
215		ACAH2	YAW0		20	2		16000				210 + d = 5 ft
217		ACAH2	YAW0		20	0		16000				210 + d = 0 ft
220		ACAH2	YAW0	1pt	20	14	-	16000	0.85		1.50	210 + d = 14 ft
230		ACAH2	YAW0	1pt	20	21	-	16000	0.70		1.50	210 + d = 27 ft'
240		ACAH2	YAW0	1pt	54	7	-	16000	0.70		1.50	
290		ACAH2	YAW0	1pt	29	7	-	27600	1.23		1.50	Vary load weight

Configu- ration	SCAS Lag	SCAS Configuration.		Load Type	Load Geometry			Load Weight	Attitude Bandwidth			Comments
		1/T ₂	Lat/Lon		Dir	L	d		d2	Lat	Lon	
293		ACAH2	YAW0	1pt	20	7		8000				Vary load weight
294		ACAH2	YAW0	1pt	20	7		12000				Vary load weight
295		ACAH2	YAW0	1pt	20	7		4000				Vary load weight
310		ACAH3	YAW0	1pt	15	2	-	16000	1.09		1.50	
320		ACAH3	YAW0	1pt	8	7	-	16000	0.90		1.50	
330		ACAH3	YAW0	1pt	20	7	-	16000	0.69		1.50	
325		ACAH3M	YAW0	1pt	31	7		16000			1.50	
335		ACAH3M	YAW0	1pt	68	7		16000			1.50	

Appendix B – Detailed Pilot Ratings and Commentary

B.1 Cooper-Harper Handling-Qualities Results

Table B-1. Cooper-Harper HQRs from SL4 Experiment

Run	Task	Configuration	Load	Pilot	HQR	n	Average	rms	
074	Precision hover	110	L = 31	Stortz	3				
125	Precision hover	110	L = 31	Stortz	3				
348	Precision hover	110	L = 31	Tucker	3				
1336	Precision hover	110	L = 31	Dunn	3		+		
1122	Precision hover	110	L = 31	Dunn	4.5	5	3.3	±0.7	<i>Config 110</i>
1085	Precision hover	110*	L = 31	Dunn	4				
1010	Precision hover	110*	L = 31	Gerdes	3				
1102	Precision hover	110*	L = 31	Stortz	2				
1024	Precision hover	110*	L = 31	Tucker	5				
648	Precision hover	110*	L = 31	Wilson	3	5	3.4	±1.1	<i>Config 110*</i>
120	Precision hover	120	L = 48	Stortz	5				
1151	Precision hover	120	L = 48	Stortz	3				
351	Precision hover	120	L = 48	Tucker	2				
1464	Precision hover	120		Gerdes	3	4	3.3	±1.3	<i>Config 120</i>
651	Precision hover	120*	L = 48	Wilson	3				
1014	Precision hover	130	L = 79	Gerdes	4				
096	Precision hover	130	L = 79	Stortz	5				
355	Precision hover	130	L = 79	Tucker	3	3	4.0	±1.0	<i>Config 130</i>
655	Precision hover	130*	L = 79	Wilson	4				
1092	Precision hover	140*	L = 150	Dunn	4				
1017	Precision hover	140*	L = 150	Gerdes	4.5				
695	Precision hover	140*	L = 150	Tucker	5				
1028	Precision hover	140*	L = 150	Tucker	5				
663	Precision hover	140*	L = 150	Wilson	5	5	4.7	±0.4	<i>Config 140*</i>
629	Precision hover	150	L = 50	Stortz	5				
344	Precision hover	150	L = 50	Tucker	3				
954	Precision hover	150*	L = 50	Gerdes	3				
625	Precision hover	150*	L = 50	Stortz	4				

Run	Task	Configuration	Load	Pilot	HQR	n	Average	rms	
700	Precision hover	150*	L = 50	Stortz	5				
685	Precision hover	150*	L = 50	Tucker	4				
635	Precision hover	150*	L = 50	Wilson	3	7	3.9	±0.8	<i>Config 150</i>
622	Precision hover	155	L = 50	Stortz	5				
710	Precision hover	155	L = 50	Stortz	5				
692	Precision hover	155	L = 50	Tucker	5				
639	Precision hover	155	L = 50	Wilson	4.5	4	4.9	±1.5	<i>Config 155</i>
632	Precision hover	156	L = 50	Stortz	8				
713	Precision hover	156	L = 50	Stortz	7				
688	Precision hover	156	L = 50	Tucker	8				
642	Precision hover	156	L = 50	Wilson	5	4	7.0	±1.4	<i>Config 156</i>
645	Precision hover	157	L = 50	Wilson	7				
1087	Precision hover	160*	L = 20	Dunn	4				
942	Precision hover	160*	L = 20	Gerdes	3				
1007	Precision hover	160*	L = 20	Gerdes	4				
962	Precision hover	160*	L = 20	Stortz	5				
974	Precision hover	160*	L = 20	Stortz	5				
987	Precision hover	160*	L = 20	Tucker	4				
1032	Precision hover	160*	L = 20	Tucker	4.5				
1323	Precision hover	160	L = 20	Dunn	4				
1048	Precision hover	160	L = 20	Stortz	4				
999	Precision hover	160	L = 20	Tucker	4				
1690	Precision hover	160	L = 20	Tucker	5				
1467	Precision hover	160	L = 20	Gerdes	4	12	4.2	±0.6	<i>Config 160</i>
951	Precision hover	165	L = 20	Gerdes	4				
970	Precision hover	165	L = 20	Stortz	6				
1002	Precision hover	165	L = 20	Tucker	4	3	4.7	±1.2	<i>Config 165</i>
948	Precision hover	166	L = 20	Gerdes	7				
965	Precision hover	166	L = 20	Stortz	7				
1326	Precision hover	166	L = 20	Dunn	6				
1471	Precision hover	166	L = 20	Gerdes	5.5	4	6.4	±1.1	<i>Config 166</i>
1063	Precision hover	200	off	Dunn	4				
1066	Precision hover	200	off	Dunn	3				
031	Precision hover	200	off	Gerdes	4				
015	Precision hover	200	off	Stortz	3				

Run	Task	Configuration	Load	Pilot	HQR	n	Average	rms	
1133	Precision hover	200	off	Stortz	3				
1136	Precision hover	200	off	Stortz	3				
062	Precision hover	200	off	Tucker	5				
1608	Precision hover	200	off	Tucker	2.5				
322	Precision hover	200	off	Wilson	3				
577	Precision hover	200	off	Wilson	4	10	3.5	±0.8	<i>Config 200</i>
1461	Precision hover	200*	off	Gerdes	3				
1528	Precision hover	200*	off	Tucker	4				
1591	Precision hover	200*	off	Tucker	3	13	3.4	±0.7	<i>Config 200*</i>
1075	Precision hover	210	std	Dunn	3				
034	Precision hover	210	std	Gerdes	3				
051	Precision hover	210	std	Stortz	2				
083	Precision hover	210	std	Stortz	3				
1044	Precision hover	210	std	Stortz	2				
1524	Precision hover	210	std	Stortz	3				
1554	Precision hover	210	std	Stortz	4				
107	Precision hover	210	std	Tucker	3				
996	Precision hover	210	std	Tucker	2				
326	Precision hover	210	std	Wilson	3				
570	Precision hover	210	std	Wilson	5				
581	Precision hover	210	std	Wilson	3				
1097	Precision hover	210*	std	Dunn	5				
595	Precision hover	210*	std	Gerdes	4				
1041	Precision hover	210*	std	Stortz	5				
1147	Precision hover	210*	std	Stortz	4				
1551	Precision hover	213	std	Stortz	5				
993	Precision hover	210*	std	Tucker	4				
586	Precision hover	210*	std	Wilson	4	19	3.5	±1.0	<i>Config 210</i>
600	Precision hover	214	d = 5'	Gerdes	4.5				
1485	Precision hover	214	d = 5'	Stortz	4				
1601	Precision hover	214	d = 5'	Tucker	5	3	4.5	±0.5	<i>Config 214</i>
603	Precision hover	215	d = 2'	Gerdes	6				
1498	Precision hover	215	d = 2'	Gerdes	5				
590	Precision hover	215	d = 2'	Wilson	5				
1489	Precision hover	215	d = 2'	Stortz	6				
1509	Precision hover	215	d = 2'	Stortz	6				
1605	Precision hover	215	d = 3'	Tucker	6	6	5.7	±0.5	<i>Config 215</i>
041	Precision hover	220	d = 14	Gerdes	5				

Run	Task	Configuration	Load	Pilot	HQR	n	Average	rms	
329	Precision hover	220	d = 14	Wilson	2				
1116	Precision hover	220	d = 14	Dunn	3				
1119	Precision hover	220	d = 14	Dunn	4				
1155	Precision hover	220	d = 14	Dunn	4				
1140	Precision hover	220	d = 14	Stortz	5				
1541	Precision hover	220	d = 14	Tucker	5				
608	Precision hover	220*	d = 14	Gerdes	4.5	8	4.1	±1.1	<i>Config 220</i>
045	Precision hover	230	d = 21	Gerdes	8				
055	Precision hover	230	d = 21	Stortz	4				
079	Precision hover	230	d = 21	Stortz	5				
091	Precision hover	230	d = 21	Stortz	2				
115	Precision hover	230	d = 21	Tucker	7.5				
332	Precision hover	230	d = 21	Wilson	4				
1127	Precision hover	230	d = 21	Dunn	5.5	7	5.1	±2.1	<i>Config 230</i>
048	Precision hover	240	L = 54	Gerdes	7				
1054	Precision hover	240	L = 54	Stortz	5				
111	Precision hover	240	L = 54	Tucker	3				
335	Precision hover	240	L = 54	Wilson	4				
1130	Precision hover	240	L = 54	Dunn	3				
1036	Precision hover	240*	L = 54	Tucker	5	6	4.5	±1.5	<i>Config 240</i>
1320	Precision hover	290	L = 7	Dunn	5.5				
1143	Precision hover	290	L = 7	Stortz	5				
1475	Precision hover	290	L = 7	Gerdes	6				
1694	Precision hover	290	L = 7	Tucker	5.5	4	5.5	±0.4	<i>Config 290</i>
1078	Precision hover	305	off	Dunn	6				
1020	Precision hover	305	off	Gerdes	7				
021	Precision hover	305	off	Stortz	5				
359	Precision hover	305	off	Tucker	7.5				
666	Precision hover	305	off	Wilson	6	5	6.3	±1.0	<i>Config 305</i>
1349	Precision hover	306	off	Dunn	5				
1504	Precision hover	306	off	Gerdes	5				
1516	Precision hover	306	off	Stortz	6				
1537	Precision hover	306	off	Tucker	5.5	4	5.4	±0.5	<i>Config 306</i>
1352	Precision hover	307	off	Dunn	3				
1506	Precision hover	307	off	Gerdes	3				
1520	Precision hover	307	off	Stortz	5				

Run	Task	Configuration	Load	Pilot	HQR	n	Average	rms	
1532	Precision hover	307	off	Tucker	5				
1665	Precision hover	307	off	Tucker	5	5	4.2	±1.1	<i>Config 307</i>
025	Precision hover	400	off	Stortz	8				
070	Precision hover	400	off	Tucker	8				
669	Precision hover	400	off	Wilson	8	3	8.0	±0.0	<i>Config 400</i>
234	Lateral reposition	100	off	Stortz	2				
377	Lateral reposition	100	off	Gerdes	5				
391	Lateral reposition	100	off	Wilson	3				
462	Lateral reposition	100	off	Gerdes	2.5				
1648	Lateral reposition	100	off	Tucker	3	5	3.1	±1.1	<i>Config 100</i>
226	Lateral reposition	110	on	Tucker	2				
398	Lateral reposition	110	on	Wilson	4				
416	Lateral reposition	110	on	Stortz	3				
1619	Normal Dep/Abt	110	on	Stortz	4	4	3.3	±0.4	<i>Config 110</i>
295	Lateral reposition	120	on	Tucker	5				
395	Lateral reposition	120	on	Wilson	4				
432	Lateral reposition	120	on	Stortz	4				
203	Lateral reposition	130	on	Wilson	4				
211	Lateral reposition	130	on	Tucker	4				
425	Lateral reposition	130	on	Stortz	5				
1654	Lateral reposition	140	on	Tucker	3				
222	Lateral reposition	150	on	Tucker	2.5				
402	Lateral reposition	150	on	Wilson	3				
468	Lateral reposition	150	on	Gerdes	5				
503	Lateral reposition	150	on	Stortz	3				
542	Lateral reposition	150	on	Stortz	?	4	3.4	±1.1	<i>Config 150</i>
478	Lateral reposition	155	on	Wilson	3				
493	Lateral reposition	155	on	Stortz	3				
482	Lateral reposition	156	on	Wilson	7				
487	Lateral reposition	156	on	Stortz	6				
1651	Lateral reposition	160	on	Tucker	2				
1686	Lateral reposition	160	on	Tucker	2				

Run	Task	Configuration	Load	Pilot	HQR	n	Average	rms	
161	Lateral reposition	200	off	Tucker	2.5				
184	Lateral reposition	200	off	Wilson	4				
230	Lateral reposition	200	off	Stortz	2				
259	Lateral reposition	200	off	Wilson	3				
367	Lateral reposition	200	off	Gerdes	3				
383	Lateral reposition	200	off	Gerdes	6				
386	Lateral reposition	200	off	Wilson	3				
412	Lateral reposition	200	off	Stortz	2				
438	Lateral reposition	200	off	Wilson	2	9	3.1	±1.3	<i>Config 200</i>
459	Lateral reposition	205	off	Wilson	6				
166	Lateral reposition	210	std	Tucker	2				
189	Lateral reposition	210	std	Wilson	4				
244	Lateral reposition	210	std	Stortz	3				
267	Lateral reposition	210	std	Wilson	3				
371	Lateral reposition	210	std	Gerdes	?				
471	Lateral reposition	210	std	Gerdes	4				
533	Lateral reposition	210	std	Stortz	5				
554	Lateral reposition	210	std	Wilson	4				
537	Lateral reposition	212	d = 5'	Stortz	4				
516	Lateral reposition	213	d = 4'	Wilson	3				
522	Lateral reposition	215	d = 2'	Wilson	3				
528	Lateral reposition	217	d = 0'	Wilson	6				
563	Lateral reposition	217	d = 0'	Wilson	4.5				
251	Lateral reposition	220	d = 14	Stortz	5				
263	Lateral reposition	220	d = 14	Wilson	4				
277	Lateral reposition	220	d = 14	Tucker	6				
178	Lateral reposition	230	d = 21	Tucker	4				
195	Lateral reposition	230	d = 21	Wilson	7				
547	Lateral reposition	230	d = 21	Stortz	7				
1671	Lateral reposition	230	d = 21	Tucker	6				
172	Lateral reposition	240	l = 54	Tucker	3				
1676	Lateral reposition	240	l = 54	Tucker	4				
192	Lateral reposition	240	l = 54	Wilson	4.5				
217	Lateral reposition	290	WL = 27,600	Tucker	3				
271	Lateral reposition	290	WL =	Wilson	4				

Run	Task	Configuration	Load	Pilot	HQR	n	Average	rms	
			27,600						
298	Lateral reposition	290	WL = 27,600	Tucker	2				
444	Lateral reposition	300	off	Wilson	5				
240	Lateral reposition	305	off	Stortz	6				
285	Lateral reposition	305	off	Tucker	6				
309	Lateral reposition	305	off	Wilson	4				
1658	Lateral reposition	306	off	Tucker	5				
1661	Lateral reposition	307	off	Tucker	2				
496	Lateral reposition	330	std	Stortz	7				
302	Lateral reposition	335	L = 68	Tucker	7				
404	Lateral reposition	335	L = 68	Wilson	9				
449	Lateral reposition	400	off	Wilson	7				
1683	Lateral reposition	400	off	Tucker	8				
775	Normal Dep/Abt	100	off	Stortz	?				
881	Normal Dep/Abt	100	off	Stortz	3				
806	Normal Dep/Abt	100	off	Wilson	3				
1255	Normal Dep/Abt	100	off	Dunn	3				
1237	Normal Dep/Abt	110	on	Dunn	4				
832	Normal Dep/Abt	110*	on	Wilson	3				
824	Normal Dep/Abt	120*	on	Wilson	3				
902	Normal Dep/Abt	130*	on	Stortz	4				
866	Normal Dep/Abt	130*	on	Wilson	4				
1229	Normal Dep/Abt	140	on	Stortz	5				
1298	Normal Dep/Abt	140	on	Dunn	2				
869	Normal Dep/Abt	140*	on	Wilson	3				
790	Normal Dep/Abt	150*	on	Stortz	?				
896	Normal Dep/Abt	150*	on	Stortz	3				
817	Normal Dep/Abt	150*	on	Wilson	4.5				
845	Normal Dep/Abt	150*	on	Wilson	3				
916	Normal Dep/Abt	155	on	Wilson	4.5				

Run	Task	Configuration	Load	Pilot	HQR	n	Average	rms	
910	Normal Dep/Abt	156	on	Stortz	5				
841	Normal Dep/Abt	156	on	Wilson	5				
848	Normal Dep/Abt	157	on	Wilson	7				
1233	Normal Dep/Abt	160	on	Dunn	4				
1217	Normal Dep/Abt	160	on	Stortz	3				
1260	Normal Dep/Abt	165	on	Dunn	4.5				
1627	Normal Dep/Abt	165	on	Stortz	5				
1295	Normal Dep/Abt	166	on	Dunn	3				
1264	Normal Dep/Abt	166	on	Dunn	6				
1222	Normal Dep/Abt	166	on	Stortz	5				
1271	Normal Dep/Abt	168	on	Dunn	5				
1288	Normal Dep/Abt	169	on	Dunn	3				
1276	Normal Dep/Abt	170	on	Dunn	4				
1291	Normal Dep/Abt	170	on	Dunn	4				
1201	Normal Dep/Abt	200	off	Stortz	2				
1184	Normal Dep/Abt	200	off	Dunn	3				
812	Normal Dep/Abt	200*	off	Wilson	3				
884	Normal Dep/Abt	200*	off	Stortz	3				
1192	Normal Dep/Abt	210	on	Dunn	3				
1208	Normal Dep/Abt	210	on	Stortz	3				
873	Normal Dep/Abt	210*	off	Wilson	4				
1308	Normal Dep/Abt	211	off	Dunn	3				
1312	Normal Dep/Abt	212	off	Dunn	2				
922	Normal Dep/Abt	220	on	Wilson	4				
1633	Normal Dep/Abt	220	on	Stortz	6				
926	Normal Dep/Abt	230	on	Wilson	4.5				
1213	Normal Dep/Abt	230	on	Stortz	5				
930	Normal Dep/Abt	240	on	Wilson	3				
1639	Normal Dep/Abt	240	on	Stortz	5				

Run	Task	Configuration	Load	Pilot	HQR	n	Average	rms	
878	Normal Dep/Abt	290	on	Wilson	4				
1302	Normal Dep/Abt	290	on	Dunn	3				
1644	Normal Dep/Abt	290	on	Stortz	4				
1241	Normal Dep/Abt	305	off	Dunn	6				
889	Normal Dep/Abt	305	off	Stortz	6				
856	Normal Dep/Abt	305	off	Wilson	5				
933	Normal Dep/Abt	320	on	Wilson	6				
892	Normal Dep/Abt	400	off	Stortz	8				
860	Normal Dep/Abt	400	off	Wilson	7				
1244	Normal Dep/Abt	400	off	Dunn	9				
1188	Accel/Decel	200	off		3				
613	Hover turn	200	off	Wilson	1				
1104	Hover turn	200	off	Stortz	2				
1105	Hover turn	201	off	Stortz	3				
615	Hover turn	203	Wbw = 0.5	Wilson	3				
1107	Hover turn	203	off	Stortz	5				
1108	Hover turn	202	off	Stortz	2				
617	Hover turn	204	Wbw = 0.1	Wilson	6				
1569	Hover turn	281	2 pt	Stortz	3				
1572	Hover turn	282	2 pt	Stortz	3				
1574	Hover turn	203	off	Stortz	2				
1578	Hover turn	203*	off	Stortz	4				
1582	Hover turn	283	2 pt	Stortz	4				
1584	Hover turn	284	2 pt	Stortz	10				
1587	Hover turn	285	2 pt	Stortz	5				

* Denotes that pitch moment inertia was slightly off nominal. Nominal was 250,000 slug-ft² and starred cases were 228,000 slug-ft².

Table B-2. Cooper-Harper HQRs from SL5 Experiment - Precision Hover Task

Run	Configuration	Load	Pilot	HQR	n	Average	rms	
665	100	No load	Gerdes	2.5				
831	100	No load	Gerdes	3				
815	100	No load	Simmons	3				
713	100	No load	Sullivan	2				
696	100	No load	Wilson	2.5				
758	100	No load	Wilson	2.5				
849	100	No load	Wilson	2.5	7	2.6	±0.3	<i>Config 100</i>
513	110	L = 31' WL = 16K	Simmons	4				
481	110	L = 31' WL = 16K	Wells D	4.5	2	4.3	±0.4	<i>Config 110</i>
517	120	L = 48' WL = 16K	Simmons	3				
638	120	L = 48' WL = 16K	Sullivan	3				
532	120	L = 48' WL = 16K	Wells D	6	3	4.0	±1.7	<i>Config 120</i>
558	130	L = 79' WL = 16K	Simmons	4.5				
718	130	L = 79' WL = 16K	Sullivan	4				
735	130	L = 79' WL = 16K	Wilson	4				
539	130	L = 79' WL = 16K	Wells D	6	4	4.6	±0.9	<i>Config 130</i>
647	140	L = 150' WL = 16K	Sullivan	4				
677	140	L = 150' WL = 16K	Gerdes	4				
661	140	L = 150' WL = 16K	Wilson	4.5	3	4.2	±0.3	<i>Config 140</i>
4	160	L = 20' WL = 16K	Gerdes	4.5				
15	160	L = 20' WL = 16K	Gerdes	4.5				
233	160	L = 20' WL = 16K	Gerdes	3				
240	160	L = 20' WL = 16K	Gerdes	4.5				
360	160	L = 20' WL = 16K	Gerdes	4				
130	160	L = 20' WL = 16K	Simmons	3				
188	160	L = 20' WL = 16K	Simmons	5				
196	160	L = 20' WL = 16K	Simmons	4				
309	160	L = 20' WL = 16K	Simmons	4				
331	160	L = 20' WL = 16K	Sullivan	4				
658	160	L = 20' WL = 16K	Wilson	4				
853	160	L = 20' WL = 16K	Wilson	4				
872	160	L = 20' WL = 16K	Wilson	3				

Run	Configuration	Load	Pilot	HQR	n	Average	rms	
177	160	L = 20' WL = 16K	Wells D	3				
224	160	L = 20' WL = 16K	Wells D	2.5				
259	160	L = 20' WL = 16K	Wells D	4.5	16	3.8	±0.7	<i>Config 160</i>
730	189	L = 20' WL = 27.6K	Sullivan	5				
762	189	L = 20' WL = 27.6K	Wilson	6				
877	189	L = 20' WL = 27.6K	Wilson	5	3	5.3	±0.6	<i>Config 189</i>
368	191	L = 20' WL = 16K	Gerdes	4				
525	191	L = 20' WL = 16K	Simmons	4				
380	191	L = 20' WL = 16K	Wells D	3	3	3.7	±0.6	<i>Config 191</i>
12	192	L = 20' WL = 16K	Gerdes	4.5				
371	192	L = 20' WL = 16K	Gerdes	4				
521	192	L = 20' WL = 16K	Simmons	4.5				
388	192	L = 20' WL = 16K	Wells	4.5	4	4.4	±0.3	<i>Config 192</i>
362	193	L = 20' WL = 8K	Gerdes	3				
299	193	L = 20' WL = 8K	Simmons	3				
306	193	L = 20' WL = 8K	Simmons	3				
700	193	L = 20' WL = 8K	Wilson	3				
253	193	L = 20' WL = 8K	Wells D	4	5	3.2	±0.4	<i>Config 193</i>
365	195	L = 20' WL = 4K	Gerdes	2.5				
668	195	L = 20' WL = 4K	Gerdes	3				
302	195	L = 20' WL = 4K	Simmons	2				
248	195	L = 20' WL = 4K	Wells D	2	4	2.4	±0.5	<i>Config 195</i>
590	200	No load	Sullivan	2				
745	200	No load	Wilson	2.5				
341	200	No load	Wells D	4				
453	200	No load	Wells D	2				
500	200	No load	Wells D	3	5	2.7	±0.8	<i>Config 200</i>
9	210	L = 20' WL = 16K	Gerdes	4				
230	210	L = 20' WL = 16K	Gerdes	4				
236	210	L = 20' WL = 16K	Gerdes	4				
466	210	L = 20' WL = 16K	Gerdes	4.5				

Run	Configuration	Load	Pilot	HQR	n	Average	rms	
671	210	L = 20' WL = 16K	Gerdes	4				
134	210	L = 20' WL = 16K	Simmons	5				
183	210	L = 20' WL = 16K	Simmons	5				
192	210	L = 20' WL = 16K	Simmons	3				
313	210	L = 20' WL = 16K	Simmons	4.5				
424	210	L = 20' WL = 16K	Simmons	6				
427	210	L = 20' WL = 16K	Simmons	6				
819	210	L = 20' WL = 16K	Simmons	5				
322	210	L = 20' WL = 16K	Sullivan	3				
653	210	L = 20' WL = 16K	Wilson	4				
793	210	L = 20' WL = 16K	Wilson	4.5				
163	210	L = 20' WL = 16K	Wells D	4				
210	210	L = 20' WL = 16K	Wells D	3				
294	210	L = 20' WL = 16K	Wells D	5				
400	210	L = 20' WL = 16K	Wells D	4.5				
445	210	L = 20' WL = 16K	Wells D	4	20	4.4	±0.8	Config 210
674	210*	L = 20' WL = 16K	Gerdes	4	1	4.0		Config 210*
766	214	L = 20' WL = 16K	Wilson	5	1	5.0		Config 214
823	215	L = 20' WL = 16K	Simmons	6				
769	215	L = 20' WL = 16K	Wilson	5				
797	215	L = 20' WL = 16K	Wilson	5	3	5.3	±0.6	Config 215
827	217	L = 20' WL = 16K	Simmons	7				
800	217	L = 20' WL = 16K	Wilson	6	2	6.5	±0.7	Config 217
805	220	L = 20' WL = 16K	Wilson	4	1	4.0		Config 220
809	230	L = 20' WL = 16K	Wilson	4.5	1	4.5		Config 230
724	290	L=20' WL=27.6K	Sullivan	6				
704	290	L=20' WL=27.6K	Wilson	5	2	5.5	±0.7	Config 290
469	293	L = 20' WL = 8K	Gerdes	3				
582	293	L = 20' WL = 8K	Gerdes	3				
431	293	L = 20' WL = 8K	Simmons	4				

Run	Configuration	Load	Pilot	HQR	n	Average	rms	
602	293	L = 20' WL = 8K	Sullivan	3				
409	293	L = 20' WL = 8K	Wells D	2.5				
493	293	L = 20' WL = 8K	Wells D	4	6	3.3	±0.6	<i>Config 293</i>
472	294	L = 20' WL = 12K	Gerdes	4				
631	294	L = 20' WL = 12K	Sullivan	4				
419	294	L = 20' WL = 12K	Wells	3	3	3.7	±0.6	<i>Config 294</i>
586	295	L = 20' WL = 4K	Gerdes	3				
435	295	L = 20' WL = 4K	Simmons	4				
596	295	L = 20' WL = 4K	Sullivan	4				
607	295	L = 20' WL = 4K	Sullivan	2	4	3.3	±1.0	<i>Config 295</i>
865	302	L = 20' WL = 2K	Wilson	3	1	3.0		<i>Config 302</i>
835	307	No load	Gerdes	4				
740	307	No load	Wilson	5				
461	307	No load	Wells	2.5				
350	307	No load	Wells D	4.5	4	4.0	±1.1	<i>Config 307</i>
881	390	L = 20' WL = 28K	Wilson	5				
885	390	L = 20' WL = 28K	Wilson	5	2	5.0	±0.0	<i>Config 390</i>
567	305	No load	Simmons	7.5				
749	305	No load	Wilson	5.5				
355	305	No load	Wells D	8				
507	305	No load	Wells D	7	4	7.0	±1.1	<i>Config 305</i>
577	400	No load	Wells D	10	1	###		<i>Config 400</i>
267	160F	No motion	Wells D	6				
283	160F	No motion	Wells D	7	2	6.5	±0.7	<i>Config 160F</i>
475	210F	No motion	Gerdes	4.5				
275	210F	No motion	Wells D	7	2	5.8	±1.8	<i>Config 210F</i>

B.2 Pilot Commentary

This section presents excerpts from the pilot commentary. Only commentary related to the precision hover task are presented, since those were used to support the criteria in this report. Commentary from both the SL4 and SL5 simulations are presented. The primary difference between these simulations was that the motion gains were considerably higher in SL5 than in SL4. Also, SL5 focused entirely on the precision hover task, whereas SL4 included the lateral-reposition and normal departure/abort-to-landing zone tasks.

Each excerpted set of pilot comments is preceded by a header that identifies the configuration, pilot, and first run number. The excerpted commentaries are based on a series of runs that always included at least three runs. The experimental protocol called for the pilot to make at least three runs, and more if he felt that was desirable to achieve an opinion. The pilot then answered each of the questions on the following questionnaire, one of which required a Cooper Harper Handling Qualities Rating (HQR) for the task.

PILOT QUESTIONNAIRE FOR IMPROVED CARGO HELICOPTER SIMULATION

1. Were pitch, roll, and yaw attitude responses to control inputs predictable?
2. Were position and velocity responses to attitude changes predictable?
3. Did undesirable oscillations occur? If so, did the oscillations seem to be aggravated by the external load?
4. If trying for desired performance resulted in unacceptable oscillations, did decreasing your goal to adequate performance alleviate the problem?
5. If applicable, describe any unique pilot technique that you found necessary to accomplish the task.
6. Did motion cueing seem reasonable? Any tendency for disorientation, vertigo, or feeling of malaise due to motion?
7. Assign HQR, then answer following questions.
8. For cases with external load, did the load have a significant impact on the assigned HQR?
9. *If assigned HQR is Level 2*, briefly summarize the deficiencies that make this configuration unsuitable for normal accomplishment of this task.⁹
10. *If assigned HQR is Level 3*, briefly summarize the deficiencies that makes this configuration unsuitable to accomplish this task following a flight control system failure.¹⁰

⁹ Justify why procuring activity should reject this configuration as a means to accomplish this task.

¹⁰ Justify why procuring activity should reject this configuration as means to complete this task in the face of a flight control system failure.

The comments that were selected for publication were judged to be relevant to support of the handling qualities criteria developed in this report. In a few cases, a section of commentary is printed in bold to indicate a particularly important point.

The excerpted commentary are more extensive for configurations that played a primary role in the development of the criteria, or where it was desirable to show differences of opinion between pilots for the same configuration.

References to question numbers in the commentary refer to the above questionnaire.

CONFIG 110 – SL5

Pilot: Simmons

Run 508

I would say for the roll and pitch attitude response to control inputs was very precise and predictable. Almost too snappy, though. Velocity response to attitude was predictable. Position response to attitude, probably a little bit less so in that the control system seemed a little aggressive for the mission, to me. I don't know, if I tried for precise control I started aggravating the situation, a little bit too jerky, it seemed to me.

Undesirable oscillations occur? I wouldn't really say that I had oscillations. And the load is not as significant here as some other ones we have had.

I tried several different techniques here. I found that if I was smooth and slow on the inputs, that in this case it resulted in a pretty smooth response. I still had some shifting in position, so it did require me to stay in the loop for position hold. But if I tried to get aggressive and hold position, it felt pretty jerky, and so I didn't like that response. HQR = 4.

CONFIG 120 – SL4

Pilot: Stortz

Run 120

Pitch and roll response is good and predictable. That leads to predictable position or velocity responses for the helicopter. The load feels to me like it's on a long, it's a long sling, it's got a low period and its affect on the helicopter is to really jerk it around when I'm trying to stabilize it. The load does stabilize in what appears to be something like three or four oscillations. So not too objectionable from that point. And then once the load oscillations die down, then keeping it in the desired box is a piece of cake. So that kind of answers question 3.

I'm anticipating the start of the decel sooner, trying to do that smoothly and in plane or in the direction of my initial vector, I want to be careful not to excite the load too much in any other axis than that which I'm traveling in.

The effect of the oscillations are large, and moves the helicopter considerably. That oscillation and its effect on the helicopter is moderately objectionable. I am able to achieve desired performance, the vast majority of the time.

I'd call it moderate compensation, so the word descriptors are consistent with an HQR 4 but the load oscillation and its effect are moderately objectionable, therefore I'm rating it HQR 5.

CONFIG 120 – SL4

Pilot: Tucker

Run 351

Generally speaking, again very good performance, very predictable. Very nice deceleration, ability to go in there and get close, smooth the side flare and just drop it level, be pretty much on. So obviously **with an abrupt input it actually changes character quite a bit**. But the task as you have set it up can be flown with desired performance quite easily.. I would go with a 2. End of comments.

CONFIG 120 – SL5

Pilot: Sullivan

Run 638

The next question is position and velocity responses to attitude changes predictable? I really liked the roll axis of this one for maintaining position, I was able to move the aircraft laterally with really good precision, you know, once I was stable over the point I was able to move it probably less than a foot or so to get perfect alignment on the target. And I haven't been able to do that in all the other configurations. This one was really nice, in roll.

The pitch axis was somewhat less predictable, but still I would say predictable in both position and velocity with attitude changes.

Did undesirable oscillations occur? Yeah. Mainly in the pitch axis, again, like I said, roll was, roll was real nice, I thought.

And if so, did the oscillations seem to be aggravated by the external load? Yeah, definitely caused by that during the decels. I could feel the load moving around. I could feel the load moving around quite a bit in this configuration, but I was able to compensate for that and even though there were oscillations, they damped out. And I think I started out with just adequate performance, but by, I think the third run, I was consistently on the desired performance. HQR=3.

CONFIG 120 – SL5

Pilot: Simmons

Run 514

Generally this is kind of one of those configurations that there's nothing truly significant, the roll response to control inputs, just a little bit loose, predictable enough to do the task and

Pitch, about the same, just a comment I guess there was when I raised my... the pilot bandwidth on those... in the pitch axis, I did get that little unusual noise, but during the task performance I never saw it, it was only when I was feeling the controls out.

Undesirable oscillations? You know, I got very mild oscillations. I tried the slow approach, I tried the aggressive approach, I get basically one big oscillation that damped out, so I would say those were all right. Desired performance, if trying to get desired performance resulted in unacceptable oscillations, I would say that didn't occur. Probably HQR 3.

CONFIG 120 – SL5

Pilot: Wells

Run 526

Pitch and roll attitude responses to control inputs were somewhat less than predictable. The reason was that any control input seemed to excite an oscillation. And the oscillation was relatively a short period oscillation and it was very lightly damped, if at all. And it was related pretty proportionately to the size of the control inputs. So **when I tried to fly it aggressively I got some pretty large oscillations in the airframe, and when I tried to fly it smooth I got smaller oscillations. But oscillations nonetheless, that made the attitude responses difficult to predict.** And when I would bring it to a stop, and try to back out of the loop during a hover, the oscillations of the airframe would cause the aircraft to translate fore or aft or left or right, depending on which way they were going and would take them out of the desired box. So the pilot couldn't back out of the loop, it wasn't one of those systems where the pilot can keep his hands off and the aircraft is a little more stable that way. The oscillations were so lightly damped that they would continue, even after the pilot took his hands off the controls. And they would cause the aircraft to move out of the desired box. Again, unique pilot technique would be attempting to be smooth on the controls so that one doesn't excite the oscillations and almost a reluctance to make control inputs once you are stabilized. More likely to just accept the small amount of drift and make a control input, because almost every control input excited the oscillation. So that would be the unique pilot technique, would be attempting to be smooth on the controls.

I think I will go with a 6 on this. Very objectionable deficiencies.

CONFIG 130 – SL4

Pilot: Stortz

Run 425

Pitch and roll response were good and predictable. The load, the load oscillations are, I wouldn't say very easily excited but somewhat easily excited. The effect that the load has on the helicopter is to jerk it around with attitude changes, whereas the previous configuration gave me both attitude excursions and this one is strictly in terms of velocity excursions when I'm translating and position excursions when I'm trying to stabilize.

The oscillations do tend to damp out with time during the stabilization. And that's good. The load oscillation is qualitatively or descriptively not quite the level of moderately objectionable, but the workload to deal with that is more than moderate compensation.

The fact that... the major objectionable feature is the load oscillations and what it does to the helicopter, and that is position excursions during stabilization. And I'm calling that moderately objectionable. It does damp out, which is a mitigating factor, and the assigned HQR is 5.

CONFIG 130 – SL4

Pilot: Wilson

Run 203

There are some undesirable movements. Control responses to counter that seems to be, seems to be fairly predictable but there is some residual oscillations in the aircraft as a result of the load.

Here it's a lot more predictable when you... when I roll to the left to start my deceleration it stays there, and in turn it bites and it stops me quicker than what I have been accustomed to on the previous configurations. So then I have to come in with the smaller amplitude control inputs to fine tune my translation rate to capture the final hover position

Pilot technique was just to keep the aggressiveness down. HQR 4.

CONFIG 130 – SL4

Pilot: Tucker

Run 211

Once again, it looks like a very nice configuration as long **as you are being very smooth with it**

If you get into a corner and use abrupt inputs, I notice on this configuration more than any I have seen during this period seem to have sort of the bathtub effect longitudinally. I felt rather just translating fore and aft

HQR controllable, adequate, satisfactory it is. I think I would give you a 3. That's because there are some things hiding out there that with a little bit of off nominal control inputs, a pilot, you can actually raise your own workload considerably

CONFIG 130 – SL5

Pilot: Wells

Run 539

Pitch and roll attitude responses were not very predictable on this configuration. The reason being that every control input seemed to have a second order response, a control input would lead to at least one, if not two, overshoots of the final attitude. And it made it extremely difficult to predict what the final attitude was going to be, both in pitch and in roll.

It didn't seem to excite oscillations that lasted, it just seemed to be one or two overshoots every time. And this also made position and velocity responses not very predictable. The interesting thing was when the aircraft was brought to a stable hover, the pilot could back out of the loop and it was an extremely stable aircraft, it would just about stay in the

desired box without any pilot inputs at all. So it was very stable in that respect. But the lack of predictability made it extremely difficult to bring it to a decel or bring it to a stable hover and do so within the desired time, HQR is a 6.

CONFIG 130 – SL5

Pilot: Simmons

Run 558

This one is a little different, I don't remember one like it. Then I can hardly sense that there is a load at all. There is some kind of, you know, secondary kind of motion, but it's nothing like some of the others we have had. So the pitch response to inputs seems, you know, I don't know, it's like I'm on a rocking horse here in the pitch axis and kind of like sliding up and down on a slide. I'm not getting true pitch and I'm not getting, you know, a lunging effect, but there is something very peculiar in the response that I sense in the pitch axis. **And it's quite quick**, so, you know, it's like it's connected to the end of the stick, but it's different. And I can't put my finger on it.

The roll axis, getting pretty predictable response there, I guess. It didn't seem to be too much of a problem. It seemed... there is something different but I can't put my finger on that, either. It's probably just... this is one of those that kind of nags at you, I can't quite figure out what's going on.

Position. Position, to maintain a position in the longitudinal was very difficult. It felt like I was sliding up and down on this a little, like I'm on a slide, but it's bow shaped like a rocking horse and I really couldn't find the right kind of attitude to put in to hold position, a lot of effort. load, it seems to be an aircraft response issue and that the... I can't sort through the longitudinal and the pitch response, they are kind of an unusual relationship.

If desired performance resulted in unacceptable oscillation, did you decrease the goals to alleviate the problem? What I found was... well, I didn't really relax the goals too much. What I tried to do was avoid the large inputs, but I found myself still getting into it. So I can't explain exactly why, and I didn't feel that relaxing it seemed to help me any, so I went ahead and tried to stay up on the loop, on the step for the times.

This one I probably would give a 4 and a half

CONFIG 130 – SL5

Pilot: Sullivan

Run 718

Did undesirable oscillations occur? Yeah, especially in the pitch axis. The roll axis wasn't as bad. There were oscillations and they were definitely aggravated by the external load.

Trying for desired performance did result in unacceptable oscillations in question 4, and I did decrease the goal to adequate performance during one of the maneuvers and the oscillations were diminished.

CONFIG 140 – SL4

Pilot: Wilson

Run 663

The low frequency oscillations in the aircraft appear to be influenced by the load. It reduces the predictability of the velocity changes when you establish an attitude. I decreased the aggressiveness of the maneuver trying to reach desired performance and I was able to get the time down, but stationkeeping I think was touching more into adequate. And that kind of describes question 5. **The pilot technique was to just keep the aggressiveness down.** HQR=5.

CONFIG 140 – SL4

Pilot: Tucker

Run 695

The basic aircraft actually has a reasonably good bandwidth and general characteristics but it's like the load is easily excited. I don't see it in the fuselage, but I see the load motion starting to get excited with very little change in the attitude. So I find, what I think I'm seeing is the load driving the aircraft, which makes a reasonably good aircraft, I think, be a little bit harder to fly

I'm just trying to stay away from exciting the aircraft too much, knowing that the load appears to be easily excitable. So that's pilot technique HQR=5.

CONFIG 140 – SL4

Pilot: Gerdes

Run 1017

I'm having a little bit more problem in compensating for the load swing. And I'm seeing it in trying to hold the velocity as well as decelerating and also during the stationkeeping there is a wandering fore and aft that I try not to get in phase with, just try to stop it. I can still do that. But the workload is fairly intense.. Give it a 4.5.

CONFIG 140 – SL4

Pilot: Tucker

Run 1028

My sense initially is that the flight control system was a little bit higher bandwidth than the last (Configuration 110), good initial control and the sort of phasing of roll and translation with respect to control seemed quicker and I followed the control better. There was a strong sense of the load being active underneath, so I was surprised that with like 9 or 10 knots going into the decel, I could still get it to decelerate fairly nicely. There is a lot of control activity and feels like there is still a lot of load activity. It's not very comfortable to fly, but we still got amazingly good times and actually desirable performance.

And I would say that again the rating is around a 5. And the time seems to be okay, but I find that the amount of effort required to keep up with the position, you just have to focus on it all the time because it's a little bit hard to predict exactly where the aircraft is going

to go. If you get it excited, it's much harder to follow. And I'm very surprised that a slow transition would actually make it more complicated to fly. So the rating is 5

CONFIG 140 – SL4

Pilot: Dunn

Run 1092

The position and velocity responses to attitude changes were predictable to an extent, i.e., what I found was that this load, if you excite it, would actually give about one or two oscillations and then damp down, but the first oscillation it would tend to move the aircraft and the pilot had the tendency to counteract that, which then, of course, I think was completely out of phase with it probably, and tended to continue the excitation process. If you get out of the loop, then the aircraft would settle down quite quickly. As I said, it seemed to be fairly well damped. And so if the pilot would just allow the aircraft to stop and then move with it a small input, that was the best technique.

Undesirable oscillations, which is what we are talking about, which you can aggravate or excite if you get aggressive with the aircraft. If you went up on the speed during the run-in, the workload increased during the deceleration. If you are up at 10 knots, the workload was much higher than if you were down at 6 to 7 knots. 6 to 8 knots was quite controllable and I think the pilot workload was acceptable coming in at the slower rate. However, you could still excite that load and you have to change your techniques a little bit as to how you are going to handle that oscillation. I never decreased the goal to adequate performance, I didn't think it was necessary, if you typically stay within the desired performance throughout the task.

Unique pilot techniques necessary? My technique was to hold the speed down and to try not to make a large input and get the load excited. If the load did get excited because you came in a little aggressive, then the best technique seemed to be to get out of the loop, because it damped down quickly, and then move the aircraft, rather than trying to move it while the load was still oscillating, in which case you would tend to be part of the excitation function. For an HQR, actually I would give it a 4. I was tending to go slightly higher to 4 and a half because it seemed to me that the change in technique that was a requirement to allow it to damp down by itself, is not completely normal. But I gave it a 4 based upon the fact that, it's certainly as good as the previous system (160), which had what I thought was. less damped and therefore moving around a lot more and the pilot inputs were, I think... there were more of them. They were more frequent on the last system. On this system, once it got damped down, it was good. Once you got in the hover and everything was damped, it was very simple to sit in the hover and maintain the desired parameters. The problem was really getting damped down. So I gave it 4 for the pilot workload to get it damped down into the hover, but not too bad.

CONFIG 140 – SL5

Pilot: Sullivan

Run 647

Question 3, did undesirable oscillations occur? Yes, they did. In both pitch and roll. If so, did the oscillation seem to be aggravated by the external load? Yes. That was

definitely doing it, both during the translation maneuver and during the decel maneuver. The funny thing was is that it seemed as though there were... there was a couple good oscillations, maybe one or two, especially in pitch, but once it got settled down it seemed like this configuration was pretty rock solid.

I seem to have better luck during a more aggressive deceleration than I do during a slower deceleration. HQR=4.5

CONFIG 140 – SL5

Pilot: Wilson

Run 661

What seemed to work best was the slight decrease in aggressiveness, shooting for about the 7 knot entry speed and then small, smooth, small, low rate attitude changes to minimize any effect that the load might have on the predictability.

HQR=4.5

CONFIG 140 – SL5

Pilot: Gerdes

Run 677

I saw more or less unpredictable motion due to the load swing than previous ones. However, I was able to maintain desired positioning with of course increased pilot compensation. There was fore and aft unpredictable velocities, which were due to the load.

From what I could tell, just about all of my performance for the hover was within the desired. So I'm going to give that a 4, almost a 4 and a half, but I didn't go into the adequate range at all, so I'll give you a 4

CONFIG 150 – SL4

Pilot: Tucker

Run 344

Attitude responses to control inputs seemed predictable. Position and velocity responses were predictable. Undesirable oscillations, I would say no. I tend to see them if I push it too hard, if I pulse the system when I'm in close I'll probably end up with a handful, but I find just to do the task it's done quite satisfactorily with a nice smooth deceleration a few feet out. It seems like with a little bit of side flare and rolling level it can be done with a minimum amount of oscillations, certainly not objectionable. Desired performance is pretty easy to obtain. HQR=3

CONFIG 155 – SL4

Pilot: Stortz

Run 622

Pitch and roll response were generally satisfactory. The load tends to oscillate and the load oscillation seems to be easy to excite. I never did get it damped down where I

considered it hanging solidly beneath me. There is always some oscillation going on. That's objectionable. Undesirable. My initial impression on the first run was that it was really a handful. I thought I was looking at, in trying to decide between Level 2 and Level 3, I guess subconsciously accommodated the responses and found a compensation scheme. I wasn't aware of doing that consciously other than just trying to settle it down. The continuous load oscillation is the dominant and objectionable characteristic.

Motion cuing seemed reasonable.

HQR-wise, yes, it was controllable, and yes, adequate performance attainable with tolerable workload, not satisfactory without improvement. The load oscillation is moderately objectionable. And the workload is considerable. With this higher level of workload, I'm, the majority of the time, able to get desired performance but the workload is high. And I'm sweating bullets, as they say. So it's an HQR 5.

For question 8, the load oscillation did have a significant impact, it's what keeps me in the loop and working hard. And that load oscillation is the answer to No. 9 as well.

CONFIG 156 – SL4

Pilot: Stortz

Run 632

Pitch and roll response seems very sluggish. Attitude predictability is extremely poor. Consequently my ability to control velocity is very poor and the same with position.

The load oscillation is easily excited and just attempts to keep it in the box, aware that the oscillation is easily excited, and trying to select my inputs as best I can, still did not produce satisfactory control.

I think it's significant that on my first attempt at this the oscillation was excited so extensively that I had to abandon the task and work just to stabilize the oscillation.

Motion cuing seemed reasonable.

HQR-wise, the first question, is it controllable? Yes. It is controllable. Adequate performance attainable with tolerable workload? The answer is clearly no.

And when I try to do the task with any, any precision on the task, I excite the oscillation. The oscillation appeared divergent, I had to abandon the task and go for control. When my task is just maintaining control, that's easily done and considerable compensation is more than is required to do that. So what I'm saying is just stabilizing it takes less than considerable control. So adequate performance not attainable with maximum tolerable compensation, controllability not in question.

Well, the crucial decision here is this controllability issue. When I push it hard I go into a PIO, that's a controllability issue. I'm going to rate this HQR 8, because of the excessive oscillation that causes me to abandon the task.

CONFIG 160 – SL5

Pilot: Gerdes

Run 233

The pitch, roll, yaw and position and velocity responses were all much more predictable on this case. Very small oscillations. And again, I'm not even sure I had a load on there. If I did, it was one that was quite controllable. I did not find myself having to back-off, unquote, on my loop closure there. I could have stayed with more of a high frequency input type of pilot loop. I'm going to give this a 3. **If I could give you a 2 and a half, I might do that, but HQR of 3.**

CONFIG 160 – SL5

Pilot: Gerdes

Run 240 –

This is not the best one I've seen this afternoon. And it's, I sort of classify it again in between, one where I need to tell myself to back off. I noticed that. Obviously load dynamics coming in there. So once I got to the hover point, tried to stabilize, I found myself starting to over-control it again. So I had to back off.

The technique used, I had to use that what I call now back-off technique.

And I'm going to give that a 4 and a half.

CONFIG 160 – SL5

Pilot: Simmons

Run 130

Describe any unique pilot technique that you found necessary to accomplish the task. Just in general the technique was extremely small inputs to get it stable. I tried not to pulse the controls or put them in fast because the response seems to be very slow. Everything was pretty well damped, so I could just put the input in, wait, and hold it steady.**very low frequency inputs seemed to be the order of the day.**

And the highest workload, again, was in longitudinal axis once I tried to hold position, and that's where the technique, initially I used almost pulse type techniques in longitudinal axis to hold position until the load began to stabilize. I tried to sense where I thought the load was and put inputs in to keep it from pulling me off position. And then as it stabilized, I could almost back out of the loop and hold position there at the end.

It's fair, some mildly unpleasant deficiencies, that's primarily the pitch response or the longitudinal response while the load was oscillating, but it damped out. So minimum compensation probably is a little bit too light. It's definitely HQR=3 because of the decision tree, but I would say more than minimal compensation there. Did the load have a significant impact on the assigned HQR? It didn't have a significant one because I guess I would say the learning curve was up before the evaluations and I knew what the load pretty much was predictable, I knew exactly where the load, workload was going to increase, very short duration and it was over. So that's why it didn't significantly affect it. Had the oscillations continued, it might have.

CONFIG 160 – SL5

Pilot: Simmons

Run 188

Following comments were made after flying 210 and giving it a 5

The attitude was predictable yet the position response was not as predictable. And this one was much more noticeable in roll than the last one (Config 210), which was pretty stable in roll. This actually feels like a much heavier load underneath, like there is a lot more effect on the aircraft from the sling load.

Were there undesired oscillations? And the answer there is yes. And they are very pronounced in the lateral axis this time. And yes, the oscillations were aggravated by the load, which was more predominant.

Okay. Question No. 5, describe unique pilot technique you found. As far as unique pilot technique other than I found I had to pay a lot more attention in the roll. I was being pulled by the load, but I was getting very little attitude change from it. **So there were more side cue forces than there were the load actually putting a roll in which required pilot correction** to it. So it's almost like there were false cues because **the cues were pretty much lateral accelerations.**

Yes, it was controllable. We got adequate performance and I would say it's still a tolerable workload. Satisfactory without improvement? I guess I would have to say no. I wasn't getting desired time a couple times and it was due to predictability of stationkeeping and I guess we were on the fringes of being out of the box there a time or two, too, so it's obviously in that borderline area again. I'd say it's more than a minor annoyance, though, probably more than moderate compensation. And we were probably 50 percent done... I guess I'm going to have to give it a moderate objectionable deficiency. It's totally different than the last one I had, but it's... falls about the same place. Adequate performance required considerable pilot compensation. **HQR 5**, I think.

ENGINEER: Rick, one thing I would like you to comment on, you mention feeling heavier load or feeling something more in terms of the load effects. Can you talk about that for just a minute in terms of what... how you were feeling that or what the cuing was?

THE PILOT: Sure. I'm basically trying to compare it with the one I had before. The load I had before I could feel some load impact on that first load that I had. And it felt like it didn't have as much effect on the aircraft, therefore I sensed that it was a lighter load. This one seemed to have much more impact on the aircraft. And I sensed it more in the lateral axis, which made it feel like, you know, proportionately it was a higher load than the one I had had before. And that the load itself had more impact on aircraft dynamics than the first one.

CONFIG 160 – SL5

Pilot: Simmons

Run 193

Made following comments after flying 210 again and giving it a 3

Did the oscillations seem to aggravate the external load? Just a little bit. The load seemed a little less predictable maybe is the word. I had a less sense of what the load was doing in this one than I did some of the other configurations. If trying for desired performance resulted in unacceptable oscillations, I guess I would say the answer there is

probably no. It was like I had a long period that I was just out of phase with, but it didn't seem to be the big dynamics that I had in some of the other configurations. So I was getting desired performance there and adequate performance probably, I think a couple of times when I backed off... I don't think that was the right answer to it.

Question No. 5, describe unique pilot techniques. I think I had to tighten my crosscheck, and I found I was much more intense on the control inputs and so I was trying to make very, very small inputs. And tried to avoid the large inputs. And that was about the only change in technique.

The HQR, I guess I'd say it was controllable, we got adequate performance, it was tolerable workload. Satisfactory without improvement? I'd have to say no. I think I got desired performance throughout, got all the times and stationkeeping was desired, but my workload had to be stepped up to moderate level. So HQR 4.

CONFIG 160 – SL5

Pilot: Simmons

Run 309

This one, basically it felt like it was a much heavier load underneath. That was the basic thing. However, it seemed to be nicely behaved, nice damping issue.

Velocity response to attitude predictable, in fact I tried to get a little more aggressive there and still got good response and good hold, a nice steady 9 knots. And position response to attitude change was nice predictability. There is a little bit of a nuisance motion, you know, I could feel the load pulling a little there, but it didn't seem to disturb the aircraft. So I still got good position response to attitude. Undesirable oscillation? It was. marginal on the undesirable oscillations. They were controlled. But I could still feel them and there was a tendency to want to be more active than I had to be. But it was still, I guess, oscillations didn't seem to get out of hand.

I got desired performance throughout and I didn't have to drop down to adequate to hold position.

Motion cuing was reasonable, again I could feel the dynamics of the load a little more than some of the ones I've had before. I felt like it was heavier, seemed to have more inertial effects, kind of felt like it was pulling the aircraft but it didn't seem to pull the aircraft out of position, so it felt all right.

Satisfactory without improvement? This is borderline. Hmm. It seemed like I had a more mental workload here. I actually, I probably have to say no here. This is... this is a hard one. I'd say it was minor but annoying deficiency and it seemed like the load was, I get this sense the load was too big or had too much inertia for this... So it may be HQR 4.

Summarize the deficiency that makes the configuration unsuitable for normal accomplishment. I would have felt a little uneasy if I had to carry this load the way it was responding in a tight place and having people working on the ground, and that's partly it because I never could really sense what the load itself was doing other than I could feel it being pretty heavy. It seemed to damp out all right but I didn't have a good feel for it. So that was the main reason. Maybe it's just a little, I guess anxiety still describes it better.

CONFIG 160 – SL5

Pilot: Wilson

Run 658

On this configuration it felt like the load was more, had more damping than the previous configuration (210). I didn't have as much trouble once I actually trapped the final hover, the oscillations in the load stopped. It did not seem to have as much of a tendency to get excited as in the first configuration (210), it was almost kind of a real low amplitude neutrally damped oscillation, you were just kind of standing there within a plus or minus 2... between 2 and 3 feet hover. This, once you got the oscillations damped out, it was almost a hands-off hover, and it was not naturally excited at all. But I did come up with some form of control combination that I did get the load moving to the point where I did not call final stable until, I think it was 19 seconds.

I didn't seem to have as much problem at the 10 knot point, that might have just been, might have just been luck.

I did achieve desired performance on the majority of the runs, certainly adequate with one out-lier.

Deficiencies, minor but annoying deficiencies, yes. Desired performance requires moderate pilot compensation. I will give that a 4 as well. I think that answers the questions.

And again, it was again the character of the response that... in trapping the final hover position, the residual motions caused by the load oscillating. HQR = 4.

CONFIG 160 – SL5

Pilot: Wilson

Run 853

The thing that distinguished this configuration was that at the higher entry velocities the load seemed to be excited to the point where if I got into the loop with it, it would get divergent, and on a couple of the runs I was actually going outside desired tolerance. And I compensated that by decreasing the aggressiveness in the maneuver, just like that last run, coming in at 6 knots, drifted in there, and it seemed to stay well within desired, even though the aircraft was moving around a little bit. But it doesn't seem like it was an amplitude to where that I had to get into the loop and try to chase it. But when I did get in the loop, velocity changes with attitude changes were not predictable. It would all depend on where the load was in its swing when I would retrim the attitude. No real unusual pilot technique. Once the load gets swinging there is really nothing you can do, if it doesn't dampen out by itself.

Minor but annoying deficiencies, desired performance requires moderate pilot compensation, I think describes the configuration pretty well. So I will assign an HQR 4.

CONFIG 160 – SL5

Pilot: Wilson

Run 872

What's tough about this configuration is that even as low as the 6 knot entry velocity, it did get the load excited to where I was actually touching and actually went outside the desired tolerance. Sometimes it got aggravated and sometimes it didn't, but nonetheless it was still there.

And 9 knot entry velocity seemed to work out better than the 6. I don't really know why.

The last run, which was at 6 knots, seemed to work out pretty good, didn't get the load excited. But during the 30 second hover, I did chase it around, once I did get in the loop I did get some longitudinal movement. It didn't seem to be relevant in roll, roll wasn't any problem, but some longitudinal oscillations. And again, once the load does get moving, the velocity changes with attitude changes, the predictability goes down. **But these are small, these aren't gross errors, gross movements in the aircraft. It's still, you know, 90 percent plus time staying within desired.** But as far as trapping the hover target, I could do just about anything I wanted.

And then once I got stable in the hover chasing it around a little bit, I did have to get into the loop and there was this longitudinal movement that I described.

Is it satisfactory without improvement? Fair, some minimal pilot compensation. I will make the cut at Level 1 there. I'll give it an HQR 3.

CONFIG 160 – SL5

Pilot: Wells

Run 177

We will go with an HQR of 3, minimal pilot compensation. I guess, and we were able to achieve desired performance, most of the time, especially at 6 and 7 knots. So I will give it a 3 in that respect.

And No. 8, did the load have a significant impact on the HQR? Not a significant impact. It probably... it probably might have been... it might have been a 2 without the external load, but the load's oscillations were small enough that it didn't really have a significant impact.

CONFIG 160 – SL5

Pilot: Wells

Run 224

Pitch and roll attitude responses to control inputs were predictable. They were slightly slow to develop and, and for a set control input there was a slight oscillation in the air frame, especially in the roll axis, more so than the longitudinal.

Did undesirable oscillations occur? Yes, they did. During the translating portion, there were undesirable oscillations in the roll axis and then during the hover portion there were oscillations in the longitudinal axis. The oscillations had a relatively short period and the aircraft didn't require the pilot to make a lot of corrections, the aircraft seemed to be responding to the oscillations and I actually at times took my hand off the cyclic and the aircraft stayed within the box, so I actually went open loop a couple times and it stayed there, even though the aircraft was oscillating, even the air frame was oscillating.

The pilot technique, again, as with the other cases, using the slower air speeds, makes a pretty large difference, staying between 6 and 8 knots reduces the time and makes it quite easy to stay in the desirable. Getting up to 10 knots makes for some pretty large oscillations during the decel maneuver.

I also found that during the decel, that if you use a very gradual decel with this configuration that the air frame is much more stable during the hover portion. Once you call stable the aircraft is truly stable. Those were the times when I was able to take my hand off the cyclic and the aircraft remained within the box. it's definitely a 3 and possibly at the lower, at the very slow air speeds and making a very early decel, it's even approaching a 2. There was very little compensation required if you can hold it to 6 or 7 knots and make a nice gradual decel. We will call it a 2 and a half. There is some mildly unpleasant deficiencies, but I can say that with some technique you can overcome those and still remain within the desired performance quite easily

CONFIG 160 – SL5

Pilot: Wells

Run 259

Pitch and roll attitude responses to control inputs, they were predictable initially, and they had a pretty short time constant, it was a pretty responsive aircraft, but I think that the load caused some of the roll inputs to wash out so that an initial input in the roll axis would lead to a particular attitude and then that attitude would return more to the level and you would either have to compensate by adding slightly more roll or just allowing the roll to fluctuate back and forth, to oscillate as you approach the hover pad. I didn't feel it as much in pitch, although I could feel there was an oscillation in the pitch but it wasn't as pronounced.

Were position and velocity responses to attitude changes predictable? Yes, they were. I was able to achieve the desired ground speeds that I was trying for on each run. Did undesirable oscillations occur? Yes. Occurred both during the translation over to the hover point and during the hover. During the hover the oscillations were particularly pronounced in the longitudinal axis I found that I couldn't get stable within the 13 seconds when I was at 9 and 10 knots, so I decreased the air speed to roughly 6 knots for most of the runs in order to get to desired time.

The unique pilot technique would only be that the air speed I used was 6 or 7 knots and not 8, 9 or 10 knots for the run-in to the hover point.

Because, like I said, if you were even moderately aggressive it required considerable pilot compensation to maintain it within the hover box. And greater than one input per second. So I'll go with about 4.5 on the HQR.

CONFIG 165 – SL4

Pilot: Gerdes

Run 951

This was a load condition that I felt I had under control. And it's a big improvement over the previous one (Configuration 166). I was aware of load swings, but I seemed to be able to control it.

And on question number 3, the oscillations were, as I said, aggravated by the external load but small and controllable as compared to, especially as compared to the one previous to this condition.

I did try to back off and get my time closer into 13 seconds and that seemed to help. And I did not have to revert to attaining adequate performance because desired was certainly attainable. So the answer to question 4 is no.

On question 5, it was important here to use the technique of small inputs, moving into and out of the accel to the hover point as well as deceling and then maintaining the hover. And it seemed to work. I consciously tried to let the helicopter stabilize the load and if I saw any small creeping forward or aft, primarily in this case, then I would try to put in a small input. Pretty standard pilot techniques, though. **I call it the don't make waves technique.**

And the cuing was good, the motion cuing helped me to assess the degree of load swing. And there was no disorientation.

On the HQR, I had to work a little bit harder on this one. I could attain desired performance with moderate pilot compensation, so I will give this a nice solid 4.

CONFIG 165 – SL4

Pilot: Stortz

Run 970

Attitude responses to cyclic input seemed satisfactory. Reasonably predictable. The load oscillation is easily excited and that feedback of the load makes control difficult.

Control of velocity is not very precise because of the changes due to the load oscillation. And upon stabilization it seems that even the most minor input excites the load oscillation. The workload trying to achieve desired performance is unreasonable. And the load oscillates excessively and it's very objectionable, undesirable. Opening the performance band to adequate allows me to repeatably stabilize it in the adequate box within the time constraints, actually within the desired time constraints. But in so doing the oscillations are excited and the workload, in keeping it in that desired box, is rather high. It almost seems as though the SAS is exciting that oscillation. I'm not quite certain about that, but very small inputs, very small inputs excite the load oscillation.

Unique pilot technique, only opening up to adequate performance improves it, but not very much.

Motion cuing seemed okay. Maybe I'm getting used to it.

Yes, controllable, and yes to adequate performance with tolerable workload. Not satisfactory without improvement. The load oscillation is very objectionable and achieving just adequate performance

Requires more than considerable compensation. HQR 6. End of comments.

CONFIG 166 – SL4

Pilot: Gerdes

Run 948

There is night and day cases here. The previous run (Configuration 160) being a good one. This one being close to a Level 3, or uncontrollable. What I found is that I try to accelerate over toward the decel point with as little input as possible, yet I find that as I move, and this is unique to this case, as I move over toward the decel point I can feel the load starting to swing. And any attempts I make to try to alleviate that it just goes almost into a divergence, it keeps getting greater and I feel somewhat helpless. The predictability goes to almost zero. As far as position and attitude both, one time when I got to the decel decision point I already had the load swinging and when I decelerated, no matter how gradually I tried, it just started swinging more. Very frustrating. So on questions 1 and 2, very unpredictable.

On question 3, yes. Very undesirable oscillations did occur. And I tried to back off and that didn't seem to do any good. Probably because I tend to be a tight loop closer, just by nature. And it just didn't seem to do any good. So on question 3, the undesirable oscillations occurred and they were definitely aggravated by the load.

Okay. On question 4, I was unsuccessful, tried to back off and do adequate performance and it got to be real bad.

On question 5, I think I talked about that. I tried to be as steady as I could on the acceleration over to my 7 knots and even then as I was moving over at constant velocity I started to build a load swing. I got a pilot in the loop oscillation. It certainly was a pilot induced thing. The motion cuing was good, it's the only really cuing I had.

Motion was good. And no disorientation effects there. Just not a good condition all around.

Okay. HQR. Is it controllable? Actually I made a statement that it wasn't controllable. As far as load control, trying to damp out the oscillations, I would say it was almost uncontrollable, I was not able, with the cuing I had available here, not being able to see the load I was really not able to stabilize it. However, the aircraft was controllable. And I would say the adequate performance was not attainable. The tolerable pilot workload, that's the key issue here that gives me a right turn into Level 3. I think with maybe a lot of practice and maybe some people on the ground showing me where the load is going I might be able to develop, improve my performance. But as of right now it's not a tolerable pilot workload. So a right turn into the Level 3 area.

Well, I guess this is right on the borderline, then. As I read adequate performance requires extensive compensation on 6 and yet adequate performance not attainable. So I was back and forth between the two. But I want to mark this with a 7, just to indicate how awful I think it is.

CONFIG 191 – SL5

Pilot: Gerdes

Run 366

General comments, this looks like a good, another good one. I never got into a load swing PIO type of thing, which I have seen in the past. So control of it was still desirable but I had to work pretty hard to do it.

And once I established steady stable, I saw very little in the way of fore and aft, although there was some I'm going to say there are some deficiencies there. I'm noticing a little bit more of the, of the load dynamics. If I could give you a 3 and a half, I would.

But I'm going to give it a 4. It's on the Level 2 side. Let's see. The annoying deficiency would be this residual load swing after you've either accelerated to some velocity or the decel to the stable position.

CONFIG 191 – SL5

Pilot: Wells

Run 380

Question 3, undesirable oscillations did occur. It was a very... **it was an oscillation that mostly appeared in the roll axis.** It seemed to have a very short period and I'm not positive that it was aggravated by the external load, so I don't know the answer there. But **it was an oscillation that one could actually ignore, and if you tried to counter it, it led to a lot of control inputs from the pilot.** But I found that if you backed out, backed out of the loop, it would stabilize pretty quick and the aircraft was relatively stable on its own without the pilot getting in the way. And even when the pilot backed out of the loop, the oscillation is still there. It's still a pretty rapid oscillation, but it doesn't drag the aircraft out of the desired box, so you are able to maintain desired performance given that oscillation. I'm going to rate it at a 3, But the oscillation is still present and it's a mildly unpleasant deficiency, I mean it doesn't feel like an oscillation that's caused by an external load, unless it's on an extremely short arm there.

CONFIG 191 – SL5

Pilot: Gerdes

Run 522

I get a slightly undesirable oscillation in the roll, the perception on the lateral axis was that **I put an input in and then the load would respond and I could feel a lateral acceleration, like I was being pulled sideways. And then some time after that, it seemed like I would get a roll in the opposite direction, kind of a stabilizing effect.** It was a strange feeling in that the lateral acceleration and roll response, but it wasn't totally uncomfortable, it was just strange. Okay. **And that was mainly in the roll.**

Pilot technique. Again, there is a little bit of pilot anticipation, when I felt the lateral acceleration I would go ahead and put the inputs in instead of waiting on the aircraft to respond in attitude change. Other than that, it seemed to get better performance by kind of quickly neutralizing the attitude and the position and then back out of the control loops and let the aircraft sit there. That seemed to work pretty good. I would say the response was still mainly just an annoying response. so HQR 4 just because there is a lot of mind

games going on, I would guess that the load is what's causing me some concern in that lateral axis.

CONFIG 192 – SL4

Pilot: Simmons

Run 518

The roll response inputs during the translation first seemed like it was a little bit loose, and the second or third time I didn't seem to notice that as much, and got pretty good response on the translation, but wasn't able to damp out, it seemed like I got out of phase with the roll in station-keeping.

Pitch. Pitch on this one wasn't much of a factor. Didn't seem like I did much in the pitch axis at all. So it was, I guess, predictable in pitch. I didn't notice it.

Position. I was working harder in the lateral axis this time and there seemed to be a position response to attitude changes, it seemed to be, as I put the control inputs in, I was getting like an out of phase response when I was doing the stationkeeping. It's kind of hard to explain, but as I moved the stick I would feel the lateral acceleration almost in the opposite direction initially, so something not quite in sync. And if I tried to just sit there and try a level attitude, I could get out of sync with it while I was doing stationkeeping. And it's kind of a mild roll oscillation that just didn't feel right.

I guess I could call that an undesirable oscillation, I call it undesirable in that it wasn't gross like some of the others we have seen where you really fight for control, this one was undesirable in that I just had... I could not seem to damp out the roll oscillation, it was a real nuisance.

And was it aggravated by the external load? I get the sense in this case that it was. This load did seem to be much more significant. It was obvious it was there. Much more noticeable in the longitudinal axis, again, the pitch axis was pretty benign.

Let's see, if trying to get desired performance resulted in an unacceptable oscillation, did you decrease your goal? When I would just try to sit there and let it go, just... it wasn't comfortable to just let it sit there and rock. So I found it very difficult to back out of the loop and let it rock. So when I tried to get more aggressive with it, I could almost stop the roll change, but then I could feel the lateral accelerations, which were unacceptable. So I couldn't find a compromise on that one.

Describe the unique pilot technique. I kind of, kind of hunted in the middle, I tried to control the roll enough to damp out that oscillation without getting unacceptable lateral accelerations, because those didn't feel right.

Motion cuing. About the only thing I would say is that I did get this, when I upped my lateral bandwidth, I was getting a funny kind of lateral acceleration. It just didn't seem to be in phase with what I thought the motion should have been.

Well, the deficiency that I sensed there is more of an annoyance, and in the deceleration I wasn't sure, and I guess I would say maybe it's the predictability that made me not sure as to whether I had things nulled out before I would call stable. I'm teetering here, I probably didn't get desired... well, I got desired performance half the time. So I guess I

would say it was just enough to maybe performance was not fully predictable in the desired range, so I would probably have to go to the 4 and a half there, just on performance, at the performance level, because I was only getting it half the time. And it was annoying. So I can't say it was moderately objectionable, it wasn't that bad. So 4 and a half. And this time it's more of a performance issue than it was a workload issue.

For question No. 8, external load, yes, I think it had a significant impact. It felt like it was, you know, maybe a medium length sling is the perception here, but a significant load. And it didn't seem to want to damp out in that lateral axis.

I think that summarized No. 9 pretty much, it was a matter of... the performance was not totally predictable to be desired. Workload, didn't seem whether I increased the workload or decreased my workload, I would still slide into that corner of adequate performance. So mainly performance driven handling qualities. Level 2.

CONFIG 210 – SL4

Pilot: Simmons

Run 131

NOTE: Simmons flew 210 seven times and gave 3 fives, one three, one 4.5 and three 6's for an average HQR = 5. The overall average without Simmons was 4 and with Simmons was 4.4. Simmons average was HQR=5. Simmons was given 210 and 160 back to back several times.

Pitch and roll attitude response was lower predictability than I had before (160), it seemed like it was sluggish, it seemed like lower bandwidth, was the general perception. If the control system was the same, then it feels like it's a bigger load because there seemed to be some other force than... my inputs seemed to be less predictable.

Position response, again I'm having a little problem in the longitudinal. If I can keep the requirements down to low attitude changes that I'm getting okay response, but it's additional pilot compensation in order to keep within the... the limits of what I think I can control and stay in desired.

I did get some undesirable oscillations this time, not only in the load, I really had to work hard to keep the oscillations down with the load, because their response to the vehicle then became unacceptable. So in working harder to get smaller inputs, I could keep the oscillation right at the limits of what I figure I could control.

I got desired performance, again I could lower the standard a little bit right to the limits and stay... and keep the oscillations to where they were controllable, and still get the desired performance most the time. Although the position was I was having a problem staying on that adequate border. So not all the time.

If applicable, describe any unique pilot technique that I found necessary. **I found more so than the last configuration (160) necessary to try to limit the aggressiveness of the deceleration, because this one, the residual oscillations seemed to have much more effect on me, or the control response seemed to be much slower**, whichever it is, I couldn't tell. So I had to be a lot less aggressive on the initial deceleration so that I could control it once I got in there. That was probably the primary thing.

A lot of times that compensation actually was backing out of the loop, not being aggressive, but trying to convince myself not to be aggressive. So I'd say it would be an HQR 5.

And did the load have significant impact on the assigned HQR? I'm assuming that the, the perceived lower bandwidth, this is just my assumption at this point, is probably due to the external load. So I would say yes, that has something to do with it. Of course the oscillations and the resultant aircraft response was the second half of that, so I would say yes. And we are Level 2, so summarize the deficiencies that make this configuration unacceptable for normal accomplishment of the task. I would say that the pilot workload **is too hard to achieve and get repeatable desired performance. And here it's a mental workload of having to back out of the loop to keep from exciting the modes which made it difficult to control.** And that should be the end of it.

CONFIG 210 – SL4

Pilot: Wells

Run 163

Were position and velocity responses to attitude changes predictable? Not necessarily. when the load is moving that the velocities don't necessarily correspond with the attitude of the aircraft. **Sometimes at a perfectly level attitude, the aircraft can translate. It's more pronounced in longitudinal than it is in lateral,** but it is there. I think I was able to make the desired by keeping the ground speed down to about 6 to 7 knots. I think when they hit about 8 knots or above, then the control inputs required to come to a stop are a little bit large and cause the load to oscillate a little bit too much. Then the pilot workload goes up tremendously, I'd say it could be improved. Therefore I'd say that we fall in that No. 4 HQR rating. was causing the oscillations.

CONFIG 210 – SL4

Pilot: Simmons

Run 183

I'm getting initial response but then there is a residual response that kind of causes a rocking horse effect there at the... until the load stabilizes. Did undesirable oscillations occur? the last two times did pretty much a normal deceleration but ended up with **residual oscillation in the longitudinal axis,** which was undesirable. And they were aggravated by the load, it was pretty obvious, it took me a while to get it dampened out, probably 20 seconds or so. I was trying to do smaller inputs which would let the position wander a little bit and I still had the oscillations. I was biased by my first two when I might have said this would have been just a minor annoyance, but the last two runs I found to be moderately objectionable, so I think the harder I tried the worse it got.

I would have to say the adequate performance required considerable pilot compensation and part of that was to try to make the smaller inputs. HQR 5.

I've got a slightly higher gradient in lateral than I do in longitudinal stick. And the longitudinal gradient is pretty mild. And there is a tendency to, possibly to overcontrol in pitch as a result. So I think that needs bearing, looking into. **The load obviously seemed to affect me more in longitudinal axis,**

CONFIG 210 – SL4

Pilot: Simmons

Run 192

Position and velocity response to attitude changes predictable? Looks like I was getting very steady velocity going across in the deceleration, I was coming out just about on desired spot each time, which is definitely different than the time before (160). Position keeping once I got there seemed to be very easy. Undesired oscillations occur? I would say the answer there was no. It seemed to be nicely damped. Oscillations didn't, you know, what oscillations there were didn't seem to be aggravated by the external load. If anything it seemed like the load kind of stabilized the aircraft dynamics. I found actually my intensity could be lowered tremendously. **I got a very predictable deceleration rate and then once I got into position, here is where the, I felt that I didn't really have to correct the attitude changes, that the load was changing the attitude of the aircraft in such a way that it was stabilizing and the load swung to the left, it rolled the aircraft to the right, which basically maintained position. And once I observed that, it was not difficult at all to just let the aircraft do most of the work for me. It was more stabilizing in effect. So I backed out of the loop because I didn't have to get in it and that helped some.** Minimal pilot compensation was required. It really comes out an **HQR 3**.

Did the load have a significant impact on the assigned HQR? And I guess I could answer that two ways. I'd say the load didn't make the position keeping any more difficult, and if anything the dynamics were stabilizing, so they helped, it helped, the control system combination with the load helped itself hold position, so it minimized pilot compensation.

CONFIG 214 – SL4

Pilot: Gerdes

Run 600

I found that I was perturbing the fore and aft load swing once I got into the box, once I got over to the hover point. And sometimes if I get out of the loop, once I saw I was stabilized I just sort of relaxed and I could keep the thing from swinging. But it started to move a couple of times and it moved further than I had predicted. Then I put in a quick correction and it just made it worse. So there is a greater degree of unpredictability here, particularly in the position and velocity control. It also affects the attitude, but you really see it in position, because that's what you are trying to hold. And it is unpredictable, because you will get a swing and it will settle down and then you will get another one, and so forth. So 1 and 2 are both negatives, that is unpredictable. Going over, trying to keep a constant line of sight going over to the hover point, I noticed maybe a little bit more fore and aft, probably because the load may have been oscillating a little bit more fore and aft. But once I got there, **lateral line-up was not the problem, that fore and aft was.** I'm going to call this a 4 and a half. 4.5

CONFIG 214 – SL4

Pilot: Stortz

Run 1485

The load interaction is the dominant feature. It's somewhat easily excited but damps down after a few oscillations, and by a few, I mean like four or five. The predictability of positioning during the oscillation is not very good. Once it damps down and the inputs are slow and deliberate, I can get desired performance with reasonable workload. So the oscillation is undesirable. It's somewhat easily excited, I won't say it's very easily excited. And desired performance can be achieved provided I remain... provided I do not get very aggressive with it and do not excite very large oscillations. In this case motion cuing did not seem reasonable. I have described it before and for the record now it's like that load sliding around in the back of the cargo bay and you feel some motion in the direction that it's going and then it hits the edge and you feel a sharper, not really a jolt, but a different change in the... or change in the way it reacts. So it's kind of like it's banging around a bit but it's soft edged. I don't think that cuing is reasonable. It's hard to imagine a swinging load acting like that. It doesn't cause disorientation or anything, it does affect the predictability of positioning when that's going on. desired performance requires only moderate compensation, with the caveat that I mentioned earlier, as far as not maneuvering aggressively and purposely slugging (lagging?) the inputs, that's moderate compensation. The rating is HQR 4.

CONFIG 214 – SL4

Pilot: Tucker

Run 1601

The load now becomes more lightly damped, it's much more... has much more of an effect on the aircraft. In terms of pitch, roll and yaw attitude response to control inputs, here is a point where the load is actually having a sufficiently strong effect on the attitude to make the attitudes not quite so predictable with input. Also it has something to do with diminishing your ability to estimate the velocity and position.

Undesirable oscillations, I would say yes. I found that using the best technique that I could come up with I couldn't isolate the oscillations. I found them bordering on being neutral, neutrally damped. I definitely skirted between desired and adequate performance. Mostly the adequate came from being out of the box on the back side, but clearly is a case of not being able to get good direct control of the vehicle, so I'm always... there is some considerable phasing between my control input and the output of the aircraft, which makes it considerably more difficult to fly.

I think a 5 with considerable pilot compensation for adequate performance is accurate. It's a rating of 5.

CONFIG 214 – SL5

Pilot: Wilson

Run 763

There was some, some effect of the load during the translation, as evidenced by a lot of sliding around, the actual track wasn't very linear. **Most noted in pitch or in X axis fore and aft.** The load seemed to have quite a bit of influence on the aircraft. I was having to really concentrate on being as gentle on the controls, not to get it excited. Fine tuning my position to keep within desired actually excited the load oscillating on two runs that I can

recall. I actually got the thing going to where... I actually got outside the desired tolerance. And it didn't seem like it was damping out, the more I got into the loop the worse it was getting. I found myself being as gentle as I could be, real tight into the loop, all the way from the initiation of the maneuver, because once the load got excited, then it didn't seem to dampen out and it would result in some tracking problems. I will give it an HQR 5.

CONFIG 215 – SL5

Pilot: Wilson

Run 767

We did get some undesirable oscillations, some predictability problems with velocity changes, with attitude changes.

Decreasing the aggressiveness of the task seemed to improve the outcome, but the oscillations at a hover were such that if the load was oscillating, if it was excited, it didn't seem to want to damp out. Kept it within adequate, but keeping it within desired was difficult. I think on a couple seven second runs I was able to drift in and capture the final hover position without exciting the load and in turn stationkeeping was within desired. But any oscillations in the load at all kept it within adequate and outside desired.

That kind of describes technique, again just decreasing the aggressiveness. I wasn't playing any lead filtering or any integrator, you know, doing any integrating. But you really had to anticipate that the aircraft was not going to respond as you made an attitude change. So if you could anticipate that, it did help the outcome of the maneuver.

We were able to keep it within, well within adequate. It's still undesirable from the standpoint that once the load did get excited the damping was not enough to stop the load from oscillating and setting something down, oscillating that much would be difficult. I'll give it an HQR 5.

CONFIG 217 – SL5

Pilot: Simmons

Run 824

Pitch attitude response to control inputs was very low predictability. Hard to keep it from bobbing even on the translation. Pitch and roll were about equally bad.

Velocity response to attitude change, I found that a little bit low predictability. It seemed like I could easily be dragged 1 or 2 knots by the load if I got an oscillation going. And position keeping was definitely a chore. The oscillations were definitely aggravated by the external load. The sense I got was that the load responded as if the load was twice as big as the airplane, it was definitely dragging the airplane around wherever it wanted to go.

Let's see. When I was trying for desired performance, result in unacceptable oscillations, did decreasing the goal alleviate the problem? It didn't alleviate the problem. Basically when I just let the load drag me around in and out of the desired boundaries, and minimizing my inputs, I was able to reduce my workload a little, but it sacrificed the performance, so it was definitely a trade-off. On this one I really couldn't come up with a

unique pilot technique to alleviate the oscillations. I was able to mitigate them a little, but any precision attempt resulted in unacceptable oscillations. The pulse techniques would help keep them from getting too big, sometimes, and sometimes it seemed to play right into it. So I never could find a frequency of the inputs or size to keep the oscillations from still being objectionable.

Motion cues were extremely strong. Again, got a very strong sensation that the load was dragging me around, based on the motion cues. And let's see, let me think about it. There was some attitude change due to the load, I believe, but primarily it was the accelerations that the load was giving me that were strong.

For the HQR here, is it controllable? I guess so. I basically had to just back up and let the airplane fly me around. Not a good thing to be doing. I would say that was a major deficiency. I didn't think controllability was in question, I mean even though I had some pretty big oscillations there, I still felt I had control, but not very good control, so I'd have to give it a 7.

External load have a significant impact? The answer is yes. I would say in this case the load seemed to be more dominant than the airplane itself

I went down to a Level 3 deficiency. Configuration unsuitable to accomplish the task following the flight control failure. I felt I could marginally do this assigned task, very marginally at the speed specified (8 knots). And when I went to the high speed (12 knots) I think I would have had to almost abort the task. The tendency to get into a PIO had a potential for disaster there. That was the main objection, I believe. And I could not find any way to null the response so I could get out of the loop.

CONFIG 220 – SL4

Pilot: Gerdes

Run 41

This is a really high demanding task. And I discovered that any distraction, like looking down at the instrument panel, in this case was to check heading, caused me to lose my, my hover positioning precision. So it's just that close to a cliff hanger here as far as trying to stay in any kind of a near desirable hovering position.

Okay. Going down through the questionnaire here, the attitude response to control inputs is... borders on being, well, I'll just call it not predictable because of the effect of the load and it varies around depending on how much you disturb it, of course.

And the same with the velocity responses to attitude changes, you have got this additional load input. So we are, I think we have crossed the border to where there is at periods... there are times when we go into what I call unpredictable mode here.

And undesirable oscillations did occur there, they are the low frequency nature I have described and primarily induced by the swinging load. Those movements going up into the helicopter itself. It's definitely aggravated by the external load.

No. 4, certainly the external load had a, in this case a significant impact on my HQR, which I will give you. Okay. Again, pretty common comments here on pilot technique strategy with this load. **I find that I'm trying very hard to enter any maneuver in a**

way to not start the load swinging, and on a couple of my runs, one of them when I rolled out over the hover point, I did it just right so as I rolled out somehow I just damped the load right out and I couldn't believe how good I did that. And the next one was terrible, so it's hard to be consistent. But if you get the feel for where the load is or what it's doing, you can use that to assist in your roll-out and stabilization control strategy.

The coupled sling load dynamic certainly run this thing into a Level 2 here. And it's right on the border of desirable and adequate. I'm going to give it a 5 just to show that. I'm going to call it my performance was not desirable, it was adequate and it required considerable pilot compensation. That describes it pretty well.

CONFIG 220 – SL4

Pilot: Wilson

Run 329

Pitch and roll certainly predictable. I wouldn't have wound up with those times if they weren't. No yaw excursions and no yaw coupling that I was able to detect. Velocity and position responses to attitude changes were predictable at the gain that I was doing maneuver. **It was one steady smooth transition into the final hover target with very little influence from the load on the aircraft, very, very small perturbations. Felt more than seen. And it didn't require the pilot to get into the loop, require myself to get into the loop** - they were stable, you know, they weren't divergent, I just pretty much stayed out of the loop and let the aircraft bounce around a little bit. No undesirable oscillations occurred. There were some, but not undesirable. They were caused by the load. I did achieve desired performance, so the oscillations did not affect the performance. Normal control strategy, it's a very low gain task, starting the deceleration early, smooth, one continuous transition into the final hover.

Excellent, highly desirable pilot compensation not a factor for desired performance; good, negligible deficiencies pilot compensation not a factor for desired performance or fair, some mildly unpleasant -- I'd say good, negligible deficiencies, pilot compensation not a factor for desired performance. I'd say HQR 2.

CONFIG 220 – SL5

Pilot: Wilson

Run 801

Well, this is a difficult configuration to sort out because you could feel the aircraft getting influenced by the load by, what I was feeling was a lot of small.- kind of medium frequency oscillations. **mainly in roll**, and some in pitch.

The load at the higher aggressive tasks did tend to get a little bit excited during the 30 second hover, where I touched on the desired boundary a couple times. But other than that, it had pretty good, pretty good performance. **So we did get some undesirable oscillations and decreasing the aggressiveness did seem to work.** As far as the outcome of the maneuver. However, nailing and trapping that final hover position from

the decel, I was able to do it at speeds all the way up to 10 knots without too much of a problem.

We will go to the HQR. It's kind of a difficult one to sort out. Is it satisfactory without improvement? I'll say no. Minor but annoying deficiencies, yes, desired performance requires moderate pilot compensation. If I were to go up one, I don't know if we could state that we actually had repeated desired performance. I could, I feel like I could repeat desired performance at the lower aggressive tasks (lower speeds). Moderately objectionable, adequate performance requires considerable... that's kind of steep for this configuration. I'll go back to my first impression, minor but annoying deficiencies, desired performance requires moderate pilot compensation. I'll assign an HQR 4.

CONFIG 230 – SL5

Pilot: Gerdes

Run 45

230 is a bad one. General comments with this hook-up configuration, it feels like somebody else is on the controls or you are hovering in a gusty wind of some kind. It's just like there are two people, you and somebody else, flying the airplane sort of fighting over who has got control. Undesirable oscillations, certainly, from that load, the same as my previous comments. And one tries very hard not to start those going, by your inputs, trying to go in smoothly and then exit smoothly.

I would probably, if I could give you a half rating, I would give you probably a 7 and a half on this, but that's not allowed anymore, so I am going to give it an 8

CONFIG 230 – SL5

Pilot: Stortz

Run 55

Pitch and roll attitude responses are a bit sluggish. Predictability suffers. The effect on position and velocity responses is... degrades them somewhat.

No oscillations involved. And the external load was evident. It was reminiscent of the one with the long CG to hook distance, as I could feel it jerking my attitude around.

My compensation as far as dealing with the load was to try to do the decel smoothly with a little longer decel, longer decel distance a little less, sooner anticipation. And considering my excursions into the adequate performance range, which were brief and momentary on two of the runs, I would say it's not satisfactory without improvement. Generally desired performance is achieved but with moderate pilot compensation. So HQR 4 is the rating.

CONFIG 230 – SL5

Pilot: Stortz

Run 79

Pitch and roll attitude responses to control inputs predictable? Yes, they are. They are really... the standout feature of this configuration or this combination here is the load. I can really feel what the load does to the helicopter. I do have good, predictable responses

to attitude, so I've got that under control. But I seem to be able to easily excite the oscillation of the load, and that load oscillation is what's giving me the most difficulty.

Unique piloting technique; question 5. I really did not feel like I wanted to get very aggressive with it at all. I felt I wanted to be as smooth as possible and technique-wise this was the way I did it. I believe it's going to be HQR Level 2. And the deficiencies are the susceptibility of the load to oscillation, is the predominant feature that is going to result in Level 2.. I know that I could keep the helicopter there if I were more aggressive with it, and I have adequate response to do that, but I know that will excite the load, so my concern for not exciting the load oscillation is driving me to accept momentary excursions out of the desired performance band. But it's, it's not a... it's infrequent. This sort of puts me on the borderline between 4 and 5. So it's a long way of saying HQR 5.

CONFIG 230 – SL5

Pilot: Stortz

Run 91

Pitch and roll responses were good and predictable. The load oscillations are easily excited, and once the load is oscillating, that's giving me unwanted attitude changes and unwanted position changes in the hover, and giving me difficulty in controlling the velocity during the translation. The load oscillations just don't seem to damp out when I'm stabilized in hover and I'm fighting it the entire time. I can achieve desired performance, but at considerable effort, and I am never really happy with the way the load is oscillating. The workload goes down for trying just for adequate performance, but even with the broader bands of the... of an adequate bound on the task, the load still does not... I still can't get the load to stop oscillating. Okay.

I couldn't find the pilot technique to deal with the load oscillation. Helicopter control was adequate but the, as I said, the load oscillation is causing unwanted attitude changes in the helicopter and unwanted position changes. It's jerking the helicopter around.

HQR-wise, yes, it's controllable. Adequate performance with tolerable workload, yes. Not satisfactory without improvement.

When I was trying for desired performance and achieving it, compensation was more than moderate. The load oscillation is more than moderately objectionable. Well, I would call that load oscillation and what it does to the... how it feeds back to the helicopter is very objectionable. But achieving adequate performance requires only considerable rather than extensive compensation.

And as far as word descriptors, rating-wise I will assign HQR 6. The load oscillation is very objectionable and that's the standout feature of it. Okay. Question 8, yes, the load had a very significant impact on the assigned HQR. I think without the load the response of the helicopter is sufficient to achieve probably Level 1, certainly no worse than HQR 4. But the load makes it very difficult and it's very objectionable the way the load oscillates, is easily excited into the oscillation and how that affects the helicopter. That was the answer to question 9. End of comment.

CONFIG 230 – SL5

Pilot: Stortz

Run 97

Pitch and roll response were good and predictable. The load, the load oscillations are, I wouldn't say very easily excited but somewhat easily excited. The effect that the load has on the helicopter is to jerk it around with attitude changes, The oscillations do tend to damp out with time over the... during the stabilization. And that's good. I can achieve desired performance the majority of the time, you know, like 95 percent of the time, with a higher level of workload.. The fact that... the major objectionable feature is the load oscillations and what it does to the helicopter, and that is position excursions during stabilization. And I'm calling that moderately objectionable. It does damp out, which is a mitigating factor, and the assigned HQR is 5.

CONFIG 230 – SL5

Pilot: Tucker

Run 115

Certainly at first glance the configuration is quite the dog. I would assume that it's very low bandwidth. It's not sensitive to problems in yaw, but pitch and roll, very sluggish response. I don't have a strong sense of how I'm doing it, but it's one, very wise not to perturb the aircraft very much if the attitude starts to get off.

Of the runs, I would hate to have to fly this thing on any normal basis, but it does show you that it can be done, you can figure out how to fly it and then with a lot of compensation make it work, but it's a lot of effort.

I don't have a sense of the response being predictable, I end up with a little higher frequency low amplitude input where I'm just trying to nudge the vehicle to the position I want it, or the attitude where I want it rather than just clearly putting an input in and knowing that I will get a predictable output. So I'm actually kind of nudging it around.

It's amazing, you know, you can get desired performance out of it but you really do work unacceptably hard, and also you end up using unnatural control strategies to make it work out. So it's not something I would ever accept, I think, as being adequate for a mission.. And I would probably give it an 8. I would say that considerable pilot compensation is required for control.

It's a very squirrely configuration, but it can be flown. I don't know. I'm not quite sure how to rate it here. I don't... I read 7 and I read 8, and depending on how you look at it I could rate it with either. Why don't I give you 7.5 and stop talking.

CONFIG 290 – SL5

Pilot: Wilson

Run 701

Pitch and roll attitude responses, not very predictable due to the influence of the load on the aircraft. There was a lot of fore and aft drift and not a very linear acceleration.

Going into question 4, we did get desired performance as far as time was concerned on one of the runs and the control technique used for that was just to decrease the aggressiveness of the deceleration. I think I entered that one at about 7 knots and then at

the following one I entered it about, purposely, I think probably pretty close to 9, 9 knots, if not over. And that kind of had an exponential effect on the outcome of the maneuver.

It seemed like the oscillations were neutrally damped, you always had this kind of low frequency oscillation in the aircraft.

The load never dampened out, never got back to a, you know, a very stable aircraft.

Is adequate performance attainable with a tolerable pilot workload? I think we did achieve adequate tolerance, however the one thing that I probably need to talk about is you are at risk of damaging a load. If a load is swinging that much in your final hover position, when you do get the aircraft at a stable hover, and it's still swinging that much, you are at risk of damaging some equipment if you were to try to put the load down. But as far as strictly handling qualities, is adequate performance attainable with a tolerable pilot workload? I'll say yes.

I think moderately objectionable, adequate performance requires considerable pilot compensation answers all the questions. HQR 5.

CONFIG 293 – SL5

Pilot: Gerdes

Run 467

This is a good one, and I was able to control the attitude quite precisely on the way over and stop it precisely over the hover box. And I assume I had a load on there.

ENGINEER: Yes.

I can really get into the loop here without precipitating any pilot induced oscillations.

For question No. 5, normal piloting technique here. I could pretty much assess on the way over that the decel into the box was going to be a relatively easy thing to perform. So just standard pilot technique, nothing unique on 5.

It was good but I can't say that pilot compensation was not a factor for desired performance. So I will give it a 3.

CONFIG 294 – SL5

Pilot: Gerdes

Run 470

I was having a little bit more of a problem in keeping in the hover box fore and aft, the usual problem area we have. Generally the handling qualities looked good, except for that one part there, sort of like a cliffhanger, you are doing fine and all of a sudden it starts to drift. So there is certainly more load dynamics coming in there and disturbing the helicopter. Generally it looked pretty good.

Undesirable oscillations did occur, they were more noticeable here than in the previous configuration (Configuration 293).

Unique piloting technique - this is where I report whether I had to back off.

And here comes the HQR. I was having more of a problem holding it fore and aft. I was working pretty hard. So I'm going to go into the Level 2 area here and give you a 4.

CONFIG 295 – SL5

Pilot: Gerdes

Run 583

This configuration also looks like a good one. And very much like the one before it (Configuration 293). I'm finding that there is a little bit more fore and aft drift as I move over to the hover spot there. But it's really hard to tell any significant difference, I'm just working a little bit harder to hold over the spot.

On question 5, I had to back off a little bit on my control task in the piloted loop here, I had to back off a little bit to keep from overcontrolling. So that is sort of meant as kind of what I mean by the increased workload. But it still handled well.

If I could give you a 3 minus I would. I'm going to give it a 3.

Appendix C – Description of Simulation and Tasks

C.1 Math Models

Three math models were used in this simulator experiment: RotorGen with simplified load model, RotorGen with Cicolani load model, and the linear analysis model. The first of these was used for the early external-load simulations. The second model (RotorGen with Cicolani load model) was implemented for SL4 and SL5. The linear analysis model was used to generate the root-locus and Bode plots used in the supporting analysis described in sections 2 and 3.

The single-point external-load configurations are expressed in terms of the features shown in Figure C-1.

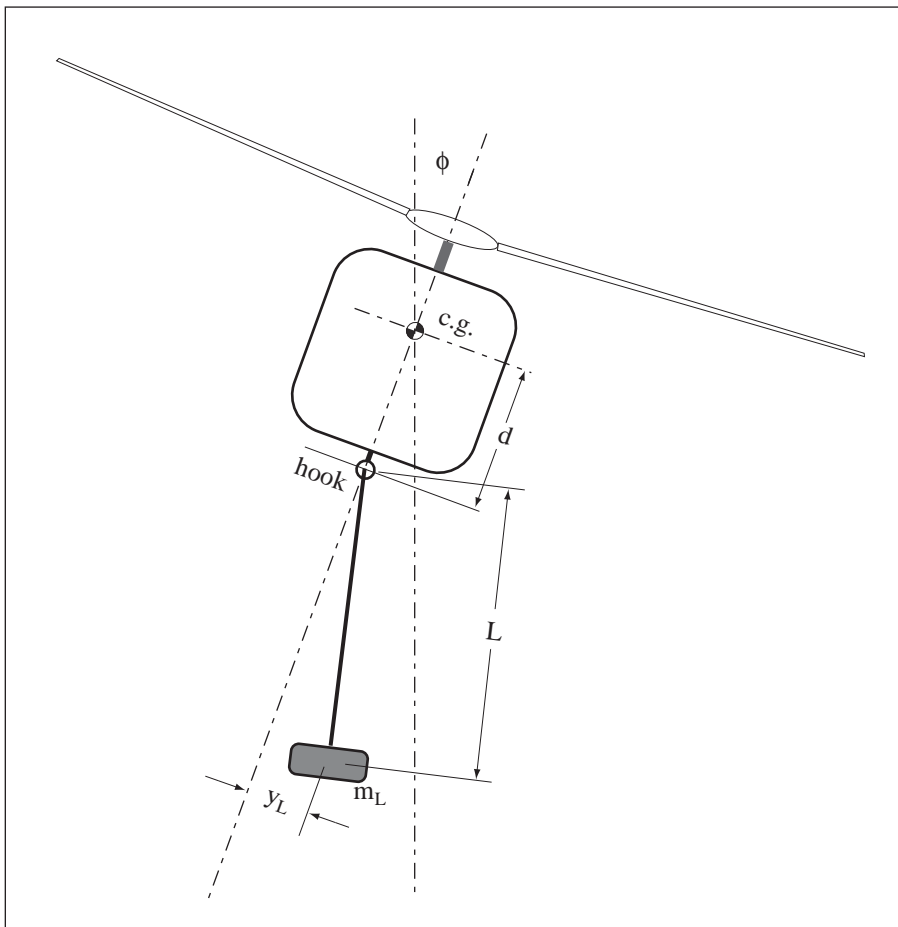

Figure C-1. Load Geometry (Single-Point Suspension, Roll Axis).

The simplified single-point suspension model, referred to as “RotorGen with simplified load model” is defined in reference 5 and consists of a point-mass load. The more complex Cicolani model, reference 6, involves fewer simplifying assumptions, and was used in the SL4 and SL5 simulations because of its face validity and the fact that there was no appreciable penalty in computational speed.

Simulation runs were made using the simplified single-point model. Comparisons with the simplified and more complex model results showed that the differences were negligible.

A simplified dual-point suspension model was run in order to examine its effect on the yaw axis, but this was a minor part of the simulator experiment. The dual-point model consisted of a load defined as a thin rod with a finite pitch and yaw inertia. The roll-axis dynamics using this load were equivalent to a single-point suspension point-mass load. Further investigations using a more complete dual-point suspension model may be conducted in the future.

C.1.1 RotorGen Model

RotorGen is a minimal-complexity, first-principles, generic rotorcraft math model. It can be configured to represent any specific rotorcraft type using geometric and mass features and refined as permitted using additional data that may be available. The model is currently used for manned simulation of large military cargo helicopters and, in particular, the Boeing Vertol CH-47 Chinook tandem rotor helicopter. The RotorGen math model is also configured as a conventional single-rotor helicopter.

Each of the RotorGen model components (rotor, wing-body, SCAS, external load, etc.) has been designed to balance overall complexity against quality of representation for manned or unmanned simulation. A good first-order portrayal of a rotorcraft can be obtained from the definition of the basic geometrical and mass characteristics. Empirical adjustment of various parameters can provide an increasingly better quality match depending upon the availability of validation data.

The RotorGen model is a refinement of a “minimal-complexity” helicopter math model developed under a prior Aeroflightdynamics contract and defined in reference 7. A desktop computer implementation of the current model includes three versions of the vehicle model along with a software pilot model and math models of several ADS-33 demonstration maneuvers.

The rotor component of the model is based on H. Glauert's representation of thrust, tangential hub forces, and rotor-induced velocity as functions of translational and rotational velocity components and rotor hub controls (ref. 8). This includes constant axial flow through the rotor disk, lift on the rotor blade proportional to incidence, and flapping expanded as a Fourier series (harmonics neglected). Squares and higher powers of tip speed are neglected.

The RotorGen tip-path-plane model is based on a modified quasistatic formulation of Chen's flapping equations (ref. 9). As a result, flapping angles are functions of cyclic, angular rates, and translational velocities. The tip-path plane is defined by flapping angles resolved in body frame. A first-order lag can be inserted to approximate the regressing flapping mode of the rotor.

Body forces and moments are based on a quadratic fluid dynamics formulation given by Horace Lamb in reference 10. The form used here contains selected terms that are applicable to low-speed flight, and downwash on the fuselage is neglected. The “quadratic-aero” form is compatible with conventional airfoil and bluff-body model forms and lends itself to easy linearization in various stability derivative forms.

For single-rotor configurations, a tail rotor model is based on momentum theory, and yields directly thrust and power required state variables. Torque and power calculations are based on a rational buildup of power-dissipation components that result directly from the rotor and body math models discussed previously.

As a direct result of the rational first-principles form of the rotor and body models, features that include conventional flight controls, stability augmentations systems, and rotor revolutions-per-minute (rpm) governor also can be included as needed. These additional systems can be generic models or explicit formulations of actual systems, depending upon availability of data or other considerations.

C.1.2 Cicolani Single-Point Suspension Model

The main external-load math model used in these experiments is that developed and implemented per reference 6. It was combined with the RotorGen aircraft math model in order to preserve the correct two-body equations of motion.

C.1.3 Linear Analysis Model

The simple model defined as follows was found to be an excellent approximation to the more complex solution used for the piloted simulation. Time histories from the simplified model were compared to results from the Cicolani model for every configuration with very good results. The linear analysis model was used to generate the transfer functions that were used to derive the handling qualities criteria. Yaw and heave axis dynamics are essentially decoupled from pitch and roll and do not seriously impact pilot handling qualities.¹¹

Airframe (two degrees of freedom)

$$\dot{p} = L_{\delta A} \delta A + L_p p + L_v v - \frac{d}{I_{yy}} Y_{hook}$$

$$\dot{v} = Y_{\delta A} \delta A + Y_p p + Y_v v - \frac{d}{M} Y_{hook}$$

ACAH SCAS (see section A-3)

$$\delta_A = K_{loop} (K_{\delta_A} \delta_A - \phi - T_L \dot{\phi} + K_I (Int Error))$$

$$\frac{d(Int Error)}{dt} = K_I (K_{\delta_A} \delta_A - \phi - T_L \dot{\phi})$$

Single Point Suspension, Point Mass Load

$$Y_{hook} = m_L \frac{g}{l_{sling}} y_L$$

$$y_L = \frac{g}{l_{sling}} y_L + g\phi + dp - v + l_{sling} \dot{p}$$

¹¹Note that the equations omit the second-order lag prefilter used in the simulator that is immediately downstream of the control input, δA . This filter is characterized by a natural frequency of 14 rad/sec and a damping ratio of 0.5. Omission of the filter simplifies the following analysis and does not materially affect any observations or conclusions.

The transfer functions generated from this model were compared to the higher order model used on the VMS by comparing time histories from a 1-inch, 1-sec pulse input, and by comparing Bode plots generated from the simulation using comprehensive identification from frequency response (CIFER). This was done for every configuration, and the comparisons were excellent in all cases.

C.2 Vertical Motion Simulator (VMS)

The simulator experiment described herein used the NASA Ames VMS facility at Moffett Field, California. This facility provides large-amplitude motion, a four-window ESIG-2000 visual system, and a generic cockpit with controls and instruments representative of a large cargo helicopter. The four-window outside visual scene provides a forward field of view that is approximately 90 deg to each side, and a downward-looking right chin window. The visual system scene generator has an overall transport delay of 70 millisecond (msec).

A cutaway drawing of the motion system is shown in figure C-2.

The simulator cab is configured with instrument displays and controls based on the CH-47D helicopter. The panel is shown in figure C-3.

Primary flight-control loaders in the simulator are set to match the forces of the CH-47D. A collective control lever is present in the simulator but is not used for the tasks performed in this experiment because an altitude-hold function is operating as part of the normal flight-control-system configuration.

The motion system of the VMS is optimized to maximize motion amplitude and response for the tasks. During SL-4, motion was scaled to permit the larger-amplitude normal departure/abort-to-landing zone task and lateral-reposition task. The precision-hover task is less critical. During SL-5, only the precision hover task is involved, and the motion gains were scaled up by a factor of 2.

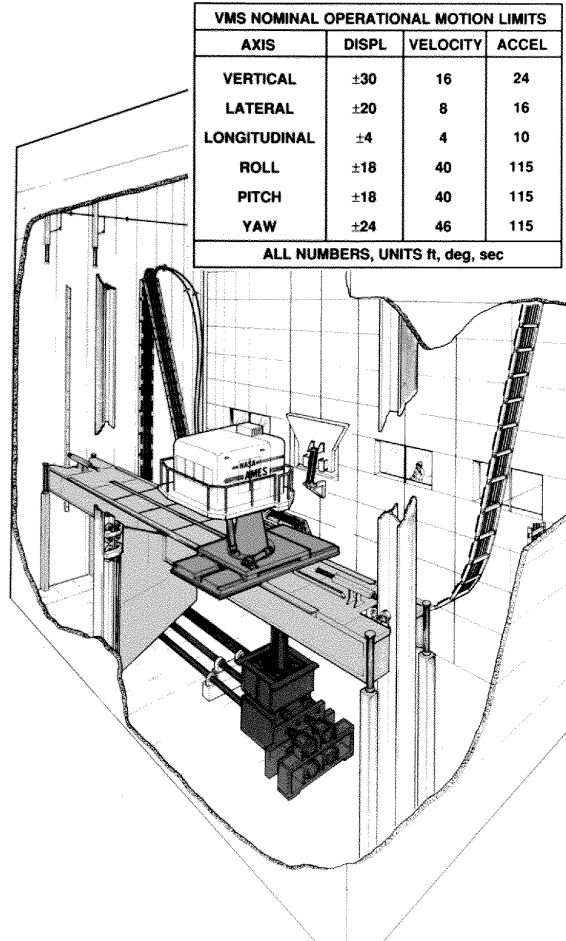

Figure C-2. VMS.



Figure C-3. Simulator Instrument Panel.

C.3 Task Descriptions

Four tasks were used to obtain pilot-rating data during the SL4 simulation.

- (1) Precision hover
- (2) Normal departure/abort-to-landing zone
- (3) Lateral reposition, and
- (4) Hover turn

These tasks were developed and refined during the flight tests conducted at NASA Ames Research Center using a Blackhawk. Each task was adapted to the VMS simulator environment with respect to controllability and visibility. Only the precision-hover task was used in SL5.

Although the VMS visual environment was nominally daylight and clear visibility, the visual cue ratings assigned in SL2 and SL3 showed that the usable cue environment was 2 (UCE = 2).

Each task is described in detail in the following section.

Precision Hover

The precision-hover task is the most demanding of those evaluated in this study because of the high degrees of precision and quickness in both x- and y-axes. It will be seen that external loads can produce substantial degradation in handling qualities as a result of the impact on quickness, settling, and precision.

Objectives.

- Check ability to transition from translating flight to a stabilized hover with precision and a reasonable amount of aggressiveness.
- Check ability to maintain precise position, heading, and altitude in
 - Day: the presence of a moderate wind from the most critical direction;
 - DVE: the DVE.

Description of maneuver. Initiate the maneuver at a ground speed of between 6 and 10 kts, at an altitude less than 6.1 meters (m) (20 ft). For the external load configuration, the altitude will have to be adjusted depending on the sling length. [In the simulation, the altitude was held constant at 30 ft, resulting in the artifact that the load was below ground level. The pilot could not see this. The target hover point shall be oriented approximately 45 deg relative to the heading of the rotorcraft. The target hover is a repeatable, ground-referenced point from which rotorcraft deviations are measured. The ground track should be such that the rotorcraft will arrive over the target hover point (see figure C-4). In the daytime (i.e., good visual environment), the maneuver is to be accomplished in calm winds and in moderate winds from the most critical direction. If a critical direction has not been defined, the hover shall be accomplished with the wind blowing directly from the rear of the rotorcraft.

Description of the test course. The course layout is shown in figure C-4. Note that the hover altitude depends on the height of the hover sight and the distance between the sight, the hover target, and the helicopter. These dimensions may be adjusted to achieve a desired hover altitude.

Performance standards. Accomplish the transition to hover in one smooth maneuver. It is not acceptable to accomplish most of the deceleration well before the hover point and then to creep up to the final position.

	HOV.A (attack)		HOV.C (large)		HOV.E (external load)	
	Day	DVE	Day	DVE	Day	DVE
DESIRED PERFORMANCE						
Attain a stabilized hover within X seconds of initiation of deceleration.	3 sec	10 sec	5 sec	10 sec	10 sec	13 sec
Maintain a stabilized hover for at least:	30 sec	30 sec	30 sec	30 sec	30 sec	30 sec
Maintain the longitudinal and lateral position within X ft of a point on the ground.	± 3 ft	± 3 ft	± 3 ft	± 3 ft	± 3 ft	± 3 ft
Maintain altitude within:	± 2 ft	± 2 ft	± 2 ft	± 2 ft	± 4 ft	± 4 ft
Maintain heading within:	± 5°	± 5°	± 5°	± 5°	± 5°	± 5°
There shall be no objectionable oscillations in any axis during either the stabilized hover or the transition to hover.	3	3	3	3	3	
ADEQUATE PERFORMANCE						
Attain a stabilized hover within X seconds of initiation of deceleration.	8 sec	20 sec	8 sec	15 sec	15 sec	18 sec
Maintain a stabilized hover for at least:	30 sec	30 sec	30 sec	30 sec	30 sec	30 sec
Maintain the longitudinal and lateral position within X ft of a point on the ground.	± 6 ft	± 8 ft	± 6 ft	± 6 ft	± 6 ft	± 6 ft
Maintain altitude within:	± 4 ft	± 4 ft	± 4 ft	± 4 ft	± 6 ft	± 6 ft
Maintain heading within:	± 10°	± 10°	± 10°	± 10°	± 10°	± 10°

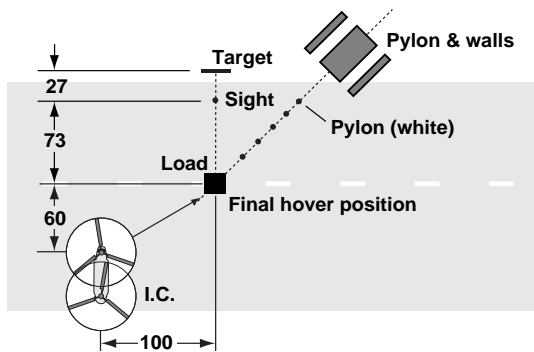

Pylons & Walls:

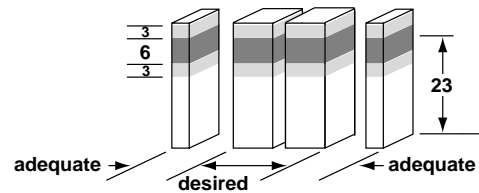

Front View, Target & Sight:

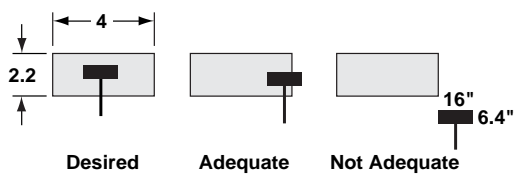

Side View:

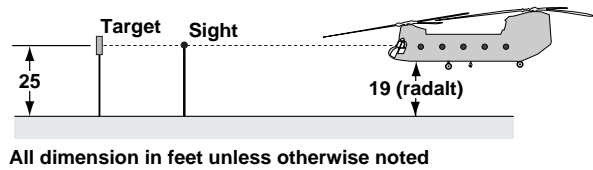

Figure C-4. Hover Maneuver Course Layout for the VMS Simulation.

Normal Departure/Abort to Landing Zone

The *normal departure/abort-to-landing-zone* task represents an aggressive, large-amplitude change in forward position with standards on how quickly it is done and how precisely the final position is achieved.

a. Objectives.

- Check pitch axis and heave axis handling qualities during moderately aggressive maneuvering.
- Check for undesirable coupling between the longitudinal and lateral-directional axes.
- With an external load, check for dynamic problems resulting from the external-load configuration.

b. Description of maneuver. From a stabilized hover at 35 ft wheel height and 800 ft from the intended endpoint, initiate a longitudinal acceleration to perform a normal departure. At 35 to 40 knots groundspeed, abort the departure and decelerate to a hover such that at the termination of the maneuver, the cockpit shall be within 20 ft of the intended endpoint. It is not permissible to overshoot the intended endpoint and move back. If the rotorcraft stopped short, the maneuver is not complete until it is within 20 ft of the intended endpoint. The acceleration and deceleration phases shall be accomplished in a single smooth maneuver. For rotorcraft that use changes in pitch attitude for airspeed control, a target of approximately 20 deg of pitch attitude shall be used for the acceleration and deceleration. The maneuver is complete when control motions have subsided to those necessary to maintain a stable hover.

c. Description of the test course. The test course shall consist of at least a reference line on the ground indicating the desired track during the acceleration and deceleration, and markers to denote the starting and endpoint of the maneuver. The course should also include reference lines or markers parallel to the course reference line to allow the pilot and observers to perceive the desired and adequate longitudinal tracking performance. The course layout for the VMS simulation is shown in figure C-5.

d. Performance standards.

	NDA.C (large)		NDA.E (external load)	
	Day	DVE	Day	DVE
Desired Performance				
Maintain lateral track within:	± 10 ft	± 10 ft	± 10 ft	± 10 ft
Maintain radar altitude below:	50 ft	50 ft	50 ft	50 ft
Maintain heading within:	± 10°	± 10°	± 10°	± 10°
Time to complete maneuver:	25 sec	25 sec	30 sec	30 sec
Maintain rotor speed within:	OFE	OFE	OFE	OFE
Adequate Performance				
Maintain lateral track within:	± 20 ft	± 20 ft	± 20 ft	± 20 ft
Maintain radar altitude below:	75 ft	75 ft	75 ft	75 ft
Maintain heading within:	± 15°	± 15°	± 15°	± 15°
Time to complete maneuver:	30 sec	30 sec	35 sec	35 sec
Maintain rotor speed within:	SFE	SFE	SFE	SFE

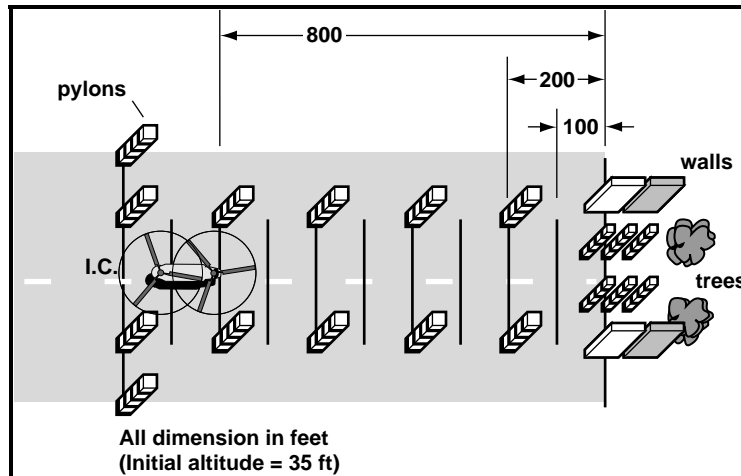

Figure C-5. Normal Departure/Abort-to-Landing Zone Course for VMS Simulation.

Lateral Reposition

The *lateral-reposition* task represents an aggressive, large-amplitude change in sideward position with standards on how quickly it is done and how precisely the final position is achieved. The maneuver is an approximate y-axis counterpart to the *normal departure/abort* maneuver.

a. Objectives.

- Check roll axis and heave-axis handling qualities during moderately aggressive maneuvering.
- Check for undesirable coupling between the roll controller and the other axes.
- With an external load, check for dynamic problem resulting from the external-load configuration.

b. Description of maneuver. From a stabilized hover at 35-ft wheel height with the longitudinal axis of the rotorcraft oriented 90 degrees to reference line marked on the ground, initiate a lateral acceleration to approximately 35 kts groundspeed followed by a deceleration to laterally reposition the aircraft to a spot 400 ft down the course within a specified time (including stabilization to the hover). The acceleration and deceleration phases shall be accomplished in a single smooth maneuver. The rotorcraft must be brought to within ± 10 ft of the endpoint during the deceleration, terminating in a stable hover within this band. Overshooting is permitted during the deceleration, but will show up as a time penalty when the pilot moves back within the ± 10 ft of the endpoint. The maneuver is complete when a stable hover is achieved.

c. Description of the test course. The test course shall consist of any reference line or markers on the ground indicating the desired track during the acceleration and deceleration, and markers to denote the starting and endpoint of the maneuver. The course should also include reference lines or markers parallel to the course reference line to allow the pilot and observers to perceive the desired and adequate longitudinal tracking performance. The course layout for the VMS simulation is shown in figure C-6.

d. Performance standards.

	LAT.C (large)		LAT.E (external load)	
	Day	DVE	Day	DVE
Desired Performance				
Maintain longitudinal track within:	± 10 ft	± 10 ft	± 10 ft	± 10 ft
Maintain altitude within:	± 10 ft	± 10 ft	± 10 ft	± 10 ft
Maintain heading within:	± 10°	± 10°	± 10°	± 10°
Time to complete maneuver:	18 sec	20 sec	25 sec	25 sec
Adequate Performance				
Maintain longitudinal track within:	± 20 ft	± 20 ft	± 20 ft	± 20 ft
Maintain altitude within:	± 15 ft	± 15 ft	± 15 ft	± 15 ft
Maintain heading within:	± 15°	± 15°	± 15°	± 15°
Time to complete maneuver:	22 sec	25 sec	30 sec	30 sec

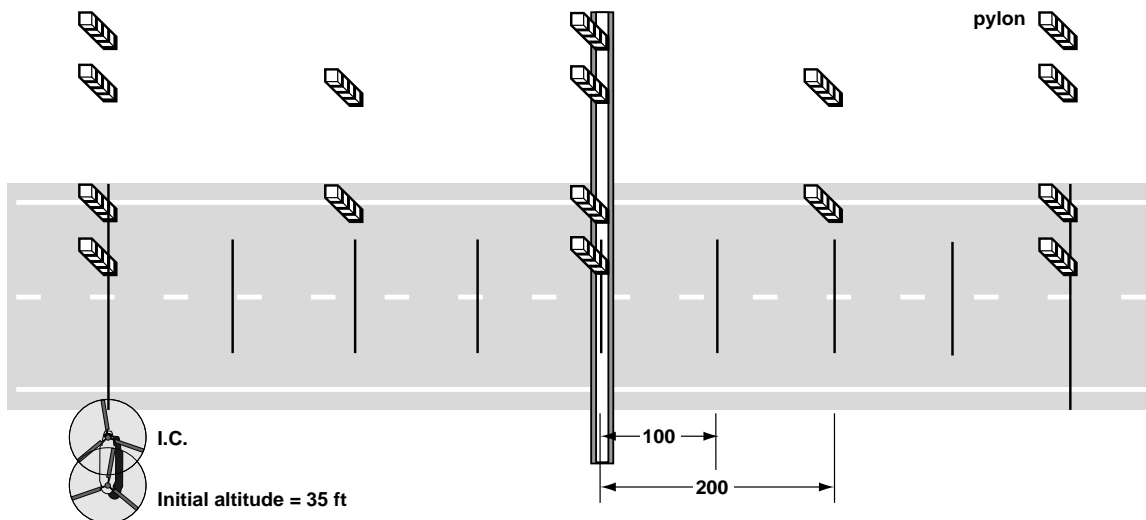

Figure C-6. Lateral-Reposition Maneuver Course for VMS Simulation.

Hovering Turn, 180-Degree Heading Change

a. Objectives.

- Check for undesirable handling qualities in a moderately aggressive hovering turn.
- Check ability to recover from a moderate-rate hovering turn with reasonable precision.
- Check for undesirable interaxis coupling.
- In the DVE, check for undesirable display symbology and dynamics for hover.

b. Description of maneuver. From a stabilized hover at an altitude of less than 6.1 m (20 ft), complete a 180-deg turn. Perform the maneuver in both directions. In the day, perform the maneuver with a moderate wind from the most critical azimuth. If a critical azimuth has not been defined, the turn shall be terminated with the wind blowing directly from the rear of the rotorcraft.

c. Description of the test course. The course layout for the VMS simulation is shown in figure C-7. This is basically the precision-hover course with two extra markers placed in the 6 o'clock position relative to the aircraft. The maneuver begins with the aircraft lined up on these extra markers and the hover target and board located at the 6 o'clock position of the aircraft

d. Performance standards.

	HT.A (attack)		HT.C (large)	
	Day	DVE	Day	DVE
Desired Performance				
Maintain the longitudinal and lateral position within X ft of a point on the ground	± 3 ft	± 6 ft	± 3 ft	± 6 ft
Maintain altitude within:	± 3 ft	± 3 ft	± 3 ft	± 3 ft
Stabilize the final rotorcraft heading at 180 deg from the initial heading within:	± 3°	± 5°	± 5°	± 5°
Complete turn to a stabilized hover (within the ± 3 deg window) within X seconds from initiation of the maneuver	10 sec	15 sec	15 sec	15 sec
Adequate Performance				
Maintain the longitudinal and lateral position within X ft of a point on the ground.	± 6 ft	± 12 ft	± 6 ft	± 12 ft
Maintain altitude within:	± 6 ft	± 6 ft	± 6 ft	± 6 ft
Stabilize the final rotorcraft heading at 180 deg from the initial heading within:	± 6°	± 10°	± 10°	± 10°
Complete turn to a stabilized hover (within the ± 6 deg window) within X seconds from initiation of the maneuver.	15 sec	15 sec	20 sec	20 sec

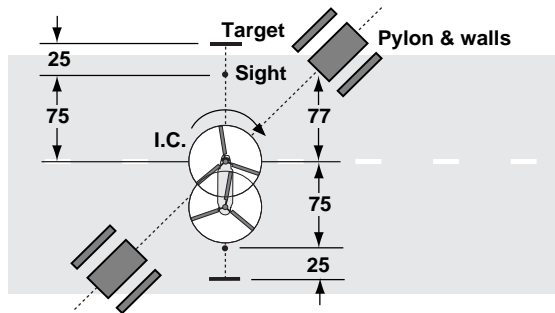

Pylons & Walls:

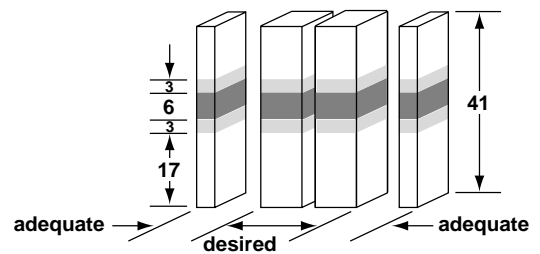

Side View:

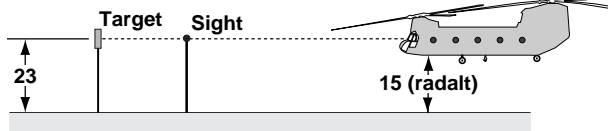

All dimension in feet unless otherwise noted
(Initial altitude = 15 ft)

Front View, Target & Sight:

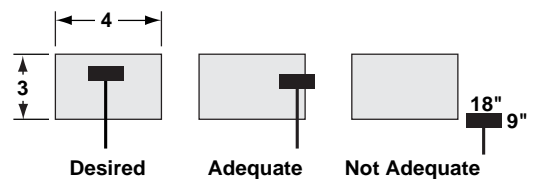

Figure C-7. Hover-Turn Maneuver Course for VMS Simulation.

Appendix D – Bode and Root Loci of Tested Configurations

D.1 Longitudinal Velocity

The root-locus and Bode plots for the \dot{x}/δ transfer function for each of the tested configurations are shown in figures D-1 through D-54. These transfer functions are the basis for the external-load criteria developed in this report (see discussion in section 2.3).

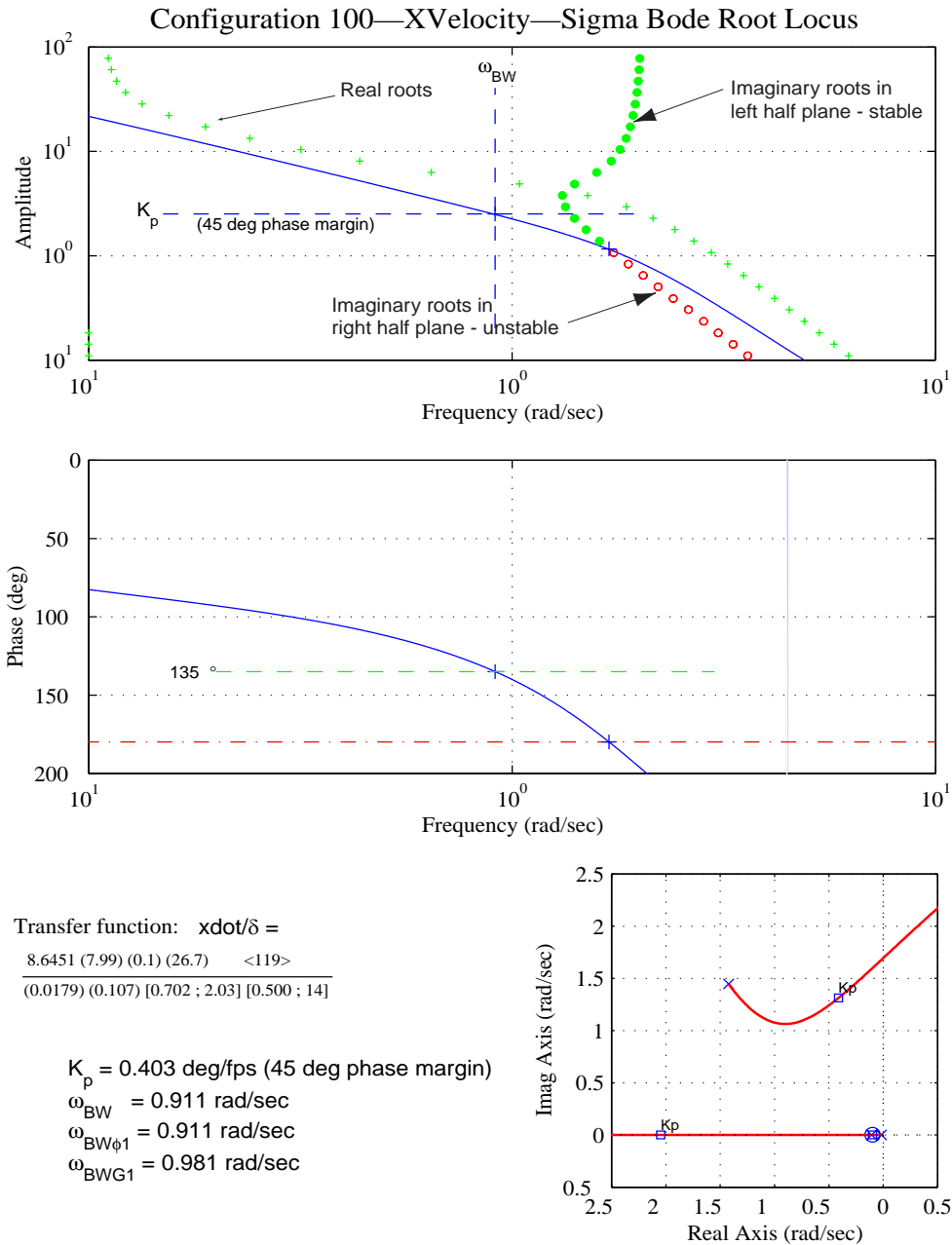

Figure D-1. Longitudinal Translational-Rate-Loop-Closure Characteristics – Configuration 100 – Load Off.

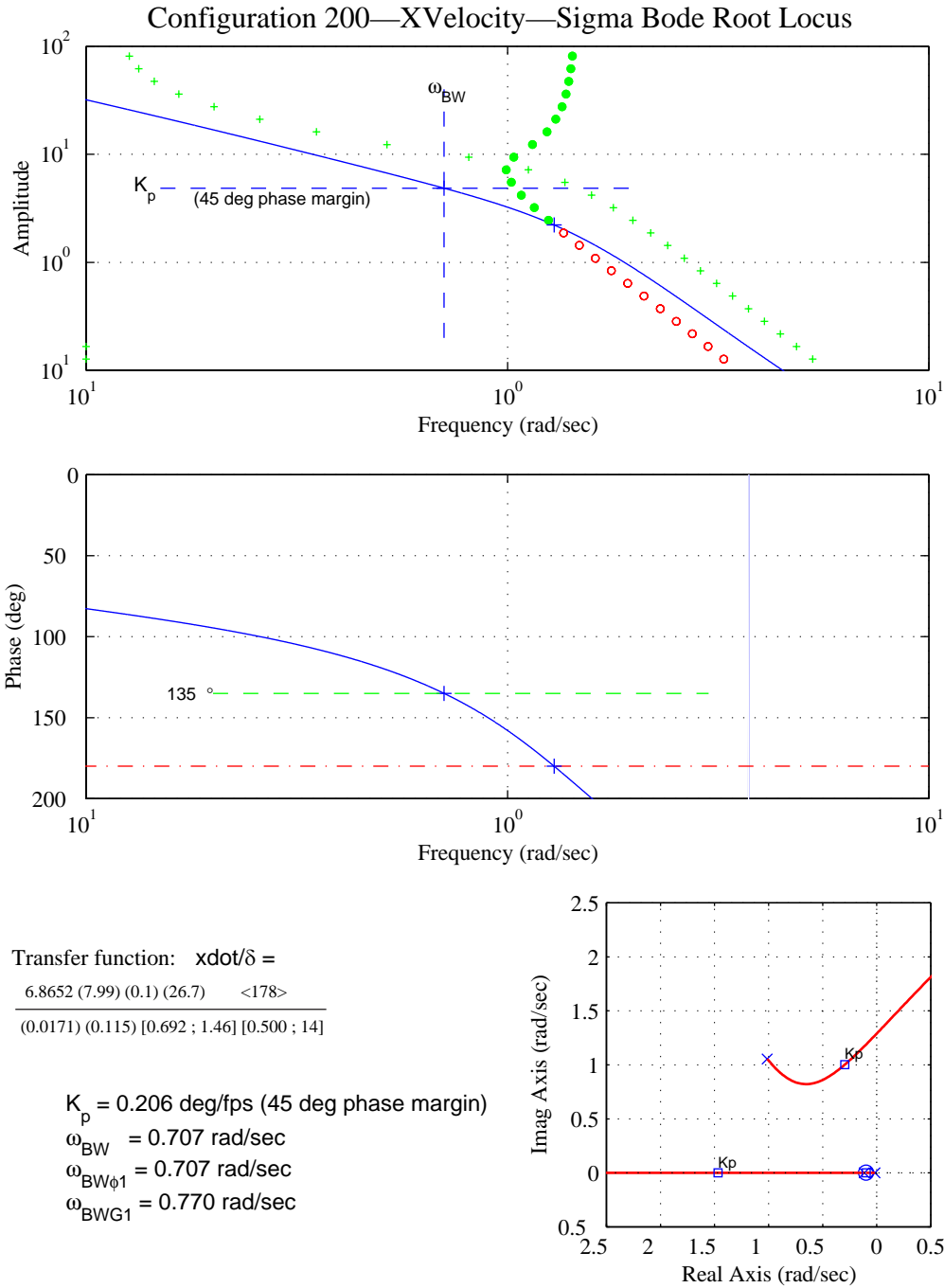

Figure D-2. Longitudinal Translational-Rate-Loop-Closure Characteristics – Configuration 200 – Load Off.

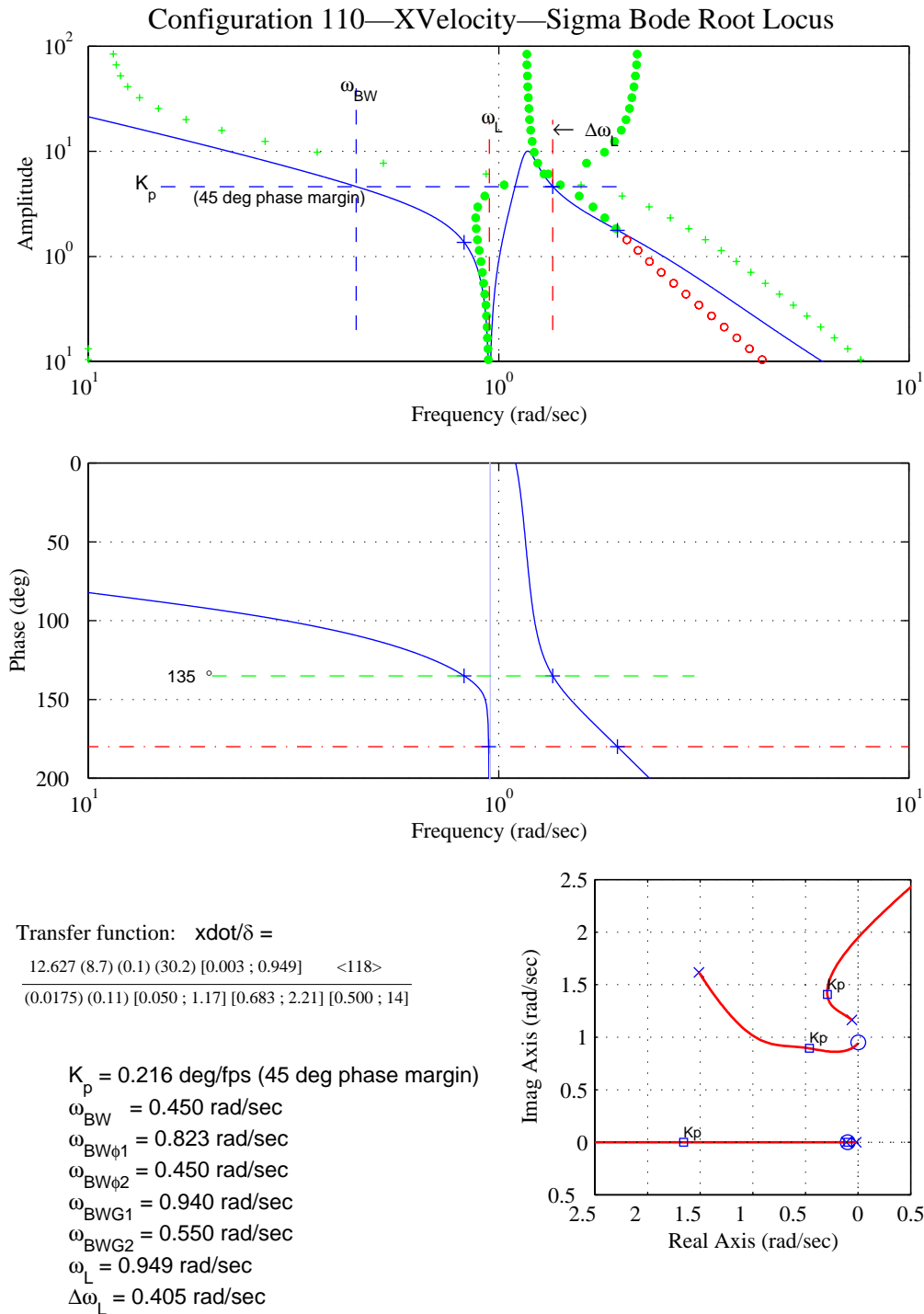
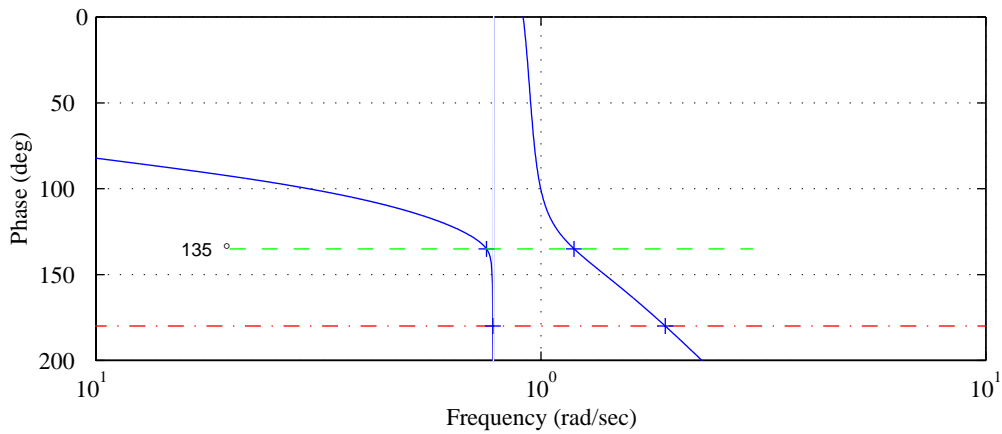
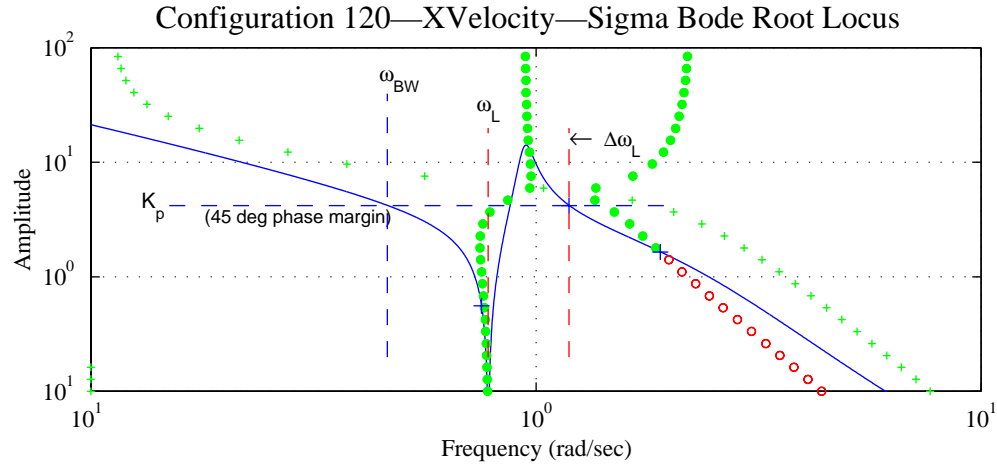

Figure D-3. Longitudinal Translational-Rate-Loop-Closure Characteristics – Configuration 110.



Transfer function: $\dot{x}/\delta =$
 $\frac{12.627 (8.54) (0.1) (30) [0.002 ; 0.781] \quad <118>}{(0.0175) (0.11) [0.040 ; 0.943] [0.688 ; 2.23] [0.500 ; 14]}$

- $K_p = 0.238 \text{ deg/fps (45 deg phase margin)}$
- $\omega_{BW} = 0.464 \text{ rad/sec}$
- $\omega_{BW\phi1} = 0.755 \text{ rad/sec}$
- $\omega_{BW\phi2} = 0.464 \text{ rad/sec}$
- $\omega_{BWG1} = 0.778 \text{ rad/sec}$
- $\omega_{BWG2} = 0.538 \text{ rad/sec}$
- $\omega_L = 0.781 \text{ rad/sec}$
- $\Delta\omega_L = 0.406 \text{ rad/sec}$

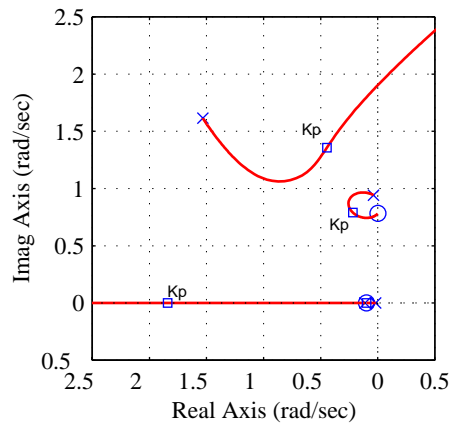
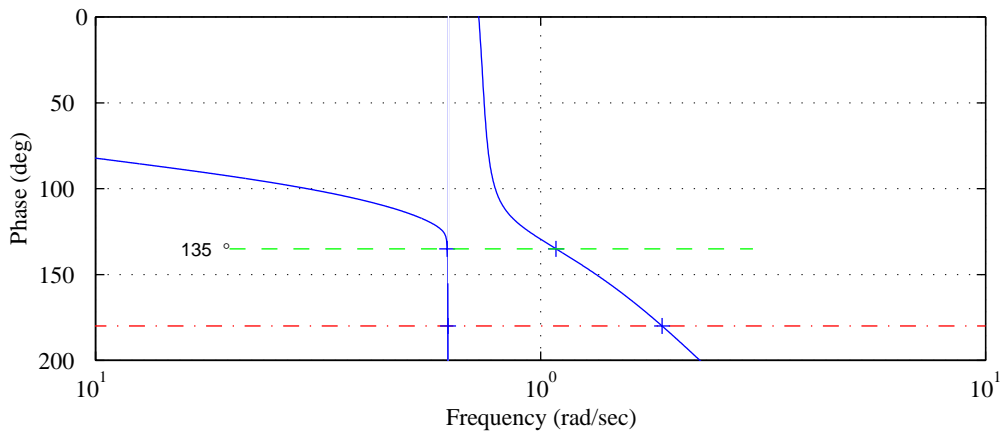
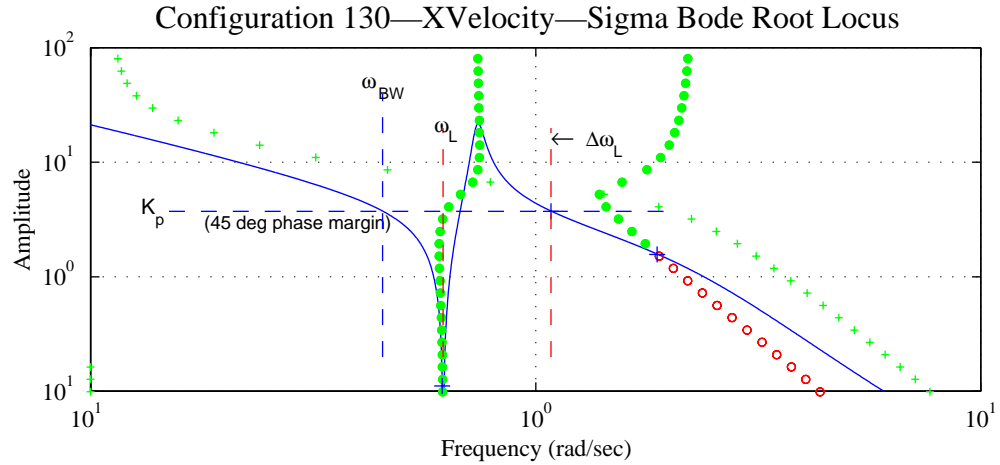

Figure D-4. Longitudinal Translational-Rate-Loop-Closure Characteristics – Configuration 120.



Transfer function: $\dot{x}/\delta =$
 $\frac{12.627 (8.43) (0.1) (29.9) [0.001 ; 0.62] <118>}{(0.0175) (0.11) [0.030 ; 0.74] [0.693 ; 2.23] [0.500 ; 14]}$

- $K_p = 0.267 \text{ deg/fps (45 deg phase margin)}$
- $\omega_{BW} = 0.453 \text{ rad/sec}$
- $\omega_{BW\phi_1} = 0.617 \text{ rad/sec}$
- $\omega_{BW\phi_2} = 0.453 \text{ rad/sec}$
- $\omega_{BWG_1} = 0.618 \text{ rad/sec}$
- $\omega_{BWG_2} = 0.487 \text{ rad/sec}$
- $\omega_L = 0.620 \text{ rad/sec}$
- $\Delta\omega_L = 0.463 \text{ rad/sec}$

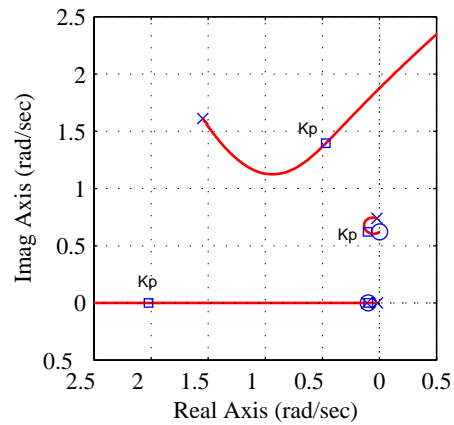

Figure D-5. Longitudinal Translational-Rate-Loop-Closure Characteristics – Configuration 130.

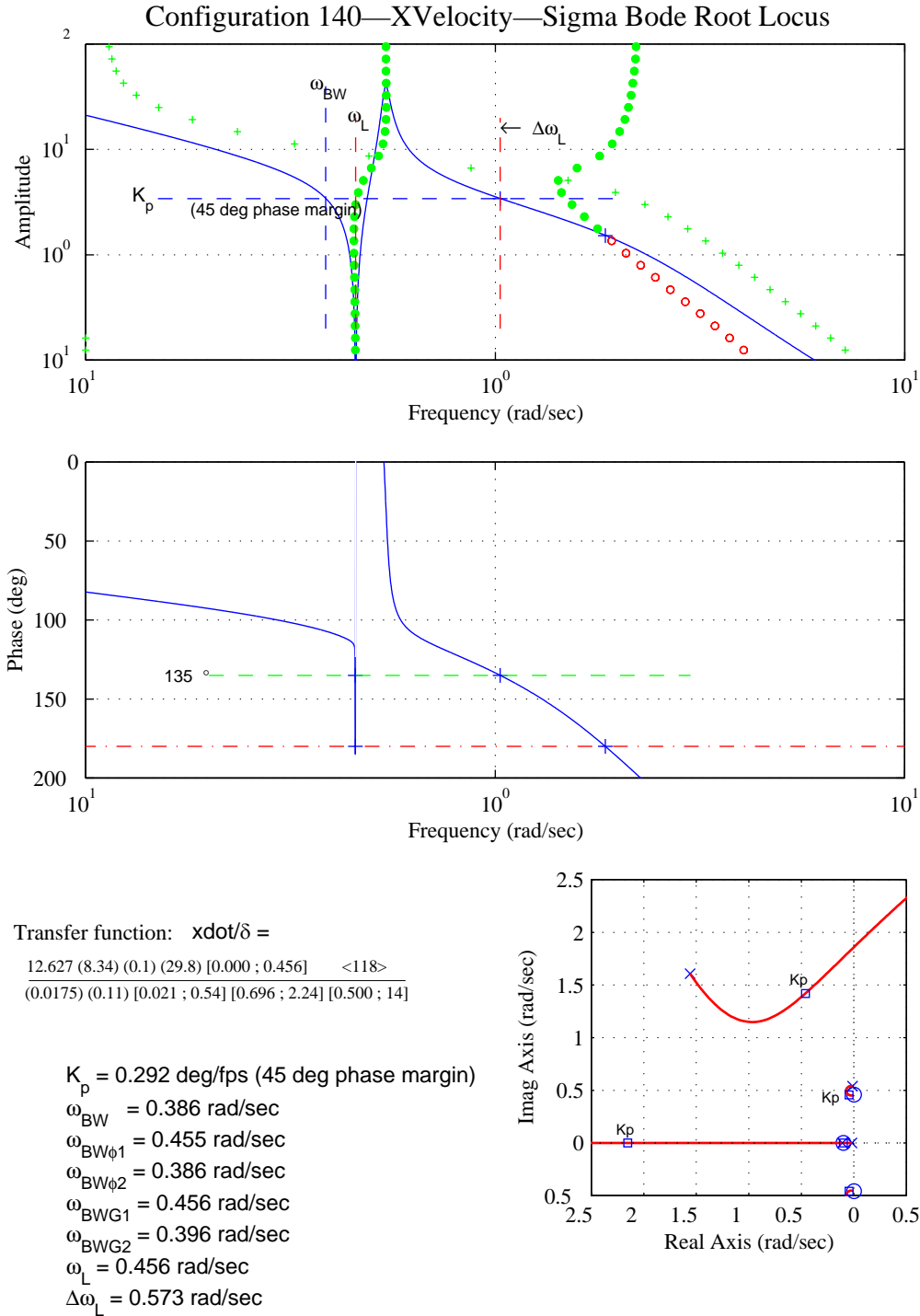
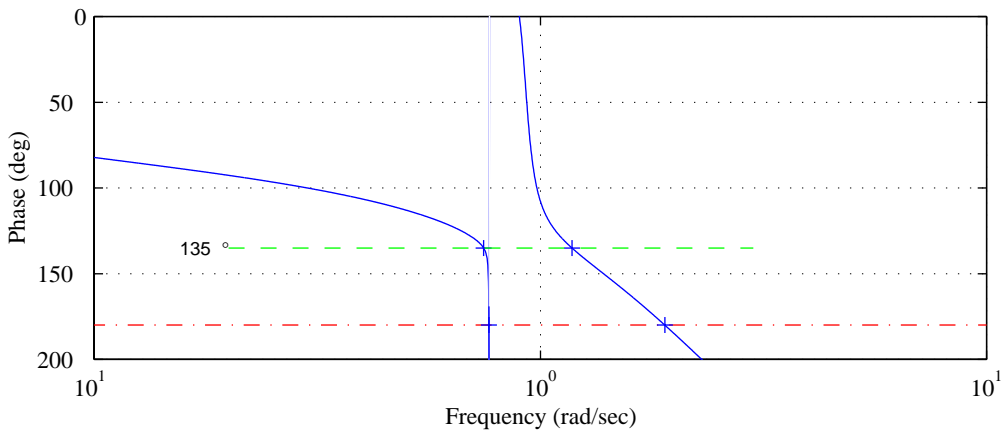
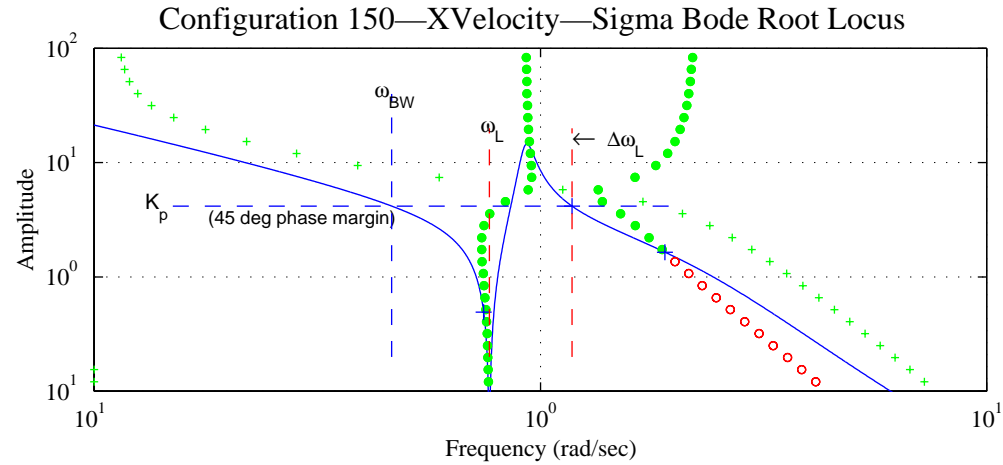

Figure D-6. Longitudinal Translational-Rate-Loop-Closure Characteristics – Configuration 140.



Transfer function: $\dot{x}/\delta =$

$$\frac{12.627 (8.53) (0.1) (30) [0.001 ; 0.768] \quad <118>}{(0.0175) (0.11) [0.039 ; 0.926] [0.689 ; 2.23] [0.500 ; 14]}$$

- $K_p = 0.240$ deg/fps (45 deg phase margin)
- $\omega_{BW} = 0.464$ rad/sec
- $\omega_{BW\phi1} = 0.746$ rad/sec
- $\omega_{BW\phi2} = 0.464$ rad/sec
- $\omega_{BWG1} = 0.765$ rad/sec
- $\omega_{BWG2} = 0.535$ rad/sec
- $\omega_L = 0.768$ rad/sec
- $\Delta\omega_L = 0.409$ rad/sec

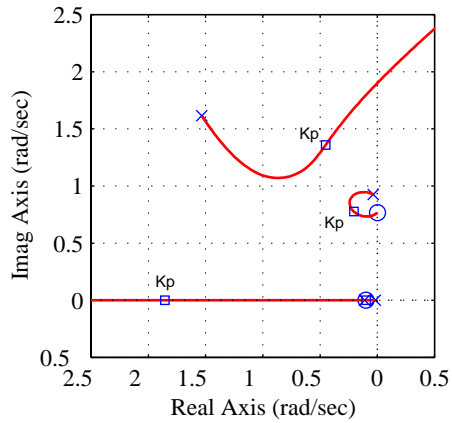

Figure D-7. Longitudinal Translational-Rate-Loop-Closure Characteristics – Configuration 150.

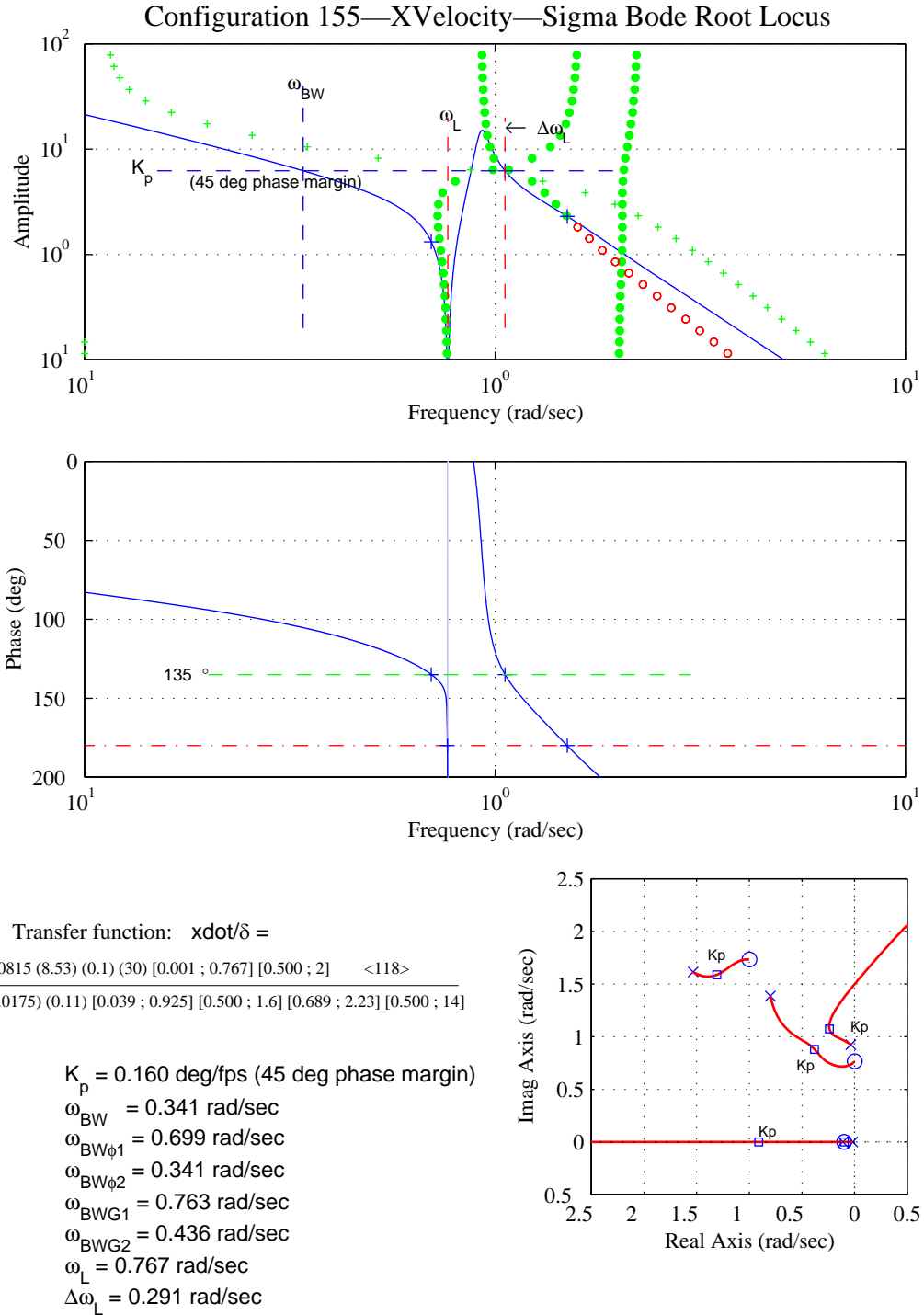

Figure D-8. Longitudinal Translational-Rate-Loop-Closure Characteristics – Configuration 155.

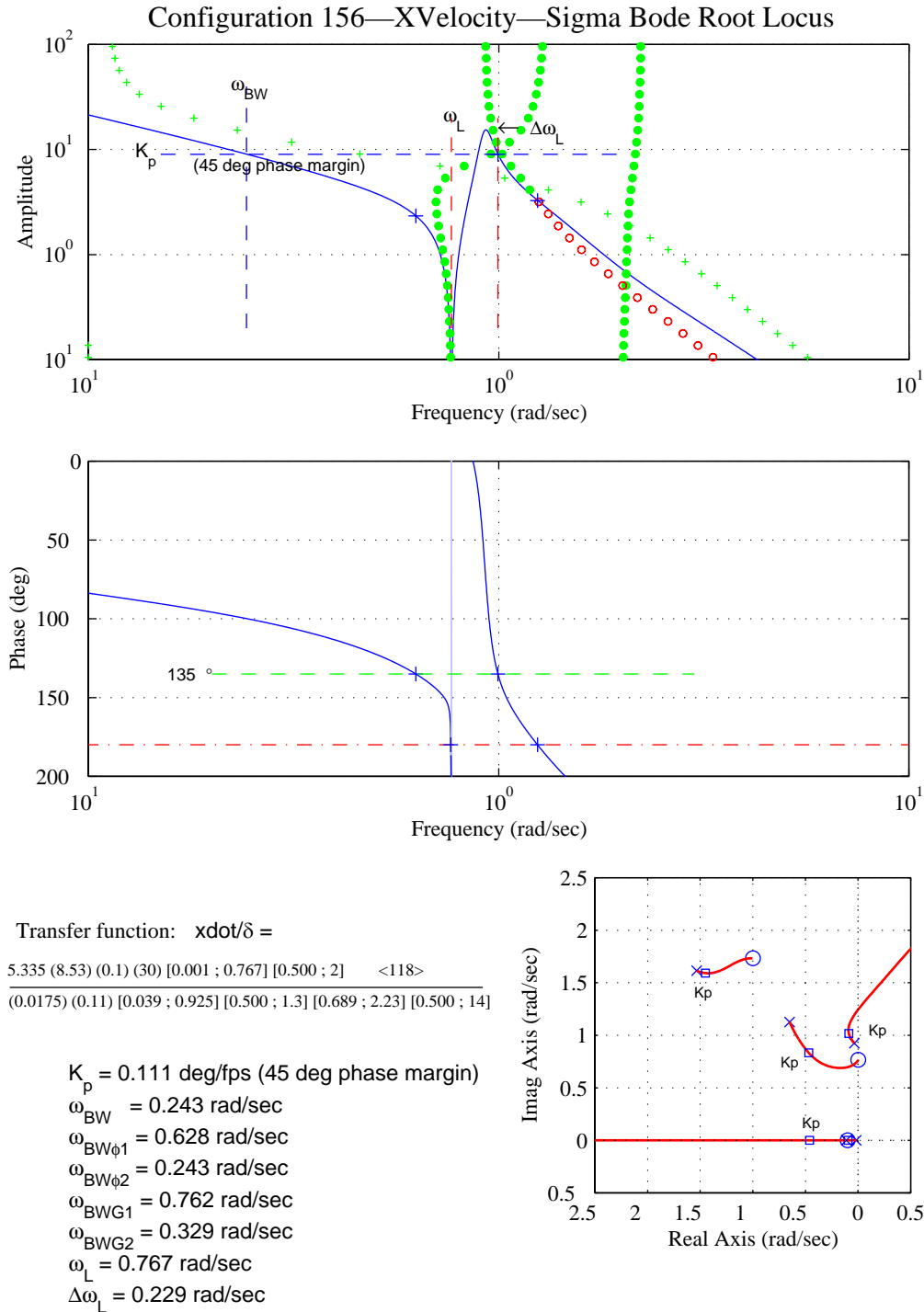

Figure D-9. Longitudinal Translational-Rate-Loop-Closure Characteristics – Configuration 156.

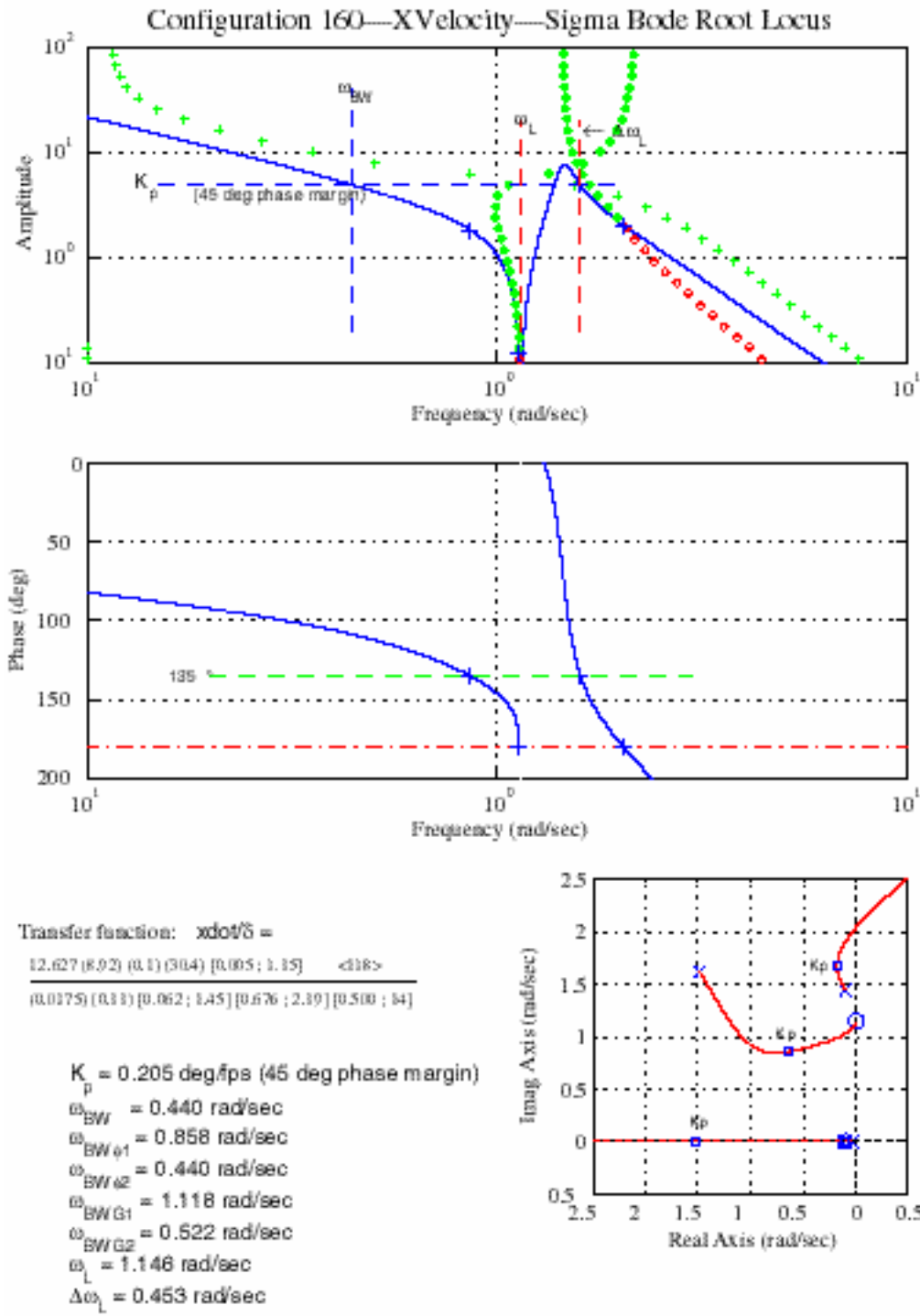

Figure D-10. Longitudinal Translational-Rate-Loop-Closure Characteristics – Configuration 160.

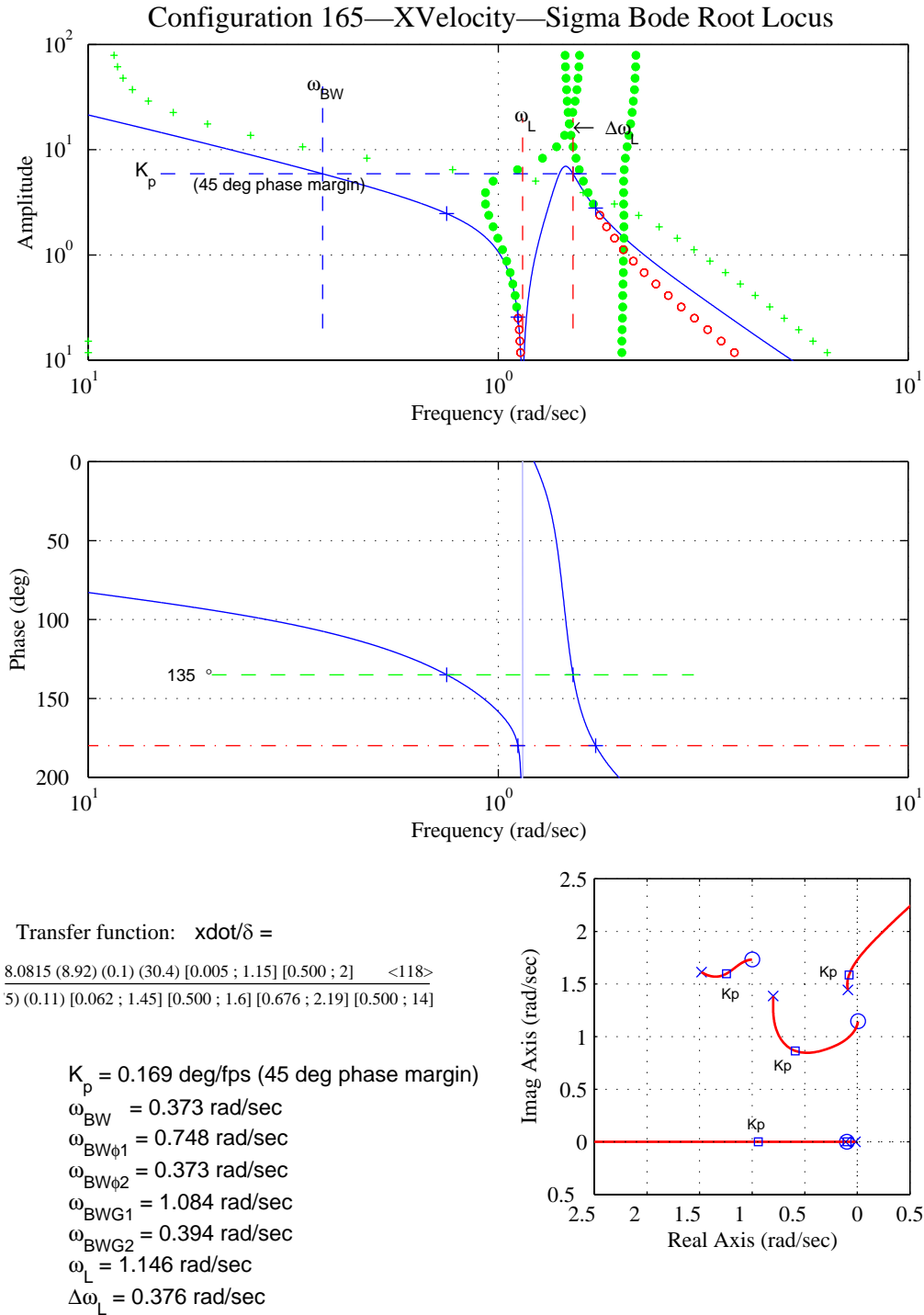
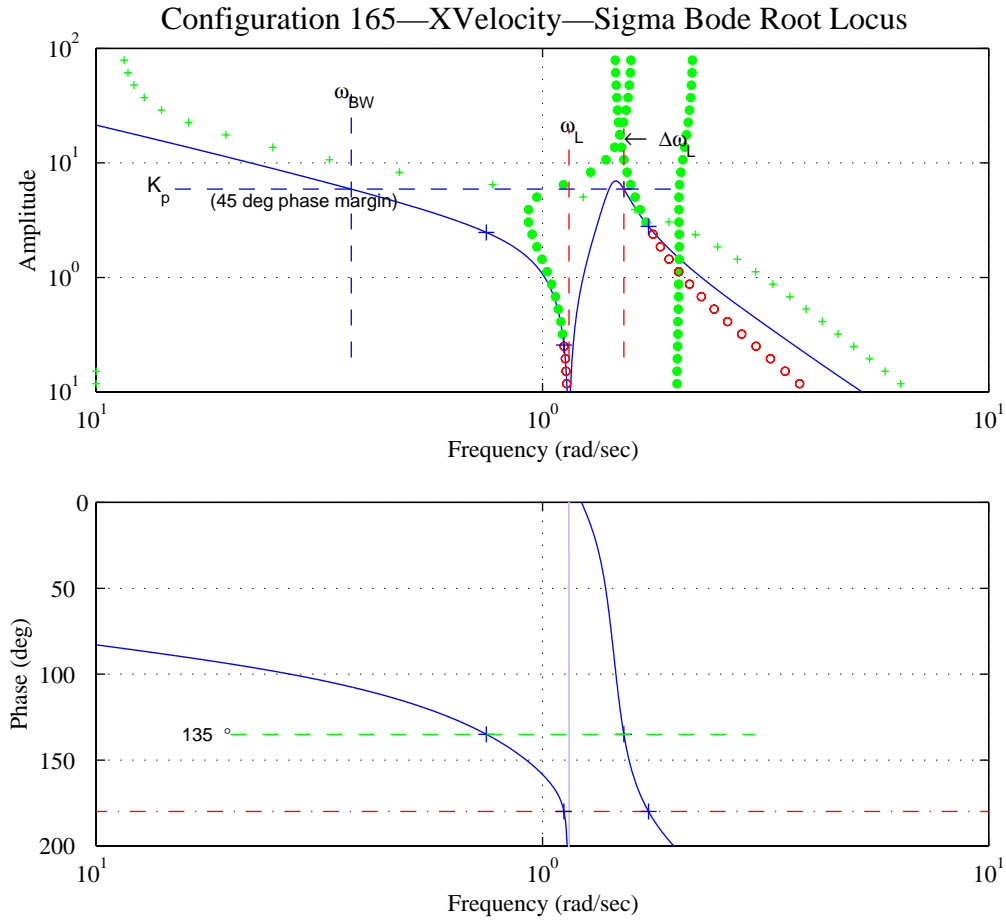

Figure D-11. Longitudinal Translational-Rate-Loop-Closure Characteristics – Configuration 165.



Transfer function: $\dot{x}/\delta =$
 $\frac{8.0815 (8.92) (0.1) (30.4) [0.005 ; 1.15] [0.500 ; 2] \quad <118>}{5) (0.11) [0.062 ; 1.45] [0.500 ; 1.6] [0.676 ; 2.19] [0.500 ; 14]}$

- $K_p = 0.169 \text{ deg/fps (45 deg phase margin)}$
- $\omega_{BW} = 0.373 \text{ rad/sec}$
- $\omega_{BW\phi_1} = 0.748 \text{ rad/sec}$
- $\omega_{BW\phi_2} = 0.373 \text{ rad/sec}$
- $\omega_{BWG_1} = 1.084 \text{ rad/sec}$
- $\omega_{BWG_2} = 0.394 \text{ rad/sec}$
- $\omega_L = 1.146 \text{ rad/sec}$
- $\Delta\omega_L = 0.376 \text{ rad/sec}$

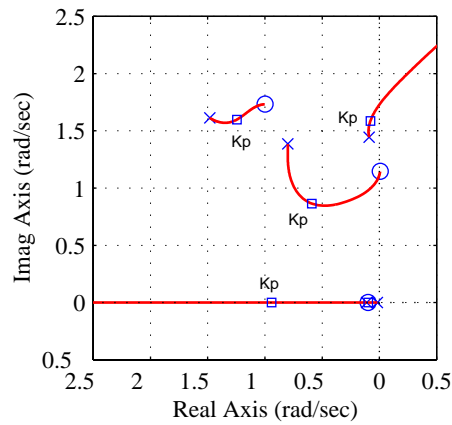
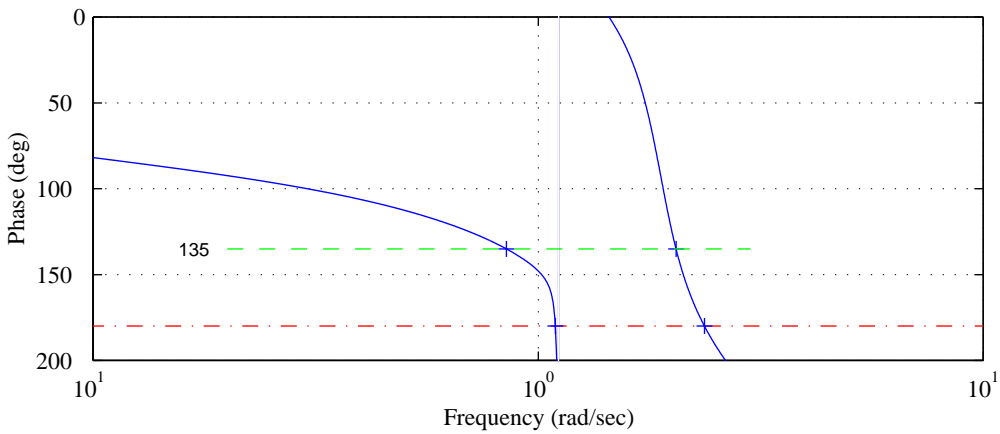
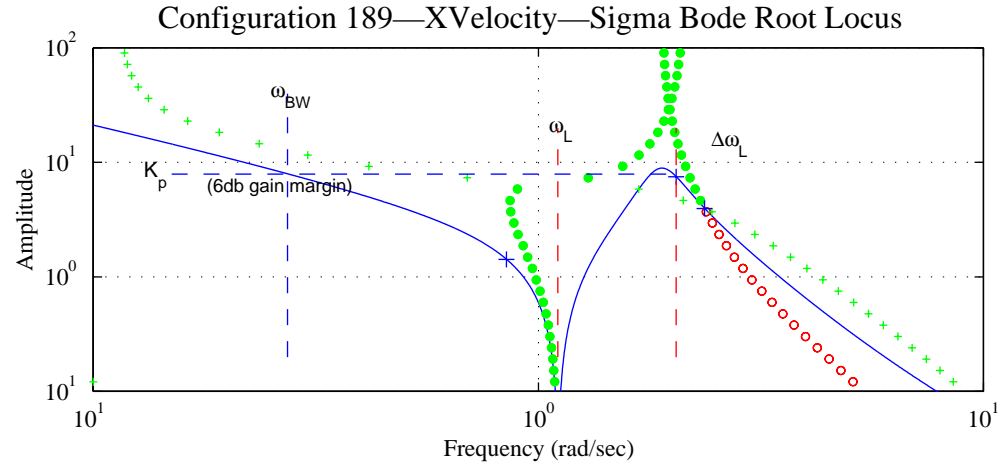

Figure D-12. Longitudinal Translational-Rate-Loop-Closure Characteristics – Configuration 166.



Transfer function: $\dot{x}/\delta =$
 $\frac{19.841 (9.48) (0.1) (31.8) [0.008 ; 1.11] \quad <118>}{(0.0172) (0.113) [0.118 ; 1.89] [0.634 ; 2.14] [0.500 ; 14]}$

$K_p = 0.126 \text{ deg/fps (6db gain margin)}$
 $\omega_{BW} = 0.273 \text{ rad/sec}$
 $\omega_{BW\phi_1} = 0.848 \text{ rad/sec}$
 $\omega_{BW\phi_2} = 0.288 \text{ rad/sec}$
 $\omega_{BWG_1} = 1.074 \text{ rad/sec}$
 $\omega_{BWG_2} = 0.273 \text{ rad/sec}$
 $\omega_L = 1.107 \text{ rad/sec}$
 $\Delta\omega_L = 0.933 \text{ rad/sec}$

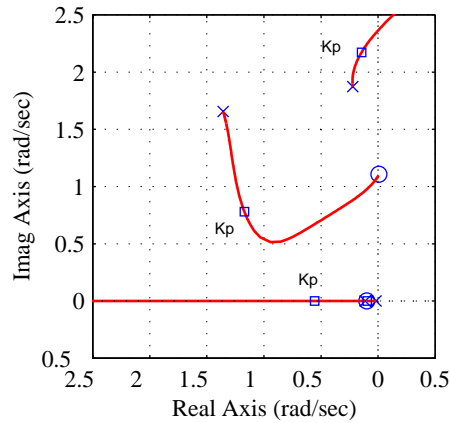

Figure D-13. Longitudinal Translational-Rate-Loop-Closure Characteristics – Configuration 189.

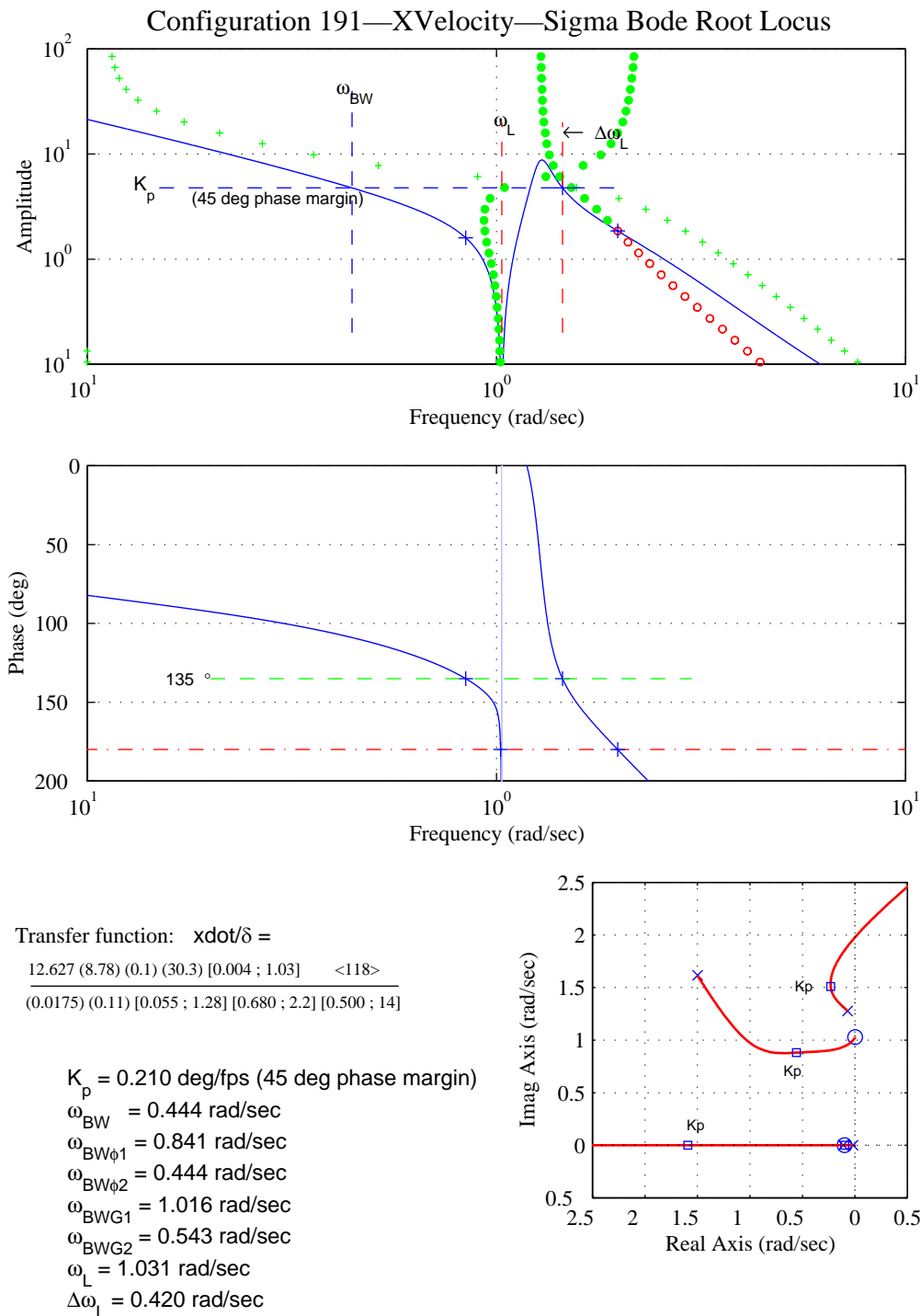

Figure D-14. Longitudinal Translational-Rate-Loop-Closure Characteristics – Configuration 191.

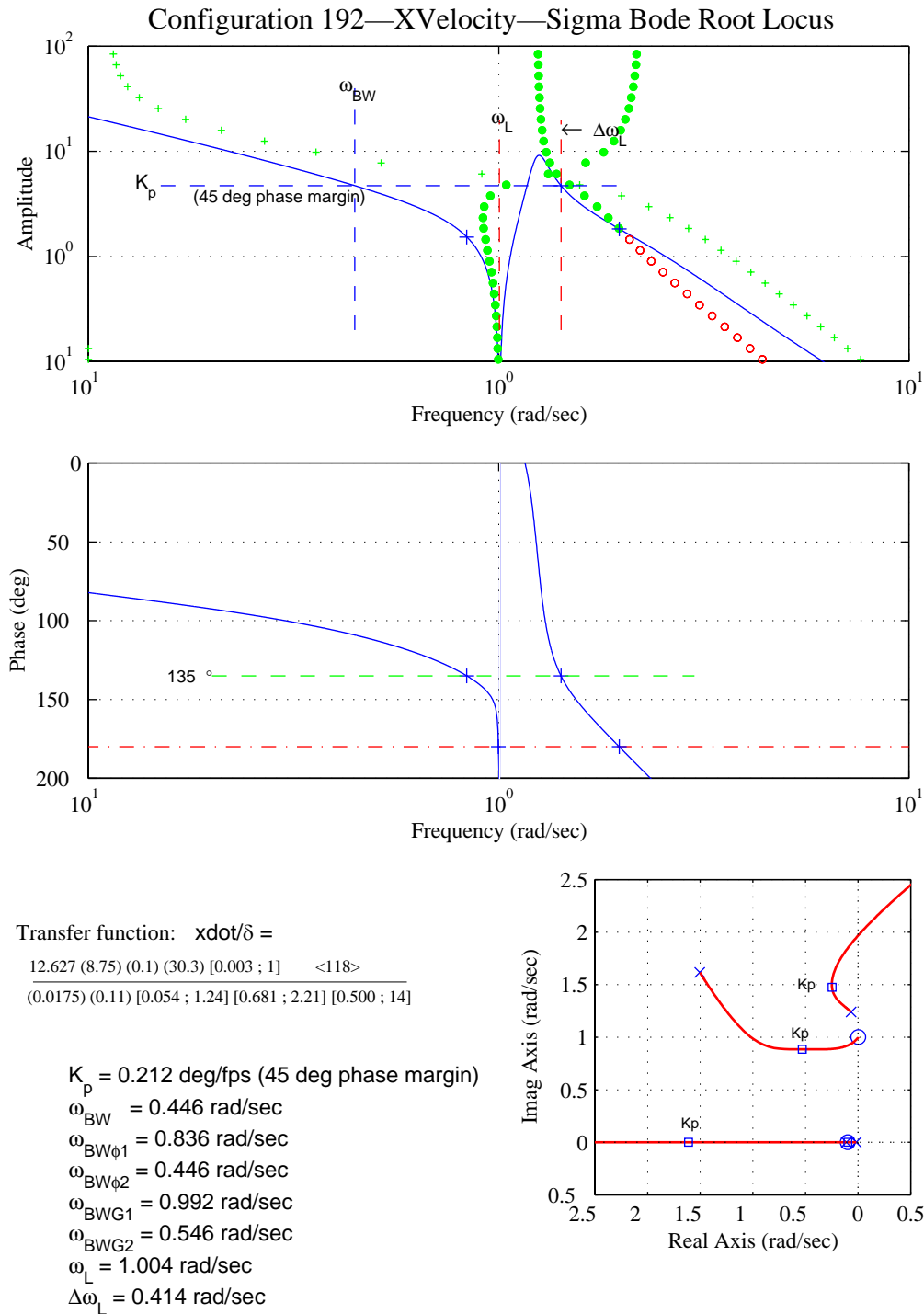

Figure D-15. Longitudinal Translational-Rate-Loop-Closure Characteristics – Configuration 192.

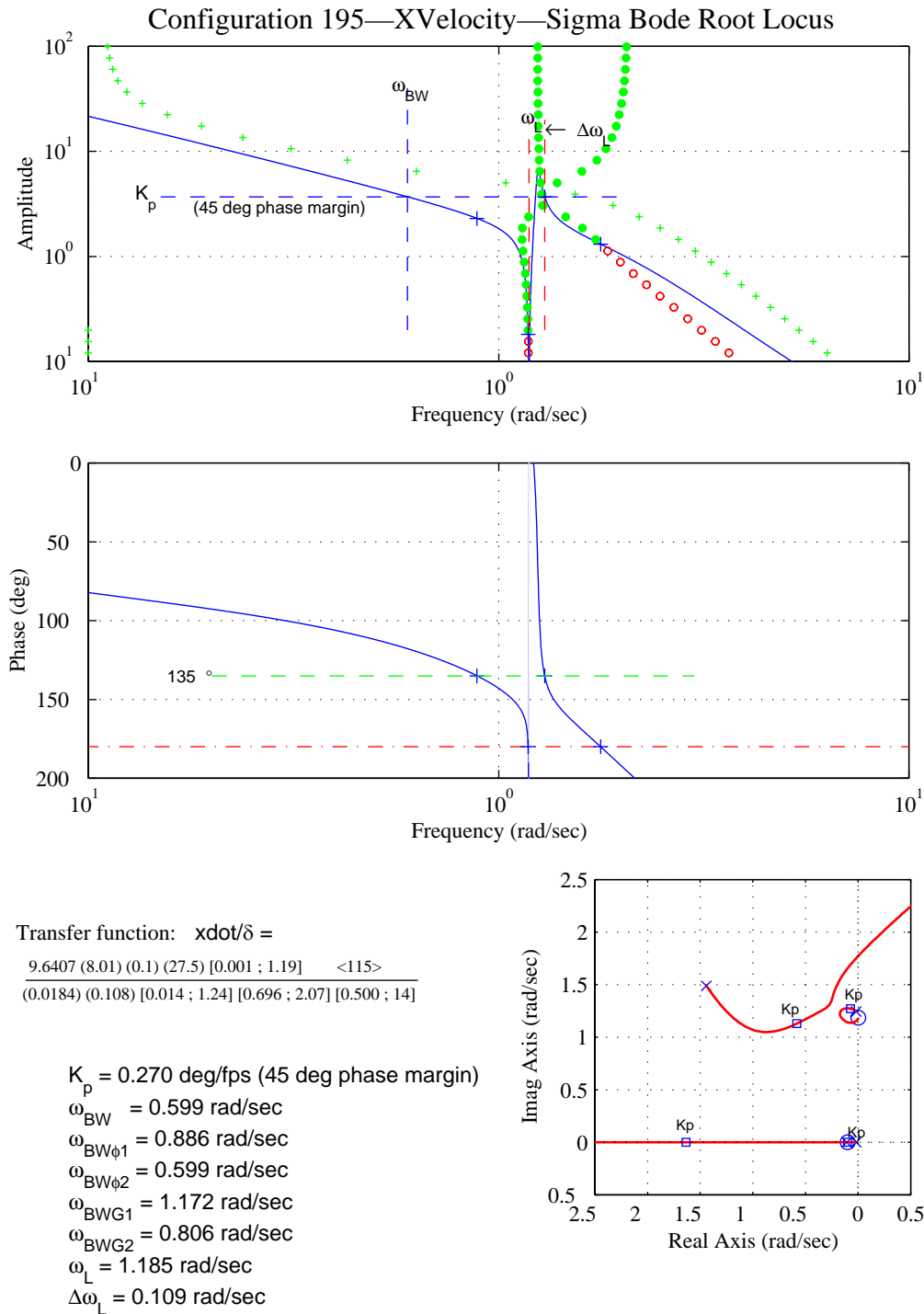

Figure D-16. Longitudinal Translational-Rate-Loop-Closure Characteristics – Configuration 195.

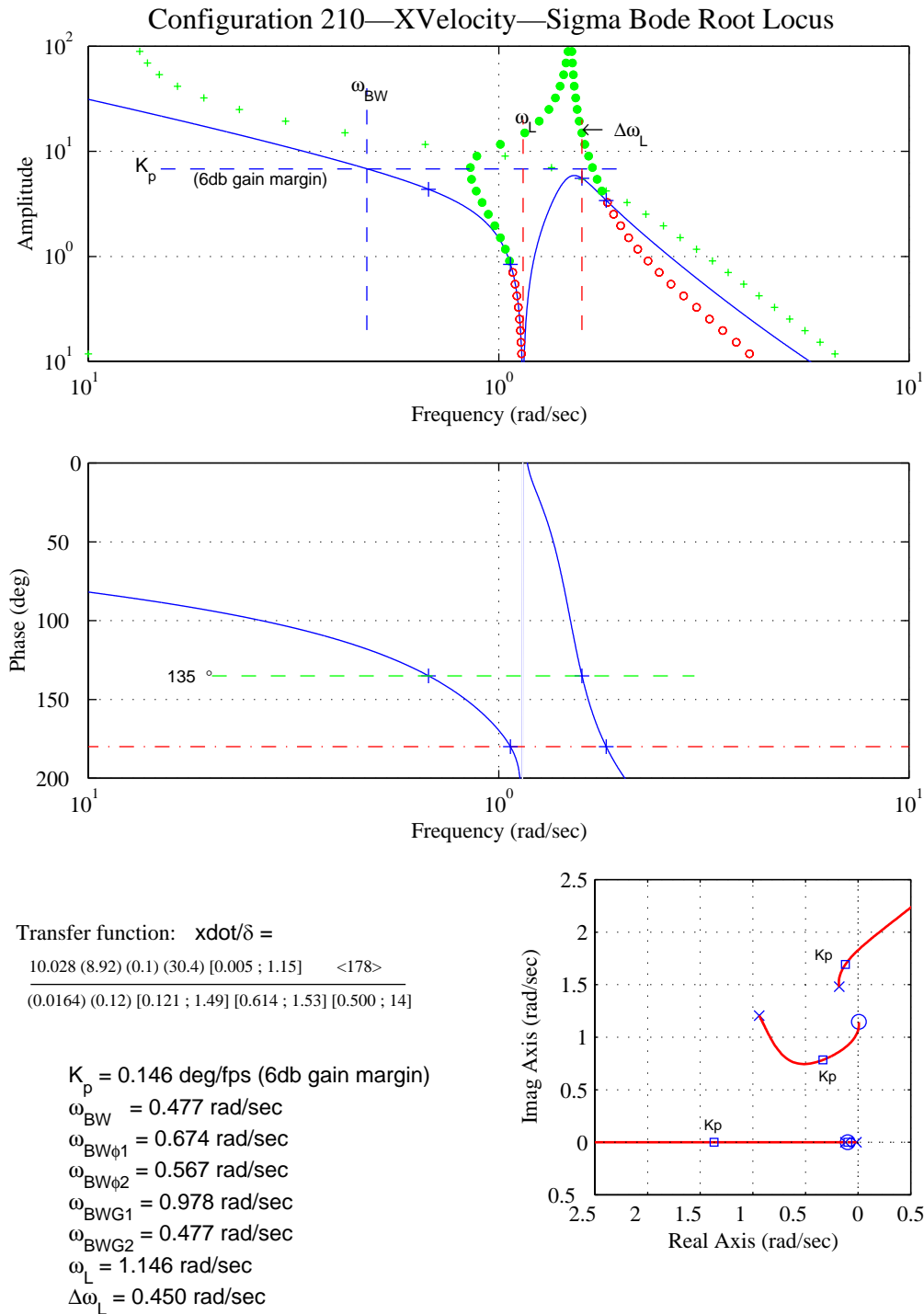

Figure D-17. Longitudinal Translational-Rate-Loop-Closure Characteristics – Configuration 210.

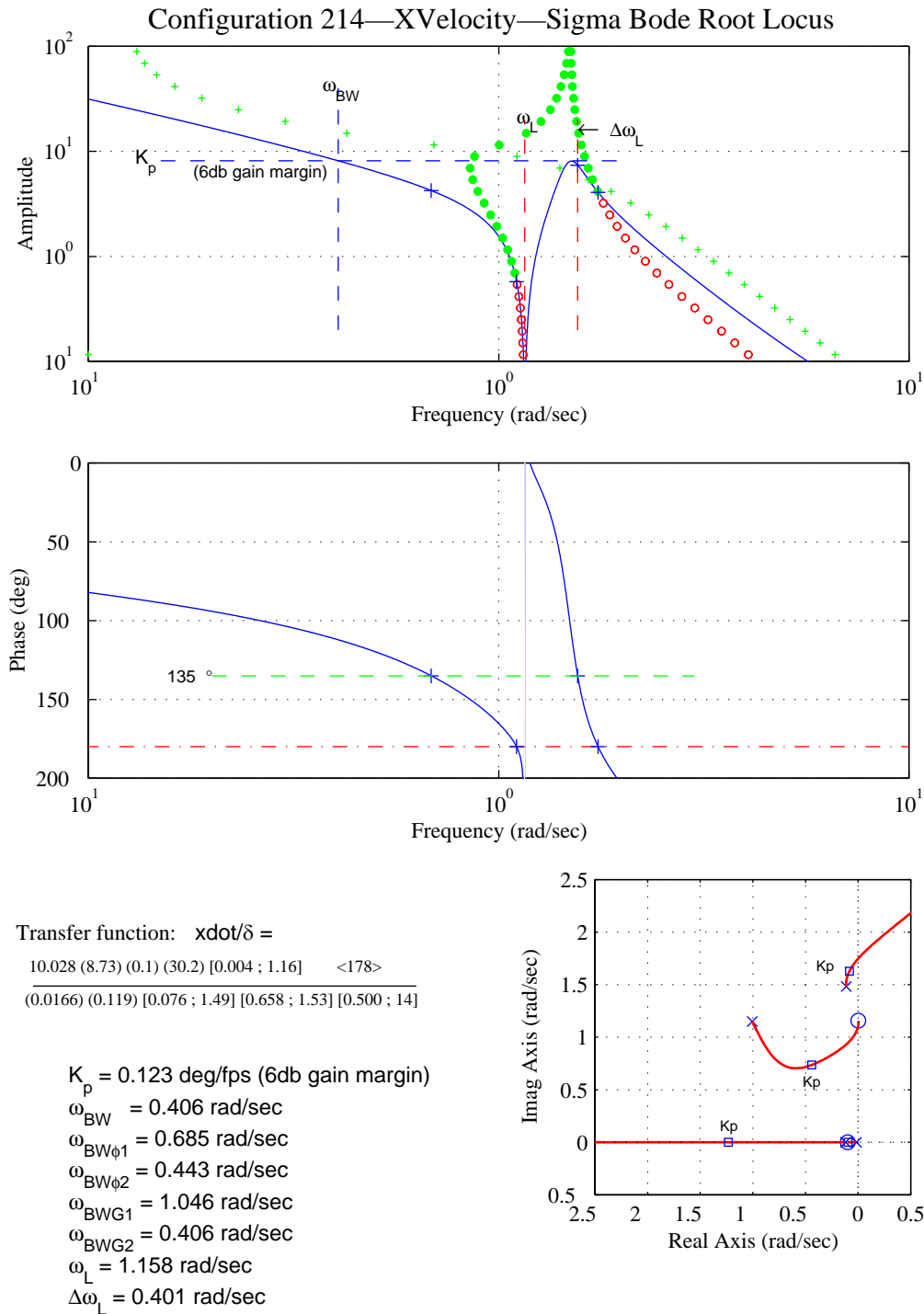

Figure D-18. Longitudinal Translational-Rate-Loop-Closure Characteristics – Configuration 214.

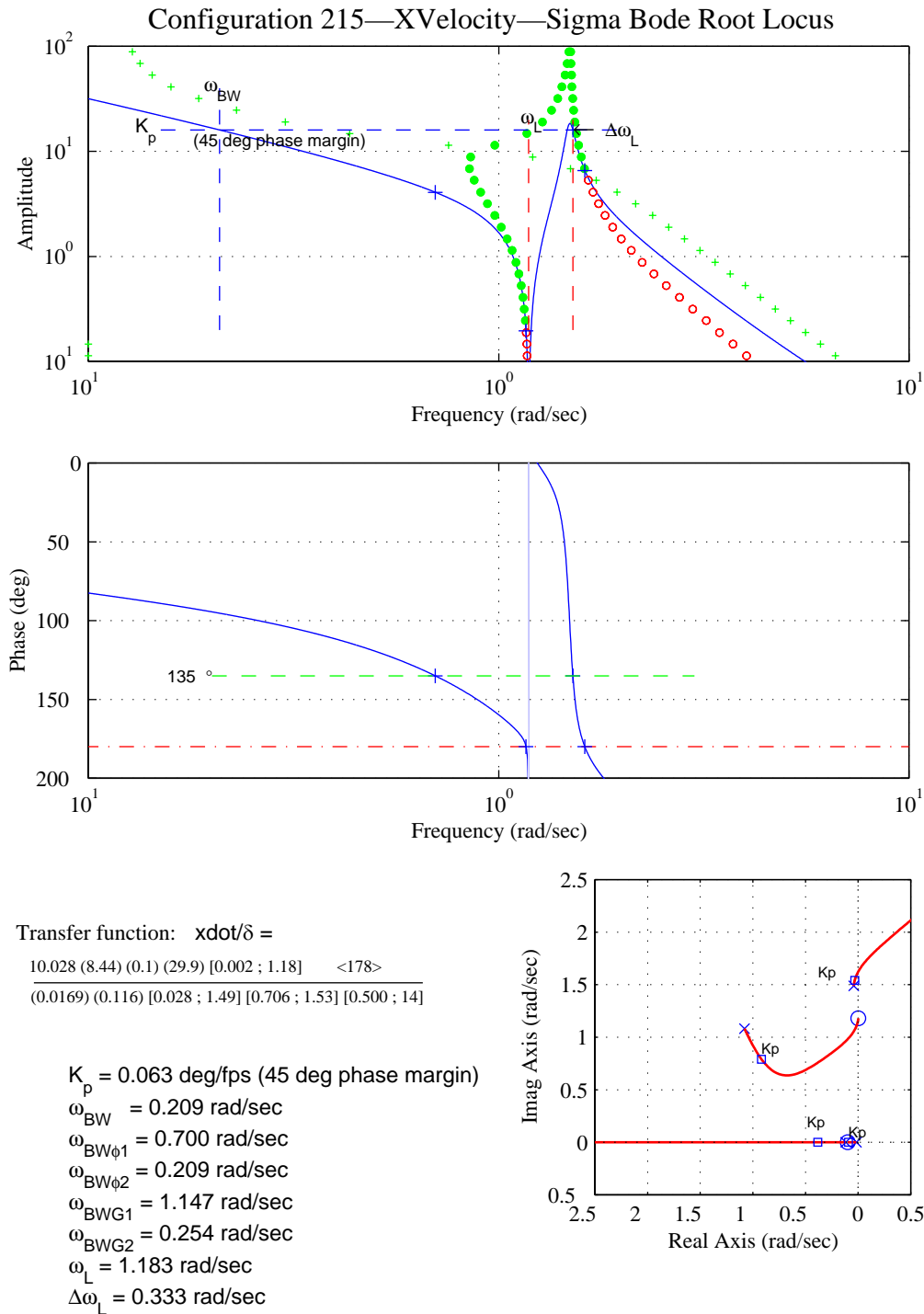
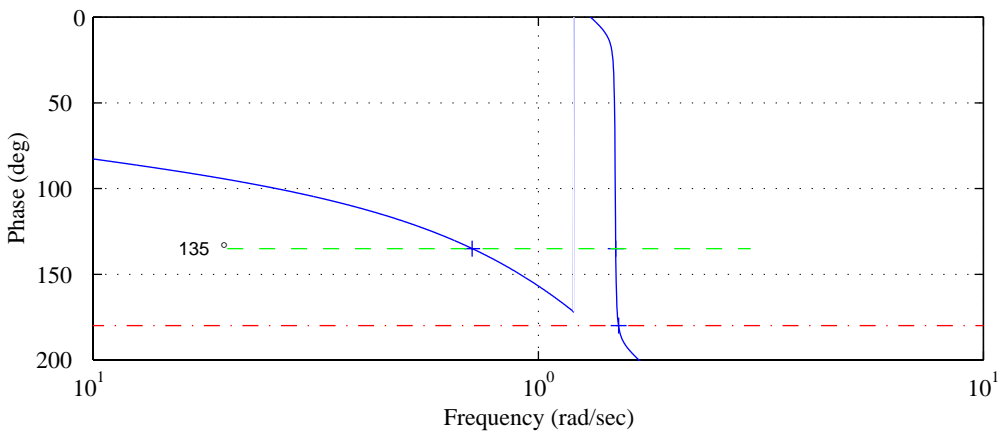
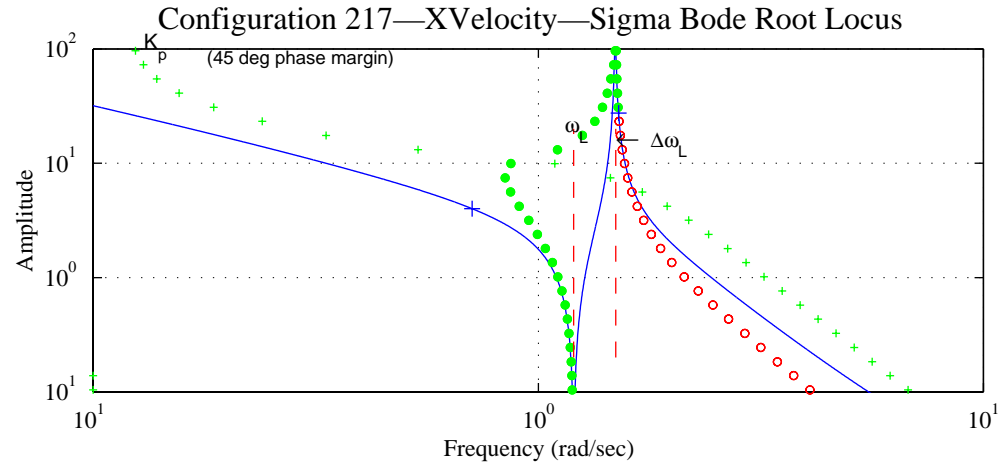

Figure D-19. Longitudinal Translational-Rate-Loop-Closure Characteristics – Configuration 215.



Transfer function: $\dot{x}/\delta =$
 $\frac{10.028 (8.25) (0.1) (29.7) [0.000 ; 1.2] <178>}{(0.0171) (0.115) [0.004 ; 1.49] [0.730 ; 1.53] [0.500 ; 14]}$

$K_p = 0.009 \text{ deg/fps (45 deg phase margin)}$
 $\omega_{BW} = 0.023 \text{ rad/sec}$
 $\omega_{BW\phi_1} = 0.710 \text{ rad/sec}$
 $\omega_{BW\phi_2} = 0.023 \text{ rad/sec}$
 $\omega_{BWG_1} = 0.054 \text{ rad/sec}$
 $\omega_L = 1.201 \text{ rad/sec}$
 $\Delta\omega_L = 0.292 \text{ rad/sec}$

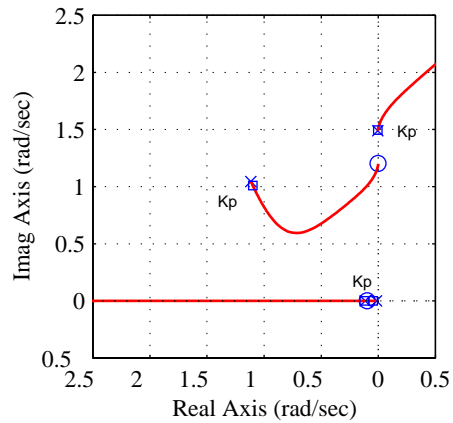

Figure D-20. Longitudinal Translational-Rate-Loop-Closure Characteristics – Configuration 217.

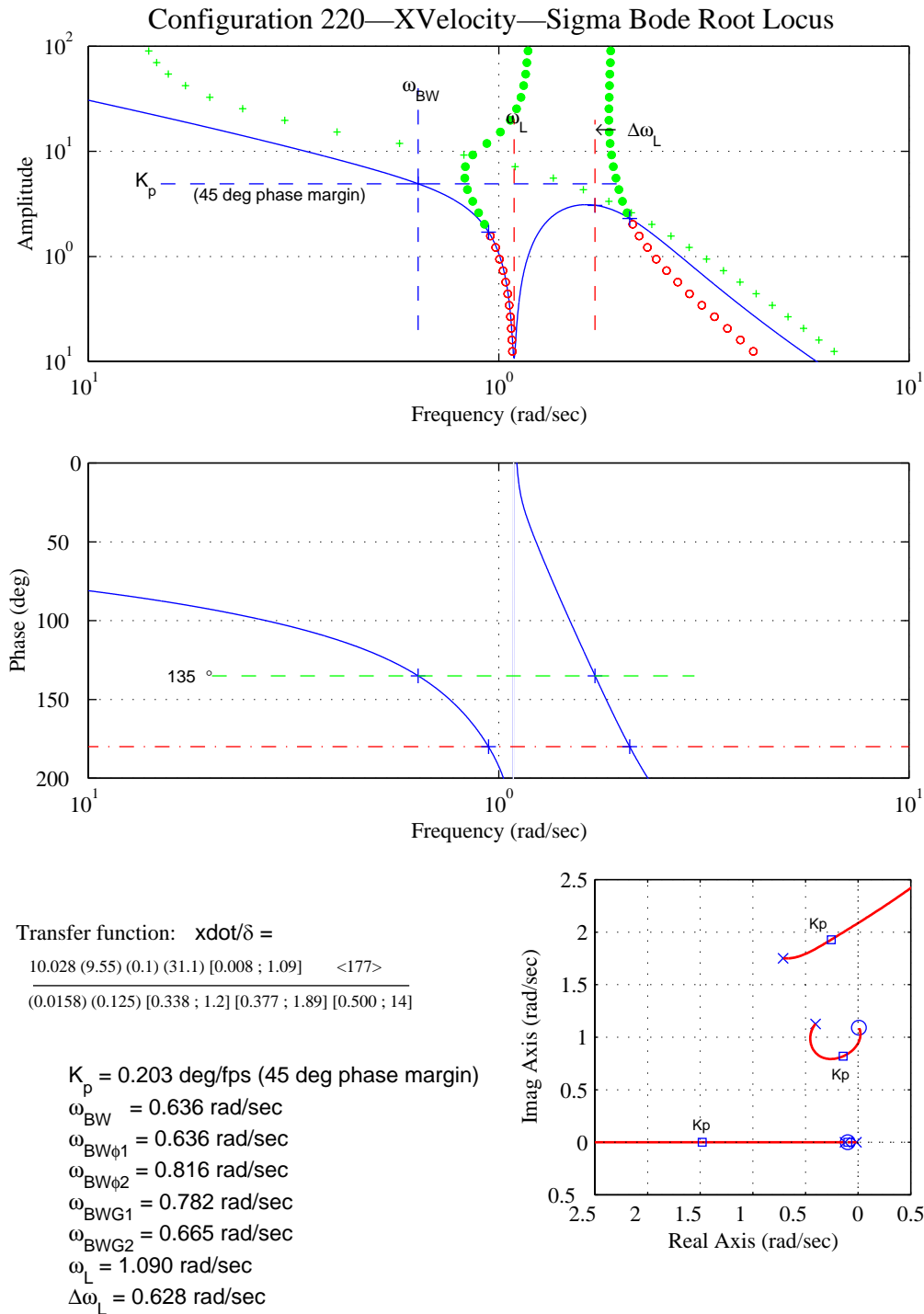

Figure D-21. Longitudinal Translational-Rate-Loop-Closure Characteristics – Configuration 220.

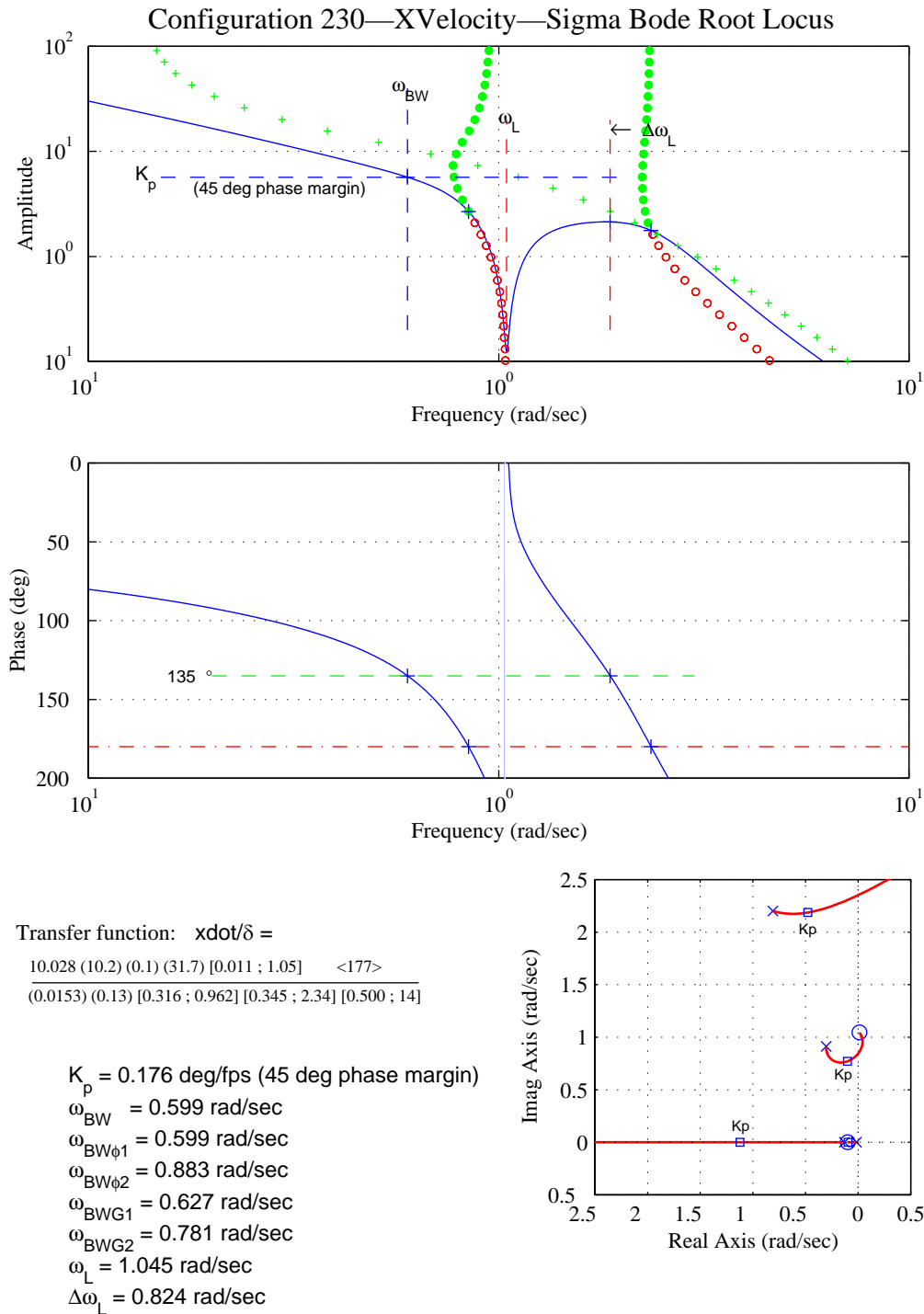

Figure D-22. Longitudinal Translational-Rate-Loop-Closure Characteristics – Configuration 230.

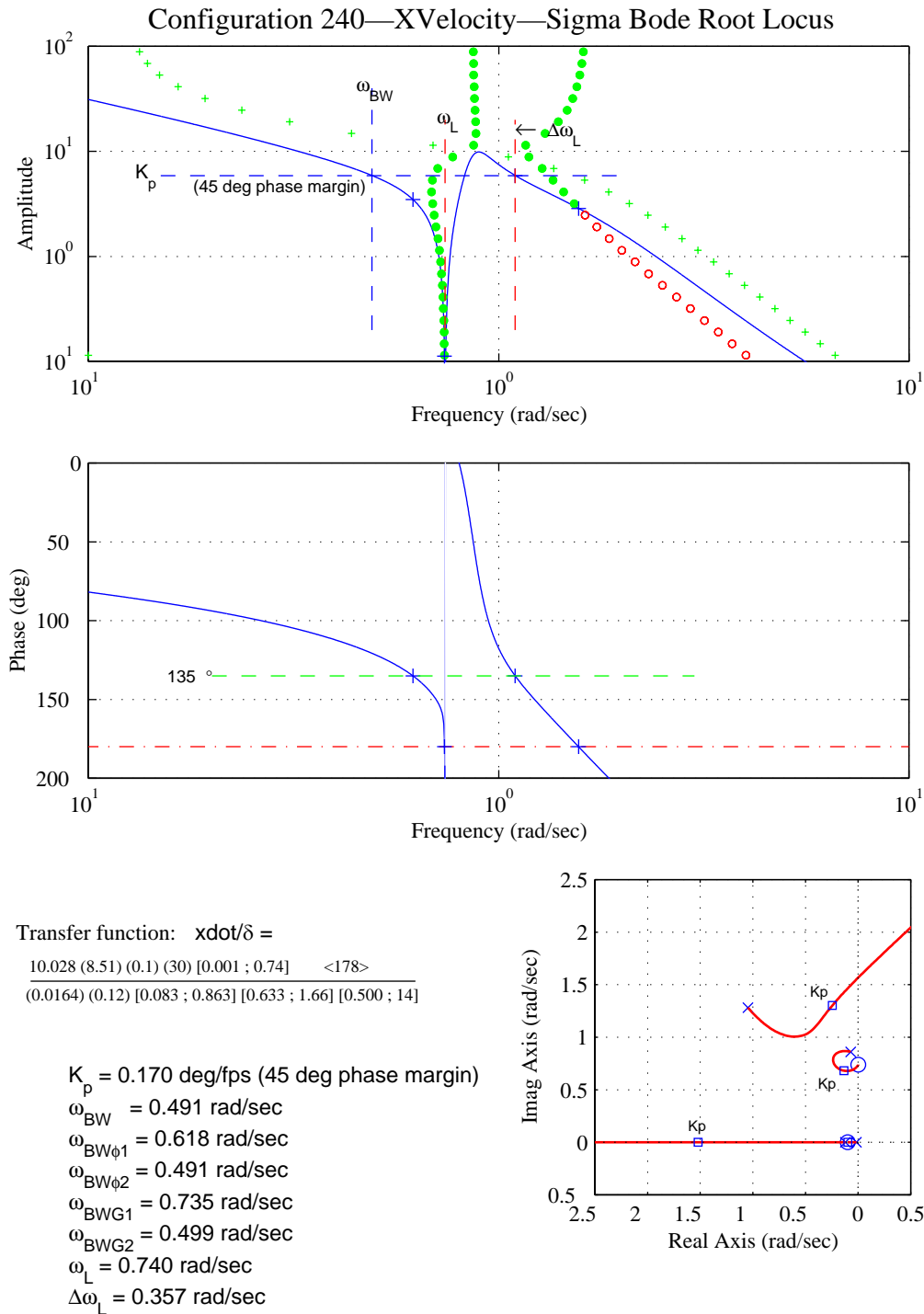
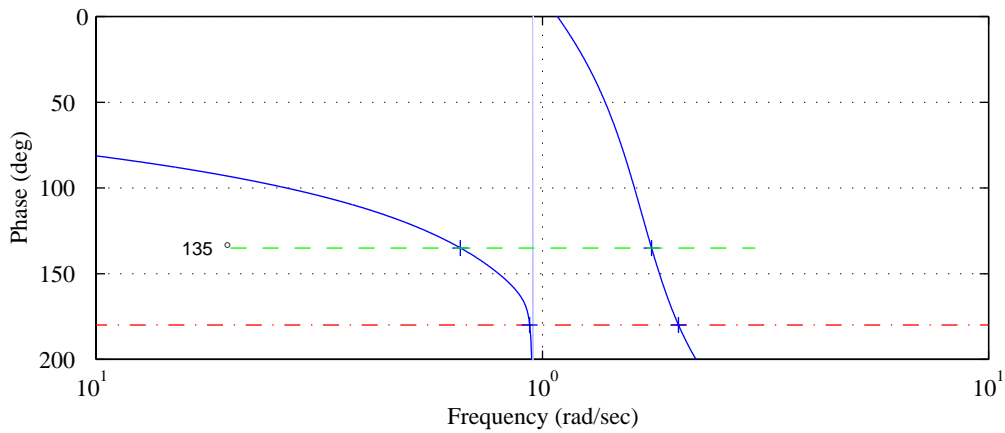
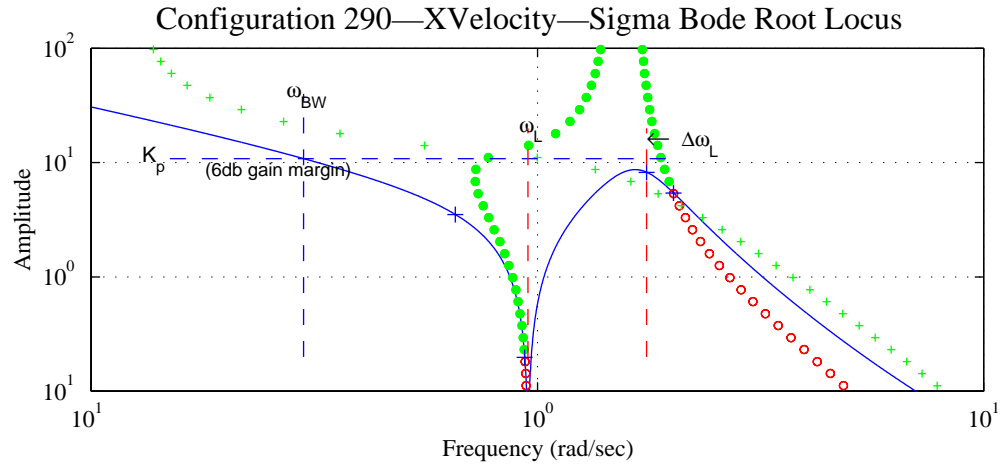

Figure D-23. Longitudinal Translational-Rate-Loop-Closure Characteristics – Configuration 240.



Transfer function: $\dot{x}/\delta =$
 $\frac{15.756 (9.14) (0.1) (31.4) [0.005 ; 0.953] <177>}{(0.016) (0.125) [0.201 ; 1.68] [0.544 ; 1.45] [0.500 ; 14]}$

- $K_p = 0.092 \text{ deg/fps (6db gain margin)}$
- $\omega_{BW} = 0.299 \text{ rad/sec}$
- $\omega_{BW\phi1} = 0.655 \text{ rad/sec}$
- $\omega_{BW\phi2} = 0.381 \text{ rad/sec}$
- $\omega_{BWG1} = 0.920 \text{ rad/sec}$
- $\omega_{BWG2} = 0.299 \text{ rad/sec}$
- $\omega_L = 0.953 \text{ rad/sec}$
- $\Delta\omega_L = 0.804 \text{ rad/sec}$

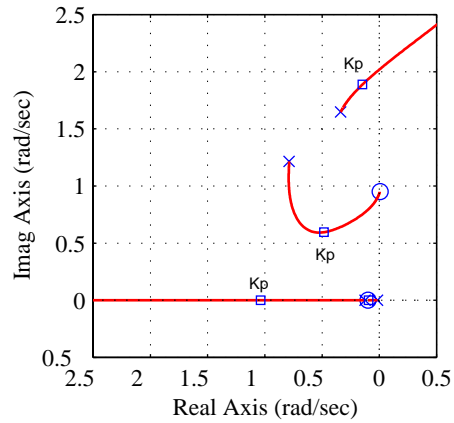

Figure D-24. Longitudinal Translational-Rate-Loop-Closure Characteristics – Configuration 290.

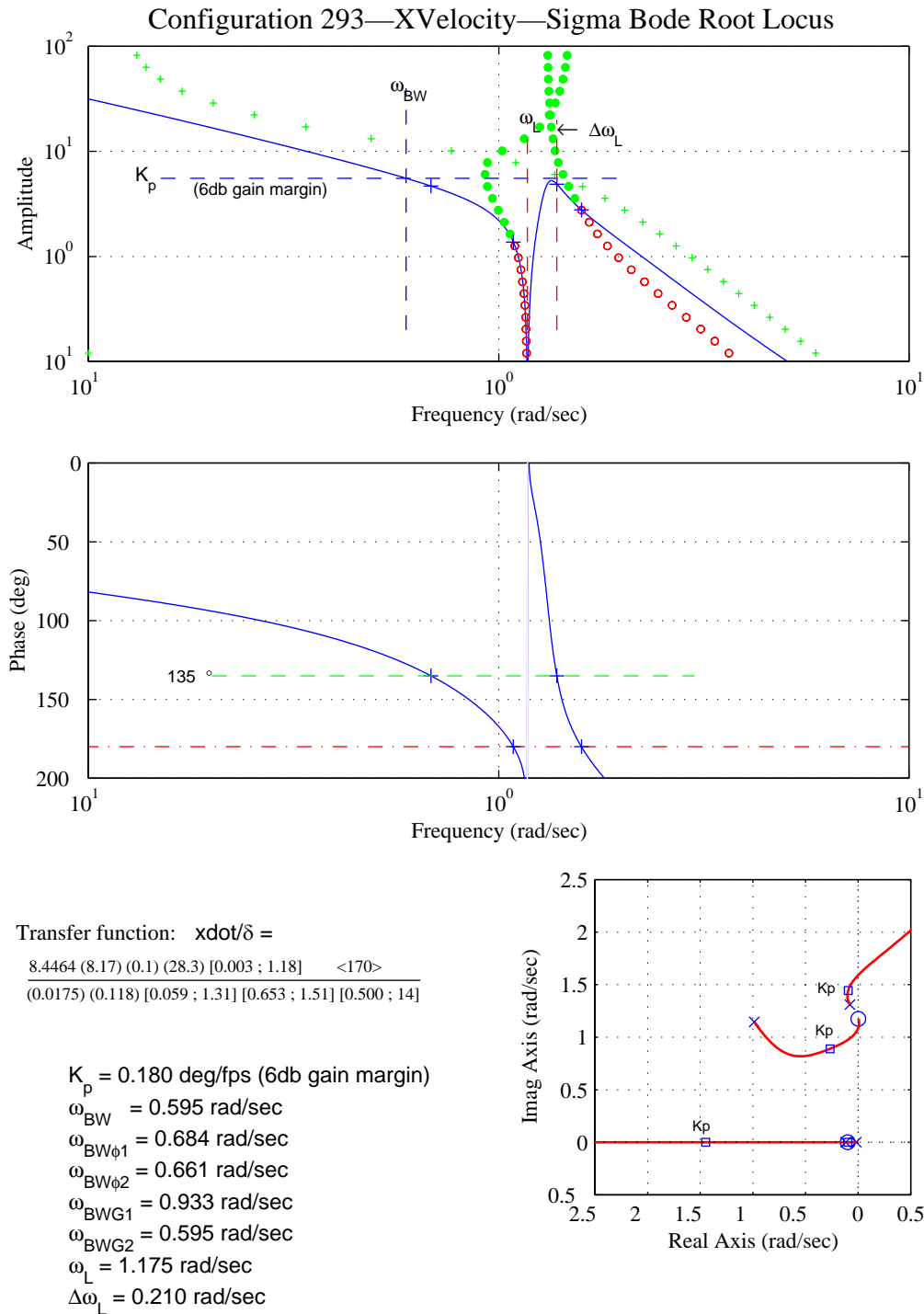

Figure D-25. Longitudinal Translational-Rate-Loop-Closure Characteristics – Configuration 293.

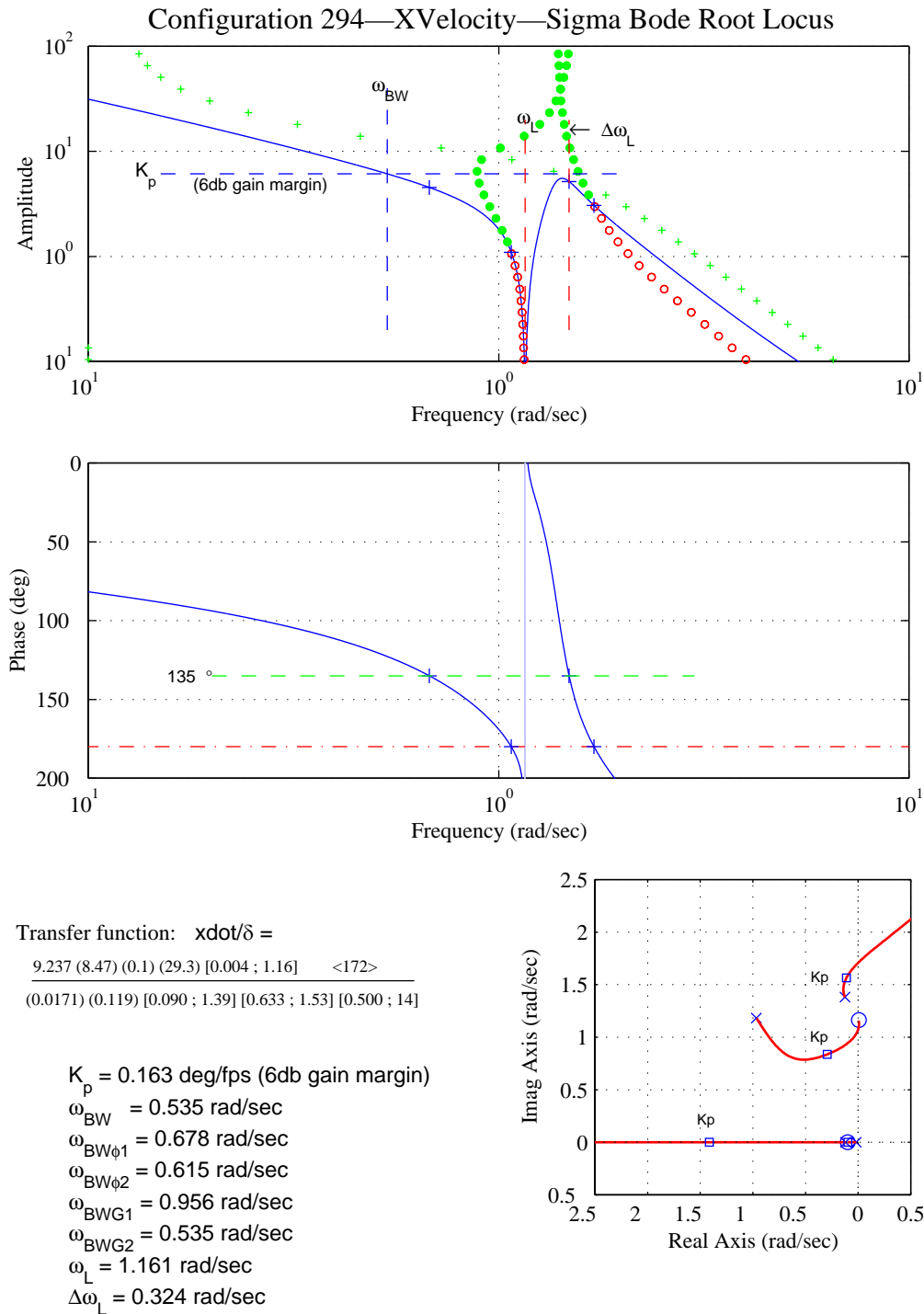

Figure D-26. Longitudinal Translational-Rate-Loop-Closure Characteristics – Configuration 294.

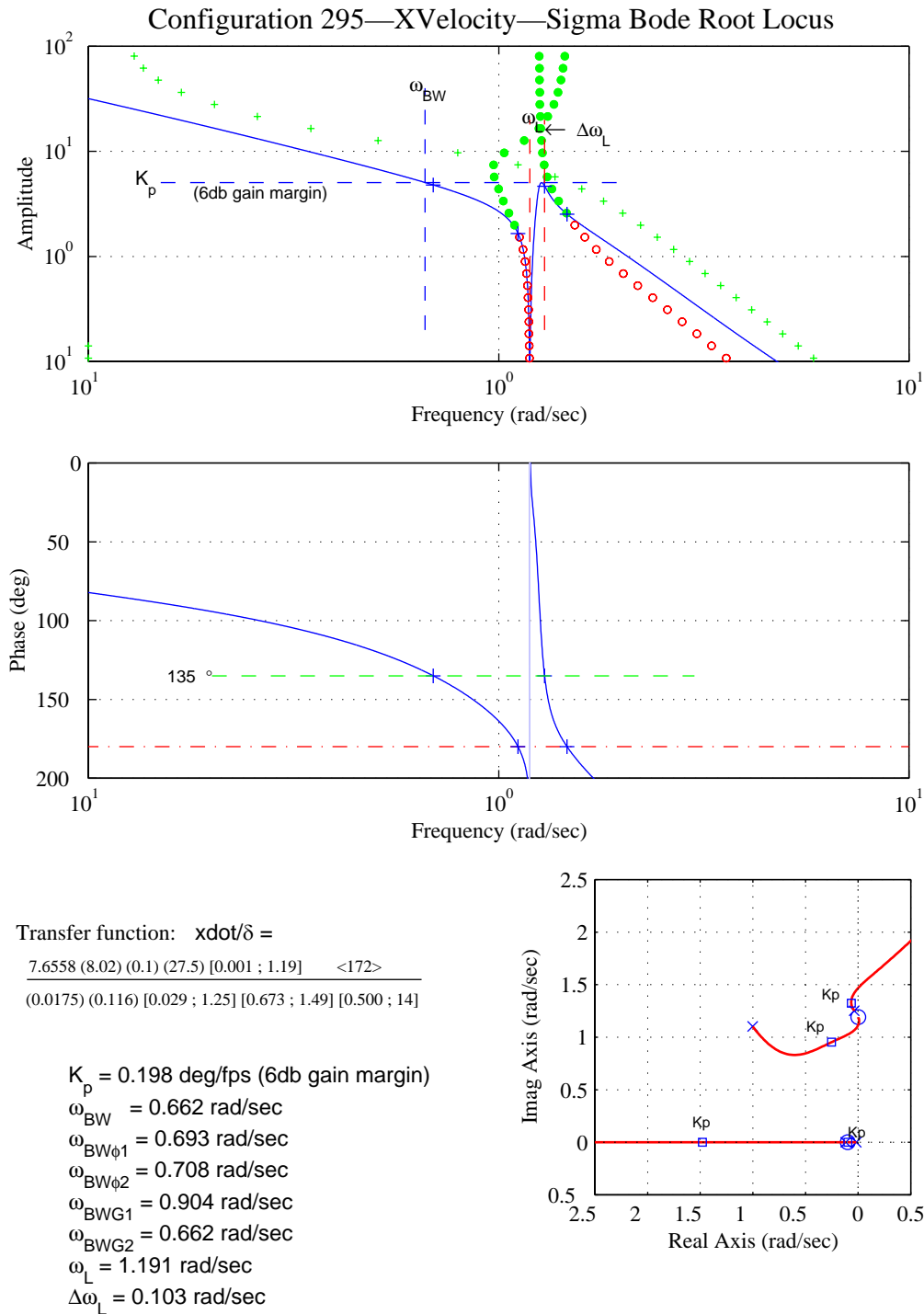

Figure D-27. Longitudinal Translational-Rate-Loop-Closure Characteristics – Configuration 295.

D.2 Lateral Velocity

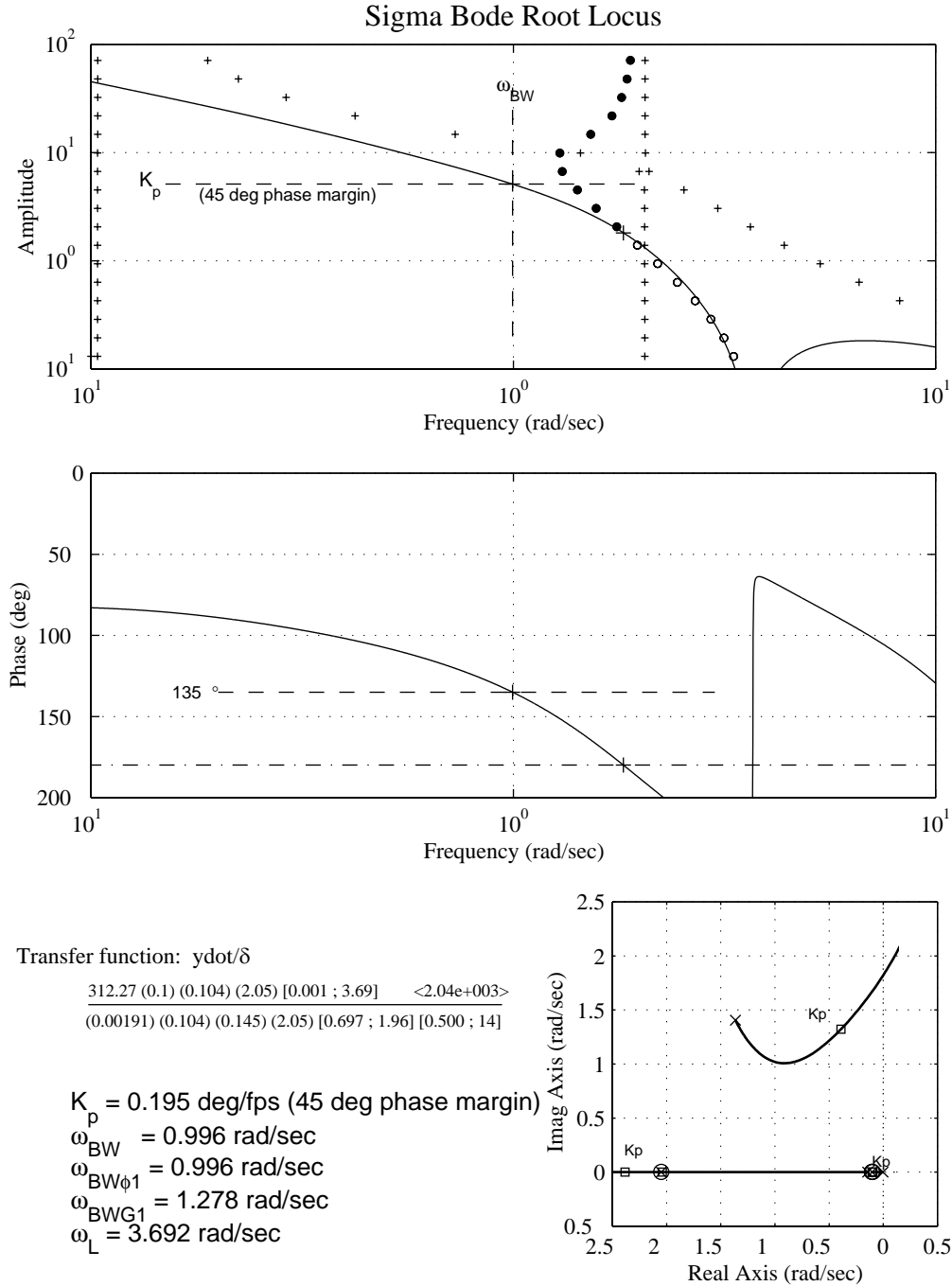

Figure D-28. Lateral Translational-Rate-Loop-Closure Characteristics – Configuration 100 – No Load.

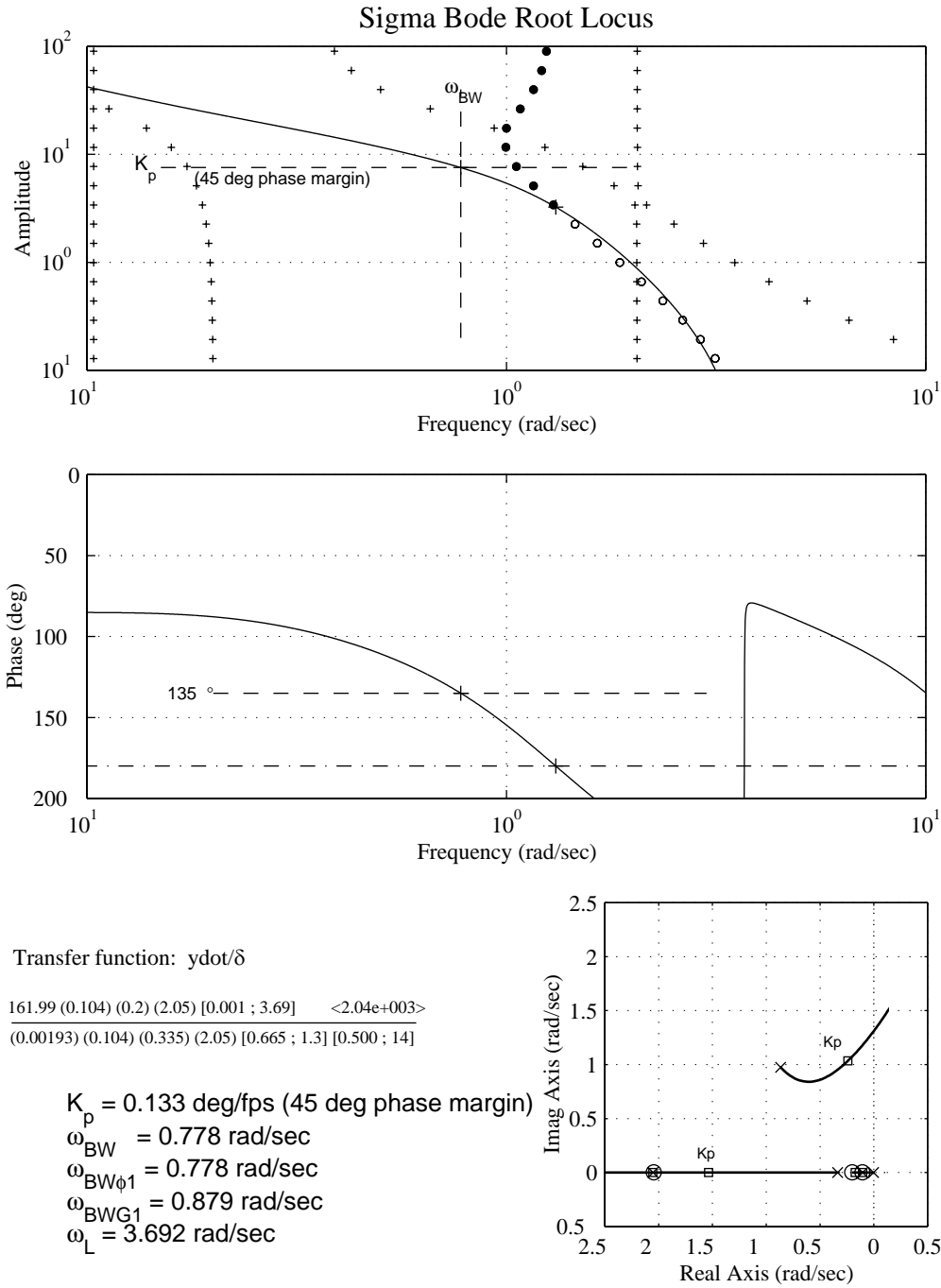

Figure D-29. Lateral Translational-Rate-Loop-Closure Characteristics – Configuration 200 – No Load.

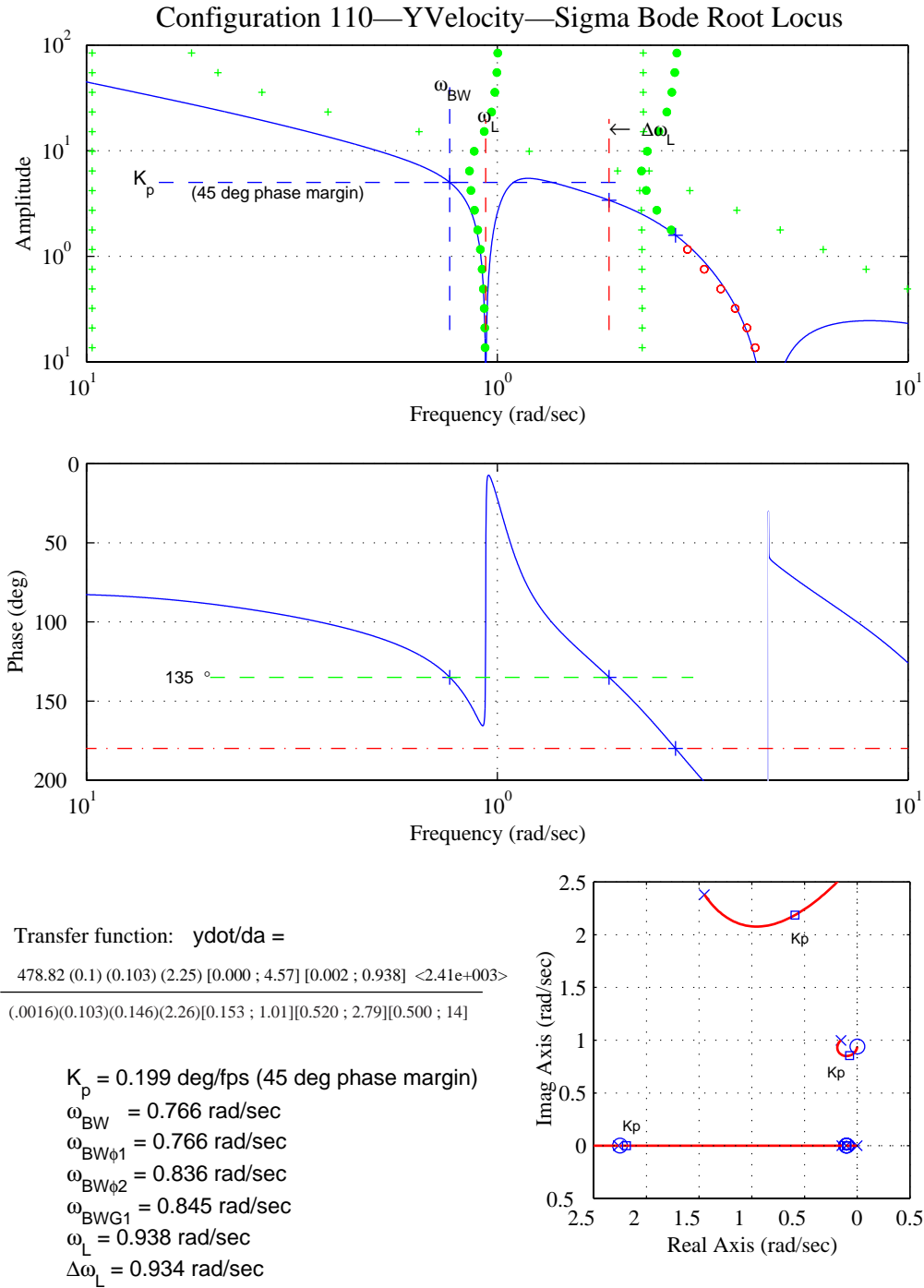

Figure D-30. Lateral Translational-Rate-Loop-Closure Characteristics – Configuration 110.

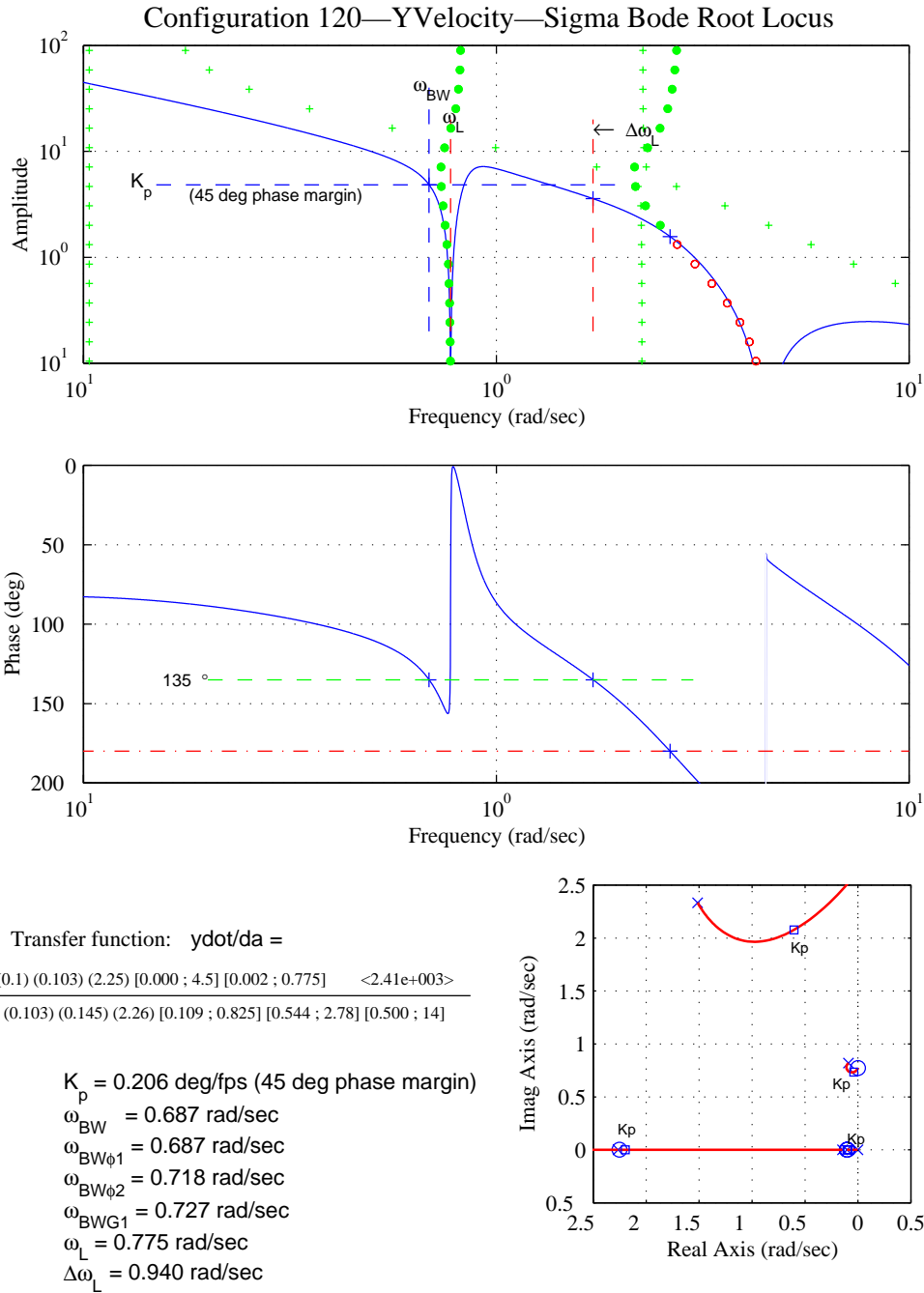
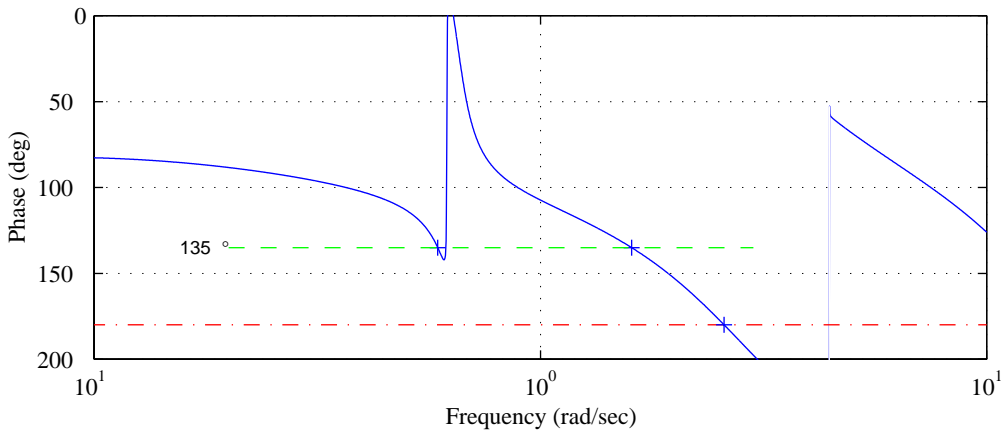
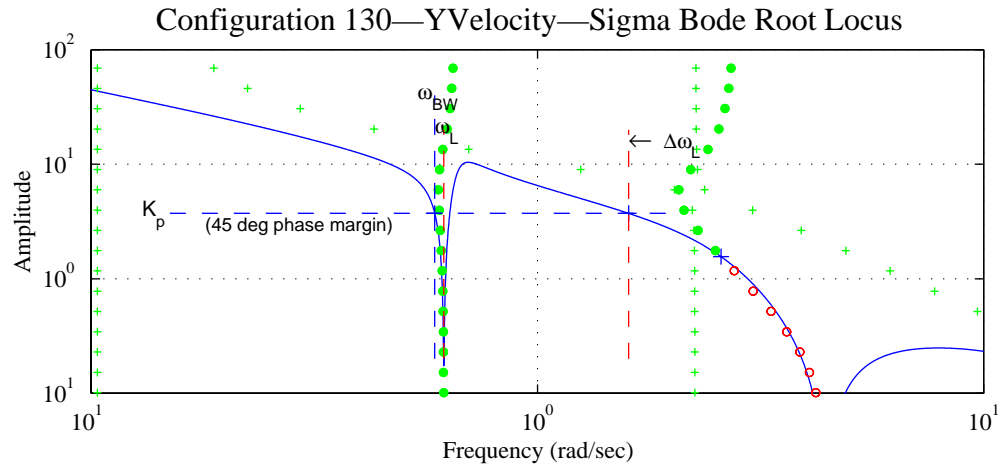

Figure D-31. Lateral Translational-Rate-Loop-Closure Characteristics – Configuration 120.



Transfer function: $ydot/da =$
 $\frac{478.82 (0.1) (0.103) (2.25) [0.000 ; 4.44] [0.002 ; 0.617] <2.41e+003>}{(0.0016) (0.103) (0.145) (2.26) [0.071 ; 0.652] [0.561 ; 2.78] [0.500 ; 14]}$

$K_p = 0.268 \text{ deg/fps (45 deg phase margin)}$
 $\omega_{BW} = 0.589 \text{ rad/sec}$
 $\omega_{BW\phi_1} = 0.589 \text{ rad/sec}$
 $\omega_{BW\phi_2} = 0.589 \text{ rad/sec}$
 $\omega_{BWG1} = 0.595 \text{ rad/sec}$
 $\omega_L = 0.617 \text{ rad/sec}$
 $\Delta\omega_L = 0.983 \text{ rad/sec}$

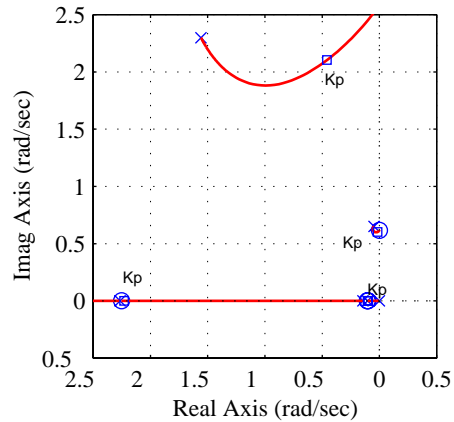

Figure D-32. Lateral Translational-Rate-Loop-Closure Characteristics – Configuration 130.

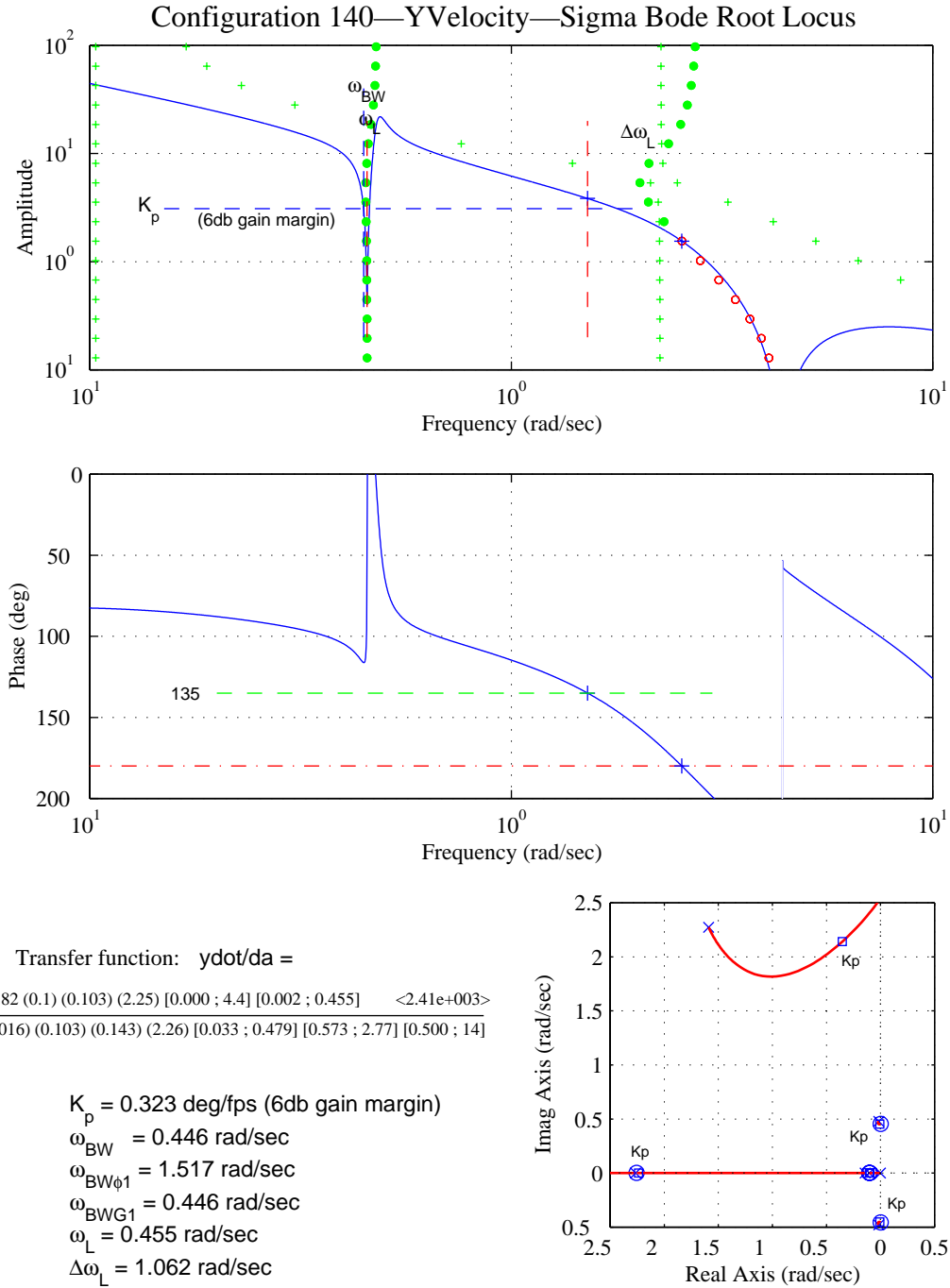
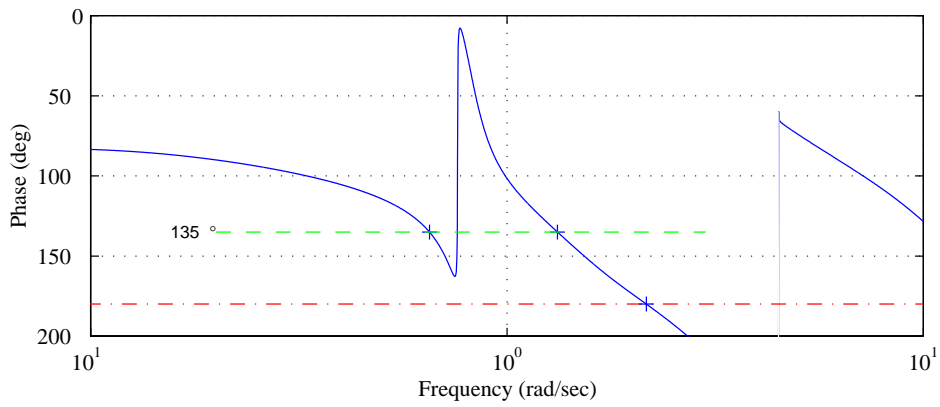
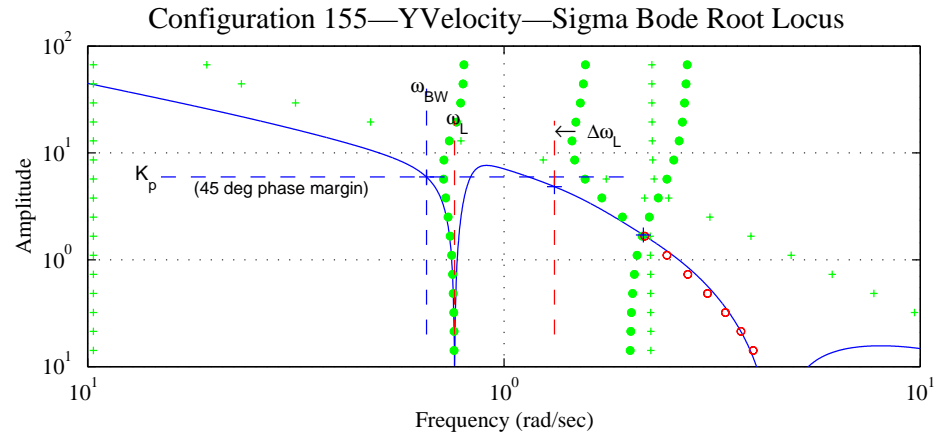

Figure D-33. Lateral Translational-Rate-Loop-Closure Characteristics – Configuration 140.



Transfer function: $y_{dot}/da =$
 $\frac{306.44 (0.1) (0.103) (2.25) [0.000 ; 4.49] [0.002 ; 0.761] [0.500 ; 2] \langle -2.41e+003 \rangle}{(0.0016) (0.103) (0.145) (2.26) [0.106 ; 0.809] [0.500 ; 1.6] [0.546 ; 2.78] [0.500 ; 14]}$

$K_p = 0.168 \text{ deg/fps (45 deg phase margin)}$
 $\omega_{BW} = 0.651 \text{ rad/sec}$
 $\omega_{BW\phi 1} = 0.651 \text{ rad/sec}$
 $\omega_{BW\phi 2} = 0.682 \text{ rad/sec}$
 $\omega_{BWG1} = 0.712 \text{ rad/sec}$
 $\omega_L = 0.761 \text{ rad/sec}$
 $\Delta\omega_L = 0.561 \text{ rad/sec}$

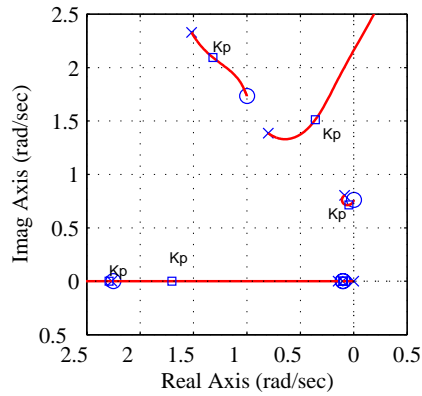
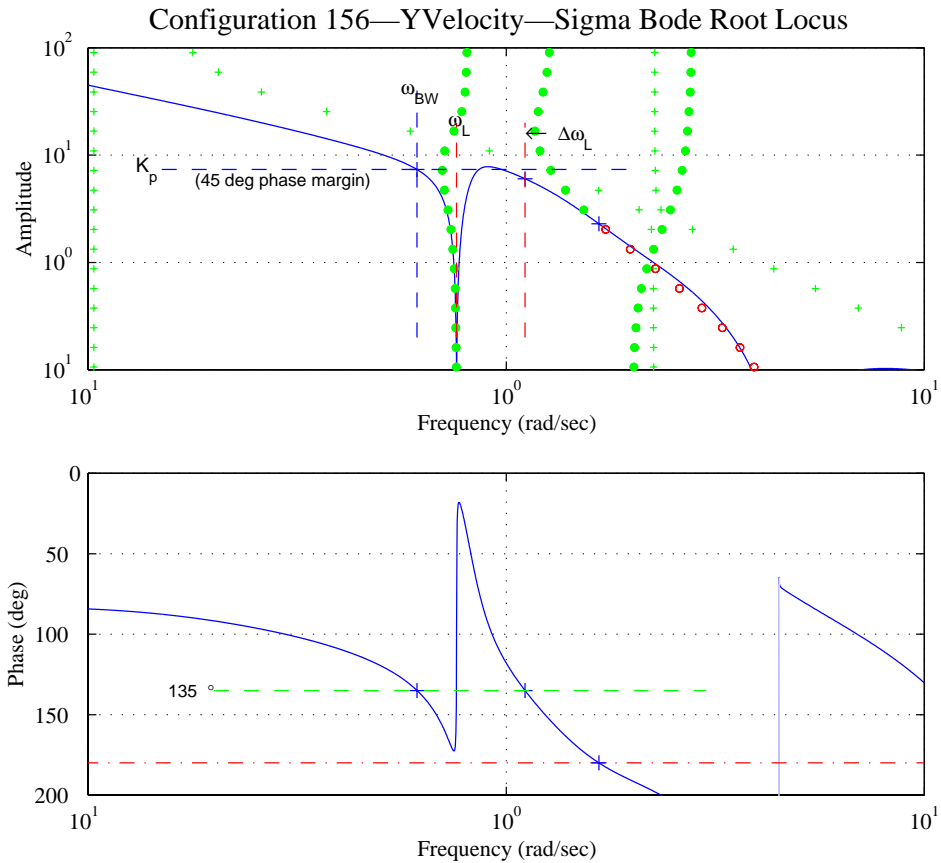

Figure D-34. Lateral Translational-Rate-Loop-Closure-Characteristics – Configuration 155.



Transfer function: $\dot{y}/da =$
 $\frac{202.3 (0.1) (0.103) (2.25) [0.000 ; 4.49] [0.002 ; 0.761] [0.500 ; 2] \langle -2.41e+003 \rangle}{(0.0016) (0.103) (0.145) (2.26) [0.106 ; 0.809] [0.500 ; 1.3] [0.546 ; 2.78] [0.500 ; 14]}$

- $K_p = 0.136 \text{ deg/fps (45 deg phase margin)}$
- $\omega_{BW} = 0.612 \text{ rad/sec}$
- $\omega_{BW\phi_1} = 0.612 \text{ rad/sec}$
- $\omega_{BW\phi_2} = 0.655 \text{ rad/sec}$
- $\omega_{BWG_1} = 0.691 \text{ rad/sec}$
- $\omega_L = 0.761 \text{ rad/sec}$
- $\Delta\omega_L = 0.348 \text{ rad/sec}$

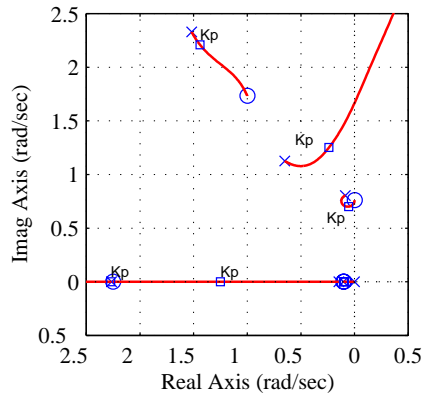
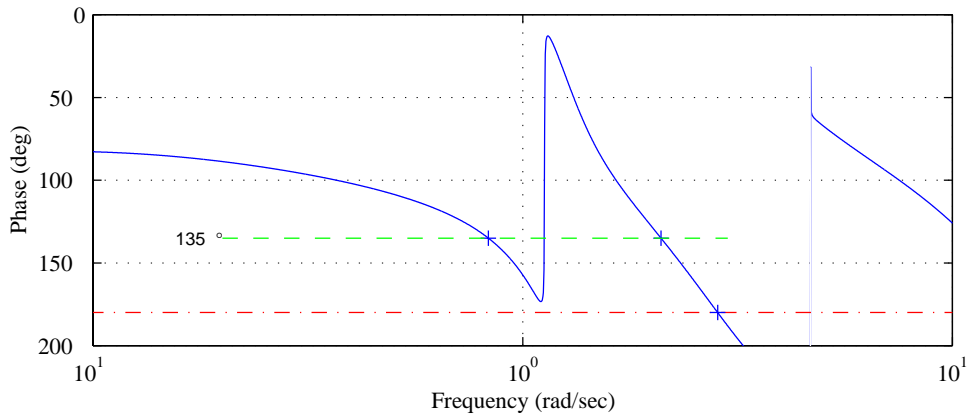
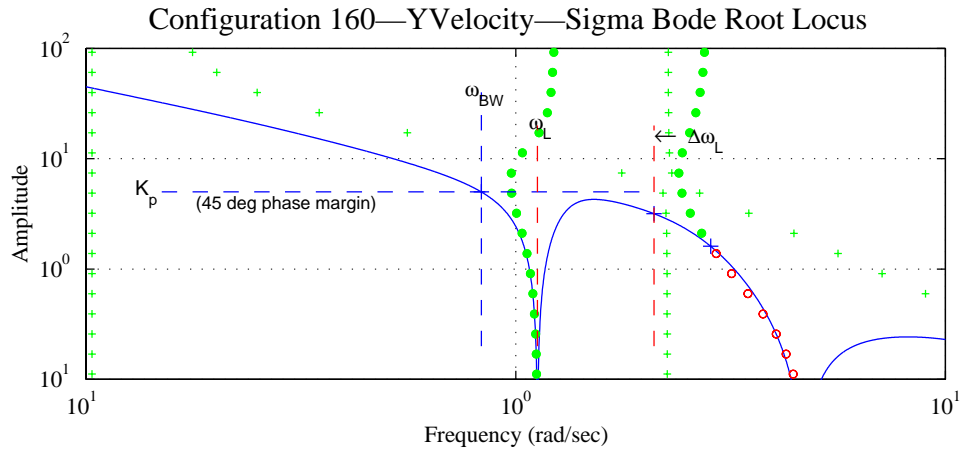

Figure D-35. Lateral Translational-Rate-Loop-Closure Characteristics – Configuration 156.



Transfer function: $y_{dot}/d_a =$

$$\frac{478.82 (0.1) (0.103) (2.25) [0.000 ; 4.68] [0.002 ; 1.12] \langle -2.41e+003 \rangle}{(0.0016) (0.103) (0.146) (2.26) [0.214 ; 1.24] [0.479 ; 2.8] [0.500 ; 14]}$$

- $K_p = 0.200 \text{ deg/fps (45 deg phase margin)}$
- $\omega_{BW} = 0.832 \text{ rad/sec}$
- $\omega_{BW\phi 1} = 0.832 \text{ rad/sec}$
- $\omega_{BW\phi 2} = 0.956 \text{ rad/sec}$
- $\omega_{BWG1} = 0.954 \text{ rad/sec}$
- $\omega_L = 1.124 \text{ rad/sec}$
- $\Delta\omega_L = 0.974 \text{ rad/sec}$

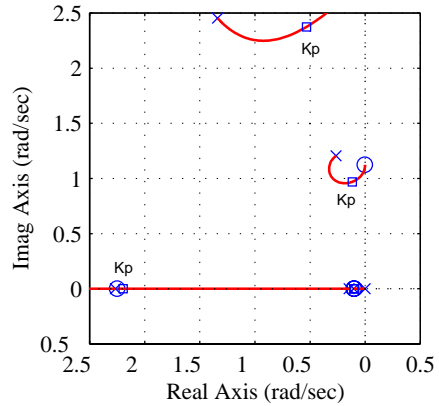
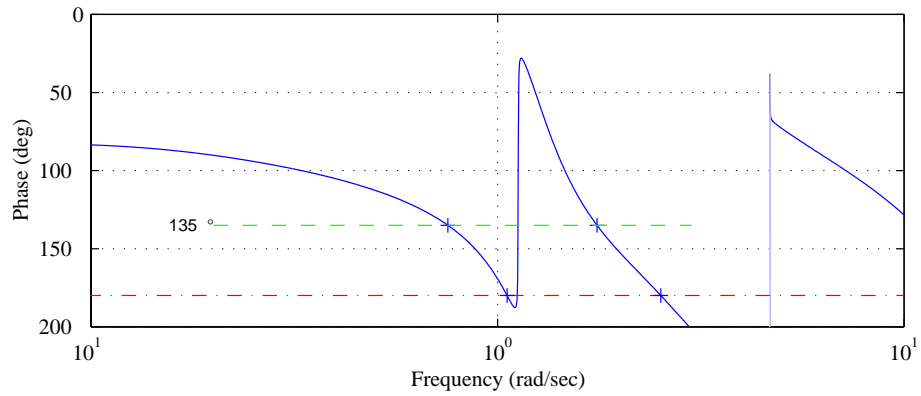
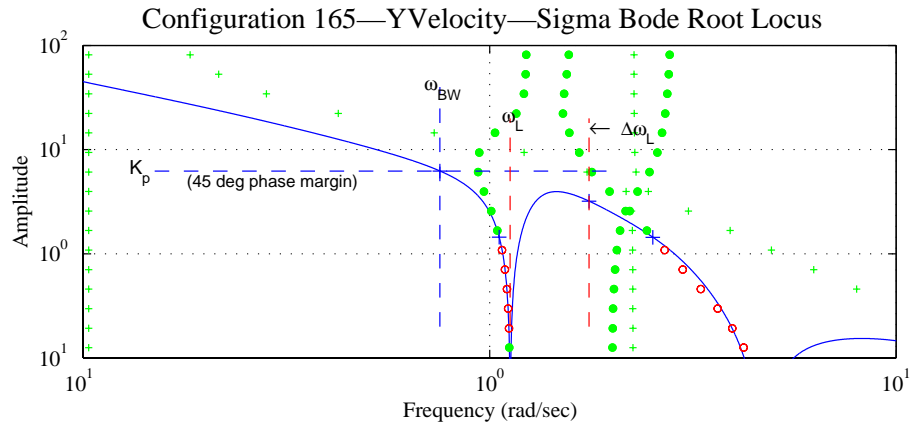

Figure D-36. Lateral Translational-Rate-Loop-Closure Characteristics – Configuration 160.



Transfer function: $y_{dot}/d_a =$
 $\frac{306.44 (0.1) (0.103) (2.25) [0.000; 4.68] [0.002; 1.12] [0.500; 2]}{(0.0016) (0.103) (0.146) (2.26) [0.214; 1.24] [0.500; 1.6] [0.479; 2.8] [0.500; 14]}$ <2.41e+003>

- $K_p = 0.160 \text{ deg/fps (45 deg phase margin)}$
- $\omega_{BW} = 0.755 \text{ rad/sec}$
- $\omega_{BW\phi_1} = 0.755 \text{ rad/sec}$
- $\omega_{BW\phi_2} = 0.961 \text{ rad/sec}$
- $\omega_{BWG1} = 0.979 \text{ rad/sec}$
- $\omega_{BWG2} = 0.979 \text{ rad/sec}$
- $\omega_L = 1.124 \text{ rad/sec}$
- $\Delta\omega_L = 0.633 \text{ rad/sec}$

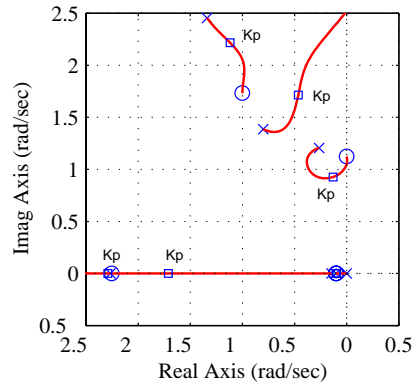
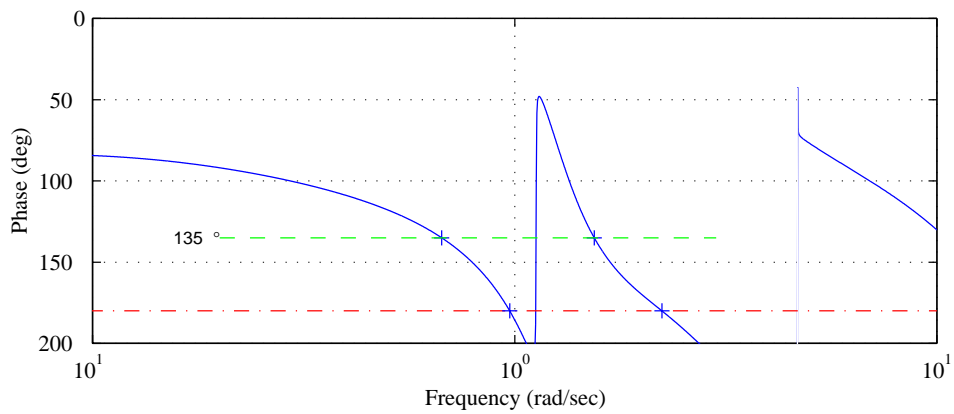
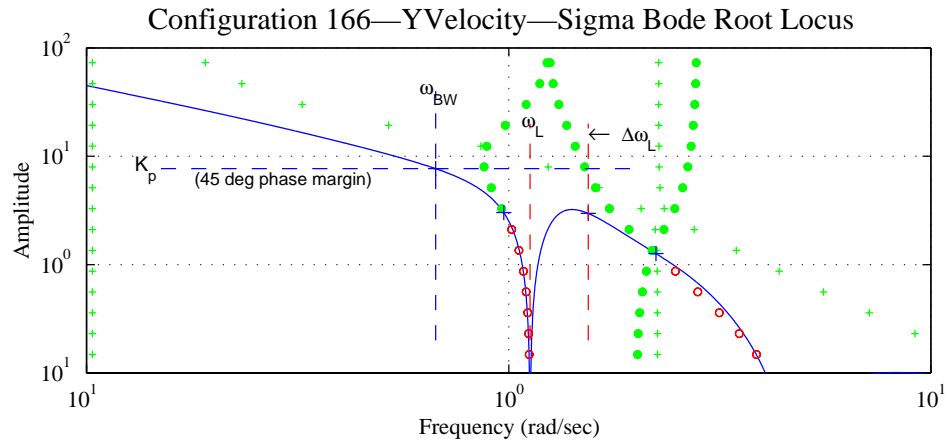

Figure D-37. Lateral Translational-Rate-Loop-Closure Characteristics – Configuration 165.



Transfer function: $\dot{y}/da =$
 $202.3 (0.1) (0.103) (2.25) [0.000 ; 4.68] [0.002 ; 1.12] [0.500 ; 2] <2.41e+003>$
 $(0.0016) (0.103) (0.146) (2.26) [0.214 ; 1.24] [0.500 ; 1.3] [0.479 ; 2.8] [0.500 ; 14]$

$K_p = 0.130$ deg/fps (45 deg phase margin)
 $\omega_{BW} = 0.671$ rad/sec
 $\omega_{BW\phi_1} = 0.671$ rad/sec
 $\omega_{BW\phi_2} = 0.976$ rad/sec
 $\omega_{BWG_1} = 0.782$ rad/sec
 $\omega_{BWG_2} = 1.000$ rad/sec
 $\omega_L = 1.124$ rad/sec
 $\Delta\omega_L = 0.419$ rad/sec

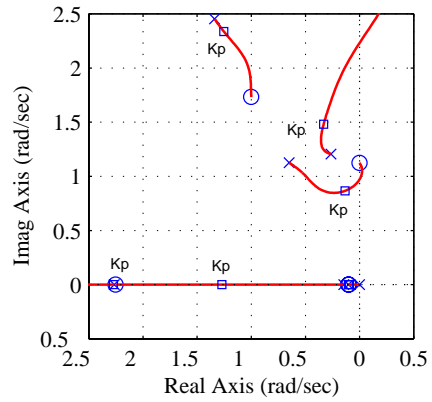
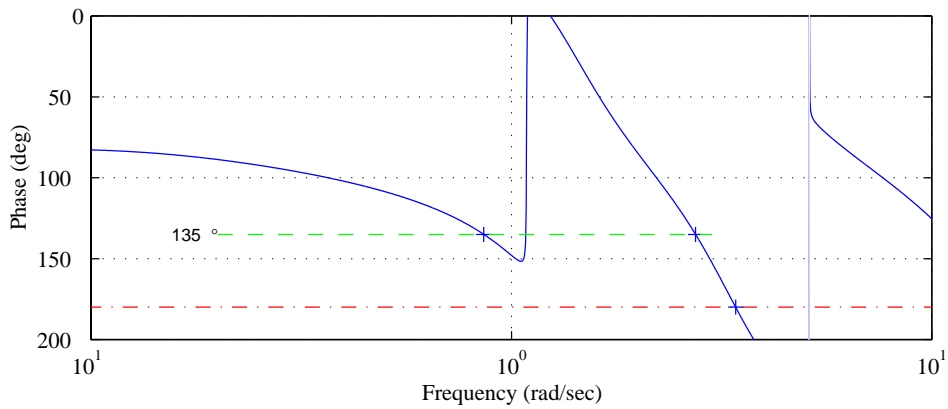
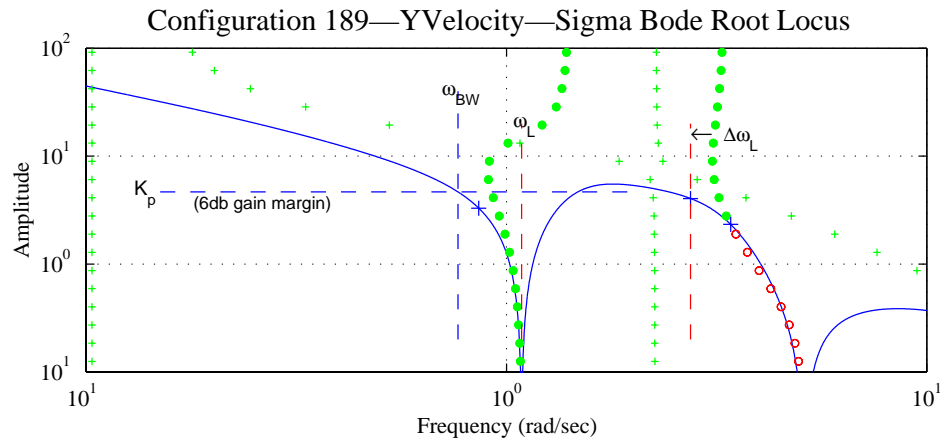

Figure D-38. Lateral Translational-Rate-Loop-Closure Characteristics – Configuration 166.



Transfer function: $\dot{y}/da =$
 $\frac{780.68 (0.1) (0.103) (2.25) [0.001 ; 5.11] [0.002 ; 1.09] <2.66e+003>}{(0.00144) (0.103) (0.147) (2.27) [0.355 ; 1.41] [0.336 ; 3.3] [0.500 ; 14]}$

$K_p = 0.215 \text{ deg/fps (6db gain margin)}$
 $\omega_{BW} = 0.767 \text{ rad/sec}$
 $\omega_{BW\phi1} = 0.860 \text{ rad/sec}$
 $\omega_{BW\phi2} = 0.808 \text{ rad/sec}$
 $\omega_{BWG1} = 0.767 \text{ rad/sec}$
 $\omega_L = 1.087 \text{ rad/sec}$
 $\Delta\omega_L = 1.655 \text{ rad/sec}$

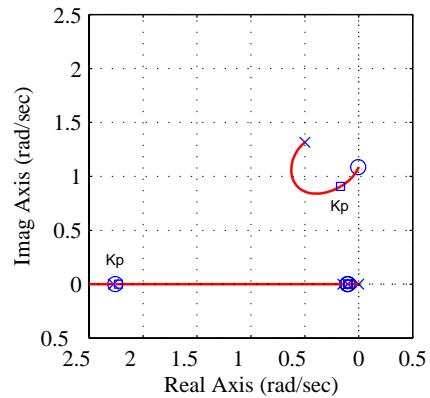
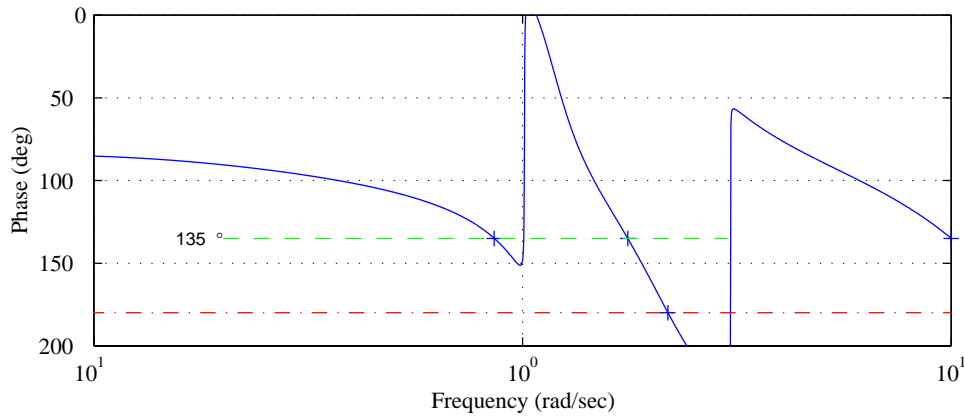
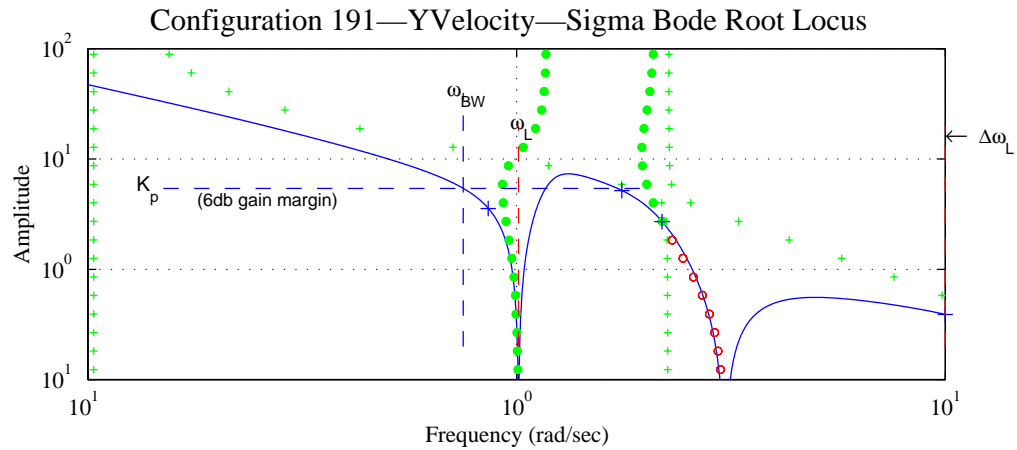

Figure D-39. Lateral Translational-Rate-Loop-Closure Characteristics – Configuration 189.



Transfer function: $\dot{y}/d_a =$
 $\frac{703.26 (0.1) (0.103) (2.25) [0.000 ; 3.06] [0.002 ; 1.01] \langle 2.41e+003 \rangle}{(0.00176) (0.103) (0.13) (2.26) [0.162 ; 1.18] [0.323 ; 2.12] [0.500 ; 14]}$

$K_p = 0.184 \text{ deg/fps (6db gain margin)}$
 $\omega_{BW} = 0.751 \text{ rad/sec}$
 $\omega_{BW\phi_1} = 0.859 \text{ rad/sec}$
 $\omega_{BW\phi_2} = 0.765 \text{ rad/sec}$
 $\omega_{BWG_1} = 0.751 \text{ rad/sec}$
 $\omega_L = 1.011 \text{ rad/sec}$
 $\Delta\omega_L = 8.989 \text{ rad/sec}$

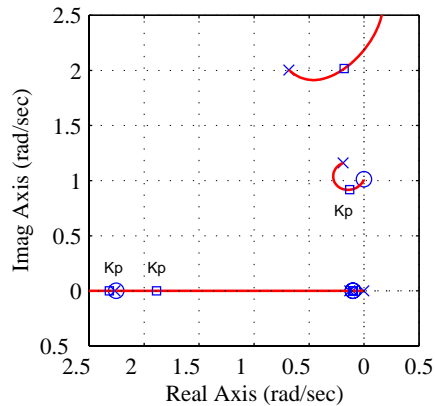
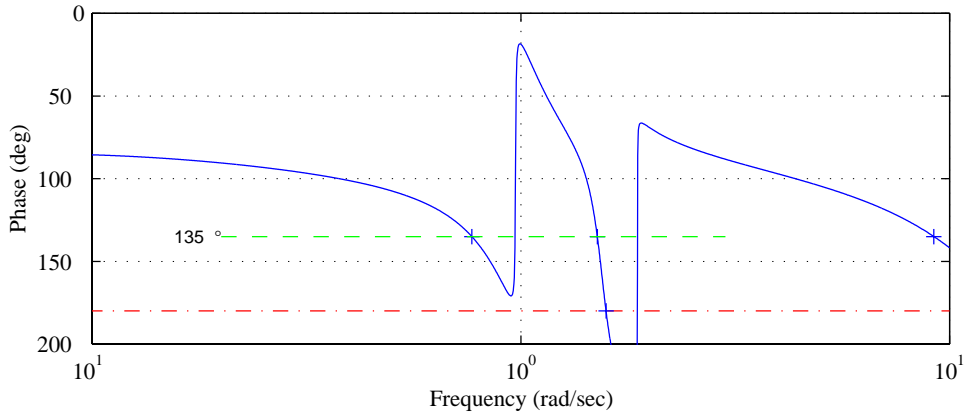
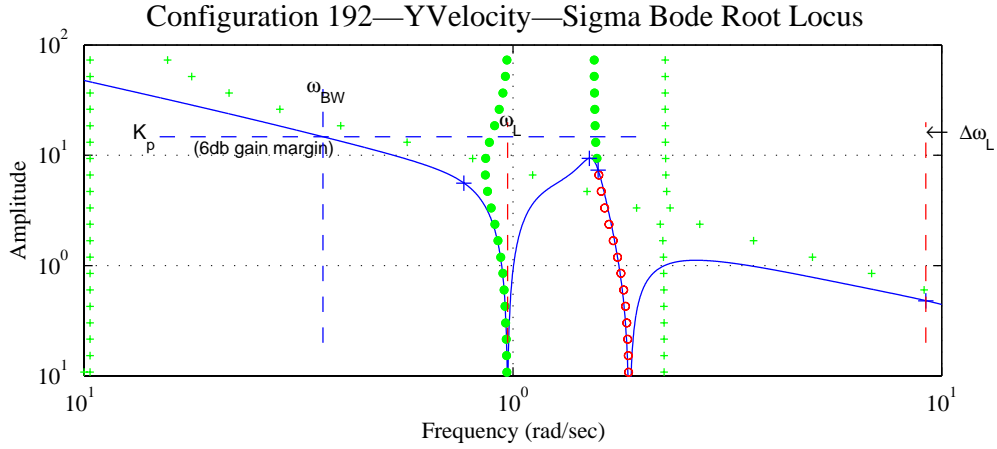

Figure D-40. Lateral Translational-Rate-Loop-Closure Characteristics – Configuration 191.



Transfer function: $y_{dot}/d_a =$
 $\frac{763.11 (0.1) (0.103) (2.25) [0.001 ; 1.87] [0.003 ; 0.972] \langle -2.41e+003 \rangle}{(0.00179) (0.103) (0.127) (2.27) [0.061 ; 1.55] [0.216 ; 0.989] [0.500 ; 14]}$

$K_p = 0.068 \text{ deg/fps (6db gain margin)}$
 $\omega_{BW} = 0.361 \text{ rad/sec}$
 $\omega_{BW\phi_1} = 0.769 \text{ rad/sec}$
 $\omega_{BW\phi_2} = 0.557 \text{ rad/sec}$
 $\omega_{BWG1} = 0.361 \text{ rad/sec}$
 $\omega_L = 0.972 \text{ rad/sec}$
 $\Delta\omega_L = 8.219 \text{ rad/sec}$

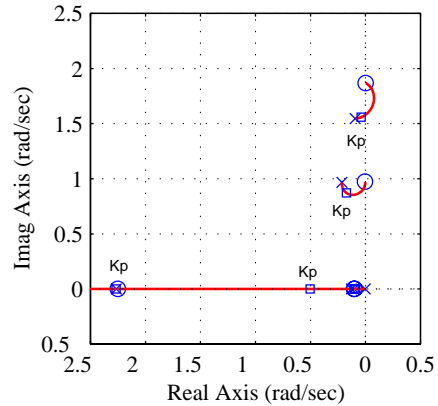
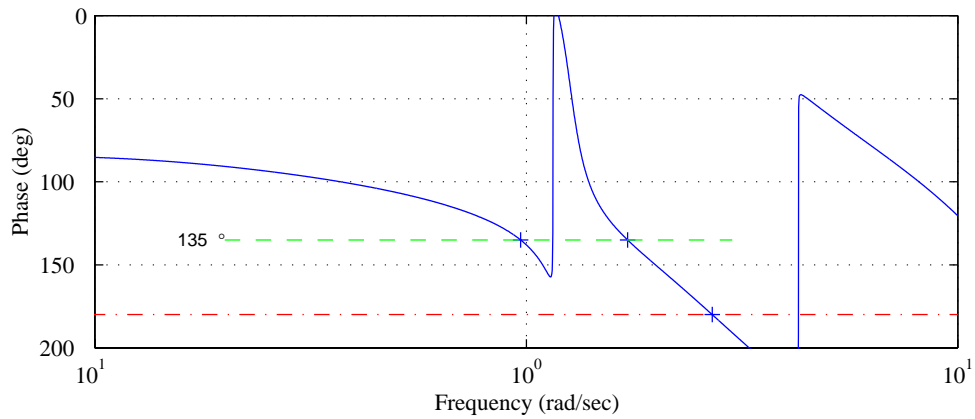
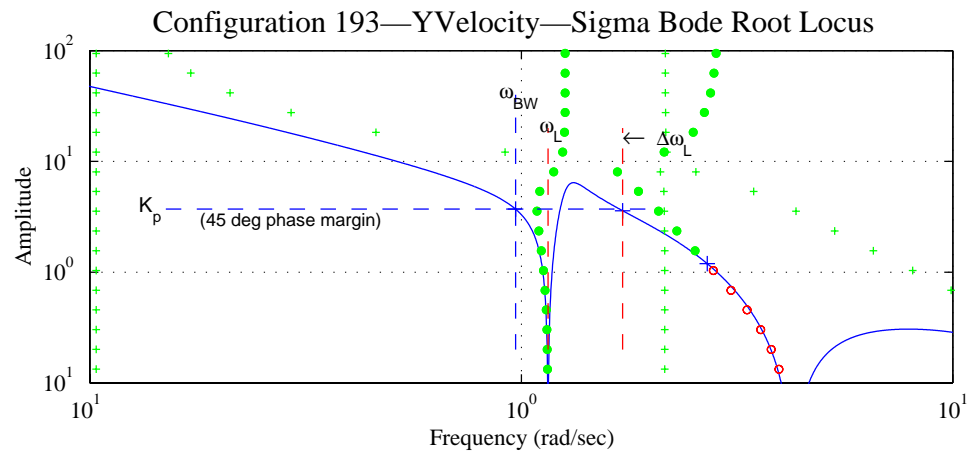

Figure D-41. Lateral Translational-Rate-Loop-Closure Characteristics – Configuration 192.



Transfer function: $\dot{y}/d_a =$
 $\frac{593.31 (0.1) (0.103) (2.15) [0.000 ; 4.27] [0.001 ; 1.15] \langle 2.13e+003 \rangle}{(0.002) (0.103) (0.13) (2.16) [0.073 ; 1.26] [0.699 ; 2.89] [0.500 ; 14]}$

$K_p = 0.269 \text{ deg/fps (45 deg phase margin)}$
 $\omega_{BW} = 0.970 \text{ rad/sec}$
 $\omega_{BW\phi1} = 0.970 \text{ rad/sec}$
 $\omega_{BW\phi2} = 0.979 \text{ rad/sec}$
 $\omega_{BWG1} = 1.059 \text{ rad/sec}$
 $\omega_L = 1.153 \text{ rad/sec}$
 $\Delta\omega_L = 0.563 \text{ rad/sec}$

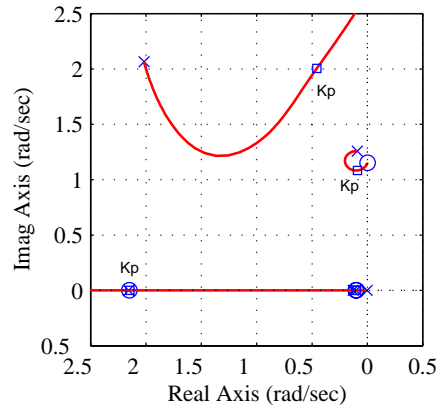
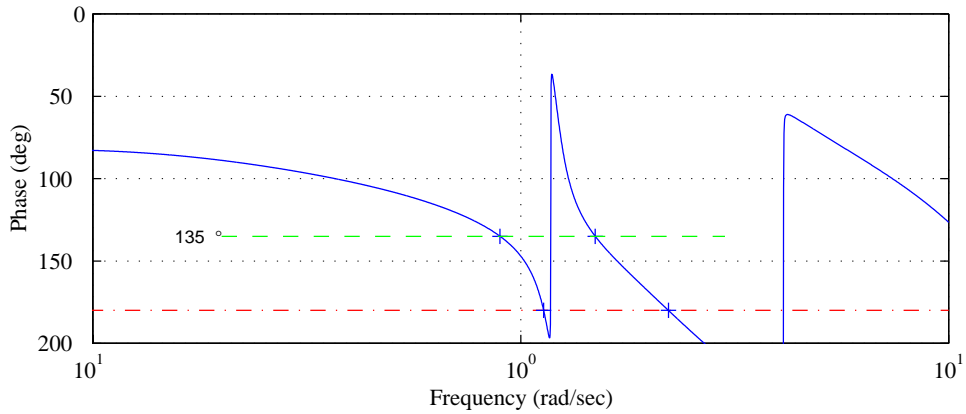
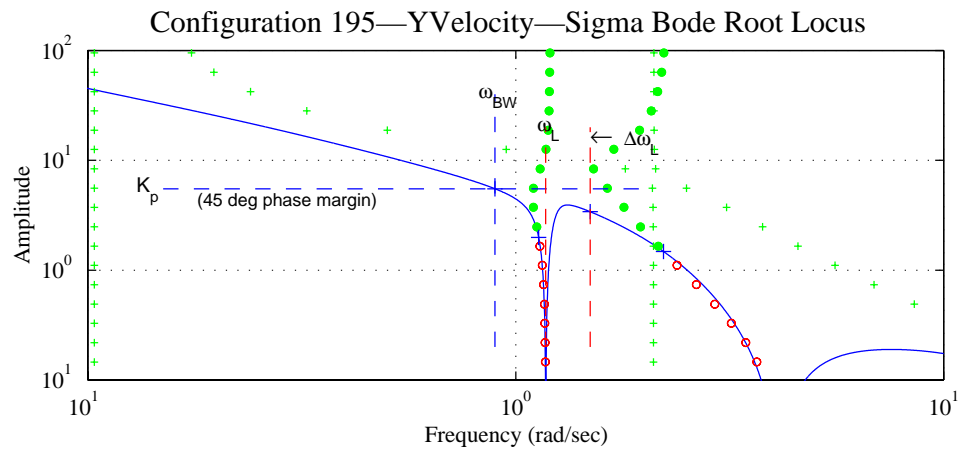

Figure D-42. Lateral Translational-Rate-Loop-Closure Characteristics – Configuration 193.



Transfer function: $\dot{y}/d_a =$
 $\frac{353.9 (0.1) (0.104) (2.1) [0.001 ; 1.18] [0.001 ; 4.11] \langle 2.06e+003 \rangle}{(0.00188) (0.104) (0.145) (2.1) [0.066 ; 1.2] [0.674 ; 2.27] [0.500 ; 14]}$

$K_p = 0.181 \text{ deg/fps (45 deg phase margin)}$
 $\omega_{BW} = 0.895 \text{ rad/sec}$
 $\omega_{BW\phi_1} = 0.895 \text{ rad/sec}$
 $\omega_{BW\phi_2} = 1.075 \text{ rad/sec}$
 $\omega_{BWG_1} = 1.039 \text{ rad/sec}$
 $\omega_{BWG_2} = 1.097 \text{ rad/sec}$
 $\omega_L = 1.175 \text{ rad/sec}$
 $\Delta\omega_L = 0.318 \text{ rad/sec}$

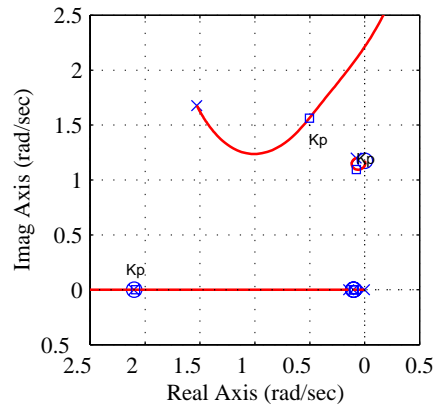

Figure D-43. Lateral Translational-Rate-Loop-Closure Characteristics – Configuration 195.

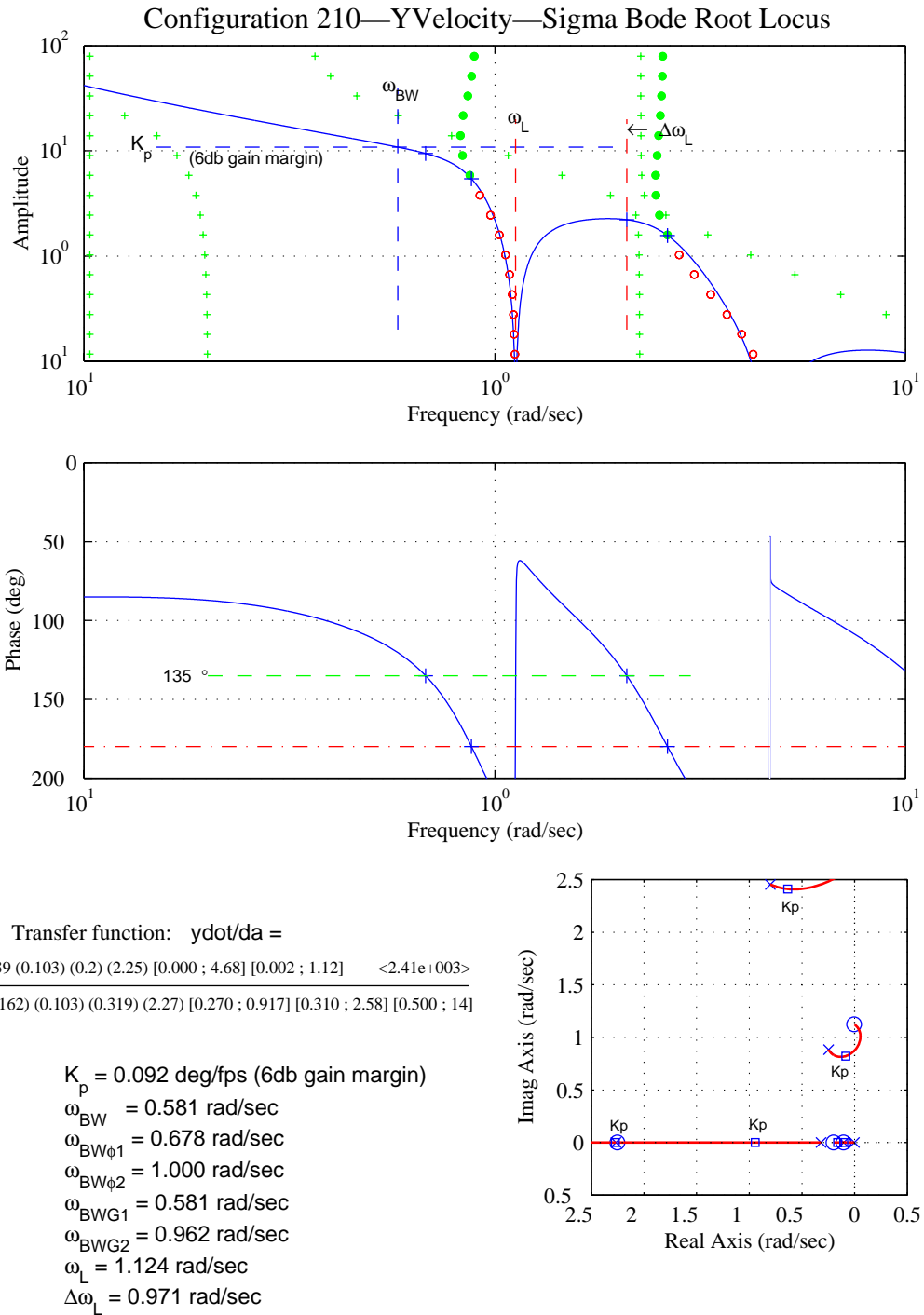
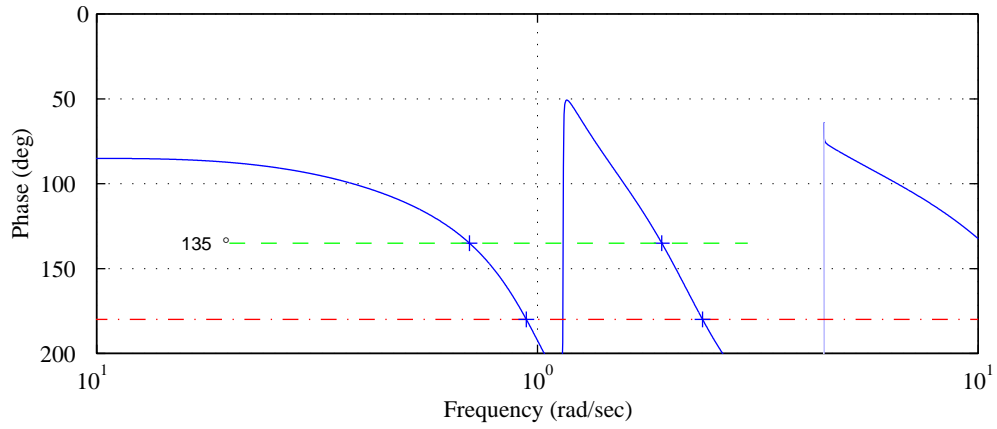
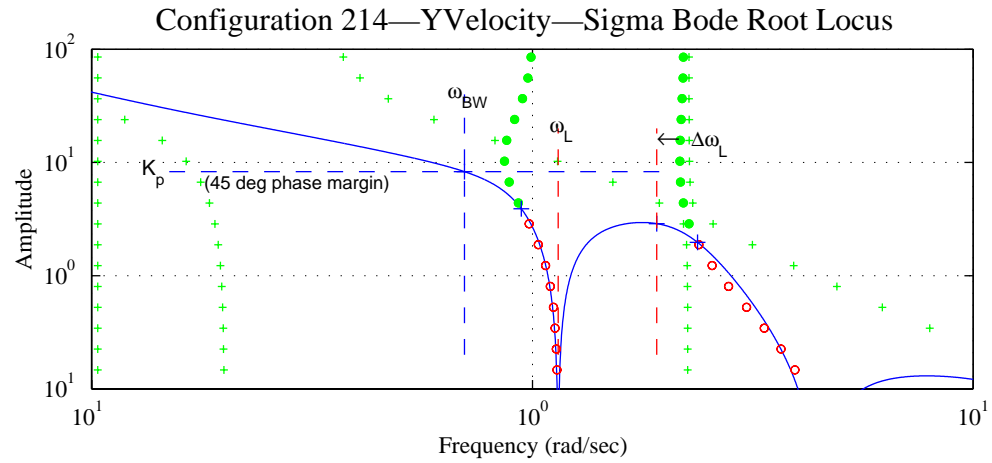

Figure D-44. Lateral Translational-Rate-Loop-Closure Characteristics – Configuration 210.



Transfer function: $y_{dot}/d_a =$
 $\frac{248.39 (0.103) (0.2) (2.25) [0.000 ; 4.47] [0.001 ; 1.14] \langle 2.29e+003 \rangle}{(0.00171) (0.103) (0.325) (2.27) [0.310 ; 1.03] [0.327 ; 2.22] [0.500 ; 14]}$

$K_p = 0.120 \text{ deg/fps (45 deg phase margin)}$
 $\omega_{BW} = 0.701 \text{ rad/sec}$
 $\omega_{BW\phi1} = 0.701 \text{ rad/sec}$
 $\omega_{BW\phi2} = 0.991 \text{ rad/sec}$
 $\omega_{BWG1} = 0.734 \text{ rad/sec}$
 $\omega_{BWG2} = 0.942 \text{ rad/sec}$
 $\omega_L = 1.144 \text{ rad/sec}$
 $\Delta\omega_L = 0.771 \text{ rad/sec}$

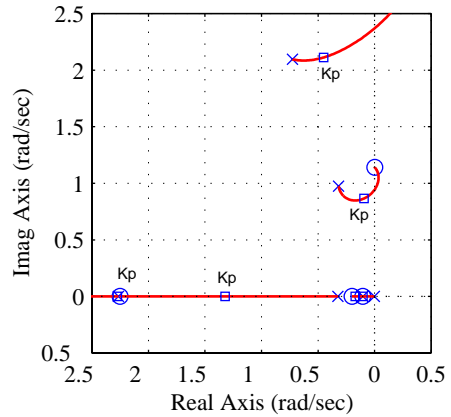
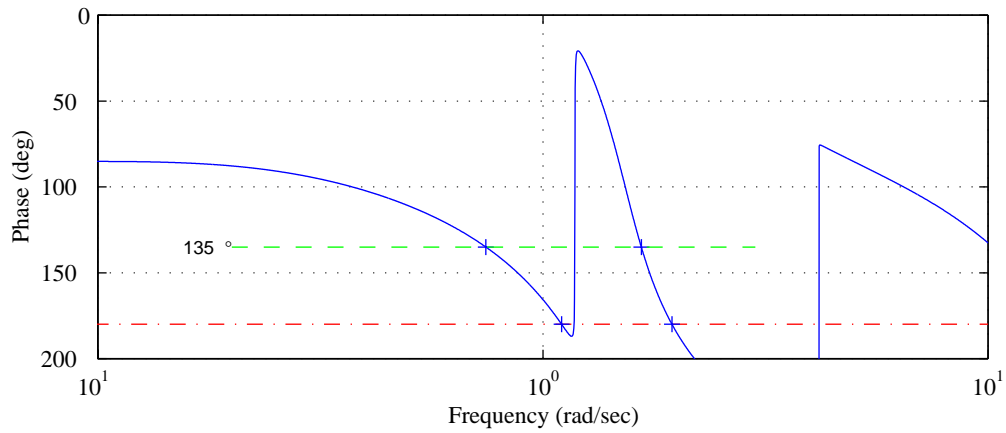
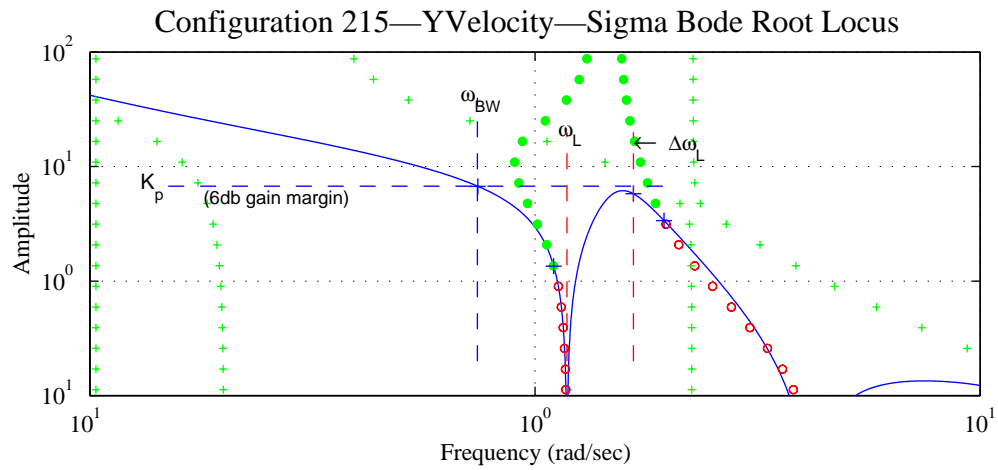

Figure D-45. Lateral Translational-Rate-Loop-Closure Characteristics – Configuration 214.



Transfer function: $\dot{y}/da =$
 $\frac{248.39 (0.103) (0.2) (2.25) [0.000 ; 4.17] [0.001 ; 1.18] \langle 2.12e+003 \rangle}{(0.00185) (0.103) (0.335) (2.26) [0.171 ; 1.53] [0.553 ; 1.4] [0.500 ; 14]}$

- $K_p = 0.148 \text{ deg/fps (6db gain margin)}$
- $\omega_{BW} = 0.743 \text{ rad/sec}$
- $\omega_{BW\phi1} = 0.744 \text{ rad/sec}$
- $\omega_{BW\phi2} = 0.807 \text{ rad/sec}$
- $\omega_{BWG1} = 1.017 \text{ rad/sec}$
- $\omega_{BWG2} = 0.743 \text{ rad/sec}$
- $\omega_L = 1.180 \text{ rad/sec}$
- $\Delta\omega_L = 0.484 \text{ rad/sec}$

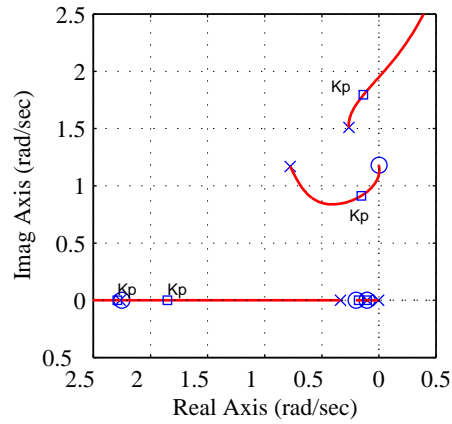

Figure D-46. Lateral Translational-Rate-Loop-Closure Characteristics – Configuration 215.

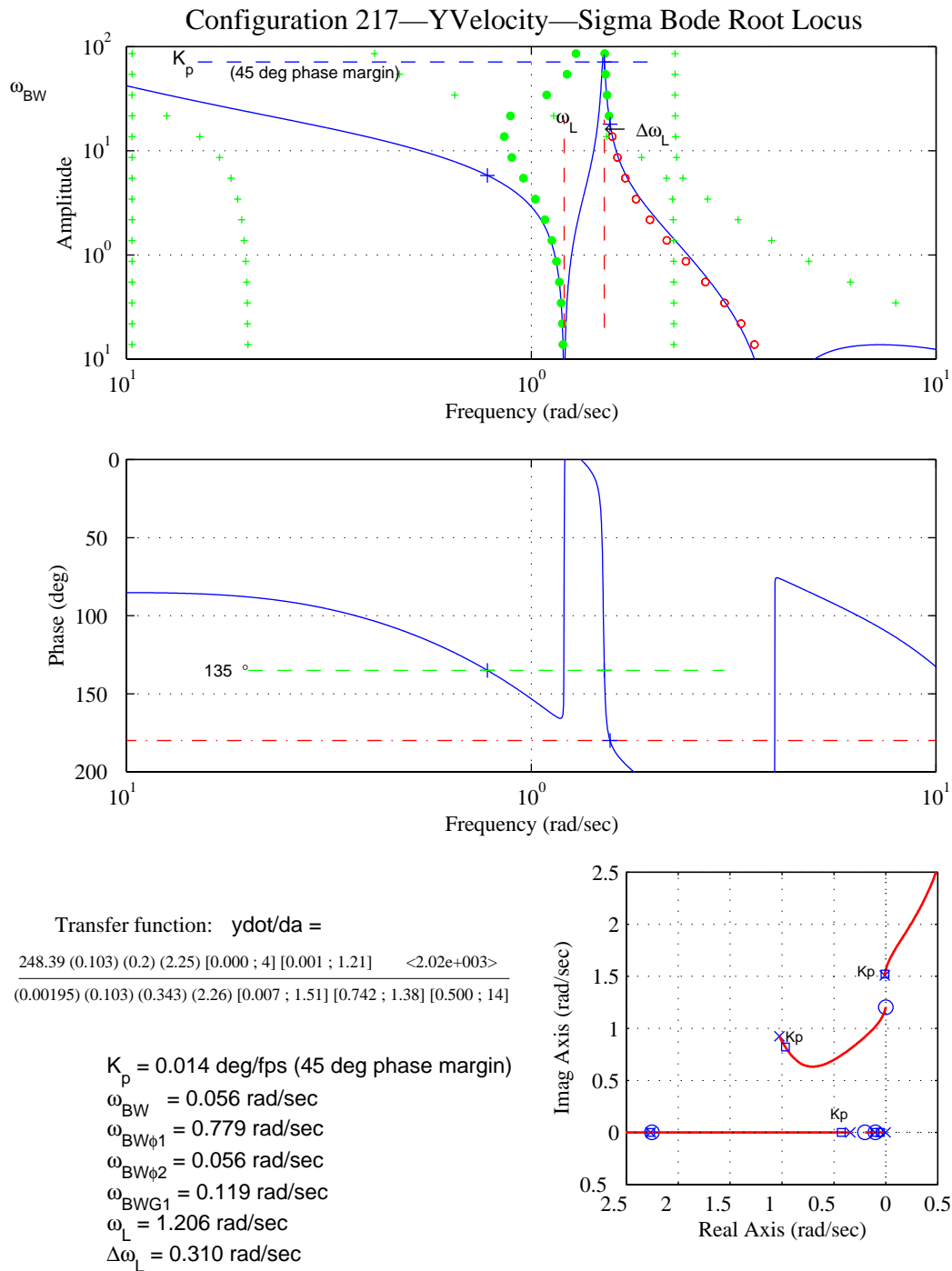
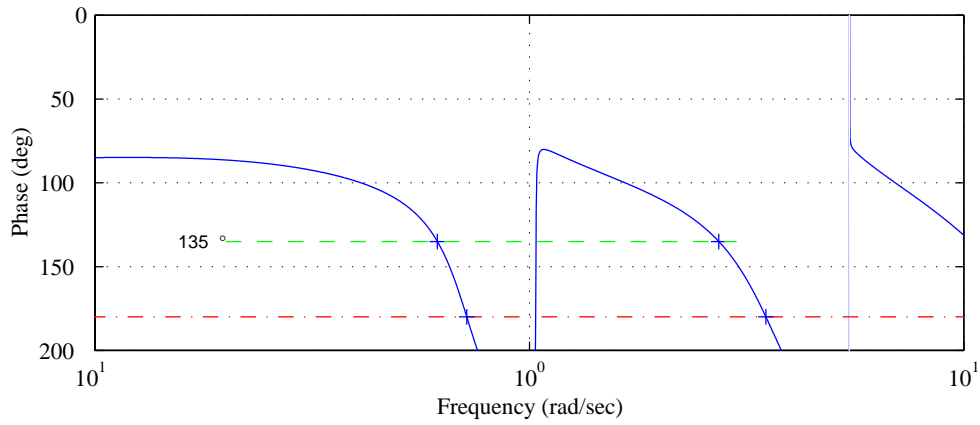
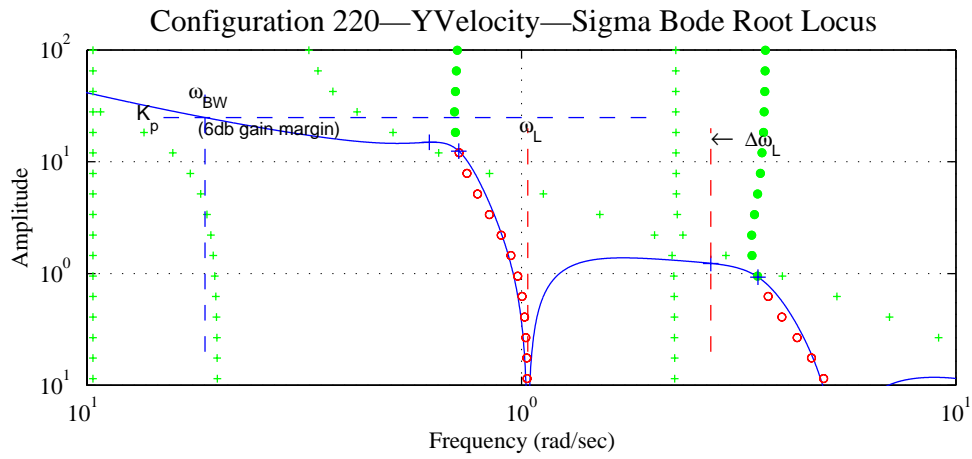

Figure D-47. Lateral Translational-Rate-Loop-Closure Characteristics – Configuration 217.



Transfer function: $y_{dot}/d_a =$
 $\frac{248.39 (0.103) (0.2) (2.25) [0.000 ; 5.46] [0.002 ; 1.03] \langle 2.8e+003 \rangle}{(0.00139) (0.103) (0.299) (2.27) [0.165 ; 0.721] [0.257 ; 3.65] [0.500 ; 14]}$

$K_p = 0.040$ deg/fps (6db gain margin)
 $\omega_{BW} = 0.187$ rad/sec
 $\omega_{BW\phi1} = 0.614$ rad/sec
 $\omega_{BW\phi2} = 0.944$ rad/sec
 $\omega_{BWG1} = 0.187$ rad/sec
 $\omega_{BWG2} = 0.915$ rad/sec
 $\omega_L = 1.034$ rad/sec
 $\Delta\omega_L = 1.694$ rad/sec

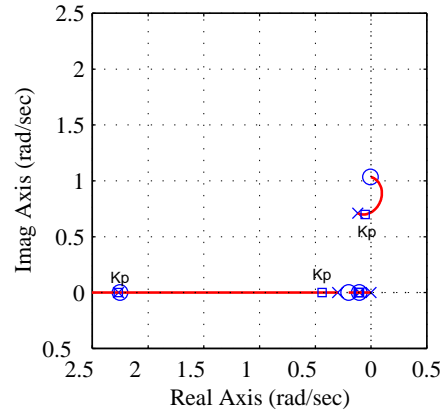
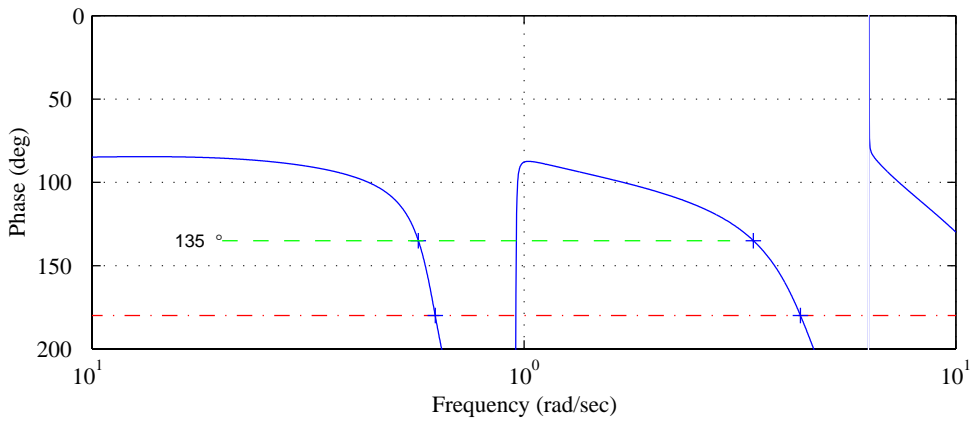
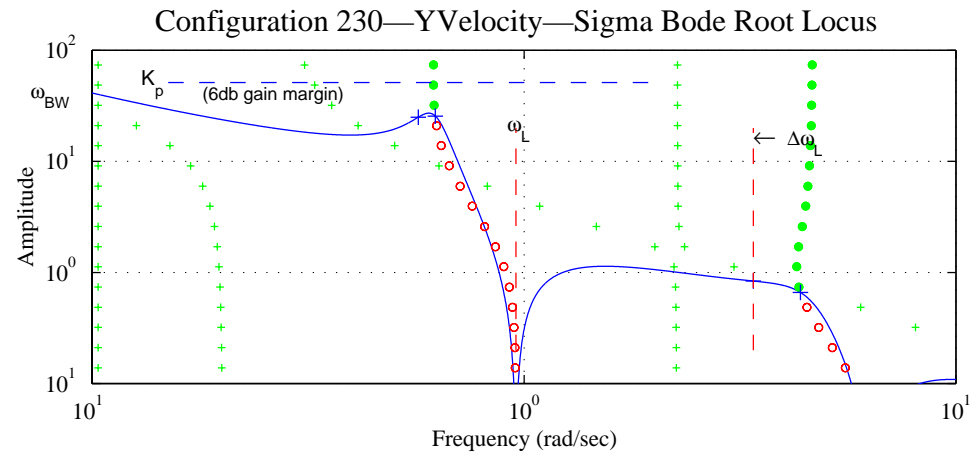

Figure D-48. Lateral Translational-Rate-Loop-Closure Characteristics – Configuration 220.



Transfer function: $\dot{y}/d_a =$
 $\frac{248.39 (0.103) (0.2) (2.25) [0.000 ; 6.29] [0.003 ; 0.958] <3.19e+003>}{(0.00121) (0.103) (0.284) (2.27) [0.095 ; 0.622] [0.216 ; 4.65] [0.500 ; 14]}$

- $K_p = 0.019 \text{ deg/fps (6db gain margin)}$
- $\omega_{BW} = 0.079 \text{ rad/sec}$
- $\omega_{BW\phi1} = 0.569 \text{ rad/sec}$
- $\omega_{BW\phi2} = 0.886 \text{ rad/sec}$
- $\omega_{BWG1} = 0.079 \text{ rad/sec}$
- $\omega_{BWG2} = 0.858 \text{ rad/sec}$
- $\omega_L = 0.958 \text{ rad/sec}$
- $\Delta\omega_L = 2.439 \text{ rad/sec}$

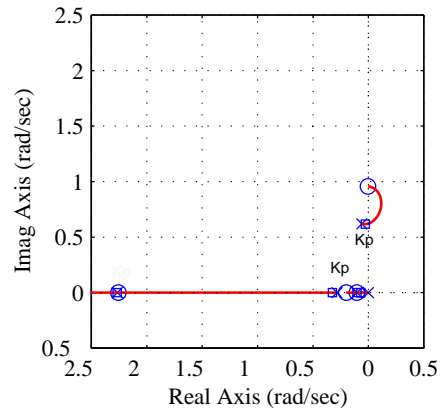
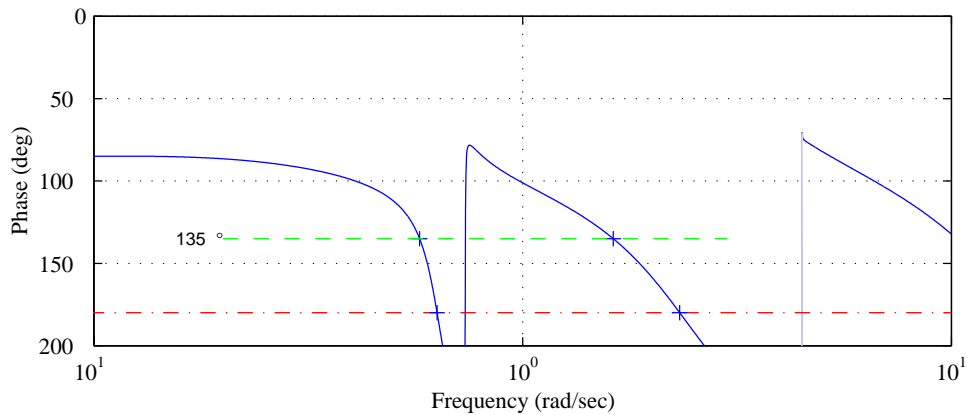
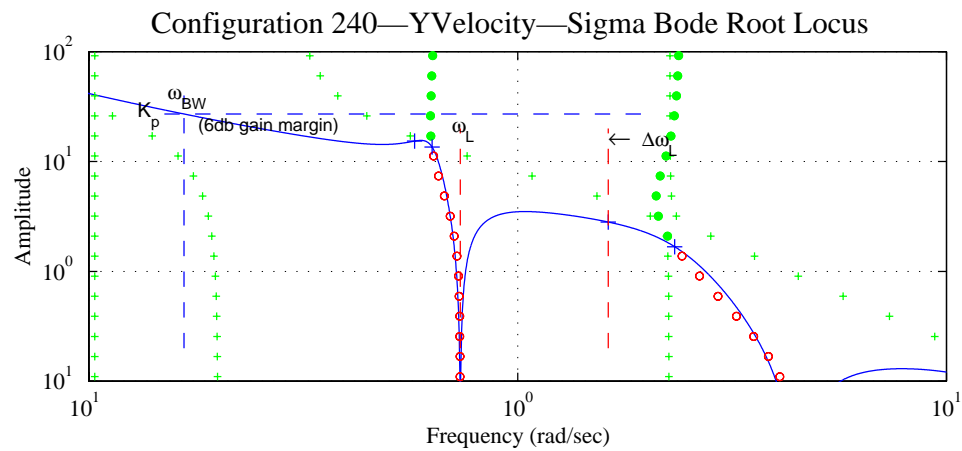

Figure D-49. Lateral Translational-Rate-Loop-Closure Characteristics – Configuration 230.



Transfer function: $y_{dot}/d_a =$
 $\frac{248.39 (0.103) (0.2) (2.25) [0.000 ; 4.48] [0.002 ; 0.735] \langle -2.41e+003 \rangle}{(0.00162) (0.103) (0.299) (2.27) [0.087 ; 0.639] [0.418 ; 2.4] [0.500 ; 14]}$

$K_p = 0.037 \text{ deg/fps (6db gain margin)}$
 $\omega_{BW} = 0.167 \text{ rad/sec}$
 $\omega_{BW\phi1} = 0.575 \text{ rad/sec}$
 $\omega_{BW\phi2} = 0.700 \text{ rad/sec}$
 $\omega_{BWG1} = 0.167 \text{ rad/sec}$
 $\omega_{BWG2} = 0.695 \text{ rad/sec}$
 $\omega_L = 0.735 \text{ rad/sec}$
 $\Delta\omega_L = 0.891 \text{ rad/sec}$

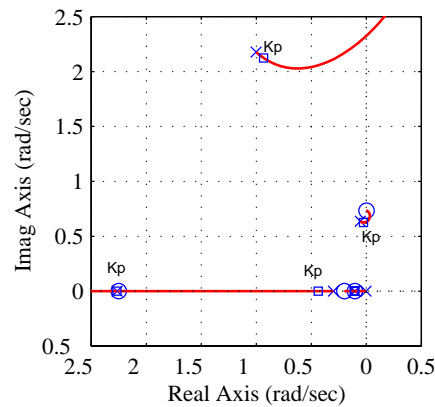
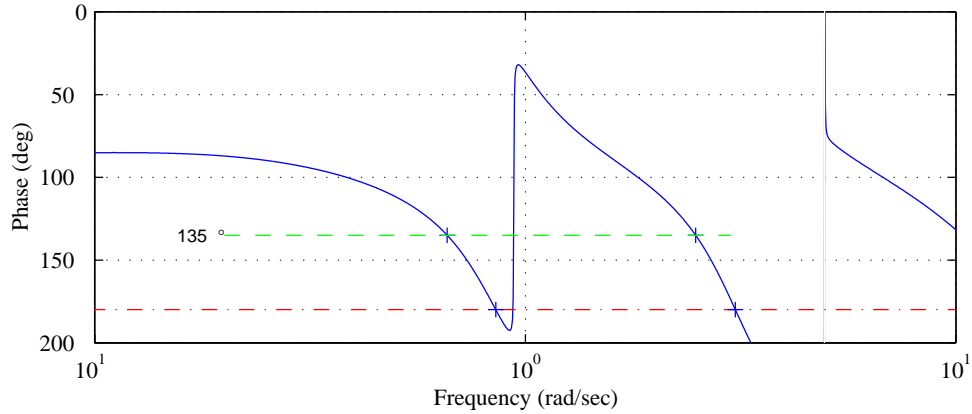
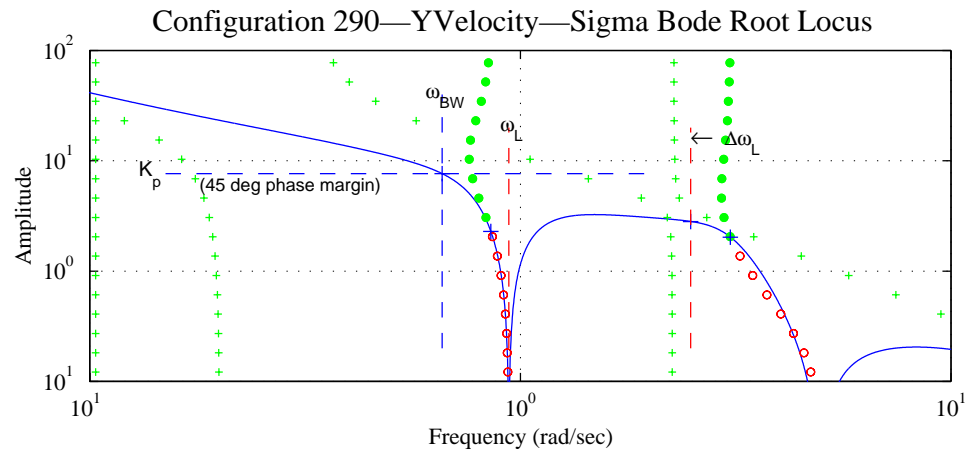

Figure D-50. Lateral Translational-Rate-Loop-Closure Characteristics – Configuration 240.



Transfer function: $\dot{y}/d_a =$
 $\frac{404.98 (0.103) (0.2) (2.25) [0.001 ; 4.96] [0.002 ; 0.94] <2.66e+003>}{(0.00146) (0.103) (0.32) (2.27) [0.283 ; 0.869] [0.261 ; 3.09] [0.500 ; 14]}$

$K_p = 0.131 \text{ deg/fps (45 deg phase margin)}$
 $\omega_{BW} = 0.659 \text{ rad/sec}$
 $\omega_{BW\phi1} = 0.659 \text{ rad/sec}$
 $\omega_{BW\phi2} = 0.836 \text{ rad/sec}$
 $\omega_{BWG1} = 0.777 \text{ rad/sec}$
 $\omega_{BWG2} = 0.795 \text{ rad/sec}$
 $\omega_L = 0.940 \text{ rad/sec}$
 $\Delta\omega_L = 1.545 \text{ rad/sec}$

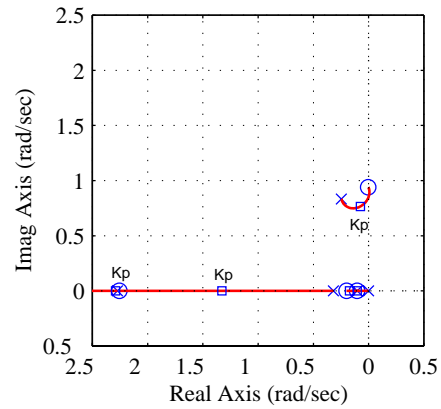
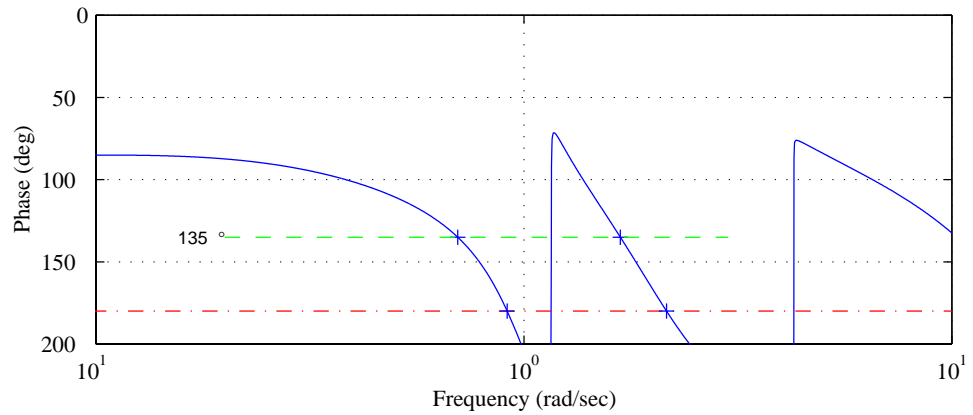
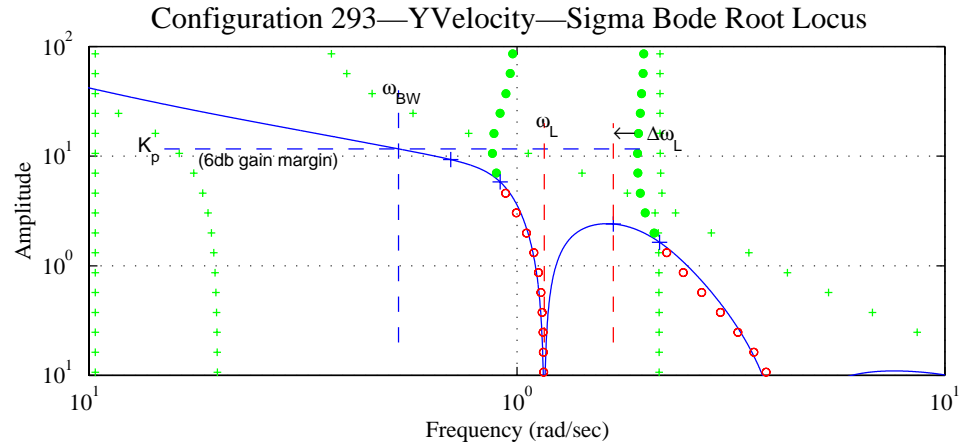

Figure D-51. Lateral Translational-Rate-Loop-Closure Characteristics – Configuration 290.



Transfer function: $\dot{y}/d_a =$
 $\frac{205.19 (0.103) (0.2) (2.15) [0.000 ; 4.27] [0.001 ; 1.16] \langle 2.13e+003 \rangle}{(0.00184) (0.103) (0.323) (2.16) [0.243 ; 1] [0.403 ; 2] [0.500 ; 14]}$

- $K_p = 0.086 \text{ deg/fps (6db gain margin)}$
- $\omega_{BW} = 0.529 \text{ rad/sec}$
- $\omega_{BW\phi1} = 0.700 \text{ rad/sec}$
- $\omega_{BW\phi2} = 1.045 \text{ rad/sec}$
- $\omega_{BWG1} = 0.529 \text{ rad/sec}$
- $\omega_{BWG2} = 1.012 \text{ rad/sec}$
- $\omega_L = 1.158 \text{ rad/sec}$
- $\Delta\omega_L = 0.522 \text{ rad/sec}$

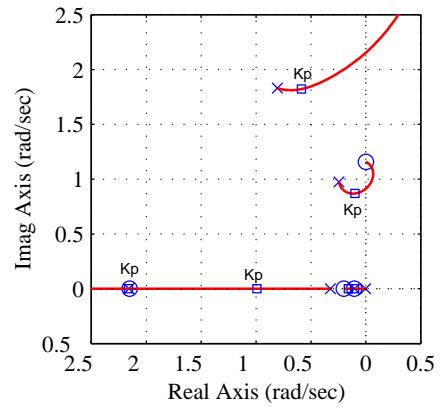
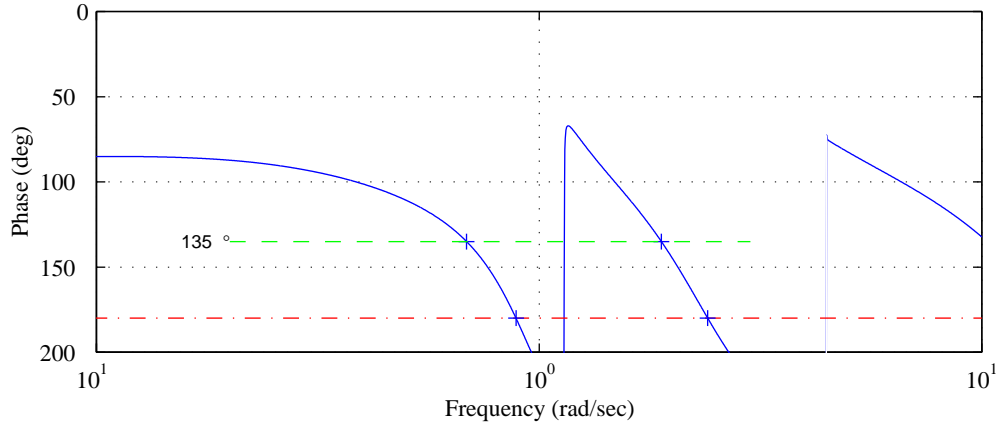
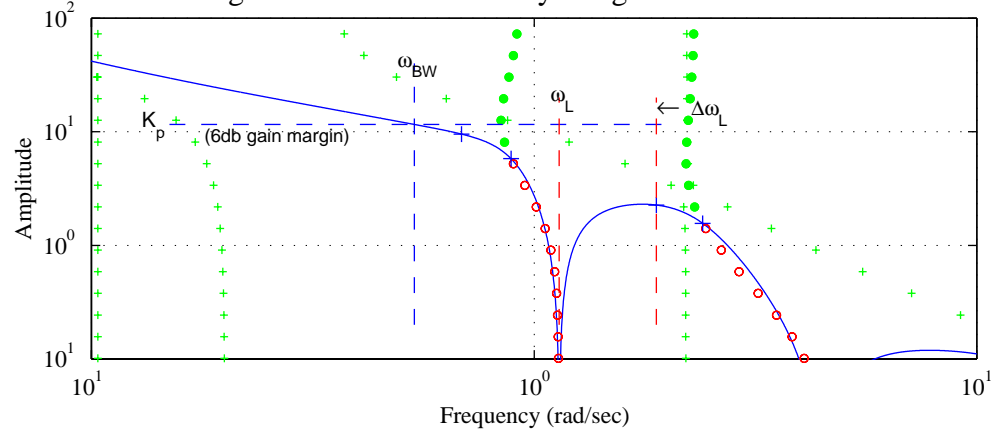

Figure D-52. Lateral Translational-Rate-Loop-Closure Characteristics – Configuration 293.

Configuration 294—YVelocity—Sigma Bode Root Locus



Transfer function: $y_{dot}/d_a =$
 $\frac{226.79 (0.103) (0.2) (2.2) [0.000 ; 4.46] [0.001 ; 1.14] <2.25e+003>}{(0.00174) (0.103) (0.32) (2.21) [0.258 ; 0.943] [0.349 ; 2.31] [0.500 ; 14]}$

- $K_p = 0.086 \text{ deg/fps (6db gain margin)}$
- $\omega_{BW} = 0.536 \text{ rad/sec}$
- $\omega_{BW\phi1} = 0.686 \text{ rad/sec}$
- $\omega_{BW\phi2} = 1.019 \text{ rad/sec}$
- $\omega_{BWG1} = 0.536 \text{ rad/sec}$
- $\omega_{BWG2} = 0.985 \text{ rad/sec}$
- $\omega_L = 1.140 \text{ rad/sec}$
- $\Delta\omega_L = 0.749 \text{ rad/sec}$

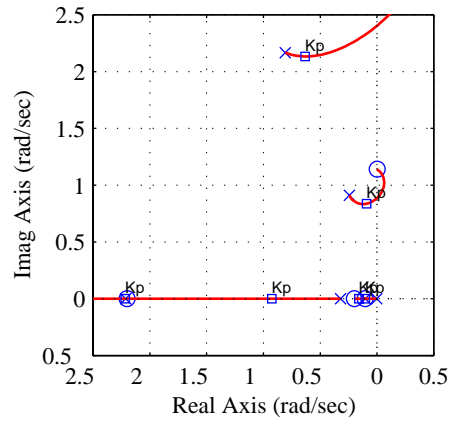

Figure D-53. Lateral Translational-Rate-Loop-Closure Characteristics – Configuration 294.

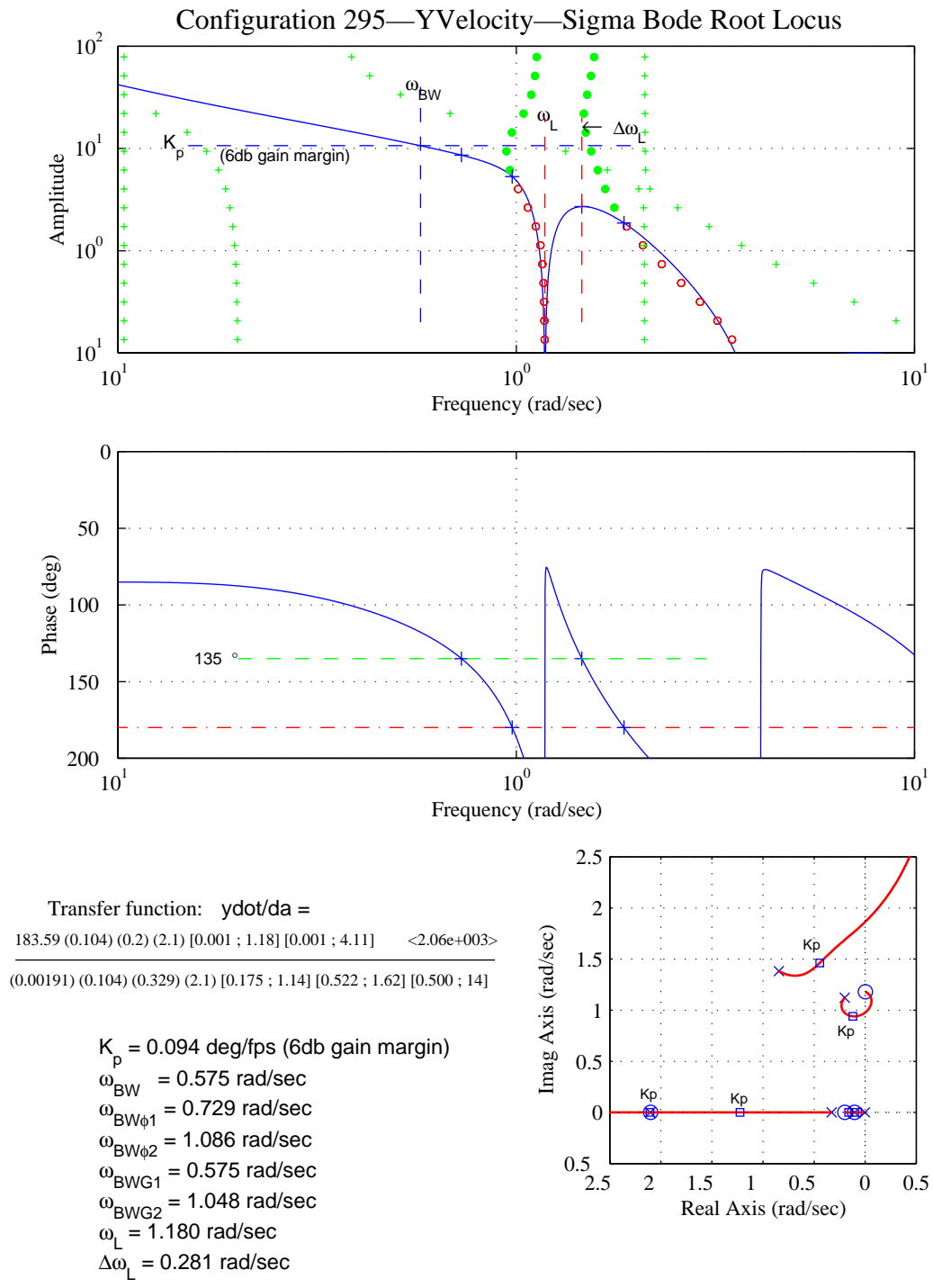
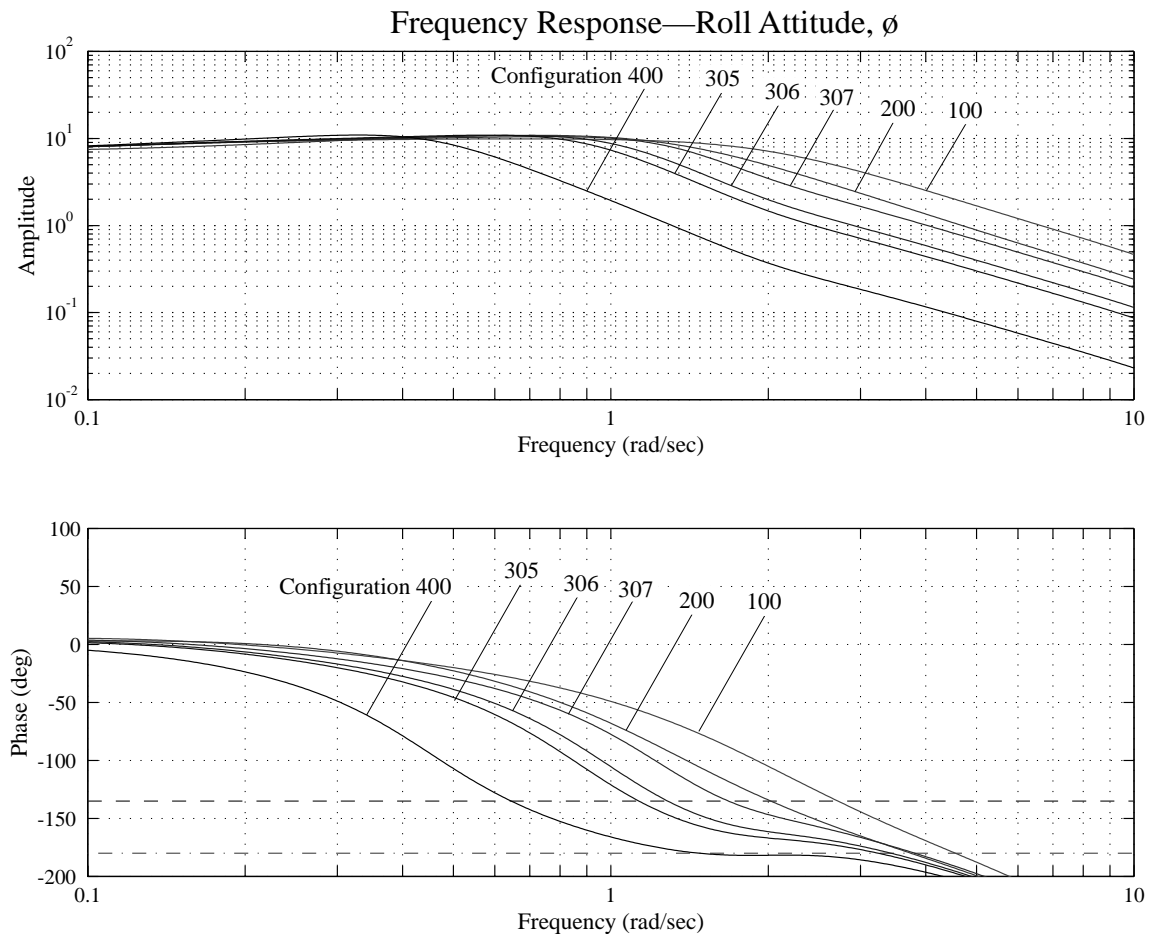

Figure D-54. Lateral Translational-Rate-Loop-Closure Characteristics – Configuration 295.

Appendix E – Attitude-Response Characteristics

A significant amount of effort was expended in this program to derive handling-qualities parameters based on the attitude-response characteristics (e.g., attitude bandwidth and phase delay). While this was not successful (e.g., see section 3.6), many useful insights were achieved from analyses of the pitch and roll attitude responses to control inputs. Some of the more insightful results from that work are documented in this appendix. In addition, some of the shortfalls of attitude bandwidth as a handling qualities parameter for rotorcraft with an external load are illustrated.

Figure E-1 shows tested variations in roll attitude bandwidth with load off for the various SCAS configurations, ranging from a high of 2.60 rad/sec for configuration 100 (ACAH1) down to 0.70 rad/sec for configuration 400 (ACAH4). Attitude bandwidth is defined here by the frequency where the phase passes through -135 deg.



5/ 5/1998

Figure E-1. Frequency Response of Bank Angle with Lateral Control for Varying SCAS Bandwidth.

E.1 Effect of Load Mass on Roll-Attitude Response

It was shown in section 3.3 that load mass had a very pronounced effect on handling qualities. Those results indicated that the handling qualities are degraded monotonically with increasing load mass relative to the basic load-off configuration.

Figure E-2 is a plot of the frequency response of roll attitude to lateral cyclic. It illustrates the effect of load mass on roll-attitude bandwidth for the various load-mass configurations, ranging from 4,000 to 27,600 lb, with a total weight of 46,000 lb. Increasing the load mass has only a small effect on the attitude bandwidth and a much more significant effect on the pendulum frequency. The pendulum effect is visible in the amplitude dips that correspond to the transfer-function complex zeros. That is, at the pendulum frequency, the load has essentially no effect on the aircraft roll attitude.

Note that the secondary phase hump observed in the translational rate response also occurs in the roll-attitude response. However, attempts to correlate the pilot rating data with a load-coupling parameter defined for attitude ($\Delta\omega_{L\phi}$) were not successful (see section 2.3, fig. 5 for a description of the load-coupling parameter).

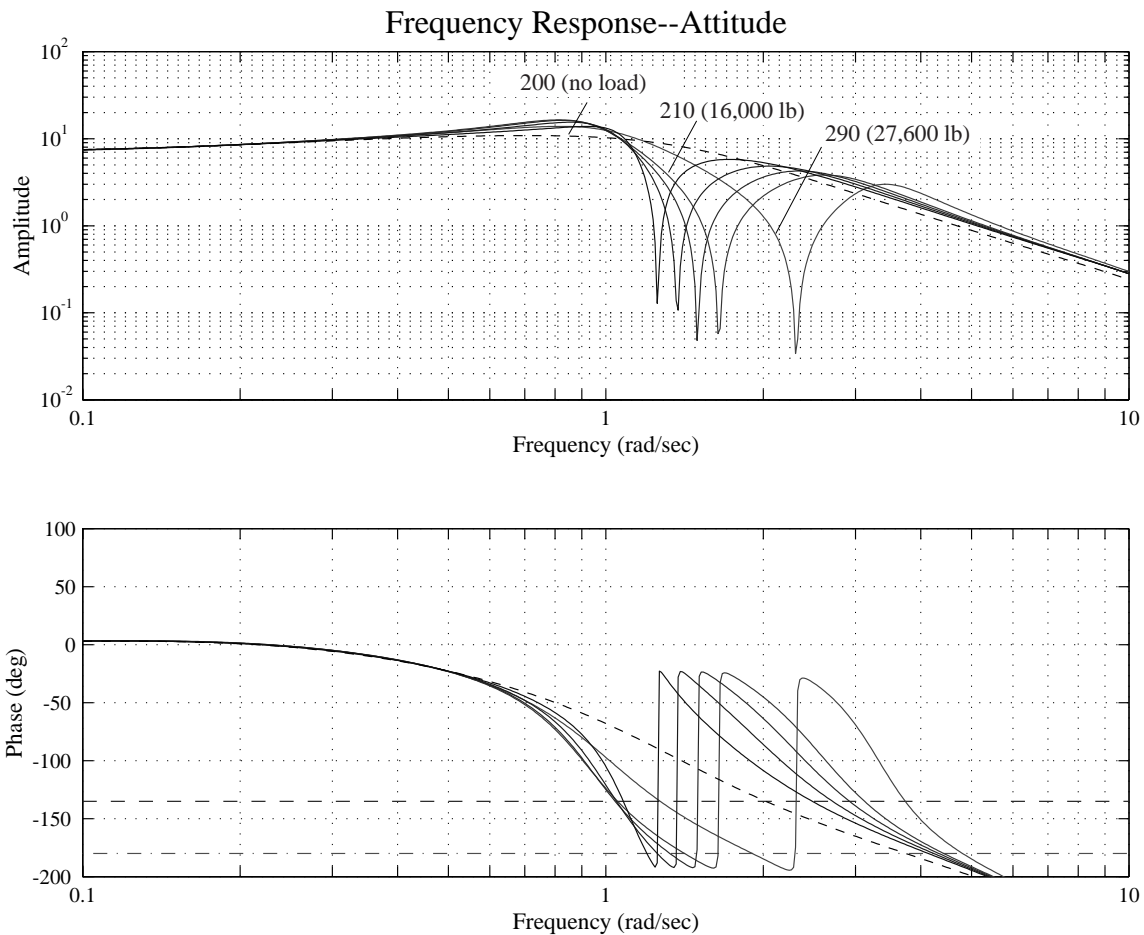

5/ 6/1998

Figure E-2. Frequency Response of Bank Angle with Lateral Control for Varying Load-Mass Ratios.

Figure E-3 shows how dominant modes vary with increasing load-mass ratio. Note that the main features of the response are a single complex zero pair and two complex pole pairs. The poles represent the body response and the load pendulum motion response. As the load-mass ratio increases, the pole-zero separation increases, mode damping decreases, and the quality of the overall response degrades.

Consider the 4,000-lb load. The load-pendulum response mode is nearly cancelled by the complex zero and the body mode is well damped, indicating that the effect of the load on the roll response is small. At the other extreme, the 28,000-lb load results in a wide separation between the complex zero and load mode pole, indicating that the swinging load has a significant effect on the roll response. Furthermore, the damping is low in both modes. Hence the overall quality of the roll response is poor, because of the large nuisance oscillation from the pendulum mode.

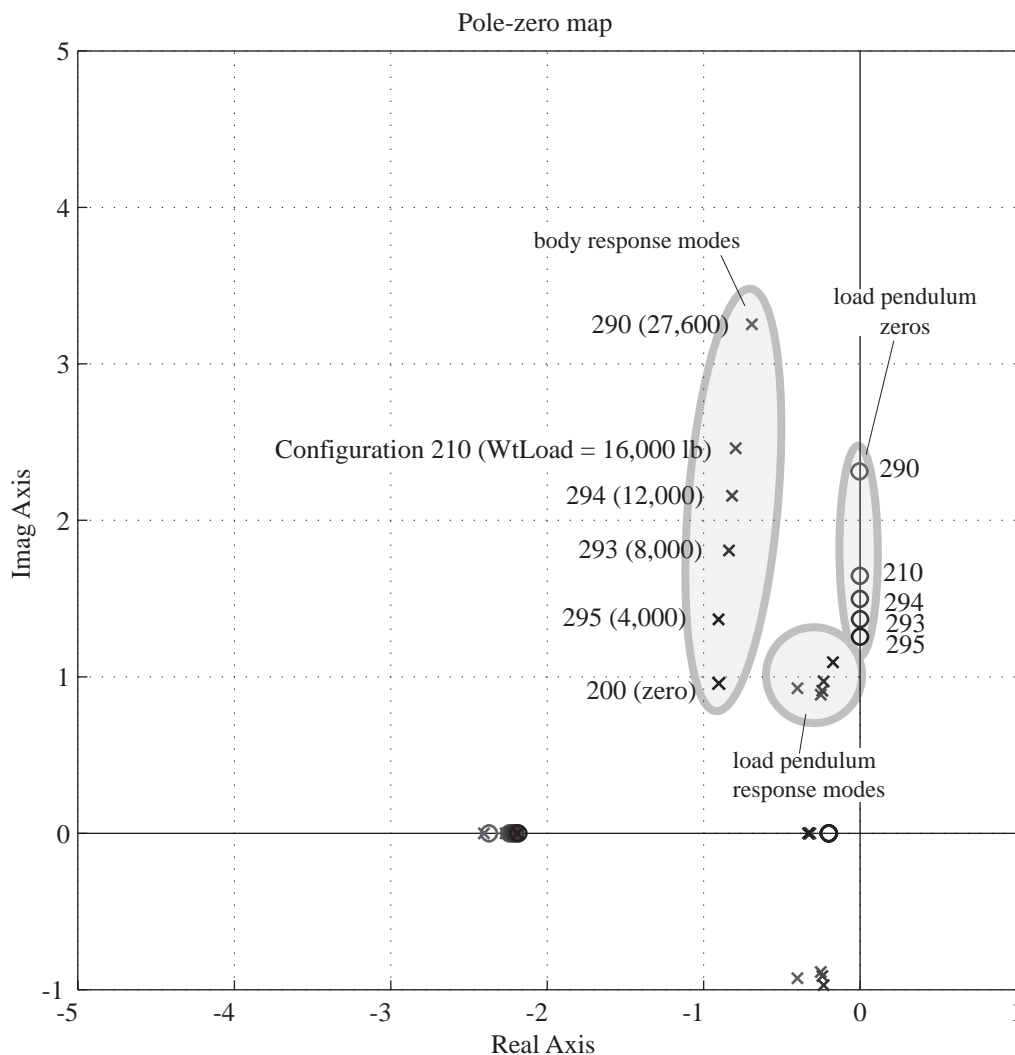

Figure E-3. Pole-Zero Migration with Variation of Load-Mass Ratio.

E.2 Effect of Hook-to-C.G. Distance

The effect of hook-to-c.g. vertical offset on pilot ratings is substantial, particularly at smaller values of vertical offset. Figure E-4 indicates a similar trend, as identified through analysis of the translational velocity response – very small values of hook-to-c.g. distance result in poor handling qualities, and the fact that a distance of 7 ft is approximately optimum for the CH-47 (see fig. 14).

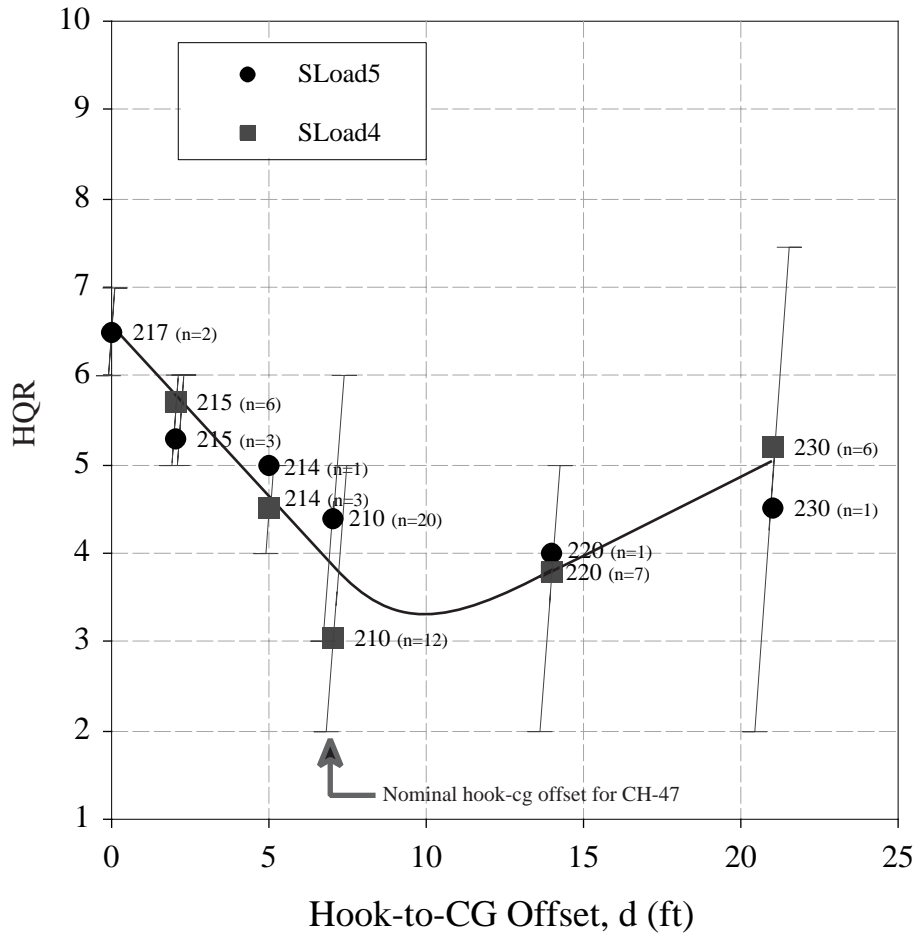
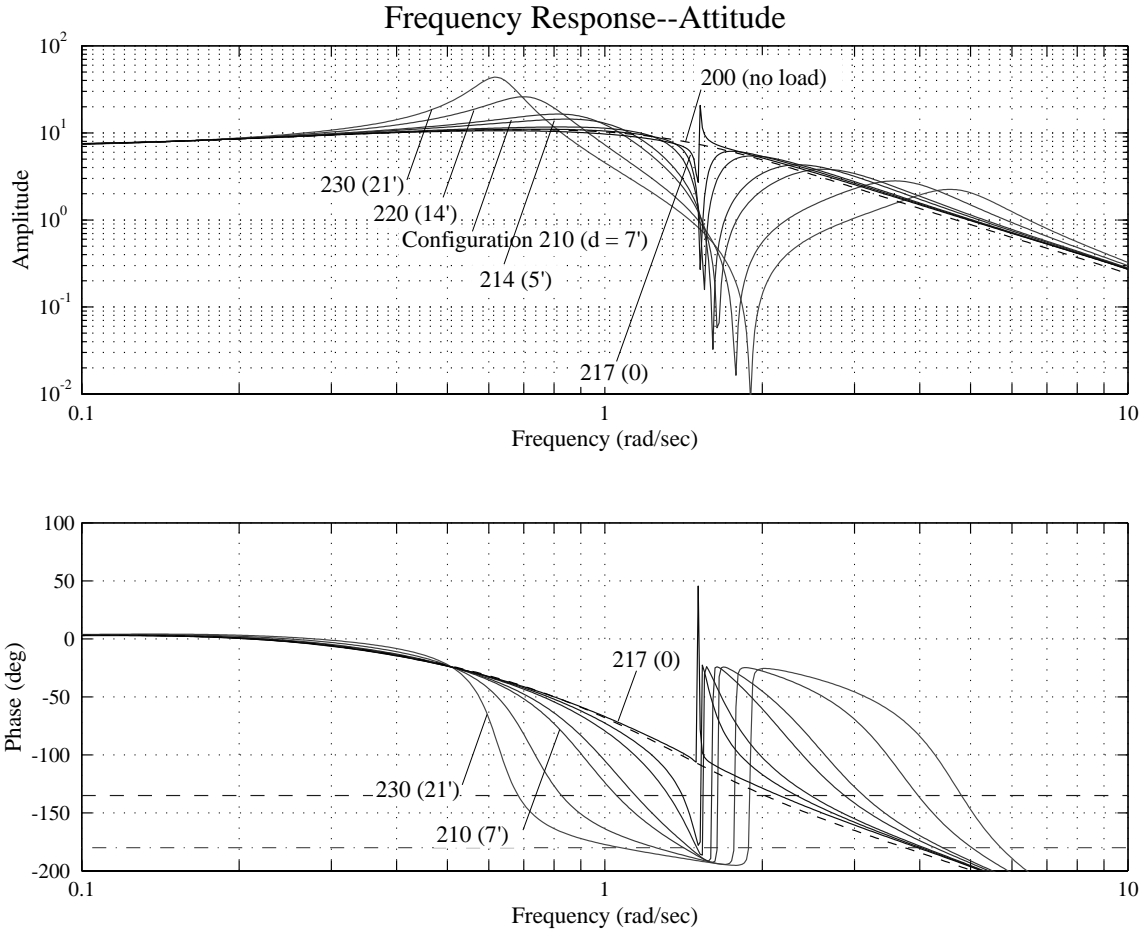

Figure E-4. HQRs for Varying Hook-C.G. Distance.

Figures E-5 and E-6 show how vehicle response varies with hook-to-c.g. offset using the medium-bandwidth SCAS (ACAH2 or configuration 200) as a baseline.

Figure E-5 shows the direct influence of the hook-to-c.g. distance on the roll-attitude response.



5/ 5/1998

Figure E-5. Frequency Response of Bank Angle with Lateral Control for Varying Hook-to-C.G. Offset.

Figure E-6 shows how roll-attitude control poles and zeros vary with hook-to-c.g. offset. For hook-to-c.g. distances over 7 ft the pole-zero distance becomes large, indicating a significant response due to the swinging load. In addition, the basic aircraft mode becomes lightly damped (almost neutrally stable at $l_{hook} = 21$ ft).

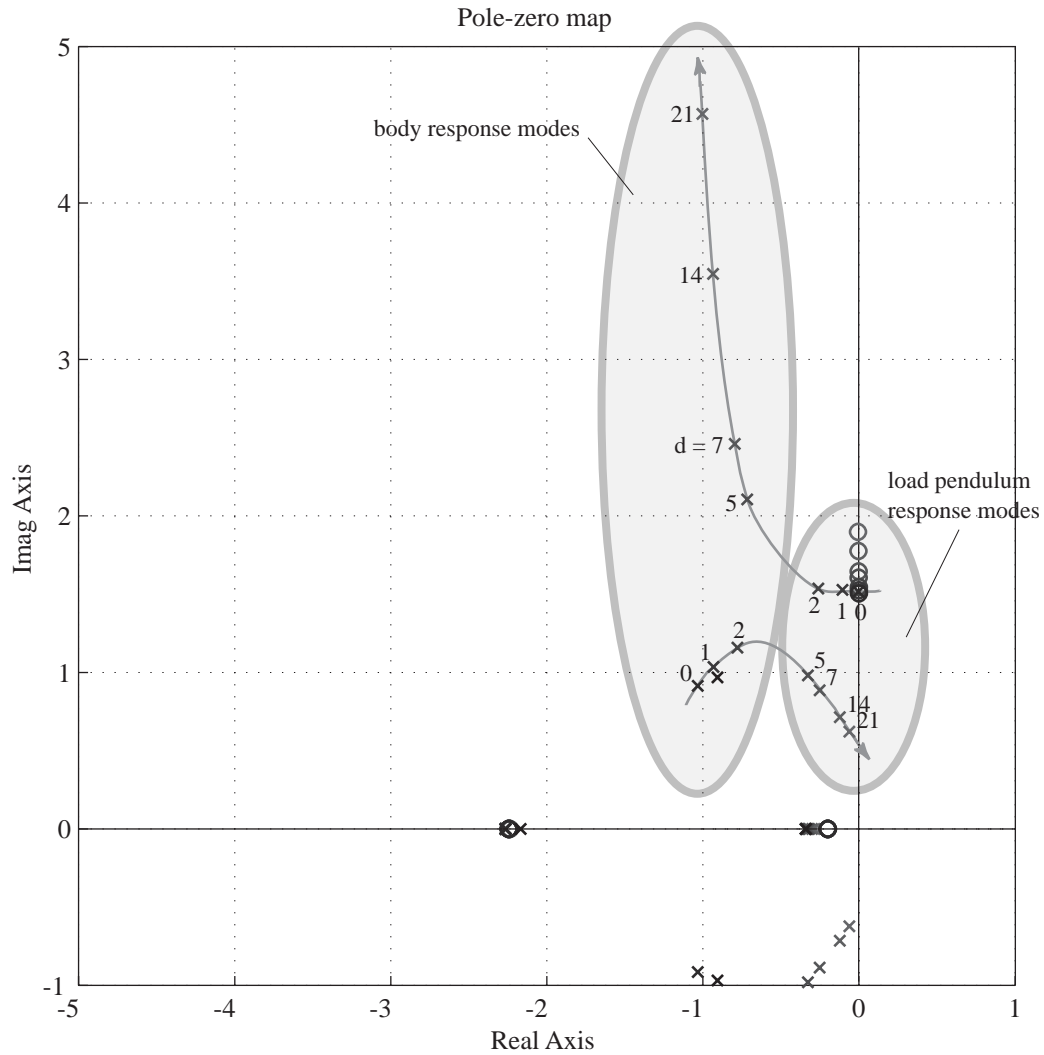

Figure E-6. Pole-Zero Migration for Varying Hook-to-C.G. Offset.

E.3 Effect of Sling Length

The length of the external load sling was not found to be a major factor in determining handling qualities. Figure E-7 shows the weak effect of sling length on HQRs. There is a mild degradation in ratings of about 1/2 rating point over the nearly order-of-magnitude change in sling length.

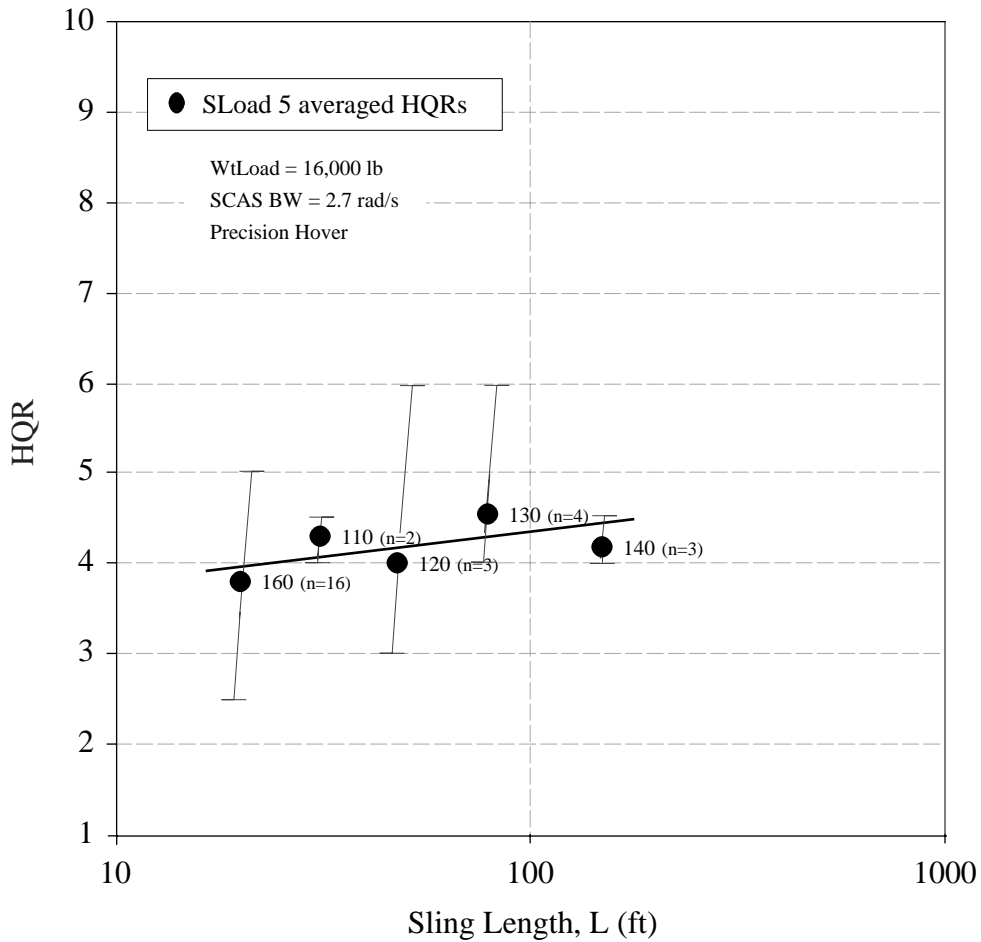
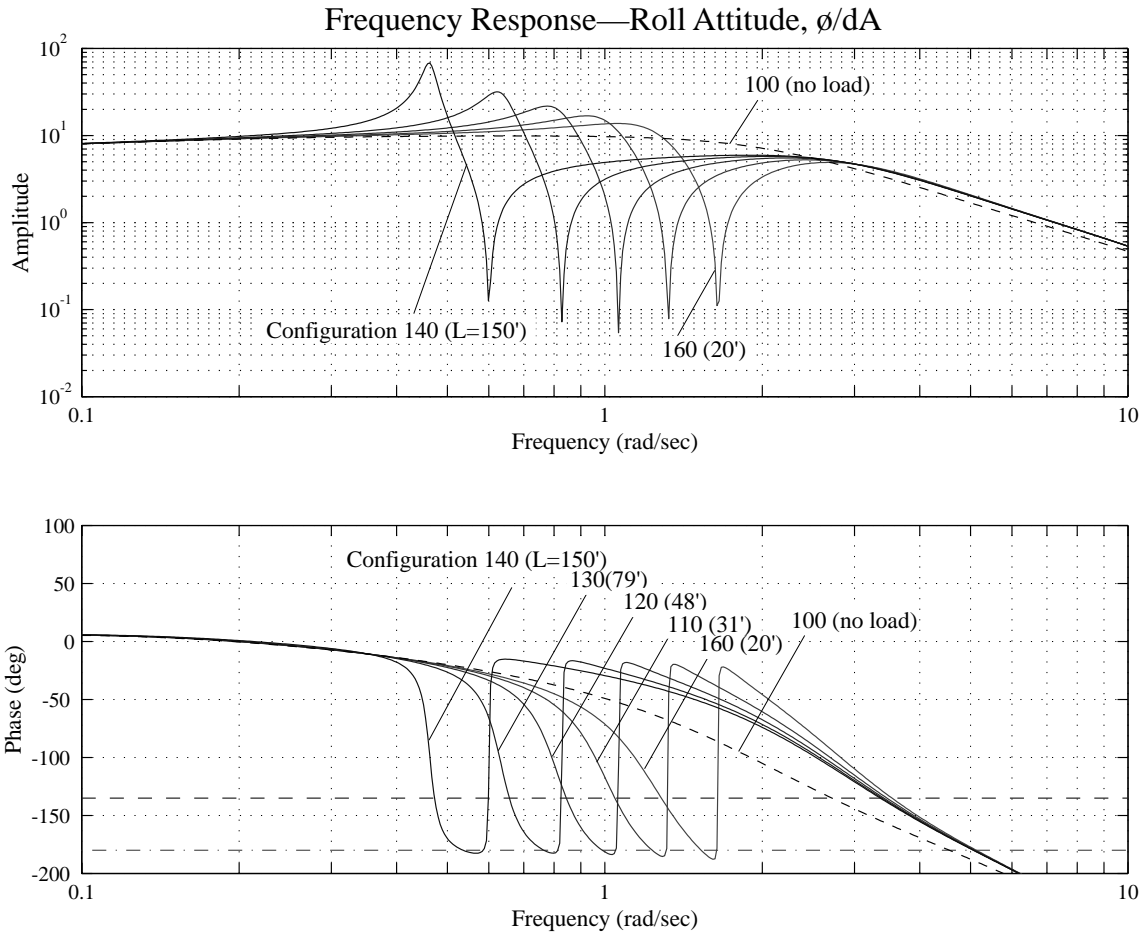

Figure E-7. HQR as a Function of Sling Length.

The main dynamic effect is the decrease in pendulum frequency as length increases, resulting in a significant reduction in “load-on bandwidth,” as shown in figure E-8. The fact that this bandwidth is strongly dependent on sling length, whereas the pilot ratings are not, provides evidence that this parameter is not a good choice as a handling-qualities metric.



5/ 5/1998

FigureE-8. Frequency Response of Bank Angle with Lateral Control for Varying Sling Length.

The effect of sling length on the pole-zero locations is illustrated in figure E-9.

Although long sling lengths produce low pendulum damping, there is effective cancellation of the mode by the associated complex zero, minimizing the amplitude of the load swing on roll attitude as the pilot maneuvers.

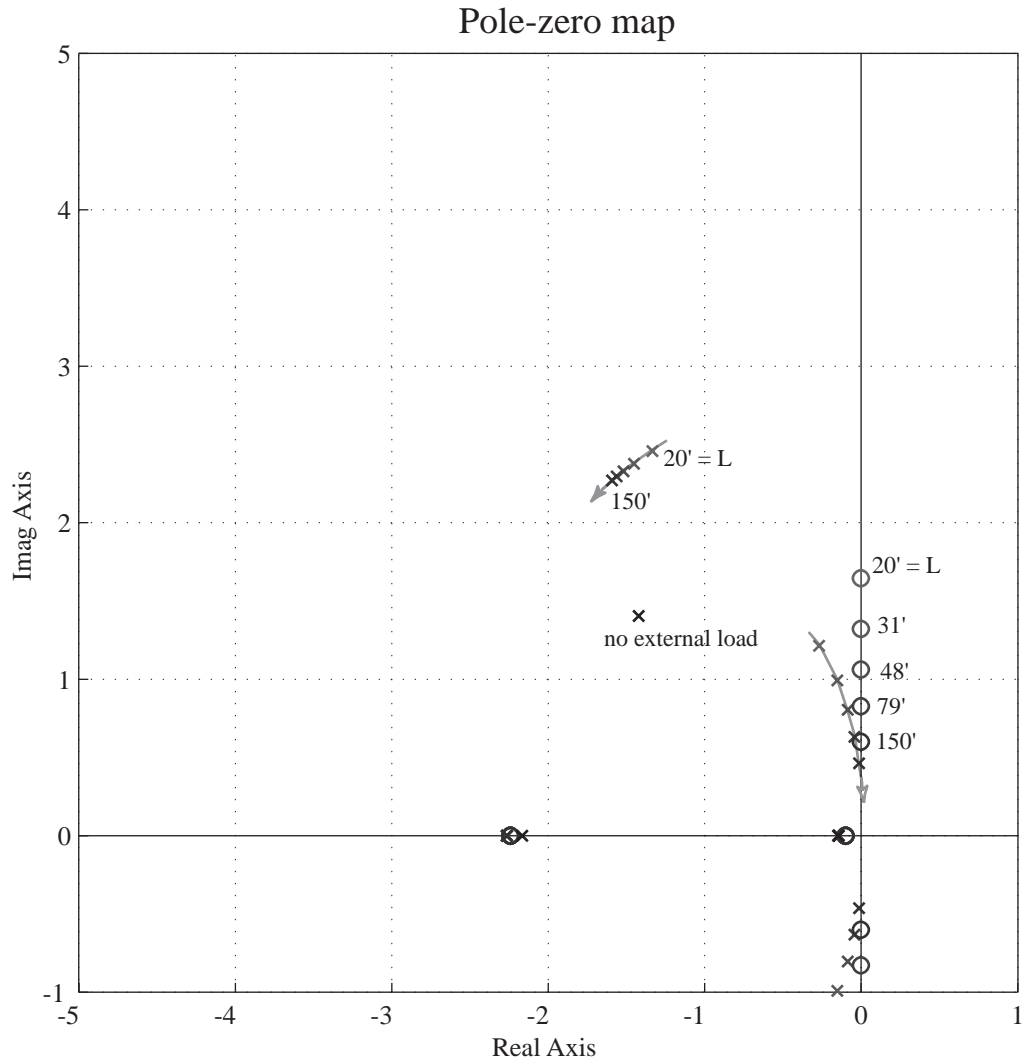

Figure E-9. Pole-Zero Locations as a Function of Sling Length.

REPORT DOCUMENTATION PAGE

Form Approved
OMB No. 0704-0188

The public reporting burden for this collection of information is estimated to average 1 hour per response, including the time for reviewing instructions, searching existing data sources, gathering and maintaining the data needed, and completing and reviewing the collection of information. Send comments regarding this burden estimate or any other aspect of this collection of information, including suggestions for reducing this burden, to Department of Defense, Washington Headquarters Services, Directorate for Information Operations and Reports (0704-0188), 1215 Jefferson Davis Highway, Suite 1204, Arlington, VA 22202-4302. Respondents should be aware that notwithstanding any other provision of law, no person shall be subject to any penalty for failing to comply with a collection of information if it does not display a currently valid OMB control number.

PLEASE DO NOT RETURN YOUR FORM TO THE ABOVE ADDRESS.

1. REPORT DATE (DD-MM-YYYY) 18-10-2006			2. REPORT TYPE Contractor Report		3. DATES COVERED (From - To) 1997-2001	
4. TITLE AND SUBTITLE Development of Handling Qualities Criteria for Rotorcraft with Externally Slung Loads				5a. CONTRACT NUMBER NAS2-14360		
				5b. GRANT NUMBER		
				5c. PROGRAM ELEMENT NUMBER		
6. AUTHOR(S) Roger H. Hoh, Robert K. Heffley, and David G. Mitchell				5d. PROJECT NUMBER		
				5e. TASK NUMBER		
				5f. WORK UNIT NUMBER		
7. PERFORMING ORGANIZATION NAME(S) AND ADDRESS(ES) Hoh Aeronautics, Inc., 2075 Palos Verdes Drive North #217, Lomita, California 90717 and Aeroflightdynamics Directorate, U.S. Army Research, Development, and Research Command, Moffett Field, California 94035-1000				8. PERFORMING ORGANIZATION REPORT NUMBER A-060008		
9. SPONSORING/MONITORING AGENCY NAME(S) AND ADDRESS(ES) National Aeronautics and Space Administration, Washington, D.C. 20546-0001 and Aviation & Missile Research, Development, and Engineering Center U.S. Army Research, Development, and Engineering Command, Redstone Arsenal Huntsville, AL 35898				10. SPONSORING/MONITOR'S ACRONYM AFDD / NASA		
				11. SPONSORING/MONITORING REPORT NUMBER AFDD/TR-06-003, NASA CR2006-213488		
12. DISTRIBUTION/AVAILABILITY STATEMENT Unclassified — Unlimited (UU) Distribution: Non-Standard Subject Category — 08, 05 Available from NASA CASI. (301) 621-0390						
13. SUPPLEMENTARY NOTES Point of contact: Chris L. Blanken, AFDD, M/S: T12B-2, Moffett Field, CA 94035-1000						
14. ABSTRACT Piloted simulations were performed on the NASA-Ames Vertical Motion Simulator (VMS) to explore handling qualities issues for large cargo helicopters, particularly focusing on external slung load operations. The purpose of this work was based upon the need to include handling qualities criteria for cargo helicopters in an upgrade to the U.S. Army's rotorcraft handling qualities specification, Aeronautical Design Standard-33 (ADS-33E-PRF). From the VMS results, handling qualities criteria were developed for cargo helicopters carrying external slung loads in the degraded visual environment (DVE). If satisfied, these criteria provide assurance that the handling quality rating (HQR) will be 4 or better for operations in the DVE, and with a load mass ratio of 0.33 or less. For lighter loads, flying qualities were found to be less dependent on the load geometry and therefore the significance of the criteria is less. For heavier loads, meeting the criteria ensures the best possible handling qualities, albeit Level 2 for load mass ratios greater than 0.33.						
15. SUBJECT TERMS Helicopter, handling qualities, criteria, ADS-33, external slung loads, bandwidth.						
16. SECURITY CLASSIFICATION OF:			17. LIMITATION OF ABSTRACT	18. NUMBER OF PAGES	19a. NAME OF RESPONSIBLE PERSON	
a. REPORT	b. ABSTRACT	c. THIS PAGE			Chris L. Blanken	
Unclassified	Unclassified	Unclassified	UU	168	19b. TELEPHONE NUMBER (Include area code) (650) 604-5836	

