

INTER-NOISE 2006

3-6 DECEMBER 2006

HONOLULU, HAWAII, USA

Development of experimental and computational aeroacoustic tools for advanced liner evaluation

Michael G. Jones^a

NASA Langley Research Center
Hampton, VA 23681-2199
USA

Willie R. Watson^c

NASA Langley Research Center
Hampton, VA 23681-2199
USA

Douglas M. Nark^e

NASA Langley Research Center
Hampton, VA 23681-2199
USA

Tony L. Parrott^b

NASA Langley Research Center
Hampton, VA 23681-2199
USA

Carl H. Gerhold^d

NASA Langley Research Center
Hampton, VA 23681-2199
USA

Martha C. Brown^f

NASA Langley Research Center
Hampton, VA 23681-2199
USA

ABSTRACT

Acoustic liners in aircraft engine nacelles suppress radiated noise. Therefore, as air travel increases, increasingly sophisticated tools are needed to maximize noise suppression. During the last 30 years, NASA has invested significant effort in development of experimental and computational acoustic liner evaluation tools. The Curved Duct Test Rig is a 152-mm by 381-mm curved duct that supports liner evaluation at Mach numbers up to 0.3 and source SPLs up to 140 dB, in the presence of user-selected modes. The Grazing Flow Impedance Tube is a 51-mm by 63-mm duct currently being fabricated to operate at Mach numbers up to 0.6 with source SPLs up to at least 140 dB, and will replace the existing 51-mm by 51-mm duct. Together, these test rigs allow evaluation of advanced acoustic liners over a range of conditions representative of those observed in aircraft engine nacelles. Data acquired with these test ducts are processed using three aeroacoustic propagation codes. Two are based on finite element solutions to convected Helmholtz and linearized Euler equations. The third is based on a parabolic approximation to the convected Helmholtz equation. The current status of these computational tools and their associated usage with the Langley test rigs is provided.

1 NOMENCLATURE

k, t, ω	free-space wavenumber, time and angular frequency
u, v	acoustic particle velocities in axial and vertical directions
x, y, z	vertical, spanwise and axial coordinates
p, M_0	acoustic pressure and mean flow Mach number
ρ_0, c_0	mean density and sound speed
ξ, ξ_{exit}	surface and exit impedances (normalized by $\rho_0 c_0$)

Note: An $e^{i\omega t}$ convention is used throughout this paper.

^a Email address: Michael.G.Jones@nasa.gov

^b Email address: Tony.L.Parrott@nasa.gov

^c Email address: Willie.R.Watson@nasa.gov

^d Email address: Carl.h.Gerhold@nasa.gov

^e Email address: Douglas.M.Nark@nasa.gov

^f Email address: Martha.C.Brown@nasa.gov

2 INTRODUCTION

Further reduction of aircraft noise experienced by commercial airport communities, in the face of ever increasing airport traffic, is critically dependent upon aircraft engine technology evolution. The bypass ratio for commercial aircraft engines has continually increased during the last four decades, from about 1.4 in the 1960s to about 10 in recent engine designs, to achieve increased thrust with a decrease in jet velocity. As a result, jet noise has been reduced and replaced by fan noise as the dominant engine noise source. Simultaneously, the nacelle length has been reduced, such that inlet length-to-diameter ratios of less than 0.5 are becoming common. Because noise attenuation is directly proportional to lined length-to-duct diameter ratio, acoustic liner efficiency must increase just to maintain the same noise reduction. Design requirements are therefore becoming increasingly stringent, resulting in a need for increasingly sophisticated tools to maximize noise suppression from the available acoustically treated area.

A number of facilities, together with supporting analytical/computational methodologies, have been used to evaluate acoustic liners. [1,2] Four notable facilities are those owned by General Electric, Goodrich Aerostructures, Spirit Aerosystems and United Technologies Research Center. General Electric used a 127-mm by 102-mm (5"x4") duct (no longer in use) to measure DC flow resistance (for both suction and blowing through test specimen) in the presence of grazing flow at Mach numbers as high as 0.7. The resultant flow resistances were then used to estimate the acoustic resistance of the material. Goodrich Aerostructures acquires insertion loss data in a 140-mm by 102-mm (5.5"x4") flow duct connected to two reverberation chambers. A 2-D mode propagation model is used to determine the test liner acoustic impedance by iterating the impedance boundary condition (test liner impedance) to achieve an acceptable match between predicted and measured insertion losses. Spirit Aerosystems uses a 51-mm by 51-mm (2"x2") duct (note: this facility previously belonged to Boeing), in which the upper and lower walls are formed by a test liner surface and a traversing teflon strip, respectively. An electro-pneumatic driver is used to generate an acoustic signal, and a microphone flush-mounted in the teflon strip is traversed over the test liner length to measure the acoustic pressure profile. A multi-mode, segmented-liner, aeroacoustic propagation model is used to predict the acoustic pressure profile for a series of liner impedances, and the impedance for which the measured and predicted acoustic pressure profiles are matched is assumed to be the "true" liner impedance. The United Technologies Research Center uses a 51-mm by 127-mm (2"x5") flow duct for liner evaluation. This facility uses the *In-Situ* method [3] (i.e. embedding of microphones into a "patch" of liner) to obtain the "local" acoustic impedance (i.e., the impedance in the vicinity of the surface patch).

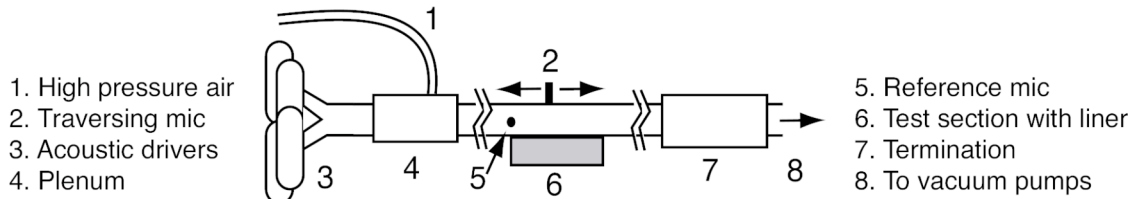

Figure 1. Sketch of NASA Grazing Incidence Tube (GIT, with traversing microphone)

During the last 30 years, NASA Langley has invested significant effort on experimental tool development for evaluation of acoustic liner concepts. A 51-mm by 51-mm (2"x2") flow impedance tube (figures 1, 2) was implemented during the 1970s that relied on a single, flush-mounted, traversing microphone (derivative of Spirit Aerosystems approach) to determine the acoustic pressure profile over the length of the liner (and, consequently, its acoustic impedance).

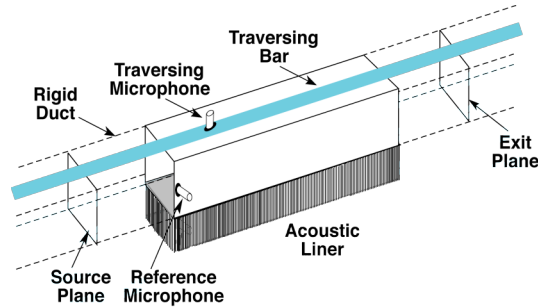

Figure 2. Sketch of NASA Grazing Incidence Tube (GIT) test window (with traversing microphone)

In the mid-1990s, this duct was upgraded (Grazing Incidence Tube; GIT) to employ 95 fixed microphones (see figure 3) to replace the single, traversing microphone. This allowed a more complete acoustic pressure profile (including higher-order mode contributions) to be acquired much more efficiently (factor of 10 efficiency increase). During the last year, designs for further

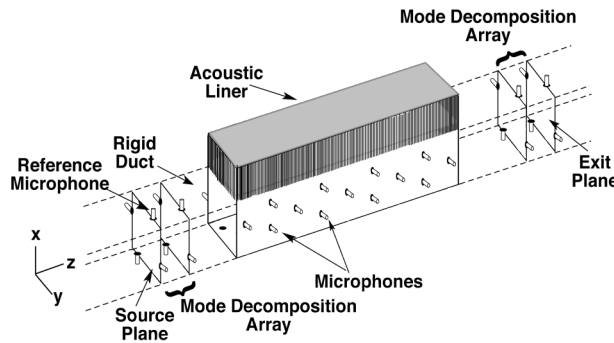

Figure 3. Sketch of NASA Grazing Incidence Tube (GIT) test window (with 95 microphones)

enhancements have been completed, and fabrication has been initiated, for a 51-mm by 63-mm (2"x2.5") flow impedance tube (figure 4). This Grazing Flow Impedance Tube (GFIT) is intended to provide increased flow capability for inlet and aft-duct liner evaluation, and a means to include the boundary layer as a test parameter. In addition, the 152-mm by 381-mm (6"x15") Curved Duct Test Rig (CDTR, figure 5) has also been brought on-line during the last two years. The key feature of the CDTR is to allow the effects of liner curvature to be evaluated in the presence of flow and a single, user-selected mode. Liner curvature is controlled with end-to-end offsets ("S-shaped geometry") of zero to one duct diameter (152 mm). Together, these test rigs allow critical, parametric investigations of advanced acoustic liners over a range of conditions representative of those observed in aircraft engine nacelles.

NASA Langley has also invested significant effort in the continual improvement of computational methods for acoustic liner evaluation. [4-11] The overarching goal has been the development of a suite of computational methods, in which the required level of effort (both

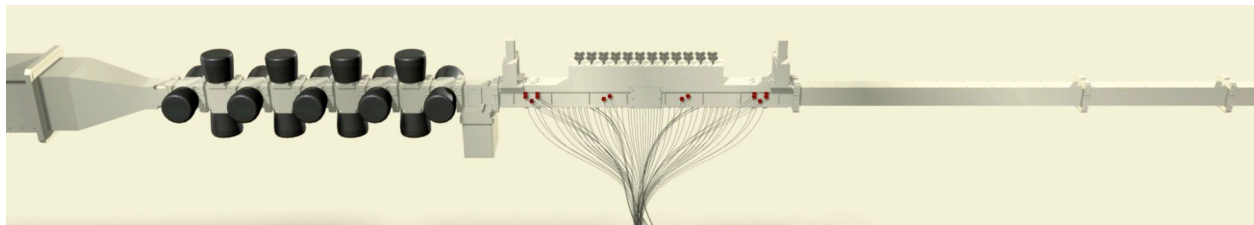

Figure 4. Sketch of NASA Grazing Flow Impedance Tube (GFIT) with aft-duct liner configuration

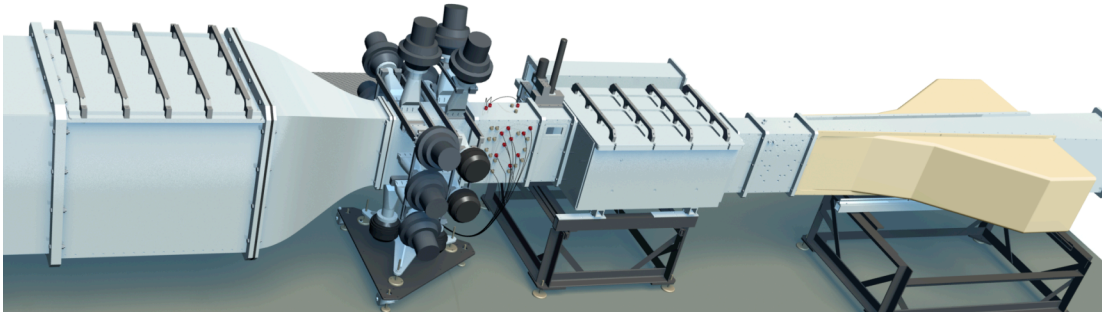

Figure 5. Sketch of NASA Curved Duct Test Rig (CDTR)

experimental and computational) is commensurate with the fidelity needed for a particular application. For the sake of brevity, only the more recent computational method advances are discussed in this report. Of particular note are the aeroacoustic propagation/impedance reduction codes labeled as 3DFEM, LaRC-LEE and CDUCT-LaRC.

The “workhorse” code for impedance reduction, 3DFEM, [10] makes use of acoustic pressure data acquired in the GIT. It is based on a finite element solution of the convected Helmholtz equation. The code “seeks” the liner impedance that “causes a match” between computed and measured acoustic pressure profiles on the wall opposite the test liner. Although this method has been thoroughly tested for 2-D applications (i.e., restricted to data on the wall opposite of the liner), it is designed to handle fully 3-D acoustic fields. However, this code is restricted to uniform mean flow. To allow investigation of shear layer effects, a new code (LaRC-LEE) based on a finite element solution of the linearized Euler equations has been recently implemented. [10] In addition, another code (CDUCT-LaRC) based on a parabolic approximation to the convected Helmholtz equation has been implemented. [11] CDUCT-LaRC does not handle reflections, and the accuracy of the solutions is reduced as the propagation direction diverges from the preferred propagation angle. However, it is very efficient, allowing solutions for complex 3-D geometries to be handled with relatively low computational costs. Together, these codes provide a strong basis for tradeoffs between computational expense and solution fidelity.

This paper provides a discussion of advanced experimental and computational tools currently used at NASA Langley Research Center for acoustic liner evaluation. It also provides a description of additional enhancements currently in progress.

3 NASA LANGLEY AEROACOUSTIC TEST RIGS

NASA Langley currently employs two flow ducts for acoustic liner evaluation, the GIT and CDTR. The GFIT is scheduled to replace the GIT in early 2007, and will be followed by upgrades to the CDTR. Table 1 shows salient differences among these test ducts.

Table 1: NASA Langley flow ducts for acoustic liner evaluation (CDTR enhancements in parentheses)

Flow Duct	Cross-section, mm	Mach Number	Frequency, kHz	Test Liner Max Length, mm
GIT	51x51	0.0 - 0.5	0.4 – 3.0	406
GFIT	51x63	0.0 - 0.6	0.4 – 6.0	610
CDTR	152x381	0.0 - 0.3 (0.5)	0.3 – 2.4 (3.4 after upgrade)	813*

*straight duct configuration

3.1 Grazing Incidence Tube (GIT)

The NASA Langley Grazing Incidence Tube (GIT, Figure 3) is a 51-mm by 51-mm (2"x2") flow impedance tube. The test liner (maximum length, 406 mm) forms a portion of the upper wall of this flow duct. The test liner is axially centered in the 812-mm test section and the remainder of the GIT consists of rigid duct to connect to an upstream flow-conditioning system and a downstream, near-anechoic termination. Centerline mean flow Mach numbers up to 0.5 are achieved in the GIT. Four electromagnetic acoustic drivers provide acoustic excitation and the 95-microphone test window acquires the acoustic pressure profile over the length of the test section. Only plane waves are supported in the hardwall sections for frequencies up to approximately 3.0 kHz (depending on mean flow Mach number). For this frequency range, only the 31 microphones on the lower wall (opposite the test liner) are needed for impedance education. The additional microphones are positioned to support an analysis bandwidth upper limit of 10.0 kHz, to include higher-order modes. This design was implemented to support full usage of the 3-D finite element method (3DFEM) described in section 4 below.

Digitized acoustic pressure data are acquired simultaneously on 48 of the 95 microphones, and a switch matrix is used to acquire the second set of 48 (both sets have a reference microphone in common). For typical data acquisition, 2000 averages are implemented on each microphone channel (blocks of 2048 data points per average). Flow noise is excluded via a cross-spectrum signal extraction method [12] that provides transfer functions relative to the reference microphone location. The number of averages is chosen to handle "worst case" signal-to-noise ratios (i.e., high flow speed, low acoustic excitation). The system allows a complete liner evaluation (4 Mach numbers, 6 test frequencies) to be completed within four hours.

3.2 Grazing Flow Impedance Tube (GFIT)

Designs for a new Grazing Flow Impedance Tube (GFIT, Figures 4, 6 and 7) have recently been completed, and fabrication is in progress for a planned start-up in early 2007. This new 51-mm by 63-mm (2"x2.5") duct is intended to provide increased flow capability for inlet and aft-duct liner evaluation. It will also provide a methodology for conveniently evaluating the effects of boundary layer thickness on the acoustic performance of acoustic liners. By combining a high-pressure air supply on the upstream end, and a high mass flow vacuum pump on the downstream end, the test window will experience ambient conditions with mean flow velocities up to at least Mach 0.6. At the air supply end, a diffuser-plenum-convergence section is designed to provide minimal acoustic reflection for upstream propagating waves and low-turbulence, uniform flow at the test duct entrance by acoustically treating the diffuser and providing a contoured (catenoidal shape) convergence section. At the downstream end of the test duct, another acoustically treated diffuser is used to couple the exiting aeroacoustic wave system to the high mass-flow vacuum pump, with minimal reflection back into the test duct. The acoustic source will be provided by a linear array of 18 electromagnetic acoustic drivers, positioned on all four walls in a pattern intended to support higher-order mode generation and control. Initial tests will be conducted at frequencies with liners previously tested in the GIT, such that comparisons of the educed impedances can be used to validate the usage of the GFIT.

To simulate aeroacoustic environments for both inlet (upstream propagation) and aft (downstream propagation) liners, and to take advantage of natural boundary layer growth to vary boundary layer profiles, individual components of the 7.3-m (24 ft) test duct are designed to be interchangeable (and reversible). The primary configuration is depicted in figure 4, in which the

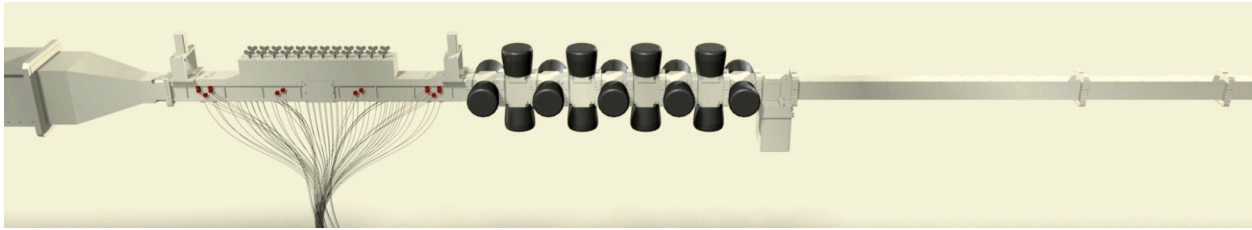

Figure 6. Sketch of NASA Grazing Flow Impedance Tube (GFIT) with inlet configuration

acoustic source section is positioned at the upstream end of the test duct, and is immediately followed by the test window (aft-bypass duct of a commercial aircraft engine nacelle). This arrangement results in minimum boundary layer thickness in the test window region (i.e., uniform mean flow). The acoustic test liner length can vary from 51 to 610 mm, and can be positioned anywhere within the central portion of the test window. In all cases, the surface of the liner forms an upper wall of the duct. Figure 6 depicts an inlet configuration, in which the acoustic liner is upstream of the source section. Additional downstream test window locations (figure 7) allow liner testing for different boundary layer profiles (naturally developing). Boundary layer profile effects on the acoustic liner performance have been a concern for a number of years, and this approach will provide a methodology for comprehensive investigation of these effects without having to introduce “artificial” boundary-layer altering techniques. For the sake of brevity, additional features of this test rig will be presented in future reports.



Figure 7. Sketch of NASA Grazing Flow Impedance Tube (GFIT) with test window moved downstream

3.3 Curved Duct Test Rig (CDTR)

The NASA Langley Curved Duct Test Rig (CDTR, figure 5) is a 152-mm by 381-mm (6”x15”) flow duct used to evaluate acoustic liners in the presence of up to Mach 0.3 mean flow. A high-pressure air supply is used to supply mean flow through the CDTR. Mean flow and the acoustic excitation are combined at the upstream end of the test duct, and travel (left to right in figure 5) past an upstream microphone array, through the liner section, past a downstream microphone array, and through a near-anechoic termination, before being exhausted to the atmosphere. As shown, the CDTR is set up for evaluation of aft-duct liners. However, since the components are interchangeable, inlet liners can also be evaluated by placing the source downstream of the liner section.

A source section comprised of 16 electromagnetic acoustic drivers is located upstream of the lined region. These drivers are positioned in two axial planes (8 drivers per plane), and are arranged such that higher-order modes up to (5,2) can be generated (fifth higher-order mode in the vertical direction, and second higher-order mode in the spanwise direction) at any selected frequency from approximately 0.3 to 2.4 kHz. An array of 31 piezo-ceramic microphones is located between the source section and the liner section. This array of microphones is positioned on all four walls to allow (two-dimensional) modal decomposition. A control system is used to

interface between the source section and the upstream microphone array to generate a selected mode. This system has demonstrated [13] its ability to isolate and control the selected mode (from (0,0) to (5,2)), such that an isolation of at least 10 dB is achieved. Figure 8 provides a sketch of the liner section of the test section. The test liner surfaces form the left and right (vertical) walls of the duct. The flow path through the lined region (from left to right) allows for liners with curvature (“S-shape”), with leading edge-to-trailing edge offsets of zero, 0.5-diameter or 1-diameter (0, 76 or 152 mm). For the case of zero offset, liners with axial lengths of up to 813 mm (32”) can be tested. For cases where curvature is included (as shown in figure 8), the surface length of the liners increases such that the maximum axial extent remains 831 mm (32”).

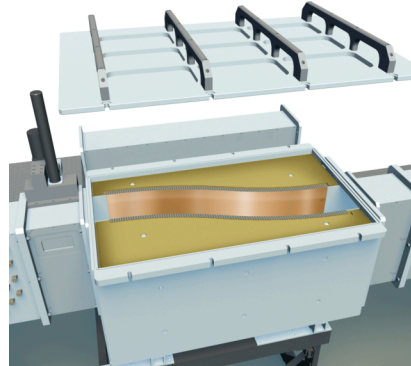

Figure 8. Sketch of NASA Curved Duct Test Rig (CDTR) test window

Another array of 31 piezo-ceramic microphones is positioned downstream of the lined region, such that the transmitted mode amplitudes and phases can be determined. By combining the results from the upstream and downstream microphone arrays, the CDTR can currently be used as an excellent transmission loss (or insertion loss) facility. For a user-selected mode and frequency, the absorption of the lined region (one or both walls containing a liner) can be easily measured. Analog-to-digital devices and a switch matrix are used to acquire the acoustic pressures at each microphone location (for each microphone array) in a manner similar to that described in the discussion above for the GIT.

A number of upgrades are planned for the CDTR. First, high-pressure air supply will be replaced by a fan to supply the mean flow. This fan will be connected to the duct at the downstream end (along with a number of other accompanying modifications) such that it will operate in suction mode. It will provide a significant mass flow increase, and mean flow Mach numbers of up to 0.5 should be achievable. Second, the number of microphones used in the upstream and downstream microphone arrays will be increased from 31 (per array) to 48, such that higher-order modes can be decomposed at frequencies up to approximately 3.4 kHz. Finally, an additional set of microphones will be added in the liner section (likely to be placed in the lower wall), such that the acoustic pressure profile can be measured over the length of the liner(s). These additional data will allow the CDTR to be operated as an impedance eduction facility in a manner similar to that used with the GIT. An aeroacoustic propagation code will iterate the test liner impedance until the measured and predicted acoustic pressure profiles over the liner are matched, and this impedance will be taken to be the test liner impedance.

4 NASA LANGLEY AEROACOUSTIC COMPUTATIONAL METHODS

A thorough description of three duct propagation models used by NASA Langley can be found in the literature (e.g., references [3-11]). Brief descriptions of the underlying models are provided here for completeness. Table 2 provides a comparison of their salient features.

Table 2: Comparison of NASA Langley codes for acoustic liner evaluation

Code	Underlying Equation(s)	Solution Method	Computational Expense	Solution Fidelity
3DFEM	Convected Helmholtz	Finite element	Medium	Medium
LaRC-LEE	Linearized Euler	Finite element	High	High
CDUCT-LaRC	Convected Helmholtz	Parabolic approximation	Low	Low

4.1 3DFEM

The 3DFEM code is based on a 3-D finite element solution of the convected Helmholtz equation using a cubic Hermite finite element and a direct solve strategy. The mean flow is assumed uniform in the duct, and the acoustic pressure field is given by

$$(1 - M_0^2) \frac{\partial^2 p}{\partial z^2} + \frac{\partial^2 p}{\partial x^2} + \frac{\partial^2 p}{\partial y^2} - 2ikM_0 \frac{\partial p}{\partial z} + k^2 p = 0 \quad (1)$$

The wall impedance boundary condition is

$$\vec{\nabla} p \cdot \vec{n} = ik \left[\frac{p}{\xi} \right] + 2M_0 \frac{\partial}{\partial z} \left[\frac{p}{\xi} \right] + \frac{M_0^2}{ik} \frac{\partial^2}{\partial z^2} \left[\frac{p}{\xi} \right] \quad (2)$$

where \vec{n} is the unit normal vector (pointing into the wall). The source boundary condition is $p = p_s$ and the exit impedance boundary condition is given by

$$\frac{\partial p}{\partial z} = \frac{-ikp}{M_0 + \xi_{\text{exit}}} \quad (3)$$

Continuity of the acoustic pressure and its gradient at the liner leading and trailing edges is imposed in the finite element model to ensure the acoustic pressure field remains a continuum.

4.2 LaRC-LEE

A 3-D version of the LaRC-LEE code has been developed, and is currently being evaluated. However, the current version is two-dimensional and employs linear elements and a direct solve strategy. The governing equations for this code are the 2-D linearized Euler equations

$$ikp + M_0 \frac{\partial p}{\partial z} + \rho_0 c_0 \left(\frac{\partial u}{\partial z} + \frac{\partial v}{\partial x} \right) = 0 \quad (4)$$

$$iku + M_0 \frac{\partial u}{\partial z} + \frac{1}{\rho_0 c_0} \frac{\partial p}{\partial z} + \frac{dM_0}{dx} v = 0 \quad (5)$$

$$ikv + M_0 \frac{\partial v}{\partial z} + \frac{1}{\rho_0 c_0} \frac{\partial p}{\partial x} = 0 \quad (6)$$

where the acoustic disturbance is assumed to occur isentropically in an ideal gas, the mean flow is allowed to vary only in the vertical direction, and the total pressure, density and temperature are assumed constant.

The wall impedance boundary condition for a straight duct has been presented by Myers [14]

$$\rho_0 c_0 v = \left(1 + \frac{M_0}{ik} \frac{\partial}{\partial z} \right) \left[\frac{p}{\xi} \right] \quad (7)$$

where ξ represents the surface impedance of the acoustic liner ($\xi = \infty$ along all rigid walls). The acoustic pressure p and the transverse component of acoustic particle velocity v at the source plane vary only in the vertical (x) direction. At the end of the test window, an exit impedance boundary condition (for an assumed plane wave source) is given by

$$\frac{p}{u} = \rho_0 c_0 \xi_{\text{exit}} \quad (8)$$

Finally, the Myers boundary condition assumes the wall impedance is continuous along the liner. The LaRC-LEE model imposes continuity of acoustic pressure and particle velocities at the liner leading and trailing edges to ensure the acoustic pressure and velocity field remains a continuum.

4.3 CDUCT-LaRC

The CDUCT-LaRC code is designed to predict the acoustic propagation within, and far field radiation from, complex 3-D duct geometries. The duct may be hardwall or treated, as CDUCT-LaRC will handle non-uniform acoustic liners (i.e. circumferential or radial segments). The code consists of five distinct modules. The grid generation module performs automatic grid generation for background flow computation and subsequent acoustic calculations. Generation of the background flow is accomplished through the use of the mean flow module. The mean flow is currently taken to be inviscid. This conforms to the assumptions made in the formulation of the approach used in the acoustic propagation calculations. In addition to the functionality provided by these two modules, the capability to import externally generated grids and mean flow solutions exists. The acoustic propagation module is currently based on a parabolic approximation to the convected Helmholtz equation (Equation 1) written in terms of acoustic potential. Based on user supplied source information, calculations result in either the predicted acoustic pressure or potential throughout the duct. These results are then used as input to the fourth module that provides acoustic radiation prediction capability. The calculations are based on the Ffowes Williams-Hawkings (FW-H) equation with a penetrable data surface, and provide predicted radiated acoustic pressure at user-selected observer locations. The fifth module provides post-processing capabilities for the conversion of various output quantities (e.g., acoustic pressure to SPL). The coupled capabilities of the modules comprising CDUCT-LaRC allow efficient prediction of complex directivity patterns from 3-D duct geometries.

The efficiency afforded by the parabolic approximation used within the propagation module of CDUCT-LaRC does come at the cost of reduced fidelity relative to the previously discussed codes (3DFEM and LaRC-LEE). As a result of the parabolic approximation, predictions for modes with propagation angles that deviate significantly from the preferred direction lose accuracy. Fortunately, these modes also tend to be highly attenuated by acoustic liners since they propagate toward the walls of the duct. Therefore, since this code is much less computationally intensive than other approaches, this loss of accuracy is generally acceptable.

5 SUMMARY

NASA Langley is currently upgrading two key experimental capabilities. A 51-mm by 51-mm duct (GIT) is being replaced by a 51-mm by 63-mm duct (GFIT) with utility support for increased flow speeds (to Mach 0.6) to allow liner evaluation for inlet and aft-duct liner configurations in the presence of different boundary layer profiles. A 152-mm by 381-mm duct

(CDTR) currently allows investigation of liner curvature effects for a user-selected mode at mean flow speeds up to Mach 0.3. An upgrade is planned to increase the flow speed to approximately Mach 0.5. NASA currently uses three different aeroacoustic propagation codes to evaluate acoustic liners. Two use finite element methods to solve either the convected Helmholtz equation or the linearized Euler equations, and the third is based on a parabolic approximation to the convected Helmholtz equation. These codes allow the user to balance solution fidelity against computational expense. Together, these experimental and computational tools provide an excellent basis for thorough evaluation of advanced acoustic liners over a range of conditions representative of those observed in aircraft engine nacelles.

6 REFERENCES

- [1] Syed, A.A., Yu, J., Kwan, H.W. and Chien, E., "The steady flow resistance of perforated sheet materials in high speed grazing flows," NASA CR-2002-211749, 2002.
- [2] Armstrong, D.L., Beckemeyer, R.J., and Olsen, R.F., "Impedance measurements of acoustic duct liners with grazing flow," Paper presented at the 87th Meeting of the Acoustical Society of America, New York, NY, 1974.
- [3] Simonich, J.C., Morin, B.L., Narayanan, S. and Patrick, W.P., "Development and qualification of an in-situ grazing flow impedance measurement facility," AIAA-2006-2640, May 2006.
- [4] Watson, W.R., Jones, M.G., Tanner, S.E. and Parrott, T.L., "A finite element propagation model for extracting normal incidence impedance in nonprogressive acoustic wave fields," *Journal of Computational Physics*, Vol. 125, No. 1, pp. 177-186, 1996.
- [5] Watson, W.R., Jones, M.G., Tanner, S.E. and Parrott, T.L., "Validation of a numerical method for extracting liner impedance," *AIAA Journal*, Vol. 34, No. 3, pp. 548-554, 1996.
- [6] Watson, W.R., Jones, M.G. and Parrott, T.L., "Validation of an impedance education method in flow," *AIAA Journal*, Vol. 37, No. 7, pp. 818-824, 1999.
- [7] Jones, M.G., Parrott, T.L., and Watson, W.R., "Comparison of acoustic impedance education techniques for locally-reacting liners," *AIAA Paper 2003-3306*, 2003.
- [8] Jones, M.G., Watson, W.R., Parrott, T.L. and Smith, C.D., "Design and evaluation of modifications to the NASA Langley Flow Impedance Tube," *AIAA 2004-2837*, 2004.
- [9] Nark, D., Watson, W. and Jones, M., "An investigation of two acoustic propagation codes for three-dimensional geometries," *AIAA 2005-3022*, 2005.
- [10] Watson, W.R. and Jones, M.G., "Comparison of a convected Helmholtz and Euler model for impedance education in flow," *AIAA 2006-2643*, 2006.
- [11] Nark, D.M., Watson, W.R. and Jones, M.G., "Further investigation of acoustic propagation codes for three-dimensional geometries," *AIAA 2006-2586*, 2006.
- [12] Bendat, J.S. and Piersol, A.G., "Random Data: Analysis and Measurement Procedures," Wiley-Interscience, 1971.
- [13] Gerhold, C.H., Cabell, R.H. and Brown, M.C., "Development of an experimental rig for investigation of higher order modes in ducts," *AIAA 2006-2637*, 2006.
- [14] Myers, M.K., "On the acoustic boundary condition in the presence of flow," *Journal of Sound and Vibration*, Vol. 71, No. 3, pp. 429-434, 1980.
- [15] Nark, D.M., Farassat, F., Pope, S. and Vatsa, V., "The development of the ducted fan noise propagation and radiation code CDUCT-LaRC," *AIAA 2003-3242*, 2003.