

Next Generation NASA GA Advanced Concept

Andrew S. Hahn
NASA Langley Research Center

ABSTRACT

Not only is the common dream of frequent personal flight travel going unfulfilled, the current generation of General Aviation (GA) is facing tremendous challenges that threaten to relegate the Single Engine Piston (SEP) aircraft market to a footnote in the history of U.S. aviation. A case is made that this crisis stems from a generally low utility coupled to a high cost that makes the SEP aircraft of relatively low transportation value and beyond the means of many. The roots of this low value are examined in a broad sense, and a Next Generation NASA Advanced GA Concept is presented that attacks those elements addressable by synergistic aircraft design.

INTRODUCTION

In order to understand where the SEP GA aircraft fits in to the transportation system and its future potential, one needs to examine the fundamental demand for transportation and the elements that constrain the traveler's choices. Also, the concept of transportation value is examined in narrow performance terms and expanded to include broader considerations. Finally, those value considerations that are addressable through synergistic aircraft design are identified and approached with a specific demonstrator concept vehicle.

TRANSPORTATION DEMAND

The ability to travel is one of the most basic human needs. The more travel made possible, the greater the socioeconomic opportunities available. Schafer reports that the ability of an individual to travel is constrained primarily by two budgets, time and money, and that the aggregate behavior of people can be largely explained by the average budgets of groups [1]. Although not completely separable because of land use specifics, it appears that demand for travel is mostly constrained by the time budget and that travel mode choice is mostly constrained by the money budget.

TIME BUDGET - Figure 1 indicates that the average time budget available for daily travel appears to be relatively stable across income levels and cultures [2]. Although there is obviously large variation between

individuals, this aggregate result implies that there is a fundamental limit on how much time most people are willing to spend in daily travel, and is approximately 1.25 hours.

TRAVEL TIME BUDGET: GLOBAL DATA

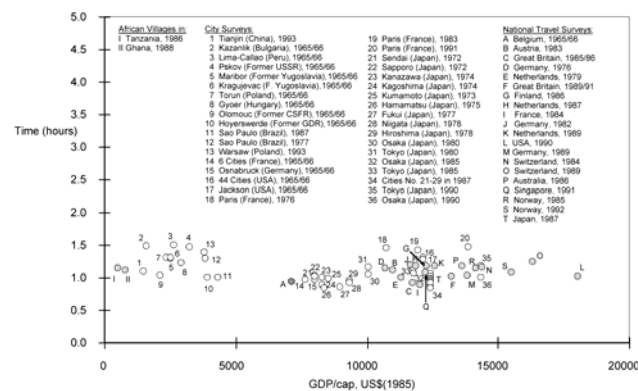

Source: Schafer and Victor (2000)

Figure 1 – Daily Travel Time Budget

This appears to be the result of most people leading similar lives, with the bulk of the day spent sleeping and working, leaving about the same amount of time for the rest of life. By measuring the travel budget in time, instead of distance, the characteristics of the main travel mode are removed, allowing behavioral predictions when a new mode becomes available and affordable.

TRIP FREQUENCY - By extending the idea of a daily time budget, it is possible to get an aggregate model of trip frequency as a function of time. Three sources of data were merged to get a distribution of American trip miles as a function of distance in 1995 [3,4,5]. Figure 2 shows this distribution by mode and Figure 3 shows the cumulative distribution by mode. What is striking is how completely dominant automobile travel is over all other modes, even out to the 1000-2000 mile trips.

transportation would be worth paying for up to that limit. For example, walking is free, yet most people drive automobiles, which are far more costly. That's because the economic opportunity afforded by the much faster automobile is worth paying for. Similarly, some people may be able to take advantage of an aircraft despite a higher cost because of the economic opportunity it brings. Whether someone decides to switch to the aircraft mode for any significant amount of travel will depend on the individual's and the aircraft's economic specifics, but the idea is to substantially reduce the cost of the aircraft to make it attractive to many more people.

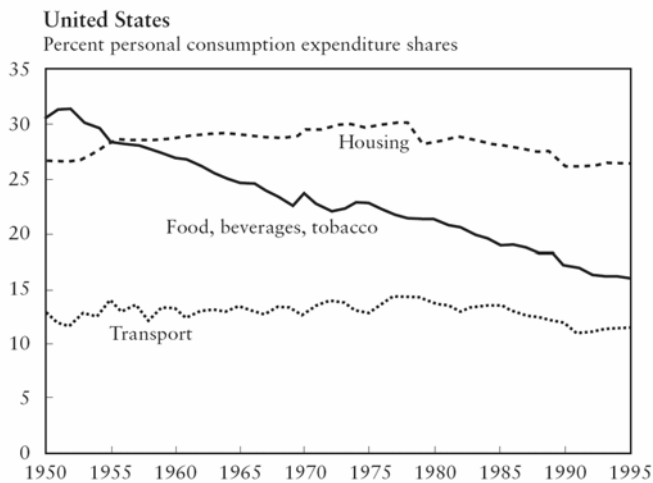

Figure 5 – US Money Budget over Time

Conversely, if people live in a region that varies significantly from this budget, then a faster mode of transportation could be attractive because it enables a rebalancing of the budget. For example, the San Francisco Bay Area has exceptionally high housing prices, which force most people to spend much more on housing than Figure 5 suggests. There is a steep negative housing price gradient as distance increases from the SF Bay Area, which gives strong economic incentive to live farther out. In this case, the value of the housing, transport, and travel time in total is what is important and a mode that is much faster could be worth paying for as well. This is already true for the riders of the Altamont Commuter Express train in the SF Bay Area and an aircraft with the right balance of features could also be attractive in that, or similar, areas.

As a point of cost reference, the American Automobile Association estimates the current average cost of a mid-size sedan at about 25 cents/km (40 cents/mile) [6] and the U. S. Federal government reimbursement rate for Personally Operated Vehicles (POV) is about 28 cents/km (44.5 cents/mile). This compares to the U. S. Federal government reimbursement rate for privately owned aircraft of about 66 cents/km (107 cents/mile) and the average airline cost of about 9 cents/km (14

cents/mile) [7]. To some extent, this is an unfair comparison, because the airline benefits from high load factors and long distances. A model devised by Earl Wingrove in 2001 suggests that the airline cost is really made up of a fixed cost and a variable cost [8]. Adjusting for inflation, the 2006 fixed portion is \$66.81, the business variable cost is 8 cents/km (13 cents/mile), and the personal variable cost is 4 cents/km (7 cents/mile). Using the personal variable cost at the average 1391 km (864 mile) flight distance, the predicted cost is 9 cents/km (15 cents/mile), which compares quite favorably to the previously stated 9 cents/km (14 cents/mile). This model now allows a much more fair comparison between the airline cost and other modes by removing the trip distance bias. The airline still has a legitimate cost advantage because their load factors are uniformly high.

The fact that the airline has a lower cost/km implies that high-speed modes that tend toward longer trips will actually have to have a lower cost per km to be viable, and compromises to make this possible, such as pooling or smaller aircraft, are likely to be accepted by the traveler. Still, for the SEP aircraft to be widely attractive, it will have to attain a similar or even better cost than the automobile, which requires at least a 60% reduction from present.

TRANSPORTATION VALUE

Whether a given mode of travel is chosen over another is the result of a complex value judgment. It is not simply a matter of cost, but of utility to cost ratio in a broad sense that matters. Despite a bicycle being far less costly than an automobile, it is the automobile that completely dominates travel mode choice. Unfortunately, it is very difficult to devise an accurate model given the multitude of considerations that a customer must weigh and the subjective nature of many of those considerations. Still, there is some value in trying to determine basic measures where possible and identifying those subjective characteristics that matter most.

FIGURE OF MERIT - In 1987 Emmet Kraus devised a Figure of merit (F), based on readily available specifications, that could at least roughly stand in for the perceived utility of an aircraft [9]. F does this by consolidating typical efficiency and productivity measures (payload, range, cruise speed, cabin volume, and fuel specific range) into a single value that also captured the diminishing returns of increased performance. Kraus then attempted to correlate with price and the number of aircraft sold. Later, Kraus updated F to include the significant new aircraft models that were just appearing in 2001 [10]. These updated calculations for the year 2002 are shown in Figure 6.

If one defines value as the ratio of utility to cost, and utility can be measured by F, then the data in Figure 6

may be combined with sales figures [11] to produce Figure 7.

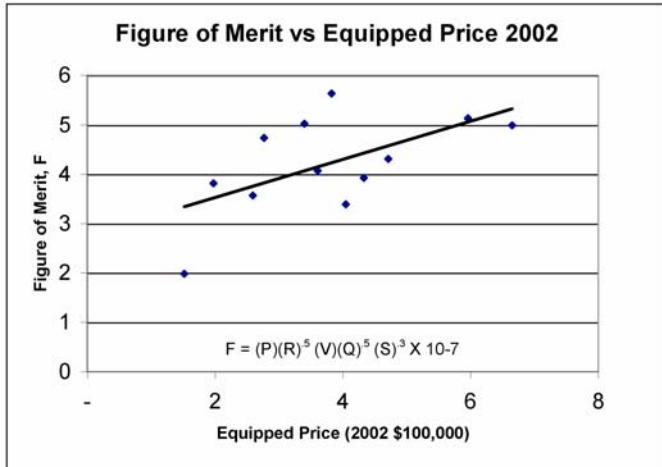

Figure 6 – Figure of Merit Correlation With Price

Figure 7 shows that there is a general trend for aircraft with better value, to have greater sales, but the correlation is weak, indicating that there are probably other important characteristics that go into the customers' evaluation of value.

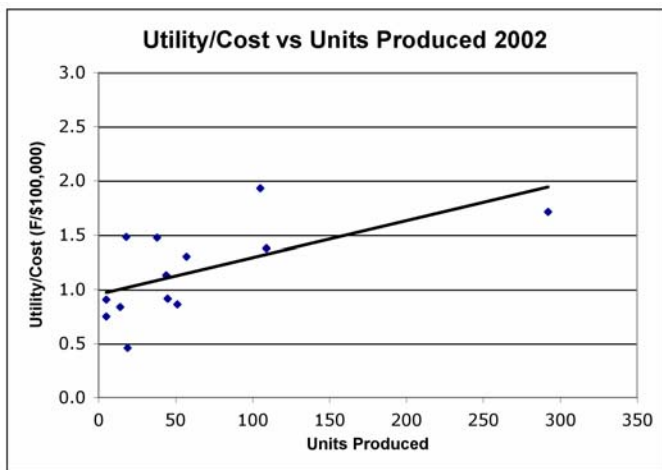

Figure 7 – Objective Value Correlation with Units Produced

SUBJECTIVE CHARACTERISTICS - Kraus recognized that there was much more to consider than the objective characteristics measured by F [9]. To capture the subjective considerations, he also suggested some threshold characteristics that needed improvement to increase sales. It is important to recognize that he was not just considering minor improvements to capture a bigger piece of a fixed market, but was trying to suggest

major improvements that would appeal to a broader market. These characteristics are:

- Substantial improvements in reliability, maintainability, and servicing
- Substantial reduction in noise and vibration
- Improved ride quality
- Integrated pictorial instrument and navigation displays
- Digital data linkup and displays
- On-board collision avoidance system
- Simplified power management

It is interesting to note that modern avionics and controls are addressing the last four of these characteristics, but the first three have shown little improvement.

FUTURE MARKET CHALLENGES - While this earlier work was a step in the right direction, it fell short of fundamentally breaking the stagnation that the SEP market was experiencing. The problem seemed to be that the SEP aircraft had a very limited value as a transportation mode. The market had been experiencing poor sales for a long time, and was behaving like a product at the end of its life cycle. Figure 8 shows that the cumulative piston engine aircraft sales was following a classic "S" curve over the 1950 to 1995 time frame and appeared to be in its final stages [12]. The introduction of significant new designs and the glass cockpit revolution appears to have started a new product life cycle, but it is anemic by comparison.

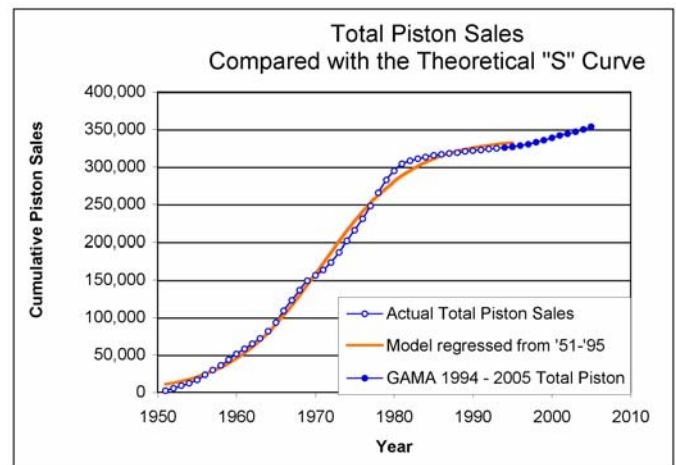

Figure 8 – Piston Engine Aircraft Life Cycle "S" Curve

The trend data for the pilot base is also looking unfavorable for the future. In 2005, private pilots numbered about 229,000, which is down 29% from 1984 [11]. Similarly, commercial pilots number about 121,000, which is down 23%, and most alarmingly, student pilots number about 87,000, which is down 42%. The only positive trend is that Air Transport Pilots (ATP) number

about 142,000, which is up 79%. Still, there is a total pilot net loss of 18%, which is shown in Figure 9.

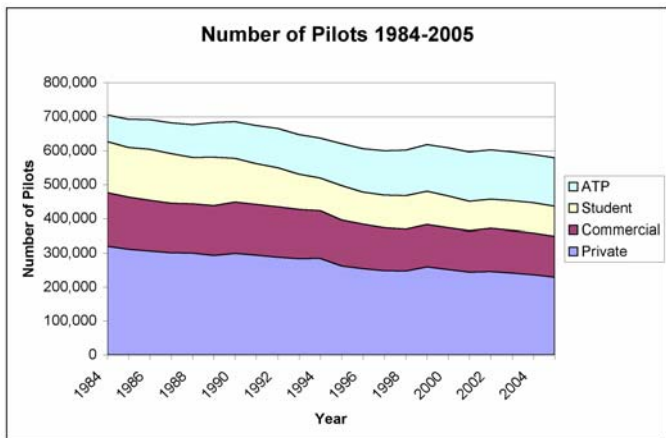

Figure 9 – Number of Pilots 1984-2005

Another troubling trend is that the average age of pilots is increasing, from 41.3 years in 1993 to 45.1 in 2004 [11]. Clearly, when the baby boom generation can no longer fly, the industry is bound to face a steep decline. Moreover, catering to pilots is extremely unlikely to produce much more than a replacement level of sales. What is needed is a radical rethinking of the SEP aircraft to make it much more useful and much less costly so that it is attractive to a much larger base of customers.

PERSONAL AIR VEHICLE TECHNOLOGIES

The Personal Air Vehicle (PAV) concept was a broad approach to addressing the lack of travel value of a self-operated SEP aircraft and the personal budget constraints highlighted by Schafer. While there are many barriers to wide adoption, the top three targeted for attention were Ease-of-Use (EoU), pollution (noise and emissions), and cost. The approaches studied went far beyond the airframe, and will be only touched on to give a sense of the context in which the vehicle fits.



Figure 10 – 1943 Cessna Advertisement

OVERALL PAV SECTOR CONCEPT – The desire by ordinary people, to travel by aircraft to distant places easily and safely has been around for at least 60 years. Figure 10 is a Cessna advertisement from 1943 that ran in Aviation Week magazine and shows two women flying much as they would drive to some destination [13]. Clearly, this vision has not come to fruition over the intervening time. The whole PAV concept was predicated on making the SEP aircraft a viable transportation mode choice for many more travelers than it currently is. This meant identifying the barriers that currently prevent wide adoption, prioritizing them, and defining a technology investment plan to overcome as many as would fit within the proposed time and budget. Using the concept of transportation value as the ratio of utility to cost, both utility and cost were decomposed to aid in finding the key barriers to widespread adoption.

Utility - Utility was summed up in the slogan, “Faster, Farther, Anytime, Anywhere, Safely.” Decomposing each characteristic helped crystallize the NASA PAV sector’s requirements.

Faster is the whole point behind the flight travel mode. This drove one metric definition to being a DtD block speed that was several times greater than the mode of choice, namely automobiles. The important thing to keep in mind is that the metric is DtD, not cruise speed. Reducing inter-modal delay is actually more effective as trip distances shorten, indicating that strategies addressing delay are more attractive than the traditional approach of increasing cruise speed.

Farther is partly a consequence of Faster combined with Schafer’s time budget concept, but is also in recognition of the automobile’s inherent advantage in inter-modal delay. Below a certain distance, the automobile will simply dominate, but there is still a lot of travel in the medium to long-range trips that the PAV could service better, and the availability of the PAV could eventually

enable a shift in daily travel to distances that would be unacceptable for the automobile.

Any Time is an expression of the kind of freedom that people have grown accustomed to with their automobiles. If the PAV doesn't at least approach the ability for travelers to make trips when they want, with the kind of confidence and work load that they currently enjoy with the automobile, then the loss in utility would prevent wide adoption. The PAV must be easy to fly in near-all-weather operations.

Any Where is also an expression of the kind of freedom that people have grown accustomed to with their automobiles. To be useful as transportation, the PAV must get the traveler to where they want to be. Strategies that shorten or even eliminate the ground legs at the origination or destination have a profound effect on this aspect of utility.

Safely, both real and perceived, is an absolutely critical threshold that must be maintained if widespread adoption is ever to be achieved. This is a very high bar to clear because it is in combination with the need to have near-all-weather capability and with much lower work load.

Cost – Costs really are much broader than simply the typical fixed and variable costs associated with operating a vehicle. Also, the industry has tended to focus on the pilot centric costs, probably because pilots are their customers. However, if there are ever going to be many more SEP aircraft in use, then the costs to others in the community need to be given strong consideration.

There are essentially four pilot centric costs. The first cost, and most obvious, is money and most of this cost is from the traditional fixed and variable costs of vehicle ownership. However, there are significant money costs associated with attaining and maintaining their license, which should not be overlooked. The second, and increasingly dearer cost, is time. Significant time commitment is required to both attain a license and maintain proficiency, particularly with the instrument rating necessary for near-all-weather operation. The third cost is effort. Preparing to be a pilot and maintaining the knowledge gained requires much more deliberate study than being a driver does. This aspect alone is intimidating and makes many people feel that being a pilot is just beyond them. The fourth cost is a lack of comfort. SEP aircraft typically have internal environments that border on abusive. The interior noise is so high that wearing active noise canceling headphones is considered an excellent option. The vibration is unnerving to those unused to it and unnecessarily fatiguing on long flights. The heating and cooling systems are usually primitive, creating wide temperature variations within the cabin. The last cost is that the ride quality in turbulence can be nauseating or even dangerous. In short, much more needs to be done in these pilot centric cost areas.

The major community costs are under the heading of pollution. There are three forms that dominate. The first form, and the most contentious, is noise. Noise has been an ever-present problem with SEP aircraft because the greatest source of noise is the propeller. Pilots have traditionally put up with the noise as an unavoidable consequence of their activity, usually taking steps to protect themselves while radiating in all directions. It is possible to make a quiet propulsor, but it is inevitably heavier, costlier, and less efficient, so the pilot has little desire to accept the penalties. When aircraft activity is infrequent or far away, it is tolerable to the community, but this also constrains the aircraft to such an extent that it can't become a serious travel mode choice. Hostility to aircraft operations is such that when a community was given an airport for free, they chose instead to convert it to shops and a golf course [14]. In order to raise the utility of the PAV, noise from all sources must be radically reduced so that the frequency and proximity of operations can rise. The second form is tailpipe emissions. Currently, SEP aircraft emissions are unregulated and they would fall into the category of gross polluters if they were automobiles. Aircraft are also the last users of leaded gasoline. The only reason this situation is allowed is because there is so little activity that these individually gross polluters don't add up to as significant of a problem as barbecue grills, lawn mowers, and weed whackers, which California is seeking to regulate. The third form is disposal pollution. Many of the older materials are not only recyclable, but because of their scrap value, actually are recycled. Modern materials, like composites, are generally not recyclable, but even if they are technically recyclable, they generally are not because of low scrap value. Once again, this is tolerable at the very low rates of production seen today, but if the aircraft is ever to have a more prominent future, then the design must adopt a cradle-to-cradle lifecycle philosophy.

Critical Barriers – Clearly, there are many barriers to wide spread adoption of SEP aircraft as a travel mode of choice. NASA's PAV effort could not possibly address them all at once, so EoU, pollution, and cost, while maintaining safety were chosen as the top priorities. A desired capability set that reflected these priorities was created to guide the investment in technological approaches. This capability set was given the acronym EQuIPT (Easy-to-use, Quiet, Personal Transportation) and is defined as:

- DtD block speed of 161 kph (100 mph), which is approximately three times the automobile average.
- Automotive-like EoU, comfort, and trip dependability.
- Acquisition cost of \$88,200 (Y2006).
- Noise levels at 152 m (500 ft.) distance equivalent to a motorcycle.
- Airfield length of less than 762 m (2500 ft.).
- Fuel economy of at least 6.4 km/l (13 nmpg).

- Safety of no more than 2 accidents per 161,000 km (2 accidents per 100,000 miles)
- Emissions for HC/NOx/Lead of 0.03/0.06/0 g/km (0.05/0.1/0 g/mile)

All goals and technology approaches considered by the PAV sector had direct lineage back to these EQuIPT capabilities.

ADVANCED CONCEPT VEHICLE – In order to evaluate the various technology approaches that the PAV sector considered, a conceptual aircraft design was created to act as a technology investment portfolio tool. Because this design was intended to demonstrate the impact of new technologies, the design choices tended toward preferring stretch goals in the priority areas of EoU, pollution, and cost, usually at the expense of performance. While this design is clearly not intended to be a product, it was recognized that any technologies worth consideration would have to increase transportation value and that the overall aircraft had to be reasonably close to a practical product to have significant demonstration impact. For the same reason, any design or technology choices would also have to be plausibly certifiable by the Federal Aviation Administration (FAA). Once the design choices had been made, most of the following effort was spent in validating key assumptions and reducing uncertainties.

Concept Description – Just as no one model, or even class, of automobile can satisfy the mobility demand of all drivers, no one PAV design can satisfy the mobility demand of all travelers. The popularity of the four seat sedan with drivers and of the four to six seat SEP aircraft with pilots indicated that the most relevant demonstration would result from a PAV in this basic size class. The specific demonstrator design that was adopted is shown in Figures 11 and 12. The configuration was given the descriptive generic name TailFan, and this particular concept is referred to as the Civetta, which translates to “little owl” from Italian.



Figure 11 – EQuIPT Civetta PAV Demonstrator Concept



Figure 12 – EQuIPT Civetta PAV Demonstrator Concept Four View

The Civetta is still in the early stages of design, with many significant uncertainties, which makes a detailed and accurate performance assessment difficult; however, the current estimate of the Civetta’s specifications are as follows:

- Length: 8.08 m (26.5 ft)
- Height: 3.29 m (10.8 ft)
- Wing Span: 11.89 m (39.0 ft)
- Wing Area: 15.10 m² (162.5 ft²)
- Cabin Length: 2.53 m (8.3 ft)
- Cabin Width: 1.40 m (4.6 ft)
- Cabin Height: 1.22 m (4.0 ft)
- Cabin Volume: 3.91 m³ (138.0 ft³)
- Gross Weight: 1633 kg(3600 lb)
- Empty Weight: 1111 kg(2450 lb)
- Useful Load: 522 kg (1150 lb)
- Fuel Capacity: 322 l (85 gal)
- Engine: Chevrolet LS-1 V8
- Power: 224 kW (300 hp)
- Cruise Speed: 302 km/hr (163 kts)
- Cruise efficiency: 5.4 km/l (11.1 nm/gal)
- Cruise Fuel Flow: 55.3 l/hr (14.6 gal/hr)
- Landing Speed: 96 km/hr (52 kts)
- Landing Gear: Fixed Tricycle

As alluded to earlier, these specifications are good, but not class leading. This is a direct result of trading a little performance and efficiency for dramatically better outcomes in Ease-of Use, Pollution, and Cost.

Ease-of-Use – EoU was ranked the most important of all of the barriers preventing widespread adoption of SEP aircraft for personal transportation. This is because it profoundly affects the transportation value of the SEP aircraft through both utility and cost. While there are EoU aspects to the TailFan configuration, by far the greatest impact would come from the Naturalistic Flight Deck (NFD) and Haptic (H-mode) control interface work being done by Frank Flemisch and Ken Goodrich [15]. Since

this exciting technology is mostly avionics based, it is applicable to other aircraft configurations and so will only be briefly described here.

Often, visionaries see a need, but they lack the means to bring a solution to fruition. What generally happens is that real needs persist until such a time as the critical enabling technology becomes available and a new market sector takes off. The problem is not that the visionary was foolish, but that they were ahead of their time. The greatest change in technology generally creates the greatest opportunity for realization of unfulfilled vision. Because of the incredible improvements seen in the last 20 years in the computer, software, and communications fields, this is the area to leverage for change. Already, these fields are enabling the military's infant Uninhabited Air Vehicles (UAVs) and distributed, Network Centric Battlefield command and control architecture. While these systems are expensive and unreliable, the development time and resources devoted by the military will improve them over time and the lessons learned and the technologies created will have a direct impact on the make up of the civilian airspace.

Flemisch and Goodrich recognized this and set out to apply these new technologies to the problem of enabling near-all-weather, single pilot operation with greatly reduced training, in a self separated airspace while maintaining high safety. They recognized that, for the foreseeable future, fully autonomous flight would not be robust enough for carrying people. While it is not good to crash a UAV in an unpopulated area, it is unacceptable to crash an autonomous vehicle with travelers on board in a densely populated area. Their idea is to take two unreliable systems, namely the pilot and the autonomous vehicle, and create a human factors aware interface that makes the partnership much more robust than the individual elements would be separately.

The NFD is a suite of avionics developed with human factors input that allows much easier assimilation of the information already presented in cockpits, which reduces training time and effort for the pilot. The NFD enables a proficient pilot to be able to fly alone in near-all-weather with confidence and relative ease. The H-mode is a full authority flight control system that, theoretically, is capable of fully autonomous flight. If the pilot stays fully engaged and makes no mistakes, then he will never know that the H-mode is there; however, the H-mode is there as a backup for when work load exceeds the pilot's capabilities or when he makes a mistake.

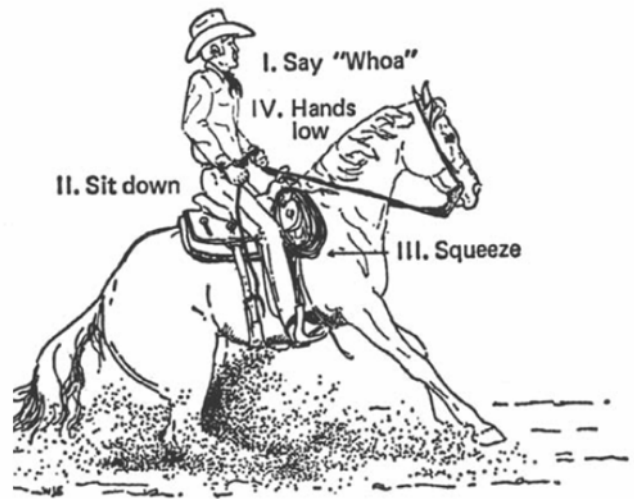

Stopping (Western Equestrian, Miller, 1975)

Figure 13- Rider and Horse Analogy for Pilot and H-mode

The pilot's relationship to the H-mode has been compared with a rider's relationship to the horse (Figure 13). Pilot and machine communicate intent through tactile feel and each does its part. The pilot does not directly manipulate control surfaces, just as the rider does not place each individual hoof. The pilot guides the PAV with the control stick and the H-mode negotiates turbulent air as best it can, just as a rider guides through the reins and the horse negotiates rough terrain. If the pilot tries to perform a dangerous maneuver, the H-mode will attempt to take corrective action, just as the horse will balk when the rider instructs it to do something that might harm it. If the pilot is inattentive, the H-mode will try to re-establish involvement and, failing that, will assume that the pilot is incapacitated and divert to the nearest airfield for help, just as a horse would bring its rider to the barn. The key difference between the H-mode and the horse is that the pilot is always in command and can always override the H-mode simply by applying more force, whereas any rider will tell you that sometimes the horse has a mind of its own. It is the maintenance of the pilot in command principle that allows the benefits of the pilot-H-mode partnership without the liabilities of autonomy unreliability.

Another potential benefit is that the immediate feedback by the H-mode when the pilot makes a mistake should greatly speed the pilot's acquiring proficiency. It is much like having a robotic instructor pilot along at all times.

The utility improvements that would come from confident near-all-weather operation, the cost reductions in both time and money for training and maintaining proficiency, and the safety improvements, both real and perceived, make the NFD and H-mode avionics systems incredibly attractive EoU enablers for the PAV. Of course, the

development cost of such advanced systems is going to be high and the technical risks involved are substantial, which is why NASA was funding the research internally. By accepting the greater part of the development risk and cost, it was hoped that NASA could get the technology to the point where private industry could commit to it and finish the development necessary for providing a product. Even so, if the number of production units stays historically low, then the unit cost would be prohibitive. The optimistic hope is that by providing a much greater transportation value, coupled with a much more appealing and lower cost vehicle, that the PAV would appeal to very many more travelers, making the number of units produced much greater than the industry has come to expect, thereby reducing the unit costs to an acceptable level.

While not as spectacular as the NFD and H-mode, there are several EoU features of interest specific to the TailFan configuration.

First, all useful load is added in front of the most aft Center of Gravity (CG) location allowed. Therefore, it would not be possible to load the TailFan in a dangerous, unstable condition. Also, as the TailFan is loaded, the CG moves forward, making it more stable. Pitch response will be slower, making the aircraft feel heavier as it becomes heavier. This subtle queue to the pilot is in the right direction and opposite to most SEP aircraft. In extreme conditions of overloading, the TailFan is more likely to run out of pitch control power, making it reluctant to rotate for takeoff. While it is impossible to guarantee that it won't rotate when overloaded, this natural tendency is welcome.

Second, the propulsor at the back end of the fuselage is stabilizing with power on, which is most of the time. Most SEP aircraft have their propellers in front, which is destabilizing. Also, there is an opportunity to provide reverse pitch on the fan, which would allow aggressive braking regardless of runway conditions and the aft mounted propulsor is stabilizing in this condition as well.

Third, the engine operation is essentially carefree because of the adoption of the mass produced automotive engine. The standard throttle by wire and full authority Electronic Engine Control Module (EECM) performs all engine management automatically, so manual management of priming and mixture are eliminated. Under conditions of detonation, the EECM automatically retards ignition timing to protect the engine. The sequential port fuel injection eliminates the possibility of intake icing, so manual application of carburetor heat is unnecessary. The liquid-cooled engine eliminates the possibility of shock cooling and the thermostatically controlled cooling fan prevents overheating. Even in the event of total loss of cooling, the engine will revert to a limp home mode where alternating cycles of combustion and fresh air are run in each cylinder, reducing power but essentially internally air cooling the engine so that it can continue running.

Fourth, the propulsor management is automatic, much like the automatic transmission in a car. Both engine and propulsor are controlled through a single thrust lever that has full authority between full forward and full reverse thrust with a simple linear motion, and with the H-mode providing safety backup.

Last, entry and exit are easy because the large doors are located completely in front of the wing. This means that travelers do not have to climb up onto a low wing or stoop to get in under a high wing and the door sill is at floor level, unlike aircraft with sliding canopies. The sill is 0.8 m (2.6 ft), requiring a step up, but it is only 4 inches higher than the Ford F150 XLT.

Pollution – Pollution was ranked as the second most important of all of the barriers preventing widespread adoption of SEP aircraft for personal transportation. This is because communities can have profound impact on the operations, and therefore utility, of aircraft. Time and again, communities have sought to reduce objectionable aircraft operations. While it can be argued that there is currently an equilibrium, it is only because of the small number of aircraft that operate infrequently, often from remote airports. If the PAV is to become a significant contributor to mobility, then the number of operations has to increase by several orders of magnitude. This means that both the frequency and proximity of flights has to increase dramatically, and this would prove intolerable to the communities that the PAV seeks to serve.

Noise - By far, the most objectionable kind of aircraft pollution to the community is noise. This is because its effects are noticed immediately, intensely disliked, and affect large areas due to radiation in all directions. Noise is also objectionable to many potential PAV pilots who are used to the comfort provided by the automobile and find the cockpit environment unpleasant. In order to appeal to a much wider market, the interior noise must be reduced as well.

In order to reduce noise, one must first identify its sources. Contrary to popular belief, the propeller, not the engine, is the greatest source of noise, both internal and external. There have been many attempts to reduce propeller noise, but they all result in the same solution. The quiet propeller is heavier, costlier and so large that it is hard to integrate into a practical configuration (Figure 14).



Figure 14 – Quiet Propeller Configurations (NACA, Lockheed, NASA)

In the 1970s, NASA sponsored Hamilton-Standard to perform a series of studies and tests aimed at producing a quiet propeller. They found the same solution as others before, that the quiet propeller had to have a large diameter, multiple blades, wider blades, and low tip speed [16]. Because the propeller required a gearbox to match RPMs with the engine, and the diameter made the conventional tractor mounting unattractive, Worobel and Mayo investigated the option of using a ducted fan propulsor instead. Figure 15 compares the baseline propeller to the two other propulsor options.

The goal was to achieve an unprecedented 30 PNdB decrease from the baseline propeller, which was representative of a typical, high performance SEP aircraft. The key things to note are; both quiet propulsors are heavier and costlier, and neither can be retrofitted to existing designs. Having a quiet propulsor, by necessity, requires a new configuration.

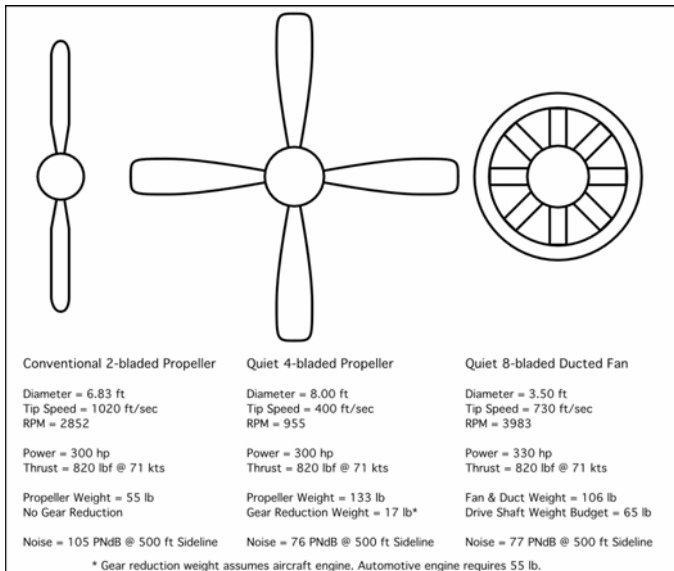

Figure 15 – Propeller, Quiet Propeller, Quiet Ducted Fan Comparison

When choosing between the quiet propulsors, the propeller is significantly heavier than the ducted fan. Internal estimates also indicate that the gearbox weight claimed by Worobel and Mayo is quite low at 7.7 kg (17 lb). This may be accurate for an aircraft engine, but we wanted to substitute an automotive engine for cost reasons, and the higher required gear ratio increased the gearbox weight substantially. We estimate that the actual gearbox weight is about 34 kg (75 lb), making the propeller almost twice as heavy as the ducted fan. When one considers the additional cost, complexity and reliability issues with having a gearbox, the propeller looked much less attractive than the ducted fan. The two really serious drawbacks with the ducted fan are that it is at least 10% less efficient than the propeller and is much harder to design to be efficient over a broad speed range.

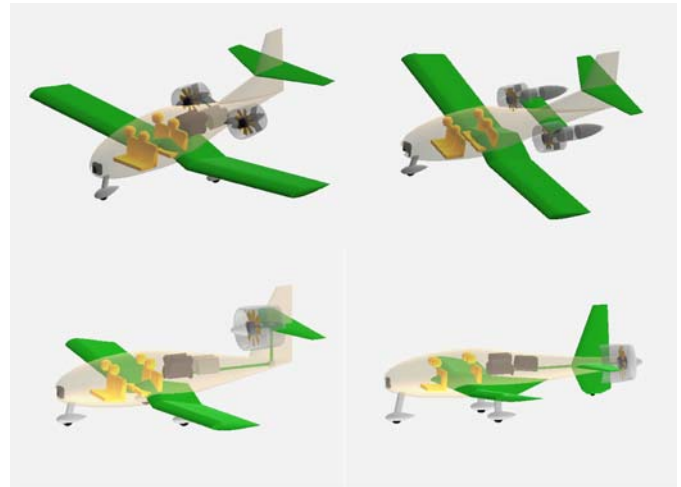

Figure 16 – Ducted Propulsor Integration Configurations

Having decided on the Quiet ducted Fan (Q-fan), the next step was integration into a configuration. The conventional tractor mount was unattractive because the diameter of the Q-fan was less than that of the fuselage and the loss of efficiency would be unacceptable. Several integration configurations were qualitatively assessed (Figure 16) and while all had strengths and weaknesses, the TailFan configuration emerged as the most attractive.

The main problem with the multiple Q-fan configurations is that they nearly double the cost and weight, despite having advantages in integration and allowing tractor operation, which may have noise advantages. Also if one engine is used, then drive shafts and direction changing gearboxes are required, or if two engines are used, then cost and complexity increases as well as creating balance problems. The fin mounted Q-fan is a more attractive option, but still requires direction changing gearboxes and the high mounting location creates a pitch change moment with changes in thrust.

Because the TailFan configuration is single engine and direct drive, it has really only two serious drawbacks.

The first drawback is a long drive shaft to separate the engine and Q-fan, maintaining the CG where it needs to be. Historically, long drive shafts in aircraft have had mixed results. While having a long driveshaft should not be taken lightly, we are confident that being aware of the problem and budgeting adequate design and development resources will yield a light-weight, low-cost, reliable, and durable component. Examples of success include the Bell P-39 Airacobra, the Dornier 335 Pfeil, the Taylor Aerocar, and the Leshar Teal. Examples of the difficulties involved include the Cirrus Design VK-30 and the Bede BD-5.

The second drawback is that the stators that position the duct are in front of the fan. This is of concern because the wakes coming off of the stators cause sudden changes in the angle of attack of the fan blades as they pass through, potentially increasing noise. While this is true, it is unclear that it is any worse than if the fan were in front. In this case turbulent wakes shed by the fan suddenly change the angle of attack of the stators, also increasing noise.

This issue of having the stators in front is one of the largest uncertainties in this configuration. Still, Worobel and Mayo stated clearly, “ While the Q-fan performance, noise, weight and cost generalizations presented herein have been made on the basis of a tractor configuration, it is felt that with proper design of the duct in relation to the forebody, the performance and noise of the pusher configuration will be essentially the same as that of the tractor configuration” [19]. To date, the only test of a pusher Q-fan on an airframe was done at NASA Langley and was inconclusive [20]. A short chord Q-fan was retrofitted to a Cessna 337, which was far from desirable. The inflow was severely distorted because of the poor installation, and the Q-fan design was compromised more toward better performance than noise (Figure 19). Still, the increase in noise over that predicted was only 6 dB, which we feel is an absolute worst case.

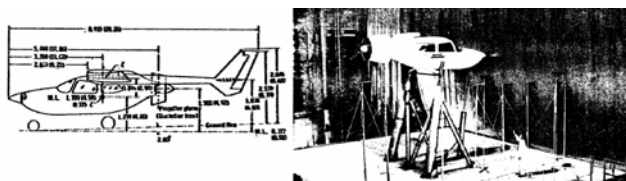

Figure 19 – Cessna 337 Q-fan Test Article

In the event that ingested wakes do increase the noise, there are also several mitigation options available to investigate. The short list is:

- Boundary layer suction on stators
- Blowing to fill in the wake, either continuous or timed synthetic jet
- Swept fan blades
- Non-radially aligned stators
- Serrated trailing edges on stators to promote faster mixing
- Varying the size, number, and asymmetry of stators

Unfortunately, we have very little ability to evaluate the impact of design choices on noise. Our main sources of information are the original Hamilton-Standard contractor reports. While they form a good basis for evaluation, we have access to only two other methods that address Q-fan noise estimation. The first is a ducted version of the Massachusetts Institute of Technology (MIT) computer code named Xrotor. Unfortunately, Xrotor measures noise in a different way, namely peak dBA, and only does the isolated rotor so it misses critical effects of shielding, absorption, and stator wakes. Still, it is useful in making relative comparisons during fan design. The second is a NASA Glenn Research Center computer code named ADPAC. While ADPAC is capable of doing very sophisticated analysis, the effort required in doing the best analysis is substantial. While we have not used ADPAC yet for noise assessment, it has been used to guide the duct design for performance. Figures 20, 21, and 22 are carpet plots based on the Hamilton-Standard data that show the basic tradeoff of noise versus efficiency for the baseline design of 1.1 m (3.5 ft) diameter, 224 kW (300 HP), and a fan tip speed of 219 m/sec (720 ft/sec) [21].

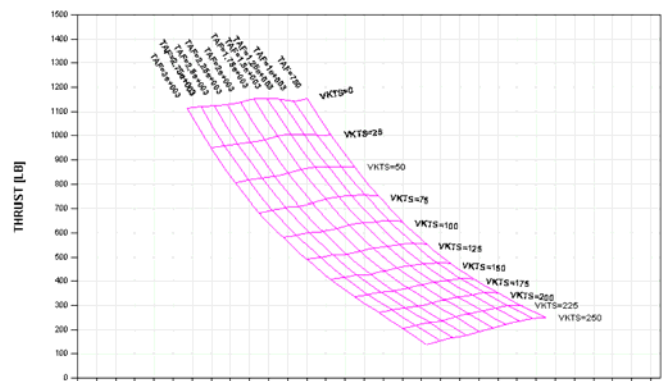

Figure 20 – Thrust vs Total Activity Factor (TAF) vs Speed

Figure 20 shows that there is little variation of static thrust with Total Activity Factor (TAF), although there is significant loss of thrust at 463 km/hr (250 kts) with higher TAF being worse.

Figure 21 shows that peak efficiency as well as high-speed efficiency is a strong function of TAF, again with

higher TAF being worse. The Civetta's economy cruise speed of 302 km/hr (163 kts) and high cruise speed of 320 km/hr (173 kts) bracket the peak.

Figure 22 shows that there is a steep decline in noise with increasing TAF from 750 to 1750, but diminished returns beyond 1750, and essentially no variation with speed. In keeping with our philosophy of trading some performance for major gains in PAV priorities, a baseline TAF of 1750 was chosen, yielding the noise value of 77 PNdB which limited the peak propulsive efficiency to about 0.70. This is in contrast to the peak propulsive efficiency available for the Q-fan at a TAF of 750 of 0.74, but yielding a much higher noise of 95 PNdB and approximately the 0.85 propulsive efficiency of a conventional propeller at a noise level of 105 PNdB.

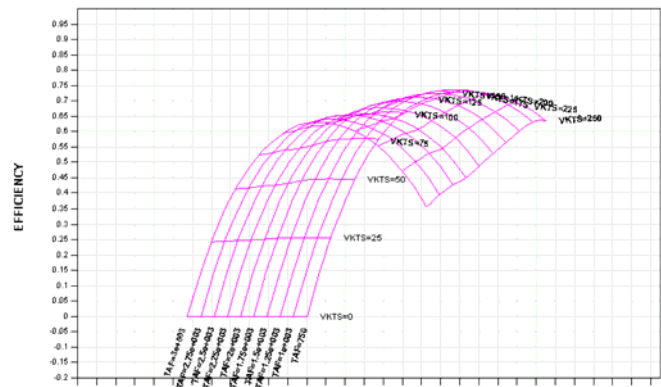

Figure 21 – Efficiency vs Total Activity Factor (TAF) vs Speed

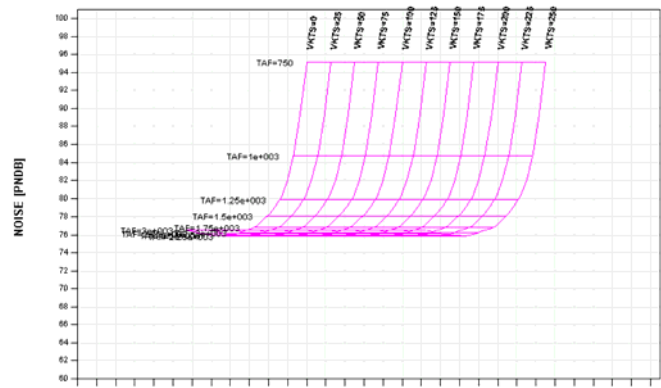

Figure 22 – Noise vs Total Activity Factor (TAF) vs Speed

Once the propulsor noise is reduced, the next biggest source is the engine. Worobel and Mayo identified four sources of engine noise; gearbox, case radiated, intake, and exhaust [19]. By choosing a direct drive, the Civetta avoids the gearbox source entirely. By choosing to use a liquid-cooled automobile engine, the Civetta has

dramatically lower case radiated noise due to the attenuating effect of the liquid cooling jacket and the lack of vibrating cooling fins. Intake noise is not fundamentally better in the Civetta, with the possible exception that the mid-mounted engine has a great deal of open space in the engine bay that allows for devices to muffle the intake. Similarly, the Civetta has a very large, empty volume available for exhaust muffling (Figure 23). This is particularly important as the exhaust noise source is by far the largest, and the most important parameter in muffler design is its volume. This availability of volume is in stark contrast to the tight cowling of tractor engine designs.

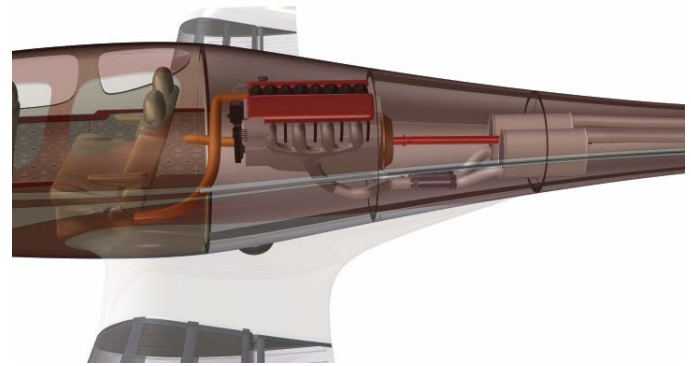

Figure 23 – Civetta Engine Bay

Emissions – Currently, certified aircraft engines are unregulated with respect to exhaust emissions. If PAVs are ever to increase in number, then this must end. By choosing an automotive engine, the tremendous amount of research and development in reducing emissions already done can be leveraged cheaply. The engine chosen is high performance, yet runs on unleaded fuel. Even without catalytic converters, it is much cleaner in unburned hydrocarbons than the aircraft engine because the liquid cooling, small cylinder bore, anti-knock sensor, and Lambda sensor allow reliable lean mixture operation. The air-cooled aircraft engine relies on rich mixtures for stable combustion and cooling, which guarantees unburned hydrocarbons. If Nitrous Oxide (NOx) and Carbon Monoxide (CO) are serious concerns, then the catalytic converter can be adopted immediately, albeit at an additional cost and weight. Because of the exceptionally large engine bay volume available, no design changes would be necessary.

While most of the attention has gone to minimizing community noise, the choice of an aft-mounted propulsor eliminates the top two sources of cabin noise, namely the interaction between the turbulent vortex being shed from the tractor propeller and the windscreen and side windows [22]. Given the much higher speed,

and therefore power setting, of the PAV, it is unlikely that automobile levels of noise can be attained because of wind noise and engine noise. Still, the levels can be made much lower than is typical today and any reduction in noise and vibration is welcome. There should also be some safety benefit to reduced cabin noise and vibration as well, by reducing pilot fatigue and improving communications.

Disposal – When only small numbers are produced, the recyclability of materials is of little concern. However, the intent of the PAV sector is to greatly expand the role of SEP aircraft in travel, necessitating vastly greater numbers. While the aluminum primary structure of the Civetta was chosen primarily for cost reasons, the recyclability and scrap value of aluminum means that not only can the airframe be recycled, but it actually will be. This is in stark contrast to composite structures, which are generally not recyclable and have very poor scrap values. One of the main reasons cited that composites are increasingly chosen for SEP aircraft production is low weight. The NASA PAV sector commissioned a study by Mark Anderson of Analytical Mechanics Associates to structurally analyze three skin stiffened aluminum structural concepts and two composite structural concepts for the Civetta wing [23]. His results indicated that the baseline skin stiffened aluminum structure was the lightest, eliminating the incentive for using composites.

Cost - Cost was ranked as the third most important of all of the barriers preventing widespread adoption of SEP aircraft for personal transportation. This is because it is the other measure that ultimately determines value and also determines the actual size of the market. Mode choices that are low cost, but of little value or are high value but high cost are both limited in total market size.

Even if the EoU and Pollution PAV priorities increase the utility of the SEP aircraft, the cost is much too high for a new, invigorated market to take off. Kraus noted that cost cutting of up to 20% during the 1980s had very little effect on sales [9]. What is needed is a rebalancing of design priorities in favor of radical reductions in cost at much higher levels of production, keeping in mind that the market will have to bootstrap itself up, meaning that there has to be a path from relatively low rates of production through to historically high rates of production.

Since the PAV sector intended to address cost through design, it was necessary to first determine where the major cost items were and then propose approaches to address them. Figure 24 shows a typical price breakdown for a GA aircraft [24].

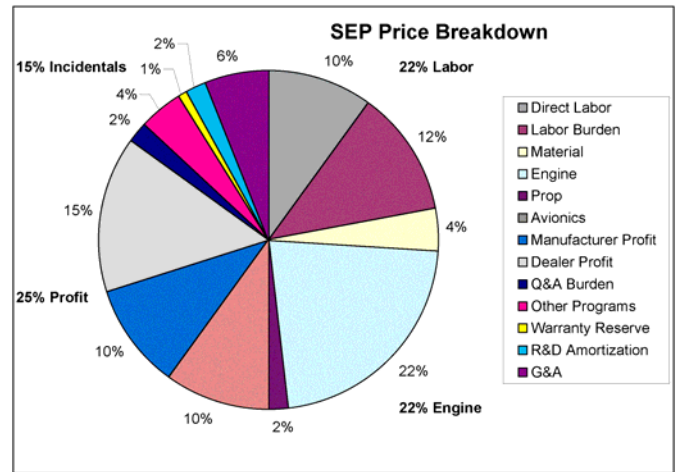

Figure 24 – GA Price Breakdown

It is immediately obvious that labor and engine account for nearly 50% of the price, that profit accounts for 25%, and that incidentals account for about 15%. Since price reductions of 20% are ineffective, and both profit and incidentals cannot be affected by design, the only option was to make radical cuts in labor and engine costs.

Labor Cost - A survey of historical best practices in aircraft production brought to our attention the construction and production methods that Republic Aviation used on their RC3 Seabee model (Figure 25)[25].



Figure 25 – Republic Aviation RC3 Seabee

Most aircraft manufacturers believed that there would be unprecedented increased civilian demand and the normal dramatic drop in military demand for aircraft after World War II ended. After having produced more P-47 Thunderbolts than any other American fighter type (15,686), Republic was in possession of a wealth of production time and material cost data, so a small group of engineers analyzed this data to see where cost could be taken out. They quickly realized that building a

civilian aircraft the way that they currently did was going to be prohibitively expensive, so they decided to use a radical construction method proposed by Alfred Boyajian that used deeply formed, heavy gage skins with few internal parts (Figures 26, 27). Nearly all of the internal structure was replaced by deeply formed skins, and all fastening was accessible by semiautomatic riveting guns from the outside.



Figure 26 – Republic RC3 Seabee Production Wing Skin Press Die

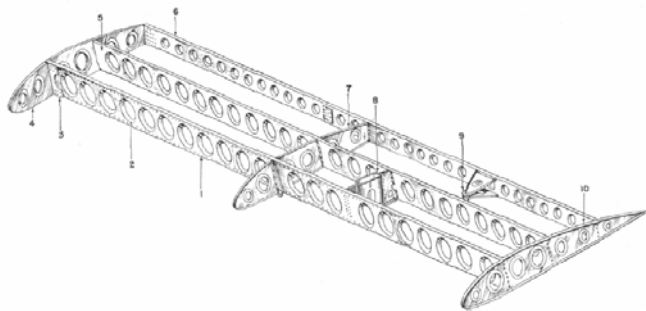

Figure 27 – Republic RC3 Seabee Production Wing

This was a complete departure from the conventional construction of many interlocking internal parts that required hand assembly, usually with poor access for fastening (Figure 28).

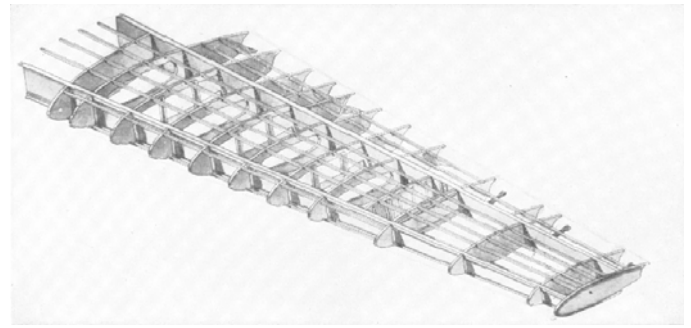

Figure 28 – Republic RC2 Seabee Prototype Wing

Republic's attention went well beyond simply reducing part count and fastening accessibility. They realized that operations, like heat treating, assembly, disassembly, deburring, reassembly, and manual multi-operation tooling reduced productivity unacceptably and unnecessarily. They compromised the structural material strength for better formability without any post treatment operations. They used semi-automatic riveting guns that clamped and punched holes in parts before upsetting the rivets instead of drilling so that disassembly and deburring and reassembly operations would be eliminated. They even designed and built their own automated wing assembly machine that was able to fasten the wing primary structure together in minutes. While the greatest impact of this philosophy was felt on the flying surfaces, as much of it as possible was also applied to the fuselage, yielding large cost reductions there as well.

All of this attention to detail and design for automated assembly yielded an overall airframe part reduction of 75% and a labor reduction of 92% with an increase in tooling cost of 100%. Figure 29 shows the relative effect of these design choices on airframe cost per pound as a function of units produced per year, in 1946 dollars.

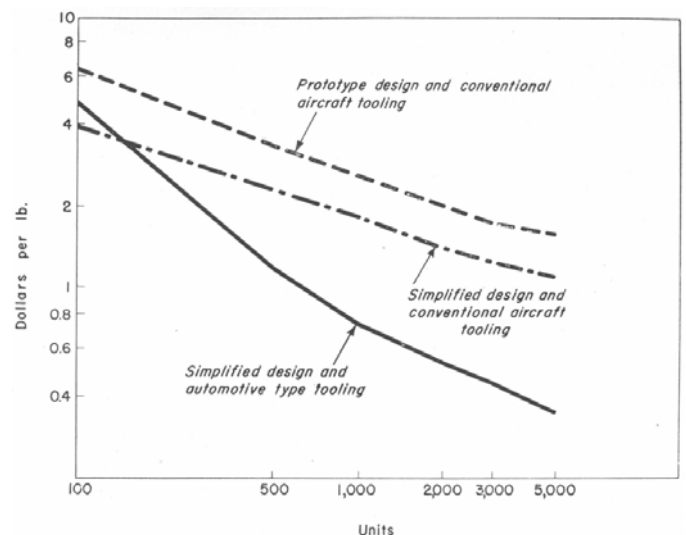

Figure 29 – Airframe Cost per Pound as a Function of Units produced

The top curve in Figure 29 is the conventional design and aircraft tooling. This is basically the same as is done in the aircraft industry today. The middle curve is for the simplified design and aircraft tooling. There is an immediate 38% cost reduction due to the lower part count, but the slope of the curve is essentially the same. This means that the increased productivity with increasing units is limited by the aircraft tooling. The lowest curve is for the simplified design and automotive type tooling. While there is an immediate increase of 25% in cost because of the increased tooling cost, the curve is on a completely different slope, paying off dramatically in productivity as units increase. It is this improved learning curve that holds the most promise for reducing PAV costs. There are two more important points to be made about these curves. First, even at only 100 units per year, the simplified design with automotive tooling is lower cost than the conventional design. Second, the increased tooling costs are more than made up for by productivity at approximately 150 units per year. While this is a lot of units for most manufacturers in today's market, this low rate needed for breakeven makes bootstrapping the market very plausible.

The NASA PAV sector adopted the Republic Aviation philosophy as a baseline, and worked with others to verify these assumptions. Munro and Associates, experts in lean design for the automotive industry, has been branching out into the aviation industry. They were funded to perform the same disassembly and cost analysis for the Republic Seabee that they do for major automotive manufacturers [26] (Figure 30). Much to their surprise, they were very impressed with the Seabee design. They did have constructive input on potential improvements, particularly with respect to modern fastening options like laser weld bonding and friction stir welding, but the overall philosophy and implementation was judged excellent. Munro came to the conclusion that the sale price for this fairly high performance aircraft would be about \$100,000, with standard avionics, at production rates of 4000 units per year. If true, this would be an excellent value and leave a large budget for those willing to upgrade to the NFD and H-mode avionics.



Figure 30 – Republic Seabee Disassembled by Munro and Associates

Figures 31 and 32 give an idea of where the Civetta would compare on Kraus' Figure of merit (F) and our objective value metric assuming that the NFD and H-mode avionics cost an additional \$50,000. While the objective utility (F) is about average, the value (utility/cost) is outstanding. Figure 32 indicates that just based on the objective value alone, that the Civetta would be very attractive when compared to current designs. The greater subjective value of the Civetta should make it just that much more attractive.

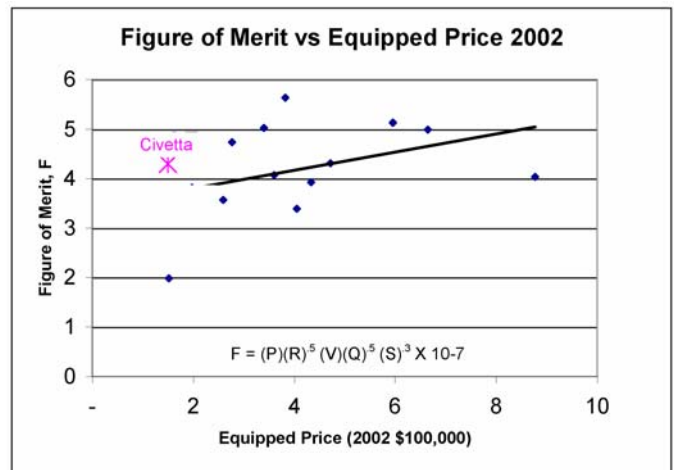

Figure 31 – Figure of Merit Correlation With Price, Civetta added

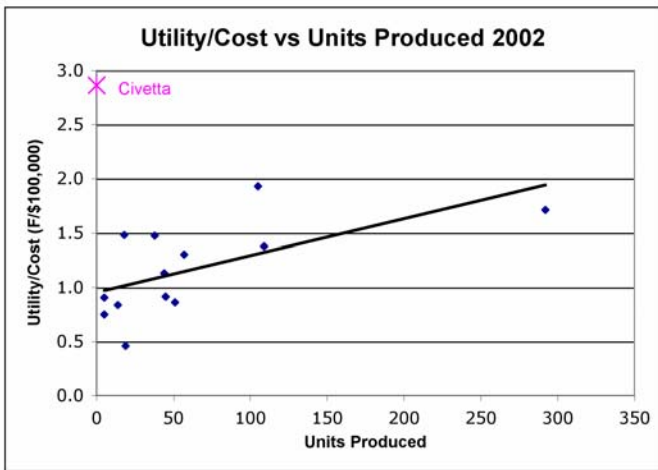

Figure 32 – Objective Value Correlation with Units Produced, Civetta added

Propulsion Cost – The only other major cost that could be addressed through design was that of the engine. While it might seem obvious that an engine designed for low cost would be worth pursuing, the evidence clearly shows that an engine at high rates of production will cost less than a similar, but simpler one at low rates of production. This is essentially the same effect as shown on Figure 29. Simplification is beneficial, but it is orders of magnitude less effective than efficient production at high rates. Since there is no possibility of getting the cost significantly down on an aircraft engine, we looked for an alternative that is already in high rate production and decided to live with it “as is.” The obvious choice was an automobile engine of some kind. Historically, most automotive engine conversions to aircraft use have been failures. The basic reason appears to be that the developers try to get aircraft engine performance out of an engine that is at a fundamental disadvantage because it has not been designed with similar compromises. For example, liquid cooling is heavier than air cooling, particularly when the whole system is taken into account. This doesn’t mean that there aren’t advantages to liquid cooling that may make it attractive, but to expect the liquid cooled engine to have the same power to weight ratio is unreasonable. The temptation to “hop up” the automotive engine to get a comparable power to weight ratio is difficult to resist, and usually results in a series of escalating decisions that both raise the cost of the engine and lower the reliability. It is just not possible to get aircraft engine performance and low cost out of an automotive engine at the same time. There have been four certified aircraft engines that have started as automotive engines. They are the Orenda OE-600, the Porsche PFM, the Toyota FV4000, and the Thielert Centurion 1.7. Of these, only the Thielert is currently being installed by an OEM on new airframes.

The Porsche PFM is a typical example of what happens when an automotive engine is retrofitted onto an airframe designed for an aircraft engine. Even after replacing most of the components for enhanced durability at high power levels, the engine added 91 kg (200 lb) to the empty weight, 13 kW (17 hp) to the power, \$100,000 to the price and actually dropped top speed by 9 km (5 kts). It is no wonder that it sold poorly and that Porsche is buying back the engines to destroy them to reduce liability exposure.



Figure 33 – Chevrolet LS-1 Engine Dynamometer Test

The key to getting the cost benefit of an automotive engine is to leave it as much of an automotive engine as possible, and design an airframe to work well with it. Because of previous experiences, there is a general belief that the automotive engine can’t operate at the high power duty cycles that the aircraft engine does, which is true if maintaining the same power to weight ratio is important. If it is not important, then the engine can be de-rated to a point that it will function just as well as the aircraft engine, albeit at a heavier weight. To prove this, Iannetti ran his preferred Chevrolet LS-1 Corvette engine in a dynamometer, simulating the Federal Aviation Administration’s (FAA’s) 150-hour FAR part 33.49b engine endurance test [27] (Figure 33). While the test did not simulate the vibratory characteristics of the long shaft and Q-fan, it did show that the engine was easily capable of passing the same test that all piston aircraft engines must pass from a duty cycle perspective.

By choosing an automotive engine, the reduction in propulsion cost is dramatic. We estimate that the TCM IO-550 currently costs approximately \$40,000 Y2006 [28], while the Chevrolet LS-1 costs about \$7,000 Y2006 in the crate and \$12,000 Y2006 installed. This is based on the retail prices paid for the engine tested. Iannetti stated that when ASA racing bought 300 engines from

General Motors, that it required 3 hours of production and that they received a volume discount of approximately \$2,000 per engine. This indicates that our cost estimates are conservative.

The trade off for this cost reduction is that the LS-1 is heavier than the IO-550. Tables 1 and 2 compare the installed weight breakdown of the complete propulsion systems.

This 96 kg (211 lb) increase is significant. The increased empty weight must be carried all of the time and is unproductive. It is the equivalent of having an extra adult passenger and baggage along at all times, but not actually benefiting from the extra seat. Still, the cost reduction is substantial and works out to \$293/kg (\$133/lb).

	Continental IO-550-L kg	Chevrolet LS-1 kg	Change kg
Propulsion	265	361	96
Basic Engine	196	197	1
Air Induction	2	7	5
Exhaust	7	14	6
Cooling	5	27	22
Fuel System	11	11	0
Oil Cooler	2	14	11
Controls	2	0	-2
Starting	8	0	-8
Propulsor	32	63	30
Drive Line	0	29	29

Table 1 – Installed Propulsion Weight Comparison (SI units)

	Continental IO-550-L lb	Chevrolet LS-1 lb	Change lb
Propulsion	584	795	211
Basic Engine	431	434	3
Air Induction	5	15	10
Exhaust	16	30	14
Cooling	10	59	48
Fuel System	23	24	1
Oil Cooler	6	31	25
Engine Controls	3	0	-3
Starting	19	0	-19
Propulsor	72	138	66
Drive Line	0	65	65

Table 2 – Installed Propulsion Weight Comparison (Imperial units)

One common criticism of choosing an automotive engine is that most people assume that it cannot be certified. Given the very attractive cost savings, the NASA PAV sector commissioned a study to explore the feasibility of not only certifying a minimally modified automobile engine, but to do so with the absolute minimum regulatory burden on the OEM as possible. Clearly, automotive derived engines have already been certified for SEP aircraft use, but they were invariably highly modified. Most have assumed that this was at the direction of the FAA, but talks with the FAA have proven that this was simply not the case. The manufacturers did what they did on their own; the FAA only evaluated their application as presented. The manufacturers probably made decisions based on a complex weighting of many factors, with FAA certification being just one. Our belief is that the desire to have a retrofit market started a cascading spiral of decisions that all led to the same attempt to have an automotive based engine compete directly with the specially designed aircraft engine. To find out what really happened during the certification of the last two automotive based engines, Klinka evaluated the FAA documentation for the Toyota FV4000, and the Thielert Centurion 1.7 [29]. What emerged was a picture of two very different approaches that both yielded high performance, but expensive engines. After extensive document correlation between FAA regulations, advisories, policy documents and industry's consensus based quality standards, it appeared that it was indeed possible to come up with a roadmap that allowed the FAA to accept adherence to the newest quality standards as evidence of FAR compliance. If true, this would allow currently shipping engines, intended for ground uses, to be certified for SEP aircraft use with little increase in cost. Because of this encouraging result, the NASA PAV sector has funded Klinka to work with the FAA as a virtual applicant to provide a roadmap for automotive engine certification [30]. The potential benefits of this effort to the GA community are that it will enable a radical cost reduction with defined and predictable procedures for certification. Also, these cost reductions are required to offset the cost increase of the low-noise Q-fan.

The Q-fan cost estimate for a conventional fan design is about twice that of a propeller. Based on a cost of \$14,600 Y2006 [28] for a propeller, this would yield a Q-fan cost of \$30,000. This was undesirably high, so the NASA PAV sector had AeroComposites Inc. (ACI) investigate an innovative blade and hub design for the fan, with the goal of reducing the fan part of the cost to below \$44/N (\$10/lb) of static thrust [31] (Figure 34). While the design is currently only conceptual, ACI believes that the goal is close to what is achievable and would yield Q-fan cost of less than \$10,000. ACI also believes that the all-composite fan would weigh between 60 to 70% that of the metallic baseline.

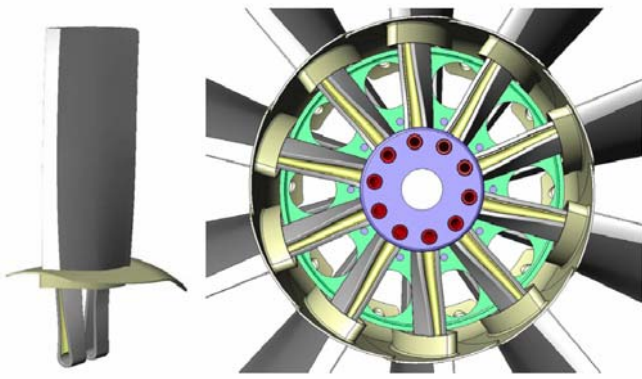

Figure 34 - ACI Low Cost, Light Weight, Variable Pitch Fan Design

Adding together the cost of the engine and propulsor, the LS-1 and Q-fan should range between a high of \$42,000 and a low of \$22,000. This compares to the IO-550 and propeller at approximately \$54,600. Continuing development of the ACI fan is highly desirable for both cost and weight reasons.

The synergistic combination of the automotive engine and the Q-fan achieves a dramatic reduction in noise and a significant reduction in cost, at a moderate increase in weight. The much lower cost of the engine more than counterbalances the increased cost of the Q-fan and the relatively high RPM operation of the Q-fan reduces the weight penalty of the engine by allowing it to operate at a competitive power. By playing the strengths and weaknesses of both components off against one another, NASA PAV stretch goals were achieved with only moderate performance losses.

Since operating costs are also important, the efficiency of the propulsor is important. Unfortunately, the Q-fan is significantly less efficient than a propeller. The Civetta's Q-fan is biased toward low noise and is estimated to have an installed peak cruise efficiency of 0.68. While this may seem low when compared to the often-quoted 0.85 for a propeller, that quote is for an uninstalled propeller. There is little information on installation losses for tractor propeller SEP aircraft, but one source claims that the actual propulsive efficiency is much lower than is commonly thought. Norris reported that his personal aircraft, a Luscombe, had a peak propulsive efficiency of 76%, which dropped as airspeed increased to 62% (Figure 35) [32]. While this may not be typical, it does indicate that the final installed efficiency of the Q-fan may not be quite as relatively poor as is commonly thought. This question deserves more scrutiny before any final judgments are made.

FLYING THE THINKING PILOT'S WAY

LUSCOMBE 8E
Drag - Power 1250# GW

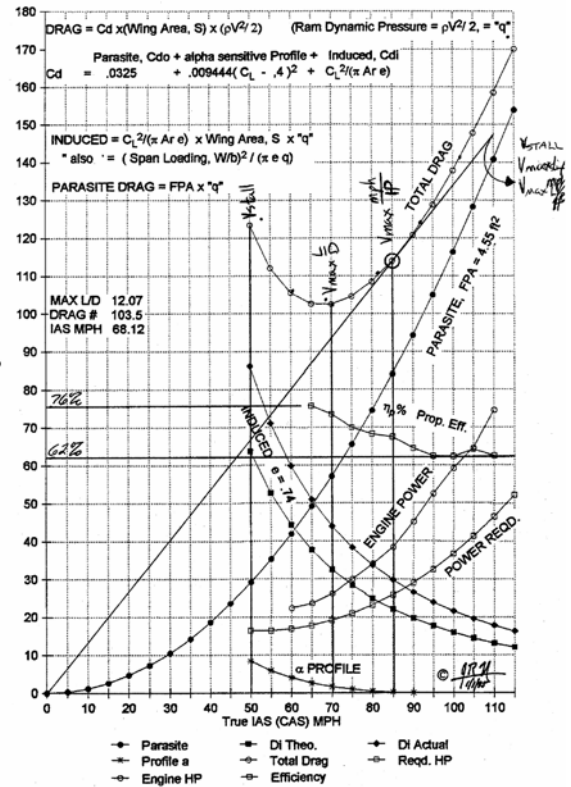

Figure 35 – Installed Propulsive Efficiency of a Tractor Propeller SEP Aircraft

There is also some indication that modern tools may be able to improve efficiency over the Hamilton-Standard design without increasing noise. As part of their study, ACI had Avid LLC redesign their fan blade shapes and they reported that they could reduce the fan source 3 peak dBA with no change in efficiency using the ducted version of MIT's Xrotor program [33]. When this design was analyzed with a higher order code (Figure 36), Ni reported that the efficiency was as high as 0.78 in cruise [34].

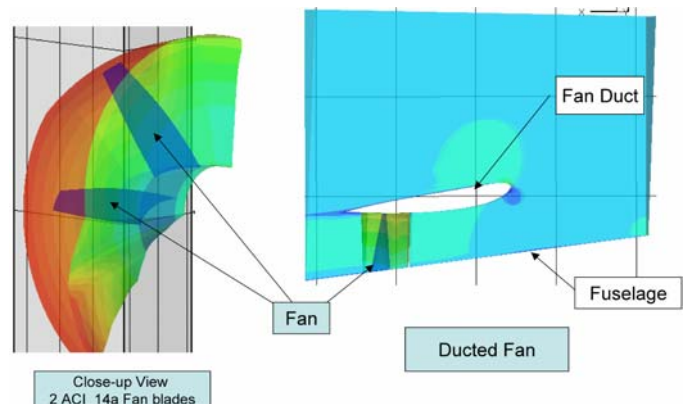

Figure 36 – Computational Fluid Dynamics Analysis of Avid-ACI's Improved Q-fan

If the installed cruise propulsive efficiency can indeed be raised from 0.68 to 0.78, then the Civetta will go from a fuel economy of 5.4 km/l (12.8 mpg) to 6.3 km/l (14.7 mpg) at the economy cruise speed of 302 km/hr (163 kts), which is an improvement of 13%. This improvement is highly desirable and begs for continued work.

Side Benefits – While each of the design choices is traceable back to EoU, pollution, or cost, often these choices yielded other benefits.

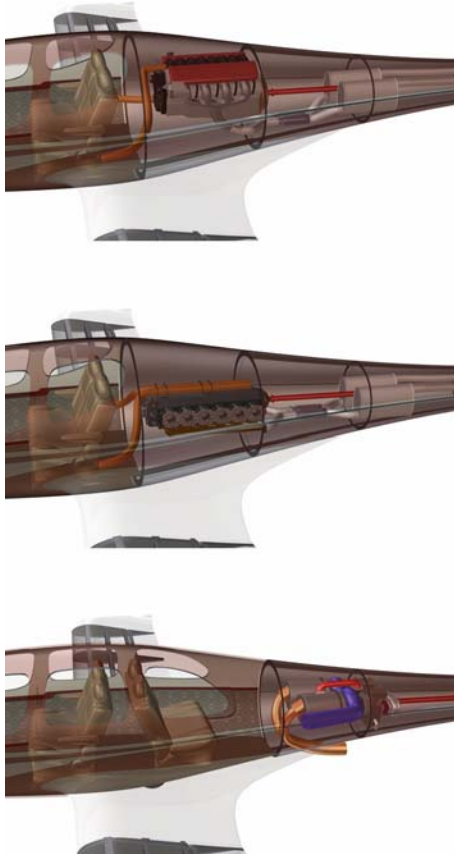

Figure 37 – Civetta with Automotive V8, Aerodiesel O12, Gas Turbine Twinpac Engine Installations

Mid-mounted Engine – By putting the engine bay in the middle of the fuselage, a great deal of flexibility in engine selection is engendered. This is because the engine is very close to the CG, so large changes in weight are easily accommodated, and the bay is voluminous, so that very different sized and shaped engines are easily accommodated (Figure 37).

The mid-mounted engine also improves visibility by lowering the front cowl and moving the wing behind the pilot (Figure 38).



Figure 38 – Interior View comparison of Cessna 150 (top) and Civetta (bottom)

Aft Mounted Ducted Propulsor – The aft-mounted Q-fan has several side benefits. First, it looks like the turbofan engines that most people associate with modern aircraft. Second, the duct forms a visible, physical barrier to the rotating fan, which has both real and perceived safety benefits. Third, the duct is actually smaller than the fuselage, making the event of a bird strike or Foreign Object damage (FOD) much less likely to occur. Last, the duct will tend to retain a blade if it is shed, which is safer.

Automotive Engine – There are several side benefits to the automotive engine. First, having eight pistons and higher RPM output is smoother which is both more comfortable for the passengers and makes it much easier to design the long drive shaft. Second, the fully balanced crankshaft and torsion damper reduces vibration, which is both more comfortable and safer because pilot fatigue is reduced. Third, the liquid cooling allows safe cabin heating without the possibility of carbon monoxide poisoning, which is safer. Fourth, liquid cooling has potentially lower cooling drag, so performance may be better than currently estimated. Last, the replacement cost of the engine is less than the overhaul cost of current aircraft engines. By replacing the basic engine with a new one, the engine really is “zero timed.”

CONCLUSION

The current generation of General Aviation aircraft is facing tremendous challenges that threaten to relegate the Single Engine Piston (SEP) aircraft market to a footnote in the history of U.S. aviation. This unhappy state is the result of low travel value due to low utility and high cost. The pilot base that supports this branch of aviation is ageing and shrinking. Unless something is done to take the SEP aircraft from being an expensive toy for the few to a rational mode choice for many more, the inevitable result will be a steady decline in sales and activity. The barriers to widespread acceptance of self-operated light aircraft were identified and prioritized. Those barriers that can be addressed through synergistic vehicle design were identified along with technical approaches to overcome them. Evaluation of these approaches required a vehicle to give context so that the relative strengths and weaknesses could be balanced in a design that gave up some level of

traditional performance metrics in return for dramatic improvements in the NASA Vehicle Systems Program (VSP) Personal Air Vehicle (PAV) sector priorities. The result was a technology investment portfolio tool that guided fundamental work in long neglected areas while still remaining relevant because, in the end, any new technologies developed have to buy their way onto an aircraft that people will actually want to buy. The resulting work, sponsored by NASA, has already yielded significant results despite the limited time allowed for execution.

ACKNOWLEDGMENTS

The Personal Air Vehicle sector of the NASA Vehicle Systems Program would not have existed without the vision and support of many people. First among them is Mark Moore of Langley, who struck out boldly on his own and almost through sheer force of will gave the PAV its start. Dennis Bushnell of Langley gave crucial early support and continues to do so till this day. Richard Wlezien of the NASA Vehicle Systems Program turned an upstart effort into one of the six official vehicle sectors with an actual budget to do research. Robert McKinley who lead the VISTA office and who's support was crucial to getting the PAV accepted as one of the sectors. Bob Yang of the NASA SBIR/STTR office who's support for a PAV subtopic resulted in much of the work done. Terry Hertz of NASA Headquarters who pitched in with study funding from the RACS and RSCA projects. Bob Evangelista and Rob Kline who's incredible animation skills and good natures are responsible for many of the graphics in this paper and the full motion animations that helped us convey our message. Francesco Iannetti of Design Ideas who went the extra mile to make sure that the 150-hour engine test was of high quality and gave us the early credibility that we had lacked. Chris Miller of NASA Glenn who's early work identified deficiencies in the duct design and who's continued support help make the design work well. Frank Flemisch and Ken Goodrich of NASA Langley whose NFD and H-mode work could make all the difference. Mark Rumizen and Dan Kerman of the FAA who's support and council have been enlightening and encouraging. And finally, the numerous contractors who became believers the more that they scrubbed our numbers (Munro, AMA, ACI, NexT).

REFERENCES

- Schafer, Andreas, "Regularities in Travel Demand: An International Perspective," *Journal of Transportation and Statistics* Volume 3 Number 3, Bureau of Transportation Statistics, Washington DC, December 2000.
- Schafer, Andreas, "Modeling Global Mobility: World Passenger Travel through 2050," United States Department of Transportation, Washington DC, <http://scitech.dot.gov/policy/vision2050/agenda.html>, 2000.
- "Summary of Travel Trends 1995 Nationwide Personal Transportation Survey," U.S. Department of Transportation Federal Highway Administration, Washington, DC, 1999.
- "American Travel Survey," United States Department of Transportation Bureau of Transportation Statistics, Washington DC, <http://www.bts.gov/programs/ats>, 1997.
- "Airline Data and Statistics," United States Department of Transportation Bureau of Transportation Statistics, Washington DC, http://www.bts.gov/programs/airline_information/.
- American Automobile Association Website, <http://www.aaa.com>.
- Air Transport Assotiation Website, <http://www.airlines.org>.
- Wingrove, Earl R. III, Jing Hees, James A. Villani, "The Integrated Air Transportation System Evaluation Tool," NS104S1, Logistics Management Institute, McLean, VA, 2001.
- Kraus, E. F., "Technical Thresholds For Revitalizing General Aviation," AIAA-87-2933, American Institute of Aeronautics and Astronautics, Herndon, VA, 1987.
- Kraus, E. F., "Updated Figure of Merit Calculations, Rev B", Personal Correspondence, 2004.
- "General Aviation Statistical Databook 2005," General Aviation Manufacturers Association, Washington DC, 2006.
- Gartenberg, Itzhak, "Analysis of the U.S. Market for Piston-Engined General Aviation Aircraft," NASA CASI (301) 621-0390.
- Cessna Advertisement, *Aviation Week* Volume 1, McGraw-Hill, New York, NY, 1943.
- Schaper, David, "A Navy Base Closes, and a Town Thrives," National Public Radio Morning Edition, <http://npr.org>, Washington, DC, 2004.
- Flemisch, Frank O., Ken Goodrich, et. al, "The H-Metaphor as a Guideline for Vehicle Automation and Interaction," NASA TM—2003-212672, National Aeronautics and Space Administration, Washington, DC, 2003.
- Worobel, Rose, Millard G. Mayo, "Advanced General Aviation Propeller Study," NASA CR-114289, National Aeronautics and Space Administration, Washington, DC, 1971.
- Conversation with Jeff Viken, Co-designer of the VK-30, 2006.
- Hessenaur, Don, "Torsional Resonance," *Contact! Magazine* Issue 9, Hanford, CA, <http://www.contactmagazine.com/backissu.html>.
- Worobel, Rose, Millard G. Mayo, "Q-fans for General Aviation Aircraft," NASA CR-114665, National Aeronautics and Space Administration, Washington, DC, 1973.
- Metzger, F. B., R. W. Menthe, G. J. McColgan, "Performance and Noise of a Low Pressure ratio Variable Pitch Fan Designed for General Aviation Applications," NASA CR-159246, National

Aeronautics and Space Administration, Washington, DC, 1980.

21. HSQFAN Q-Fan™ Analysis Program, Aerospace Systems Design Lab, Georgia Institute of Technology, 2004.
22. Patrick, Howard V. L., "Cabin Noise Characteristics of a Small Propeller Powered Aircraft," AIAA-86-1906, American Institute of Aeronautics and Astronautics, Herndon, VA, 1986.
23. Anderson, Mark, "PAV Structural System Study," AMA Report No. 05-11, Analytical Mechanics Associates, Hampton, VA, 2005.
24. "Potential Structural Materials and Design Concepts for Light Aircraft," San Diego Aircraft Engineering Inc, NASA CR-1285, National Aeronautics and Space Administration, Washington, DC, 1969.
25. Neville, Leslie E., "Aircraft Designers' Data Book," McGraw-Hill, New York, NY, 1950.
26. Munro and Associates, "Low Cost Lean Design & Manufactured PAV," NASA STTR 2005 Phase I Final Report, T7.01-1749, National Aeronautics and Space Administration, Washington, DC, 2005.
27. Iannetti, Francesco, "Evaluation of Automotive Engines for the Propulsion System of Affordable Personal Air Vehicles," Design Ideas Inc., Raleigh, NC, 2003.
28. Cook, Marc E., "Aero SUV 1999 Sweepstakes Persuasion of Power," AOPA Pilot, Aircraft Owners and Pilots Association, Frederick, MD, October 1999.
29. Klinka, Brian, "Innovative Airworthiness Certification Concepts and Quality Assurance Processes for the PAV Final Report," STTR Phase I Proposal No. 04-I T7.01-9838, National Aeronautics and Space Administration, Washington, DC, 2006.
30. Klinka, Brian, "Certification of the COTS Engine and Naturalistic Flight Deck Systems for the Next Generation of Small Aircraft," STTR Phase II Proposal No. 04-II T7.01-9838, National Aeronautics and Space Administration, Washington, DC, 2006.
31. "Low Cost/Low Noise Variable Pitch Ducted Fan Personal Air Vehicle (PAV) Research For Rural, Regional, And Intra-Urban On-Demand Transportation Final Report," STTR Phase I Proposal No. 04-I T7.01-9955, National Aeronautics and Space Administration, Washington, DC, 2006.
32. Norris, Jack, Andy Bauer, "Zero Thrust Glide Testing," Sport Aviation Magazine, pp 53-60, Experimental Aircraft Association, Oshkosh, WI, March 1995.
33. "NASA PAV Fan Design," ACI0105B, Avid LLC for AeroComposites Inc., Blacksburg, VA, 2006.
34. Ni, Ron Ho, "AeroComposites Inc. Aero-Acoustic Studies NASA PAV Ducted Fan, 3D CFD Results of Aerodynamic Analyses," Ni for AeroComposites Inc., Kensington, CT, 2006.

CONTACT

Andrew Hahn is an aerospace engineer at the NASA Langley Research Center in Hampton, VA and may be contacted through e-mail at Andrew.S.Hahn@nasa.gov.

ADDITIONAL SOURCES

35. Moore, Mark D., "Personal Air Vehicles: A Rural / Regional and Intra-Urban On-Demand Transportation System," AIAA-2003-2646, American Institute of Aeronautics and Astronautics, Herndon, VA, 2003.
36. Moore, Mark D., "NASA Personal Air Transportation Technologies," SAE 2006-01-2413, Society of Automotive Engineers, Warrendale, PA, 2006.
37. Moore, Mark D., "The Third Wave of Aeronautics: On-Demand Mobility," SAE 2006-01-2429, Society of Automotive Engineers, Warrendale, PA, 2006.

DEFINITIONS, ACRONYMS, ABBREVIATIONS

CG: Center of Gravity

DtD: Door-to-Door

EoU: Ease-of-Use

EQuiPT: Easy-to-use, Quiet, Personal Transportation

F: Kraus' Figure of merit

FAA: Federal Aviation Administration

GA: General Aviation

H-mode: Haptic flight control system operation mode

NFD: Naturalistic Flight Deck

NASA: National Aeronautics and Space Administration

OEM: Original Equipment Manufacturer

PAV: Personal Air Vehicle

RPM: Revolutions Per Minute

SEP: Single Engine Piston

TAF: Measure of the Solidity of a Propeller

VSP: Vehicle Systems Program