

Development of a Gravity-Insensitive Heat Pump for Lunar Applications

Gregory S. Cole¹, Robert P. Scaringe¹, Lawrence R. Grzyll¹, Michael K. Ewert²

¹ *Mainstream Engineering Corporation, 200 Yellow Place, Rockledge, FL 32955*

² *NASA JSC, 2101 NASA Road One, Houston, TX 77058*

Abstract. Mainstream Engineering Corporation is developing a gravity-insensitive system that will allow a vapor-compression-cycle heat pump to be used in both microgravity ($10^{-6}g$) and lunar ($1/6g$) environments. System capacity is 5 kW to 15 kW at design refrigerant operating conditions of 4.44°C and 60°C evaporating and condensing temperatures, respectively. The current program, performed for NASA Johnson Space Center (JSC) and presented in this paper, includes compressor performance analysis, detailed system design, and thermal analysis. Future efforts, including prototype fabrication, integration of a solar power source and controls, ground-testing, and flight-testing support, are also discussed.

Keywords: Heat Pump, Microgravity, Lunar

PACS: 07.20.Pe

INTRODUCTION

President George W. Bush's Vision for U.S. Space Exploration includes the goal of extending the human presence across the solar system, starting with a human return to the Moon no later than the year 2020, in preparation for human exploration of Mars and other destinations. NASA JSC is developing heat rejection systems for eventual use on exploration vehicles and lunar/planetary outposts to help meet these goals. More powerful devices, greater power density, and longer-term missions will necessitate the use of heat pumps to reject heat from future space-based systems. These heat pumps must be able to operate in both microgravity ($10^{-6}g$) and lunar ($1/6g$) environments.

Terrestrial heat pump compressors rely on gravity for proper oil circulation in bearings, seals, and other contact surfaces, as well as proper refrigerant/oil management in two-phase heat exchangers. Mainstream Engineering Corporation has been investigating several oil-less vapor-compression compressor concepts, including the use of gas bearings, magnetic bearings, self-lubricating materials, permanently sealed (greased) bearings, and other compressors that do not require lubrication such as diaphragm compressors. Vapor-compression systems/compressors that are currently flying or have flown in microgravity space environments include Mainstream's oil-less reciprocating compressor, which is currently cooling the International Space Station's (ISS) refrigerated centrifuge (Grzyll and Cole, 2000) and the Enhanced Orbiter Refrigerator Freezer (EOR/F) compressor (Paul, 2004), an oil-less diaphragm compressor that was lost during the Space Shuttle Columbia tragedy.

Recognizing the need to develop a gravity-insensitive heat pump to for future exploration vehicles and lunar/planetary outposts, NASA JSC has been performing research aimed at the conceptual design and ground-based testing of components and systems for gravity-insensitive heat pump applications. The gravity-insensitive heat pump program is part of a larger program to develop thermal control systems for space exploration that also includes radiator, insulation, porous media heat exchangers, working fluids, and sublimators. The majority of the gravity-insensitive heat pump research and ground-based testing has focused on the development of a solar heat pump that uses photovoltaics to generate the required electrical power to the system (Ewert, 1993; Ewert, Keller, and Hughes, 1996; Ewert, 1998; Morton, et al., 1998; Ewert, et al., 1998; and Ewert and Bergeron, 2000). Mainstream has also

been involved in Air Force-sponsored work aimed at developing a low-lift heat pump for high-power (25 kW) spacecraft heat thermal control (Grzyll, 2000; Grzyll, et al., 2001; and Grzyll, 2006). Mainstream designed a magnetic-bearing centrifugal compressor as part of this program.

The research referenced above serves as basis for Mainstream's current effort being performed for NASA JSC and described in this paper.

REQUIREMENTS

Heat Pump Specifications

In general, heat pumps are comprised of a compressor, evaporator, condenser, control device, and an optional regenerative suction line heat exchanger. The gravity-insensitive heat pump of current interest is designed to acquire heat from an Internal Thermal Control System (ITCS) and reject heat to an External Thermal Control System (ETCS). The ITCS transfers heat from the load to the evaporative heat exchanger via a single-phase pumped loop containing water or a water/propylene glycol mixture. The ETCS transfers heat from the condensing heat exchanger to an external radiator via a single-phase pumped loop containing water/propylene glycol mixture or other heat transfer fluid. An ITCS to ETCS heat exchanger for direct exchange of heat in heat pump "off" or "night" mode and solar power operation is required, but is not included in the size and weight requirements below. The performance specifications set forth by NASA JSC include the following:

1. The system shall use vapor-compression heat-pump technology with a non-chlorofluorocarbon refrigerant.
2. The design point shall be 4.44°C refrigerant saturation temperature at the evaporator and 60°C refrigerant saturation temperature at the condenser.
3. The system shall be able to accept a maximum continuous heat load up to 15 kW (or more) and a minimum continuous heat load as low as 5 kW (or less) and intermediate heat loads between the minimum and maximum from the ITCS water loop at the design point.
4. The system shall be able to automatically control the exit water temperature of the ITCS liquid heat exchanger within the range of 1.5°C to 15°C \pm 1.5°C for the load range stated above.
5. The system shall be able to reject the accepted heat load plus the compressor waste heat to the ETCS pumped liquid loop at an elevated temperature. The temperature profile of the ETCS shall simulate a radiator loop for lunar applications, where the heat pump system temperature lift does not exceed 50°C (ITCS to ETCS).
6. The system shall be capable of operating within an un-pressurized volume of a spacecraft not to exceed 1 m³, excluding direct ITCS to ETCS heat exchanger.
7. The total mass shall not exceed 130 kg, excluding the direct ITCS to ETCS heat exchanger.
8. Electrical power consumption of the heat pump system at any required heat load shall not exceed 59% of its heat removal capacity (i.e., Coefficient of Performance > 1.7) at the design point.
9. The system shall be designed so that the orientation with respect to gravity can be changed from 0° (vertical) to \pm 90° (horizontal) to 180° (upside down) to assess the gravity dependence of the system.
10. System design life should be 35,000 hours or more with a 50% duty cycle (17,500 hours on/ 17,500 hours off, cumulative).
11. The system shall be designed for NASA C-9B flight testing including structural consideration (factor-of-safety greater than or equal to 2.0 for take-off/landing and in-flight loads), aircraft loading, and liquid containment. Other specialty engineering requirements include pressure/vacuum system requirements in accordance with JPR-1710, 13C and section 2.3.1-3 of AOD 33897, and electrical system design requirements in accordance with the National Electric Code.

- The heat pump shall be designed and insulated such that it can be tested in ambient Earth conditions without forming external condensation or tested at thermal vacuum conditions representing a shrouded area of a lunar spacecraft.

Compressor Specification

NASA JSC specified that the heat pump shall use a 54-mm Heli-Rotor™ rotary screw compressor by Fairchild Controls Corporation (Figure 1) or functionally equivalent, commercial, off-the-shelf compressor. However, no equivalent compressors are commercially available. This recommendation was based on a technical memorandum by Lockheed Martin Space Operations (Paul, 2004).

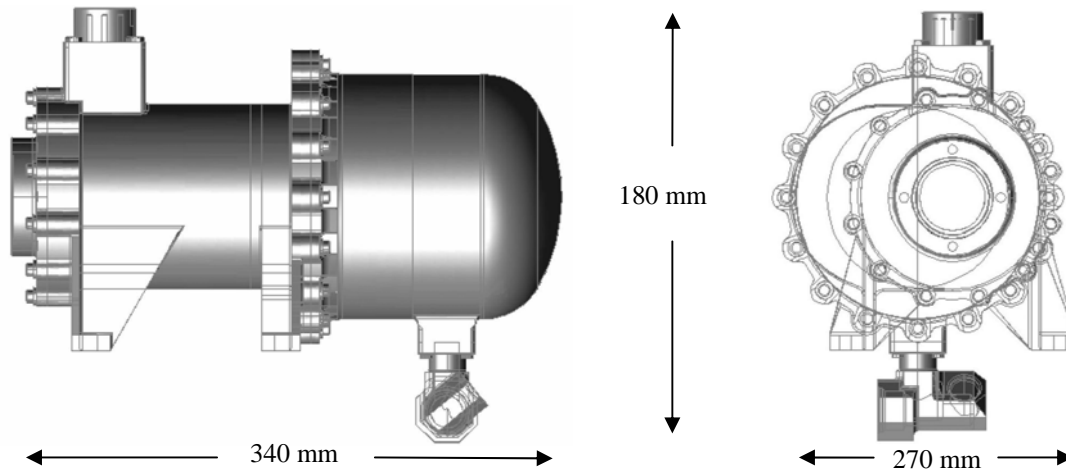

FIGURE 1. Fairchild 54-mm Heli-Rotor rotary screw compressor

The Fairchild compressor is a positive displacement, hermetic, dual-screw-type compressor containing unique features for enhanced life. It has been developed over a half century to the present configuration, which is utilized in the Longbow Apache environmental control system. The compressor is specifically designed for airborne applications where ruggedness is required for vibration resistance and high reliability is needed for long life. No inlet or exit valves are required, and unlike reciprocating or centrifugal compressors, the Heli-Rotor compressor can inject large quantities of liquid refrigerant without damage. This characteristic is particularly important when encountering liquid flow back associated with system start-up and starting at cold ambient conditions. Carefully selected rolling element bearings are cooled by the refrigerant and only require a small amount of oil for lubrication. The compressor satisfies the heat pump specifications provided above and is in production for the Longbow Apache. The compressor is insensitive to installation attitude and performance in a microgravity ($10^{-6}g$) environment is expected to be acceptable (NASA JSC, 2006).

Mainstream will perform additional evaluation of the Fairchild compressor to ensure that long-term operation in microgravity and lunar environments is possible. Specifically, the oil management system for bearing lubrication will be evaluated for long-term microgravity performance. In typical terrestrial systems, oil mixes with the refrigerant and is passed throughout the remainder of the heat pump system. Special precautions must be taken to ensure that oil is returned to the compressor. This can be accomplished through an oil separator at the compressor discharge or special design of the heat exchangers to prevent oil trapping. Prevention of oil trapping is complicated in space environments due to gravitational considerations. Additionally, if oil is circulated through the heat exchangers, the effect on heat exchanger performance must be considered.

SYSTEM DESIGN

NASA selected refrigerant HFC-134a as the working fluid of the heat pump. The performance of the Fairchild compressor with HFC-134a is rated within the specified requirements. Both the evaporator and condenser will be single-circuit, counter-flow, tube-in-tube heat exchangers that are optimized for stability, performance, and gravity-independent operation. Sizing will be based on optimal velocity for reduced pressure drop (efficiency), approach temperature (temperature difference between the refrigerant and water), and size. In addition, high velocities will be maintained to prevent pooling of lubrication oil. The overall heat pump system will include structural framing sized to fit through the cargo door and into the test cabin of a NASA C-9B test flight aircraft. A 2-inch dynamic clearance will be maintained to avoid the risk of damaging the aircraft structure.

A commercial thermostatic expansion valve (TXV) will be used control the superheat entering the compressor. TXVs are simple control devices used in most commercial heat pumps. The bulb is charged with a selectable fluid and charge type (liquid, gas, liquid-cross, gas-cross, adsorption, etc.). A single-phase or adsorption charge is most suitable for micro-gravity environments. Alternatively, an electronic expansion valve (EXV) will be implemented if more complicated control is required as the design proceeds, such as the compressor cycling on/off for low-lift or low-capacity operation. EXVs can also be used as a pressure unloader during cycling to minimize the head pressure that the compressor must start against. EXVs require more sophisticated control, with control logic being provided from a feedback controller on an electronic circuit board. The control board will require liquid cooling in thermal vacuum environments because it is not attached to the thermal system except through control wires. Further, EXVs typically use stepper motors that dissipate heat to the surrounding environment. Special precautions will be required to allow the heat from the stepper motor to dissipate to the heat pump system.

A commercial variable frequency drive (VFD) with sensorless control will be selected to control the motor of the Fairchild compressor. The initial specification from NASA required a 28-VDC input to the VFD based on legacy space systems. The cooling capacity and power requirement for this system is much larger than prior and existing systems and would result in extremely high amperage and large conductors. Therefore, NASA has allowed for increased input voltage to the VFD, the maximum being set by the primary voltage of existing solar collectors (300–400 VDC). This also allows commercial VFDs to be used without additional development.

All power conversion processes have inefficiencies, which result in waste heat that must be dissipated. In commercial, ground-based converters of this size range, waste heat is typically dissipated to the surrounding air. Larger-capacity, ground-based converters are typically water-cooled. In a thermal vacuum environment of space, heat cannot be dissipated to air and must be dissipated to liquid loops similar to large-capacity converters. Controller waste heat will be dissipated to the ITCS, ETCS, or heat pump loop. The selection of loop is dependent on the temperature and load requirements for the controller. From an efficiency perspective, the ETCS would be the most desirable cooling loop for the compressor controller. However, this loop operates at the warmest temperature and may not be cool enough to transfer heat from the VFD while maintaining power electronics at reliable temperatures.

EXPECTED RESULTS

Based on a preliminary assessment, Mainstream engineers expect that a gravity-insensitive heat pump can achieve the specifications set forth by NASA. The assessment resulted in the following characteristics:

- Weight: 115 kg
- Volume: 0.83 m³
- Efficiency: COP of 1.7 at design point

These values are currently being validated.

FUTURE WORK

The current program will result in a preliminary design of the gravity-insensitive heat pump system described above. It will include a thermal analysis report, verification and validation documentation, and a safety analysis and hazard report. The design will include complete component selection and validation of the Fairchild compressor, custom-designed heat exchangers, commercial TXV, and commercial VFD, as well as system integration and packaging.

Future optional phases of this program include:

1. **Prototype Fabrication:** A prototype heat pump with a “basic” controller will be fabricated to verify the detailed design. The system will integrate the commercial VFD with the Fairchild compressor. The gravity-insensitive heat exchangers and control valve designed and selected in the base contract will be fabricated and procured, respectively. An ITCS and ETCS thermal loop will be fabricated for breadboard testing. The ITCS and ETCS water loops will be designed for nominal flow rates (in gpm) of 2.4x and 3.0x the heat pump capacity (in tonR) per ASHRAE standards for liquid-to-liquid heat pump systems. The flow loops will be variable capacity to validate the effect of flow rate on heat pump performance.
2. **Advanced System Development:** The “basic” control system will be upgraded to allow for solar power operation. Control and power system upgrades and liquid system upgrades associated with direct exchange of heat in heat pump “off” or “night” mode will also be performed. The heat pump will be able to automatically and smoothly transition to rejecting the ITCS heat load directly to the ETCS loop without loss of setpoint control, operate using a solar photovoltaic (PV) power source, operate at reduced capacity on a cloudy day with the PV array, be remotely computer controlled, and provide output data for “flight instrumentation” and “engineering data” data acquisition systems.
3. **Flight Readiness Assessment:** The prototype gravity-insensitive heat pump will be assessed for flight readiness aboard a NASA C-9B and future space missions. The assessment will include each hardware and software component of the heat pump and be based on vendor data and specifications. Recommendations will be made as to which components are ready for the flight certification phase and which components require additional development.

The result of the overall program, including optional phases, will be a gravity-insensitive heat pump with a Technology Readiness Level (TRL) of 6, “System/subsystem model or prototype demonstration in a relevant environment.” The representative prototype system will be well beyond that of TRL 5 (component and/or breadboard validation) and will be tested in a relevant environment, i.e., simulated microgravity. TRL 6 represents a major step up in the demonstrated readiness of a technology.

CONCLUSIONS

This paper presents the performance specifications and preliminary assessment for development of a gravity-insensitive heat pump for future microgravity and lunar applications. Detailed discussion of component selection and technical hurdles for microgravity operation are included. Future plans include prototype fabrication, advanced system development, and flight readiness assessment. This is the first of several papers that will document the development life cycle of the gravity-insensitive heat pump.

ACKNOWLEDGMENTS

The authors gratefully acknowledge NASA JSC for financial support of this research and development.

REFERENCES

Ewert, M. K., “Investigation of Lunar Base Thermal Control System Options,” Paper no. 932112 at the SAE 23rd International Conference on Environmental Systems in Colorado Springs, CO, July 12–15, 1993.

Ewert, M. K., "Terrestrial and Aerospace Solar Heat Pump Development: Past, Present and Future," ASME, Solar 98, 1998.

Ewert, M. K., Keller, J. R., and Hughes, B., "Conceptual Design of a Solar Powered Heat Pump for Lunar Base Thermal Control Systems," SAE paper #961535, International Conference on Environmental Systems, 1996.

Ewert, M. K., et al., "Experimental Evaluation of a Solar PV Refrigerator with Thermoelectrics, Stirling, and Vapor Compression Heat Pumps," Proceedings of Solar 98, American Solar Energy Society, Albuquerque, New Mexico, June 1998.

Ewert, M. K., and Bergeron, D. J., "Development of a Battery-Free Solar Refrigerator," ISES Millennium Solar Forum 2000, paper #DSSA 10-03, Mexico City, 2000.

Grzyll, L. R., "Active Thermal Control Systems for Space Applications: A Trade Study," presented at the 11th Spacecraft Thermal Control Technology Workshop, El Segundo, CA, March 2000.

Grzyll, L. R., and Cole, G. S., "A Prototype Oil-Less Compressor for the International Space Station Refrigerated Centrifuge," Proceedings of the 2000 International Compressor Engineering Conference at Purdue — Volume I, 121–8, 2000.

Grzyll, L. R., et al., "Development and Testing of a Prototype Low-Lift Heat Pump for Spacecraft Thermal Control," Proceedings of the Space Technology and Applications International Forum — 2001, 271–6, 2001.

Grzyll, L. R., "Demonstration of a Low-Lift Heat Pump for High-Power Spacecraft Thermal Control," 2006 Space Technology and Applications International Forum (STAIF-2006), Albuquerque, NM, February 2006.

Morton, R., Bergeron, D., Hurlbert, K., Ewert, M., Cornwell, J., "Proof of Concept High-Lift Heat Pump for a Lunar Base," SAE paper #981683, International Conference on Environmental Systems, 1998.

NASA JSC, Request for Quotation NNJ06147523Q, April 6, 2006.

Paul, T.H., "Compressors Suitable for Space-based Heat Pumps," Lockheed Martin Space Operations, TWP: MHECECAEX, MSAD-04-0092, January 9, 2004.