

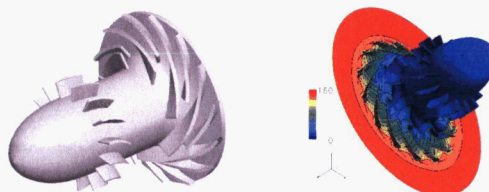

DESIGN AND ANALYSIS OF A TURBOPUMP FOR A CONCEPTUAL EXPANDER CYCLE UPPER-STAGE ENGINE



D. Dorney, J. Rothermel, L. Griffin, R. Thornton, J. Forbes, S. Skelley
NASA Marshall Space Flight Center
MSFC, AL

F. Huber
Riverbend Design Services
Palm Beach Garden, FL

Symposium on Advances in Numerical Modeling of Aerodynamics and Hydrodynamics in Turbomachinery



Outline

- **Motivation**
- **Numerical method**
- **Numerical simulations**
 - vaneless diffuser
 - vaned diffuser
- **Conclusions**

Symposium on Advances in Numerical Modeling of Aerodynamics and Hydrodynamics in Turbomachinery

Motivation



- **Develop technologies to be applied to CLV/CEV engine programs**
 - analytical tools → 1D meanline analysis and 3D CFD
 - mechanical design
 - water flow tests
- **Design a conceptual expander-cycle upper stage engine**
- **Demonstrate the design using water flow testing**

Symposium on Advances in Numerical Modeling of Aerodynamics and Hydrodynamics in Turbomachinery

Numerical Methods - I



- **Meanline analysis and geometry generation**
- **Pump Design**
 - Concepts NREC design suite
 - Agile Engineering Design System©, PUMPAL©, CCAD©
- **Diffuser design**
 - Riverbend Design Services pump design code

Symposium on Advances in Numerical Modeling of Aerodynamics and Hydrodynamics in Turbomachinery

Numerical Methods - II



- **PHANTOM CFD code**
- **Three-dimensional, unsteady N-S equations**
- **Generalized Equation Set formulation**
 - Handles liquids and gases
 - Incompressible, compressible and supersonic flow
 - Preconditioning for incompressible flows
- **Implicit, time marching, finite difference scheme**
- **3rd order spatially, 2nd order temporally accurate**
- **Modified Baldwin-Lomax turbulence model**
- **Overlaid O- and H-grids**

Symposium on Advances in Numerical Modeling of Aerodynamics and Hydrodynamics in Turbomachinery

Numerical Methods - III



- **MPI for parallel simulations**
- **Fluid property routines**
 - Perfect gas
 - Real fluid property routines for xenon, N₂, H₂, H₂O, O₂, RP, CH₄, CO, N₂H₄, MMH and N₂O₄
 - Two types of real fluid property routines
 - **Routines provided by J. Oefelein of Sandia Labs – liquid and gas**
 - Solve equations of state, etc.
 - **Routines derived from the NIST tables – liquid and gas**
 - Surfaces generated from splines of data

Symposium on Advances in Numerical Modeling of Aerodynamics and Hydrodynamics in Turbomachinery

Design Requirements for Water Flow Rig



- Operate in existing water flow facility
- 977 gpm flow rate
- Rotational speed of 3600 RPM
- 70% flow coefficient throttling capability
- Diffuser vane/volute radius and passage constraints due to rig requirements
 - vanes must accommodate 17 bolts
- Actual engine was designed to have two stages, but the water flow model designed to have one stage

Symposium on Advances in Numerical Modeling of Aerodynamics and Hydrodynamics in Turbomachinery

Guide Vane and Impeller Design

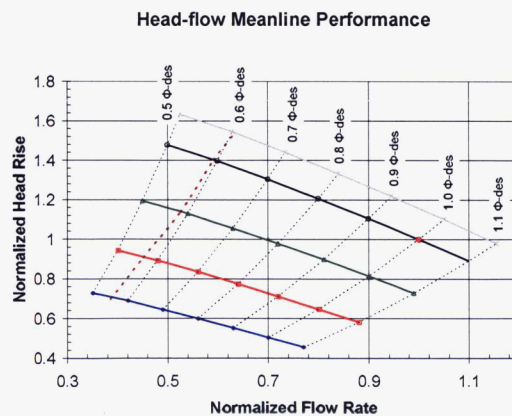
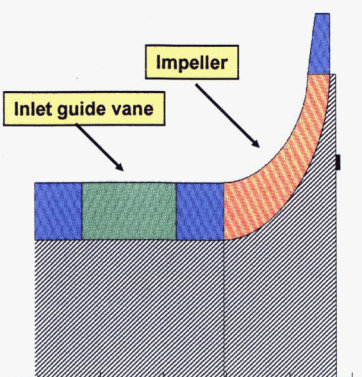

Symposium on Advances in Numerical Modeling of Aerodynamics and Hydrodynamics in Turbomachinery

Guide Vane and Impeller Design



Mean Streamtube Analysis

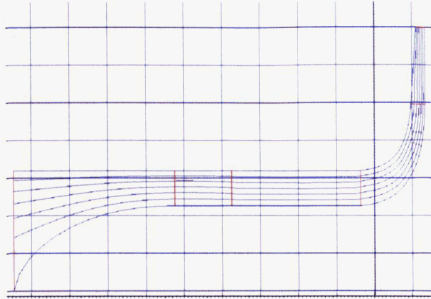

Streamlines

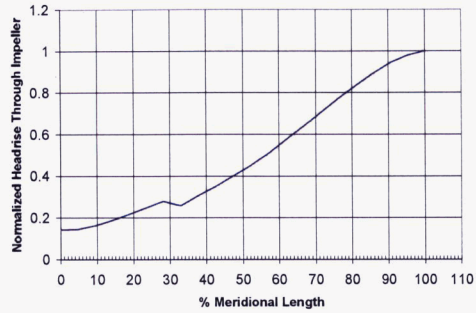

Impeller pressure rise

Symposium on Advances in Numerical Modeling of Aerodynamics and Hydrodynamics in Turbomachinery

Guide Vane and Impeller Design

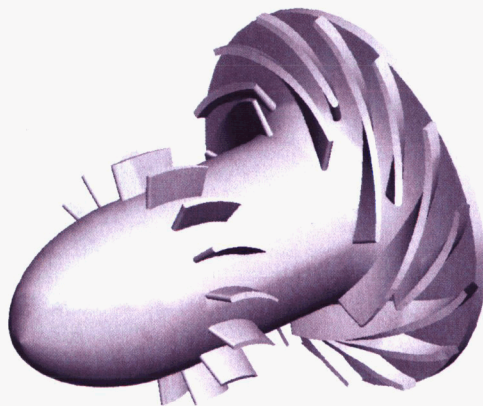

Final Pump Design

1. 15 inlet guide vanes
2. Impeller with 7 main blades and 7 splitter blades

Symposium on Advances in Numerical Modeling of Aerodynamics and Hydrodynamics in Turbomachinery

CFD for IGV, Impeller, Vaneless Diffuser

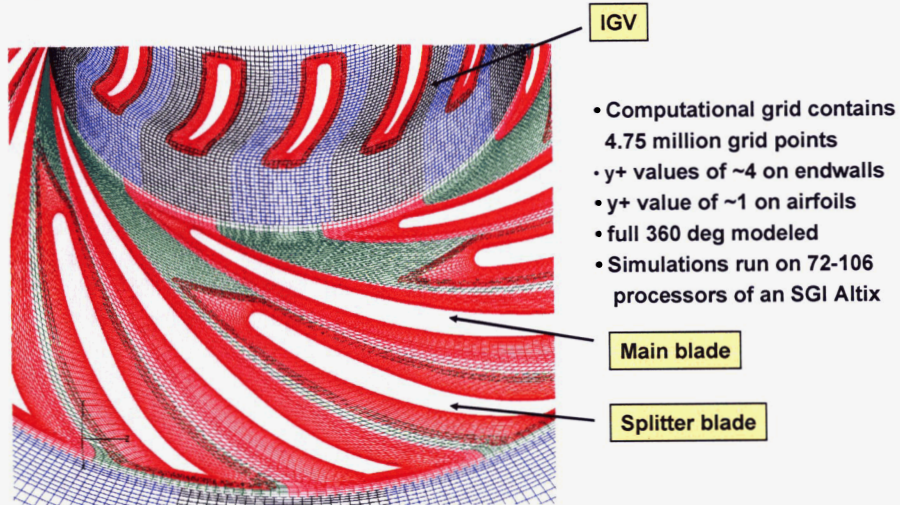

Symposium on Advances in Numerical Modeling of Aerodynamics and Hydrodynamics in Turbomachinery

CFD for IGV, Impeller, Vaneless Diffuser

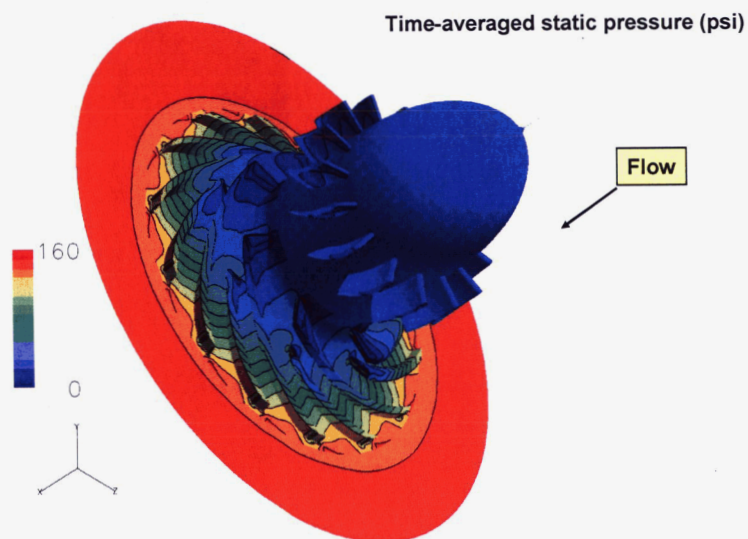

Symposium on Advances in Numerical Modeling of Aerodynamics and Hydrodynamics in Turbomachinery

CFD for IGV, Impeller, Vaneless Diffuser



Relative total pressure (psi)

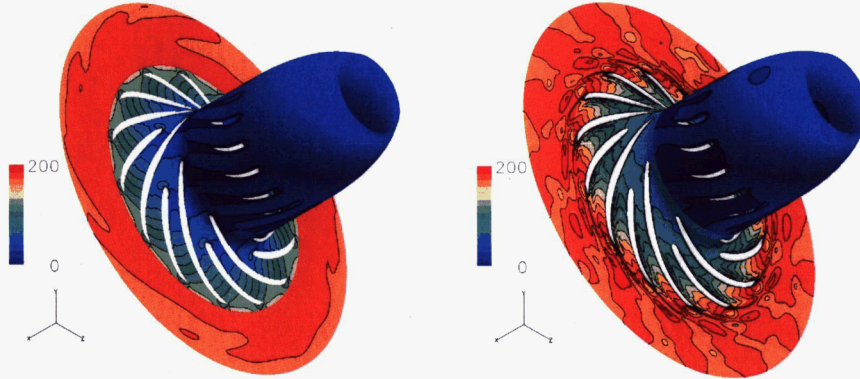

Time-averaged

Instantaneous

Symposium on Advances in Numerical Modeling of Aerodynamics and Hydrodynamics in Turbomachinery

CFD for IGV, Impeller, Diffuser



Performance predicted by meanline and CFD codes

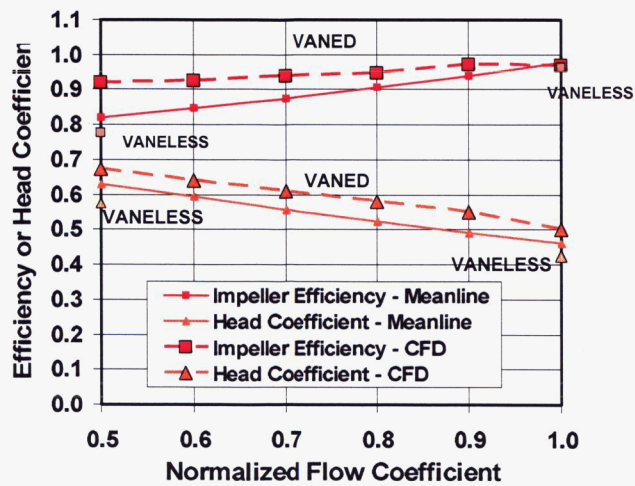

Symposium on Advances in Numerical Modeling of Aerodynamics and Hydrodynamics in Turbomachinery

CFD for IGV, Impeller, Vaneless Diffuser

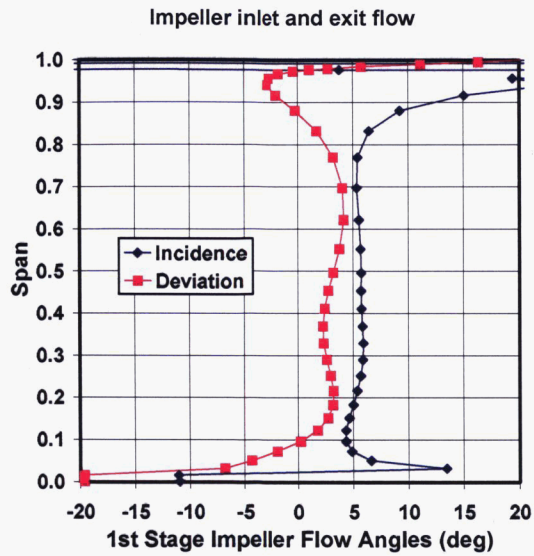

Symposium on Advances in Numerical Modeling of Aerodynamics and Hydrodynamics in Turbomachinery

CFD for IGV, Impeller, Vaned Diffuser

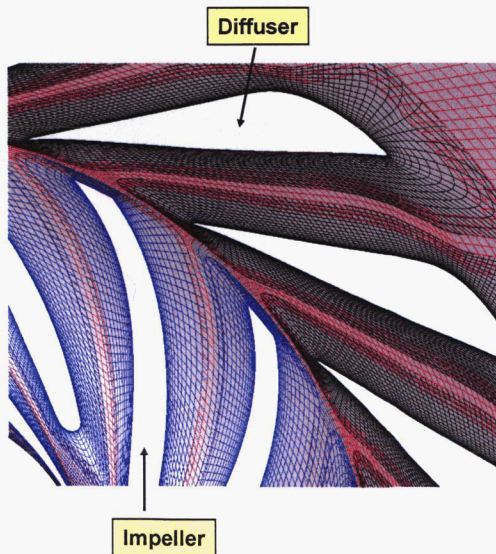

Variable	Optimum	Actual
L/W_1	4.00	2.60
W_2/W_1	1.60	1.34
θ (deg)	10.0	7.40

- 17 diffuser vanes
- chord of vane limited by collector

Symposium on Advances in Numerical Modeling of Aerodynamics and Hydrodynamics in Turbomachinery

CFD for IGV, Impeller, Vaned Diffuser



Time-averaged loading on the impeller and diffuser

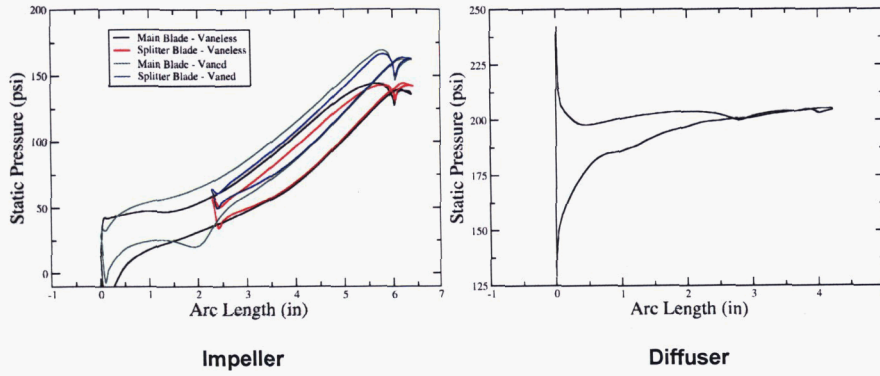

Symposium on Advances in Numerical Modeling of Aerodynamics and Hydrodynamics in Turbomachinery

CFD for IGV, Impeller, Vaned Diffuser



Unsteadiness on the impeller trailing edge with downstream diffuser vanes

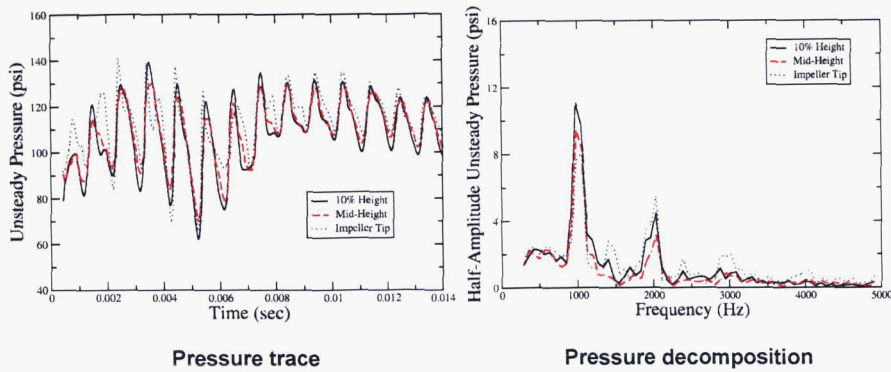

Vane passing frequency = 1020 Hz

Symposium on Advances in Numerical Modeling of Aerodynamics and Hydrodynamics in Turbomachinery

CFD for IGV, Impeller, Vaned Diffuser



Unsteadiness on the diffuser leading edge with the upstream impeller

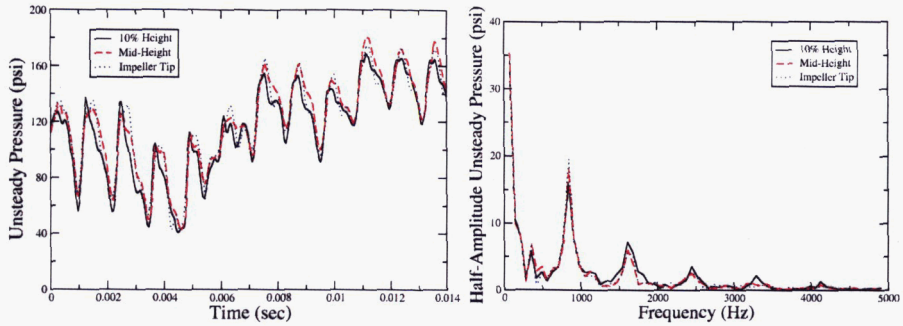

Pressure trace

Pressure decomposition

Blade passing frequency = 840 Hz

Symposium on Advances in Numerical Modeling of Aerodynamics and Hydrodynamics in Turbomachinery

Water Flow Tests

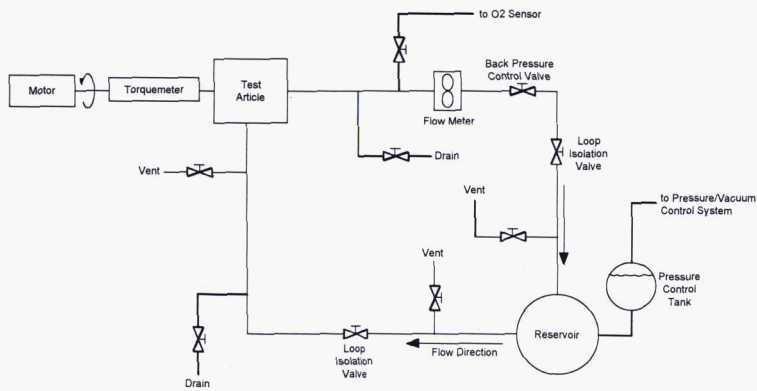

Design to be tested in MSFC water flow facility late summer 2006

Symposium on Advances in Numerical Modeling of Aerodynamics and Hydrodynamics in Turbomachinery

Conclusions



- Inlet guide vane, impeller and diffuser designed for a conceptual expander cycle upper stage engine
- Meanline analysis and three-dimensional unsteady CFD show that the design meets the requirements and constraints
- Water flow testing of the design should begin late summer 2006

Symposium on Advances in Numerical Modeling of Aerodynamics and Hydrodynamics in Turbomachinery