

Development of Point Doppler Velocimetry for Flow Field Investigations

Angelo A. Cavone¹, James F. Meyers², Joseph W. Lee³

1: Swales Aerospace, NASA Langley Research Center, Hampton, Virginia 23681, United States

A.A.Cavone@larc.nasa.gov

2: Distinguished Research Associate of NASA Langley Research Center, Hampton, Virginia 23681, United States

james.f.meyers@larc.nasa.gov

3: NASA Langley Research Center, Hampton, Virginia, 23681, United States

joseph.w.lee@nasa.gov

Abstract A Point Doppler Velocimeter (pDv) has been developed using a vapor-limited iodine cell as the sensing medium. The iodine cell is utilized to directly measure the Doppler shift frequency of laser light scattered from submicron particles suspended within a fluid flow. The measured Doppler shift can then be used to compute the velocity of the particles, and hence the fluid. Since this approach does not require resolution of scattered light from individual particles, the potential exists to obtain temporally continuous signals that could be uniformly sampled in the manner as a hot wire anemometer. This leads to the possibility of obtaining flow turbulence power spectra without the limitations of fringe-type laser velocimetry. The development program consisted of a methodical investigation of the technology coupled with the solution of practical engineering problems to produce a usable measurement system. The paper outlines this development along with the evaluation of the resulting system as compared to primary standards and other measurement technologies.

1. Introduction

Over the last 16 years, a new generation of laser-based diagnostic instruments based on the research of Komine, *et. al* (1991) have been introduced to the fluid mechanics research community. These techniques employ molecular iodine absorption filters as light frequency discriminators enabling flow fields to be characterized in a non-intrusive manner. To date several variations of the Doppler Global Velocimeter (DGV) (or Planar Doppler Velocimeter (PDV)) have been developed to characterize the movement of flow embedded particles. Taking advantage of the optical frequency shift observed when light is scattered by moving particles due to the Doppler effect, this technique exploits the light frequency-to-light absorption transfer function of iodine vapor to measure the directional velocity of particles passing through a single-frequency laser light sheet. The application of lessons learned and methodologies developed during DGV research has resulted in a spin-off technique referred to as point Doppler velocimetry (pDv).

pDv trades the spatial capabilities of DGV to make planar velocity measurements for the ability to make temporally continuous velocity measurements at a point by using photomultipliers in place of video cameras and a focused laser beam in place of a light sheet. This offers advantages over the more matured fringe-type Laser Doppler Velocimeter (LDV) because pDv measurements are obtained by detecting optical frequency variations in overall scattered light levels. Thus, the requirement of LDV to detect single particle passages through the sample volume is overcome. Consequently, smaller scattering particulates can be used eliminating concerns related to particle lag. The potential to make continuous velocity measurements overcomes the Poisson random sampling of LDV, the low frame rates of cameras used in DGV, and possibly improves the accuracy of temporal statistical measurements beyond that of LDV.

With sufficient scattering particles pDv offers the potential to make flow frequency measurements that are as accurate as those of hot-wire anemometry. In addition pDv measurements can be expanded to perform spatial cross correlations by replacing the single detector with a linear array and imaging a

portion of the laser beam onto the array. The non-intrusive nature of pDv removes two limitations of the hot-wire which; (a) disturbs the investigated flow and (b) are not capable of measuring reverse flows. This offers the potential for improvements over hot-wire spatial cross correlation measurements which must be taken in a manner that insures that the wake of one probe does not influence the second probe.

2. Background

Non-intrusive, laser-based flow instruments are attractive to aerodynamicists since they do not disturb the flow. Further, global flow mapping techniques such as Particle Image Velocimetry (PIV) yield instantaneous flow maps and reduce facility run times and costs. Alternatively, Komine *et. al* (1991) proposed using molecular absorption filters together with video cameras to globally map velocity flow fields. Their DGV system overcame the requirement of fringe-based laser velocimetry and PIV to resolve single particle passages and increased the field of view over what PIV was capable of at that time.

Since the time of Komine's original work, a number of organizations have worked diligently to develop DGV systems that have proven to be reliable and robust enough to meet the demands of production flow research facilities. Several variations of DGV systems employing molecular iodine as an absorption medium have been developed that use either Argon-Ion or frequency doubled Nd:YAG

lasers to illuminate particle laden flows. The geometry used in most of these systems is presented in Fig. 1.

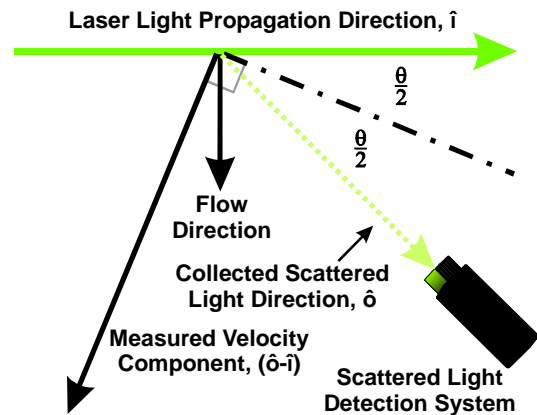

Fig. 1 DGV velocity measurement geometry.

In this arrangement, the Doppler frequency and hence the velocity component measured is dependent on the location of the laser light sheet with respect to the receiving optical system. The component of velocity measured, $\hat{o} - \hat{i}$, is the vector perpendicular to the bisector of the unit vector of the collected scattered light, \hat{o} , and the propagation direction of the input laser light, \hat{i} . For a given flow velocity vector V , the collected scattered laser light frequency shift, $\Delta\nu$, is dependent on the dot product between the velocity vector V , and the measurement vector $\hat{o} - \hat{i}$,

(Equation 1), (Meyers, Komine (1991)), where c represents the speed of light and ν_o represents the laser light frequency. Thus, multiple detector systems and/or light sheets have been used to measure additional, non-orthogonal, velocity components. These non-orthogonal components can then be translated into standard orthogonal u , v , and w velocity components.

$$\Delta\nu = \frac{\nu_o(\hat{o} - \hat{i}) \cdot V}{c} \quad [1]$$

Fig. 2 is a representative DGV system in which the absorption characteristics of iodine vapor acts as an optical frequency discriminator on the scattered laser light produced when particles pass through the illuminated region. The optical frequency difference between the output of a either a single-frequency Argon ion or frequency doubled Nd:YAG laser and the collected scattered light is the Doppler frequency induced by the motion of the particles. The light-frequency dependent optical

transmission of the IVC (Fig.3) converts the change in light frequency to a change in transmitted light intensity, which can be measured using photodetectors. Calibration tables relating light absorption versus optical frequency are required for each unique IVC, as the absorption characteristics of each cell will differ based on the internal vapor pressure. The effect of the iodine transfer function on the collected light is obtained by using two cameras in the measurement component - one sampling the collected light before the cell (reference) and one sampling the light after the cell (signal). The reference camera accounts for variations in scattered light intensity due to inconsistencies in laser power and particle number density. Normalizing the intensity level at the signal camera by the intensity level at the reference camera yields a signal that is dependent only on the optical frequency of the scattered light. The laser frequency, measured at the Laser Frequency Monitor (LFM) (Fig. 2), is then subtracted from the DGV-measured frequency image to yield a Doppler frequency image.

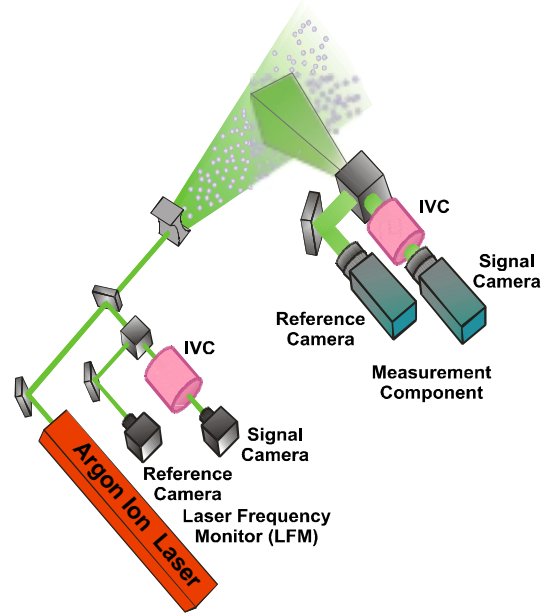

Fig. 2 DGV measurement geometry.

Recognizing the potential of using molecular filters to obtain continuous velocity measurements at a point, and improving upon the fringe-type LV technique, Hoffenberg and Sullivan (1993) developed a point measurement system. They employed a Cesium-vapor Faraday cell as a frequency discriminator and replaced the cameras used in DGV with photodiodes. The pDv velocity measurements they obtained for a turbulent jet compared favorably to within 2-percent of LV measurements for the same flow conditions. This work was continued at the West Virginia University where a two-component pDv system employing iodine vapor as the frequency discriminator was developed by Kuhlman and Scarberry (2002). Their system provided velocity measurements of a rotating wheel to an accuracy of ± 0.5 m/sec. They also obtained velocity measurements of the flow exiting a one-inch diameter pipe flow that were within ± 3 m/sec of average pitot probe and hot-wire anemometer velocity measurements. In addition, pDv spectral measurements were attempted and the resultant spectral plots were similar to the shape produced using hot-wire samples; however, no quantitative comparisons were presented. These research efforts identified three fundamental limitations in the pDv technique: (a) a high particle number density was required to obtain continuous velocity measurements, (b) laser frequency instability compromised system measurement accuracy, and, (c) without precise calibrations of the transfer function of the IVCs, accurate velocity measurements were not feasible.

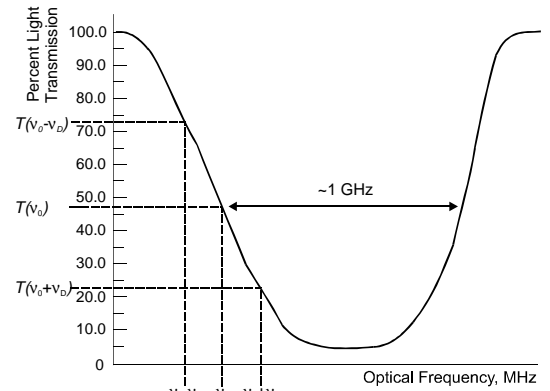

Fig. 3 IVC transfer function.

3. pDv Instrument Research

Presently, a pDv system is being developed at NASA Langley Research Center. Based on the design of Kuhlman, *et al* (1997), this system uses molecular iodine as the light frequency-sensing medium. Iodine vapor was selected over Cesium vapor to overcome limitations of lasers that are capable of operating near the 850-nm Cesium resonance; laser diodes and Alexandrite lasers. The low output power levels of laser diodes limits their application to high scattering particle situations while the high cost, complexity, instability, and large physical size of the Alexandrite laser makes it undesirable for use as the pDv light source.

The goal of the present research was to investigate the capabilities of the pDv technology and address limitations identified in previous research in order to produce an instrument capable of providing accurate/reliable velocity and turbulence spectra measurements in flow research facilities (Cavone (2005)).

3.1 pDv Instrument Configuration

The schematic of the optical system employed in the presented research is depicted in Fig. 4. While this configuration is similar to that used in DGV, the cameras in the measurement component

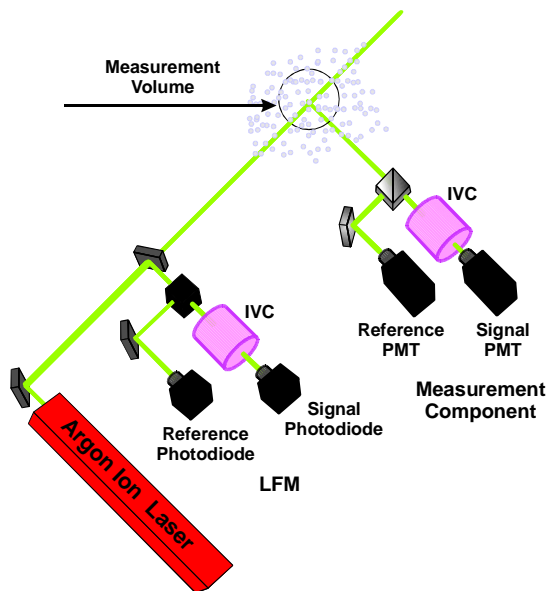

Fig. 4 Schematic of the Point Doppler Velocimeter.

have been replaced with photodetectors to increase system bandwidth. Based on the work of Kuhlman and Scarberry (2002) Avalanche Photodiodes (APDs) were initially used in the system and operated in non-Avalanche mode where they produced a linear output signal. Although the APDs produced usable signals in the laboratory setting, it was determined that when operated in the linear mode they did not possess the sensitivity required to detect particle scattered light variations in wind tunnel configurations. The APDs were subsequently replaced with fast response, high gain, photomultiplier (PMT) modules which had the sensitivity needed for the low particle-scattered light levels encountered in pDv.

Standard PIN photodiodes were used to monitor laser frequency in the LFM. The two iodine vapor cells were constructed in the manner proposed by Elliot, *et. al*, (1994) and based on theory proposed by Forkey (1996). The IVCs were constructed to be

vapor-limited at 40° C and operated at 60° C where the resident iodine was kept in a vapor state and the greatest dynamic transmission range for the iodine absorption line was realized, Forkey (1996).

An Argon Ion laser operating in single frequency mode was used as the illumination source. From Equation [1], stable, single frequency operation is paramount to the accurate resolution of the Doppler frequency shift in light resulting from particle motion. Accordingly, short-term laser frequency fluctuations were tracked by sampling the LFM in parallel with the acquisition of each velocity data point. Prior to acquiring each pDv data record, the laser was frequency tuned by mechanically changing the tilt angle of the etalon installed in the laser cavity. This enabled the selection of a single

longitudinal mode where the scattered light frequency measurements could be made within the linear region of the intensity-to-frequency transfer function of the IVC.

The data acquisition and processing hardware system was constructed with both commercial and custom hardware subsystems. Control, management and monitoring of the various data acquisition and processing activities was accomplished using PC class computers which hosted analog data acquisition, system-timing control, and GPIB interface boards. The analog data acquisition board was capable of digitizing eight analog input signals at rates of up to 250 kHz to a resolution of 12-bits. The system-timing controller with an 80 MHz time base synchronized the operation of the various hardware components. The GPIB interface controlled a scan-rig that provided positioning of the pDv sample volume anywhere within a ten-inch cube. A Graphical User Interface (GUI), written using the National Instruments LabVIEW programming platform facilitated the control of system hardware components and the acquisition, processing, archival, and presentation of data records.

3.2 pDv Data Reduction

Conversion of the photomultiplier output signals to velocity was performed through a series of adjustments and processes. These include the removal of background light levels, data scaling to match system characteristics with the IVC calibration (flat-field), and normalizing the signal level by the reference level. The corrected ratio was then converted to optical frequency, then Doppler frequency and finally velocity.

Light detected by the PMTs can originate from several sources: (a) laser light scattering from particles passing through the measurement volume, (b) laser light scattering from particles passing through the laser beam which then scatters again from other objects, (c) laser light scattering from objects outside the measurement volume, and, (d) extraneous light from room lights, etc. The last two items make up undesired background light sources. These levels may be determined by acquiring data sets under normal facility run conditions before the particles are injected into the flow. Since the photodetectors are linear, the background can be removed through simple subtraction. This process must be repeated for all measurement locations where the background levels may change. The test configuration should be designed to minimize secondary scattering as these effects cannot be removed and becomes a source of measurement error.

The flat field calibration is the *scale factor* that accounts for unique differences in the optical, detector and signal conditioning paths between the pDv and the characteristics of the IVC calibration. In summary the flat field calibration aligns the measurement data to the normalized iodine calibration data. Data sets were collected with the laser tuned to place the Doppler shifted light outside of the iodine absorption line to negate any optical frequency-dependent absorption effects. Signal and reference detector output signals were sampled with the same particle seeding used to make velocity measurements. Reference detector samples were normalized by signal detector samples after background levels were subtracted and the results averaged to establish flat field correction factors unique to both the measurement and LFM components. The conversion of the detector output signals to measurement ratios is given in Equation 2 where the appropriate background levels are subtracted from the flat field and data levels respectively, ratios calculated, and the data ratio scaled:

$$N[i] = \left(\left[\frac{S[i] - BG_S}{R[i] - BG_R} \right] * \left[\frac{FF_R - BG_{RFF}}{FF_S - BG_{SFF}} \right] \right) * 2048 \quad [2]$$

where $N[i]$ is the i^{th} corrected and scaled ratio measurement and $S[i]$ and $R[i]$ the measured signal and reference levels respectively. The variables BG and FF are the background levels and flat field correction factors for the signal and reference (S , R) images and flat field images (SFF , RFF), respectively.

Scaled normalized values provided an address to a 2048 element lookup table describing the frequency-to-light absorption transfer functions of the IVCs. A linear interpolation algorithm between adjacent normalized values extracted from the lookup table was used to compute optical frequency. The i^{th} laser frequency obtained from the LFM, $\nu_{LFM}[i]$, was then subtracted from that of the measurement component, $\nu_{MC}[i]$, to determine the Doppler frequency shift, $\Delta\nu[i]$, resulting from the particle motion:

$$\Delta\nu[i] = \nu_{MC}[i] - \nu_{LFM}[i] \quad [3]$$

In the manner of Equation 1, the velocity vector for the system geometry and the Argon Ion laser wavelength (514.5nm) were applied to determine the velocity of each independent sample:

$$V[i] = \frac{\Delta\nu[i] * \lambda}{(\hat{o} - \hat{i})} \quad [4]$$

where $V[i]$ is the i^{th} measured component velocity and λ is the wavelength of the laser light.

4. Iodine Vapor Cell Calibration

The first phase in the research was concerned with developing accurate calibrations of the light attenuation-to-frequency (A/F) transfer functions of the system IVCs. This was a prerequisite since

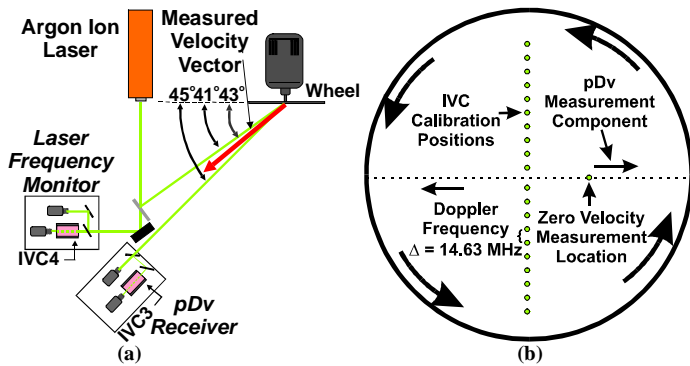

Fig. 5 (a) Geometry and (b) rotating wheel used for IVC calibrations.

two major error sources are related to the consistency and accuracy of the calibrations established for the true absorption profile of an IVC (Meyers and Lee (2000)). Because it was difficult to directly measure the absolute frequency of the laser, an alternative method was employed to develop calibrations of the A/F transfer functions for the IVCs. A 305-mm diameter rotating wheel, arranged as shown in Fig. 5(a), induced a known Doppler shift in the frequency of the scattered laser light. In this geometric configuration, the measured velocity vector was in the horizontal plane.

By adjusting the laser to different frequency modes and scanning the laser beam vertically across the wheel surface in evenly spaced, 12.7 mm increments, a calibration of the left-hand side of the selected absorption line was obtained. Since the span of the Doppler shift frequency was larger than the longitudinal mode spacing of the laser the absorption line profile could be determined in a piecewise manner. The collection of individual absorption profile segments, were post-processed using custom sorting and interleaving software algorithms. The range of frequencies induced by the wheel rotation

provided sufficient frequency overlap between adjacent modes to accurately align the segments. This process produced a calibration curve that had a shape resembling the expected profile. However, a close examination of the calibration data sets showed that in some areas, even after using rms error minimization, the fit between adjacent points was not smooth and demonstrated jitter in excess of acceptable levels (Fig. 6(a)). This was because the overlapped regions of adjacent segments did not always have similar slopes, and/or the spacing between individual points was not uniform. It was determined that these variations were caused by laser frequency drift that occurred during data collection. The resulting segment alignment jitter produced multiple frequency values for a given ratio, which if left uncorrected would make unique optical frequency determination impossible. To minimize the effects of the segment alignment jitter and improve the calibrations a B-Spline curve fit was applied, Fig. 6(b). In addition calibrations developed for the IVCs were adjusted to overcome a frequency offset caused by differences in iodine vapor pressures for each cell and to a lesser extent, variations in the longitudinal frequency mode positions resulting from laser cavity length changes.

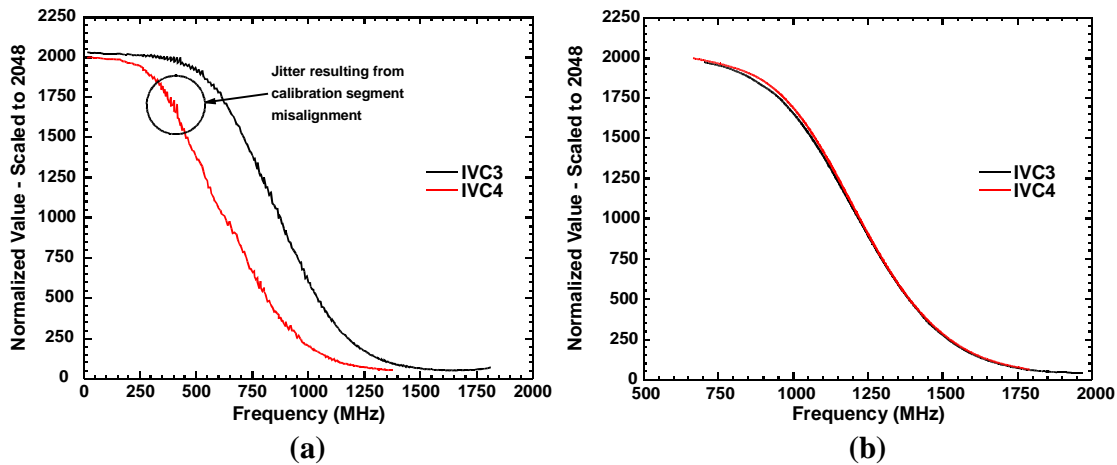

Fig. 6 IVC calibrations, (a) initial, (b) final after B-Spline fit and frequency adjustments.

5. Experimental Results

5.1 Rotating Wheel Velocity Measurements

The developed calibration profiles, which approximated the true frequency response of the IVC, were verified by measuring the velocity profile along the vertical diameter of a rotating wheel. Data sets were acquired at a wheel speed of 2400 rpm. The measurement volume was scanned 254 mm across the surface of the wheel starting 25.4 mm from its edge in 12.7 mm increments. At each position, 4096 sample records were acquired at 5 kHz with the wheel speed being recorded in parallel with each sample. Average pDv resolved velocities were within ± 1 m/s of computed wheel velocities (Fig. 7).

5.2 pDv Air Flow Measurement Investigations

The ability of pDv to provide air flow measurements was investigated by configuring the system to measure the flow exiting a 50.8-mm diameter pipe (Fig. 8). This flow was driven by a 270-mm diameter, six-bladed blower operating at 3550 RPM (Fig. 9). Mineral oil smoke particles from a

commercial smoke generator were drawn into the blower to seed the flow. System performance was evaluated for statistical and temporal measurement accuracy and repeatability. The results were

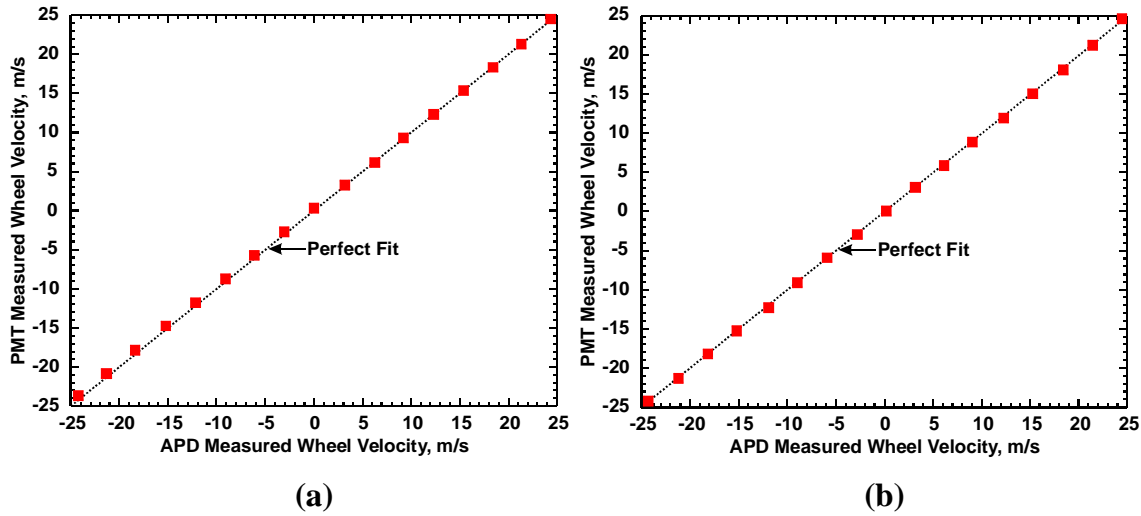

Fig. 7 Vertical velocity profile of a rotating wheel measured using pDv, (a) center mode, and (b) one mode below center laser frequency settings.

compared to those obtained using two flow measurement standards - a pitot probe (average velocity) and a hot-wire anemometer (statistics and temporal) for the same flow conditions. Average velocity measurements were simultaneously obtained using pDv and a pitot probe located 3.0 mm downstream of the pDv measurement volume.

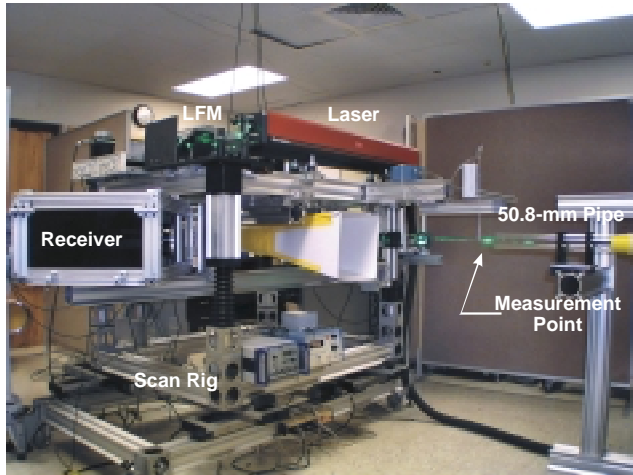

Fig. 8 Photograph of the pDv system installed in the 50.8-mm pipe facility

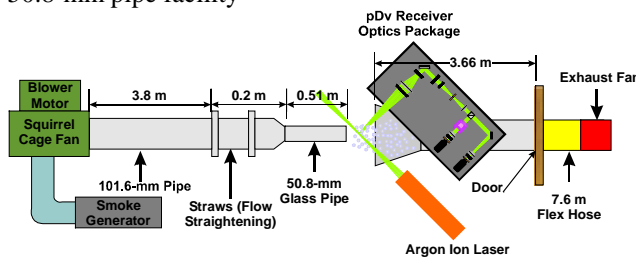

Fig. 9 Schematic of the 50.8-mm pipe flow used to investigate pDv capabilities.

This separation distance was necessary so that the presence of the probe would not influence the flow at the pDv measurement location (>2 probe diameters upstream). The pDv configuration produces a spherical measurement volume approximately 2-mm in diameter and measures the streamwise velocity component. Horizontal velocity profiles were acquired at x/D locations of 0, 0.125, 0.250, 0.50, 1.00, 2.00 and 4.00 downstream of the pipe exit. Data collection at these stations began at the pipe centerline axis and proceeded to the right of the pipe exit (facing downstream) in $r/R = 0.10$ (2.54 mm) increments. The sequence was repeated in the left-hand direction after the sample volume scanned to flow centerline ($r/R = 0$). This manner of scanning the probe volume was followed in all subsequent testing. With the pDv system was arranged in the geometry of Fig. 1, the symmetric orientation of the pDv receiver and the laser about the flow centerline yielded a direct measure of the streamwise velocity (u -component).

The results of the initial simultaneous pDv

and pitot probe test conducted at the $x/D = 2$ downstream station are presented in Fig. 10. pDv velocity measurements were in good agreement with the pitot measurements in shape and the developed turbulence intensity profile was typical of this type of flow. Notice however, the significant drop off in the average pDv velocity measurements during the time between the acquisitions of the first and second data points at the flow centerline. In addition, velocities measured at several positions left of centerline did not agree with symmetric velocity measurements made to the right of centerline. Because the pitot probe measurements did not demonstrate a velocity change, it confirmed that the flow was stable over time indicating a problem with the pDv measurements.

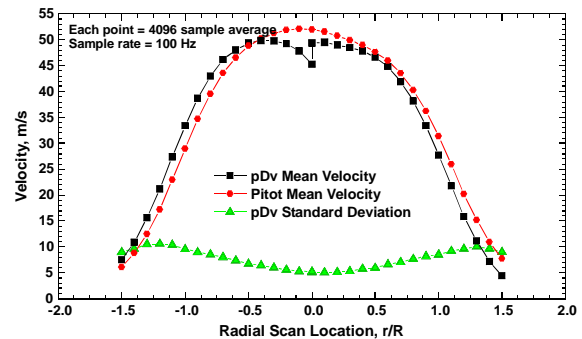

Fig. 10 First pDv velocity and turbulence intensity two-inch pipe measurements at $x/D=2$.

Inspection of the LFM measurements showed that the laser frequency drifted ~ 80 MHz during the time it took to survey the velocity profile to the right of pipe exit. This drift resulted in different regions of the IVC calibration curves being used to resolve Doppler frequency shifts over the course of the profile scan. This reinforced earlier predictions that the two primary error sources are: (a) maintaining the laser at a single frequency, and, (b) IVC calibration accuracy.

Additional pDv data sets that were acquired yielded similar results and provided more insight into the cause of the observed behavior. This information confirmed that laser frequency drift would have to be minimized before accurate measurements could be obtained. To keep the development of the pDv technique on track, a short-term solution used was to closely monitor laser frequency and manually adjust it as needed. Before acquiring each data record, the laser frequency was confirmed and as required tuned back to approximate the same frequency mode position used at the beginning of a test sequence.

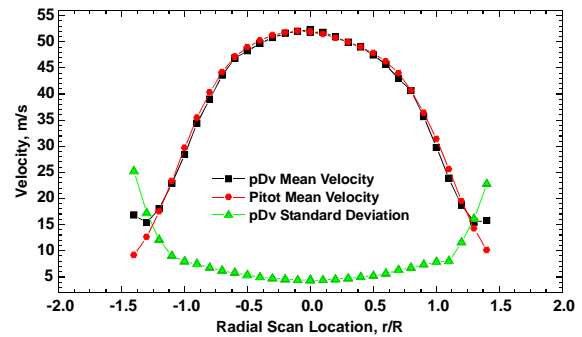

Fig. 11 Horizontal plane velocity profiles measured at $x/D = 2$ station after manual laser tuning.

Whenever the laser frequency drifted significantly during the acquisition of a given data record, that record was deleted and the data was reacquired. This mode of operation enabled nearly the same region of the iodine absorption profile to be used for Doppler frequency determination resulting in pDv velocity measurements that were in excellent agreement with those of the pitot probe (Fig. 11). Also, since the standard deviation level was about 5% in the core region, it was concluded that the pDv resolved velocities were reasonable since they were comparable to LDV and hot wire measurements obtained in a similar flow (Meyers and Wilkinson (1982)).

Although manual tracking/controlling of the laser frequency provided good measurements, the results obtained during additional testing still demonstrated flow measurement errors since different regions of the IVC calibrations were being used over time for Doppler frequency resolution. A close examination of the data points taken at flow centerline confirms the presence of laser frequency drift. After contemplating the procedures followed to obtain accurate pDv measurements, it was decided that an active method of controlling laser frequency would simplify system operations and provide results that were more consistent. This was addressed by incorporating the laser drift minimization system developed by Lee and Meyers (2005) (Fig. 12), and boxcar integrators which were installed at the

output of each PMT. The boxcar integrator acts as a wide bandwidth low-pass filter by integrating real-time signals (200 MHz bandwidth) to 67 kHz. This reduced the transient signal properties of individual particles passing through the pDv sample volume, yet it was above the design bandwidth of 20 kHz.

Using the modified system configuration, characterization of the flow exiting the 50.8-mm diameter pipe was resumed. Data was again collected at the $x/D = 2$ downstream location to determine if the system modifications improved measurement performance (Fig. 13). Note that the shape of the flow in this plot differs from those presented earlier because these data sets were acquired after straws were inserted into the pipe in an attempt to flatten the velocity profile in the core region.

Although the pDv velocities did not match those of the pitot probe exactly, the results obtained were nonetheless very encouraging. The improvement in data quality indicated that the incorporation of the laser frequency drift minimization system and the integration of PMT signals had diminished the effects of the previously identified problems. Further evidence that system operation was improved was apparent in subsequent testing, which yielded higher quality velocity measurements, particularly at flow centerline. A common characteristic of the data sets obtained in the follow-on studies was that the offset between pDv and pitot probe measurements was nearly uniform indicating that a systemic error source was being overlooked.

The education obtained through experimentation provided a better feel for subtleties of pDv and led to a more appropriate explanation, based on system physics, for the offset between pitot probe and pDv measurements. The conclusion reached was that because the observed offset was uniform, the cause of the problem was probably associated with the data reduction process. The initial suspect was the background subtraction process, however since these levels were both relatively small in magnitude and non-uniform between spatial locations, the degree of offset observed would not be as significant or constant as observed.

Next, the flat-field correction procedure was considered as the source of the offset. Recall that this factor is determined with the laser tuned to a frequency that lies outside of the absorption band of the IVCs to eliminate any optical frequency dependency from the system. During early pDv research activities it was assumed that once the laser frequency was tuned outside of the absorption line to acquire the flat-field data, the ratio was independent of frequency. This assumption was based on the theoretical models of iodine absorption spectra and matching of the laser frequency used to acquire the flat-field data to that used during IVC calibration was not a concern. If this were not true, the scale factor could be different, thus yielding an apparent bias error. This would explain the relatively constant offset (ratio) between pDv and pitot probe velocities in the core.

As evidenced by the results produced in the two-inch pipe flow experiments the selection of the laser frequency for flat-field data acquisition is critical and setting the laser frequency to “top of curve”

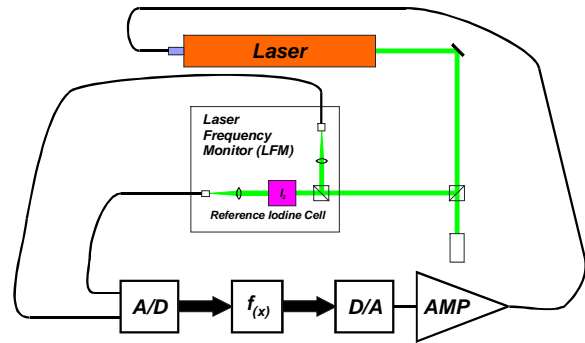

Fig. 12 Laser frequency stabilization system.

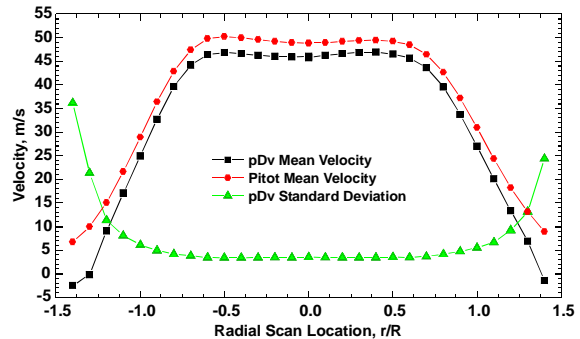

Fig. 13 Pitot probe and pDv measurements acquired at $x/D = 2$ with integrator and laser stabilization systems.

should not be set casually. The selected mode must be as close as possible to the mode used to develop IVC calibrations. From Fig. 14 the *ideal* frequency mode (blue) should be used since the induced Doppler shift during flat-field calibration would not cause any collected scattered light to be absorbed resulting in the most accurate flat-field correction factor. If one of the *suspect* mode settings (red) is selected, the Doppler shift induced by particle motion could cause some of the particle-scattered light to be absorbed, whereas the laser light measured by the LFM would not be. If a suspect frequency is chosen, the scale factor could be incorrect leading to apparent velocity shifts. This results in a flat-field correction value that would introduce velocity biases on the order of magnitude to those found.

To validate the premise that flat-field mismatches were the cause of the observed offset errors, the data set of Fig. 13 was reconsidered. The average ratio between pDv and pitot probe values measurements in the core region ($r/R = \pm 0.7$) was computed. The data set used to generate the plot of Fig. 13 was multiplied by ratio of the pDv measurements to the pitot probe values (1.07). These results show the pDv measurements to be in good agreement with those of the pitot probe, rms error = 0.32 percent, and support the premise that the error lies with the flat field correction factors. It is noted that the difference between the pDv and pitot probe measurements outside of the core was expected, Meyers (1991), since the entrained flow in the jet shear region was free of seed particles, thus biasing the measurements toward the higher velocity seeded flow from the pipe.

5.3 pDv Spectral Quantity Measurement Investigations

Perhaps the most attractive characteristic of pDv is its potential to resolve flow spectral quantities. To gain a better understanding of the ability of pDv to provide these measurements, the spectral content of the flow exiting the 50.8-mm pipe was quantified. pDv data sets were acquired along the pipe centerline at the $x/D = 0, 2$ and 4 downstream stations at a rate of 50 kHz. For comparison purposes, data was then acquired with a hot-wire at the same downstream locations at a rate of 50 kHz. The resultant pDv and hot-wire spectral plots were analyzed and the following observations made: (a) A spike was identified at 355 Hz for all three downstream locations, and, (b) A strong peak at 710 Hz was identified in the $x/D = 4$ spectral record. This frequency indicated that the second order harmonic of the fan blade passages was also being measured. These frequencies coincided with the rate of blade passages of the six-bladed fan driving the flow.

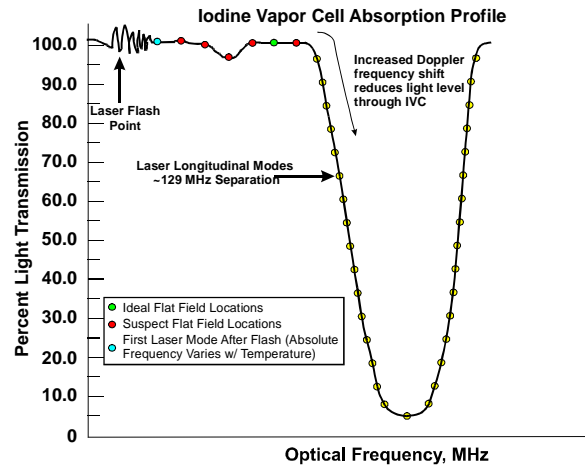

Fig. 14 IVC absorption profile showing frequency modes.

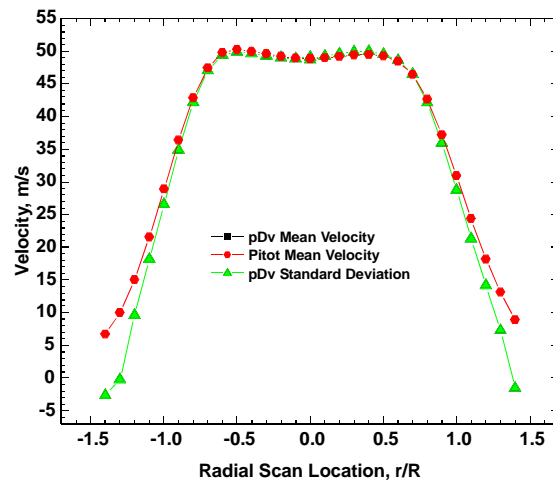

Fig. 15 Results of scaling pDv data set to correct for flat field mismatches.

The fact that the pDv and hot wire spectral plots contained the same frequency peaks at both the fundamental (355 Hz) and secondary (710 Hz) harmonic frequencies of the fan driving the pipe flow, confirmed that pDv was indeed capable of measuring the frequency content of a flow. An area of concern with the pDv measurements was that the noise floor was higher than that of the hot wire, Fig. 17. Follow on investigations suggested that the high degree of noise was the result of PMT saturation and sampling phase mismatch.

6. Summary

A one-component Point Doppler Velocimeter has been developed and its ability to provide accurate and repeatable flow velocity and spectral measurements demonstrated. This level of capability was achieved through a methodical sequence of tests focusing on identifying and resolving error sources. These activities led to the development and incorporation of novel hardware and software elements to overcome problems inherent to the instrument. pDv velocity measurement capability was first assessed by measuring the velocity of a rotating wheel that resolved velocities to within ± 1 m/s of theoretical values. Simultaneous pDv and pitot probe velocity measurements were then obtained from the flow exiting a fully developed, turbulent pipe. Initial measurements were inconsistent, deviating unpredictably from pitot probe results. Findings from these experiments agreed with those of earlier investigations that laser frequency instability compromised instrument measurement accuracies. To diminish frequency variations, a closed-loop, laser frequency drift minimization system was developed. This improved velocity measurement repeatability and yielded flow profiles that better matched the pitot probe. However, the system sometimes exhibited a uniform offset from the pitot probe values. The observed offset, on the order of 3 m/s, was identified to be the result of applying an incorrect flat-field correction factor. Corrections to this scale factor produced average pDv measurements that agreed with the pitot tube data to within 0.32 percent. The ability of the pDv instrument to quantify the spectral components of a flow was also investigated. Spectral data obtained using pDv and hot-wire anemometry clearly showed the same frequency peaks at 355-Hz and 710-Hz that were induced by the blower driving the pipe. The high magnitude of the broadband noise floor limited dynamic range of pDv this was attributed to PMT saturation and sample phase mismatch.

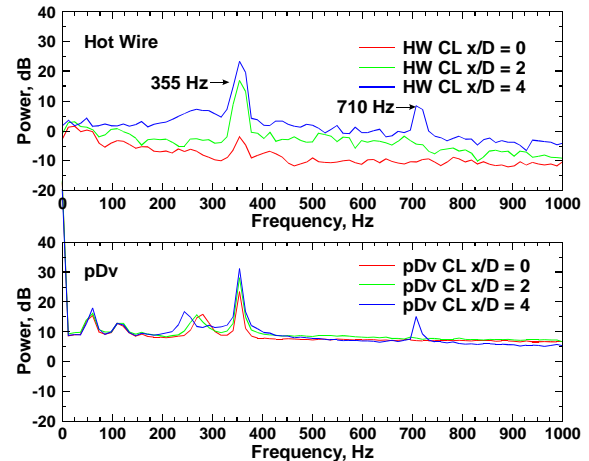

Fig. 16 Spectral content of flow exiting two-inch pipe measured using a hot wire and pDv.

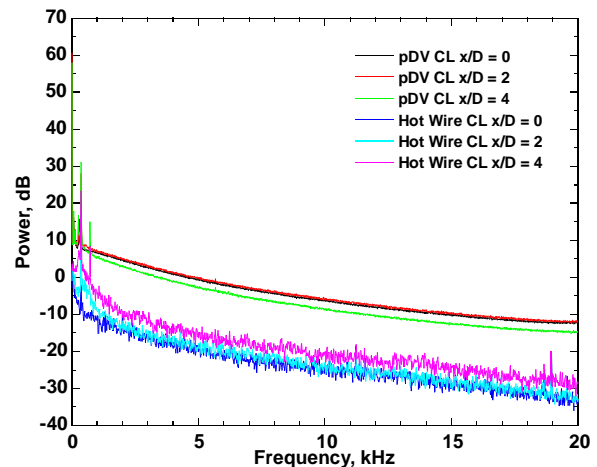

Fig. 17 Comparison of pDv and hot wire spectra measurements.

7. References

- Cavone, A.A.: (2005) The Development of Point Doppler Velocimeter Data Acquisition and Processing Software; MS Thesis, Christopher Newport University, Newport News, Virginia.
- Elliot, G.S.; Samimy, M.; Arnette, S.A.: (1994) *Details of a molecular filtered-based velocimetry technique*. 32nd Aerospace Sciences Meeting and Exhibit, Reno, NV, paper no. AIAA-94-0414, January 10-13, 1994.
- Forkey, J.N.: (1996) *Development and Demonstration of Filtered Rayleigh Scattering – A Laser Based Flow Diagnostic for Planar Measurement of Velocity, Temperature and Pressure*, Princeton University Department of Mechanical and Aerospace Engineering Technical Report 2067.
- Hoffenberg, R.; Sullivan, J.: (1993) *Filtered Particle Scattering: Laser Velocimetry Using an Iodine Filter*, ASME-FED, Vol. 161, pp. 135-8, June 20-24, 1993.
- Komine, H.; Brosnan, S. J.; Litton, A. B.; and Stappaerts, E. A.: (1991) *Real Time, Doppler Global Velocimetry*. AIAA 29th Aerospace Sciences Meeting and Exhibit, Reno, NV, paper no. AIAA-91-0337, January 7-10, 1991.
- Kuhlman, J.M.; Naylor, S.; James, K.; and Ramanath, S.: (1997) *Accuracy Study of a 2 Component Point Doppler Velocimeter (pDv)* AIAA 28th Fluid Dynamics Conference, Snowmass, Colorado, paper no. AIAA-97-1916, June 29-July 2, 1997.
- Kuhlman, J.M.; and Scarberry, T.: (2002) *Point Doppler Velocimeter (pDv) Jet Data Using Avalanche Photodiodes (APD's)*, 22nd AIAA Aerodynamic Measurement and Ground Testing Conference, St. Louis, Missouri, paper no. AIAA-2002-3229, June 24-26, 2002.
- Lee, Joseph W.; Meyers, James F.: (2005) *Increased Accuracy in Molecular Filter Based Flow Field Diagnostics Through Direct Frequency Calibration Using Optical Modulators*. AIAA 43rd Aerospace Sciences Meeting and Exhibit, Reno, NV, paper no. AIAA-2005-33, January 10-13, 2005.
- Meyers, J.F.; Lee, J.W.: (2000) *Identification and Minimization of Errors in Doppler Global Velocimetry Measurements*, The 10th International Symposium on Applications of Laser Techniques to Fluid Mechanics, Lisbon, Portugal, July 10-13, 2000.
- Meyers, J. F.: (1991) *Biasing Errors and Corrections*, von Karman Institute for Fluid Dynamics, Laser Velocimetry, Lecture series 1991-08, Brussels, Belgium, June 10-14, 1991.
- Meyers, J. F.; and Wilkinson, S. P.: (1982) *A Comparison of Turbulence Intensity Measurements Using A Laser Velocimeter and A Hot Wire In A Low Speed Jet Flow*. Proceedings of the International Symposium on Applications of Laser- Doppler Anemometry to Fluid Mechanics, Lisbon, Portugal, paper 17.4, July 5-7, 1982.