

NASA/CR—2005-213656



Water Injection Feasibility for Boeing 747 Aircraft

David L. Daggett
Boeing Commercial Airplane Group, Seattle, Washington

The NASA STI Program Office . . . in Profile

Since its founding, NASA has been dedicated to the advancement of aeronautics and space science. The NASA Scientific and Technical Information (STI) Program Office plays a key part in helping NASA maintain this important role.

The NASA STI Program Office is operated by Langley Research Center, the Lead Center for NASA's scientific and technical information. The NASA STI Program Office provides access to the NASA STI Database, the largest collection of aeronautical and space science STI in the world. The Program Office is also NASA's institutional mechanism for disseminating the results of its research and development activities. These results are published by NASA in the NASA STI Report Series, which includes the following report types:

- **TECHNICAL PUBLICATION.** Reports of completed research or a major significant phase of research that present the results of NASA programs and include extensive data or theoretical analysis. Includes compilations of significant scientific and technical data and information deemed to be of continuing reference value. NASA's counterpart of peer-reviewed formal professional papers but has less stringent limitations on manuscript length and extent of graphic presentations.
- **TECHNICAL MEMORANDUM.** Scientific and technical findings that are preliminary or of specialized interest, e.g., quick release reports, working papers, and bibliographies that contain minimal annotation. Does not contain extensive analysis.
- **CONTRACTOR REPORT.** Scientific and technical findings by NASA-sponsored contractors and grantees.

- **CONFERENCE PUBLICATION.** Collected papers from scientific and technical conferences, symposia, seminars, or other meetings sponsored or cosponsored by NASA.
- **SPECIAL PUBLICATION.** Scientific, technical, or historical information from NASA programs, projects, and missions, often concerned with subjects having substantial public interest.
- **TECHNICAL TRANSLATION.** English-language translations of foreign scientific and technical material pertinent to NASA's mission.

Specialized services that complement the STI Program Office's diverse offerings include creating custom thesauri, building customized databases, organizing and publishing research results . . . even providing videos.

For more information about the NASA STI Program Office, see the following:

- Access the NASA STI Program Home Page at <http://www.sti.nasa.gov>
- E-mail your question via the Internet to help@sti.nasa.gov
- Fax your question to the NASA Access Help Desk at 301-621-0134
- Telephone the NASA Access Help Desk at 301-621-0390
- Write to:
NASA Access Help Desk
NASA Center for AeroSpace Information
7121 Standard Drive
Hanover, MD 21076

NASA/CR—2005-213656



Water Injection Feasibility for Boeing 747 Aircraft

David L. Daggett
Boeing Commercial Airplane Group, Seattle, Washington

Prepared under Contract NNC0466315Q

National Aeronautics and
Space Administration

Glenn Research Center

December 2005

Acknowledgments

This document summarizes the efforts of many participants, all of whom were essential to the successful evaluation of water injection technology as could be applied to future commercial airplanes. The author gratefully acknowledges the contributions of the Boeing team: Airport Strategy, David Nielson; Aerodynamics, James Conlin; Configuration, Phill Rathbun, Lars Fucke, and Scott McKee; Costs/Benefits/Trades, Joe Dortwegt, James Redmond, Gary Thomas, and Bill Carberry; Electrical, Tom Currier; Emissions, Mike Garrison; Propulsion, Matt Naimi, Mark Howe, and Mark Severeid; Structures, Francis Andrews; Systems, Robert Fisher and David Griffith; Testing, William Peterson; Weights, Andy Ouellette. In addition, invaluable help from outside Boeing was also provided by NASA Glenn Research Center, Chris Snyder and Jeff Berton; Engine Companies: Pratt & Whitney Engine, Arthur Becker; Rolls-Royce, Paul Madden and David Butt; GE, Will Dodds and Pam Battle; Pump Manufacturers: Argo-Tech, Jose Vennat; Eaton, Peter Stricker; Turbine Life Calculations: MIT, Anuja Mahashabde and Ian Waitz; Los Angeles International Airport, C. Lin Wang, Dennos Quiliam, David Waldner, and Gary Brown; Conditioned Water Delivery Study: Colorado University, M. Branch, Ben Rushwald, Katherine Bennett, Matthew Hoff, Travis Lang, and Amy Schwartz; CH2M Hill, and Bill Farmer. Lastly, we thank the NASA Glenn sponsor of this work—Robert Hendricks.

This report is a formal draft or working paper, intended to solicit comments and ideas from a technical peer group.

This report contains preliminary findings, subject to revision as analysis proceeds.

Trade names or manufacturers' names are used in this report for identification only. This usage does not constitute an official endorsement, either expressed or implied, by the National Aeronautics and Space Administration.

Available from

NASA Center for Aerospace Information
7121 Standard Drive
Hanover, MD 21076

National Technical Information Service
5285 Port Royal Road
Springfield, VA 22100

Available electronically at <http://gltrs.grc.nasa.gov>

Executive Summary

Can water injection be offered at a reasonable cost to large airplane operators to reduce takeoff NO_x emissions? This study suggests it may be possible.

This report is a contract deliverable to NASA Glenn Research Center from the prime contractor, The Boeing Commercial Airplane Company of Seattle, WA. This study was supported by a separate contract to the Pratt & Whitney Engine Company of Hartford, CT (contract number NNC04QB58P).

Aviation continues to grow and with it, environmental pressures are increasing for airports that service commercial airplanes. The feasibility and performance of an emissions-reducing technology, water injection, was studied for a large commercial airplane (e.g., Boeing 747 with PW4062 engine). The primary use of the water-injection system would be to lower NO_x emissions while an important secondary benefit might be to improve engine turbine life.

A tradeoff exists between engine fuel efficiency and NO_x emissions. As engines improve fuel efficiency, by increasing the overall pressure ratio of the engine's compressor, the resulting increased gas temperature usually results in higher NO_x emissions. Low-NO_x combustors have been developed for new airplanes to control the increases in NO_x emissions associated with higher efficiency, higher pressure ratio engines. However, achieving a significant reduction of NO_x emissions at airports has been challenging. Using water injection during takeoff has the potential to cut engine NO_x emissions some 80 percent. This may eliminate operating limitations for airplanes flying into airports with emission constraints. This study suggests an important finding of being able to offer large commercial airplane owners an emission-reduction technology that may also save on operating costs.

Potential Benefits

Injecting purified atomized water into the combustor of a gas turbine engine will lower the flame temperature. As NO_x emissions are very sensitive to high flame temperatures, the injected water decreases NO_x emissions some 80 percent when a 1:1 water-to-fuel ratio is used. Smoke emissions reductions of approximately 4× have been observed during engine tests. HC and CO emissions will have very small, if any, increases. For a Boeing 747 aircraft, 400 gal of water would be required during its use from takeoff to 3000 ft altitude.

Although water injection was previously used in older aircraft for additional thrust, this benefit was not considered in the study. For example, if this new system failed during takeoff, the aircraft is assumed to maintain the same level of thrust. When keeping thrust constant while using water injection, a 120 °R decrease in turbine inlet temperature was calculated. Most of the life of a turbine blade is consumed during the extreme conditions of takeoff. This 120 °R temperature decrease during takeoff resulted in an estimated 29 percent increase in turbine life for a typical airplane operator. This life extension, minus the associated water injection costs, results in an estimated 0.65 percent reduction in airplane-related operating cost.

Potential Issues

The negative aspects of water injection were a 750-lb system weight increase. For an existing airplane, this can reduce airplane range approximately 60 n mi under some conditions and will consume 20 gal more fuel on a 3000 n mi flight to carry the extra weight. For a newly designed airplane, the study assumed this range shortfall could be restored by increasing the airplane's fuel carrying capability. The 400 gal of water, or 3340 lb of added takeoff weight, also reduces payload capability. However, as the water-injection system is optionally used, the aircraft is assumed not to be filled with water on flights with high passenger load factors. Another negative aspect is a 1.4 percent reduction in the engine's high-

pressure compressor (HPC) surge margin. Some existing engines might be able to handle this level of degradation, but others would have to undergo a turbine rematch, which would result in an estimated 0.4 percent specific fuel consumption (SFC) penalty. A newly designed engine could potentially eliminate this penalty. Test and certification costs for retrofitting an existing engine could approach upwards of \$75 M. Thus, recurring costs for a water-injection retrofit kit, would be much higher than for a newly designed engine. These costs, and the 0.4 percent SFC cruise penalty, make water injection unattractive for retrofitting existing engines. However, for newly designed engines, these negative aspects may be avoided. Other potential negative aspects have to do with engine operating issues and possible unforeseen affects of water injection.

Another method of misting water into the engine, via a finely atomized spray into the low-pressure compressor (LPC), was briefly evaluated. However, a Pratt & Whitney performance model showed that compressor surge margin deteriorated 9 percent for the LPC. This deterioration level was deemed unacceptable and the water-misting approach was not studied further.

Airplane operator acceptance of water injection is unknown. However, in the past, airplane water-injection systems were prone to maintenance difficulties and therefore have gained a poor reputation. With improved design practices, these problems may be overcome, but the technology will probably still be met with much resistance.

Airport infrastructure issues of supplying the conditioned water can be substantial. Although demineralized water costs have decreased substantially from earlier days, providing the conditioned water to airplanes at each airport gate may involve the installation of special supply systems. However, if airports can take credit for the reduction of emissions, the technology may be welcomed by those airports that are constrained by NO_x emissions.

Recommendations

Modern turbofan engines are much more sophisticated than the early jet and turbojet engines that used water injection. Therefore, a modern aviation turbine engine demonstration of water-injection needs to be performed. With engine company involvement, water injection may be an ideal technology for NASA to pursue. To facilitate the potential introduction of water injection into any new engine design, and avoid the prohibitive additional certification costs, the water-injection system design and test should be conducted in concert with new engine research and development (R&D) programs.

Contents

Executive Summary	iii
1.0 Introduction	1
1.1 Purpose	1
1.2 Scope of Work	1
1.3 Potential Benefits	1
1.4 Potential Liabilities	2
2.0 Study Method	2
2.1 Process	2
2.2 Work Tasks	4
2.3 Ground Rules	5
2.4 Airplane Model	5
2.4.1 Airframe	5
2.4.2 Engine Model	7
3.0 Results	8
3.1 Problems With Previous Water-Injection System	8
3.2 New Water-Injection System Design	9
3.2.1 System Layout	10
3.2.2 Water Tanks	14
3.2.3 Tubing	19
3.2.4 Water Pumps	21
3.2.5 Electrical System	23
3.2.6 Water Refill System	24
3.2.7 Strut	26
3.3 Engine System Design	28
3.3.1 Compressor Injection (Water Misting) System Design	28
3.3.2 Combustor Injection System Design	30
3.3.3 Water Purity Requirements	36
3.4 Performance Summary	37
3.4.1 Weights	37
3.4.2 Structures	38
3.4.3 Testing Requirements	39
3.4.4 Engine Performance Impact for Water Injection	40
3.4.5 Engine Performance Impact for Water Misting	45
3.4.6 Turbine Life	46
3.4.7 Emissions	51
3.4.8 Noise	56
3.4.9 Airport	57
3.4.10 Airplane Performance Impact	58
3.4.11 Failure Modes	59
3.4.12 Value of Water Injection	61
4.0 Conclusions and Recommendations	72
4.1 Summary of Results	72
4.2 Analysis of Results	73
4.3 Recommendation	73
4.3.1 Suggested Action	74
4.3.2 Future Planned Work	74

References.....	74
Appendix A—Turbine Life Prediction and Material Maintenance Costs for Water Injection.....	77
Appendix B—Acronyms and Abbreviations.....	95
Appendix C—Trade Study Scope Sheet.....	97

1.0 Introduction

This report documents the results of a NASA-funded study, through the Revolutionary Aero-Space Engine Research program, to evaluate the feasibility and performance of an engine water-injection system installed on a large commercial airplane.

1.1 Purpose

The ultimate purpose of this study is to evaluate and further quantify the feasibility and issues related to reducing airplane NO_x (absolute) landing-takeoff cycle (LTO) emissions more than 50 percent from today's airplanes at minimal cost to the operator.

Water injection is a common industrial gas turbine engine NO_x-reduction technology that can achieve a large reduction of emissions and therefore will be evaluated for use on commercial aircraft.

These study results are important because they determine if water injection could be reasonably utilized on commercial aircraft. In addition, this report provides answers to an earlier NASA-funded study (ref. 1) that questioned whether water *injection* into the combustor or water *misting* into the compressor would be preferable. The earlier study also suggested there might be an improvement to turbine life when using water injection and this study now provides quantitative estimates of turbine life and validates the earlier estimates of engine performance impact.

1.2 Scope of Work

The following trade study evaluates the costs and benefits for various water-injection designs. The alternatives studied include water-injection installation on a newly designed large commercial airplane, a new production airplane (i.e., 747-type aircraft) and the retrofit of Boeing 747-400 aircraft that are already in service.

Boeing Commercial Airplane (BCA) group performed a preliminary design and analysis of the airframe portion of the water misting and injection systems. In addition, a system-level cost and benefit analysis was performed on the entire airplane.

Pratt & Whitney Engine Company performed research on the engine portion of the task. This was supported under a separate contract (NNC04QB58P) by NASA Glenn Research Center. They conducted preliminary design, performance analysis, and cost estimates of the engine portion of the water-injection system.

1.3 Potential Benefits

This study fits with NASA's goals of reducing aircraft emissions and enabling aviation. Water injection benefits are anticipated to

- Reduce airplane takeoff NO_x emissions
- Cut smoke emissions
- Possibly reduce airplane operator costs through improved engine life
- Provide a backup plan to other technologies (e.g., direct injection systems) to reduce airport NO_x emissions
- Optimization of other engine design parameters by not having to focus on reducing LTO NO_x levels

1.4 Potential Liabilities

There would also be issues to address with the water-injection system, which would result in offsetting the benefits. These include

- airline and industry acceptance
- significant engine and aircraft system issues
- water delivery logistics to the airplane
- reliability of the system to avoid its failure while in use at takeoff
- effect of the system on compressor operation
- weight of the system
- uncertain effect on engine durability
- potential for supply water freezing

These benefits will be explored in the following report and weighed against the liabilities for the various concepts with a recommendation made as to how to proceed.

2.0 Study Method

The study method involved laying out a plan (sec. 2.1), figuring out what questions that needed to be answered (sec. 2.2), defining the study assumptions (sec. 2.3), and selecting a case to study (sec. 2.4).

2.1 Process

The study followed the planned steps listed below to ultimately generate a value for water-injection technology.

1. Define Study Airplane (i.e., retrofit B747–400, new production 747, and newly redesigned 747-sized airplane)
2. Obtain airplane takeoff and climbout performance information
3. Calculate amount of water required for the water-injection systems
4. Lay out two water-injection systems on the airframe
 - a. Low-pressure compressor (LPC) water-misting system
 - b. Combustor water-injection system
5. Estimate weight of airframe portion of the system(s)
6. Obtain engine portion of system feasibility, design, and weights
7. Evaluate airplane performance impact
8. Calculate relative value of systems using trade study model
9. Determine which water-injection system offers best value, select one, then return to steps 5 to 9 to add more detail
10. Estimate the nonrecurring and recurring costs
11. Estimate retrofit costs
12. Calculate business case for new and retrofit cases
13. Write final report
14. Industry review of findings and feedback
15. Submit final report

Research was conducted for airframe-related material on water injection. Boeing internal reports were obtained and interviews conducted with staff who worked on the 707, 747-100, 747-200, and DC10-40 commercial airplane programs that had water-injection systems.

The Boeing Integrated Defense System group also provided feedback from their current experience of using water injection on the Boeing AV8B Harrier aircraft with Rolls-Royce Pegasus F402 engines (fig. 1).

Additional design and performance information for the water-injection system was provided by several companies and universities outside of this contract. Rolls-Royce plc. provided engine water-injection design, performance information, and feedback that is included in the report. The Massachusetts Institute of Technology (MIT) provided estimates of turbine life impact of water. The University of Colorado conducted a design study of the water refill system. Argo-Tech and Eaton Aerospace provided water pump design, performance, and cost information, which are also included in the report. An engineering team from CH2M Hill provided data on water conditioning processes and costs. Lastly, interviews were conducted with staff at Los Angeles International Airport to assess the infrastructure issues and desirability of water injection.



Figure 1.—Water injection is currently used on Boeing Harrier aircraft.

2.2 Work Tasks

When selecting the study work tasks, the first step was to determine what systems would be impacted on the airplane by water injection. In addition, work tasks were generated to answer specific questions that were spelled out in the contractor's statement of work.

The work tasks specific to the engine were to be addressed by Pratt & Whitney. Boeing and Pratt & Whitney jointly agreed on the engine questions needing to be answered and fed back to Boeing. The airframe work tasks were addressed by the BCA Company.

Table I describes the study subtasks as well as those people and companies who were responsible for the results.

TABLE I.—STUDY SUBTASK DESCRIPTIONS AND RESPONSIBILITY

Subtask no.	Description	Responsible	Company
1	Study ground rules	Dave Daggett	
2	LSPS and emissions for 747–400	Mike Garrison Paul Schmid	
3	Water flow rate and total required	Dave Daggett	
4	Systems	Robert Fisher	
5	Water pump feasibility, and power and weights	Dave Daggett	Jose Vennat, Argo_Tech Peter Stricker, Eaton
6	Water tank design	Phil Rathbun	
7	747 configuration	Lars Fucke Steve Wald Scot McKee	
8	Airframe system weights	Andy Ouellete	
9	Costs, recurring and nonrecurring	Jim Redmond	
10	Testing required	William J. Peterson	
11	Aero performance (impact of weight)	Jim Conlin Gnanulan Canagaratna	
12	Noise	Bill Herkes	
13	Electrical	Bob Gilbo Kester Powell Tom Currier	
14	Propulsion/strut for water line routing	Mark Severeid Mark Howe	
15	Structures	Francis E. Andrews	
16	CAROC information for 747	Joe Dortwegt	
17	Trade model for 747	Gary Thomas	
18	CAS business case	Eric Palmer	
19	Tubing	David Griffith	Robert Torgerson, Eaton
20	Propulsion performance	Matt Naimi	
21	Airport compatibility—large (LAX)	Dave Nielson	
Engine Portion from Pratt & Whitney			
22	Engine system layout	Art Becker, et al.	Pratt & Whitney
23	T4 versus water-injection rate for combustor injection	" "	
24	T4 versus water-injection rate for compressor misting	" "	
25	Hot section life extension	" "	
26	Engine testing required	" "	
27	Emissions calculation (NO _x , HC, CO, and smoke)	" "	
28	Engine system and certification cost	" "	
29	Engine weights	" "	
30	Compressor surge issues	" "	
31	Other issues	" "	
32	Community noise (side task not in their contract)	" "	

2.3 Ground Rules

Study assumptions need to be established so specific answers can be addressed. Ground rules are listed in table II.

A major assumption was that water injection would not be used for additional thrust. This was to eliminate any issues that might arise due to potential safety concerns. Namely, if the aircraft were to depend on the additional thrust that water injection could offer, and the system failed at a crucial point, the airplane could be put in peril.

<u>Technology and Requirements</u>	
Date:	Technology Readiness is 2007
Aircraft:	Newly designed 747-sized airplane, new 747 production, and in-service 747-400 for retrofit
Engines:	Pratt & Whitney PW4062 for in-service retrofit aircraft. Assume same performance metrics for new engine.
Seating:	Three-class, 416-passenger
Mission:	Design range (e.g., 7580) and 3000 n mi with 70 percent passenger LF
Zero fuel weight:	542 000 lb
MTOW:	910 000 lb
Water system:	(1) Combustor water injection (2) Compressor water misting
LTO NO _x :	50 percent reduction from ICAO for water misting (compressor) 80 percent reduction from ICAO for water injection (combustor)
Requirements:	
Analysis mission length:	3000 n mi
Maximum takeoff thrust:	63 300 (keep constant with/without water injection)
BET:	77 828

TABLE II.—WATER INJECTION STUDY GROUND RULES

2.4 Airplane Model

Due to limited funding, one study airplane needed to be chosen for analysis. In the previous less-detailed water-injection feasibility study (ref. 1), a Boeing 777 airplane was used as this airplane is a high-tech, newly designed baseline aircraft that is used in many trade studies. For this study, a 747 aircraft was chosen. This is because older versions of the 747 previously used water injection, therefore, more design information is available. In addition, these engines were deemed to be easier to incorporate water injection as an aftermarket retrofit kit.

2.4.1 Airframe.—For the case of a current production aircraft (statement of work (SOW) task 1.1), a new Boeing 747-type aircraft was chosen as the study platform. For the case of an in-service aircraft for retrofit (SOW task 1.2), a Boeing 747-400ER aircraft was chosen.

The 747-400ER (extended range) is available in both passenger and freighter versions. It is the same size (fig. 2) as the original 747-400s, but has a higher payload and range. The 747-400ER has a maximum takeoff weight of 910 000 lb (412 770 kg). This takeoff weight increase of 35 000 lb (15 876 kg) over older 747-400s allows operators to fly about 410 n mi (760 km) farther or carry up to 15 000 lb (6800 kg) more payload, either in the form of extra cargo or a full load of 416 passengers. The 747-400ER passenger airplane has a range of 7670 n mi (14 205 km). This version also is available as a freighter. Table III shows the airplane specifications for the 747-400ER.

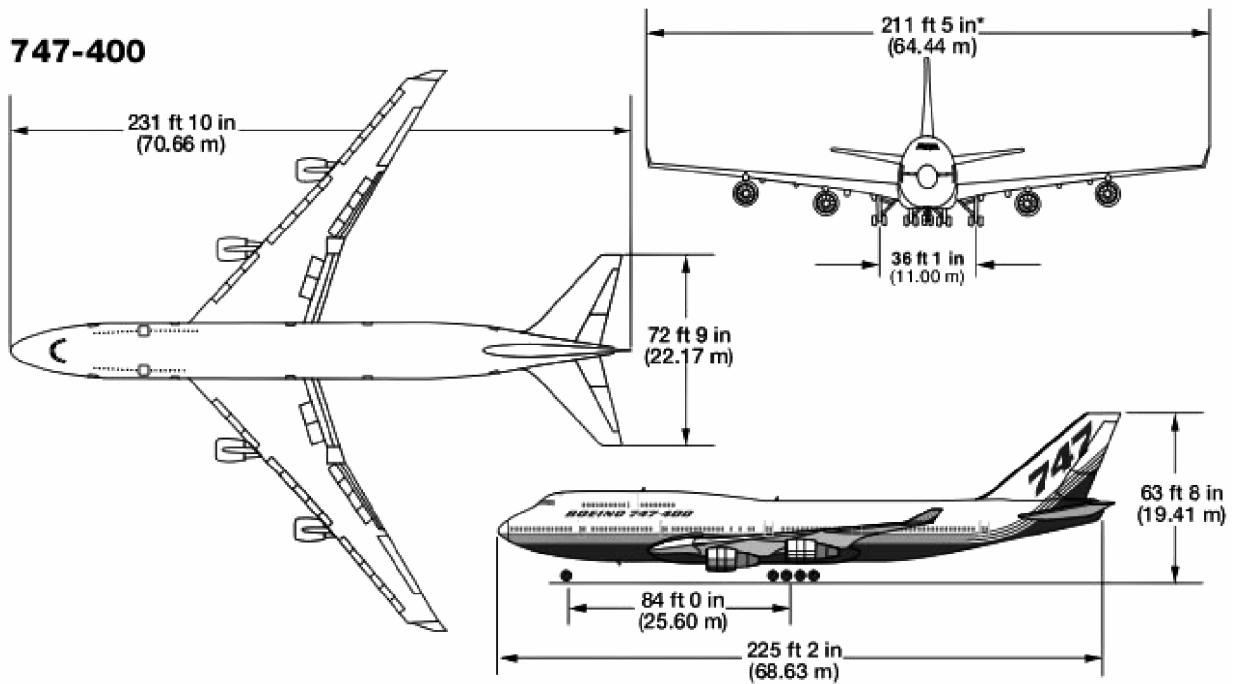

Figure 2.—Retrofit case used 747–400ER as the study airplane platform.

TABLE III.—TECHNICAL SPECIFICATIONS FOR 747–400ER USED FOR RETROFIT STUDY CASE

Passengers	
Typical three-class configuration	416
Typical two-class configuration	524
Cargo	5599 cu ft (158.6 cu m) or 4837 cu ft (137 cu m)
Engines	
Maximum thrust	Pratt & Whitney PW4062 63 300 lb (281.57 kN)
Maximum fuel capacity	63 705 gal (241 140 L)
Maximum takeoff weight	910 000 lb (412 775 kg)
Maximum range	7580 n mi (14 205 km) Typical city pairs: New York to Hong Kong, Los Angeles to Melbourne, Singapore to London
Typical cruise speed	0.855 Mach
At 35 000 ft	567 mph (912 km/h)
Basic dimensions	
Wing span	211 ft, 5 in. (64.4 m)
Overall length	231 ft, 10 in. (70.7 m)
Tail height	63 ft, 8 in. (19.4 m)
Interior cabin width	20 ft (6.1 m)

The 747 was originally designed in the 1960s (and included water injection) but has experienced significant updates accompanied by several model changes. The major milestones for the 747 program are

- April 1966—First 747 order
- Sept 1968—747 rollout
- January 1970—747-100 first placed in service
- June 1971—747-200 placed in service
- April 1976—747SP (special performance)
- March 1983—747-300 in service
- February 1989—747-400 in service
- November 2002—747-400ER in service

For the new airplane case study, it was assumed that a 747-sized airplane would be used. A current production airplane would suffer many of the same water-injection system nonrecurring development costs as a retrofit airplane. Therefore, study assumed that a new airplane would be developed to include water injection. Figure 3 shows the new production and retrofit airplanes used in the study.

For the newly designed airplane, a PW4000-type engine was used in the analysis. In this case, the engine would be developed from new with an optional water-injection system designed into the configuration.

2.4.2 Engine Model.—For the retrofit and production airplane study cases, the airplane was considered to have PW4062 engines. This series of engines were the first model in Pratt & Whitney's high-thrust family for large aircraft and achieves a top thrust rating of 62 000 lb of thrust for the 747. The engine has single-crystal superalloy materials and full-authority digital electronic control (FADEC). The engine is used on the Boeing 747 and 767, as well as two other European airplanes.

In November 2002, Pratt & Whitney certified a new high-pressure compressor (HPC) case design for the engine. The design is based on the PW4000-112 and has begun production incorporation and is also available to airlines for incorporation at overhaul. The new design was needed to improve compressor blade tip clearance control, which also resulted in improved fuel efficiency, performance retention, and exhaust gas temperature (EGT) margin.

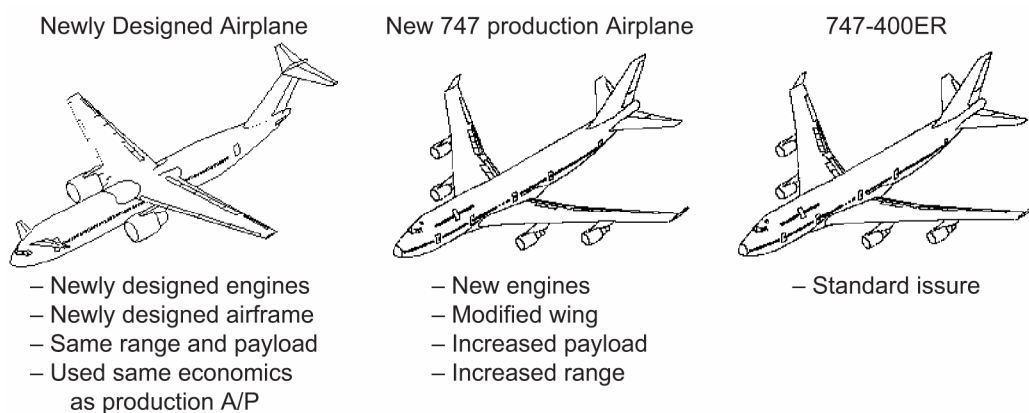

Figure 3.—A new 747-sized airplane, a new production 747, and a 747-400ER were used for the airplane study platforms.

Engine Characteristics

Fan tip diameter: 94 in.
Takeoff thrust: 52 000 to 62 000 lb
Flat rated temperature: 86 or 92 °F
Bypass ratio: 4.8-to-1 to 5-to-1
Overall pressure ratio: 27.5 to 32.3
Fan pressure ratio: 1.65 to 1.80

Program Milestones

December 1982—Program launch
August 1985—First flight
June 1987—Revenue service
November 2002—Federal Aviation Regulation (FAR) 33 Certification HPC Ring Case

3.0 Results

An airframe water-injection system was designed, based primarily on the heritage 747–200 water-injection system, for the combustor water-injection system and the compressor water-misting system. Airframe system weights were calculated and combined with engine system weights obtained from the subcontractor. Airplane performance impact was calculated from aerodynamic models. These performance results, plus engine maintenance numbers obtained from the subcontractor, along with estimated engineering nonrecurring and airplane recurring costs, were fed into several design trade models to evaluate the relative worth of water-injection technology. An estimated customer business case was calculated.

3.1 Problems With Previous Water-Injection System

Figure 4 shows some of the maintenance issues that were identified with the early water-injection system on the Boeing 747. On the airframe side, 6061–T6 aluminum tubing was used for the water supply and distribution systems. The engine requires demineralized water which is more corrosive to the airframe water tanks and tubing material than ordinary tap water. This resulted in substantial corrosion taking place which often blocked valves and controllers and also lead to corrosion of the wetted portions of the water pump. In addition, the location of the water tanks in the wing lead to some freezing problems.

On the engine side, the earlier engines had a spray distribution bar that was placed downstream of the HPC diffuser. This water-injection method resulted in some water, or cooled air, impacting the engine case that lead to distortion and thermal stressing problems. In addition, a sizable portion of water-cooled air was thought to enter through the combustor dilution holes, which are located just upstream of the high-pressure turbine nozzle and blades. This resulted in increased noise and a poor thermal pattern factor, which can significantly reduce the life of the engine turbine blades. The water-injection system was activated via a microswitch on the throttle quadrant. Perhaps introducing water suddenly in this manner might have also resulted in thermal shock to the hot section. Many who remember water injection also remember these associated maintenance problems, therefore older water-injection systems have acquired a poor reputation.

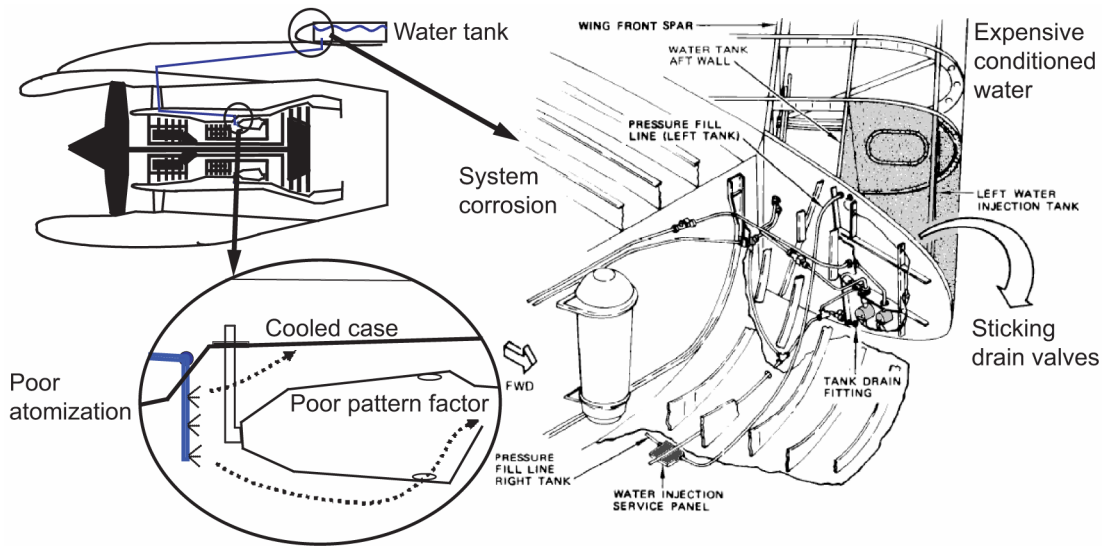
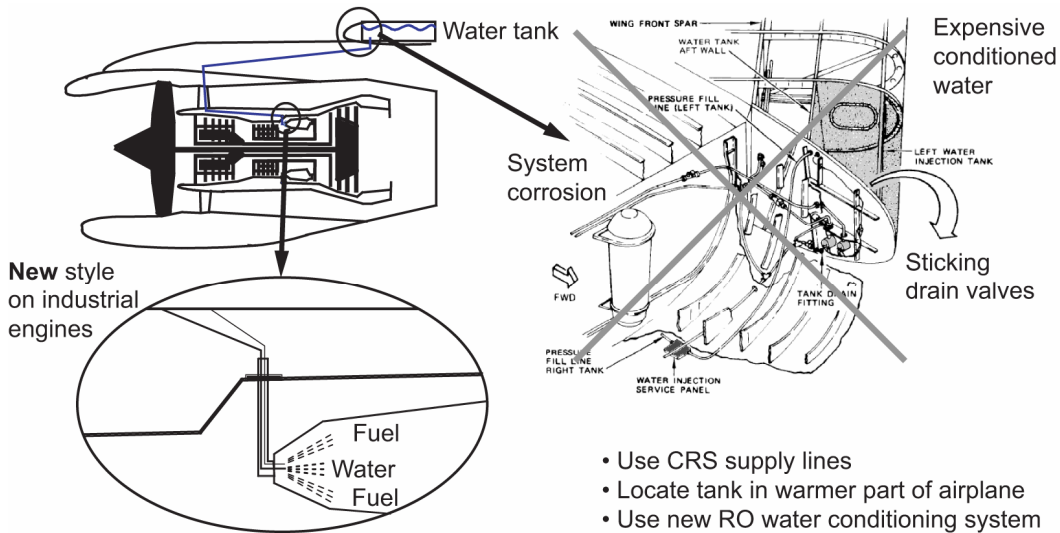

Figure 4.—There were several problems with older water-injection systems, which gave it a poor reputation.



Use industrial engine's dual water/fuel nozzles

Figure 5.—Good design practices can address previous water-injection problems.

3.2 New Water-Injection System Design

The previous section (3.1) of this report showed that there were several durability shortfalls with the original water-injection system. These previous problems can be overcome by being cognizant about them and using good design practices for future water-injection systems.

Figure 5 illustrates that the previous system corrosion problems can be addressed by using corrosion-resistant steel (CRS). In addition, new composite materials can be used to replace many of the older aluminum parts. The freezing problems in the water tanks can be addressed by locating the tank into a warmer part of the airplane. The engine maintenance problems can be addressed by using the type of water-injection nozzle used in current industrial engines. The previous high cost of conditioned water can

be addressed by the implementation of newer reverse osmosis (RO) water conditioning equipment (ref. 1). Portable water conditioning units on the market in 2004 delivered water for less than \$0.02 per gal. For fixed base units, the costs would be around \$0.01/gal (ref. 8).

3.2.1 System Layout.—Three airframe-based water-injection system schemes were studied: single pump, dual pump, and quad pump configurations. The quad pump configuration, where each engine has one water-injection pump, was the final selected configuration. This was due to electrical in-rush current issues and weight associated with the other configurations.

For either the water misting or (one-, two-, or four-pump) water-injection system designs, several common airframe themes need to be addressed; water freezing is one. Once the water is exhausted after takeoff, any residual water needs to be drained through a heated drain mast. If water were to be used all the way to top of climb, the tanks would need to be protected from freezing. On days when the ambient temperature approaches freezing conditions (i.e., 32 °F for water injection or 40 °F for water misting), the operator could either choose to not use the system or takeoff within a prescribed period of time (i.e., within 60 min if the water was 50 °F or higher at refill).

The pump needs to provide a fluid pressure higher than the combustor pressure to atomize the water in the injection nozzle. However, very high pressure will require too much power to drive the pump. These are discussed in more detail below.

3.2.1.1 Single Pump Configuration: In this configuration, one electrical motor and pump would supply water to all four engines. This design was not chosen because the pump's drive motor had too high of an in-rush current for the airplane's electrical supply system. In addition, the pump manufacturer reported that a single large electrical motor was much heavier than four smaller electrical motors; at least for this design round.

Figure 6 shows the initial design concept of the single pump system. The heart of the system is an 800-psi, 240-gpm water pump. The original design assumption for this configuration was that a single pump and support tubing would be lighter weight and less complex. A single pressurized water supply line would run forward from the pump and then split into smaller supply lines to each engine, thereby saving weight.

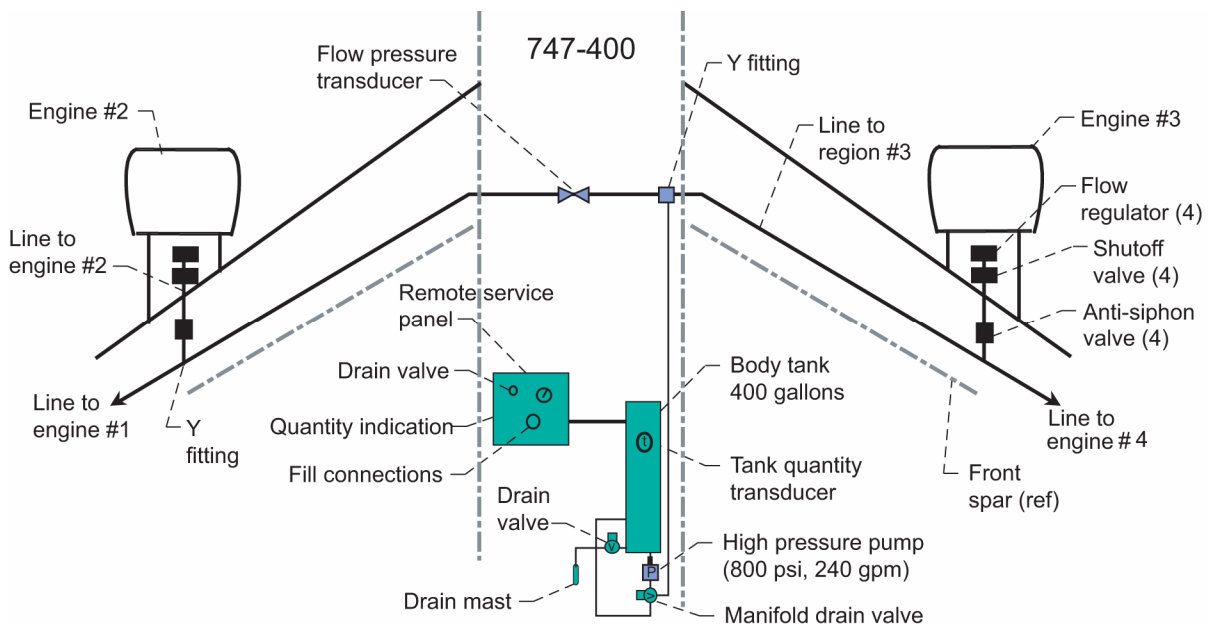

Figure 6.—Single-pump water-injection system concept.

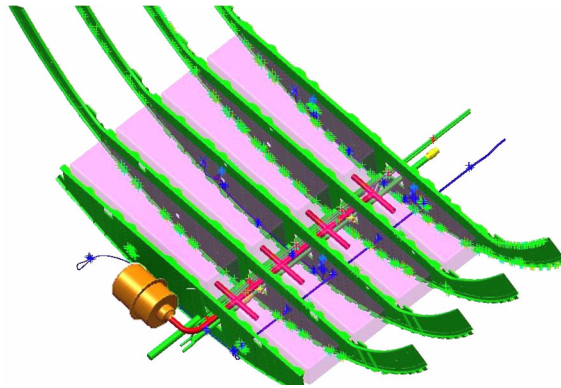

Figure 7.—Single-pump installation would have a very large, heavy electrical motor.

The water-injection pump’s electrical drive motor was the determining factor in this system not being selected. Namely, a single motor in the 200 hp range was a nonstandard design. The motor manufacturer was unsure of the weight associated with this type of challenging design and therefore provided a conservative (i.e., heavy) weight. In addition, the motor would exhibit a large electrical in-rush current that would overwhelm the aircraft’s electrical system. More details for the single pump performance are found in section 3.2.4.

Although not explored in detail, one possible solution to this would be to drive the water pump with a pneumatic motor. As the pumps are located relatively close to the Environmental Control System (ECS) packs, the pumps could conceivably be driven with compressed air diverted from the ECS packs.

The suction feed lines would be joined in a common manifold as shown in figure 7. The pump is very sensitive to cavitations so the first tank to run dry would shut down the system.

Other issues, as illustrated in table IV, are the control of the water delivery system and safety concerns. When a single pump is supplying water to four engines with different consumption levels, it becomes more difficult to maintain pump pressure and overall flow rate.

There could be a potential safety issue with the single-pump configuration. Namely, during operation, there is 112 (fluid) hp of energy in the single water supply line running under the cargo floor. If the line should rupture, it could release enough energy to damage other components. This would need to be further investigated.

TABLE IV.—SINGLE WATER PUMP DESIGN PROS AND CONS

Pros	Cons
Simpler system	(Nonstandard) pump motor (heavy)
Less tubing	Very high in-rush current
Lightweight potential	Tank water distribution (first tank to run dry cavitates pump)
	More control issues between one pump and four engines
	Potential safety issue if single supply line bursts (more available energy)

3.2.1.2 Dual Pump Configuration: In this configuration, two pumps supply water to four engines. This configuration was also not selected as the optimal design as there was also an in-rush current issue and the two pumps weighed more than four pumps.

Figure 8 shows a high-level design of the proposed two-pump water-injection system. It incorporates two 800 psig, 120 gpm pumps with electrically driven motors. Each of the combined electric motor and pump were estimated to weigh 120 lb. This is much higher than two of the existing 60 gpm single pumps that weigh 27.5 lb each.

Figure 9 illustrates the pump installation scheme and proposed water tanks. Four of the eight water tanks would be manifolded together and a pump installed into one of the tanks with a suction feed line to the bottom of that tank. The other four tanks would be similarly manifolded together with the second

pump installed into one of those tanks. Two high-pressure feed lines would run forward from the two pumps.

Table V lists the design pros and cons of the two-pump water-injection system configuration. This system was originally thought to have weight and simplicity benefits over a four-pump configuration. However, the pump manufacturer (ref. 2) claimed the motor and pump configuration would still weigh more, and have high in-rush current issues. More detailed pump information is listed in section 3.2.4.

TABLE V.—DUAL PUMP PROS AND CONS

Pros	Cons
Simpler system than four-pump	Heavy electric pump motor
Less tubing	Still too high in-rush current
Lighter weight potential	

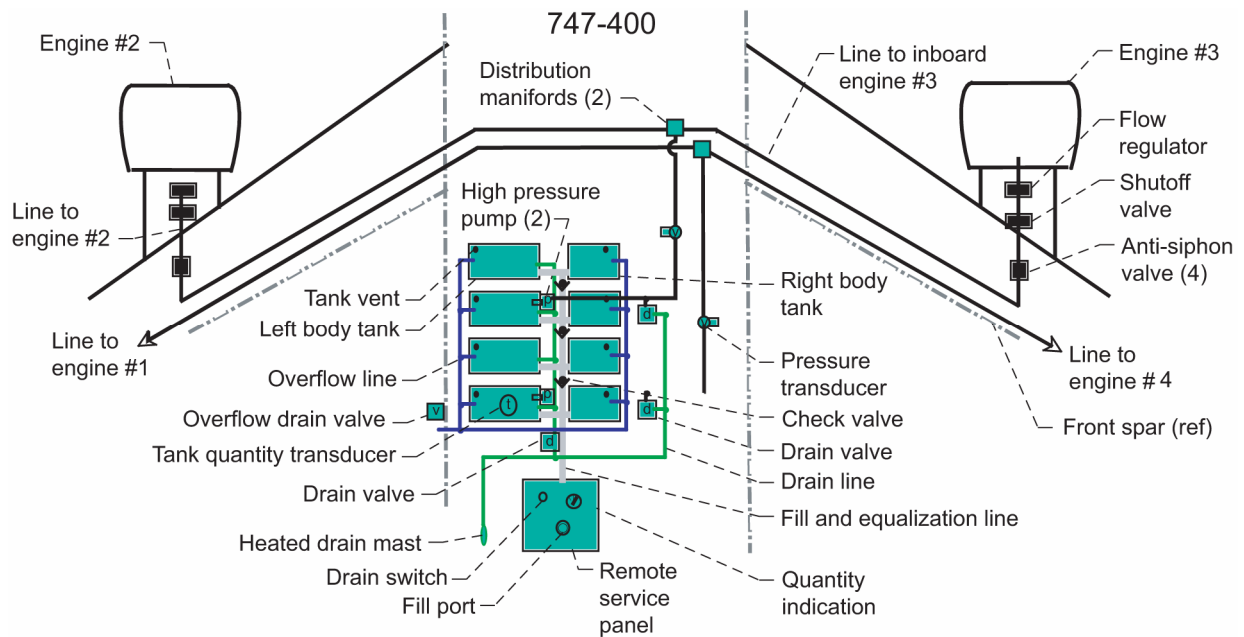

Figure 8.—Dual water pump configuration.

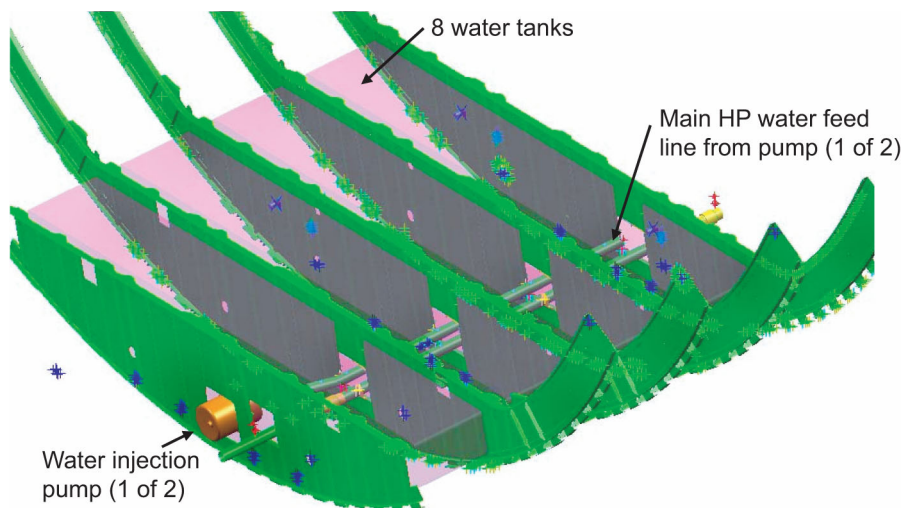

Figure 9.—Dual-pump installation into water tanks.

3.2.1.3 *Quad Pump Configuration*: This was the ultimate configuration chosen for the water-injection system. It exhibited the lightest weight and easiest means of dealing with the current in-rush issues.

Figure 10 shows the layout for the airframe portion of the water-injection system. It incorporates four 800-psig, 60-gpm pumps. Each pump is installed in one of the left water tanks. Each of those tanks are manifolded to an adjacent right water tank.

A water service panel (13) is mounted on the bottom part of the aircraft where the ground service personnel would fill the aircraft with 400 gal of demineralized water through the fill port (4). A fill and equalization line (7) leads from the service panel and connects all the tanks. Three check valves (21) are installed on the fill line to prevent water from draining from the most forward tank to the aft tanks during aircraft takeoff and climbout. An overflow line (11) is connected to each tank so that water can drain overboard in the event the ground service personnel do not pay attention to the quantity indication gage (5) and the tanks are overfilled.

The tanks and supply lines need to be drained after the water is consumed at a 3000-ft altitude. A solenoid drain valve (20) is connected to each of the pressurized lines. This valve, the antisiphon valve (17), and the engine drain line (not shown) open to drain the lines and prevent the entrained water from freezing. The water tanks are drained via a tank drain valve (18) to a heated drain mast (21) that is located on the outside, bottom part of the aircraft. The tank vents (24) equalize the pressure inside the tanks with the cabin pressure. The higher cabin pressure inside the tanks assures positive water drain flow through the system to the outside of the aircraft where atmospheric pressure is lower. Once the system is drained, the drain valves close to prevent excessive pressure differential on the tanks which could ultimately collapse the tanks.

Pressure transducers (15) are located on each pressure line to signal the engine that water is available for injection and also assist the flow regulator (12) to control the water flow. The flow regulator would gradually introduce water to the engine to avoid thermally shocking the hot section. In addition, each pump would shut down when a pressure loss signal is received.

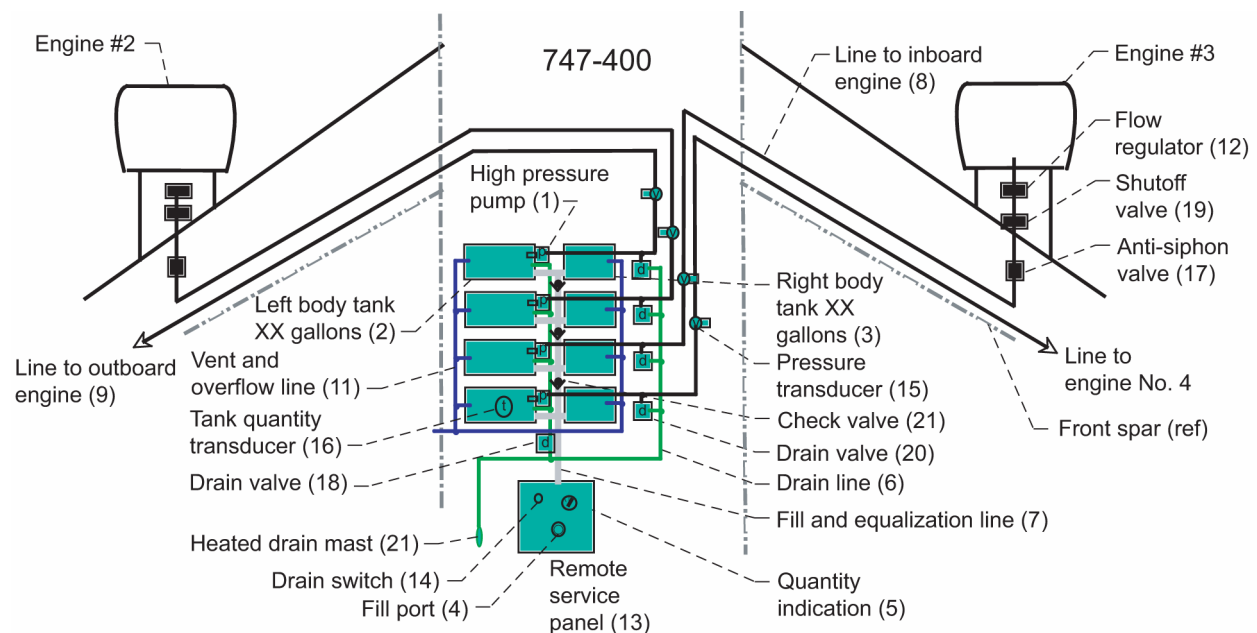

Figure 10.—Quad-pump design for water-injection system was chosen.

Item number	Quantity	Description	Specifications
1	4	Pump, water injection	60 GPM, 800 psig
2	4	Tank (left)	24H x 61L x 14.6D
3	4	Tank (right)	23H x 42L x 14.6D
4	1	Fill port, water	
5	1	Indicator, quantity	
6	8	Line, drain	0.75 in. OD, composite line
7	1	Line, fill	1.75 in. OD, composite line
8	2	Line, inboard engine supply	1.25 in. OD, x 0.028 in. x 1390 in., Ti line
9	2	Line, outboard engine supply	1.25 in. OD, x 0.028 in. x 1885 in., Ti line
10	4	Line, pump suction	2.0 in. OD, 6 in., composite line
11	8	Line, overflow	1.0 in. OD, x 0.028 in., 6061-T4 line
12	4	Regulator, engine supply	
13	1	Service panel, water fill	
14	1	Switch, drain	
15	4	Transducer, pressure	
16	4	Transducer, quantity	
17	4	Valve, siphon	
18	1	Valve, drain manifold	
19	4	Valve, engine shutoff	
20	4	Valve, line drain	
21	4	Valve, check	
22	1	Drain mast, heated	
23	1	Valve, overflow shutoff	
24	8	Vent, water tank	

Figure 11.—The 747 water-injection simple parts list for study.

Figure 11 shows a high-level parts list that was used in the study for the quad-pump water-injection system. Much of the selected system is similar to the heritage 747–200 water-injection system. Many of the smaller parts (clamps, fittings, wire connectors, etc.) were not included in this parts list in order to make the study more manageable.

Details of critical system components in the water-injection system are discussed in the following sections.

3.2.2 Water Tanks.—Selecting the location of the water tanks turned out to be a very involved work task. It was originally envisioned that two, 200-gal water tanks would each be placed in the same wing root location as the heritage 747–200 water-injection system (fig. 12).

The overall benefits of this location were being able to locate the tanks close to the engine, that it is a relatively unused space, there might be less resistance from the design community since the airplane had tanks there previously, and there is good structural support available in this area.

However, four concerns were found with locating the water tanks in the wing roots. As shown in the left portion of figure 13, when looking inside the wing leading edge from the wing root towards the wing tip, one sees that the present ECS duct runs directly through the space where the water tanks would be placed. This could be moved for new airplane designs, but presents a challenge for retrofit cases.

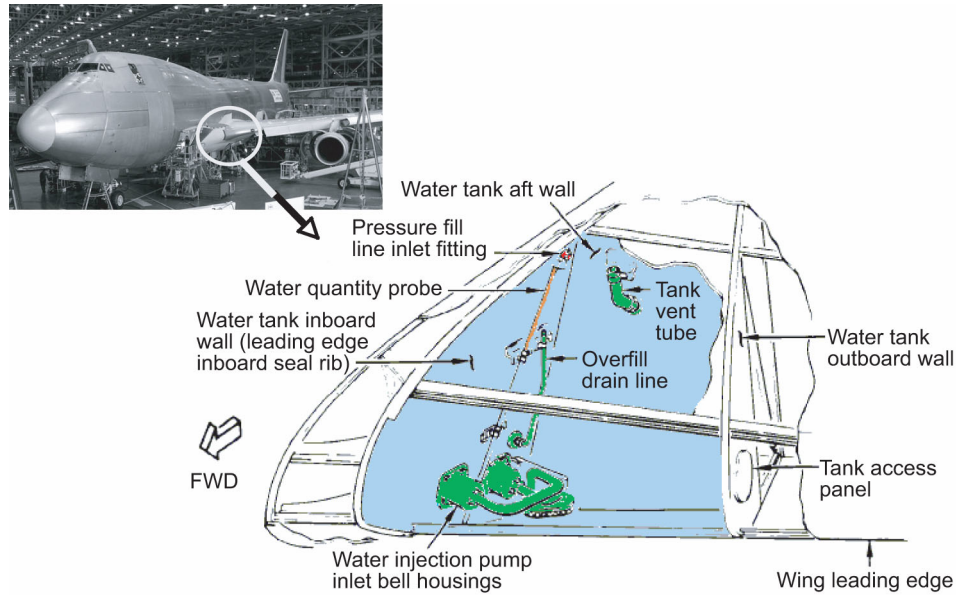

Figure 12.—First considered traditional water-injection wing tank location.

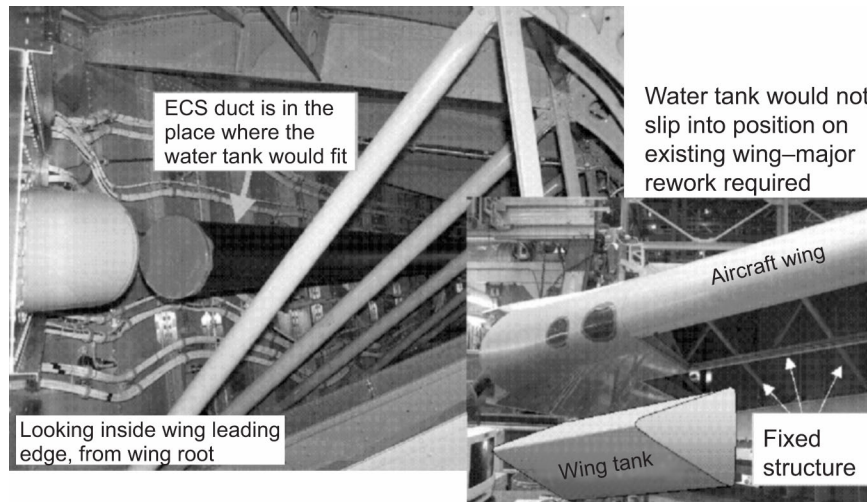

Figure 13.—Wing tanks would be very difficult to install for a retrofit and ECS duct location would need to be changed.

Secondly, a design assumption made for this study, was that the water-injection system should be able to fit a new airplane design as well as a retrofit airplane. In this case, for a new airplane design, the wing root space on future designs is anticipated to be occupied by the Ram Air Turbine so that only one wing could contain a water tank. There is insufficient space in the present wing root to house one 400-gal water tank.

Thirdly, another issue is the ease of retrofit-ability of the water-injection tank. Looking at the right-most part of figure 13, one sees the approximate shape and dimension of a 200-gal water tank. Not only is the ECS duct in the way, but in order to fit the water tank into the space, much of the existing fixed structure would have to be reworked. This would involve substantial structural rework that would undoubtedly result in a much more expensive retrofit option.

Lastly, mounting the tank in the wing would subject any water to freezing conditions. Although this issue was manageable for older aircraft, it did present the operator with another operability issue to contend with.

For the above reasons, another location for the water-injection tanks was needed. Fortunately, this study was able to borrow ideas from another Boeing study that looked at relocating the potable water tanks from the front spar of the aircraft. Of these options, the most probable location for the 400-gal-water-injection tanks was under the cargo floor, just aft of the main wing box spar (fig. 14). The advantage of this location is that it is out of the extreme cold environment, is much easier to access and retrofit, and the tanks are much easier to remove for inspection or repair. The disadvantages are that the tanks are further away from the engines (adds weight due to increased tubing length) and the multiple tanks were required to reach 400-gal capacity.

Available space on an airplane is often difficult to find. This open space was previously occupied by a cargo loading mechanism that was removed on newer model 747-400ER airplanes. Figure 15 shows the open area where the water tanks would be installed. There are some wires that would need to be moved to accommodate the tanks.

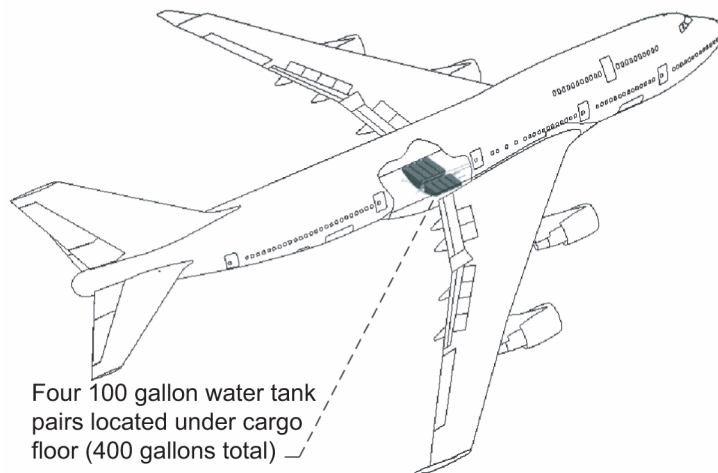

Figure 14.—The 747 water tank location selected was located under the cargo floor.



Water injection tank area during airplane construction

Area under cargo floor of Boeing 747-400

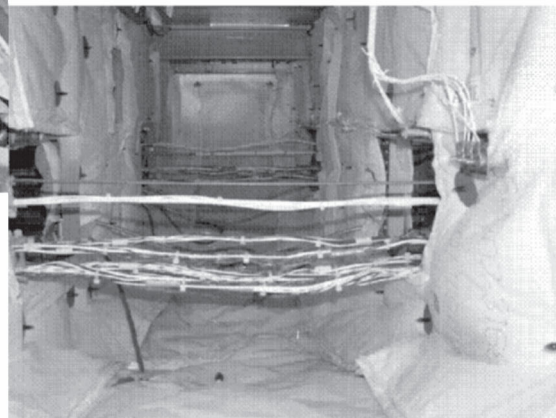

Figure 15.—This location on 747 is available to house 400-gal water tanks.

There are also several tubes and ECS ducts in this location that are not shown in the figure. These are more difficult to move, therefore, each of the four tanks would need to be split in half. Figure 16 shows the tubing running up through the middle part of the aircraft and the tank pairs that would be installed to fit between the structural frames.

Figure 17 shows a CAD model of the installed water tanks from the top view. Each tank measures 14.6 in. deep to fit between the 747 aircraft structural frames. The left tank measures 61 in. wide and the right tank measures 14.5 in. wide. These tanks are anticipated to be manufactured from composite material to reduce weight and eliminate any corrosion problems.

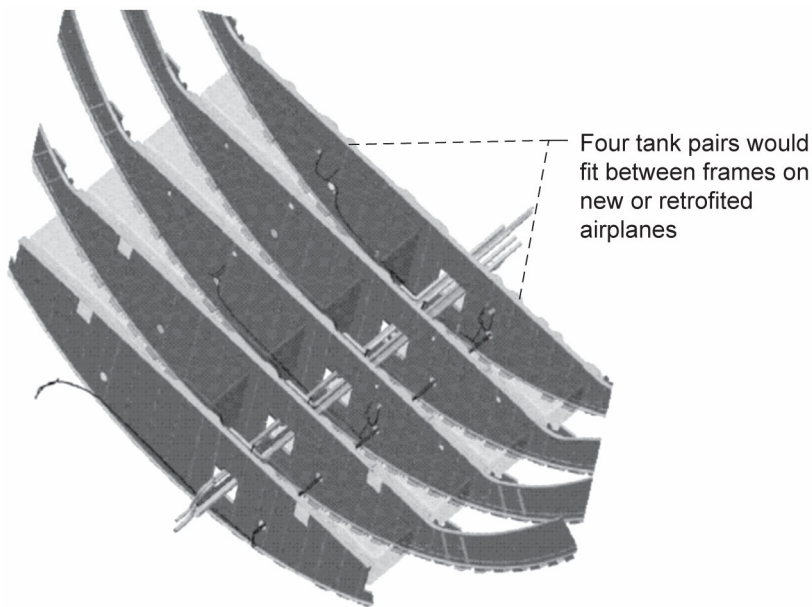

Figure 16.—The 747 water-injection tanks would fit between frames.

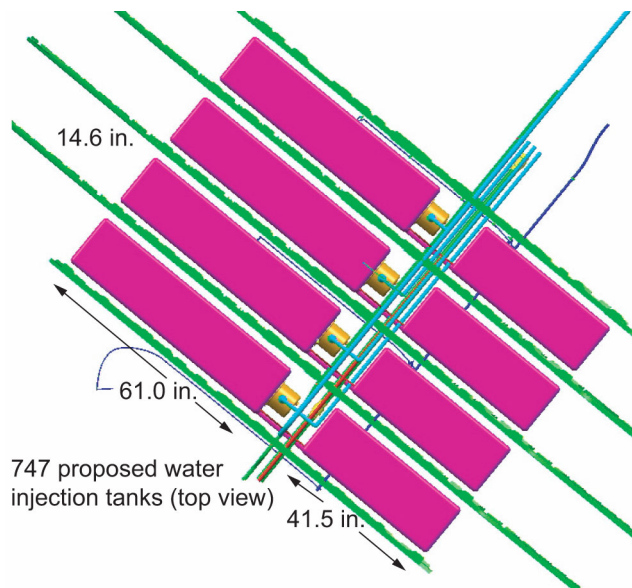

Figure 17.—Proposed 747 water-injection tanks (top view).

The three-view illustrated in figure 18 shows the tanks looking from the front part of the aircraft aftwards. The tank on the port side of the aircraft measures 24.3 in. high and has a 75 gal capacity. Room needs to be made for water and air expansion, as well as tank venting, and therefore, the fill capacity is limited to 63 gal. The starboard tank measures 22.7 in. high and has a 45 gal capacity with a 38 gal fill capacity. Together, each pair of tanks has a fill capacity of 100 gal of water.

Each of the tanks on the left (port) side of the aircraft incorporates a water pump as shown in figure 19. The pump portion resides inside the tank while the electric motor is positioned outside the tank. A suction feed line attaches to the pump inlet and runs to the bottom of the tank (not shown). A composite equalizing line runs between the two tanks to assure they have the same water level because the pump draws water only from the left tank. Overflow lines from each tank are shown leading to a common line.

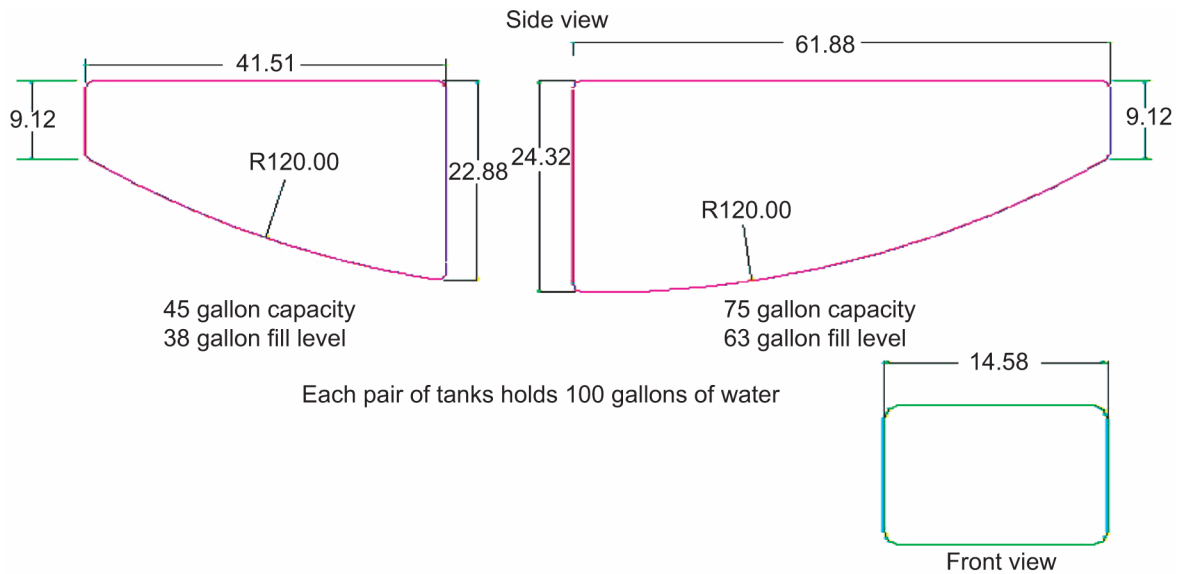

Figure 18.—Proposed 747 water-injection tank (front and side views).

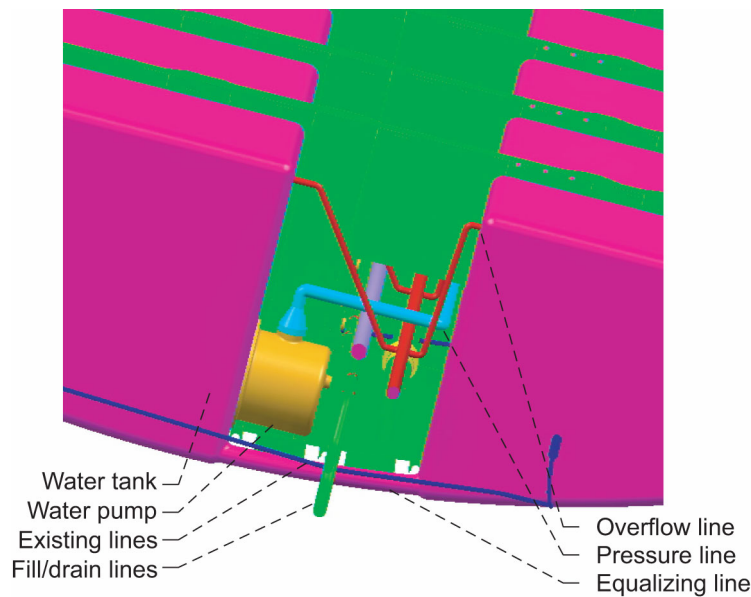

Figure 19.—Boeing 747 water-injection tank with water pumps.

Each of the water pumps has a dedicated 1.25-in. OD (outer diameter) water line running forward to the engine it serves (fig. 20). These water lines are anticipated to run parallel to other tubing that runs along the length of the aircraft.

In the event of a catastrophic engine failure, water tank leakage paths and tank penetration need to be addressed.

3.2.3 Tubing.—As the water tanks are located aft of the main wing box, there will be a substantial distance between the tank-mounted water pumps and the engines. Figure 21 illustrates that the approximate distance is 1884 in. (157 ft) to the outboard engine and 1391 in. (116 ft) to the inboard engine. This long distance will result in fluid pressure loss and higher tubing weight. Therefore a large diameter tube needs to be used to reduce line losses and weight issues become important.

The heritage 747–200 water-injection system used 6061–T6 aluminum tubing in the supply and pressure lines. Demineralized water can be more corrosive than ordinary tap water. Presumably it was this material incompatibility that led to the many corrosion problems this system experienced. Therefore, a corrosion-resisting steel is proposed to be used. The weight penalty of these materials are typically higher than aluminum. Section 3.4.1 shows that a stainless steel tubing would weigh approximately 325 lb. For this reason, lighter weight (but more costly) titanium tubing was used in the design. The tubing weight for this material was estimated to be 210 lb.

One of the difficulties in working with titanium tubing is that special fittings and installation methods are required. “Off the shelf” aerospace fittings are available in sizes up to 1.5-in. OD for operating pressure up to 5000 psi and are constructed of 6Al–4V titanium. Figure 22 shows the installation of a fitting on the left and the special compression tool on the right.

As the wing flexes upwards and downwards during flight, other flexible full coupling fittings also need to be used on the wing to allow flexure in the water-injection lines.

All of the titanium lines are to be drained of water after each use of the water-injection system. This is to avoid the possibility of water freezing in the lines. The drain line is attached to a heated drain mast that is located on the bottom of the aircraft (fig. 23). The drain mast is envisioned to be similar to current water drain masts that have vortex generators designed into the bottom of the mast to direct water downwards and away from the aircraft so that ice does not accumulate on the bottom of the aircraft.

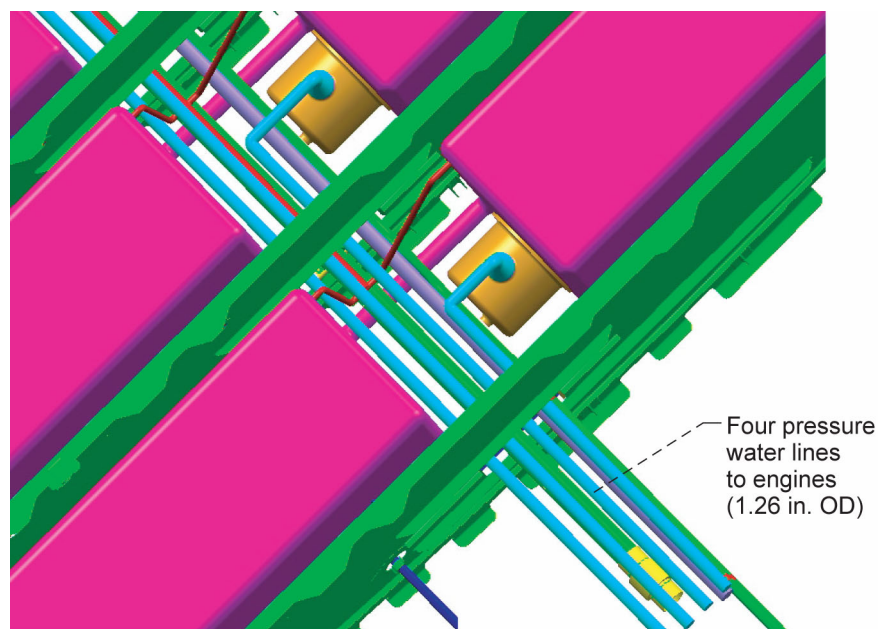

Figure 20.—Boeing 747 water-injection tanks use 1.25-in. OD pressure lines.

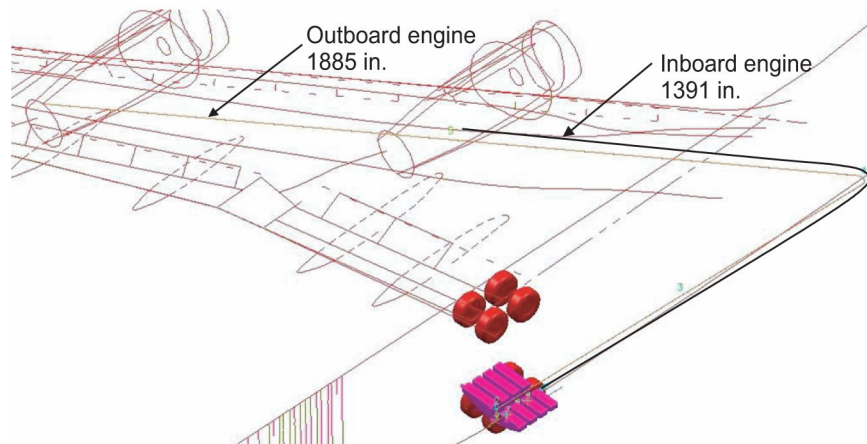

Figure 21.—Boeing 747 water-injection system pressure supply line dimensions.

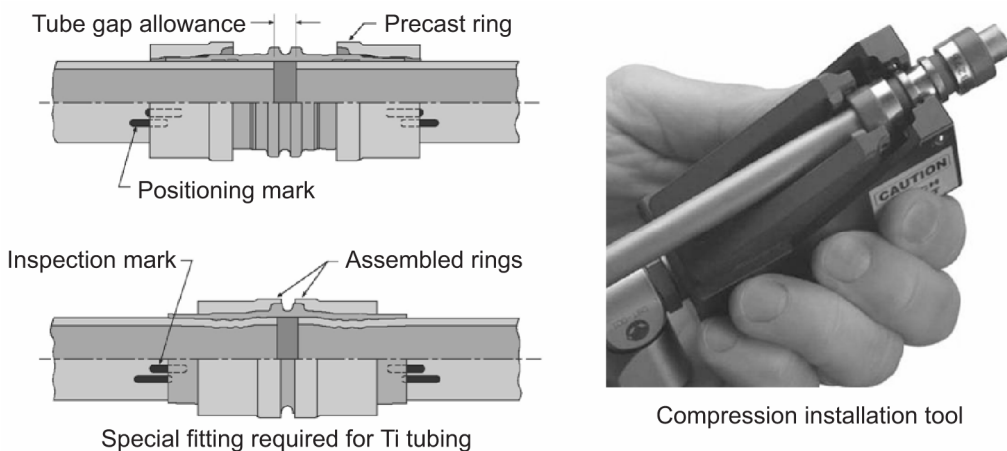
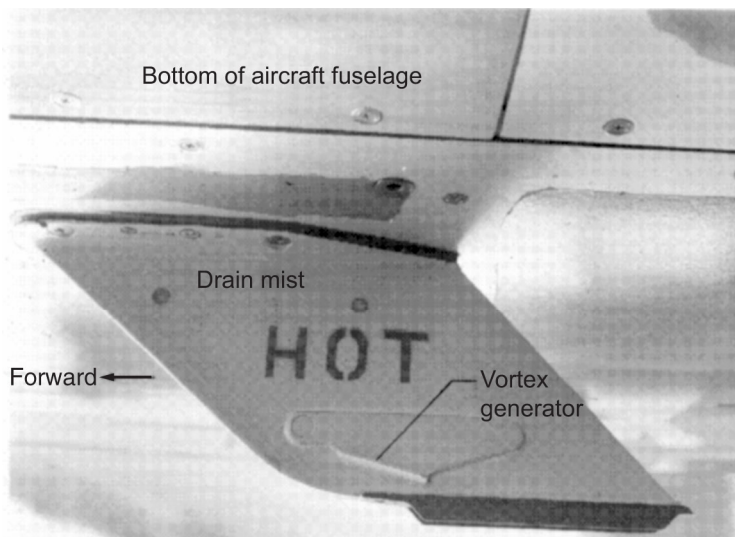

Figure 22.—Titanium tubing and high-pressure fittings would most likely be used to reduce weight and corrosion problems.



Heated water line drain mast with vortex generators used to prevent water from impinging on fuselage

Figure 23.—Water drain mast must be heated to avoid ice formation.

3.2.4 Water Pumps.—Three sizes of water-injection pumps were evaluated from two different manufacturers (refs. 2 and 3). The pump sizes corresponded to using one, two, or four pumps to feed water to the engines and would deliver 240, 120, or 60 gpm, respectively. All of the pumps delivered the water at 800 psi pressure. Details of each pump are discussed below.

3.2.4.1 Quad pump (60 gpm) configuration: this was the pump design selected as the optimal configuration for the water-injection system design. Namely, four pumps to supply water to the four engines. The determining factor in the selection of this pump was the light weight (29 lb) and the low power requirements (37 kW), which would lead to more manageable current in-rush levels.

This pump design (fig. 24) was based on the heritage Argo-Tech aircraft water-injection pump model number 60273–8 for the Boeing 747 water-injection system. The pump is a multistage centrifugal-type design with a total of two stages to generate the rated pressure of 800 psi. An inducer is employed to lower the net positive suction head (NPSH) requirement and improve the altitude performance. In order to reduce the weight, a two-pole motor is used to drive the pump at high rotational speed. Depending on the flow and pressure regulation requirements, additional flow or pressure regulating valves may be used in the discharge or bypass lines.

The pump has a terminal block for connecting the three-phase wiring for the pump motor. The water outlet of the pump is located around the outside of the electrical motor and provides some cooling action.

3.2.4.2 Dual pump (120 gpm) configuration: This pump scheme was not selected due to the higher in-rush current that it would experience, which would overcome the capability of the aircraft electrical system.

The pump configuration (fig. 25), where two pumps supply water to the four engines, incorporated a two-stage centrifugal impeller was simple, had low relative weight, and had high-speed capability. The two-stage design allows for maximizing efficiency. An inlet inducer is provided to allow a minimum inlet pressure of 10 psia. The approximate pump characteristics are as follows:

Pump		Electric Motor	
Impeller diameter	4.3 in.	Output power	89 hp (66 kW)
Efficiency	63 percent	Efficiency	88 percent
Input power	89 hp	Input power	75 kW
Weight	25 lb	Weight	70 lb
Output pressure	800 psig	Power factor (full)	76 percent
Inlet pressure	10 psia	Full-load current	286 A
Flow (max.)	120 gpm	Starting (in-rush) current	1100 A

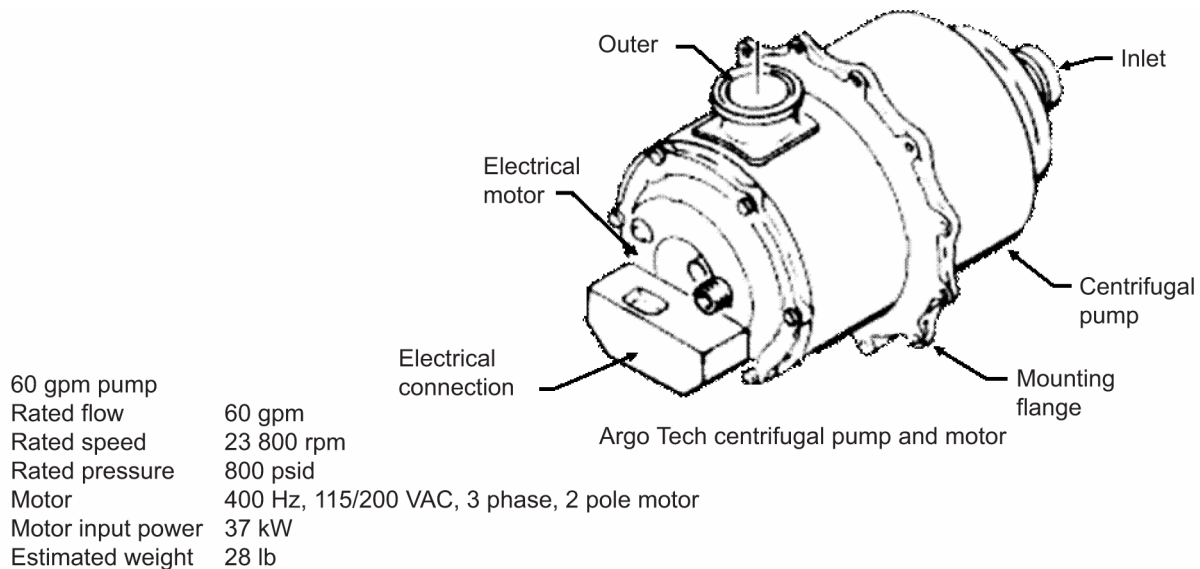

Figure 24.—The 747 water-injection single pump used for study.

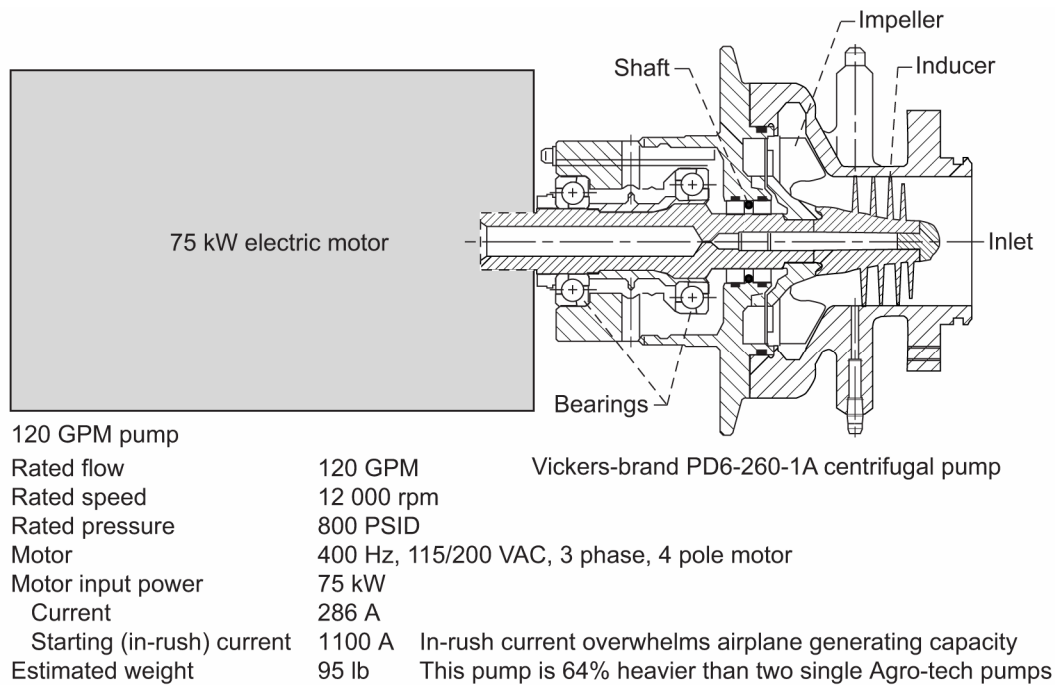

Figure 25.—Dual pumps were also evaluated but not pursued due to high in-rush current.

3.2.4.3 Single pump (240 gpm) configuration: This pump configuration would have had a single pump supplying water to the four engines. It was not selected due to very high in-rush current and also high motor weight.

A four-pole motor driving a two-stage impeller at 11 000 rpm and a two-pole motor driving a single-stage impeller at 22 000 rpm were both considered. However, both pump motors would require about 147 kW (197 hp) of electrical input power requiring 430 amps per phase. In-rush current to this motor would overwhelm the 747 electrical supply system. In addition, the weight of the electric motor alone was

estimated to be in the 200 lb range. For this reason, the single electrically driven pump configuration was abandoned.

Other single-pump design options might be for a hydraulic or pneumatic-driven motor. These options might provide lighter weight systems and should be further explored before any design configuration is finalized.

3.2.5 Electrical System.—The aircraft’s electrical supply system plays an important role in the design of the water-injection system. Namely, there must be enough surplus electrical power available on the aircraft to drive the water-injection pump motor(s) during takeoff.

There is a tradeoff to the system water pressure and electrical power requirements that must be considered in the system design. High water pressure will assure good atomization and distribution of the water inside the engine’s combustor. However, the power (fluid horsepower) required to drive the system is dependent on the pump’s pressure and flow rate (eq. 3.1), therefore a higher pump pressure will require a larger electrical drive motor.

$$\text{Power (F hp)} = \frac{P(\text{psi}) \times Q(\text{gpm})}{1714} \quad (3.1)$$

The minimum system pressure deemed acceptable for proper atomization was 300 psi higher than the engine’s combustor pressure. This resulted in a system pressure of 800 psig. Assuming a 53 percent conversion efficiency (which was supplied by the pump manufacturers) between electrical (kW) power and fluid (hp) power, a peak electrical power of 137 kW was required to drive the four water-injection pumps. This peak power draw would occur during the takeoff and initial climbout phase of flight for approximately 90 seconds as shown in figure 26.

The next step was to see if the aircraft could supply this level of electrical power. There are four integrated drive generators (IDG) on the 747 aircraft that supply power to four electrical buses. These four IDGs have the capability to provide excess electrical power to the aircraft. Therefore, should one of the IDGs become inoperative, the aircraft can still operate safely and can even continue to be dispatched from the airports until a reasonable time can be found to repair the inoperative IDG. Figure 27 shows the normal peak electrical loads for each bus on the aircraft during takeoff and climbout. It shows that this load requirement falls below the three-generator capacity and far below the four-generator. When adding the 137-kW electrical power requirement to the existing aircraft loads, one can see that this new level fits within the four-generator capacity level.

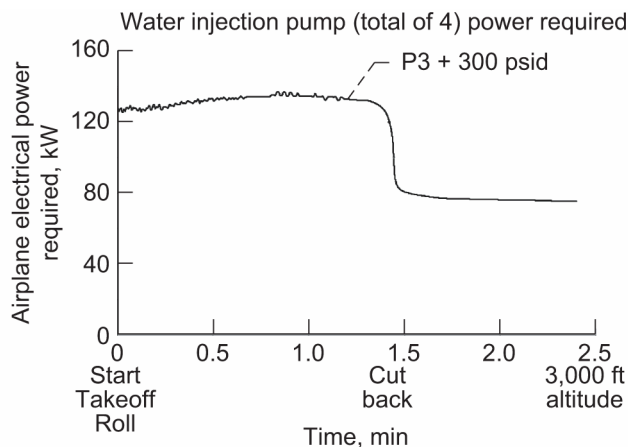

Figure 26.—The 800-psig pumps require a lot of electrical power to drive them.

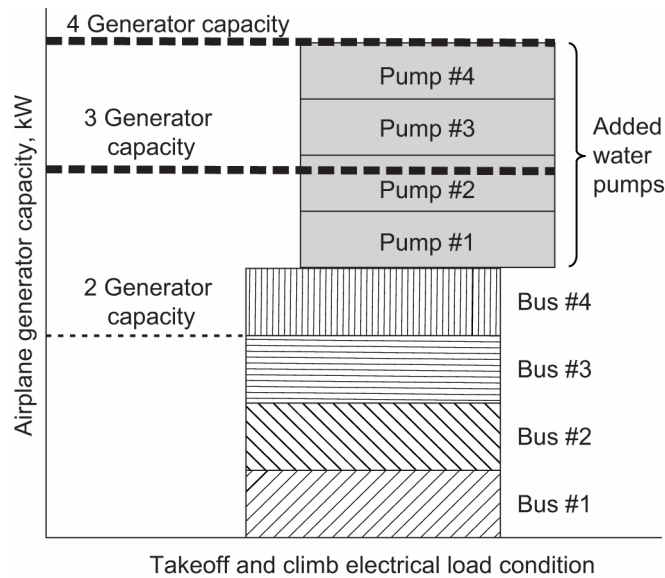

Figure 27.—Pumps could be powered by four generators but could not be used in three-generator dispatch mode.

The steady-state electrical power draw from the four pumps falls just within the capability of the aircraft. However, when starting each pump, there is a sudden current in-rush that could overwhelm the electrical system capability. Therefore, it is envisioned that there would be a timed phase-in of each pump's startup. For instance, pump numbers 1 and 2 might be started simultaneously. Pump number 3 would start next, followed closely by pump number 4. If peak power requirements were still exceeded, then another aircraft electrical load, such as galley(s), could be temporarily shed for the 2.4 min that water-injection system is operating.

3.2.6 Water Refill System.—Another issue needing to be resolved is how to quickly fill the water tanks while also reducing the chance of untrained personnel possibly refilling the water-injection system with contaminated water, which could quickly ruin the engines. Section 3.3.3 discusses the water quality requirements in more detail.

A water service panel was designed to be located as near the water tanks as possible to reduce weight of the refill lines inside the aircraft. Figure 28 shows that the panel is located on the left side of the aircraft just aft of the main wing box spar, which is directly under the water tanks. A water service access door is designed so that the ground service personnel can open the door to reveal the refill port. A water gage is provided to assure the service personnel that the tanks are indeed full when serviced with 400 gal of water. A drain switch and light are also provided. This switch will activate the aircraft's drain valve so that water can be offloaded through the fill valve by the water service truck. A check valve is incorporated into the fill valve so that water cannot accidentally be drained unless the hose is connected.

Figure 28 also shows an example of what a (conditioned) water service truck might look like. Depending on the height of the aircraft and the access panel, some aircraft might require that the service personnel be lifted up to the service point.

The water refill system should provide a system pressure of 30 psig (at the service panel) and a flow rate of 100 gpm. This will allow the water tanks to be refilled in 4 min. A specialized water service truck, or filling station, was envisioned to fill the airplane while parked at the terminal gate. The equipment would contain a tank for the demineralized water, pump, hose, refill nozzle, and water contamination sensor(s). The fill equipment and airplane system concept are shown in figure 29. The sensor(s) make sure that the pump would not operate when water does not meet the purity requirements.

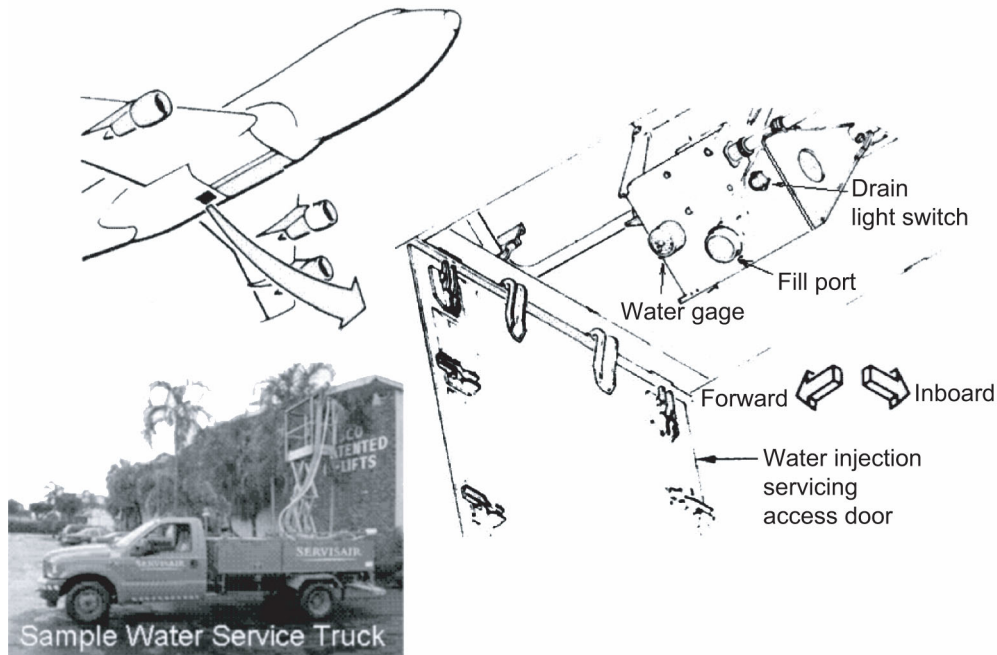
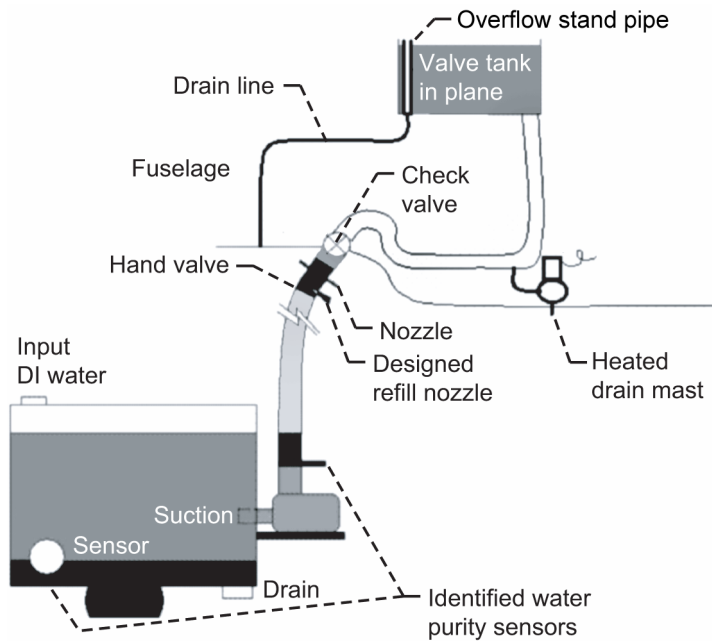

Figure 28.—Airplane is serviced with demineralized water.



*University of Colorado under contract to Boeing

Figure 29.—Water-injection tank refill system was preliminarily designed and tested.

Another device that helps assure the airplane is not filled with tap water is to construct a special water fill nozzle as shown in figure 30. This fill nozzle should be constructed with a unique quick-disconnect-type feature to facilitate quick servicing while also assuring no other type of water nozzle could be accidentally attached.

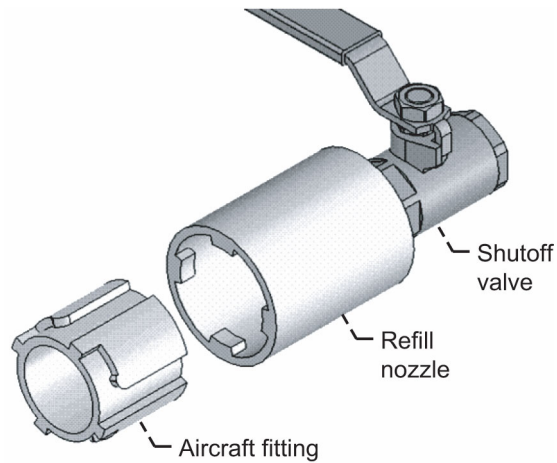

Figure 30.—Water refill nozzle needs to be specialized to prevent system from being filled with tap water.

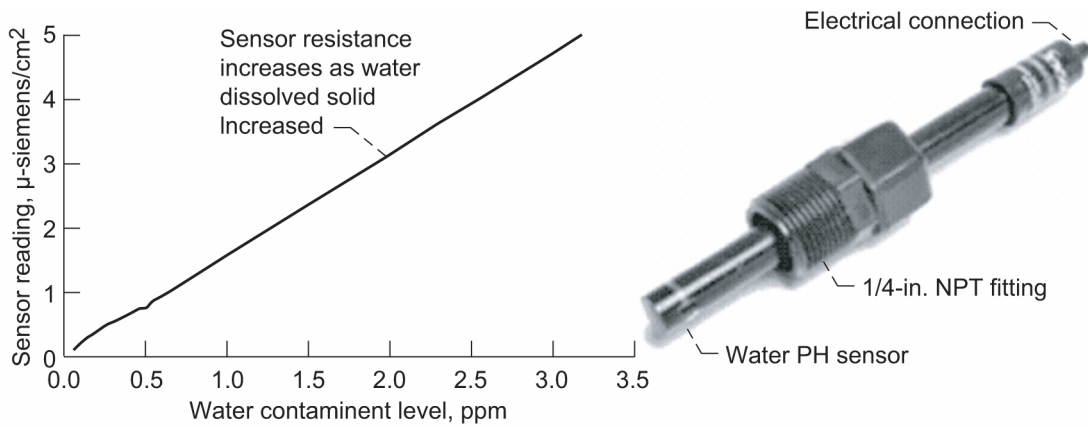

Figure 31.—Water-injection system purity sensor prevents contaminated water from entering system.

The water refill system also contains a water contamination sensor(s) to make sure water quality meets the minimum specification that will be discussed in section 3.3.3. These sensors are commercially available devices that register changes in electrical resistance with water purity, as shown in figure 31.

As discussed in section 3.4.9, some airports are so traffic constrained that they could not tolerate additional traffic operations on the ramp to refill the airplane via a water service truck. In these instances, a dedicated water supply hose would be provided at each terminal gate. A central conditioning unit could then supply demineralized water throughout the airport at each gate, where the refill hose would still have the special quick-disconnect fitting.

A water refill system, as shown in figure 29, was constructed and tested, outside of this contract, with various purity levels of water. Appendix B shows more detail on this work.

3.2.7 Strut.—The strut, or engine pylon, is the structure that attaches the engine to the wing. It also serves as a conduit for the many tubes and wires that run between the engine and airframe. The water-injection system’s tubes and wires also need to transition through the strut. The largest item for the water-injection system is a 1.25-in. OD water delivery pipe. For a new airplane, this pipe could be designed relatively easily into the new strut. However, for a retrofit or current production airplane, it would need to fit around the existing hardware. This will be challenging but most likely possible.

The largest items running through the strut are the bleed ducts (fig. 32) that carry compressed air from the compressor to the Environmental Control System and wing anti-ice systems.

Other tubing that runs through the strut are the fuel feed line, the hydraulic supply lines, and the fire extinguishing lines as shown figure 33.

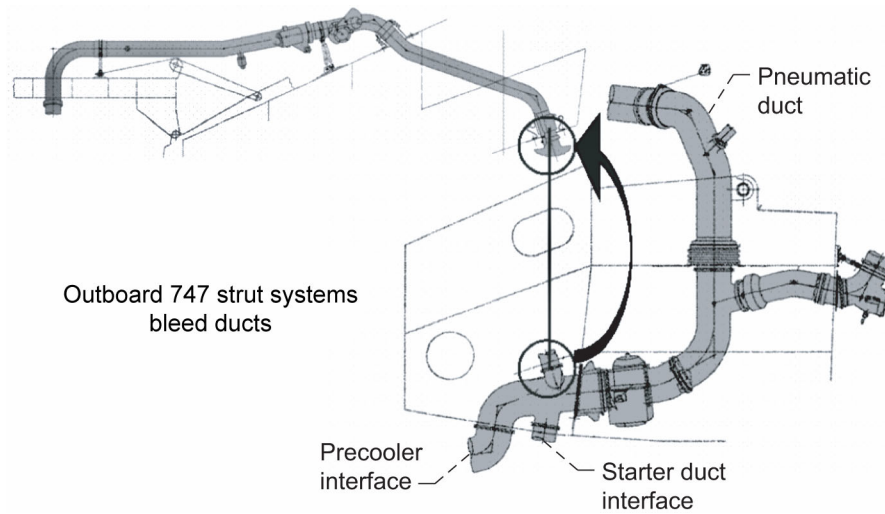

Figure 32.—Bleed ducts are the largest pipes contained in the engine strut.

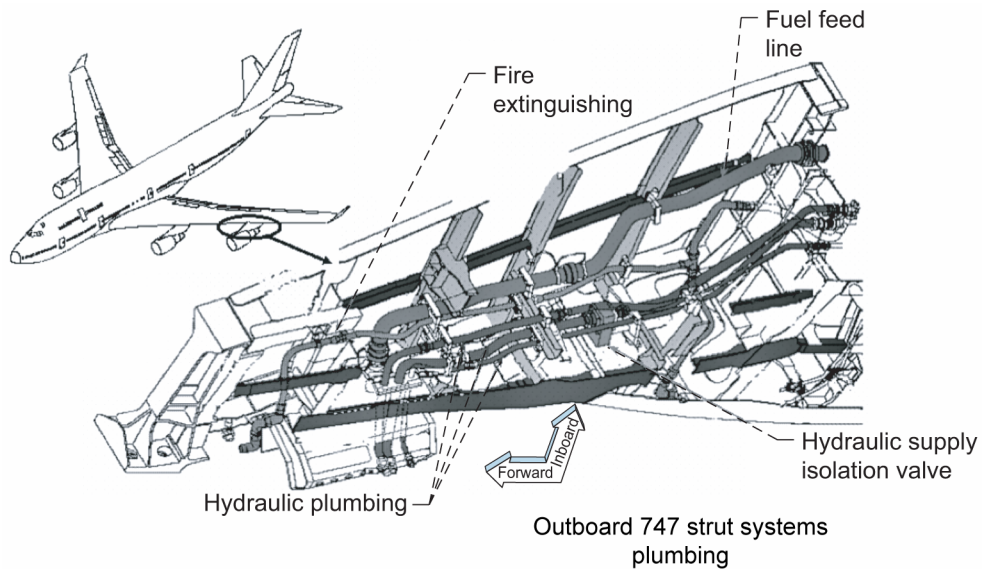

Figure 33.—Routing a 1.25-in. OD water supply tube through strut could be challenging as there are already many tubes.

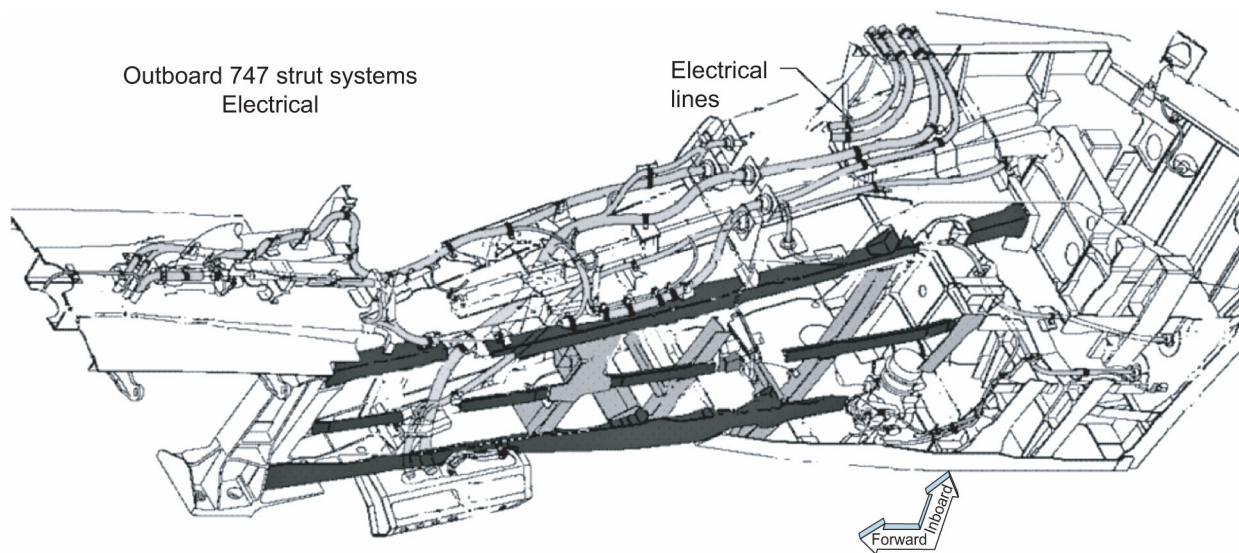

Figure 34.—Electrical lines also take up room in the strut and make a water-injection line installation more difficult.

Lastly, there are several relatively large diameter wires running from the IDG to the airplane's electrical bus (fig. 34). For a retrofit or current production airplane scenario, the single 1.25-in. OD water-injection tube would either have to be routed around all of these existing items, or they will have to be moved to a new location. This could become especially problematic and expensive for the retrofit case since it would require more engineering design effort and also replacement of perfectly good tubing lines and wires that are in service.

The best case for water-injection installation in the strut is for a completely new airplane design so that no existing systems would have to be reengineered.

3.3 Engine System Design

There are several methods of introducing water into gas turbine engines, but the two that were studied for this report were direct combustor water injection and atomization of water in front of the low-pressure compressor, or water misting. From a previous study (ref. 1), these two methods appeared to offer the best performance options. The combustor-injection system was focused upon due to fewer associated issues with compressor surge margin deterioration, as will be discussed in section 3.4.

3.3.1 Compressor Injection (Water Misting) System Design.—This type of system consisted of injecting finely atomized (i.e., 5 to 10 μm) water droplets into the inlet of the LPC, and possibly into the HPC as shown in figure 35. It was assumed that this system would have the same design layout as aeroderivative industrial gas turbine engines. As some of these engines are limited by the compressor discharge temperature in lieu of the turbine inlet temperature, the water misting system can allow for moderate increases in power (e.g., 12 percent) at standard day conditions and more (e.g., 30 percent) on a 90 °F day.

High-pressure air is bled off of the HPC to assist in atomizing the water in the many water-injection nozzles. This HPC air reduces the level of water pressure needed to atomize the water and therefore reduces the level of electrical power needed to drive the water pumps.

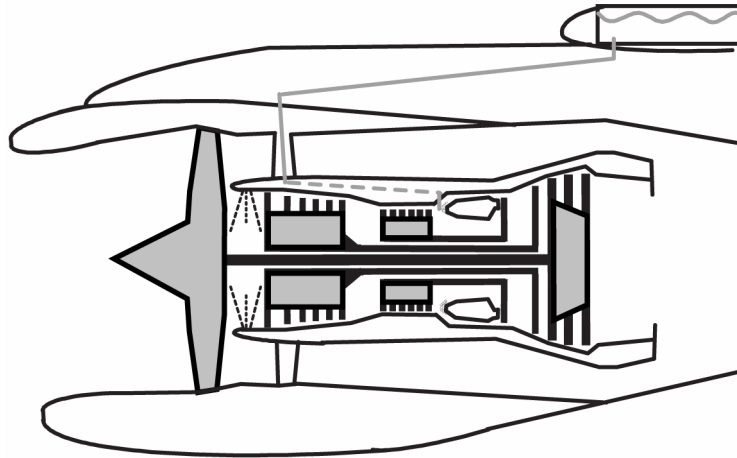

Figure 35.—Water misting concept that would spray atomized water in front of the low-pressure compressor.

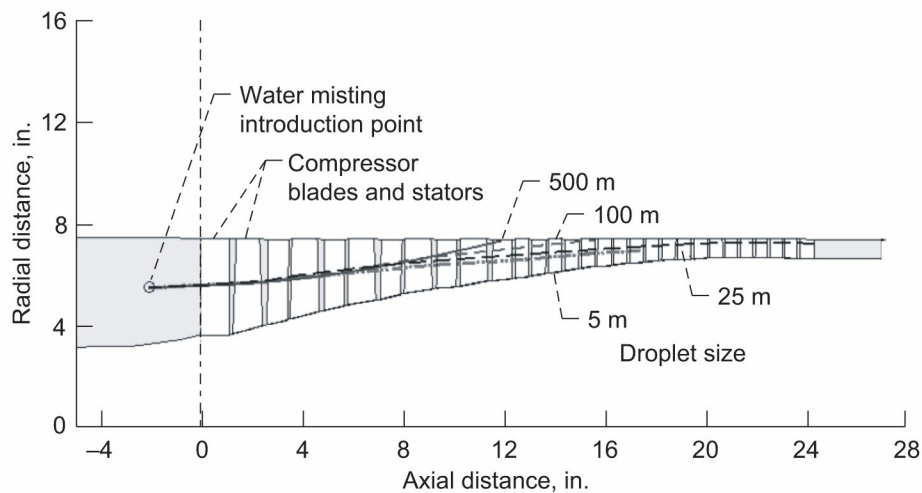

Figure 36.—Water droplet size needs to be sufficiently small to avoid being centrifuged to the outside of the engine case (ref. 4).

It is important that the injected water droplets are sufficiently atomized to avoid their being centrifuged to the outside of the compressor and impacting on the engine compressor case. Figure 36 shows an analysis that predicts water droplets larger than 25 μm diameter will be thrown outwards towards the engine case (ref. 4). Here they will produce the same effects as the older water-injection systems used on the original 747s—the engine case will thermally distort and will also cause blade tip clearance problems.

Another important factor for the water misting system is that the atomized water droplets need to be introduced sufficiently far upstream of the LPC to allow them to evaporate. The larger the water droplet, the longer it will take to evaporate. Figure 37 shows that a 5- μm -diameter water droplet will completely evaporate within 17 in. of entering the LPC. Large droplets take significantly longer.

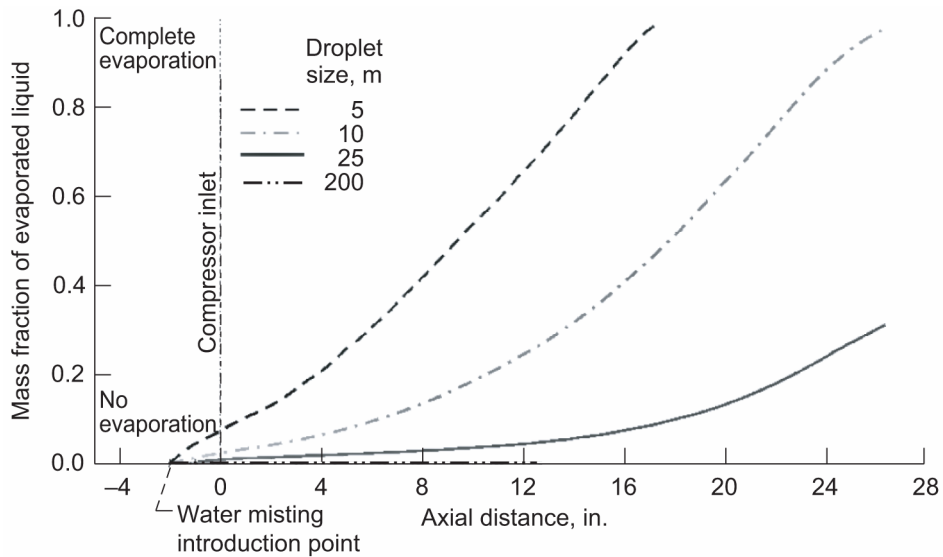

Figure 37.—Larger droplets, or those very close to the LPC, do not evaporate completely.

The evaporating water droplets will cool the compressor inlet air. This cooling effect can result in an engine performance improvement. The performance improvement is similar between operating an engine on a hot day versus a cool day. When a 2.2 percent water-to-air (engine core) injection ratio is achieved on a 69 °F day, a 3.51 percent improvement in SFC is predicted (ref. 1).

The previous water injection feasibility study (ref. 1) reported that this system could deliver larger turbine inlet temperature reductions than the combustor injection system. This is because of the larger amount of water required (480 gal for 50 percent NO_x reduction versus 400 gal for 80 percent NO_x reduction on water injection) a slightly improved SFC, and more derived thrust. This study will validate those results in section 3.4 and report on findings from Pratt & Whitney.

As high turbine inlet temperatures (T41), usually associated with high ambient temperature conditions, clearly result in more frequent hot-section repair intervals. This water-misting system was originally the favored option at the start of this study. However, as will be seen in section 3.4.4, the modeled loss of compressor surge margin with this system (fig. 56), and the high weight of the larger amount of carried water shifted the focus of the study to the combustor injection scheme described below. A detailed system design was therefore not carried out.

3.3.2 Combustor Injection System Design.—This method routes high-pressure water through a distribution manifold that runs around the engine case and then into several dual water/fuel nozzles that spray the conditioned water directly into the combustion chamber.

Figure 38 illustrates a concept that is typically used in industrial gas turbine engines. This method eliminates the water distribution problems that were seen in the earlier water-injection systems used on Boeing 747 aircraft engines. Namely, water, or the water-cooled air, will neither impinge on the engine case nor run down the combustor walls to cause combustor thermal stressing. When properly atomized by the fuel nozzle, the water will not contribute to the same pattern factor problems associated with earlier engines.

There are several different design types of water-injection nozzles in use. A common theme is to integrate the water passage along side the fuel passage in the feed stem. Some nozzles eject water directly through plane orifices located in the tip of the fuel nozzle spray head, while others may spray water into the nozzle swirl vanes as shown in figure 39.

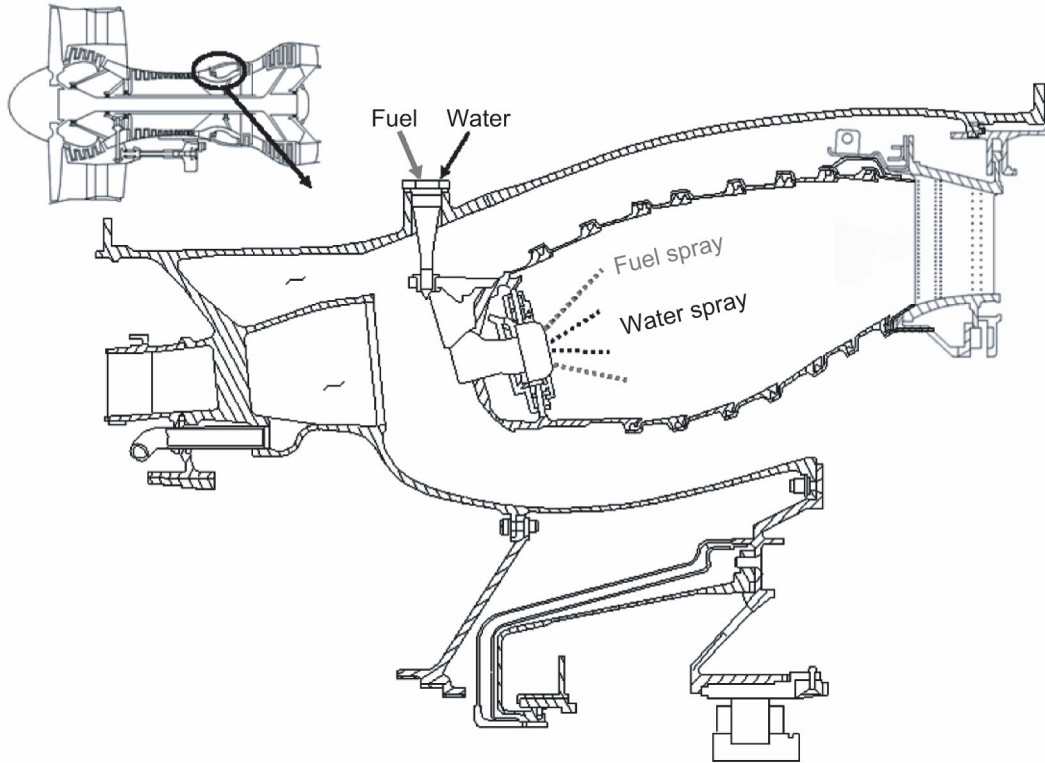

Figure 38.—Concept showing the new industrial water-injection system that sprays water directly into combustor to avoid previous problems.

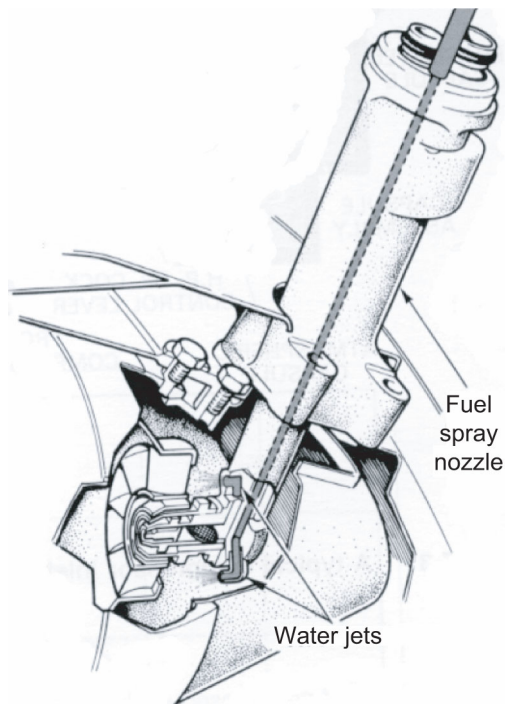

Figure 39.—Some water-injection nozzle spray water into the swirl vanes (ref. 5).

When water is sprayed into an engine, and the power setting is held constant, the flame temperature in the combustor decreases. Figures 40 and 41 show the effect water injection has on flame temperature in a CFD model and an actual test rig of an experimental trapped vortex combustor (TVC) at the Air Force Research Laboratory (ref. 6). The pictures on the left of both figures show the baseline TVC. They illustrate the high luminescence and corresponding high thermal radiative loads of a combustor operating under simulated engine conditions. The photographs on the right show the same combustor operating with a water-to-fuel injection ratio of 1:1. The photograph in figure 41 gives one the visual clue that a large reduction in thermal radiative loading has been achieved. It also shows downstream in the combustor throat, that the flame has not been extinguished, but has simply been turned into the blue flame that is so sought after by combustion engineers.

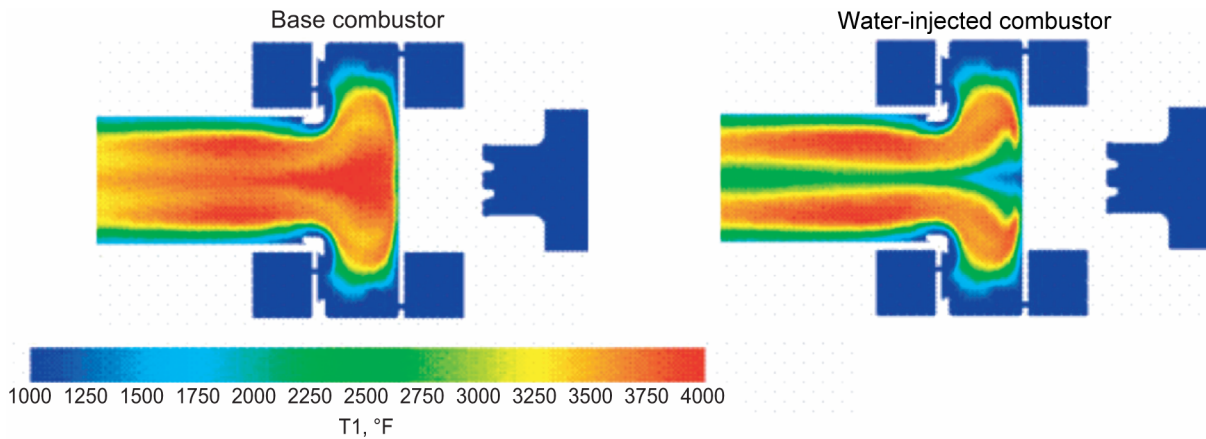

Figure 40.—CFD models of a trapped vortex combustor (TVC) showing flame temperature effects of a 1:1 water-to-fuel injection ratio.

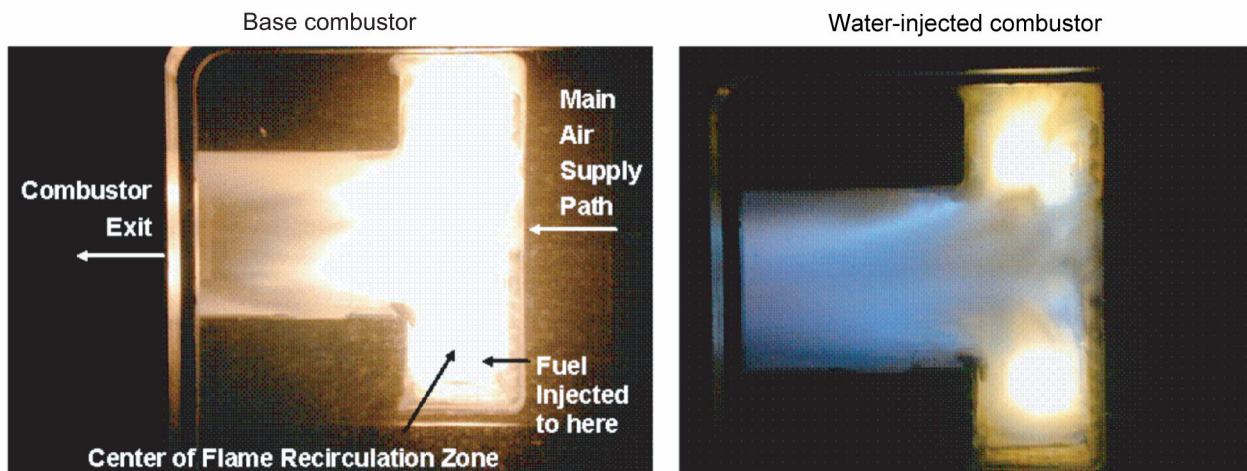

Figure 41.—TVC tests showing high-temperature baseline (left) and cooler 1:1 water-to-fuel injected combustor (right).

Two water-injection system design approaches are presented: one from Pratt & Whitney and one from Rolls-Royce plc.

3.3.2.1 *Pratt & Whitney System Design*: Pratt & Whitney was under contract to NASA to provide a water-injection design and performance estimates to Boeing (ref. 7).

The Pratt & Whitney water-injection design used a dual fuel/water nozzle, somewhat similar to what was presented in figure 38 except that the water was mixed with the fuel prior to the nozzle and the combined mixture then flows through a common feed line which is then sprayed through a common orifice into the engine combustor.

There may be some problems with such a system (e.g., fuel nozzle is not optimized for fuel use only) for aircraft, but it represents a good starting point for this study as Pratt & Whitney has experience with this system for industrial gas turbine engines.

Figure 42 illustrates a Pratt & Whitney concept of the design for the water-injection system used for the study. However, it also includes a natural gas and steam injection circuit that was not considered for this aeroengine application.

One way that Pratt & Whitney overcame the design shortfall of this system was to optimize the nozzle for fuel flow only. When adding water during takeoff (doubles the total flow through the nozzle), the fuel pressure would then be increased in order to overcome flow resistance and allow the same amount of fuel to flow through the nozzle with the added water.

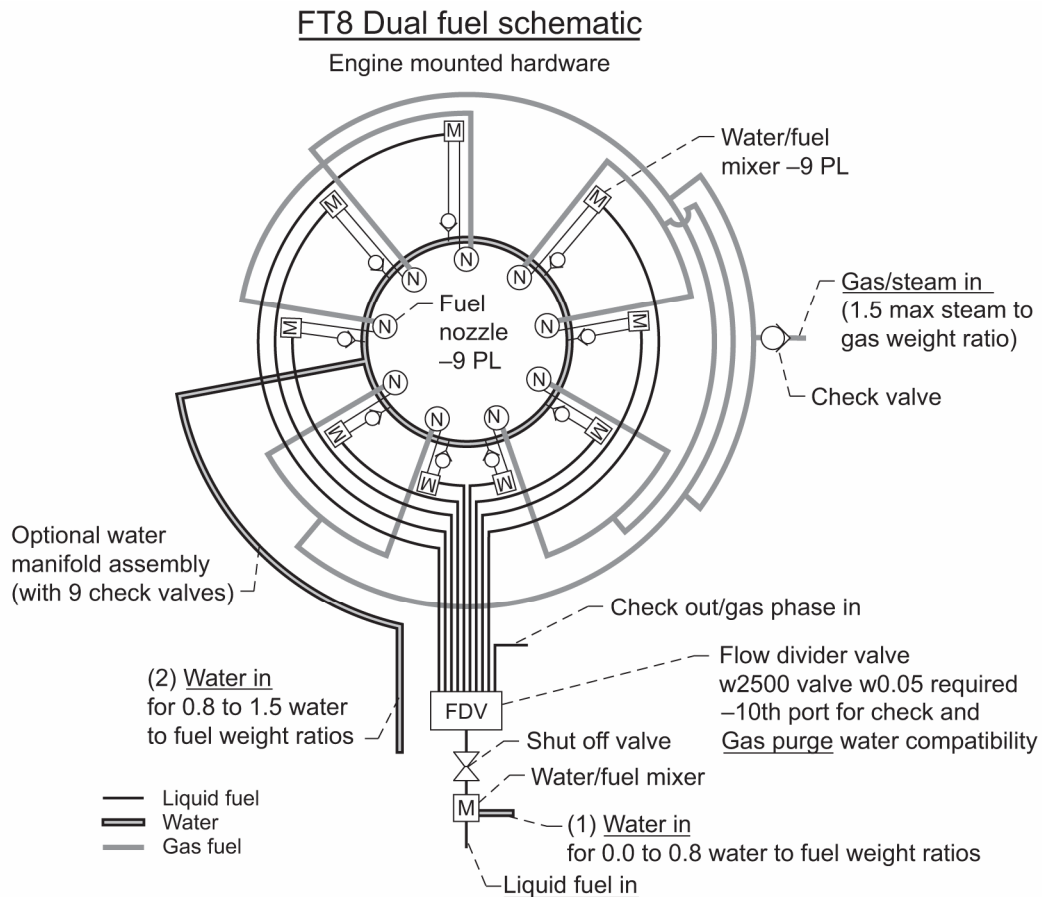

Figure 42.—Pratt & Whitney water-injection system concept.

A drawback to the added fuel pressure approach is that the fuel system then suffers a weight and cost penalty by increasing the fuel system pressure during water injection. As this weight penalty could about double the engine system weight, our study assumed that another method could be found to solve this weight penalty (such as the Rolls-Royce system shown in fig. 39). Pratt & Whitney quoted an engine weight estimate of 16.1 to 31.9 lb per engine for the water-injection system alone. The fuel pressure penalty would add 21.0 to 29.6 lb more per engine. As will be shown in section 3.4.1 we used 31.9 lb per engine for the airplane weight assessment.

As water injection can supply 10 to 30 percent more thrust, a control logic algorithm needs to be implemented within the engine digital electronic controller to tell the engine that the water-injection system is indeed operating and to adjust the fuel flow schedules accordingly.

3.2.2.2 Rolls-Royce System Design: Rolls-Royce plc also provided design concepts for an aircraft water-injection system. They first assessed where to mount the water pump and how to drive it. The following three designs were considered: (1) an air turbine water pump, (2) a case-mounted water pump, and (3) an airframe mounted pump, which are now discussed.

The conceptual design of an air-turbine-driven water pump system is similar to what is used on the Pegasus engine for the Harrier military aircraft (fig. 1). In this configuration, high-pressure air is bled off the engine compressor and fed to a pneumatic motor, which is attached to the water pump. In this configuration (fig. 43), the HPC bleed air is taken from the anti-icing system for the engine nacelle. This air is fed through a pneumatic control valve, located on the engine core, to the air turbine water pump. A low-pressure water boost pump is located on the water tanks in the airframe. This supplies water at about 30 psig to the high-pressure air turbine pump. The water is then pressurized to about 800 psig in the pump and fed to a water distribution manifold where it will be injected through a dual water/fuel nozzle, similar to what was presented in section 3.3.2.

The benefits of such a system are that no electrical supply limits for the pump motor will be encountered. This system also has the potential for being quite lightweight as pneumatic motors can be substantially lighter weight than electrical motors. The water feed lines from the tank to the engine can also be made lighter weight since they are operating at a lower pressure.

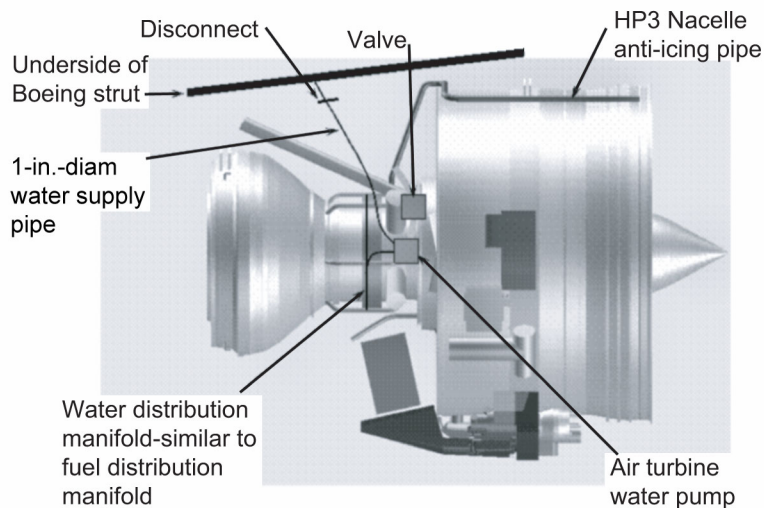

Figure 43.—An air-turbine-powered water pump for water injection was the first option studied.

The disadvantages are that the high-pressure bleed lines would need to be redesigned. In addition, the air exhaust from the pneumatic motor would need to be routed into the fan bypass duct. It is uncertain how this might affect the operation of the engine fan. Also, these types of pneumatic motors tend to be quite noisy, so the exhaust would most likely need to be muffled or the takeoff noise level of the entire aircraft might increase.

Another option would be to mount the water pump directly onto the engine's gearbox as shown in figure 44. This would eliminate the air exhaust noise problems and the need to redesign the bleed system.

In this configuration, the water line would need to be routed around the engine fan to the pump, which would be located on the accessory gearbox, also on the fan case. From there, the water line would be fed through the lower bifurcated duct panel up to the water distribution manifold.

This design approach also presents challenges. Namely, it could only be used on a newly designed engine as there are no current spare pads on the accessory gearbox to mount the water pump. In addition, the 1-in.-diameter pipe would be difficult to feed through the lower bifurcated duct passage. Lastly, the pump would either need to be disconnected via a heavy clutch mechanism, or be run continuously.

The last configuration involved mounting the water pump on the airframe and feeding the high-pressure water to the engine. As shown in figure 45, this is the simplest system for the engine. A 1-in.-diameter pipe (1.25 in. diam would have less pressure drop and was used on the airframe side) is fed through the strut to the engine core where it is attached to the water-distribution manifold. The water flow control valve would be located in the strut or wing and controlled via the engine electronic control module. The control module would gradually introduce water to the engine to avoid thermally shocking the engine hot section. There would also be a drain valve and drain line (not shown) that is connected to the water manifold, which runs down through the bifurcated duct panel and out the bottom of the engine.

For this configuration, there would be minimal changes to the engine and no issues are envisioned. Thus, of the three configurations studied for the Rolls-Royce water-injection system, the airframe mounted water pump was chosen as the preferred configuration.

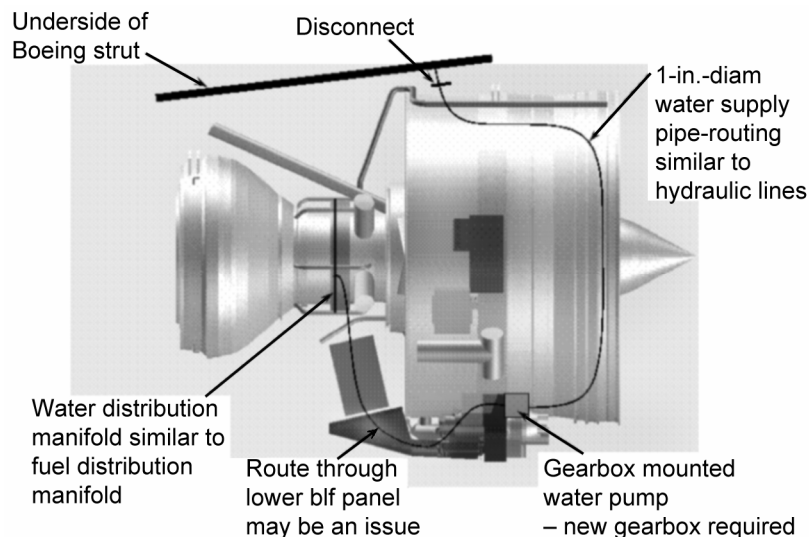

Figure 44.—A case-mounted water pump for water injection was the second option studied for one engine.

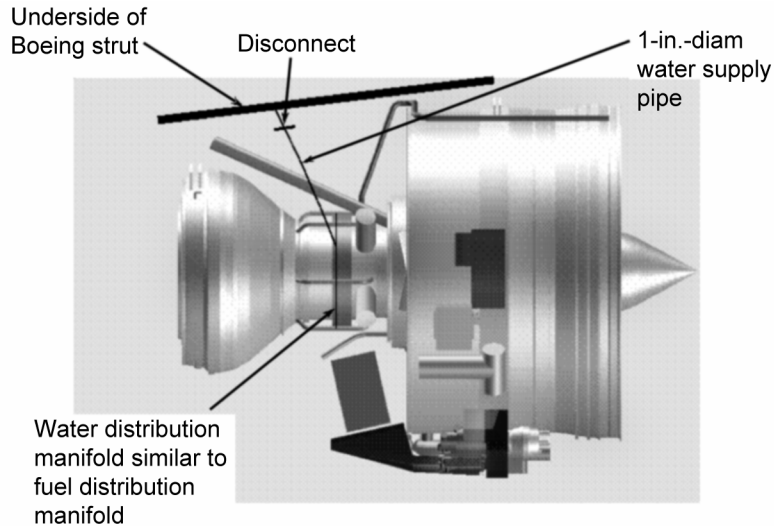

Figure 45.—An airframe-mounted water pump was the third option considered.

3.3.3 Water Purity Requirements.—In order to avoid damage to the engine hot section, demineralized water must be used in the water-injection system. The level of required water purity varies between engine manufacturer, and is listed for Rolls-Royce industrial gas turbine engines in table VI.

TABLE VI.—WATER QUALITY REQUIREMENTS FOR WATER-INJECTED ENGINES

The sample of fluid must be obtained using ASTM method D.3370 for water.				
The water must be clear in appearance.				
The quality of the water must generally conform to ASTM D.1193 type IIIA or IVA and have the following properties:				
Parameter	Units	R-R Specification Limits	ASTM Method	Other Engine
Total matter	ppm max.	2	D.1888	10
Dissolved matter	ppm max.	0.5	D.1888	5
pH value		6 to 8	D.1428	?
Sodium and Potassium	ppm max.	0.2	D.1293	0.1
Silica	ppm max.	0.05	D.859	?
Total hardness	epm max.	0.2	D.1126	?
Conductivity at 25 °C	microS/cm max.	1	D.1125	?
Max. particle size		10 μm	N/A	20 μm
Biological contamination			F.60	?

The Rolls-Royce water quality requirements are significantly more stringent than for other water-injected engines. The purity level listed for other engines is considered more easily attainable and can be achieved with relatively conventional equipment (ref. 8).

As the aeroengine will only use the conditioned water for less than 3 min and the industrial engines use the water continuously, it remains to be seen if these types of quality requirements are needed for aeroengines. If water injection were to be implemented, a trade study should be conducted to evaluate the impact of lesser quality water on engine durability versus the cost of conditioning the water.

3.4 Performance Summary

The water-injection system will affect the performance of the airplane and the engines. The water-injection system will add weight, increased power demands and complexity to the airframe, which will have an adverse impact. The same is true for the engines, except that water injection will have a greater impact on their operation—some adverse and some beneficial.

3.4.1 Weights.—By their vary nature, airplanes are very sensitive to weight. When adding the water-injection system to the airplane, even when it is empty of water, the airplane’s payload capability and range will decrease. On a retrofit case, this payload loss will be compensated for by reducing the number of passengers carried. For a newly designed airplane, the airplane’s payload carrying capability would need to be increased. Therefore, in either case, weight will be a critical issue to address.

The weight estimates for the water-injection system were broken down into airframe and engine components. In any of the installation concepts studied for the combustor water-injection method, the weight remained relatively unchanged for each of the systems.

Table VII shows the estimated weight breakdown for the airframe portion of the water-injection system. For all of the components, except the tanks, these weights were derived from the traditional 747–200 water-injection system. The tubing weight was increased as the previous aluminum tubes were replaced with CRES. However, the weight of this part of the system climbed precipitously. Therefore, the CRES tubing was replaced with titanium tubing, saving approximately 115 lb. This tubing weight variable includes fittings, mounting brackets, and special flex couplings in the wing, which explains the relatively high fraction of system weight.

As the previous water tank on the 747–200 was integral to the wing and the newly designed tank was placed below the cargo hold, the new water tank weight was estimated from composite construction guidelines.

The total weight of the airframe portion of the water-injection system was estimated to be 620 lb, which is heavier than the heritage water-injection system due to the improved design features just mentioned. Further improvements to this weight would be difficult to achieve.

TABLE VII.—WEIGHTS BREAKDOWN FOR AIRFRAME PORTION OF WATER-INJECTION SYSTEM ON A BOEING 747

Part	Weight (lb)
Pumps (four)	110
Tanks and mounting	175
Service panel	10
Ti plumbing	210*
Valves, etc.	40
Wiring	75
Total airframe	620
* For SS tubing, add 115 lb	

The water-injection system weights for the engine were supplied by Pratt & Whitney and modified by Boeing to account for an anticipated different architecture. As discussed in the Pratt & Whitney system description, that particular method of injecting water into the combustor employed a fuel pressure boost system. This significantly added to the engine system weight. As other engine manufacturers have eliminated this weight penalty by designing the system slightly different, this present study assumed the 21 lb per engine weight penalty would be able to be eliminated once the aeroengine system was optimized.

Table VIII shows the weight breakdown for each engine. The low weight column assumes an optimized water-injection system, while the high weight column provides the weight estimate given by Pratt & Whitney.

TABLE VIII.—WEIGHTS BREAKDOWN FOR EACH PW4062 ENGINE WATER-INJECTION SYSTEM

Part	Low Weight (lb)	High Weight (lb)
Tube from FMU to FDV	0.4	Same
Water flow meter	3.5	Same
Flow distribution valve	3.8	Same
Manifold and extensions	9.3	Same
Flow meter support	1.2	Same
WMU support	0.2	Same
Water manifold brackets	10.5	Same
Water mixers	0.3	Same
Fuel pump adder	None	21
Total	31.9	52.9

The total system weight used in this study was 748 lb. This consisted of the 620-lb airframe weight and 31.9 lb for each engine, or 127.6 lb for all engines.

This amount of weight increase is a serious issue and will no doubt be met with strong objections from the engineering community. However, one approach to address this (for newly designed airplanes anyway) would be to slightly increase the payload capability of the airplane in the design phase. For retrofit applications, this is not possible, therefore, the payload loss issue will need to be addressed with the airline operators.

3.4.2 Structures.—There are several structural design issues with the system that will need to be addressed. As shown in figure 46, these have to do with the water tanks and water lines.

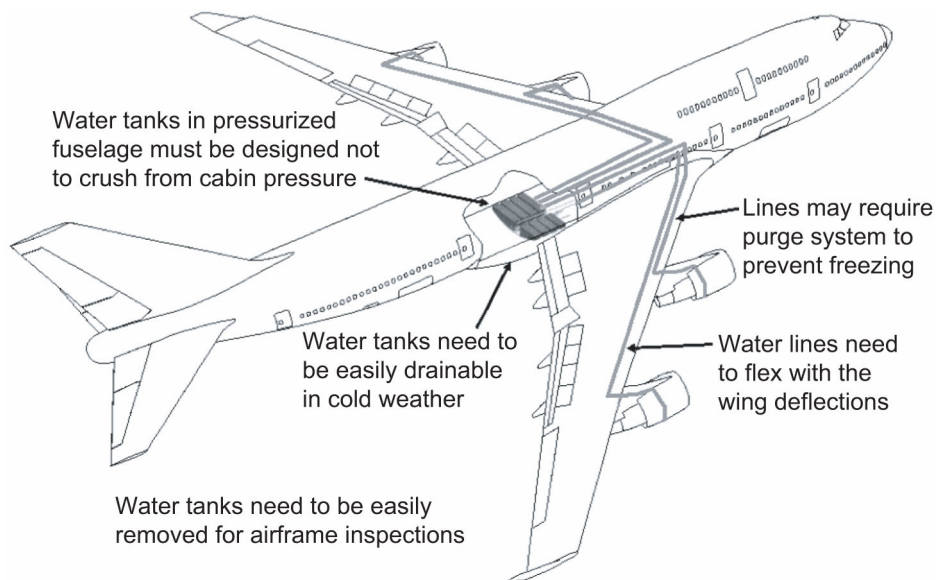

Figure 46.—Several structural requirements need to be addressed.

The heritage water-injection system had the water tanks located in the unpressurized part of the aircraft and, therefore, did not have to deal with pressure differentials within the tanks. As the new tanks are located inside the aircraft pressure vessel (to eliminate freezing problems) and the water lines need to be drained to atmospheric pressure, the tanks could collapse if the drain lines equalized the internal tank pressure to ambient. Therefore, either the tanks need to be constructed to withstand that type of pressure differential, or the drain and vent lines need to have shutoff valves installed to the outside and the tanks vented to the cabin pressure.

Another tank design issue that needs to be addressed is the ease with which they can be removed for airplane inspection. Namely, the airframe is periodically inspected for corrosions, cracks, etc., and the tanks would need to be removed to gain access to the bilge area of the aircraft.

The water tanks and fill lines need to be designed such that they can be completely drained of water as they could still be subjected to freezing conditions. For example, the aircraft could be serviced with water and the flight then cancelled in freezing conditions. If the cargo hold door were to be left open, the water in the tanks and fill lines could then freeze. As 400 gal is a sizeable amount of water, it could not be drained through the heated drain mast onto the airport apron, but would need to be offloaded via the water service truck.

Similarly, the pressurized water lines need to be drained after each use as they run through unheated parts of the airplane. The draining may be done via a gravity-feed-type system that utilizes antisiphon valves, or it could be done via high-pressure bleed air being introduced into the water supply lines to blow the water out through drain lines.

On larger airplanes, the wings can flex up and down enough that means must be made to allow the water supply tubing to also flex. Previously, this was done by flexible couplings on the tubing that was installed inside of the wing leading edge.

None of these issues are serious and can be addressed with good engineering prowess.

3.4.3 Testing Requirements.—The water-injection system will need to be tested for functionality, operational durability, and certification requirements as shown in figure 47.

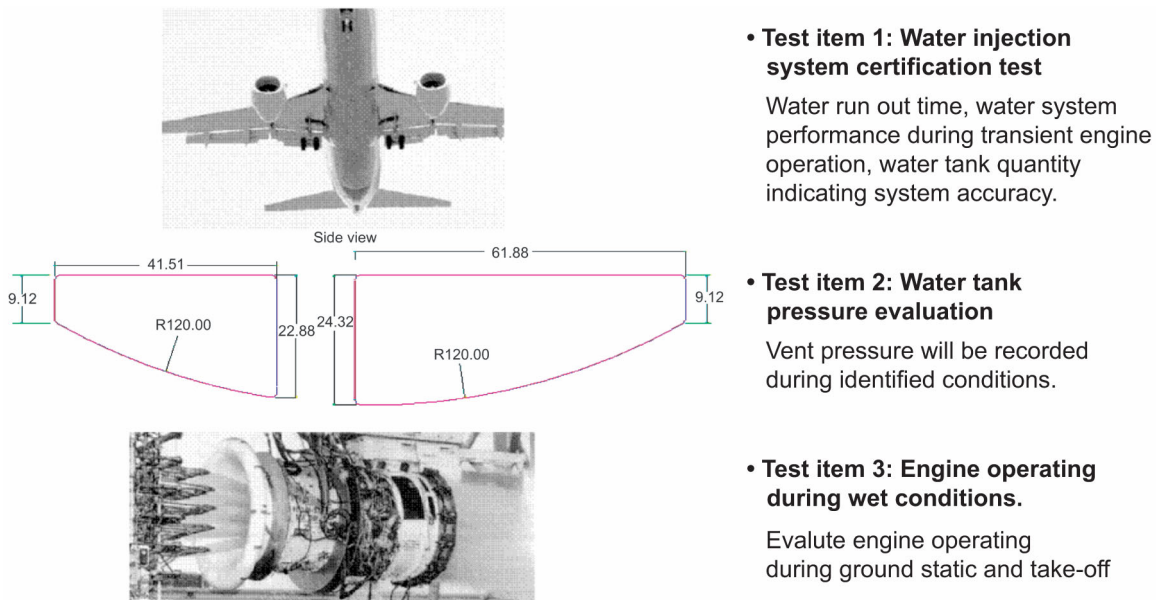

Figure 47.—Airframe and engine water-injection systems both will need to be tested and certified.

For the certification tests, the airplane system will need to demonstrate operability and performance under simulated and actual conditions that the airplane will encounter. Some of the items that need to be addressed in the testing are the system must respond accurately during engine transient throttle changes, control of the water-injection rate meets requirements, the tank water quantity indication system accurately measures the water, and the water delivery system continues to be operational under various airplane attitudes.

The water tanks will need to undergo specific testing to validate its integrity and that the air pressures throughout the system are as expected so that the structural integrity of the tank is not breached.

The engine will also need to undergo operational tests to assure stable operation, especially during wet conditions and therefore will have to be subjected to a water-ingestion test when using water injection.

For a new airplane design, these tests will add some cost to the overall program as there would be an increased amount of work added to the already planned airplane tests. However, for a water-injection retrofit scenario, or adding water injection as an option to a current production airplane, these tests would add significant nonrecurring costs. This is because the tests would need to be conducted solely for the water-injection system and therefore would not share the testing costs with the airplane development program.

3.4.4 Engine Performance Impact for Water Injection.—Injecting water into the combustor showed less of an impact on compressor surge margin than water misting and yet achieved a worthwhile 120 °F reduction in turbine inlet temperature. A 1:1 water-to-fuel ratio was selected as the optimal ratio to reduce NO_x 80 percent and still maintain combustor stability. While holding a constant takeoff thrust, figure 48 illustrates the modeled results of water injection. As the water flow rate is increased, the engine spool speeds (N1 and N2), the compressor exit temperature (T3), and turbine inlet temperature (T4) all decrease.

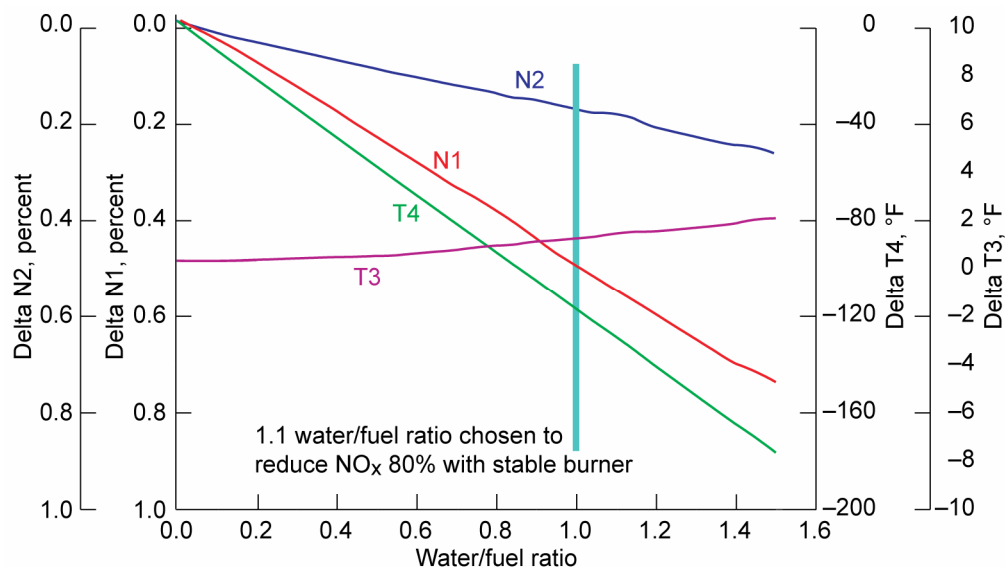

Figure 48.—Water injection directly into the combustor was modeled to provide a 120 °F reduction in T4.

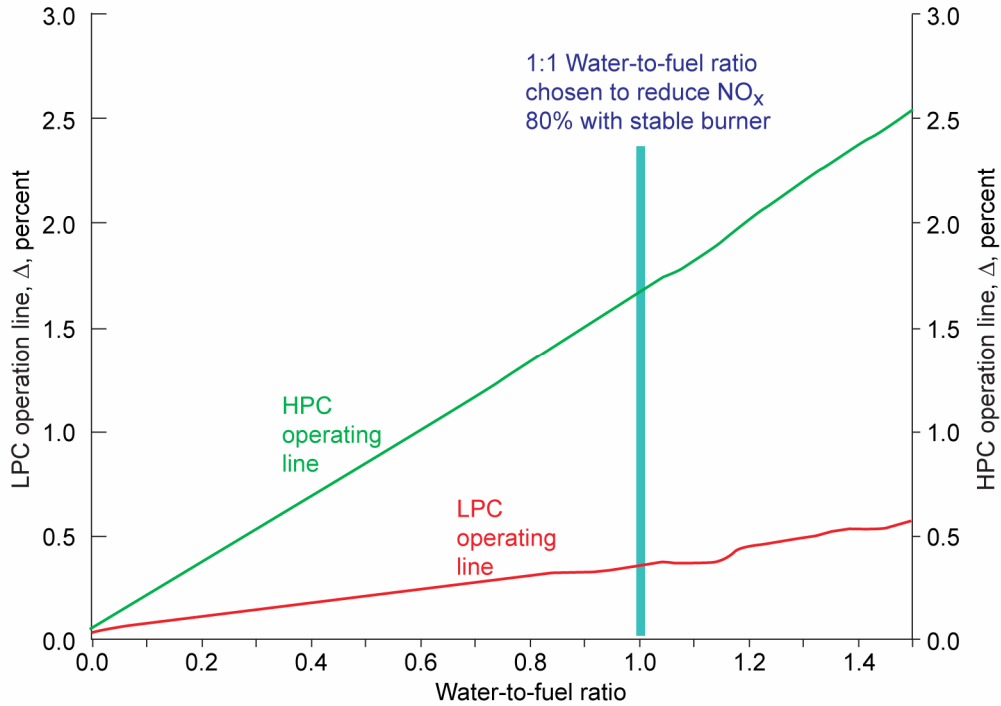
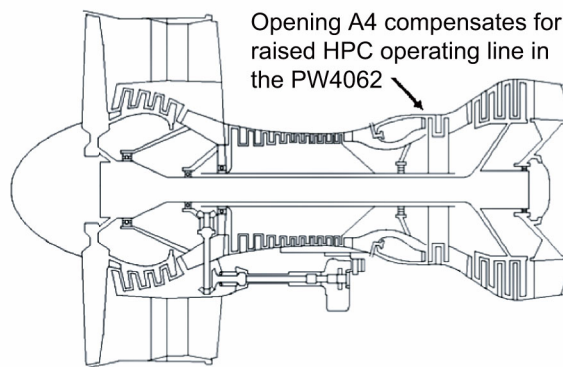

Figure 49.—Water injection resulted in LPC and HPC surge margin losses of 0.4 and 1.6 percent, respectively.



However, "...the turbine area re-match to maintain current HPC stall margin take-off would drive a 0.4 percent TSFC penalty at cruise"

Figure 50.—A turbine re-match would be required with water injection to correct for compressor surge and would result in a 0.4 percent SFC penalty for a retrofit engine.

The LPC and HPC showed less deterioration in surge margin than for LPC water misting. Figure 49 shows that at the optimal 1:1 water-to-fuel injection ratio, the LPC loses 0.4 percent in surge margin while the HPC loses 1.6 percent.

For some types of engines, this level of deterioration can be tolerated without further intervention. However, for other engines that are more sensitive to compressor surge, some action will need to be taken to resolve the issue.

To compensate for the loss in surge margin for the PW4062 engine, the high-pressure turbine would need to be opened up to rematch the new compressor flow rate with water injection. However, figure 50

shows that so doing will result in a 0.4 percent SFC penalty. For long-range airplanes that are very sensitive to engine fuel efficiency, this level of efficiency would be quite onerous.

However, for a new engine that is specifically designed around water injection, this penalty may be eliminated. This again suggests that water injection would be best suited for newly designed airplanes and retrofit options are less suitable.

The EGT coming out of the engine’s turbine is typically also used to control the operation of the engine. As the parts of a gas turbine engine wear and the performance begins to deteriorate, the EGT increases. Therefore, an upper limit is set for each engine at which time the engine must be overhauled to avoid over-temperature situations, which would damage the turbine blades. The difference between operating temperature and the limit is referred to as the “EGT margin.”

Figure 51 shows that when water injection is used during takeoff (for the PW4062 engine with rematched turbine), a 25 °F decrease in EGT is achieved, which will increase the EGT margin. This means that the engine can be operated for a longer period of time before overhaul, which could be of substantial savings for an airline operator. However, once the normal EGT margin is reached, the water-injection system would lose its “optional use” status and need to be operated at each takeoff to avoid turbine over temperature conditions. As this study considered the use of water injection as an option to the operator (to avoid any potential safety issues with a flight critical system), the cost benefits of the increased EGT margin were not considered in this study.

As the water tends to slightly quench the flame temperature in the combustor, there is an accompanying loss in thermal efficiency of the engine when water injection is used during takeoff. Figure 52 shows that during takeoff, there is a 1.2 percent increase in fuel consumption when water injection is used.

This thermal efficiency loss is reflected in the decrease in combustor exit temperature. This temperature is shown in figure 53 and is slightly higher than T41 turbine inlet temperature for the takeoff profile of the 747–400ER aircraft. During takeoff and climbout, the combustor exit temperature (CET) is about 135 °F cooler when water injection is used. At the point where water injection is discontinued, about 4 n mi from takeoff roll, the CET returns to temperatures that are almost the same as the baseline PW4062 engine. It is a few degrees cooler at this point due to the turbine rematch that was required to correct the compressor surge margin issue.

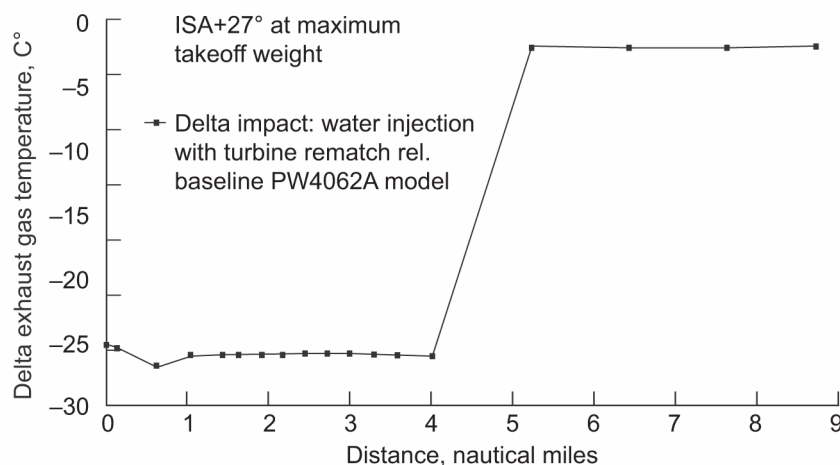

Figure 51.—EGT decreases 25 °F with water injection.

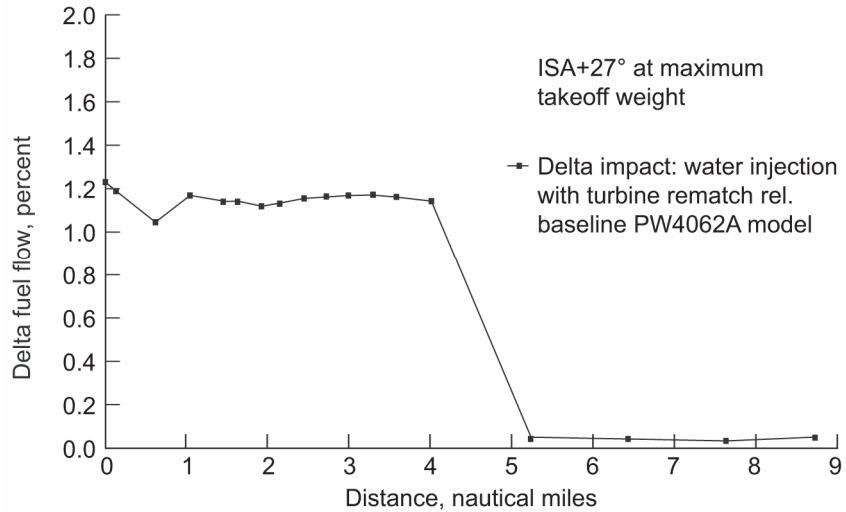

Figure 52.—SFC increases 1.2 percent during takeoff when water injection is used.

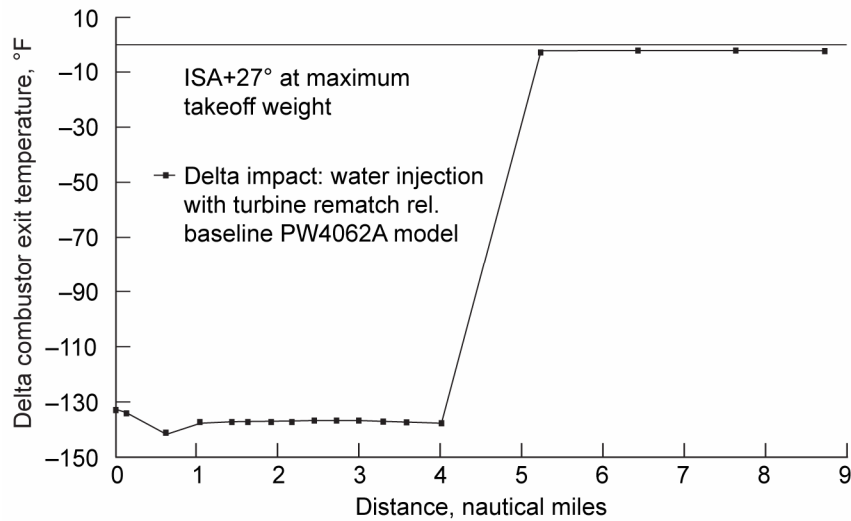

Figure 53.—CET decreases 135 °F when water injection is used.

One of the benefits of decreasing combustor exit and turbine inlet temperatures is that it can improve the life of the engine hot section. When looking at the normal T41 temperature profile from takeoff to climb in figure 54, one can see from the top solid line that the turbine is exposed to its peak temperature during the 90 sec takeoff and climbout phase of flight, which takes the airplane to about 2 n mi from takeoff roll.

The bottom dashed line shows the T41 profile of an engine with 1:1 water-to-fuel injection rate. Once the aircraft reaches 3000 ft altitude (about 4 n mi) the water-injection system is turned off and the T41 temperature returns to normal. Thus, using water injection during the takeoff roll and climbout will reduce the most life-demanding peak temperature level to about that of normal climb condition.

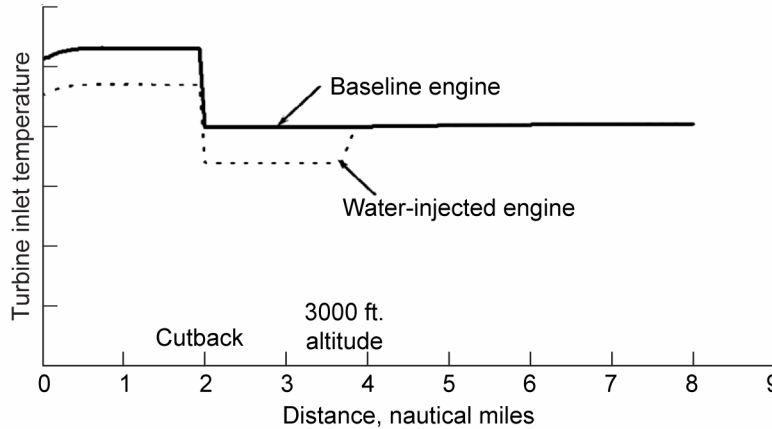

Figure 54.—Using water injection cuts peak blade temperature right where it is needed most—during takeoff.

3.4.5 Engine Performance Impact for Water Misting.—Due to the more-limited industrial engine experience with misting water into the LPC, there was higher uncertainty of how water misting would affect the aeroengine’s performance.

Two of the most important parameters needing to be addressed were to validate the degree of T4 reduction estimated from the earlier modeled results (ref. 1) and to address the issue of possible compressor surge margin deterioration.

A ratio of 0.022:1 water-to-core airflow ratio was modeled by NASA in the earlier study for another engine model, which predicted a 436 °R reduction in T4 and 47 percent NO_x reduction. For this study the Pratt & Whitney PW4062 engine model predicted a 410 °R reduction in T4 with similar water flows. Figure 55 shows the T41 reduction as a function of water misting rate and also shows the effect on rpm for the first engine spool (N1), the second engine spool (N2), and the compressor exit temperatures (T3). All of the variables decline when the water-injection rate is increased.

As some engines reach maximum temperature limits from T3 and T41 reductions result in higher turbine life, these dramatic reduction levels are very desirable to achieve. Reductions in N1 and N2 with water misting would also allow for increased thrust from those engines that are “red line” speed limited. Thus, this chart shows all positive results.

When water is misted into the inlet of a compressor, the total mass flow through it increases. Changing the mass flow, without changing other operating conditions, can lead to operating difficulties.

At any given rotational speed, an engine compressor is designed to produce a certain airflow rate, which will then achieve a certain pressure rise in the engine. The engine controller senses, among other things, pressure rise from the compressor and uses this to regulate the amount of fuel flowing into the combustor based on the assumption that this pressure rise is related to a particular flow rate.

If a certain compressor output pressure is being maintained, and water is added to the airstream, the total mass flow increases. As the engine was not designed to use this added mass flow, the air and water (in effect) starts to back up inside the compressor and will reach a point where the compressor will surge, meaning the airflow will start to reverse direction.

The difference between the surge point and the operating point is called the “surge margin.” Adding water to the inlet of the LPC decreases surge margin. If the water is completely evaporated prior to it entering the compressor, figure 56 shows the modeled surge margin deterioration for LPC and HPC. When adding water to the air in a 0.022:1.000 ratio, the surge margin on the LPC will deteriorate 9 percent. Although a stationary turbine operating under stable conditions may be able to tolerate this kind of deterioration, it was considered too high for aircraft operation. The HPC surge margin will deteriorate 3 percent.

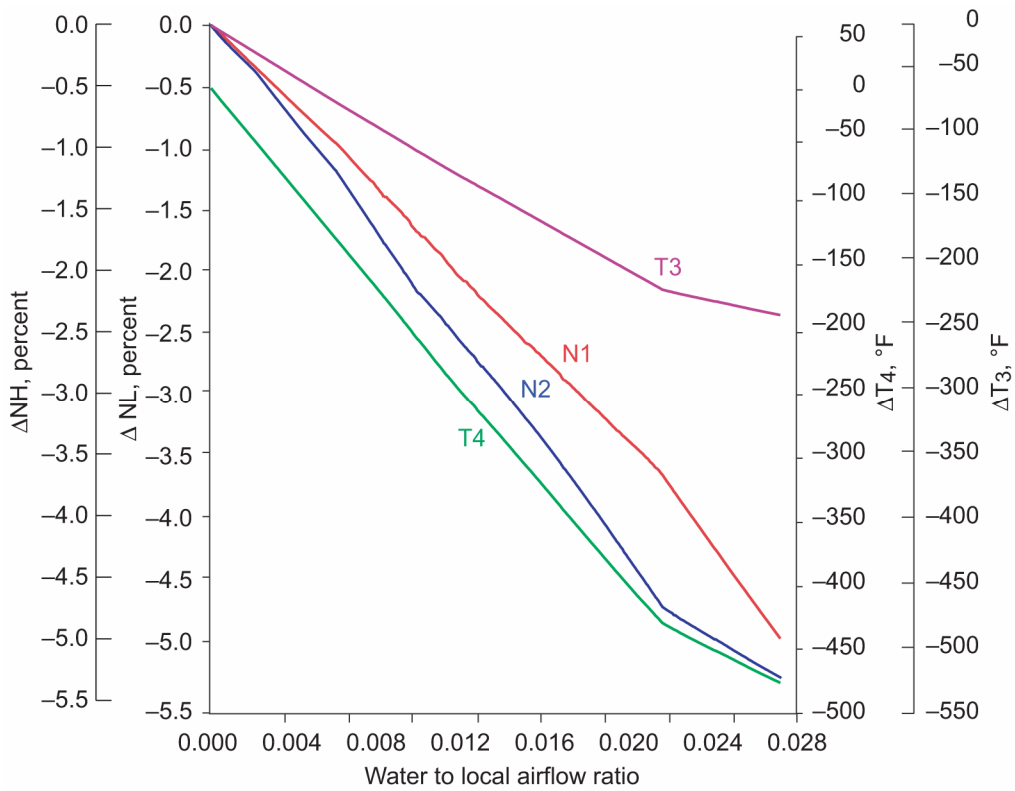

Figure 55.—Water misting results in a 410 °F reduction in T41.

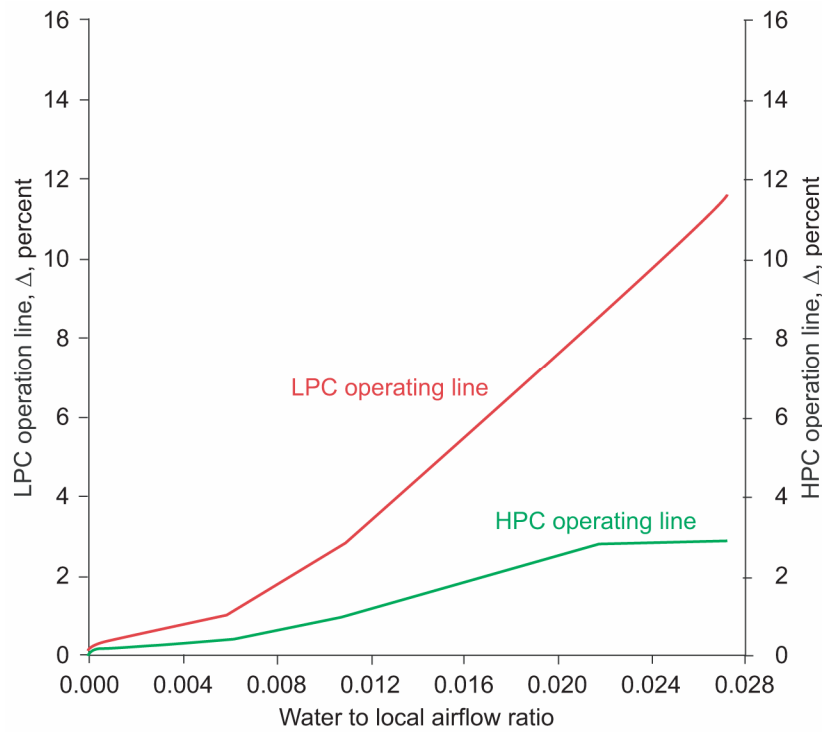

Figure 56.—Water misting results in an unacceptable 9 percent loss in LPC surge margin.

	Combustor Water Injection	Water Misting
Water use (for 50% NO _x reduction)	√ Uses half the water	
NO _x reduction	√ Capability to 90 percent	
T3 affect		√ Reduced
T4 reduction		√ Larger reduction
SFC impact		√ Improved
Surge issues	√ Much less impact	
Noise		√ Less noise
Risk	√ Less risk	

Figure 57.—Combustor water injection was chosen as the system to focus on.

Due to the high surge margin deterioration level modeled for the LPC, the following combustor water-injection system was deemed a more likely candidate. Figure 57 shows the pros and cons between the two systems and why the water-injection system was chosen to be focused on.

3.4.6 Turbine Life.—The turbine life impact of using water injection is probably the most critical finding of this study as it affects airplane operating cost, which will most likely be the determining factor in the market implementation success of water-injection technology. For most airplane operators, a reduction of NO_x emissions will be a secondary concern.

The exact methodology of determining turbine life is proprietary to the engine companies. In addition, turbine life impact is expected to vary between engine companies, engine models, operating manner, and ambient weather conditions. However, the calculated end results of using water injection will be presented from two manufacturers. In addition, turbine life trends will be discussed in an attempt to understand the basis of these life estimates.

Depending on the amount of water injected, the airplane operating conditions encountered, and the susceptibility of the turbine blade metal to temperature, the most severe life-limiting part of the blade's life (takeoff) can be controlled.

3.4.6.1 Turbine Life Design and Operating Issues: The hot section part of an engine consists of the combustor and high-pressure turbine assembly. Due to the high temperatures, pressures, and rotational speeds of the components in these areas, the hot section is typically exposed to a harsher environment than the rest of the engine. These components can have a significantly lower service life than the rest of the engine (ref. 9) as illustrated in figure 58.

It is difficult to determine a fatigue limit or a stress at high temperatures below that no failures will occur (ref. 10), although table IX illustrates the design practices, and service life experience, of a relatively modern (i.e., 1980s vintage) turbine engine that is still in use today (ref. 11). The highest T41 temperature occurs during the 90 sec takeoff period. On a standard day, about 36 percent of the turbine blade's life is consumed during this short period of time. In total, the operating time at takeoff amounts to about 300 hr (<2 percent) of the turbine's 18 000-hr design life.

TABLE IX.—36 PERCENT OF A HP TURBINE IS CONSUMED DURING THE SHORT TAKEOFF PERIOD

Condition	Life used, percent	Time, hr
Takeoff	36	300
Max. climb	49	3 300
Max. cruise	15	7 200
Balance	< 0.1	7 200
Total	100	18 000

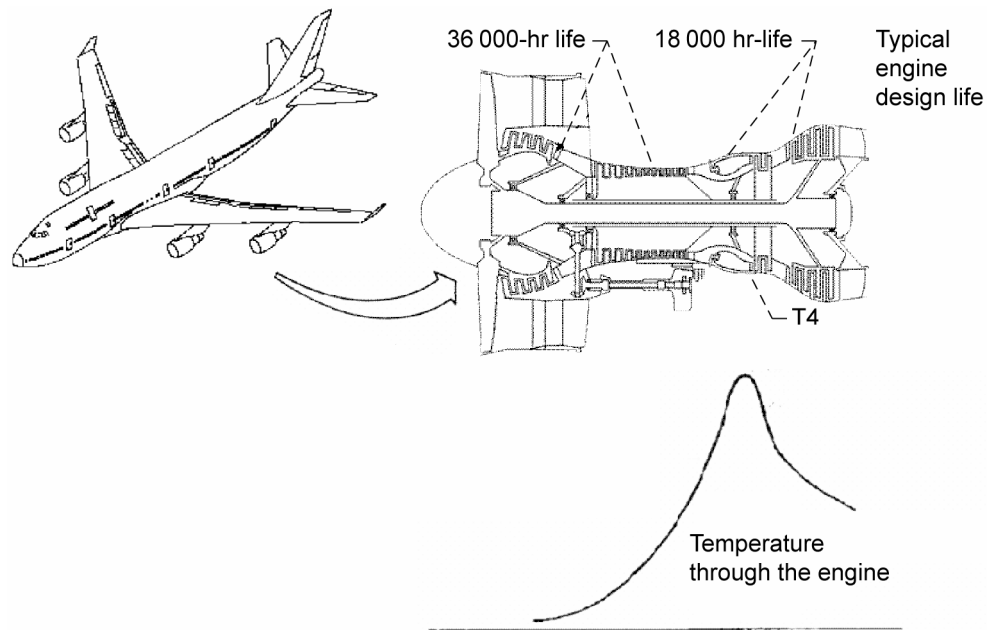

Figure 58.—Hot section design life is often shorter than the rest of the engine due to the challenging high temperature environment.

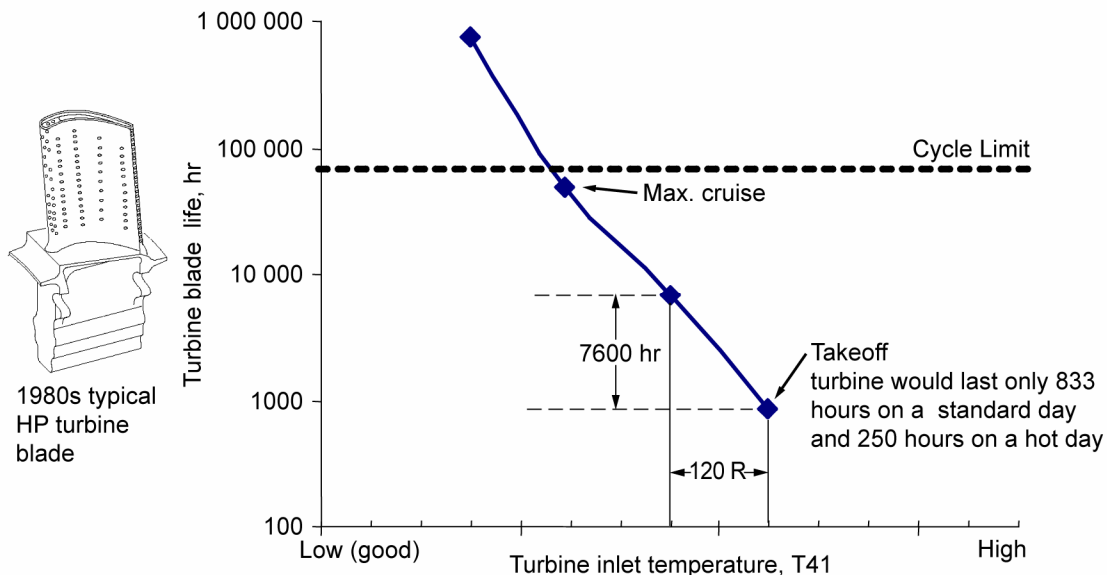

Figure 59.—Reducing operating temperature can significantly increase aeroengine turbine blade life.

By reducing T41 temperatures during takeoff, turbine life will typically increase. Section 3.4.5 showed that using water injection during takeoff would reduce the peak turbine inlet temperature approximately 120 °R for the combustor water-injection case. To understand the significance of this temperature reduction, the following discussion is offered to show examples of how peak temperatures adversely affect turbine blade life.

Turbine blade life decreases rapidly with increases in temperature. On a 1980s vintage example engine, an engine operator would only achieve an 833-hr turbine blade life if the engine was operated continuously at takeoff conditions (ref. 11). Using the turbine blade life data for each operating point provided in table IX, and corresponding T41 data that were calculated from Boeing engine performance models under standard day conditions, figure 59 was created for illustration purposes only. It shows

that there is a logarithmic relationship between T41 temperatures and turbine blade life. From this illustration, it was estimated that turbine blade life could increase approximately 7500 additional hours from the 833 hr at takeoff, if water injection was used to reduce the operating temperature 120 °R—a 10-fold improvement in turbine life at continuous takeoff conditions.

Based on the above sample engine (used for illustration purposes only), the life extension during takeoff would reallocate the percent of turbine life used at each operating point. For example, simple calculation results are shown in figure 60 that suggest the turbine design life might increase from 18 000 to 26 233 hr—an estimated 46 percent increase in design life.

The effect of using water injection and its corresponding reduction in T41 is now compared to operating the engine in different ambient conditions without water injection. Figure 61 shows how T41 varies with changes in ambient temperature conditions for a similar aero gas turbine engine. For constant thrust conditions, as ambient temperature increases, there is a much larger increase in T41. Similarly, T41 decreases linearly when the ambient temperature drops below the 60 °F reference condition.

For the case of using water injection on a 60 °F day and the resulting 120 °F reduction in T41—this is equivalent to operating the engine without water injection on a day that is 28 °F cooler than 60 °F (i.e., 32 °F).

	Base engine		Water injected engine*	
	Life used (%)	Total time	Life used (%)	Total time
Takeoff	36	300	3	437
Max. climb	49	3,300	71	4,809
Max. cruise	15	7,200	22	10,493
Balance	Nil	7,200	2	10,493
Total	100	18,000	100	26,233

*ROM estimate

Figure 60.—Using water injection during takeoff could reallocate the percent of turbine life used at each operating point.

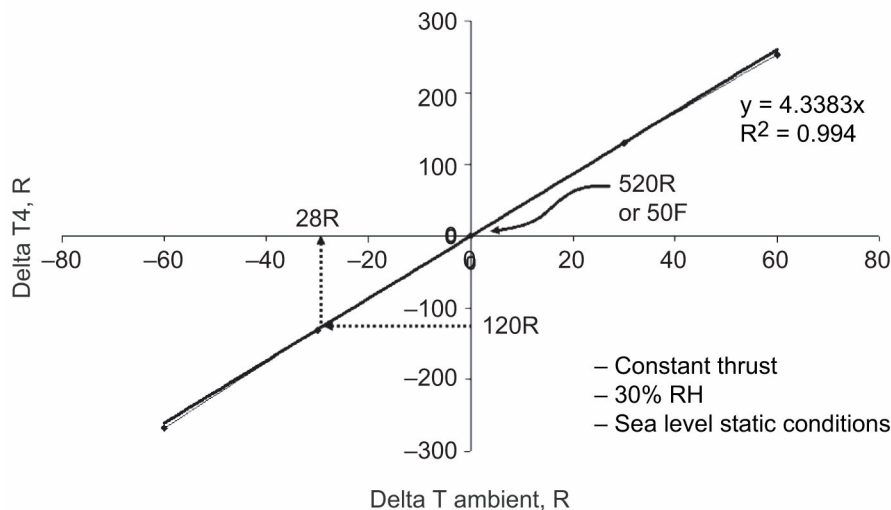

Figure 61.—The 120 °F reduction in T4 achieved when using water injection on a 60 °F day, is equivalent to reducing the ambient temperature 28 °F.

3.4.6.2 *Turbine Life Trends*: The potential life benefit analysis presented here focuses specifically on turbine blade life assuming that turbine life is primarily limited by blade life. The dominant mechanisms of failure in the turbine are identified as low-cycle fatigue, creep, and oxidation. Owing to the complexity of the interactions between these failure mechanisms and the lack of detailed knowledge about the loads and temperatures involved in the study engine, a high-fidelity life model is not feasible for this study. Consequently, a fatigue life analysis using an empirical model is presented along with a brief overview of the effects of creep and oxidation as found in the literature.

Using the Universal Slopes method (ref. 12), a preliminary quantitative analysis has been performed for possible fatigue life benefits from water injection. The Universal Slopes Method is a modified version of the Coffin-Manson and Basquin equations with experimentally obtained coefficients and is given by

$$\Delta\varepsilon_{\text{total}} = 3.5 \frac{\sigma_{\text{ult}}}{E} N_f^{-0.12} + \varepsilon_f^{0.6} N_f^{-0.6} \quad (1)$$

where, $\varepsilon_f = \ln(1 + \% \text{elongation})$, or $\varepsilon_f = \ln\left(\frac{1}{1 - RA}\right)$

Nickel-based superalloys, Inconel 625, Inconel 706, and Rene 80 were used for this analysis (refs. 13 to 15). The total strain was selected such that the respective stress level is limited from 40 to 80 percent of the ultimate tensile strength at a given temperature level. This corresponds to applying a design factor of safety of 2.5 to 1.25, respectively. The life cycles to failure were acquired from equation (1), varying strain levels and material properties with temperature. Life ratios were obtained by dividing the cycles to failure at each temperature and strain level by the cycles to failure at the maximum temperature and strain level. Figure 62 shows the results obtained for Inconel 625, Inconel 706, and Rene 80.

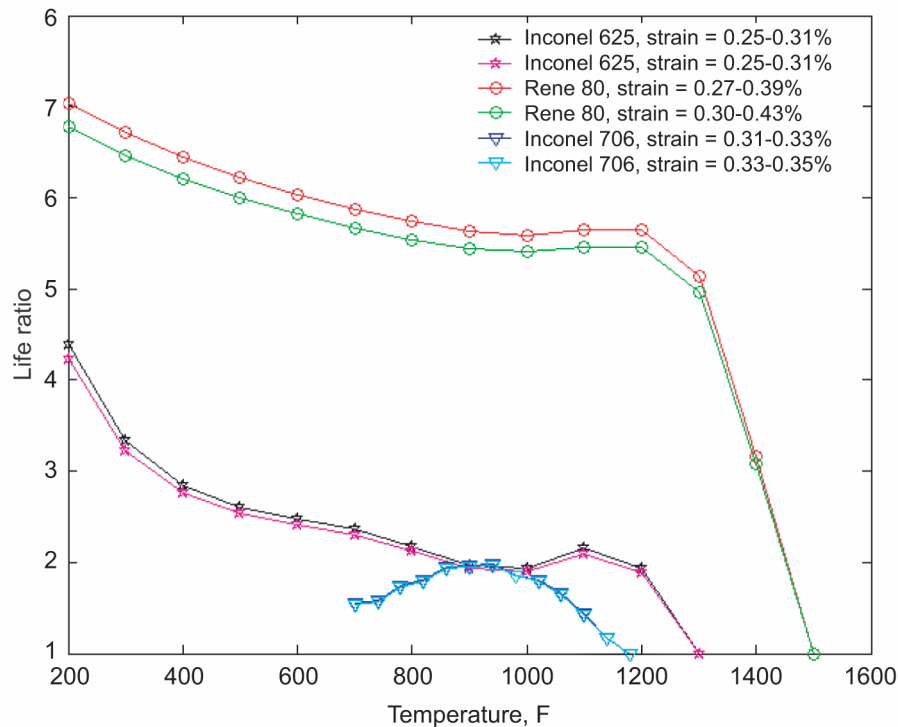

Figure 62.—Inconel 706 and Rene 80 total life estimate.

The overall trend noticed in figure 62 is that life benefits improve with decreasing temperature. In the case of Inconel 706, the life ratio curve appears different from those of Inconel 625 and Rene 80. The differences in the life estimate behaviors of Inconel 706, Inconel 625, and Rene 80 primarily arise from variations in material properties and strain levels used. Additionally, the range of temperatures used for Inconel 706 is narrower than those used for the other materials, which puts limitations on the comparisons possible. It is seen that for a 120 °F reduction in the turbine inlet gas and blade temperatures, life improves by a factor of approximately 2 for Inconel 625, 1.65 for Inconel 706, and about 3.5 for Rene 80. As noted from this comparison, an accurate estimate for life benefits can only be obtained with a detailed analysis using the material properties, metal temperatures, and load levels involved in the specified engine type.

There will also be differences in the life benefits possible depending on ambient operating conditions. The magnitude of turbine life improvement will depend on the nominal operating metal temperature. As seen from figure 62, the slope of the fatigue life ratio curve changes depending on the temperature range concerned and thus life benefits can be significantly higher at temperatures where the slope is steep as compared to where the life curve flattens out.

In addition to the limitations arising from the lack of detailed data, there are also some notable shortcomings in the application of the Universal Slopes Method. The coefficients used in equation (1) are obtained through isothermal, room temperature fatigue tests done on a wide range of materials. As shown in the Manson report (ref. 12), these average coefficients provide fairly reliable life estimates for the 29 materials tested with 99.5 percent of the experimental data falling within a factor of 20 of the predicted life. However, life estimates obtained under thermomechanical fatigue (TMF) can vary significantly from those obtained from isothermal low-cycle fatigue. Under in-service conditions, turbine blades are exposed to widely varying thermomechanical loads, and simplified isothermal models do not capture the complexity of the situation. The deviation of isothermal results from TMF results depends largely on the material properties and the nature of the TMF cycle. The primary reason for the use of the Universal Slopes Method in this analysis was the ease involved in its use and availability of the necessary material data. Despite its shortcomings, this method is a good tool for a preliminary design level analysis where the overall trends in life behavior are sought.

In order to provide an estimate for creep and oxidation life benefits from water injection, we present some relevant results available in the literature. Based on common industry practice (ref. 16), approximations for changes in the first stage turbine blade life resulting from changes in gas and metal temperatures as well as centrifugal stresses are shown in table X.

TABLE X.—TURBINE BLADE LIFE ESTIMATE
VARIATION WITH TEMPERATURE AND STRESS

Variation	First blade creep-fatigue life	First blade oxidation life
Local gas temperature ±18 °F (mean 3140 °F)	±15 percent	±14 percent
Metal temperature ±5 °F (mean 1340 °F)	±8 percent	±8 percent
Centrifugal stresses ±1 percent	±6 percent	-----

It can be noted from table X that blade life estimates are sensitive to the gas and metal temperature as well as stress levels used in the analysis. The combined effects of thermomechanical fatigue, creep, and oxidation are usually studied experimentally and then modeled based on the data obtained. However, from the first-order analysis presented here, it is seen that there may be significant hot section life benefits resulting from water injection. In order to quantify these results with more confidence, detailed experimental studies replicating the operating conditions under water injection on appropriate turbine blade materials are necessary.

	Pratt & Whitney	Rolls Royce
ΔT (°F)	-120	-120
Percent life improvement estimate ^a	29 percent ^b	0 to 20 percent ^c

Notes:

^a3 k n mi mission length, 1:1 water-to-fuel injection ratio

^bTurbine service life (1990s to 2000 technology PS4062 engine)

^cVaries dependent upon engine operating conditions

Figure 63.—There is agreement within the industry that water injection will reduce T41 and improve turbine life but disagreement by how much.

3.4.6.3 Estimates of Turbine Life From Engine Companies: The previous discussion estimated design life impacts on the turbine when using water injection. The following discussion includes estimates from engine companies who provided data of expected turbine in-service life impacts. This includes experience-based models, which may explain the difference in turbine life estimates between design and in-service.

The Pratt & Whitney Engine Corporation supplied turbine blade life estimates to Boeing under contract from NASA Glenn. A series of proprietary temperature adders were used in conjunction with the original performance parameters to determine the basis for the airfoil durability assessment.

These adders include performance-miss factors, engine-to-engine variation, speed power setting, transient overshoot, and deterioration. Other design elements, such as pattern factor, profile factors, performance-to-gas temperature ratios, relative-to-absolute temperature ratios, coolant-to-compressor discharge temperature ratios, overall file and cooling effectiveness with and without thermal barrier coatings were included in the durability analysis.

The analysis showed a 120 °F T41 gas temperature decrease, which was predicted from the 1:1 water-to-fuel injection ratio. This resulted in a 78 °F decrease in turbine blade metal temperature. Using the Pratt & Whitney life assessment tools for thermal barrier coating spallation, or metallic and alloy oxidation, an expected life improvement of 29 percent was achieved.

Although Pratt & Whitney was the only engine company under NASA contract to supply turbine life estimates for water injection, other companies and organizations provided estimate ranges. The engine company-supplied data is shown in figure 63.

Rolls-Royce estimated the turbine life could potentially increase up to 20 percent for a newly designed engine that is operated in a hot climate. However, for cold-climate operation using thrust derate, there could be no savings at all.

As mentioned above, the turbine life will vary depending on the operating conditions of the airplane. In addition to this variability, the Pratt & Whitney analysis was performed assuming the engine was operated at full-power conditions under average-day conditions. Many flights are operated under some level of thrust derate. As thrust derate will improve the life of the turbine, water injection will have less of a life benefit during these episodes.

Combustor wall radiative heat loading should be reduced, which will reduce wall temperatures and could therefore also increase combustor life. There could be other unforeseen impacts to the engine, such as turbine blade thermal barrier coating impacts, which needs to be resolved by testing and eventually by performing engine endurance tests.

3.4.7 Emissions.—Some aircraft emission byproducts (CO₂) are a direct result of the efficient combustion of fossil fuels and are a direct function of airplane fuel efficiency. Other pollutant emissions are more related to the way fossil fuels are combusted. These regulated emissions are oxides of nitrogen—collectively called NO_x, hydrocarbons (HC), carbon monoxide (CO) and smoke. Other atmospheric emissions or byproducts of aircraft operation are contrails and ozone generation at cruise conditions (fig. 64).

As water injection primarily affects engine combustion emissions, we focus on how those resultants are impacted.

NO_x generation is primarily a function of temperature; higher combustor flame temperatures lead to higher NO_x emissions (ref. 17) and are illustrated in figure 65. Many years ago, water injection was shown to be highly effective in reducing smoke as well as NO_x emissions (ref. 18). It has since been used in many industrial aeroderivative gas turbine engines to reduce NO_x emissions. In these engines, water injection's impact on engine emissions, maintenance, and costs are well documented (ref. 19).

The effect of using water injection is to reduce combustor temperature just enough to shift the NO_x-generating mechanism into a lower temperature regime. Figure 66 shows that as the water-to-fuel ratio is increased, the turbine inlet temperature decreases, which is typically only a few degrees cooler than the combustor exit temperature. In this case, a 1:1 water-to-fuel ratio was calculated by NASA's NEPP to reduce T4 some 125 °F, which is very close to the 120 °F value obtained by the Pratt & Whitney model (ref. 7).

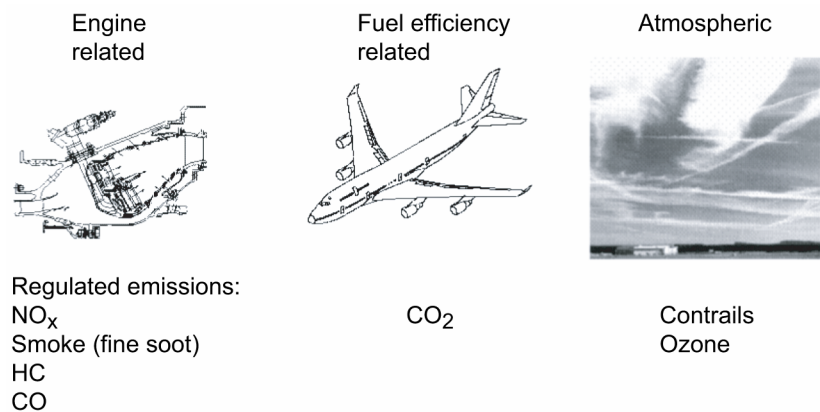

Figure 64.—NO_x, smoke, HC, and CO are the regulated engine emissions.

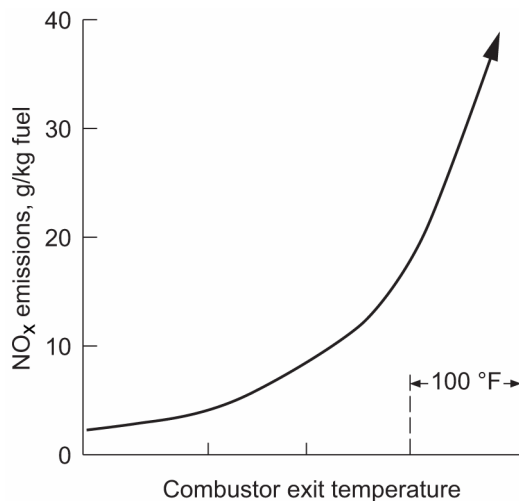

Figure 65.—NO_x emissions increase rapidly with combustor temperature.

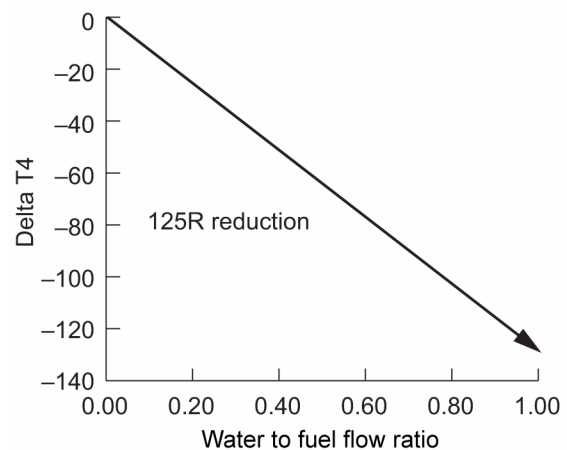

Figure 66.—Adding water to the fuel reduces combustor temperature.

As was seen in figure 65, this 120 to 125 °F reduction in temperature can greatly reduce NO_x emissions when the combustor flame temperatures are sufficiently high as to be on the steep part of the emissions slope curve. Figure 67 compares the NO_x emissions index (EINO_x) reduction capability of water injection by plotting test data from a current technology Boeing 777 engine, two industrial engines (ref. 25), a very large 35-mW industrial engine (ref. 20), and laboratory tests of an experimental TVC sector rig (ref. 21) and current technology aeroengine combustor sector (ref. 22).

Although there is some scatter in the degree of NO_x reduction, figure 67 shows surprising similarities between engines that are old or new, industrial or aeroengine, large or small, experimental or production combustors, as well as full-scale or laboratory sector rigs. Thus, it appears as though water injection will reduce NO_x emissions on the order of 80 percent when a 1:1 water-to-fuel ratio is used during takeoff.

Using a NASA NEPP model and Boeing airplane performance and emission decks for validation, figure 68 shows the present airplane NO_x emissions profile and the water-injected NO_x profile for the large-sized study aircraft. At 3000-ft altitude (4 mi from takeoff), the 400 gal of water are exhausted. At this point, the amount of NO_x saved will have been 56 lb, achieving an 80 percent reduction in takeoff and climbout NO_x. This includes the NO_x reduction due to the overall fuel savings of using water injection.

After reaching a 3000-ft altitude, the NO_x emissions resume their same trajectory. However, the amount of NO_x reduction, especially within the airport vicinity, is very impressive.

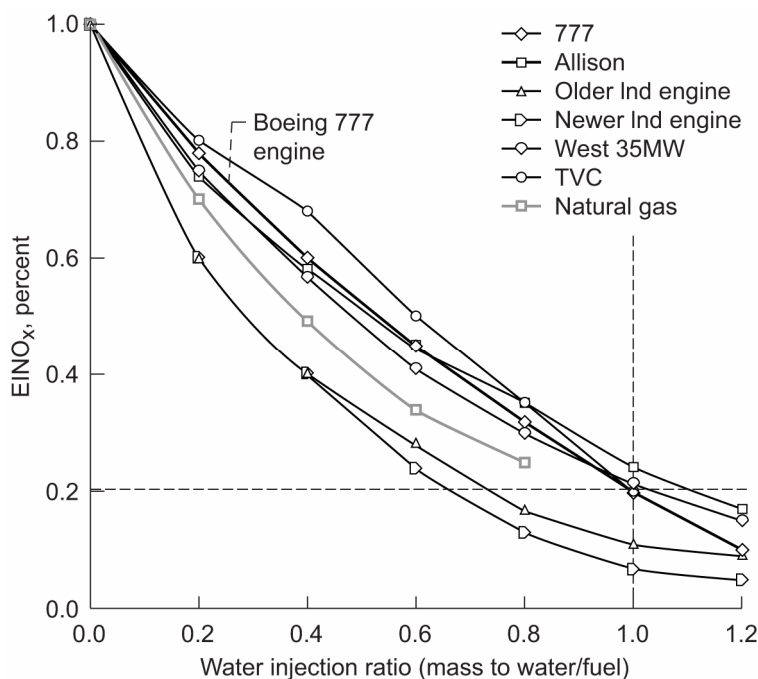

Figure 67.—Tests have shown 1:1 water-to-fuel ratio will reduce NO_x emissions 80 percent, which is in the range of other tests.

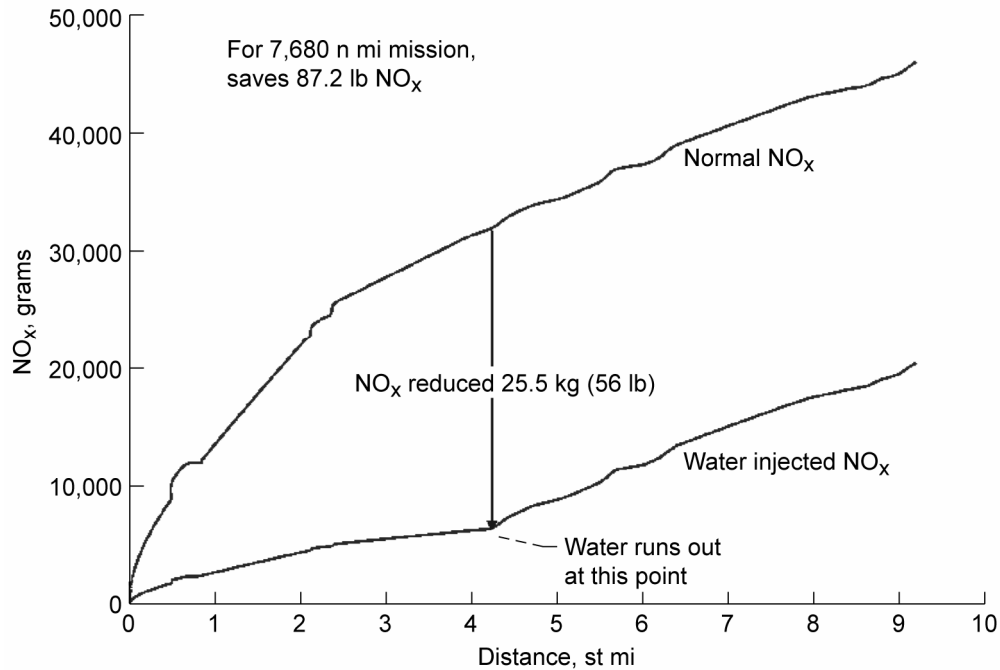

Figure 68.—Reducing NO_x 80 percent during takeoff will save 56 lb (25.5 kg) of emissions for a 747-400 aircraft.

Even though water injection is quite successful in reducing NO_x emissions during takeoff, low-emission combustors are still needed for the cruise and climb portion of the flight. Although the rate of NO_x emissions is high during takeoff and initial climbout, most NO_x is generated during the long cruise and climb periods where water injection is impractical to use due to the large quantity of water that would be required.

Smoke emissions are also anticipated to be reduced by water injection. Previous data (fig. 69) has shown that water-injection rates of up to 1:1 water-to-fuel ratios may be beneficial in reducing smoke emissions (ref. 23).

Figure 70 shows the relationship of water injection to smoke emissions reduction for a current technology aeroengine for a Boeing 777 aircraft. As the inlet pressure to the combustor increases with increasing power setting, the SAE smoke number increases for the baseline engine, indicating that smoke emissions are increasing. When water injection is used on the same engine in a 1:1 water-to-fuel ratio, the smoke number appears to decrease dramatically. In most cases, the smoke number was too small to measure when using water injection. Similar results were obtained when increasing a water-to-fuel injection ratio of 1.2:1.

It should be noted that the range of measurement accuracy is ± 3 , as denoted by the dashed line for the baseline case. When accounting for the measurement accuracy of the water-injected points, these test results may not provide any statistically meaningful results.

It is unclear how water injection may affect small particulate emissions (e.g., PM_{2.5}). As this is an area of increasing interest, since these types of emissions may have health implications, plans are underway to evaluate the effect of water injection on particulate emissions in a laboratory combustor (ref. 24).

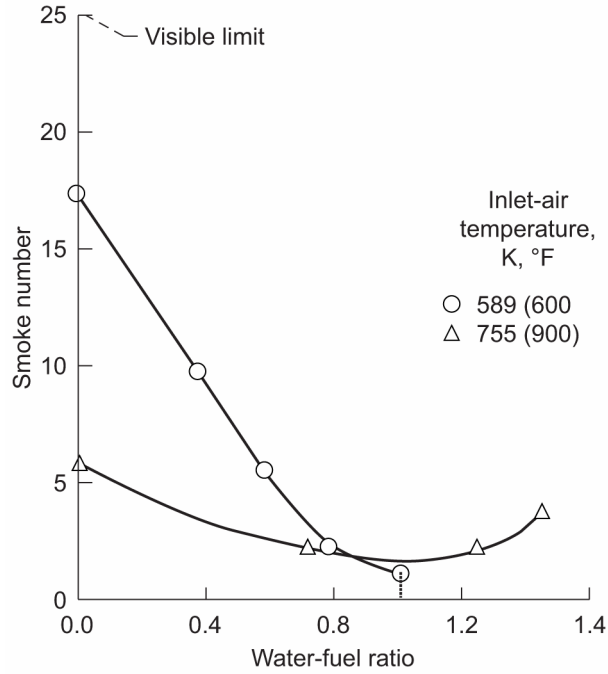

Figure 69.—Previous tests by others have also shown that water injection reduces smoke.

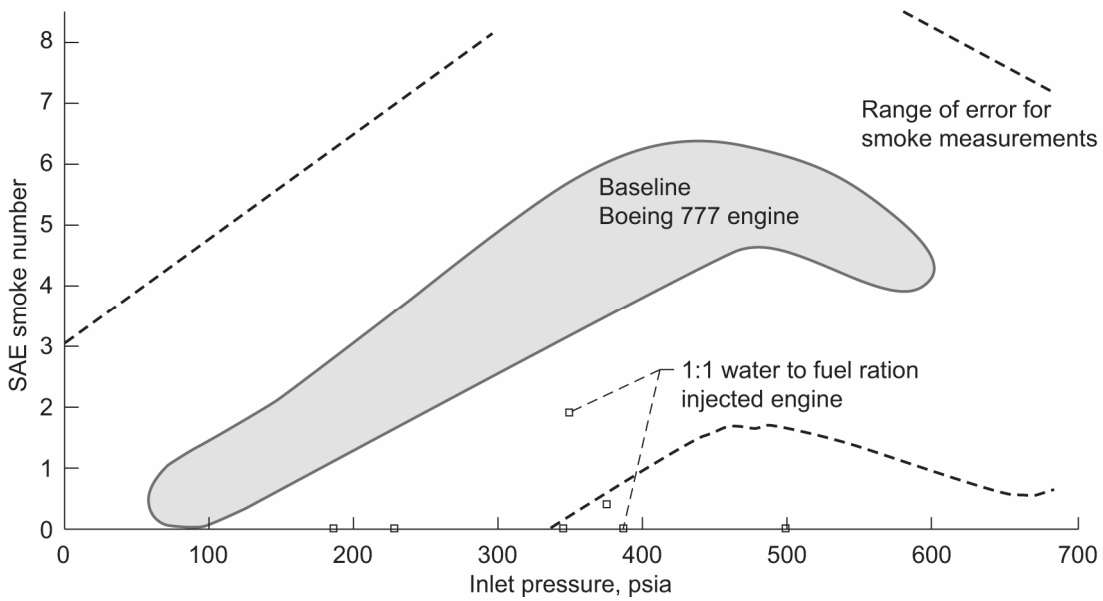

Figure 70.—Tests on modern aeroengines have shown that water injection reduces smoke emissions.

One of the possible negative aspects of water injection is its tendency to generate more hydrocarbons (HC) and carbon monoxide (CO) emissions. CO emissions data is available from ground-based industrial systems that suggest this may be a manageable issue for engines with higher overall pressure ratios (OPRs) (ref. 25). Increases in HC emissions are anticipated to be minor and due to the very low regulatory level that most aircraft engines already operate at, any increases in HC emissions should be well within regulatory requirements.

As new, low NO_x combustors are usually only able to offset the additional NO_x that is generated by newer, higher pressure ratio cycle engines. Water injection would be able to provide reduction of real emissions during takeoff and climbout conditions. Smoke emissions may decrease by an order of magnitude, while HC and CO emissions are anticipated to increase only slightly.

3.4.8 Noise.—A community noise analysis was conducted by Pratt & Whitney for the 747–400 study aircraft at 910 K takeoff gross weight (TOGW) (666 K lb landing weight) with water-injected PW4062 engines. These engines incorporated the turbine rematch to correct for the compressor surge issue. A very small noise improvement was predicted for sideline and cutback noise. There was no difference for approach noise.

The in-flight engine performance was studied to compare the Fan Corrected Speed (NLR2A) and mass-averaged jet velocity (MAVEL) at the required in-flight net corrected thrust for the three flight conditions. These two parameters are used to correlate fan and jet noise.

Approach noise: The fan speed and jet velocities were unchanged by the turbine rematch. As water injection is not used at approach, no change to noise is anticipated.

Sideline noise: Water injection reduced the required fan speed and expected jet velocity at the required takeoff thrust. This slightly reduced the sideline noise less than 0.3 EPNdB for an aircraft with a TOGW of 910 K lb.

Figure 71 shows that the MAVEL is reduced about 3 ft/s at a constant thrust when using water injection. This reduction level is relatively constant across the thrust range levels.

When using water injection, the corrected fan speed is also reduced about 20 rpm, as shown in figure 72. This also helps to reduce noise at sideline and takeoff conditions.

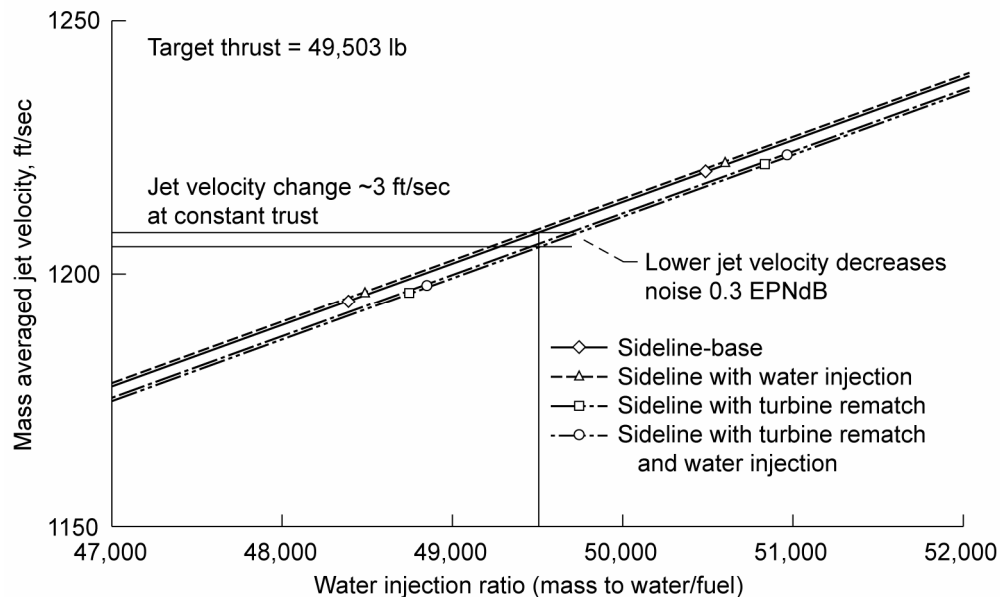

Figure 71.—Water injection was estimated to reduce sideline takeoff noise by 0.3 EPNdB partly due to reduced jet velocity.

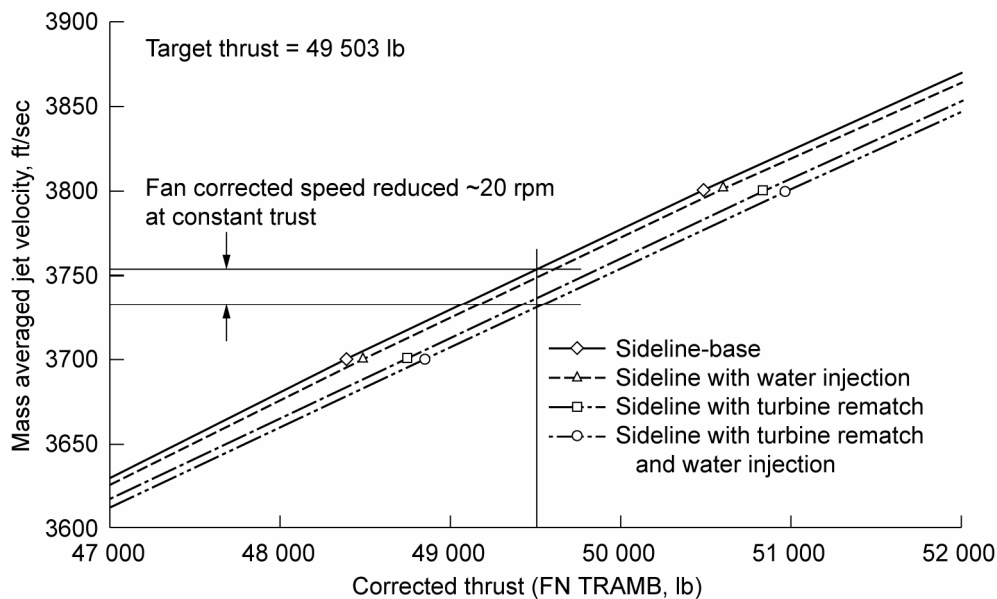

Figure 72.—Water injection also reduces noise by decreasing the corrected fan speed (N_1).

Cutback Noise: The same effect as was seen in the sideline case applies to noise at cutback. Namely, reduced fan speed and mass average jet velocity contribute to a slightly quieter noise level.

The degree of noise reduction in all of the three cases is minimal, and thus no environmental credit will be taken in this area. However, it does show that noise will not negatively impact the airplane.

3.4.9 Airport.—A meeting was held with environmental and logistical support personnel at Los Angeles International Airport (LAX) to discuss the implementation challenges and desirability of water injection. Although there will be implementation challenges for aircraft (they already use water injection for their ground power turbine) the airport authority would support the technology if they could take credit for the emission reductions achieved.

There will be issues with supplying conditioned water to the aircraft at the gate, but the airport will ultimately be the end beneficiary of water injection since it will improve the local air quality. Accordingly, the issues and benefits to the airport need to be addressed.

One of the challenges that LAX has to address is how to get the conditioned water to the aircraft. As this airport is very busy, they could not withstand any increase in ramp traffic that would occur with additional water service trucks. It was thought that a dedicated conditioned water distribution system would be needed so that each airplane could be serviced at the gate.

Although the estimated water conditioning costs of \$0.01 to \$0.02 per gal are quite affordable (refs. 1 and 8), the dedicated water distribution system is anticipated to be very costly to the airport. However, if the airport could receive economic credit for reducing its NO_x emissions, it may prove to be a worthwhile investment.

For its investment in such a system, LAX (and presumably other large airports) want some means to account for the degree of NO_x emissions reduction from water injection. This accounting process needs to be relatively easy for the airport and operators to use. It was thought that each airline might submit an annual record of the number of times each type of aircraft was refilled with water. The International Civil Aviation Organization (ICAO) emissions data sheets for each engine type could then be used to calculate the amount of NO_x reduction achieved at the airport.

Another issue that surfaced was how to drain the aircraft's water tanks. A small amount of water drainage could be tolerated. However, if the tanks needed to be completely drained, then the 400 gal of

water could not be drained onto the ground. For these rare situations, it might then be acceptable to have a water service truck drain the aircraft's water tanks.

LAX airport is becoming increasingly aware of the attention being paid to particulate emissions. Several studies have been conducted, or are planned, to address fine particulate emissions. If water injection reduces these emissions, it would be of value to the airport.

Lastly, the airport sees this technology for airplanes as not only a means for continued existence, but an avenue to grow its flight operations.

3.4.10 Airplane Performance Impact.—The water-injection system will adversely impact airplane performance in three ways: required 4 gal more fuel during takeoff, increased fuel burn by 20 gal during the rest of the mission, and for a retrofit or current production airplane, reduced the payload and range of the aircraft. This is due to the SFC penalty when using water injection and the weight of the system.

For the combustor water-injection system, the engine suffers a 1.2 percent increase in SFC during climbout due to the thermal efficiency loss of cooling the combustion products. Using water injection to 3000-ft altitude results in a 26 lb (4 gal) increase in fuel consumption as shown in figure 73.

There is also a cruise fuel penalty from having to carry the added weight of the water-injection system. For the 747-400 aircraft equipped with either of the water-injection schemes on a 3000 n mi mission, an additional 20 gal (137 lb) of fuel would be required to carry the weight of the empty system.

For the entire 3000 n mi mission, 24 gal of more fuel would be required for the combustor water-injection system as shown in figure 74.

For a newly designed engine and airframe, the airplane design can be cycled to account for the added weight of the water-injection system, so the payload and range penalties would be removed as compared to the baseline airplane. The operating empty weight (OEW) would increase though, which is undesirable. For a retrofit or current production airplane, the added weight of the water-injection system and the water itself would decrease the payload and range.

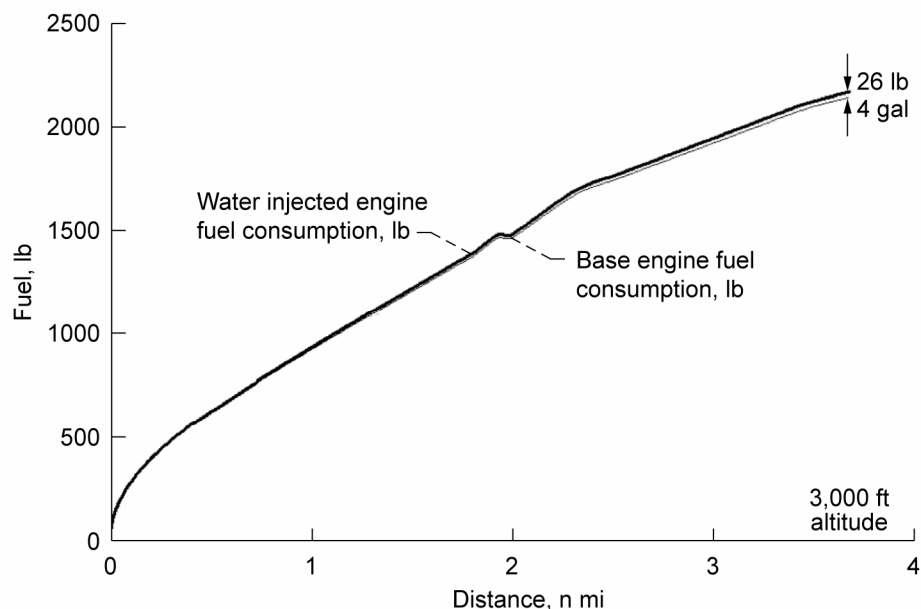

Figure 73.—The 1.2 percent SFC penalty for using water injection to 3000 ft results in 4 gal more fuel use during takeoff.

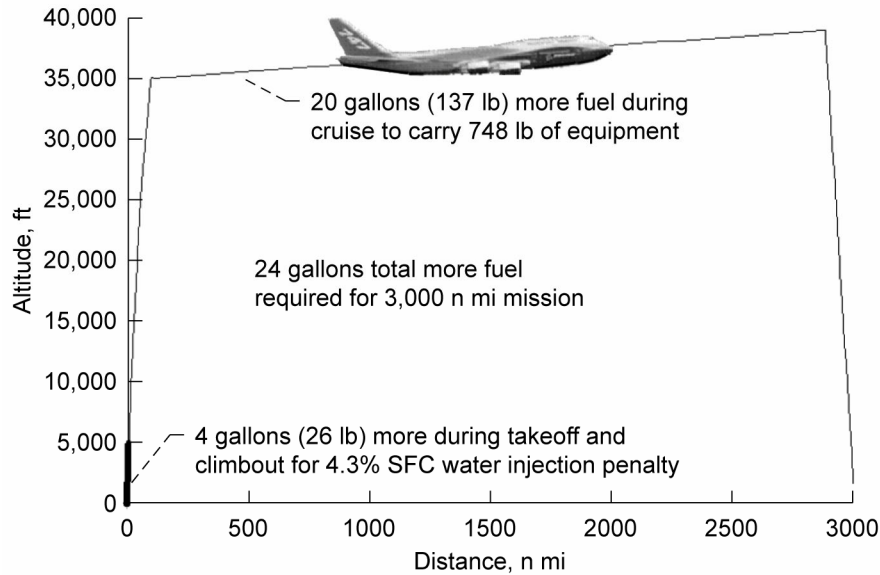

Figure 74.—Added system weight and takeoff SFC penalty together result in an additional 24 gal of fuel used on a 3000 n mi mission.

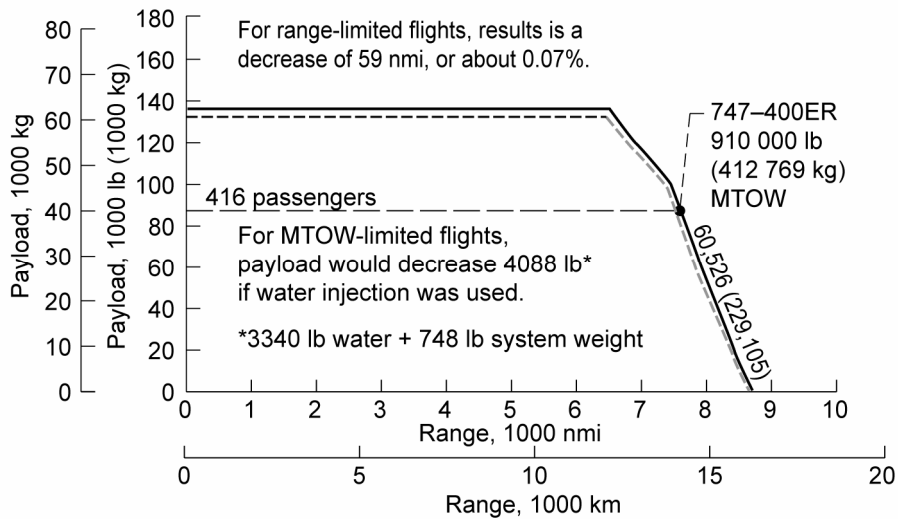

Figure 75.—The added weight of the water (if used) could reduce the payload 4088 lb or range by 59 n mi on certain flights.

When using water injection on a retrofit or current production airplane, there would be a 4088-lb payload penalty to account for the system weight and the weight of the water. However, since use of the water-injection system is optional, the operator may choose to not exercise it on flights with high payloads. Thus, in this instance, there would be a 748-lb payload penalty to account for the empty weight of the water-injection system.

3.4.11 Failure Modes.—Before the water-injection system could be considered for use in aircraft service, an in-depth analysis of its failure modes and effects needs to be conducted. Measures to assure that the system would not jeopardize the safety of the aircraft would then be designed into the final system.

Some examples of failure modes worth considering are

(1) Water-injection system fails part way into the climb and takeoff: Although the additional thrust capability of the water-injection system is not being utilized, there could be a slight increase in thrust should the water-injection system fail. Use of the water injection results in a 1.2-percent SFC penalty during takeoff. Thus, if the fuel flow rate were increased during takeoff to account for the 1.2-percent penalty, the thrust level was held constant, the water-injection system failed, and the engine FADEC controller did not correct for the water flow rate change, then the engine would deliver more thrust associated with the increased throttle setting. This would lead to a thrust asymmetry that would require action from the pilot (e.g., retard throttle on increased thrust engine and/or increase rudder action).

(2) Injection system fails off, then comes back on: As the water-injection system is cooling the turbine hot section, failure of the system would result in a rapid increase in turbine inlet temperature. If the water-injection system then started delivering water once again, and the engine FADEC controller failed to properly introduce the water slowly to the engine, then it could result in a rapid cooling action, which may result in a thermal shock to the engine hot section. Rapid temperature changes are detrimental to engine hot section life.

(3) Injection system does not fully evacuate the tanks prior to attaining freezing altitude: If the water drain system failed to fully evacuate the water tanks and the cargo hold heating system failed, then the residual water in the tanks could freeze. Water left in the pump suction feed lines could freeze and swell, which would damage the pipes and possibly the water pump wetted parts.

(4) Flow regulation system malfunction: The flow rate of the water injection is at least as important as the fuel system and therefore will need the same level of complexity in control and measurement as a fuel system (metering valve, flowmeter, pressure sensors, etc.). If the system failed to gradually introduce water to the engine during spoolup, it could lead to thermal stressing of the engine hot section. If the flow regulation system failed in the “full open” mode, then more water could be delivered to the engine than desired. The system would need to be designed such that this failure would not lead to engine flameout (possibly by sizing the water-injection pumps so that they could not deliver that much water).

(5) Heated drain mast damaged: The heated drain mast will be dispatch critical if damage to it would result in the water tanks and system not being able to drain properly.

(6) EGT margin exceedance during go around: The 747-400 must have the capability to use full takeoff rating, without the use of water injection. For “go-around” operation the dry redline margin must not be exceeded. The capability to achieve this redline rating needs to be tracked. Operators would likely be required to perform dry takeoffs at regular intervals to assess the residual EGT margin.

(7) Cargo hold (and water tanks) freeze while on the ground: If the aircraft were serviced with water during freezing atmospheric conditions and the cargo doors were left open for an extended period of time and the ECS system were not engaged or was inoperative, the water in the tanks could freeze and damage the tanks. If the aircraft then took off, it would take an extended amount of time to drain the water lines and the tanks while the frozen water melted. If the tanks ruptured from the freezing water, the water would then drain into the lower cargo hold, necessitating repair and inspection of the tank as well as the insulation blankets and any other affected system.

(8) Introduction of contaminated water: The water refill service system is anticipated to contain two water contamination sensors. However, if both sensors failed and the water conditioning system failed and the tap water introduced into the tank from the airport supply system was of poor quality, the contaminated water would result in rapid deterioration of the engine hot section and require a sooner overhaul.

(9) Single failure of water quality’s impact on all engines: If contaminated water was introduced into the aircraft (per number 8 above), then all of the engines would be affected.

(10) Water nozzle failure impact on pattern factor: Should the combined fuel and water nozzle fail, a nonuniform water spray (or fuel spray) would adversely impact the thermal gradient pattern factor, which would reduce the engine hot section life.

(11) Engine water shutoff drain valve failure: If the engine water drain valve should fail in the closed position, the water manifold would remain filled with water. If the aircraft were then to be parked overnight in a cold climate, the water could freeze and damage the water pipes. If the valve were to fail in the “open” position, then the water flow to the engine fuel/water nozzles would be decreased. This would lead to a higher thrust level and higher turbine inlet temperature, similar to scenario number 1 above.

(12) Water tank drain valve fails open and several tank vents become simultaneously blocked: In this scenario, a pressure imbalance could occur between the interior of the lower ambient pressure water tank (because the drain valve to the outside is stuck open) and the higher pressure surrounding the tank from the pressurized cabin. If the differential became sufficiently high, the water tank would collapse. When the airplane landed and if the damage was undetected, the tanks might then be attempted to be refilled, which would result in the lower cargo hold becoming flooded, similar to the water freezing scenario number 7 above.

Each of these failure modes and effects, and others not yet thought of, will need to be addressed to make sure the water-injection system is reliable and will not present any safety issues to the airplane.

3.4.12 Value of Water Injection.—Four different models were used to compare the relative value of the technology: (1) a BCA original equipment manufacturer (OEM) business model that strictly evaluates the return on investment (sec. 3.4.12.1), (2) a BCA technology valuation model that gives credit for environmental benefits (sec. 3.4.12.2), (3) a customer airplane operating cost model (sec. 3.4.12.3), and (4) a Boeing Phantom Works trade study model (sec. 3.4.12.4).

Each of the models evaluated water injection for the following three scenarios: (1) as a retrofit kit for a 747-400ER airplane already in service, (2) for an updated design to a current production 747 aircraft, and (3) for a newly designed engine and 747-sized airframe.

In all of the business case scenarios studied, the results were judged to be of poor value if the operator or OEM did not recover (in some way) their investment. The models should be used to compare the relative value between the implementation scenarios. Further, more in-depth system design and analysis would be required to provide absolute values that have higher confidence. However, all four models provided the same outcome and suggested that the retrofit scenario would be very costly to implement while the newly designed airplane was the best value. The new production airplane scenario was slightly positive.

3.4.12.1 OEM Business Model: Ideally, to assure successful implementation, a new environmental technology would not only offer environmental benefits, but also be of some financial value to both the manufacturer and the end user. In one or two of the following three implementation scenarios to be discussed, water injection may be able to satisfy these rare simultaneous goals.

As illustrated in figure 76, achieving a positive net present value (NPV) for water injection involves selling enough water injection units at a reasonable profit to recover the nonrecurring cost of developing the technology. An additional value to the OEM could be the potential to sell more aircraft to customers whose operations are being constrained by airport emission restrictions.

The nonrecurring costs are associated with design, tooling, system testing, and certification of the water-injection system. As shown in figure 77, these costs are estimated to be quite substantial and can run upwards of \$70 to \$75 M for the retrofit and production aircraft cases. This is largely due to the associated testing and certification costs. Namely, the engine manufacturer would have to conduct special engine durability, operational, and certification tests of the water-injection system. The airframe portion would also have to undergo these tests and certification.

Normally, for a new airplane design, development and certification tests for a specific technology would be conducted during the certification of the entire airplane and therefore the incremental costs of testing the water-injection system would be small. Therefore, the nonrecurring costs for the new airplane design case shown in figure 77 are substantially less as they are mostly made up of engineering design hours and not the aforementioned special testing and certification costs.

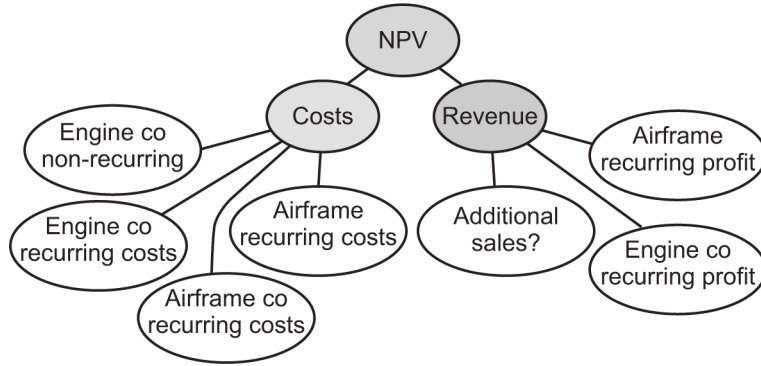

Figure 76.—The OEMs will have to offset nonrecurring costs with projected revenue in order for NPV to be positive.

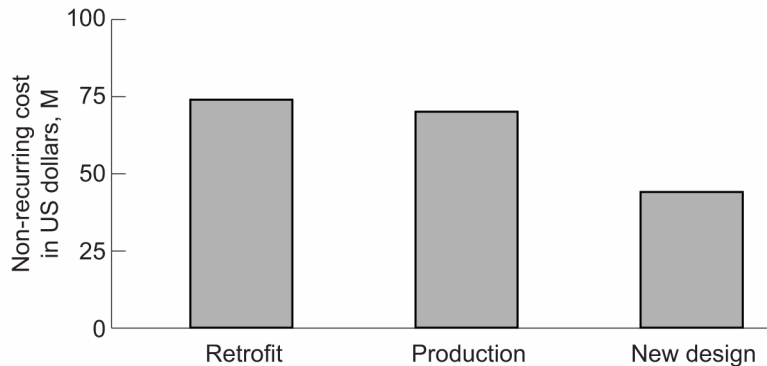

Figure 77.—Nonrecurring development costs will be quite high for the retrofit water-injection system.

Recurring costs to the OEM are those related to purchasing the materials and equipment for each water-injection system (e.g., tubes, pumps, valves, tanks, etc.).

The recurring costs to the OEM are also very high for the retrofit case. This is due to the fact that many costly engine parts (e.g., fuel nozzles) on the in-service engine would need to be replaced with retrofit parts while a new engine would simply incorporate the water-injection design into the existing equipment.

The recurring cost to the OEM would be about the same for either the production airplane or the newly designed airplane. These are indicated in figure 78 by the bars titled “Recurring cost to OEM.”

The number of water-injection systems that are anticipated to be sold will affect the ultimate sales cost. This is due to the need to recover the OEM’s nonrecurring development costs. Thus, a potential market for water-injection kits was estimated and the percent of market capture was calculated at 50 percent. Error bars indicate market capture rates from 25 to 100 percent.

For the retrofit case, there are approximately six hundred 747–400 series aircraft presently in service. Their average age is 9 years old. The retrofit kit would only be installed in aircraft that are undergoing major overhaul. To do otherwise could require replacement of the nozzle guide vanes on some engine models, which might add another ≈\$1 M to the kit. For this study, it was estimated there could be a potential 150 water-injection kits sold. Older aircraft were not considered as they were too close to retirement for this expensive upgrade.

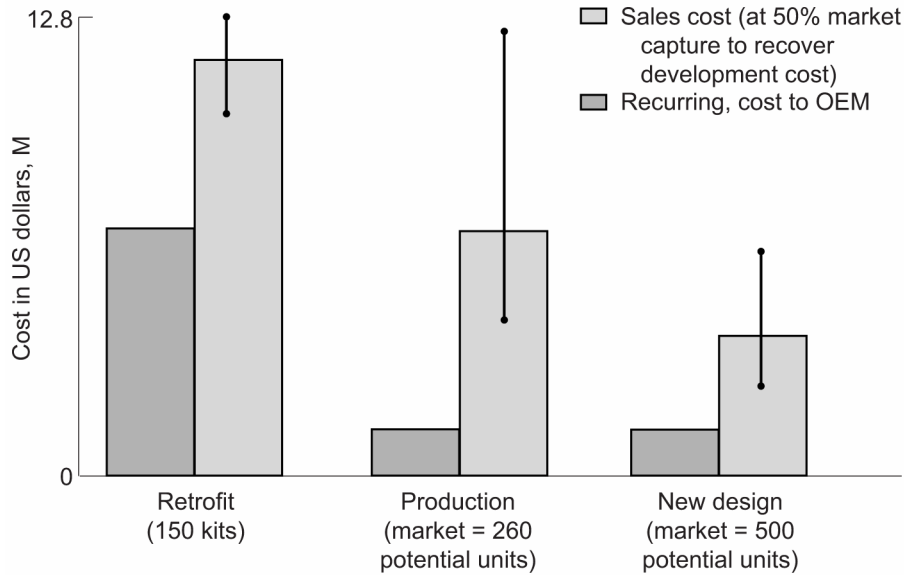

Figure 78.—Retrofit water-injection kit has high nonrecurring (fig. 77) and recurring costs with small potential market, which drives up sales cost.

For the 747 production aircraft case, a very high level estimate of 260 water-injection systems was used. The cost shown was also based on a market capture of 50 percent with error bars showing ranges from 25 to 100 percent of the potential market.

Lastly, for a newly designed airplane scenario, more water-injection units could be sold as this airplane would conceivably be in production for a much longer period.

To calculate the retail sales cost of the water-injection system, production time lines were set for each of the scenarios. For example, the retrofit scenario had a relatively short duration of 5 years in which all of the candidate airplanes would be retrofitted. The nonrecurring cost would need to be recovered over each of the time periods and this is added to the OEM recurring cost of the equipment plus a cost-escalation margin. Given these assumptions, the costs of the kits are illustrated in figure 78 by the bars titled “Sales cost.”

For the retrofit case, the high OEM recurring cost, high nonrecurring development cost, and a small potential market makes the cost of the water-injection system in the \$2.5 M range per airplane.

The sales cost for the production airplane water-injection case is substantially less because the recurring costs are less (fuel nozzles do not have to be replaced). Since the kit costs are less, there is a higher probability that more customers would be interested in such an option. Thus, the sales cost of such a unit could be in the \$1 M range if more than 50 percent of customers ordered the option. Given the associated risk of the project, this scenario only makes for a fair business case.

For the newly designed airplane/engine scenario, the water-injection kit costs are substantially less than the production airplane since there is a larger potential market. For this case, the water-injection systems might cost in the \$750 K range. As this scenario makes the best business case for an airplane operator (discussed in next section), it was thought that there would be a good chance for the OEM to sell enough kits to recover the nonrecurring development costs. This reduces the program risk and therefore delivers an acceptable business case for the OEM (table XI).

TABLE XI.—WATER INJECTION RETROFIT KITS MAKE A VERY POOR BUSINESS CASE BUT ARE AN “OK” BUSINESS CASE WHEN INCORPORATED INTO A NEWLY DESIGNED LARGE AIRPLANE

Type of installation (on a large aircraft)	Retrofit kit	Production airplane	New airplane design
Estimated potential market	150	260	500
System cost (each)	\$2.2 to \$2.9 M	\$860 K to \$2.6 M	\$575 K to \$1.4 M
Chance of sales	Poor	Unknown	OK
Business case	Very poor	Marginal	OK

When considering the attractiveness of the technology to the customer, the OEM development costs, and the airplane operating cost impact, an overall quantitative business case can be made for water injection. Figure 79 shows the business case for water-injection technology for the three implementation scenarios (retrofit, production, and new airplanes). It shows that the retrofit case provides a negative value, while the production airplane could break even when slightly more than 25 percent of the airplanes sold incorporate the kit. The newly designed large airplane shows a positive business case.

3.4.12.2 Technology Value: When evaluating an environmental technology strictly from a monetary “return on investment” viewpoint, the long-term benefits that may be more intrinsic to the long-term survival of the company (and possibly planet) are often not accounted for. Therefore, a second business model is presented that gives credit for environmental benefits.

Figure 80 provides a comparative value analysis of the three water-injection implementation scenarios. Again, the retrofit scenario had the least value while the new airplane design had the highest value.

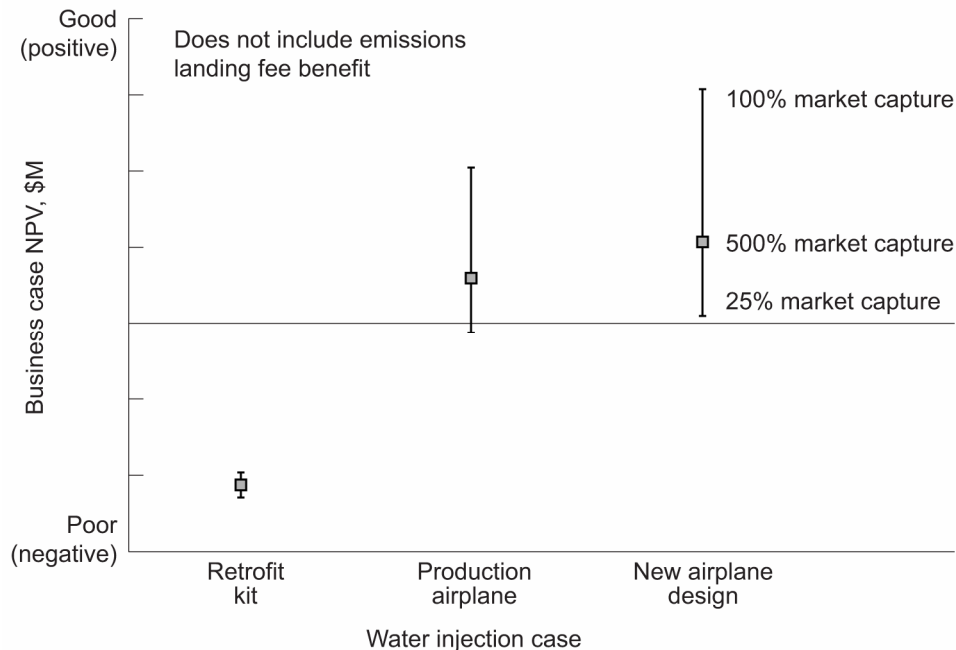

Figure 79.—Retrofit case does not make a good industry business case, but other scenarios may provide a positive NPV for the technology.

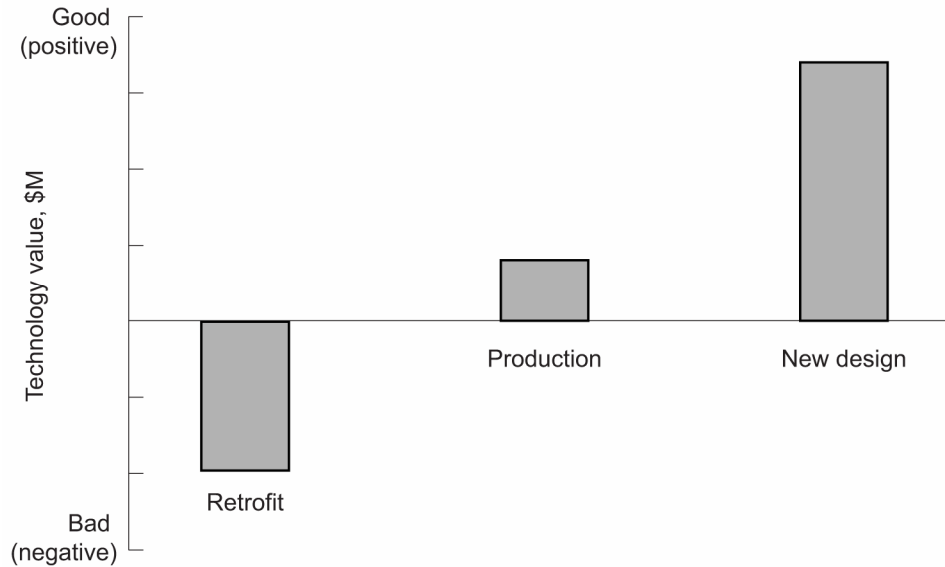

Figure 80.—Technology value analysis, that includes credit for environment, shows similar trends to the OEM business case in figure 79.

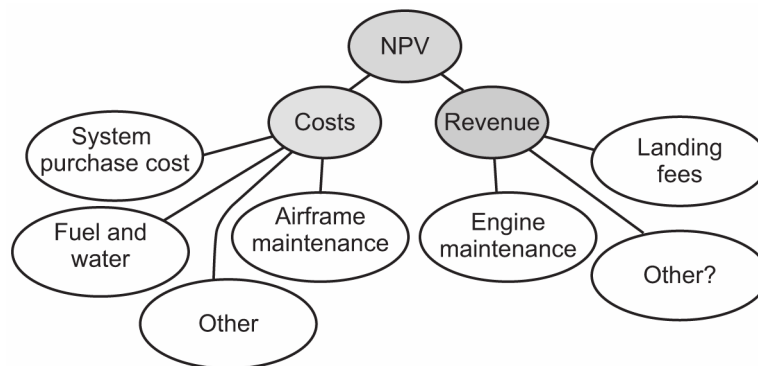

Figure 81.—Airplane operators will most likely need to balance the costs of water injection with revenue.

3.4.12.3 Value to the Operator: The third value model evaluates the value of water injection from an airplane operator standpoint. This model includes the capital cost of purchasing the water-injection system, the operating costs of the system, the cost of lost payload capability, and the anticipated engine maintenance savings that would come from the turbine life improvements identified in section 3.4.6.

A few (mostly European) airline operators would most likely be interested in the environmental benefits that water injection has to offer. They might be willing to pay for some inconvenience and cost of the system. However, most airlines will be driven by the economics of water injection. Like the OEM business case, these operators will want to assess the costs of water injection versus any derived revenue in order to see if the system offers a positive NPV for them.

3.4.12.3.1 Operator Costs: The costs that an airline operator would incur with the water-injection system are for purchasing the system, maintaining it, filling the system with conditioned water, the fuel penalty of having to carry the added weight, and the loss of payload capability (about four passengers when water injection is not used).

Preliminary system costs were calculated and included (1) the amortized cost of purchasing the water-injection system, (2) the cost of the system, (3) airframe maintenance costs that were scaled from historical TWA data, (4) the personnel and truck rental costs to fill the airplane with water, (5) the cost of the demineralized conditioned water (which is substantially less expensive now due to new reverse osmosis systems), (6) cruise fuel penalty from having to carry 748 lb of system weight (7) the takeoff fuel penalty from the 1.2 percent increase in SFC; and (8) miscellaneous costs that included the potential revenue loss for the decreased payload.

The penalty for loss of payload capability, from carrying the added 748 lb of system weight, can be reduced for a new airplane design. Namely, the airplane's operating empty weight was increased to account for the increased weight of the water-injection system and maintain the airplane's same payload capability. However, there is still some added cost associated with this scenario as heavier aircraft then have higher landing fees, higher pilot salaries, and poorer fuel efficiency. These costs were all taken into account for this scenario.

Cost of purchasing conditioning the water to the airplane operator, and its delivery, was also included in the calculations. The previous study (ref. 1) provides detail on these. It was assumed the airplane operator would incur water conditioning costs that are in-line with current industrial gas turbine user rates (ref. 8) as well as standard accepted airplane servicing rates (ref. 26). In some instances, there could be substantial airport infrastructure cost, but these would most likely be borne by the airport if they wanted the operator to use the conditioned water for emissions benefits (ref. 27).

It should be noted that the highest operating unit cost was for the money or interest that the operator would pay to purchase the water-injection system. This analysis used a standard business value of 16.7 percent to calculate the cost, which may be conservative and would then unduly penalize the operating economic analysis.

Offsetting these costs will be the revenue derived from engine maintenance cost savings and in some cases, emissions landing fees. These are described next.

3.4.12.3.2 Operator Revenue: Usually, one must look beyond the immediate short-term financial costs to appreciate the long-term sustainability that environmental technologies can offer. Still, even if the environmental benefits of water injection are dismissed, this technology may be able to also offer short-term financial benefits. Revenue can be derived from engine maintenance savings and emissions-based landing fees.

Airports in Sweden, Switzerland, and London have emissions-based landing fees. Other airports are also considering implementing emissions-based landing fees. Sweden has the highest emissions-based landing fees and figure 82 shows these for some aircraft. The varying fee levels are related to the different types of engine makes that can be on the same airframe and are not shown. The figure also shows the fee that the study aircraft with water injection would pay. For the 747 study airplane, an operator would save \$198.00 per landing.

The engine maintenance cost savings for water injection are difficult to estimate. These costs are also considered competitive information by the engine companies, making data gathering difficult. However, the following discussion shows cost trends that are ultimately validated by a single \$22/hr/engine number provided by Pratt & Whitney for the PW4062 engine.

Each engine make and model typically has a different reliability record; some engines experience more required maintenance in specific components than others. However, the hot section of an engine does tend to require a significant share of maintenance when compared to other components. Figure 83 illustrates the engine removal rates over a year for a 1980's vintage engine (A) and the newest 1990's designed engine (B) for two different manufacturers. It shows that hot section components account for between 25 and 40 percent of the reason engines are removed from service. Combustors appear to make up a very small part of the engine removal pie.

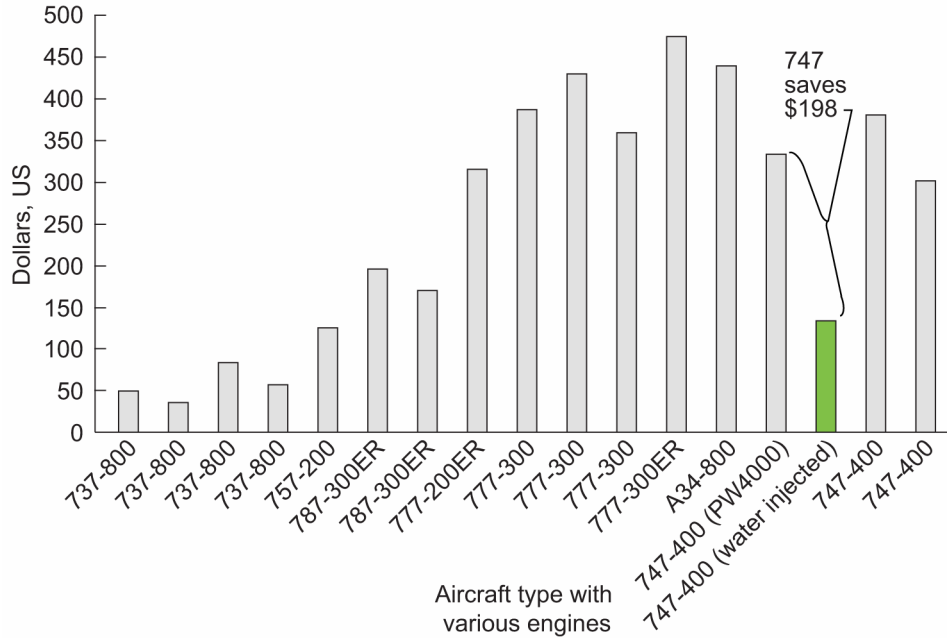

Figure 82.—Water injection would save a 747 operator \$198 on Swedish-based emissions landing fees.

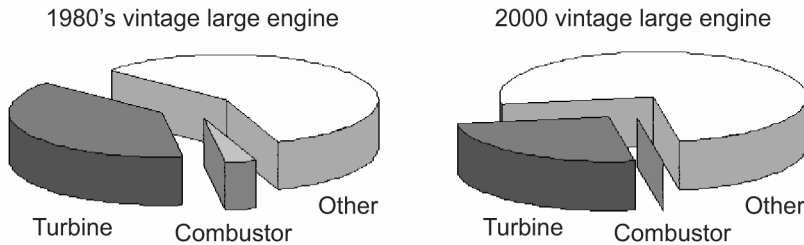

Figure 83.—Turbine-related engine removals still account for a sizable portion of the reason engines are removed from service for maintenance.

For engines that experience higher removal rates due to turbine blade thermal distress, water injection would no doubt be of more value.

For whatever reason an engine is removed from service, the turbine then often also receives attention, which contributes a significant portion towards the overhaul cost. Typically, the engine hot section account for 60 percent of engine maintenance costs (ref. 28).

The Cash Airplane Related Operating Cost (CAROC) for the 747-400ER was used to estimate the engine maintenance cost savings of the water-injection system. Figure 84 illustrates the CAROC breakdown for this airplane on a 3000 n mi mission and highlights the engine maintenance portion.

Using the 60 percent turbine cost factor, the 29 percent hot section life improvement estimated by P&W, and the above 747 airplane cash airplane operating costs, the \$22/hr/engine number provided by Pratt & Whitney is validated.

3.4.12.3.3 Operator Cost/Benefit Analysis: Tallying the CAROC is a common method for evaluating the worth of a technology to the airplane operator. Water injection provides a 1.1 percent reduction in CAROC. However, CAROC does not include the cost of the system, which is included in the airplane cost and reflected in the Total Airplane Related Operating Cost (TAROC). TAROC can be very difficult to calculate as the cost of the airplane and financing method will vary between operators. Therefore, a

modified CAROC approach, that includes the cost of the system, is used in this study to evaluate the worth of water injection to the operator.

Figure 85 shows a breakdown of the most optimistic business case for water injection costs on a newly designed airplane and the savings that an airline operator might experience (expressed as a percent of CAROC). As shown below, the cost savings from the reduced engine maintenance is anticipated to more than offset the added costs of purchasing and maintaining the water-injection system. It is estimated that an operator would experience a 0.65 percent reduction in operating cost for the system on a newly designed airplane and engine.

For operators who may experience emissions-based landing fees, the savings increases to 1.1 percent as the operator is now saving an additional \$198 per landing due to the reduced NO_x emissions.

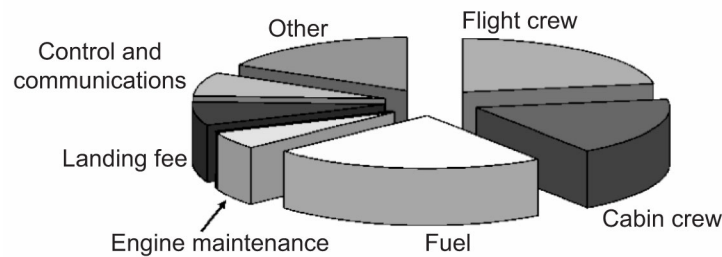

Figure 84.—Engine maintenance is a significant portion of CAROC.

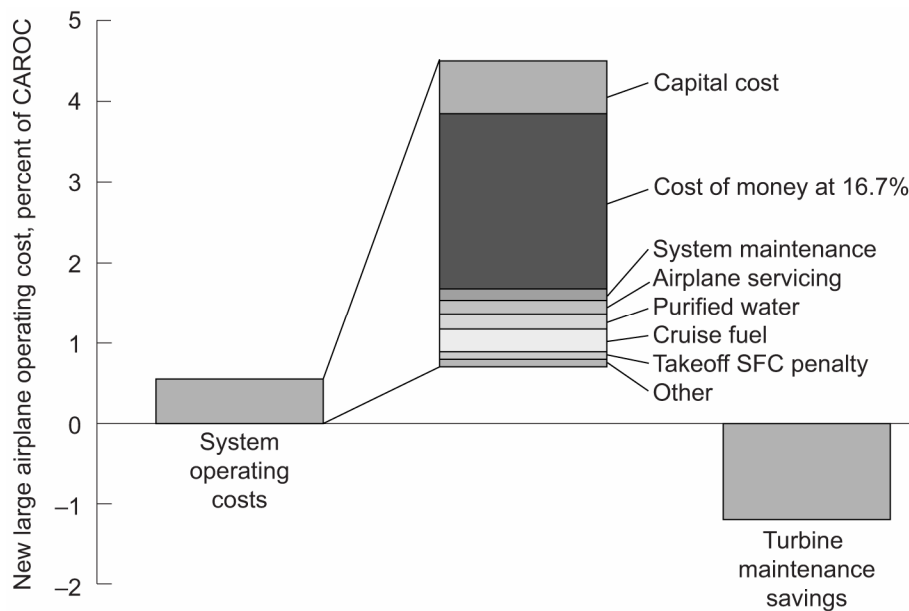

Figure 85.—Under the best circumstances, savings from turbine maintenance may offset water-injection costs to provide a 0.65 percent savings to the airplane operator.

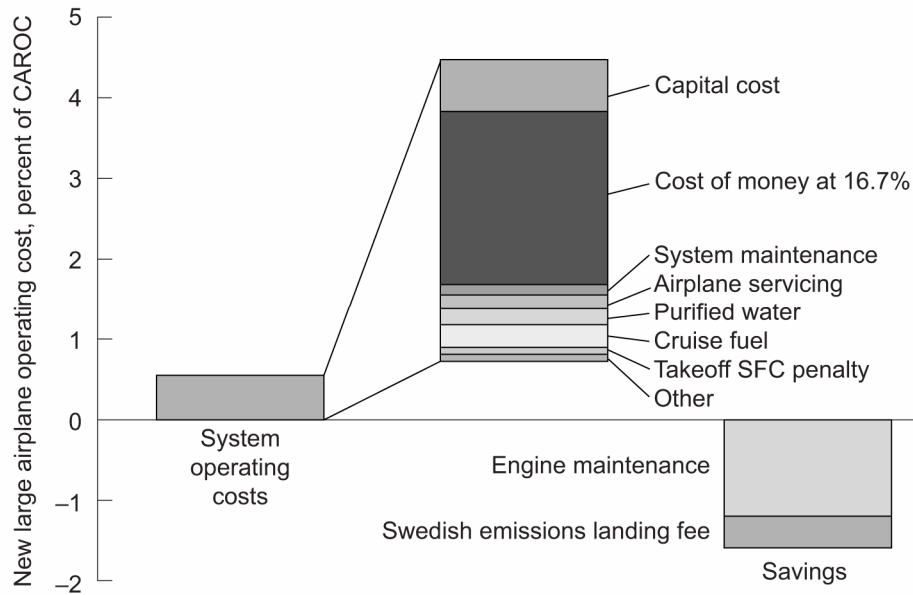

Figure 86.—If emissions-based landing fees are included, savings will increase to 1.1 percent on airplane operating costs.

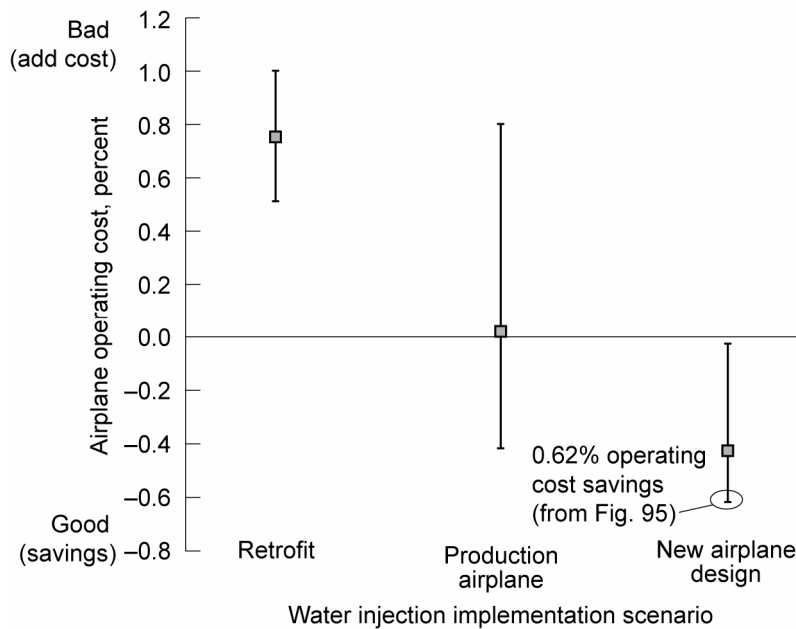

Figure 87.—Retrofit water-injection kits would cost airplane operators money but would save money on a newly designed airplane.

These values were for the most optimistic estimates, given a zero NPV of the technology for the OEMs. When factoring in OEM profits and market risks, the business case deteriorates. How the water-injection system affects airplane operating cost is shown in figure 87 for the three implementation scenarios. Error bars show how the sales price of the water-injection system, which is based on the number of units sold, will affect the operator's costs.

Clearly, the retrofit scenario is cost prohibitive. This is due to the small number of kit sales (150), high nonrecurring costs (\$74 M), shorter life span of the airplane to recover kit costs (assumed airplane life is half used) and the high cost (16.7 percent) for a pricey water-injection kit (\$2.2 to \$2.9 M).

The water-injection system for the production airplane scenario warrants further investigation. If a sufficient quantity of systems were sold at minimal cost, it could prove worthwhile for reducing airplane operating costs. To explore this scenario requires discussions with airplane operators to more accurately gauge the potential market for the technology.

The operating cost-reduction potential for the new airplane scenario is favorable. With these types of potential savings, the technology could be desirable enough to generate a market for water injection based on engine maintenance savings alone. The emissions benefits will then be quite attractive. For example, when one considers the amount being spent by industrial customers around the world to reduce NO_x emissions, it can vary from the \$5,000 per ton range to approximately \$60,000 per ton for applications in European cities. If the water-injection system can save airline customers on operating costs, then the 80 percent takeoff reduction of NO_x emissions will be free or there will be even a negative cost as illustrated in figure 88.

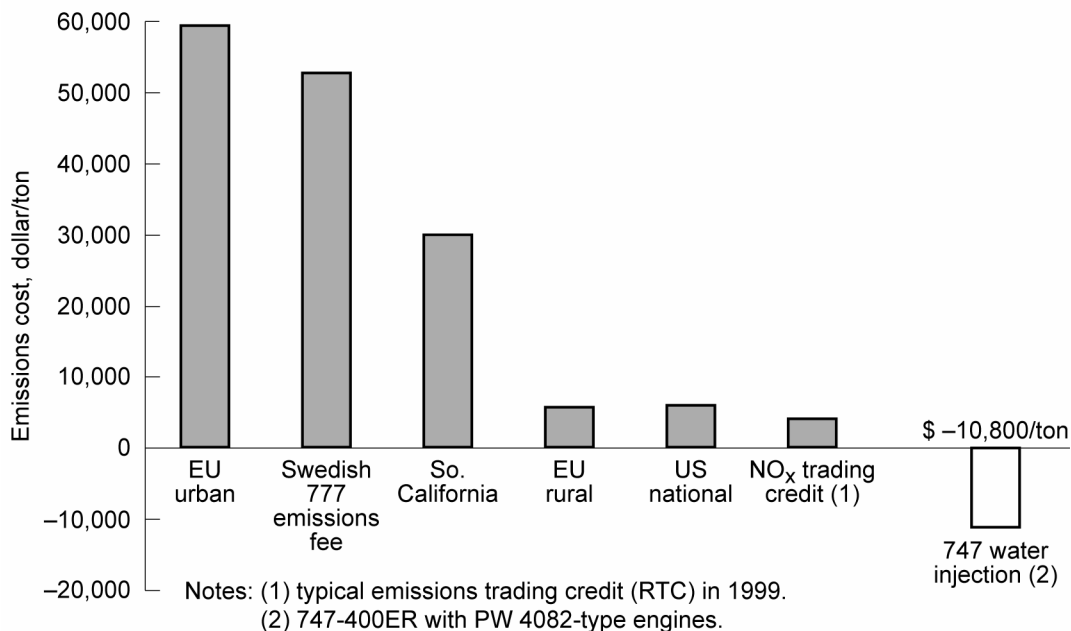

Figure 88.—Airplane NO_x emissions reduction cost is attractive when compared to what other sectors are paying to reduce emissions.

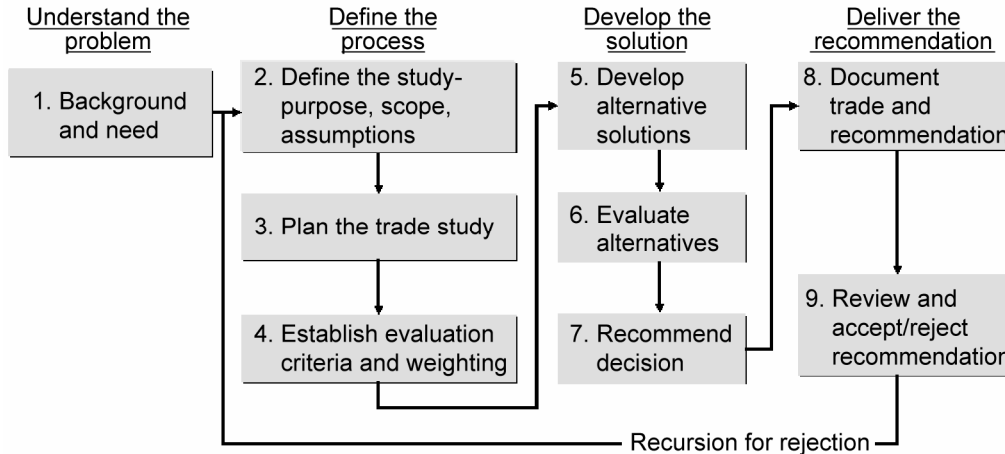

Figure 89.—Boeing Pratt & Whitney trade study model was one of four used to rank the value of the water-injection system.

3.4.12.4 Boeing Phantom Works Trade Model: The fourth model used in this study was originally developed to assess alternatives and decide on a preferred approach. The process flow is shown in figure 89.

With regard to the figure above, the need, purpose, scope, assumptions, and plans have already been discussed. The evaluation criteria and weighting factors for this study are illustrated in the table below. The weighting factors were calculated through a Boeing proprietary code, based on ranking the importance of each criteria against the others (e.g., safety vs. range, safety vs. SFC, etc.).

TABLE XII.—EVALUATION CRITERIA AND WEIGHTING FACTORS USED FOR TRADE STUDY

No.	Evaluation Criteria	Weight
1	Safety	0.428
2	Range/payload	0.147
3	SFC	0.135
4	Maintenance	0.103
5	Environmental benefit	0.055
6	Acquisition cost	0.05
7	System simplicity	0.043
8	Airport logistics	0.022
9	Development costs	0.018
	Total	1.000

Six scenarios or cases were evaluated to rank them against one another using the weights established in the table above and the degree to which each case is able to satisfy the evaluation criteria. The matrix below describes the six cases.

Of all the cases evaluated, the water misting design on a new airplane (option F) had the highest score. This is assuming that the earlier-mentioned engine technical challenges could be overcome. The second choice would be for the combustor water-injection system on a newly designed airplane (option C). Figure 91 shows high-level results of this trade study.

	Retrofit airplane	Production airplane	New airplane design
Water injection	Case A	Case B	Case C
Water misting	Case D	Case E	Case F

Figure 90.—Trade study cases evaluated.

Criteria	Weight	Option A	Option B	Option C	Option D	Option E	Option F
Safety	0.428						
Range/payload	0.147						
SFC	0.135						
Maintenance	0.103						
Environmental benefits	0.055						
Acquisition cost	0.050						
Engine simplicity/designability	0.043						
Airport logistics	0.022						
Development cost	0.018						
Combined score		5.312	5.448	5.748	5.483	5.583	5.883



2nd place
#1 winner

Figure 91.—Option F (water misting on new airplane design) is first choice, followed by option C (water injection on new airplane design).

Safety was the overriding weighting factor for this analysis. This criteria is very sensitive, therefore, any slight downwards variation in safety would bring the particular water-injection option into last place. It was assumed that all of the configurations would have the same level of safety.

4.0 Conclusions and Recommendations

4.1 Summary of Results

In deciding on the preferred method of injecting water into the engine, the compressor water-misting scheme had the best value. However, the combustor water-injection scheme was chosen as the preferred option since the engine manufacturer did not have a clear path to solve the associated compressor surge issues with water misting and combustor water injection offered less development risk.

Engine performance penalties and compressor operational challenges could still be expected if water injection were to be installed on existing engines as a retrofit kit. This could most likely be addressed during the design phase for a newly designed engine.

The water-injection system could achieve up to an 80 percent NO_x reduction during takeoff when a 1:1 water-to-fuel ratio is used to 3000-ft altitude. This requires 400 gal of conditioned water for a 747 airplane. Smoke emissions could possibly be reduced by up to fourfold.

With a 120 °F decrease in turbine inlet temperature, due to the cooling action of the water, the turbine life on a PW4062 engine is estimated to increase by 29 percent when takeoff thrust is held constant. For a more modern engine, the estimated life benefit would be less, ranging from 0 to 20 percent.

There is a 748-lb weight penalty to carry the water-injection system components on the 747. When the water-injection system is chosen to be operated, there would be an additional 3340 lb reduction in payload capability for the 400 gal of water. Use of the water-injection system was considered optional, so that no safety issues would arise should the system fail or the full payload capability of the airplane was needed.

Nonrecurring engineering, testing, and certification costs for water injection are less if the system is designed into a new airplane at the start of a program. These costs would escalate dramatically if water injection were to be specially designed and certified for an existing airplane as a retrofit kit. The recurring cost for the water-injection system itself is relatively minimal.

Taking into account the water-injection system operating costs and the engine maintenance savings, an airplane operator is expected to save approximately 0.65 percent in airplane-related operating costs. For operators flying into airports with emissions-based charges, operator savings could increase to as much as 1.1 percent.

4.2 Analysis of Results

Due to the high water-injection development, certification, and testing costs, as well as a 0.4 percent SFC cruise performance loss on a retrofitted engine, water injection only seems to provide an acceptable business case for use on new airplane designs.

There is disagreement within the aerospace community as to the degree of turbine life improvement, but most agree that water injection will likely extend the life of the engine hot section. This is anticipated to save an operator on engine maintenance costs.

There is also uncertainty about the degree of compressor surge margin deterioration that the LPC water misting and combustor water-injection systems would cause. This could possibly be ameliorated in a new engine design.

If these life extension questions and operational issues can be resolved, the 80 percent reduction in takeoff NO_x and possible fourfold reduction in smoke could make water injection a very cost-effective emissions-reduction technology. For airports and airplane operators whose growth is being constrained by NO_x emissions, water injection may be an attractive option.

The poor reputation of older water-injection systems, the added airplane weight of the system, and the inconvenience of having to fill the aircraft with demineralized water will be major negative issues to deal with.

Although water injection has been used for many years on older commercial aircraft and is currently used in industrial gas turbine engines, it is an unproven technology for modern aeroengines. Therefore, water injection for commercial aircraft is presently at a technology readiness level (TRL) of 3 to 4. The technology would most likely rapidly progress to TRL 9 based on the historical and industrial experience of water injection.

4.3 Recommendation

4.3.1. Suggested Action.—Based on the above analysis of results, it is suggested that future research primarily focus on removing the engine uncertainties associated with water injection. Water injection for aeroengines should be brought to a TRL of 6 by NASA. A system prototype demonstration of the technology on a new engine demonstrator would be ideal. The airframe portion of the water-injection system may be less challenging to implement, but still needs to be included to support any prototype system test of engine water injection.

As most NO_x is emitted during cruise, a study should be undertaken to see if cruise NO_x could be reduced by optimizing the combustor for this phase of flight while relying on water injection to control takeoff NO_x .

4.3.2. Future Planned Work.—It is anticipated that the airframe company(s) could work with some engine companies to agree on a “go forward” plan. This may involve getting feedback from airplane operators who would use such a system. If there is sufficient market demand, support of the technology from industry, and the findings of this report are validated by a system prototype demonstration, water injection might then be rapidly developed for future new aircraft as an emissions-reduction option.

References

1. Daggett, David L., “Water Misting & Injection of Commercial Aircraft Engines to Reduce Airport NO_x,” NASA/CR—2004-212957, Feb. 2004.
2. Sticker, Peter, Eaton Aerospace Company. Memo dated Jan. 7, 2005.
3. Bellinger, Stacy; Vennat, Jose, Argo-Tech. Memo dated Nov. 2004.
4. Eames, David, “Short Haul Civil Tiltrotor Contingency Power System Preliminary Design,” NASA/CR—2006-214059, 2006.
5. “The Jet Engine,” Rolls-Royce plc. 1986.
6. Schouse, Dale, AFRL/PRTC, Air Force Aero Propulsion Laboratory, Wright-Patterson Air Force Base, OH, 2004.
7. Becker, Arthur, et al., “Engine Company Evaluation of Feasibility of Aircraft Retrofit: Water Injected Turbomachines,” NASA Order Number NNC04QB58P, Feb. 2005.
8. Personal discussion with Bill Farmer, CH2M-Hill Company, Seattle, WA, 2004.
9. Davis, D.Y., and Sterns, E.M., “Energy Efficient Engine Flight Propulsion System Final Design and Analysis,” NASA CR—168219, 1985.
10. Zaretsky, E.V., “Weibull-Based Design Methodology for Rotating Aircraft Engine Structures,” NASA/TM—2002-211348, June 2002.
11. Halila, E.E., Lenahan, D.T., and Thomas, T.T., “High Pressure Turbine Test Hardware Detailed Design Report,” NASA CR—167955, June 1982.
12. Manson, S.S., “Fatigue: A Complex Subject—Some Simple Approximations,” The William M. Murray Lecture, 1964, Presented at 1964 SESA Meeting, Cleveland, OH, Oct. 1964.
13. High Temp Metals Inc., Technical library, <<http://www.hightempmetals.com/technicaldata.php>>
14. Military Handbook MIL-HDBK-5H: Metallic Materials and Elements for Aerospace Vehicle Structures, U.S. Department of Defense, 2003.
15. Klopp, W.D., Nonferrous Alloys, Aerospace Structural Metals Handbook, Code 4214, pp. 1–18, Sept. 1984.
16. Zupnik, T.F., “Hot Section Technology,” Pratt & Whitney, GTL Lecture Series-MIT, 1979.
17. Lefebvre, Arthur, Gas Turbine Combustion, Taylor & Francis, 1983.
18. Lefebvre, A.H., and Durrent. T., “Design Characteristics Affecting Gas Turbine Combustion Performance,” SAE Preprint 240C, also Esso Air World, vol. 13, no. 3, pp. 64–69, 1960.
19. Castaldini, C., “Evaluation of Water Injection Impacts for Gas Turbine NO_x Control at Compressor Station,” GRI-90/0124, Gas Research Institute, June 1990.
20. Hung, W.S.Y., “Accurate Method of Predicting the Effect of Humidity or Injected Water on NO_x Emissions from Industrial Gas Turbines,” ASME publication 74-WA/GT-6, Aug. 1974
21. Hendricks, R.C., Shouse, D., and Roquemore, M., “Water Injected Turbomachinery,” *The 10th International Symposium on Transport Phenomena and Dynamics of Rotating Machinery*, 2004.
22. Mongia, H.C., and Hoover, J.A., “In-situ Industrial Gas Turbine Combustion Control Technology for Ultra-Low Emissions,” ASME paper IGTI-Vol. 7, ASME Cogen-Turbo, Book No. 100333, 1992.
23. Marchionna, N.R., et al., “The Effect of Water Injection on Nitric Oxide Emissions of a Gas Turbine Combustor Burning ASTM Jet-A Fuel,” NASA Technical Memorandum, TM X-2958, Dec. 1973.
24. Discussions with AFRL/PRTC personnel, Air Force Aero Propulsion Laboratory, Wright-Patterson Air Force Base, OH.

25. Bahr, D.W., "Technology for the Reduction of Aircraft Turbine Engine Exhaust Emissions," Paper 29, Atmospheric Pollution by Aircraft Engines, AGARD CP-125, Advisory Group for Aerospace Research & Development, 1973.
26. Mutual Assistance Ground Service Agreement, Industry Accepted Rates, p. 2, 2002.
27. Meeting held on 9/24/04 at LAX with C. Lin Wang, Dennis Quiliam, David Waldner, and Gary Brown to discuss airport infrastructure issues with implementing water injection.
28. Dennis, A.J. and Cruse, T.A., "Cost Benefits From Improved Hot Section Life Prediction Technology," AIAA-79-1154, 1979.

Appendix A—Turbine Life Prediction and Material Maintenance Costs for Water Injection

Anuja Mahashabde and Ian A. Waitz
Massachusetts Institute of Technology
Cambridge, Massachusetts 02139

Abstract

The implementation of a water injection system in commercial airplane engines holds the potential for significant reductions in NO_x and soot emissions as well as improvement in the engine hot section life. Improvement in the hot section life is anticipated as water injection reduces the operating temperature of the engine components. This study focuses on analyzing the effects of water injection specifically on turbine blade life and on maintenance costs. The dominant mechanisms of failure in the turbine are identified as low cycle fatigue, creep and oxidation. Using the Universal Slopes method, a preliminary quantitative analysis of possible fatigue life benefits from water injection has been performed in this report for three representative blade materials, Inconel 625, Inconel 706 and Rene 80. For a 67 K (120 °R) change in turbine inlet temperature, the results have shown that possible life improvement ranges from a factor of 2 to 4.5 for Inconel 625 depending on the strains imposed. Similarly, life improves by a factor of approximately 1.65 for Inconel 706 and by a factor of about 3.5 for Rene 80 under thermally varying strains with the same turbine inlet temperature reduction. The results of this fatigue analysis depend strongly on the material properties and operating temperatures. A sensitivity analysis shows the trends in fatigue life estimates for varying loads and materials. Detailed analyses of the combined effects of fatigue, creep and oxidation are not feasible through a generic life model. Consequently, a brief overview of the effects of creep and oxidation is presented as found in the literature. It is seen that life estimates based on all three mechanisms are sensitive to metal and gas temperatures (internal and external to the blade) and to stress levels. Creep-fatigue interaction and the influence of temperature are demonstrated through a representative alloy, SRR99.

In addition, a maintenance cost analysis was performed to evaluate and compare benefits resulting from engine de-rate and water injection. An engine cycle program (GasTurb,) and airline data were used for this analysis to establish a correlation between changes in turbine inlet temperature and corresponding changes in costs for a typical 1970's technology mixed flow turbofan engine. This analysis proposes that water injection may achieve the same engine cost benefits as de-rate by extending the life of the turbine. Shorter range flights, with more takeoffs per day, experience larger benefits. Absolute life benefits depend on the engine cycle.

The shortcomings of these studies are also discussed and recommendations for future work are presented.

1. Introduction

Water injection is a well-established technology in the industrial power generation sector and is used for NO_x reduction as well as power augmentation. In the aviation industry, water injection has been used in the early Boeing 707 and Boeing 747 commercial jet engines for takeoff thrust boosting; however, current technology jet engines are capable of much higher power production and no longer use water injection for that purpose. Today, the technology holds the potential to improve the engine hot section life in addition to reducing NO_x and soot emissions. Data obtained from Boeing reveals that NO_x reductions of up to 80 percent are possible during takeoff when atomized water is sprayed into the combustor with a water to fuel ratio of 1:1. This corresponds to temperature reductions of approximately 67 K (120 °R) in the turbine inlet. It is assumed that a change in turbine inlet gas temperature of 67 K (120 °R) corresponds

to the same change in metal temperature. A thermal effect of this magnitude during the critical takeoff portion of the mission can have significant impacts on the turbine life.

This report quantifies the possible turbine life benefits due to water injection, expressed in terms of general trends observed in the predicted life as a function of metal temperature. The results developed are not limited to a particular type of engine or other design details such as blade geometry, but are representative and expressed in terms of generic test specimen data sets without consideration of coatings. Fatigue, resulting from cyclic loading on the components, creep and oxidation are known to be dominant failure mechanisms in the engine hot section. The turbine material properties and thermal loads vary greatly with operating temperatures. A parametric analysis of a commonly used fatigue lifing methodology is presented through this paper over a range of load conditions and using three different representative materials. Creep and oxidation life modeling requires detailed material data usually obtained experimentally for a specific material. Owing to the complex interactions between these three mechanisms and the wide range of material data needed, it is a challenging task to develop a generic model that provides good life estimates regardless of material type, loads and temperatures involved. This extends beyond the scope of the current study and thus, effects of creep and oxidation on life estimates are demonstrated as obtained through a literature review for different nickel-base alloys.

For the purposes of this report, it is necessary not only to quantify the impacts of water injection on turbine life, but also to address the potential maintenance costs benefits. Turbine inlet temperature reduction from water injection can be compared with similar reductions achieved due to engine de-rated operations. Airline data (ref. 1) available for material maintenance costs associated with de-rated operations for a 1970s technology mixed flow turbofan engine can be used to estimate the cost benefits associated with water injection. Engine cycle-deck results from GasTurb (ref. 2) are utilized in converting the 120 °R change in T_4 to a range of takeoff de-rate levels. The maintenance cost analysis is then presented in the form of percent reductions in cost for the de-rate range and for different flight times. It is important to note that while the results for the turbine life blade analysis are generic, the maintenance cost analysis is done for a specific engine based on data availability and is representative of potential cost benefits.

2. Failure Mechanisms

One of the dominant mechanisms of failure in engine hot section components is fatigue, resulting from cyclic loading of the parts. Specifically, turbine blades are subjected to high centrifugal stress levels and aerodynamic loadings at elevated temperatures in a corrosive environment. Degradation of turbine blades thus results from a combination of cyclic high stress levels, creep effects from exposure to elevated temperatures as well as environmental factors. Critical cyclic stress levels imposed for a short duration of time such as take-off correspond to low cycle fatigue failure of the hot section components.

2.1 Fatigue

Fatigue life characterization under such conditions is commonly done through total life approaches, where life is divided into two distinct regimes: crack initiation and crack propagation (ref. 3). Total life approaches are based on stress levels or strain levels usually predicting life up to crack initiation and then the propagation life to a critical crack size that is designated as failure. Depending on the operating conditions and loads imposed on the part, the total life of the part is divided between these two regimes.

2.1.1 Crack initiation life.—In the case of low cycle fatigue at elevated temperatures, material behavior is not purely in the elastic range. Under such circumstances, fatigue life is characterized in terms of the total strain range that the part is subjected to (ref. 3). The total strain amplitude is divided into its elastic and plastic strain amplitudes given by:

$$\frac{\Delta\varepsilon}{2} = \frac{\Delta\varepsilon_e}{2} + \frac{\Delta\varepsilon_p}{2} \quad (1)$$

$$\frac{\Delta\varepsilon_e}{2} \text{ – elastic strain}$$

$$\frac{\Delta\varepsilon_p}{2} \text{ – plastic strain}$$

Based on log-log plots in terms of cycles to failure and stress levels of experimental data, the elastic strain can be expressed through the Basquin equation (ref. 3) as:

$$\frac{\Delta\varepsilon_e}{2} = \frac{\sigma'_f}{E} (2N_f)^b \quad (2)$$

- E Young's modulus [Pa]
- σ'_f fatigue strength coefficient [Pa]
- b fatigue strength or the Basquin exponent (ranging from $-0.05 \sim -0.12$)
- N_f number of cycles to crack initiation

Similarly, according to the Coffin-Manson relation, the plastic strain component is expressed as:

$$\frac{\Delta\varepsilon_p}{2} = \varepsilon'_f (2N_f)^c \quad (3)$$

- ε'_f fatigue ductility coefficient
- c fatigue ductility exponent (ranging from $-0.5 \sim -0.7$)

Combining equations (2) and (3) and substituting into equation (1) gives:

$$\frac{\Delta\varepsilon_{total}}{2} = \frac{\sigma'_f}{E} (2N_f)^b + \varepsilon'_f (2N_f)^c \quad (4)$$

2.1.2 Universal Slopes method.—Although the Coffin-Manson relation was developed for crack initiation life, Manson, in his paper (ref. 4) shows that this relation can be used to predict life up to actual failure or specimen separation. Based on experimental results obtained from 29 specimens, his results propose a modified version of equation (4) for fatigue life prediction. This method is commonly known as the Universal Slopes method and is given by:

$$\Delta\varepsilon_{total} = 3.5 \frac{\sigma_{ult}}{E} N_f^{-0.12} + \varepsilon_f^{0.6} N_f^{-0.6} \quad (5)$$

- σ_{ult} ultimate tensile strength [Pa]
- ε_f true fracture ductility (from monotonic tensile tests)

$$\varepsilon_f = \ln(1 + \%elongation) \text{ or } \varepsilon_f = \ln\left(\frac{1}{1 - RA}\right)$$

RA area reduction of stressed component (test specimen)

This method puts forth average values for the exponents in equation (4), based on experimental results, which are not specific to any material and can be used at a preliminary design stage life analysis. Accordingly, at constant strain, increasing σ_{ult} and ductility and decreasing E enhances life. Increasing strain degrades life. In the Manson study, 99.5 percent of the experimental life data falls within a factor of 20 of the predicted life.

For the analysis herein, nickel-base superalloy turbine blade materials, Inconel 625, 706 and Rene 80 are used where the materials properties are obtained from the technical library from High Temp Metals Inc. (ref. 5), the Military Handbook (ref. 6) and the Aerospace Structural Metals Handbook (ref. 7). The damped Newton-Raphson method is used to solve equation (5) for N_f .

(i) *Elastic life*: If only the elastic portion of the Universal Slopes method is used, the life estimate can be solved as:

$$N_f = \left(\frac{\Delta \varepsilon_{tot} E}{3.5 \sigma_{ult}} \right)^{-1.12} \quad (5a)$$

The life estimate is dependent on the ratio of temperature dependent material properties and the strain value.

(ii) *Plastic life*: Similarly, if only the plastic part of the method is used, the life is evaluated as:

$$N_f = \varepsilon_f (\Delta \varepsilon_{tot})^{-0.6} \quad (5b)$$

Here, the life estimate is only a function of the ductility and the strain value used.

2.1.3 Stress level estimation.—In order to obtain life estimates from the Universal Slopes method, the total strain range imposed on the blade needs to be approximated. The analysis is performed in two ways: keeping the strain level constant and varying temperature dependent material properties as well as by varying the strain level with temperature.

(i) *Total strain range estimation*: For the analysis, it is desirable to observe the effects of total strain levels on the life estimates. The total strain is selected such that the respective stress level is limited from 40 to 80 percent of the ultimate tensile strength at a given temperature level. This corresponds to applying a design factor of safety of 2.5 to 1.25 respectively. The life cycles to failure are then acquired from equation (5), keeping the strain level constant and varying material properties due to temperature changes.

(ii) *Temperature dependent strain range*: It is expected that as the operating temperature of the blade increases the stress level increases and there are variations in the total strain as well. These strain variations are expressed through thermal stresses only. This represents in-phase thermo-mechanical loading where the thermal and mechanical loads on the part are increased or decreased simultaneously. Since the centrifugal stresses are not actually calculated, the thermal stress levels are permitted to be higher than expected such that the total stress level is within a factor of safety of 1.25 to 2.5 of the ultimate strength.

(iii) *Thermal stresses*: The thermal stresses are given by:

$$\sigma_{th} = \alpha E (T - \bar{T}) \quad (6)$$

α [K^{-1} or R^{-1}] is the thermal coefficient of expansion of the blade material and E [MPa or kpsi] is the modulus of elasticity. The thermal stresses arise from local temperature gradients that result in non-uniform expansion causing stresses in the blade.

3. Material Maintenance Cost Estimation

It is common practice to operate at de-rated thrust levels at takeoff as well as during climb in order to achieve lower operating temperatures. This usually increases takeoff time, however, the engine maintenance cost benefits generally outweigh the disadvantages. According to a major airline, de-rated takeoffs are performed for 67 to 95 percent of flights depending on factors such as aircraft type and weight, weather conditions and runway length, with typical de-rate levels ranging from 5 to 25 percent (ref. 1).

De-rated operations result in lowered temperatures in the engine hot section leading to extended engine life. Data obtained from an airline company shows maintenance material cost reductions due to de-rated operations (ref. 8). This data only reflect basic causes for maintenance including FOD, but does not include negligence or labor costs. De-rate levels can be correlated with reductions in turbine inlet temperature to establish a relationship between cost reductions and turbine inlet temperature. Since water injection also results in lowered turbine inlet temperatures, potential maintenance cost benefits are likely. The airline maintenance cost data is used to estimate cost benefits possible due to water injection.

In order to connect de-rate levels to changes in turbine inlet temperature, cycle deck analyses are performed in GasTurb (ref. 2) to observe the influence of several parameters on the off-design relationship between thrust and T_4 . Different engines cycles are analyzed through GasTurb (ref. 2) by varying critical parameters such as the OPR, BPR, T_4 , component polytropic efficiencies and the mass flow. Linear trendlines are fitted through the cycle deck data obtained. The slope of the trendline for each cycle is the ratio of change in the net thrust to change in T_4 and has the units of [kN/K]. The average, minimum and maximum values of this slope can be determined from the cycle data and used to relate the 120 °R change in T_4 to a corresponding change in thrust. For a reduction of 120 °R or 66.67 K in T_4 from water injection, the change in thrust is found by:

$$\Delta \text{Thrust (de-rate)} = (66.67 \text{ K}) \times (\text{slope kN/K}) \quad (7)$$

The percent de-rate is calculated simply by dividing the Δ Thrust values by the takeoff thrust for each cycle and then averaging the results. This percent de-rate is assumed to be the takeoff de-rate and is then combined with the airline data to obtain maintenance cost reductions due to water injection.

4. Results and Discussion

The results are presented for low cycle fatigue as obtained from the Universal Slopes method for the three different materials used: Inconel 625, Inconel 706 and Rene 80. The differences in life estimates for the cases of elastic life, plastic life, and total life with constant strain as well as temperature dependent strain are demonstrated for Inconel 625. Results for Inconel 706 and Rene 80 are only shown for the case of total life with temperature dependent strain to illustrate the variation in life estimates based on material selection. For creep and oxidation life estimates, a brief summary of literature search results is provided. Creep-fatigue life estimates are presented for SRR99 (ref. 9) and life estimate variations based on temperatures and stresses are also demonstrated.

Using the airline maintenance cost data associated with de-rate levels (ref. 8), potential material maintenance cost benefits from water injection for a 1970's technology mixed flow turbofan are also presented.

4.1 Fatigue Life Estimate

The Universal Slopes method was used to determine low cycle fatigue life in the hot section components. Owing to a lack of detailed information about the component geometry, loads and operating conditions, the life prediction methodology selected was based primarily on material behavior with

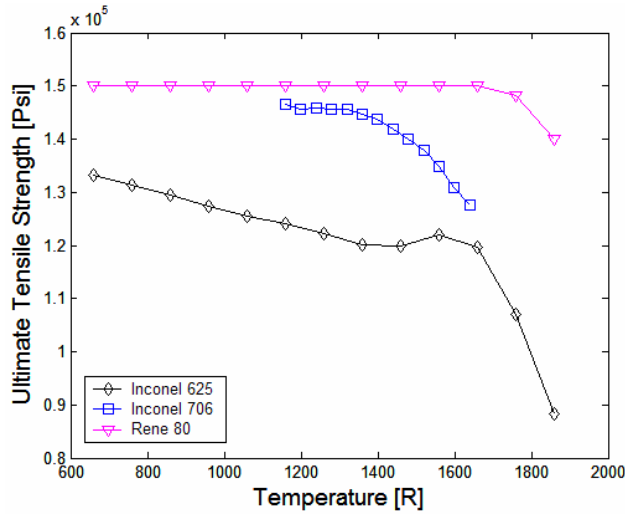

Figure 1.—Young’s modulus vs. temperature.

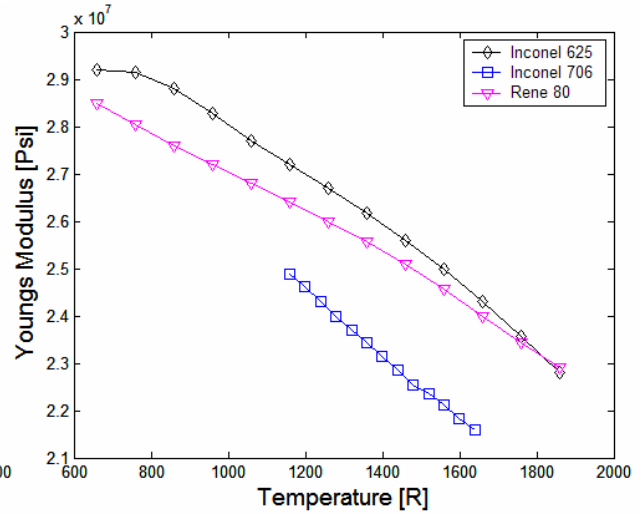

Figure 2.—Ultimate tensile strength vs. temperature

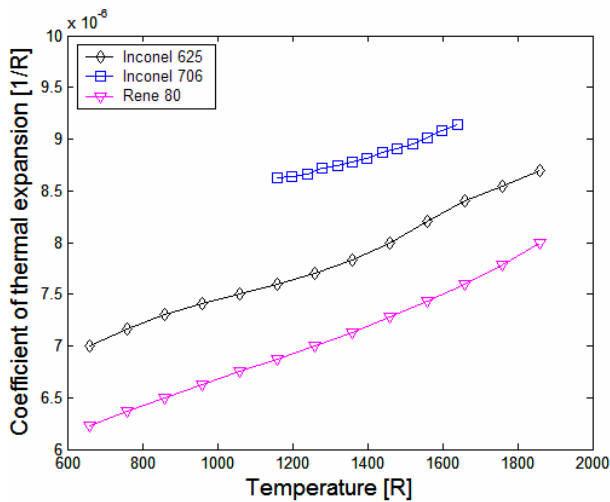

Figure 3.—Ductility vs. temperature.

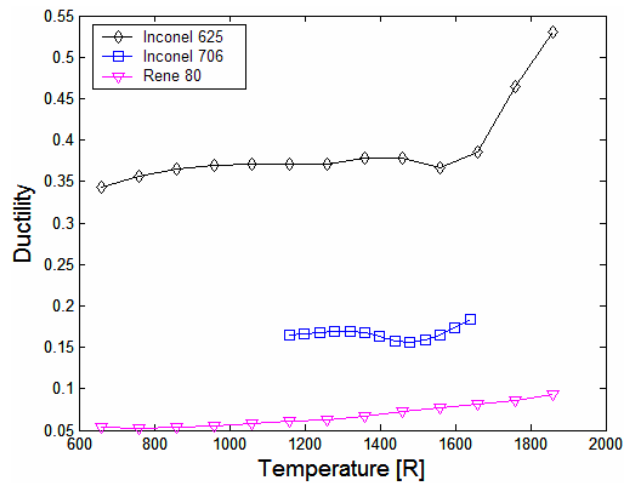

Figure 4.—Coefficient of thermal expansion vs. temperature.

varying temperatures. Three different representative alloys were selected for this analysis. Figures 1 through 4 compare the relevant mechanical properties of these materials (refs. 5, 6, and 7).

These material properties show similar general trends for varying metal temperature levels with differences in the actual magnitudes and it is expected that this will be reflected in the life estimates obtained.

4.1.1 Inconel 625.—The life predicted by the Universal Slopes method varies greatly depending on several factors such as the material used, whether the elastic or plastic portion of the equation is used, the strain levels, strain dependence on metal temperature and so on. Some of these effects are illustrated in the following discussion for Inconel 625.

For the material Inconel 625, the elastic and plastic parts of the Universal Slopes method are isolated and life is determined for each part. This is done using constant strain values as well as with temperature

dependent strain. Figures 5 and 6 compare the elastic life prediction based on how the strain range is defined.

Both plots are subject to similar strain ranges, but in figure 5 the strain is held constant while the material properties are varied with temperature. From equation (5a) it is seen that life is function of material property ratios and the strain imposed. As a result, all the life ratio curves for the different strains used are identical since the ratio of material properties is identical for a given temperature in the elastic part of equation for constant strain. For figure 6, the life ratios are different since the strain values vary with temperatures, but the differences are not significant.

The most remarkable difference between the two figures is the overall behavior of the life ratio curve with decreasing temperature. In figure 5, the life benefit reaches a maximum around 1600 °R and then decreases even with decreasing temperature. It appears counterintuitive that life improves at a higher temperature as compared to a lower temperature. This apparent contradiction is better understood if the stress levels associated with these strain values are examined. Figures 7 and 8 show the stress levels corresponding to the strains in figures 5 and 6, that are normalized by the ultimate tensile strength of the material at the given temperature.

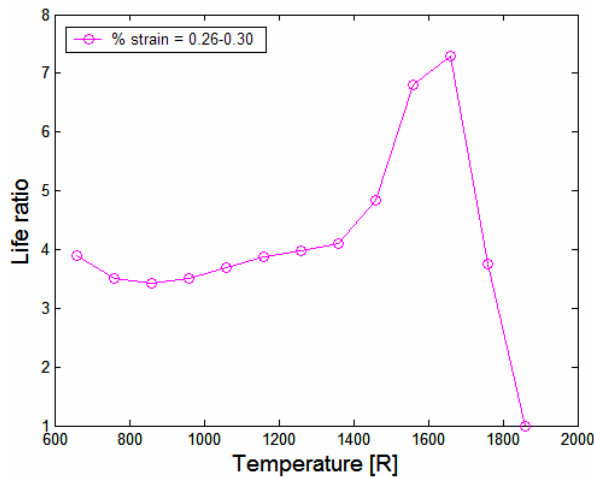

Figure 5.—Inconel 625, elastic life estimates with constant.

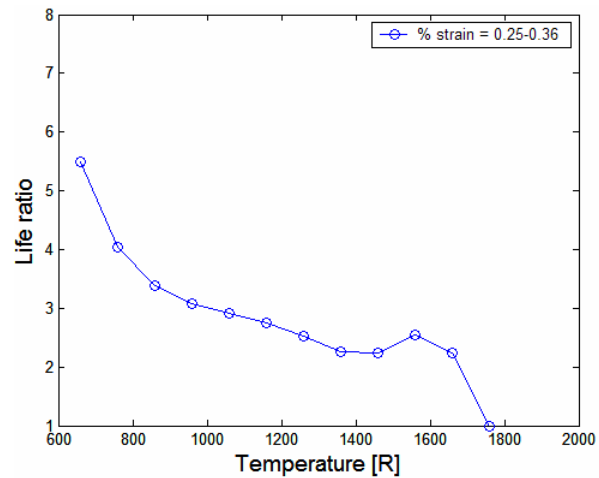

Figure 6.—Inconel 625, elastic life estimates with strain temperature dependent strain.

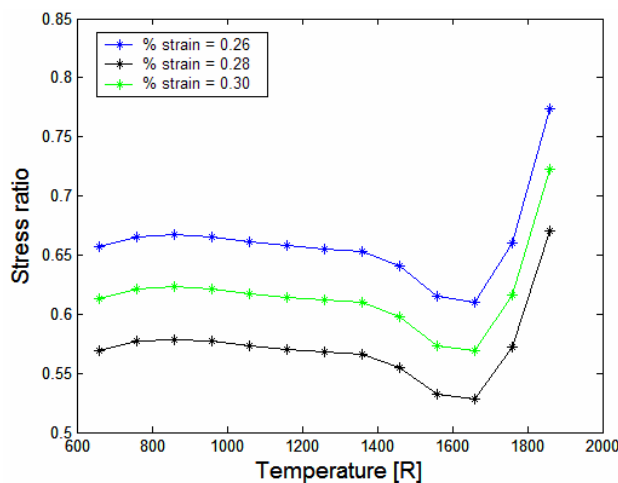

Figure 7.—Stress ratios for constrain strain, Inconel 625.

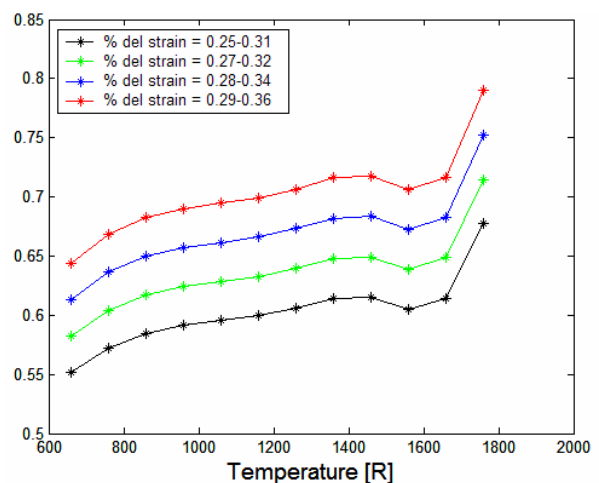

Figure 8.—Stress ratios for varying strain, Inconel 625.

It is seen that in the constant strain case, the stress ratio is almost constant at lower temperatures and drops around the 1600 °R temperature level by 0.02 or greater, this results in the life ratio peak in figure 5. There is also a drop in stress ratio in the case of varying strain level as shown in figure 8, but this drop is only about 0.01 and the stress levels increase over all with temperature. This drop in the stress ratio also results in a small peak in figure 6, but the overall trends are more reasonable than those of figure 5.

Summarizing elastic behavior, it can be said that stress and strain levels that increase with temperature more accurately describe the physical process expected. For a temperature change of 120 °R, the elastic life improves anywhere between a factor of 2 to 4.5 depending on the strain level and temperatures for Inconel 625.

Similarly, the plastic life was also determined over the same strain ranges using equation (5b) for Inconel 625. The results are displayed below in figures 9 and 10.

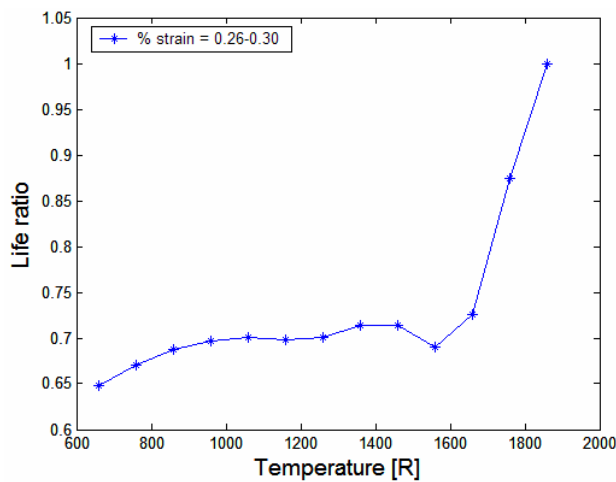

Figure 9.—Inconel 625, plastic life estimate with constant strain.

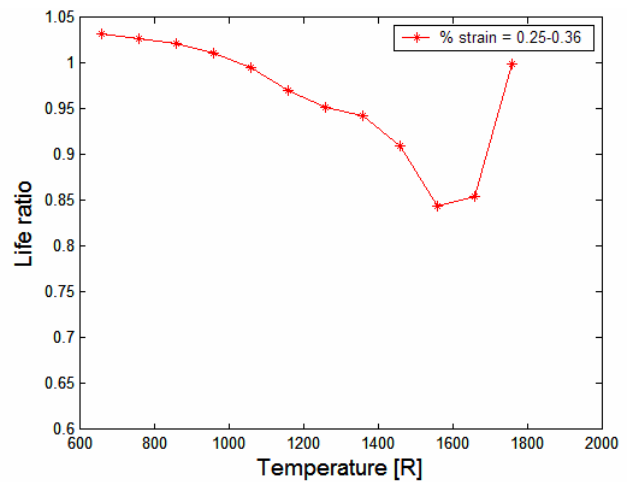

Figure 10.—Inconel 625, plastic life estimate with temperature dependent strain.

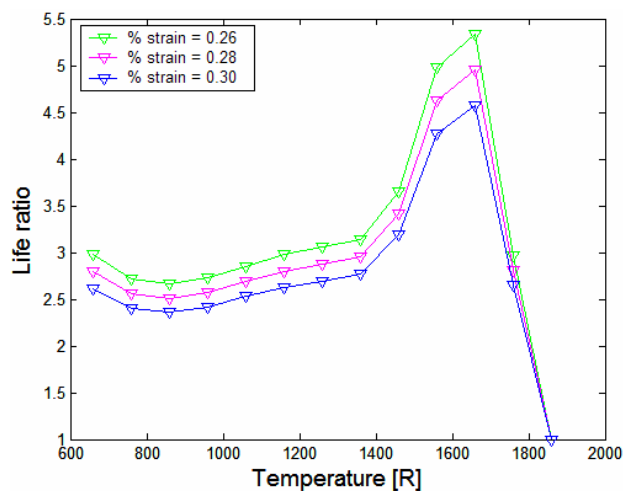

Figure 11.—Inconel 625, total life estimate with constant strain.

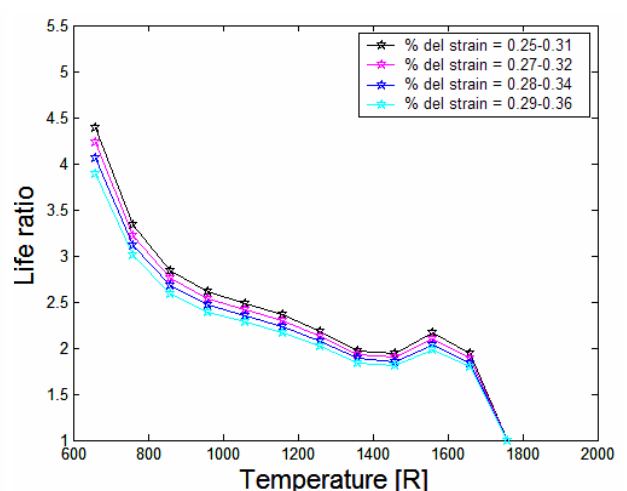

Figure 12.—Inconel 625, total life estimate with temperature dependent strain.

From equation (5b) it is seen that the plastic life is simply a function of ductility and strain values. Therefore, for constant strain, figure 9 almost resembles the ductility curve for Inconel 625 (fig. 5) and it is seen that there are no life benefits from decreasing temperature in the plastic life. However, with the strain values increasing with temperature, there is some life benefit seen at very low temperatures in figure 10, yet still no benefit at elevated temperatures albeit an improvement over constant strain..

The same analysis as above is repeated for the complete Universal Slopes method in equation (5), where the damped Newton-Rhapson method is used to solve equation (5) for N_f . The results are seen to strongly resemble the elastic life curves. It is observed the elastic life parameters dominate the total life of the component in terms of the trends noted.

Since it is expected that higher strain levels will result in lower life values and will alter the life ratio, different strain ranges are investigated. However, the curves follow the same trend and features from the elastic life curves are very dominant.

The impact of the plastic part of the equation is to reduce the actual values of the life ratios as can be seen in the following figures and comparing figure 5 and 6 with figures 11 and 12.

The total life benefits now range from a factor of 2 to 3.5 for a temperature reduction of 120 °R in the turbine inlet temperature, depending on the stress levels and temperatures used for Inconel 625.

4.1.2 Inconel 706 and Rene 80.—Total life estimates with temperature dependent strain are shown for Inconel 706 and Rene 80 in figures 13 and 14. The differences in life estimate behaviors of Inconel 706, Inconel 625 and Rene 80 primarily arise from variations in material properties.

The range of temperatures used for Inconel 706 is narrower than those used for the other materials, yet places little limitation on the comparisons for possible turbine applications. These figures can be compared with figure 12 for Inconel 625 to observe the effects of material type on the life estimates obtained from the Universal Slopes method. With a 120 °R reduction in turbine inlet temperature, life improves by a factor of approximately 1.65 for Inconel 706 and by a factor of about 3.5 for Rene 80 as seen from figures 13 and 14. In contrast, from figure 12 it is seen that fatigue life improves for Inconel 625 by a factor of 2 for the same turbine inlet temperature reduction.

It is thus clear from these comparisons, that an accurate estimate for life benefits can only be obtained with a detailed analysis using the exact materials, blade geometry, cooling and coatings, temperatures and load levels involved in the specified engine type. Life benefits will also be dependent on the statistical validity of the basis data sets used in the analysis.

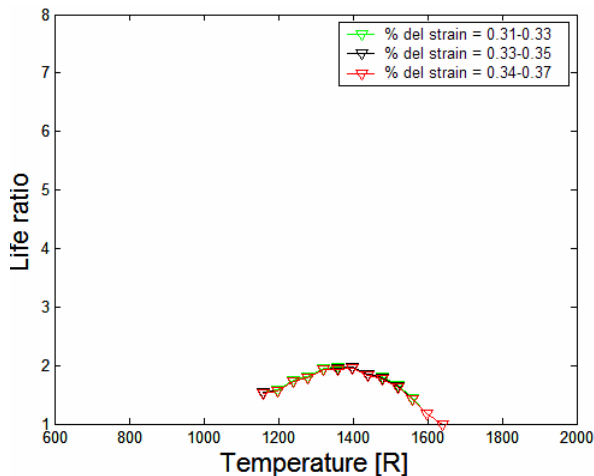

Figure 13.—Inconel 706, total life estimate with temperature dependent strain.

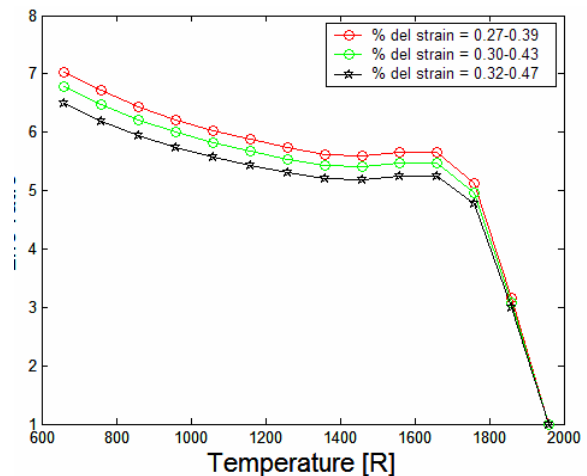

Figure 14.—Rene 80, total life estimate with temperature dependent strain.

4.1.3 Effect of ambient conditions.—There will also be differences in the fatigue life benefits possible based on ambient operating conditions. At higher ambient temperatures, T_4 levels can be expected to be higher than at cooler ambient temperatures. As seen from figures 12, 13 and 14 the slope of the fatigue life ratio curve changes depending on the temperature range concerned; at higher temperatures the life curve slope is steep as compared to lower temperatures where the life curve flattens out. This indicates that for the same 120 °F metal temperature reduction, it is possible for hot operators to encounter higher life benefits as compared to cold operators, with little or no benefits.

4.2 Creep and Oxidation Life Estimates

Owing to the complex interactions between fatigue, creep and oxidation, a detailed life estimate analysis that accounts for component failure due to the combined effects of all the three mechanisms is beyond the scope of this study. In order to provide a ballpark estimate for life benefits from water injection, some relevant results found through a literature search are included in this report. Based on common industry practice (ref. 10), approximations for changes in the first stage turbine blade life resulting from changes in gas and metal temperatures as well as centrifugal stresses are shown in table 1.

TABLE 1.—TURBINE BLADE LIFE ESTIMATE VARIATION WITH TEMPERATURE AND STRESSES (REF. 10)

Variation	1st Stage Blade Creep-Fatigue life	1st Stage Blade Oxidation life
Local gas temperature ± 18 °R (mean 3600 °R)	± 15%	± 14%
Metal temperature ± 5 °R (mean 1800 °R)	± 8%	± 8%
Centrifugal stresses ± 1%	± 6%	---

It can be noted from table 1 that blade life estimates are sensitive to the gas and metal temperature as well as stress levels used in the analysis. With large errors resulting simply from errors in temperature or stress levels used, there is a strong need to ensure that accurate data is used in performing such analyses. The combined effects of thermo-mechanical fatigue and creep are usually studied experimentally and then modeled based on the data obtained. The tests include varying thermal and mechanical loads simulating in-service working conditions. In a study by S.X. Li and D.J. Smith (ref. 9) the effects of temperature and cyclic loading were investigated on a single crystal nickel base superalloy, SRR99. The tests are carried out at 750 °C (1842 °R) and 1050 °C (2382 °R). The specimens were exposed to three different loading conditions, continuous cycling (denoted as 0/0), cycling with a tensile dwell, (t/0) and with a compressive dwell, (0/t). The tensile and compressive dwells were imposed to study crack initiation and propagation under combined fatigue and creep loading; the dwells were at constant strain for 2 minutes.

The results for crack initiation life and propagation rates are shown in figures 15 and 16 for both temperatures tested. Assuming tensile strains are more dominant in the case of turbine blades, from figure 15 it can be noted that under tensile strain dwells, crack initiation life decreases as testing temperature increases. For approximately similar normalized strain levels, the crack initiation life changes from about 3000 to 5000 cycles for 750 °C (1842 °R) to around 200 to 400 cycles for 1050 °C (2382 °R). Similarly, crack propagation rates increase with increasing temperature for tensile strain dwells as noted in figure 16. Notably, the total strain range imposed at higher temperatures is less than that used at lower temperatures in order to observe the crack propagation behavior prior to complete failure. For 750 °C (1842 °R), propagation rates are about 0.0005 to 0.001 mm/cycle; they increase by an order of magnitude to 0.0025 – 0.004 mm/cycle at 1050 °C (2382 °R). In figures 15 and 16, the triangles correspond to tensile strain dwells.

Thus, under tensile strain loads, the results of this study demonstrate that for alloy SRR99 crack initiation life decreases and crack propagation rates increase by an order of magnitude when the testing temperature is increased from 750 °C (1842 °R) to 1050 °C (2382 °R). Along with temperature and mechanical load effects, properties of the base alloys and coating materials involved are also deciding factors in the interactions between the different failure mechanisms. The protective coatings or the thermal barrier coatings (TBCs) impact the mechanical properties of the base alloy as well. The protective coatings are designed to shield the base material from environmental attacks and the TBCs reduce the effective temperature seen by the alloy. Due to the difference in material properties between the coatings and base materials, such as coefficients of thermal expansion, tensile and compressive stresses are imposed on the coatings. Creep and cyclic loading result in cracking and spalling of the coatings exposing the alloys to higher temperatures and corrosive environments. Environmental effects can be incorporated into the crack propagation models for the coatings and can be experimentally validated.

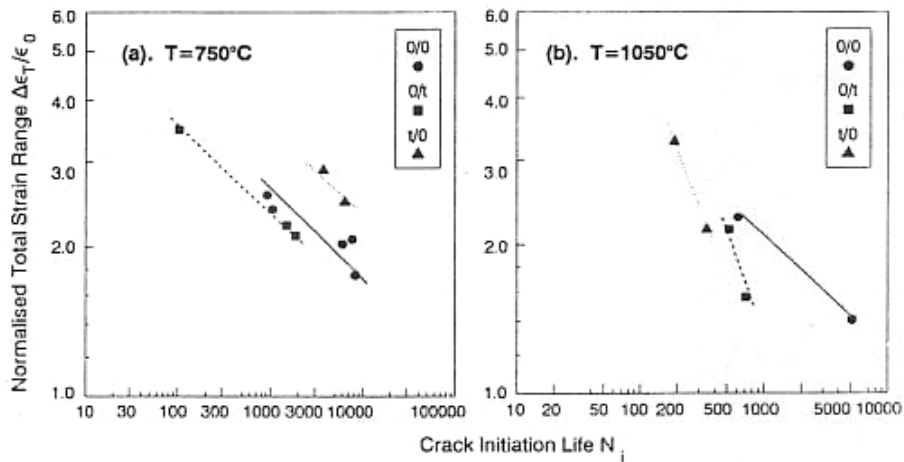

Figure 15.—Influence of strain dwells and temperature on crack initiation life for SRR99 (ref. 9).

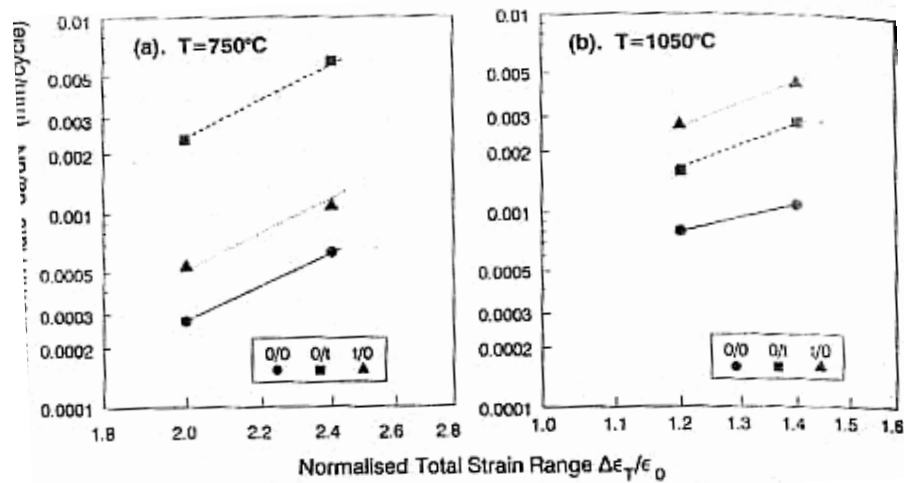

Figure 16.—Influence of strain dwells and temperature on crack propagation for SRR99 (ref. 9).

It can be seen that this analysis is strongly dependent on the material properties and temperature and stress-strain ranges. Using Inconel 625 as a representative material, the fatigue life benefits range anywhere from a factor of 2 to 4.5 for a 120 °R change in turbine inlet temperature, depending on the details of the parameters applied. Owing to the lack of detailed knowledge of the blade geometry, loads, operating temperatures and temperature gradients, the level of this analysis are confined to a generic approach to predict overall trends in life. Consequently, the Universal Slopes method is used, which was developed from average values of material constants from experimental data available. In addition to the limitations arising from the lack of detailed data, there are also some notable shortcomings in the application of the Universal Slopes method. The coefficients used in equation (5) are obtained through isothermal, room temperature fatigue tests done on a wide range of materials. As shown in the Manson report (ref. 4), these average coefficients provide fairly reliable life estimates for the 29 materials tested with 99.5 percent of the experimental data falling within a factor of 20 of the predicted life. However, life estimates obtained under thermo-mechanical fatigue (TMF) can vary significantly from those obtained from isothermal low cycle fatigue. Under in-service conditions, turbine blades are exposed to widely varying thermo-mechanical loads and simplified isothermal models do not capture the complexity of the situation. The deviation of isothermal results from TMF results depends largely on the material properties and the nature of the TMF cycle. The primary reason for the use of the Universal Slopes method in this analysis was the ease involved in its use and availability of the necessary material data. Regardless of the limitations involved, this method is an appropriate tool for a preliminary design level analysis where the overall trends in life behavior are sought.

In order to enhance the accuracy of the method, these material constants would have to be determined experimentally for the material in question. Other methods that predict life more accurately can also be used if more data are available that also account for the interactions between the different failure mechanisms, namely creep, oxidation and fatigue. Effects of creep can be incorporated into the crack propagation analysis mentioned previously. It is difficult to capture the effects of oxidation in a generic study like this since details about the nature of the protective coatings and their impacts on the base alloy are complex phenomena. Despite the shortcomings of the methods applied in this study, it can be said with confidence that improvement in turbine blade life is expected. The exact range of possible life extension depends on the details of the parameters involved.

4.3 Material Maintenance Cost Benefits

Maintenance cost data was obtained from an airline for a typical 1970's technology engine showing effects of de-rated operations and flight duration. In order to extract maintenance cost estimates for water injection from this data, T_4 reductions from de-rated operations had to be related to changes in T_4 resulting from water injection. This was accomplished by plotting full throttle curves for several cycles for a single, typical 1970's technology mixed flow turbofan engine as shown in figures 17 through 21.

Figures 17 through 21 show several different engine cycles analyzed through GasTurb (ref. 2) by varying critical parameters such as the OPR, BPR, T_4 , component polytropic efficiencies and the mass flow. Thus, the relationship between thrust and turbine inlet temperature is established and based on this first order analysis it is seen that the throttle curves are not very sensitive to changes in most of the key parameters. Table 2 shows the average, maximum and minimum values of the slope of the linear fits to the cycle deck data. From equation (7) it is seen that these slopes relate the ratios of change in the net thrust to change in T_4 with units of [kN/K]. Also indicated in table 2 are the percent de-rate values corresponding to the average, minimum and maximum values of the slope for a change in T_4 of 120 °R from water injection.

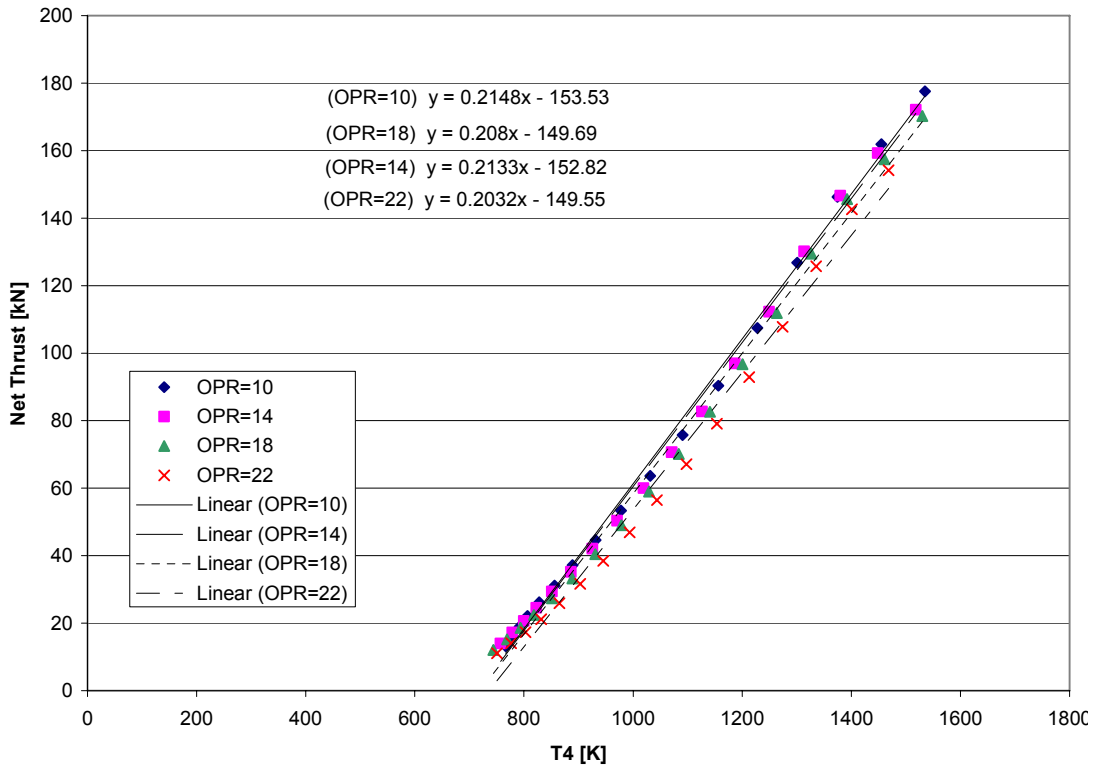

Figure 17.—Net thrust vs. T_4 for varying OPR, spool speeds 0.75 to 1.15, design point: BPR = 4.5, $m = 500$ kg/s, $T_4 = 1200$ K, polytropic efficiency = 0.9.

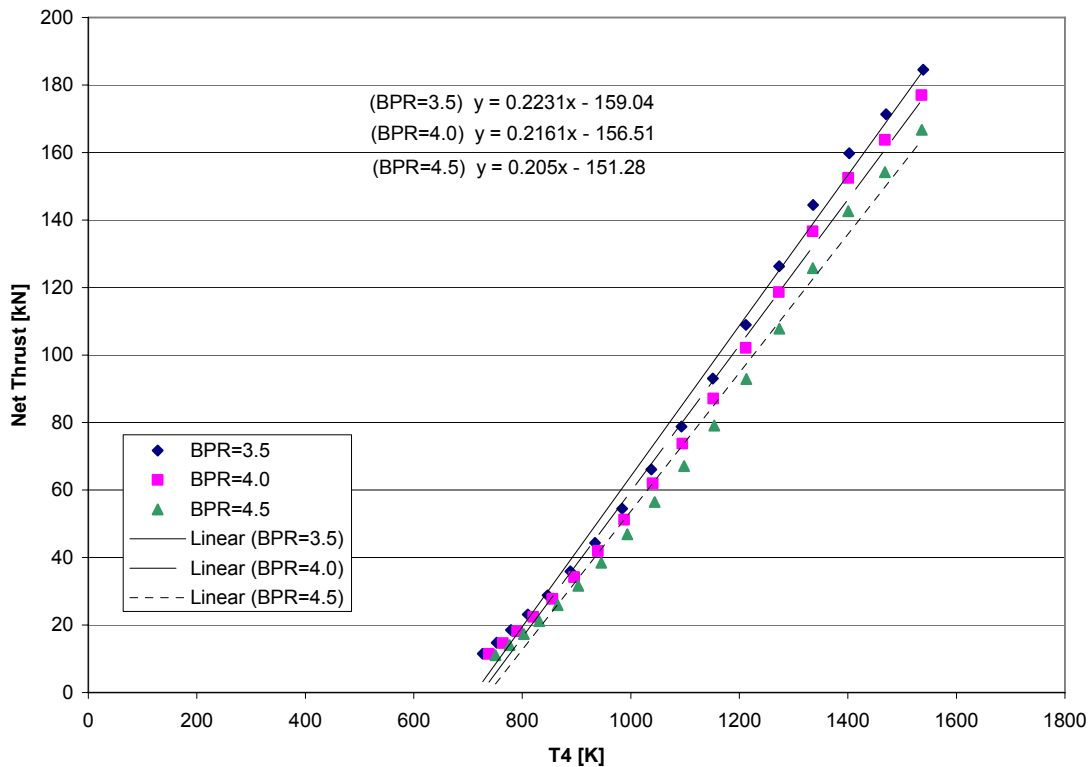

Figure 18.—Net thrust vs. T_4 for varying BPR, spool speeds 0.75 to 1.15, design point: OPR = 22, $m = 500$ kg/s, $T_4 = 1200$ K, polytropic efficiency = 0.9.

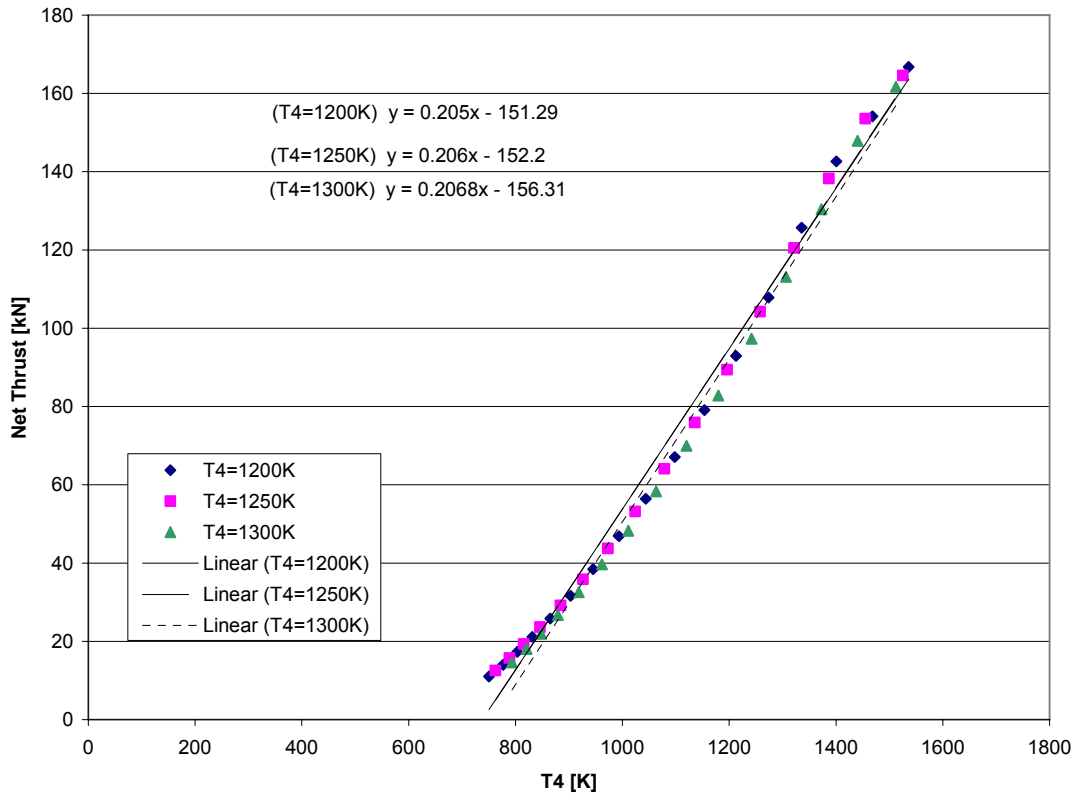

Figure 19.—Net thrust vs. T_4 for varying T_4 , spool speeds 0.75 to 1.15, design point: OPR = 22, $m = 500$ kg/s, BPR = 4.5, polytropic efficiency = 0.9.

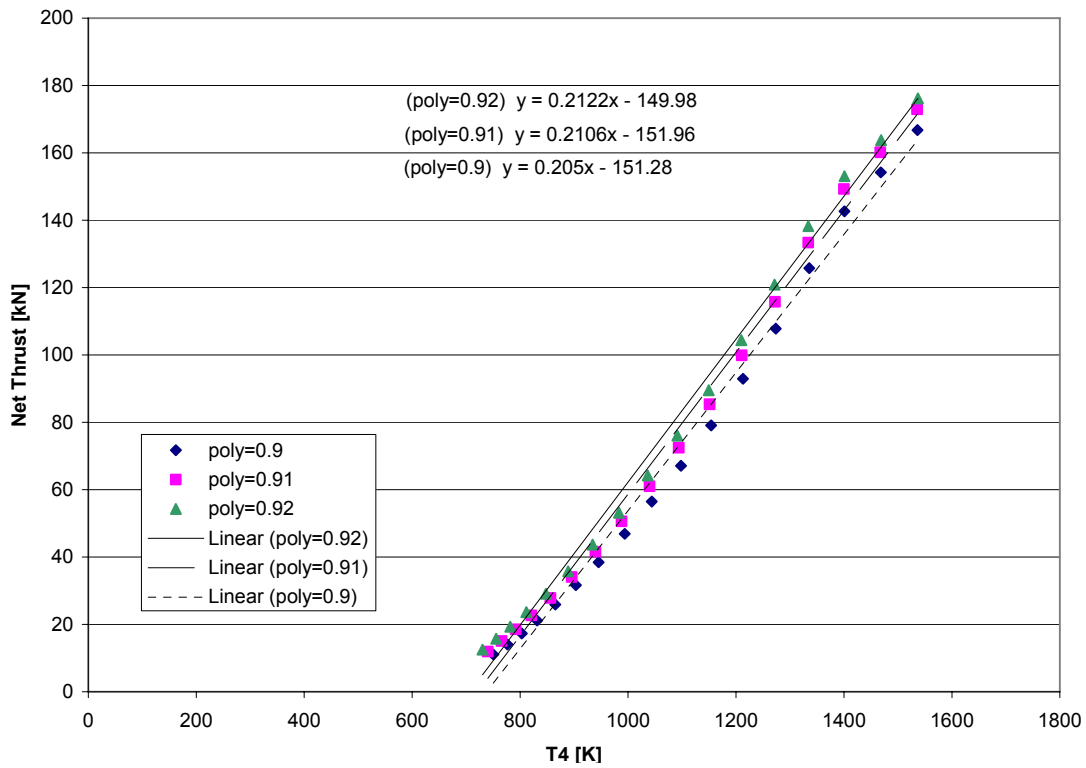

Figure 20.—Net thrust vs. T_4 for varying polytropic efficiency, spool speeds 0.75 to 1.15, design point: BPR = 4.5, $m = 500$ kg/s, $T_4 = 1200$ K, OPR = 22.

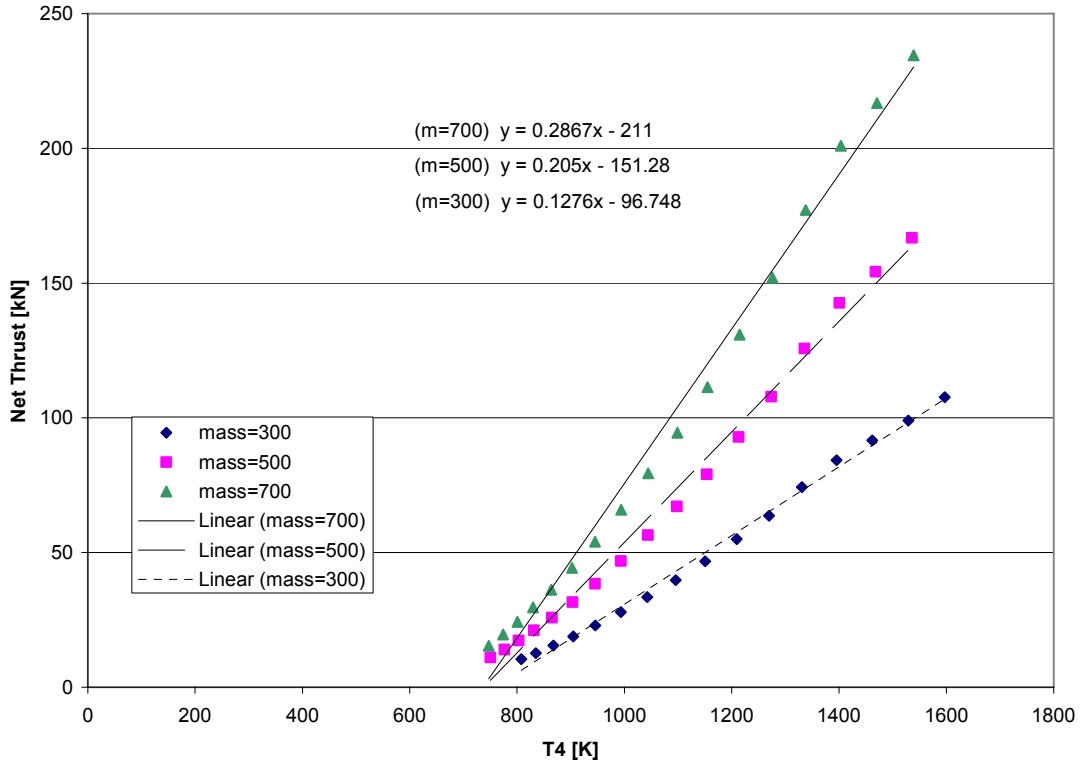

Figure 21.—Net thrust vs. T_4 for varying mass flow, spool speeds 0.75 to 1.15, design point: BPR = 4.5, OPR = 22, $T_4 = 1200$ K, polytropic efficiency = 0.9

TABLE 2.—AVERAGE, MINIMUM AND MAXIMUM VALUES OF THE THRUST DE-RATE FROM WATER INJECTION

	Slope [kN/K]	% De-rate
MIN	0.13	5.1
AVG	0.21	8.4
MAX	0.29	11.5

It is seen that depending on the engine cycle data used, the percent de-rate value corresponding to water injection can range from 5.1 to 11.5 percent. The cost benefits resulting from the equivalent water injection thrust de-rate are calculated based on the airline maintenance material cost data mentioned previously. This data includes maintenance material costs per engine flight hour for basic causes as well as FOD but does not cover the associated labor costs. Only the effects of takeoff de-rate caused by water injection are evaluated in this analysis. Table 3 shows the percent reduction material maintenance costs per engine flight hour (MMC/EFH) in 2004 dollars for three different flight lengths as well as for the different takeoff de-rate values discussed previously. It is seen that costs decrease with increasing flight time which is expected since longer flight times indicate that a small portion of the flight is spent at critical takeoff level temperatures. Costs also decrease with increasing de-rate levels, since this reduces effective operating temperature.

TABLE 3.—PERCENT REDUCTION IN MMC/EFH IN 2004 DOLLARS
FOR A RANGE OF TAKEOFF DE-RATES AND FLIGHT LENGTHS

T.O. de-rate (%)	1 hour % change	6 hour % change	12 hour % change
5	10.43	6.06	1.90
8.4	16.52	9.09	2.86
11.5	20.87	10.61	3.81

Thus, it can be seen that maintenance material cost benefits are possible from a T_4 reduction of 120 °R (66.67 K) from water injection. The actual benefits possible depend on the flight length and values of de-rate corresponding to the T_4 reduction obtained from the engine cycle deck. It is important to note that this analysis only represents a single engine. However, the results are significant in that for this engine a narrow range of possible reductions in cost can be presented with confidence. Clearly, this method of assessing costs relies primarily on data available from industry. A greater level of confidence can be placed in the results if the engine in question can be simulated in a more advanced cycle deck than GasTurb (ref. 2). Since the throttle curves didn't show much variation with changes in cycle parameters, this study provides a good preliminary estimate of cost benefits from water injection.

5. Future Work and Conclusions

The results presented in this study have only addressed the effects of varying loads and temperatures on the turbine fatigue life in some detail. The Universal Slopes method was used to obtain life estimates without any specific or detailed information about the component or operating conditions. This enabled the results of the study to be broad and generic, not limited to any particular type of engine or load cycle. The life estimate methodology was primarily from a materials point of view since detailed component information was not available for the analysis. The sensitivity of the results obtained to both strain values and material properties used was tested and it was found that life in general does not continuously decrease with increasing temperature. For Inconel 625, life improvements ranging from a factor of 2 to 4.5 can be expected for a 120 °R change in turbine inlet temperature, depending on the stress-strain levels and temperatures. Similarly, life improves by a factor of approximately 1.65 for Inconel 706 and by a factor of about 3.5 for Rene 80 under thermally varying strains with the same turbine inlet temperature reduction. Effects of creep and oxidation on blade life are presented in brief based on a literature search. Life estimates can show large variations due to changes in temperatures and stresses. It is seen that for alloy SRR99, crack initiation life decreases and crack propagation rates increase by an order of magnitude for a temperature increase of 300 °C (540 °R). Given additional detailed data on load conditions and operating temperatures, other methodologies that provide a more accurate analysis can be employed.

Based on airline data and engine cycle deck analyses, the results from this study show that water injection may yield maintenance cost benefits similar to those achieved from de-rated operations. Both water injection and de-rated operations result in lowered engine temperatures, effectively extending part life and reducing material maintenance costs. This analysis was carried out for a specific 1970's technology mixed flow turbofan engine owing to the availability of airline data. From results of this study, it is seen that cost benefits increase with decreasing flight duration. Higher de-rate levels corresponding to greater reductions in operating temperatures also yield increase benefits. Enhanced fidelity engine and flight cycle-deck analysis along with more detailed costing benefits may be warranted, yet will be more demanding of statistically significant operational data.

Acknowledgements

The author would like to thank Professor Mark Spearing and Dr. Philippa Reed from the University of Southampton, UK, for their help and guidance in the turbine life section.

References

1. Lee J.J., *Modeling Aviation's Global Emissions, Uncertainty Analysis, and Applications to Policy*, PhD Thesis, Massachusetts Institute of Technology, February 2005.
2. Kurzke, J., "GasTurb 9," www.gasturb.de
3. Suresh, S., *Fatigue of materials*. 2nd ed. 1998: Cambridge University Press, MA.
4. Manson, S.S., "Fatigue: A Complex Subject – Some Simple Approximations," The William M. Murray Lecture, 1964, Presented at 1964 SESA Meeting, Cleveland, OH, 28–30 October.
5. High Temp Metals Inc., Technical library, <<http://www.hightempmetals.com/technicaldata.php>>
6. Military Handbook—MIL-HDBK-5H: Metallic Materials and Elements for Aerospace Vehicle Structures, 2003 U.S. Department of Defense.
7. Klopp, W.D., Nonferrous alloys, Aerospace Structural Metals Handbook, Code 4214, pp. 1–18, Sept. 1984.
8. Personal communication with an airline.
9. Li, S.X., and Smith, D.J., "High Temperature fatigue-creep crack initiation and propagation of a single crystal nickel base superalloy," IMechE Conference Transactions: Creep and Fatigue, pp. 279–288, April 1996.
10. Zupnik, T.F., "Hot Section Technology", Pratt Whitney, GTL Lecture Series-MIT, 1979.

Appendix B—Acronyms and Abbreviations

BCA	Boeing Commercial Airplane
BPR	bypass ratio
CAEP	Committee on Aviation Environmental Protection (ICAO)
CAROC	cash airplane related operating cost
CET	combustor exit temperature
CO	carbon monoxide
CRES	corrosion resistant steel
ECS	Environmental Control System
EGT	exhaust gas temperature
EINO _x	emissions index for NO _x given as grams of NO _x /kg fuel
FADEC	full authority digital engine control
FAR	Federal Aviation Regulation (U.S.A.)
FDV	fuel distributor valve
FMV	fuel management unit
HC	hydrocarbons
HPC	high-pressure compressor
ICAO	International Civil Aviation Organization
IDG	integrated drive generator
load factor	percentage of an airplane's seat capacity occupied by passengers
LAX	Los Angeles International Airport
LTO	landing-takeoff cycle
LPC	low-pressure compressor
MAVEL	mass-averaged jet velocity
MTOW	maximum takeoff weight
N1	first engine spool
N2	second engine spool
NASA	National Aeronautics and Space Administration (U.S.A.)
NEPP	Numeric Engine Performance Program
NO _x	nitrogen oxides
NPV	net present value
OD	outer diameter
OEM	original equipment manufacturer
OPR	overall pressure ratio
OEW	operating empty weight
RA	area reduction
RO	reverse osmosis
SLS	Sea Level Static
std	standard
SFC	specific fuel consumption (lb fuel per hour and lb thrust or power)
SOW	statement of work
T3	temperature at the exit of the HPC
T4	temperature at the inlet to the high-pressure turbine (TIT)
TAROC	total airplane-related operating cost
TIT	turbine inlet temperature
TMF	thermomechanical fatigue
TOGW	takeoff gross weight
TRL	technology readiness level
TVC	trapped vortex combustor

Appendix C—Trade Study Scope Sheet

1. Trade Study No.: NNC04QB58P	2. Study Title: Water injection for Boeing 747 aircraft										
3. Date Assigned: Sept. 2004	4. Responsible IPT: Airplane Environmental Performance										
5. Date Due: April 28, 2005	6. Performing Engineer: Dave Daggett										
7. AIT/IPT Approval: Billy Glover, Dave Anderson, Andy Cox											
<p>8. Background/ issue:</p> <p>Airports are facing increased environmental pressure to reduce airplane gaseous emissions. New low NO_x combustors only offset increased NO_x that comes with high efficiency (i.e., high pressure ratio) engines.</p>											
<p>9. Purpose:</p> <p>Find a way to cut airplane takeoff NO_x >50 percent with minimal cost to the operator</p>											
<p>10. Scope, Groundrules and Assumptions</p> <p>Determine if water injection system studies should be further pursued in more depth.</p>											
<p>11. Areas to be addressed (identify as appropriate)</p> <table style="width: 100%; border: none;"> <tr> <td style="width: 50%;"><input checked="" type="checkbox"/> Performance</td> <td style="width: 50%;"><input checked="" type="checkbox"/> Growth</td> </tr> <tr> <td><input checked="" type="checkbox"/> Technical/schedule risk</td> <td><input type="checkbox"/> Operational Flexibility</td> </tr> <tr> <td><input checked="" type="checkbox"/> Cost</td> <td><input type="checkbox"/> Safety</td> </tr> <tr> <td><input checked="" type="checkbox"/> Reliability</td> <td><input checked="" type="checkbox"/> Logistics</td> </tr> <tr> <td><input checked="" type="checkbox"/> Maintainability</td> <td><input type="checkbox"/> Producibility</td> </tr> </table>		<input checked="" type="checkbox"/> Performance	<input checked="" type="checkbox"/> Growth	<input checked="" type="checkbox"/> Technical/schedule risk	<input type="checkbox"/> Operational Flexibility	<input checked="" type="checkbox"/> Cost	<input type="checkbox"/> Safety	<input checked="" type="checkbox"/> Reliability	<input checked="" type="checkbox"/> Logistics	<input checked="" type="checkbox"/> Maintainability	<input type="checkbox"/> Producibility
<input checked="" type="checkbox"/> Performance	<input checked="" type="checkbox"/> Growth										
<input checked="" type="checkbox"/> Technical/schedule risk	<input type="checkbox"/> Operational Flexibility										
<input checked="" type="checkbox"/> Cost	<input type="checkbox"/> Safety										
<input checked="" type="checkbox"/> Reliability	<input checked="" type="checkbox"/> Logistics										
<input checked="" type="checkbox"/> Maintainability	<input type="checkbox"/> Producibility										
<p>12. Items expected to be impacted (e.g. baseline design, system requirements, specifications, etc.):</p> <p>Engine and Airframe baseline designs. Procurement of additional equipment. Airplane engine performance</p>											
<p>13. Figure(s) of merit / key discriminator(s):</p> <p>Improved Life Cycle Cost and Airplane Environmental Performance</p>											
<p>14. Output Required:</p> <ul style="list-style-type: none"> - Level 0 Preliminary Designs. - Recommended system concept. - Documentation of study. 											

REPORT DOCUMENTATION PAGE

Form Approved
OMB No. 0704-0188

Public reporting burden for this collection of information is estimated to average 1 hour per response, including the time for reviewing instructions, searching existing data sources, gathering and maintaining the data needed, and completing and reviewing the collection of information. Send comments regarding this burden estimate or any other aspect of this collection of information, including suggestions for reducing this burden, to Washington Headquarters Services, Directorate for Information Operations and Reports, 1215 Jefferson Davis Highway, Suite 1204, Arlington, VA 22202-4302, and to the Office of Management and Budget, Paperwork Reduction Project (0704-0188), Washington, DC 20503.

1. AGENCY USE ONLY (<i>Leave blank</i>)	2. REPORT DATE December 2005	3. REPORT TYPE AND DATES COVERED Final Contractor Report	
4. TITLE AND SUBTITLE Water Injection Feasibility for Boeing 747 Aircraft		5. FUNDING NUMBERS Cost Center 2250000013 NNC0466315Q	
6. AUTHOR(S) David L. Daggett		8. PERFORMING ORGANIZATION REPORT NUMBER E-15146	
7. PERFORMING ORGANIZATION NAME(S) AND ADDRESS(ES) Boeing Commercial Airplane Group P.O. Box 3707 Seattle, Washington 98124-2207		10. SPONSORING/MONITORING AGENCY REPORT NUMBER NASA CR-2005-213656	
9. SPONSORING/MONITORING AGENCY NAME(S) AND ADDRESS(ES) National Aeronautics and Space Administration Washington, DC 20546-0001		11. SUPPLEMENTARY NOTES Project Manager, Robert C. Hendricks, Research and Technology Directorate, NASA Glenn Research Center, organization code R, 216-977-7507.	
12a. DISTRIBUTION/AVAILABILITY STATEMENT Unclassified - Unlimited Subject Categories: 07, 26, 27, 37, and 45 Available electronically at http://gltrs.grc.nasa.gov This publication is available from the NASA Center for AeroSpace Information, 301-621-0390.		12b. DISTRIBUTION CODE	
13. ABSTRACT (<i>Maximum 200 words</i>) Boeing 747-400 airplane performance impact of using water injection is presented. Using a 1:1 water-to-fuel ratio, NO _x is reduced 80 percent during takeoff and turbine inlet temperature would be reduced 120 °F (67 K), which may improve life 29 percent for a PW4062 engine. Performance penalties include a 750 lb weight increase, 1.2 percent high-pressure compressor surge margin deterioration and loss of range and payload. For a newly designed airplane, the potential engine maintenance savings may offset penalties to save an operator up to 1 percent in operating costs. For existing aircraft, high development and testing and certification costs would make retrofit kits cost prohibitive.			
14. SUBJECT TERMS Aircraft; Economics; Engines; Emissions; Water injection			15. NUMBER OF PAGES 106
			16. PRICE CODE
17. SECURITY CLASSIFICATION OF REPORT Unclassified	18. SECURITY CLASSIFICATION OF THIS PAGE Unclassified	19. SECURITY CLASSIFICATION OF ABSTRACT Unclassified	20. LIMITATION OF ABSTRACT

