

# Development of a Coherent Lidar for Aiding Precision Soft Landing on Planetary Bodies

Farzin Amzajerdian<sup>1</sup>, Diego Pierrottet<sup>2</sup>, Robert H. Tolson<sup>3</sup>, Richard W. Powell<sup>1</sup>,  
John B. Davidson<sup>1</sup>, and Frank Peri<sup>1</sup>

<sup>1</sup>NASA Langley Research Center, MS 468, Hampton, Virginia 23681, USA

<sup>2</sup>Coherent Applications, Inc., Hampton, Virginia

<sup>3</sup>National Institute of Aerospace, Hampton, Virginia

## INTRODUCTION

Coherent lidar can play a critical role in future planetary exploration missions by providing key guidance, navigation, and control (GNC) data necessary for navigating planetary landers to the pre-selected site and achieving autonomous safe soft-landing. Although the landing accuracy has steadily improved over time to approximately 35 km for the recent Mars Exploration Rovers due to better approach navigation, a drastically different guidance, navigation and control concept is required to meet future mission requirements<sup>1,2</sup>. For example, future rovers will require better than 6 km landing accuracy for Mars and better than 1 km for the Moon plus maneuvering capability to avoid hazardous terrain features. For this purpose, an all-fiber coherent lidar is being developed to address the call for advancement of entry, descent, and landing technologies. This lidar will be capable of providing precision range to the ground and approach velocity data, and in the case of landing on Mars, it will also measure the atmospheric wind and density. The lidar obtains high resolution range information from a frequency modulated-continuous wave (FM-CW) laser beam whose instantaneous frequency varies linearly with time<sup>3-5</sup>, and the ground vector velocity is directly extracted from the Doppler frequency shift. Utilizing the high concentration of aerosols in the Mars atmosphere (~ two order of magnitude higher than the Earth), the lidar can measure wind velocity with a few watts of optical power. Operating in 1.57 micron wavelength regime, the lidar can use the differential absorption (DIAL) technique to measure the average CO<sub>2</sub> concentration along the laser beam using, that is directly proportional to the Martian atmospheric density. Employing fiber optics components allows for the lidar multi-functional operation while facilitating a highly efficient, compact and reliable design suitable for integration into a spacecraft with limited mass, size, and power resources.

## LIDAR GUIDANCE, NAVIGATION, AND CONTROL SYSTEM

The Coherent lidar can assist the precision safe landing on planetary bodies both without atmosphere and with atmosphere. For landing on bodies with atmosphere, in particular Mars, the lidar can provide wind velocity and atmospheric density data in addition to the range and velocity measurements.

### 1. Lidar GNC System for Landing on Bodies Without Atmosphere

Precision range and velocity data provided by the lidar allows for updating the position and attitude data from the Inertial Measurement Unit (IMU) needed for accurately navigating the spacecraft to the desired landing location. The lidar data can be used to compensate for the IMU uncertainties due to drift and accumulated errors during the long space travel and the uncertainties in the vehicle aerodynamic characteristics after entry. In addition, both vertical and lateral vector velocities are critical for the GNC algorithm for adequately controlling the vehicle during the powered descent and landing phase to a safe soft-landing avoiding the identified hazardous rocks and slopes. For example, the Mars Science Laboratory has a requirement that the spacecraft must touchdown with a horizontal velocity of less than 0.5 m/s and a vertical velocity less than 1 m/s. To control to these limits will require measurement accuracies to better than 10 cm/sec for horizontal component and 30 cm/sec for vertical component. The coherent lidar, being described in this paper, can easily meet these requirements.

Another area that the FM-CW coherent lidar can play a critical role is the identification of hazardous terrain features and terrain-aided navigation. Hazard avoidance and terrain-aided navigation utilizing a 3-D imaging

lidar (ladar) has been extensively investigated in the past<sup>1,6</sup> indicating major challenges in generating elevation maps of the targeted area with sufficient resolution and coverage. The field of view and resolution of 3-D imaging lidars for a given frame rate are mainly limited by their transmitted power which in turn is constrained by the vehicle's limited available power. One solution is to use the vehicle's motion during its initial descent to collect a number of segmented maps of different parts of the terrain that can together form a sufficiently large map of the targeted landing area. However at this stage, the landing vehicle will be descending with a high velocity (>100 m/sec) and highly accurate range and velocity data with a relatively high update rate (> 50Hz) is required to scale the individual frames and construct an elevation map. The FM-CW coherent lidar, using pointing angle data from the onboard IMU, can provide the necessary lander's range to the ground and its lateral and vertical velocities for constructing an elevation map of the landing area. This map can be then processed to identify hazardous rocks and steep slopes, specify their location in reference coordinate system, determine the optimum landing site, and to perform terrain-aided navigation to touch down. Figure 1 illustrates the operation of a GNC system using the data provided by the coherent lidar and a 3-D imaging lidar.

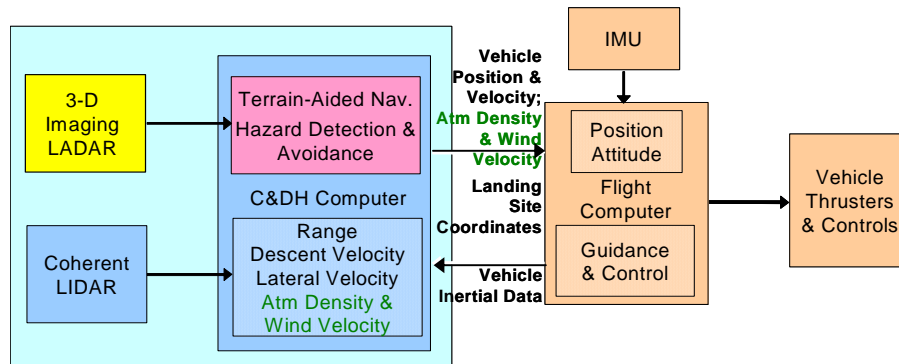

Figure 1. Functional diagram of lidar-based GNC system.

## 2. Lidar GNC System for Landing on Bodies With Atmosphere

Knowledge of atmospheric winds and density during the initial descent phase can greatly reduce the uncertainties affecting precision landing on the surface of Mars. The Mars low-level winds are considered the major source of error in delivering the spacecraft to the desired landing site. The ability of coherent lidar in measuring atmospheric winds will mitigate this source of uncertainty and allows for precision landing with a reasonable lander maneuverability range of the order of 100 meters. The alternative would be to increase the maneuverability range to several kilometers which will drastically increase the mission cost and risk due to extra propellant and its associated reservoir and plumbing. Operating in differential absorption mode (DIAL), the lidar can also measure the average CO<sub>2</sub> concentration along the laser beam<sup>7</sup> that is directly proportional to the Martian atmospheric density (Mars atmosphere is 95% CO<sub>2</sub>). The combined wind velocity and atmospheric data can be used for adjusting the timing of the lander parachute deployment in order to better control of flight trajectory and further reducing the required maneuverability range. In addition, the atmospheric density data will be important for post flight analysis and design of follow on missions to Mars and other planetary bodies.

### LIDAR SENSOR DESCRIPTION

The lidar obtains high resolution range information by transmitting a linearly frequency modulated waveform. As shown in Figure 2, the transmitted waveform will be delayed by  $t_a$ , the light round trip time, upon reflection from the surface. When mixing the delayed return waveform with the transmitted waveform at the detector, an interference signal will be generated whose frequency is equal to the difference between the transmit and receive frequencies. This frequency is directly proportional to the target range. When the target or the Lidar platform is not stationary during the beam round trip time, the signal frequency will be also shifted due to the Doppler effect. Therefore by measuring the frequency during “up chirp” and “down chirp” periods of the laser waveform, both the target range and velocity can be determined.

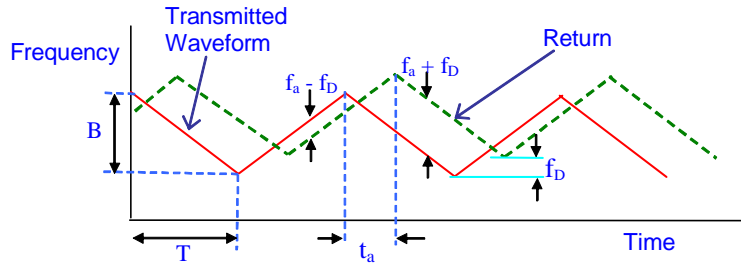

Figure 2 - Transmit and return frequency chirp waveforms.

The frequency modulated-continuous wave (FM-CW) technique was first demonstrated by using radio wave transmitters<sup>3</sup> showing more than an order of magnitude improvement in measurement accuracy over simple “pulse time of arrival” method. The use of lasers was the next logical step offering much smaller footprint and higher frequency<sup>4</sup> that can translate to an order of magnitude improvement over radars. However, earlier FM-CW coherent lidars suffered from the laser technology limitations in generating narrow linewidth beam and ability in producing linear frequency modulation waveforms<sup>5</sup>. But, recent advances in photonic technologies mainly due to substantial investment by the telecommunication industry have now created new opportunities for developing FM-CW coherent lidars capable of producing high precision range and velocity data and that are compact, rugged, and efficient meeting the stringent requirements of planetary exploration missions.

The design of the breadboard lidar developed for this work is described in Figure 3. A low power semiconductor InGaAs laser operating in the eye-safe region of the near infrared spectrum at 1.57 microns is used as the seed source. The seed laser uses an external cavity Bragg grating to generate a very narrow linewidth and stable output of a few milliwatts. The seed laser generates the required frequency modulation waveform by controlling its cavity length using a PZT actuator. Part of the laser beam is split for use as the local oscillator for optical heterodyne detection. The remaining part of the diode laser output is amplified by a single mode Erbium-doped fiber amplifier to increase its power to several watts. The fiber amplifier output is expanded and transmitted by a lens. The reflected laser radiation is collected by the same lens and focused into an optical fiber. A transmit/receive switch directs the returned radiation to a detector where it is mixed with the local oscillator beam.

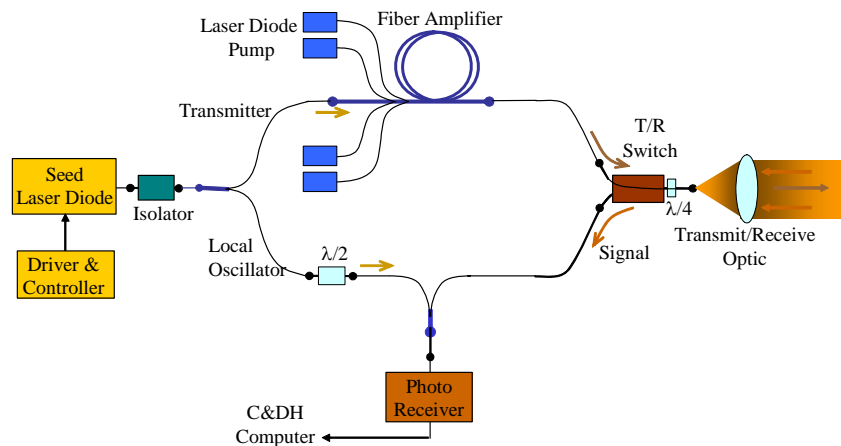

Figure 3 - All-fiber Coherent Doppler Lidar Sensor Schematic.

Initial measurements were performed using a sandpaper, located about 250 meters from the lidar, to simulate a diffuse target. Figure 4 shows two spectrograms of the received signals. The top spectrogram is of the signal from the target in stationary position and the lower spectrogram shows the signal with belt sander running simulating a moving target. For the stationary target, the range is directly related to the peak frequency of the signal spectrum. When the target is moving, the Doppler shift causes a difference in

frequency during the up-ramp and the down-ramp. The target range is simply proportional to the sum of two peak frequencies and the target velocity is related to their difference. Measurements over longer ranges and demonstration of lidar's performance in measuring atmospheric winds and CO<sub>2</sub> concentration are planned in near future.

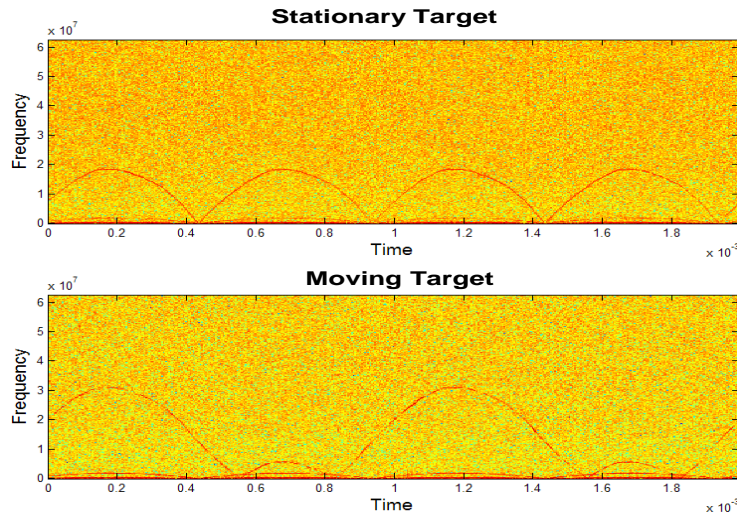

Figure 4. Spectrograms of the received signals from the sandpaper targets at 250 meters.

## CONCLUSION

A compact and efficient coherent lidar can greatly benefit future planetary missions by providing a number of critical data enabling autonomous precision landing. For this purpose, a breadboard all-fiber coherent lidar with multi-functional capability has been developed utilizing FM-CW, Doppler, DIAL techniques to provide precision range and velocity data for future robotic and manned planetary exploration missions, plus atmospheric wind and density data specifically for Mars missions. A prototype system is currently being designed that considers the size, mass, and power constraints of a planetary vehicle and addresses its operational requirements in providing real-time feedback to the guidance, navigation, and control system.

## REFERENCES

1. E.C. Wong, et al., "Autonomous Guidance and Control Design for Hazard Avoidance and Safe Landing on Mars.", AIAA Atmospheric Flight Mechanics Conference and Exhibit 5-8, 4619, Monterey, California, August 2002.
2. M.P. Golombek, Cook, R.A., et al., "Overview of the Mars Pathfinder Mission and Assessment of Landing Site Predictions," Science Magazine, 278: 1743–1748, December 5, 1997.
3. M.I. Skolnik, "Introduction to Radar Systems" 2<sup>nd</sup> ed., McGraw-Hill Book Company, New York, 1980.
4. A.L. Kachelmyer, "Range-Doppler imaging: wave-forms and receiver design," Proc. SPIE, vol. 999, pp., 138-161, 1988.
5. C.J. Karlsson, and F.A. Olsson "Linearization of the frequency sweep of a frequency-modulated continuous-wave semiconductor laser and the resulting ranging performance" App. Opt. Vol. 38, No. 15, pp 3376-3386 1999.
6. A.E. Johnson, et al., " Lidar-based Hazard Avoidance for Safe Landing on Mars." Journal of Guidance, Control, and Dynamics, Vol. 25 No. 6, Nov.-Dec. 2002.
7. G.J. Koch, et al., "Coherent differential absorption lidar measurements of CO<sub>2</sub>," Appl. Optics, vol. 43, pp 5092-5099, 2004.