

NASA/TM—2005-213893



# Development and Characterization Testing of an Air Pulsation Valve for a Pulse Detonation Engine Supersonic Parametric Inlet Test Section

Robert Tornabene  
Glenn Research Center, Cleveland, Ohio

---

October 2005

## The NASA STI Program Office . . . in Profile

Since its founding, NASA has been dedicated to the advancement of aeronautics and space science. The NASA Scientific and Technical Information (STI) Program Office plays a key part in helping NASA maintain this important role.

The NASA STI Program Office is operated by Langley Research Center, the Lead Center for NASA's scientific and technical information. The NASA STI Program Office provides access to the NASA STI Database, the largest collection of aeronautical and space science STI in the world. The Program Office is also NASA's institutional mechanism for disseminating the results of its research and development activities. These results are published by NASA in the NASA STI Report Series, which includes the following report types:

- **TECHNICAL PUBLICATION.** Reports of completed research or a major significant phase of research that present the results of NASA programs and include extensive data or theoretical analysis. Includes compilations of significant scientific and technical data and information deemed to be of continuing reference value. NASA's counterpart of peer-reviewed formal professional papers but has less stringent limitations on manuscript length and extent of graphic presentations.
- **TECHNICAL MEMORANDUM.** Scientific and technical findings that are preliminary or of specialized interest, e.g., quick release reports, working papers, and bibliographies that contain minimal annotation. Does not contain extensive analysis.
- **CONTRACTOR REPORT.** Scientific and technical findings by NASA-sponsored contractors and grantees.

- **CONFERENCE PUBLICATION.** Collected papers from scientific and technical conferences, symposia, seminars, or other meetings sponsored or cosponsored by NASA.
- **SPECIAL PUBLICATION.** Scientific, technical, or historical information from NASA programs, projects, and missions, often concerned with subjects having substantial public interest.
- **TECHNICAL TRANSLATION.** English-language translations of foreign scientific and technical material pertinent to NASA's mission.

Specialized services that complement the STI Program Office's diverse offerings include creating custom thesauri, building customized databases, organizing and publishing research results . . . even providing videos.

For more information about the NASA STI Program Office, see the following:

- Access the NASA STI Program Home Page at <http://www.sti.nasa.gov>
- E-mail your question via the Internet to [help@sti.nasa.gov](mailto:help@sti.nasa.gov)
- Fax your question to the NASA Access Help Desk at 301-621-0134
- Telephone the NASA Access Help Desk at 301-621-0390
- Write to:  
NASA Access Help Desk  
NASA Center for AeroSpace Information  
7121 Standard Drive  
Hanover, MD 21076

NASA/TM—2005-213893



# Development and Characterization Testing of an Air Pulsation Valve for a Pulse Detonation Engine Supersonic Parametric Inlet Test Section

Robert Tornabene  
Glenn Research Center, Cleveland, Ohio

National Aeronautics and  
Space Administration

Glenn Research Center

---

October 2005

## Acknowledgments

The author gratefully acknowledges Rene Fernandez and Paul Trimarchi, NASA Glenn Research Center, for making funding arrangements for the development, fabrication and testing of this challenging component design.

Also, thanks to Ray Kaliszewski, Ray Homyk, and Dan Kosareo, ZIN Technologies, Inc., for their technical involvement in the design; and to Mike Henry and Matt Laun, QSS Group, Inc., for providing operational expertise during the test sequence.

Available from

NASA Center for Aerospace Information  
7121 Standard Drive  
Hanover, MD 21076

National Technical Information Service  
5285 Port Royal Road  
Springfield, VA 22100

Available electronically at <http://gltrs.grc.nasa.gov>

# **Development and Characterization Testing of an Air Pulsation Valve for a Pulse Detonation Engine Supersonic Parametric Inlet Test Section**

Robert Tornabene  
National Aeronautics and Space Administration  
Glenn Research Center  
Cleveland, Ohio 44135

## **Abstract**

In pulse detonation engines, the potential exists for gas pulses from the combustor to travel upstream and adversely affect the inlet performance of the engine. In order to determine the effect of these high frequency pulses on the inlet performance, an air pulsation valve was developed to provide air pulses downstream of a supersonic parametric inlet test section. The purpose of this report is to document the design and characterization tests that were performed on a pulsation valve that was tested at the NASA Glenn Research Center (NASA Glenn) 1- by 1-Foot Supersonic Wind Tunnel (1×1 SWT) test facility. The high air flow pulsation valve design philosophy and analyses performed are discussed and characterization test results are presented.

The pulsation valve model was devised based on the concept of using a free spinning ball valve driven from a variable speed electric motor to generate air flow pulses at preset frequencies. In order to deliver the proper flow rate, the flow port was contoured to maximize flow rate and minimize pressure drop. To obtain sharp pressure spikes the valve flow port was designed to be as narrow as possible to minimize port dwell time.

## **Introduction**

Characterization tests of a pulsation valve were performed at the 1- by 1-Foot Supersonic Wind Tunnel (1×1 SWT) facility at the NASA Glenn Research Center (NASA Glenn). The pulsation valve was designed to provide air injection downstream of a supersonic inlet in an attempt to simulate downstream pulse detonation engine effects on the inlet flow stream. Based on the results of these pulsation valve characterization tests, a two-valve pulsating system was designed and fabricated for the Pulsed Parametric Inlet Technology (PPIT) test sequence and was tested with the supersonic inlet in the 1×1 SWT in 2004.

This pulsation valve system was designed as part of the NASA Glenn's Pulse Detonation Engine Technology (PDET) Propulsion Systems Base Program. The goal is to develop advanced PDE components as required to optimize system performance and demonstrate theoretical efficiencies in an appropriately scaled integrated systems test.

The initial pulsation valve and valve system requirements were generated based on discussions with the parametric inlet research team and are defined as follows:

- Valve system must have the capability to inject air pulses to the four corners of the test section downstream of the inlet (this requirement was later relaxed to two corners of the test section due to program funding constraints).
- Maximum flow capacity of each valve shall be 0.54 lbm/sec.
- Valve frequency shall be from 0 to 62 Hz, with a maximum of 100 Hz desirable.

- Air injection may be operated in varying sequences as follows:
  - (1) Each corner firing sequentially at the same frequency with a slight phase shift.
  - (2) Simultaneous injection at the top corners followed by another (out of phase) simultaneous injection at the bottom corners.
  - (3) Simultaneous injection at the left corners followed by another simultaneous injection at the right corners.
  - (4) Simultaneous injection at the top/side/bottom two corners at 1.08 lbm/sec (0.54 lbm/sec per corner).
- Develop as sharp of a pressure spike (square wave) as possible when the valve opens.
- Ports for the valves can go through either the sides or the top of the test section.
- Pulsation valves will need to be synchronized with the Schlieren system and the pressure measurement data.
- Air supply for the valves shall be taken from the 450 psig, 70 °F combustion air system in the test cell. The facility inlet control valve will be used to change flow rates to the pulsating valves. A subsonic venturi is present in the facility to measure the total air flow rate into the pulsating valves.
- The pressure in the test section during this test sequence will be a maximum of 20 psia
- The duty cycle shall be no greater than 16 percent (the duty cycle can be 33 percent when all ports are ganged together). The duty cycle is defined as the ratio of time that the valve is open during one open/close cycle.

## **Valve Development**

The valve development was undertaken after a thorough search for a commercial valve solution did not provide any candidate valves at the relatively high flow rates required. The pulsating valve design concept incorporates a rotating, slotted shaft that allows for two air pulses per revolution. The design is similar to a rotating ball valve, except that this design incorporates a slotted opening (rather than circular) to provide both the required air flow and as sharp of a flow spike as possible. Shaft seals are utilized at the outside edges of the flow slot to minimize axial leakage flow. Radial ball bearings are positioned on the ends of the shaft to absorb the loads due to the differential pressure force across the shaft. Bearing loads calculated were within an acceptable range to indicate infinite life. The inlet and discharge port contours were electrical discharge machined (EDM) to provide a smooth transition from the circular inlet and discharge ports to the narrow, slotted port in the shaft.

The slot in the valve shaft was designed for 10 percent excess flow, based on an assumed valve pressure drop of 150 psid. Circumferential leakage flow around the shaft was minimized by using a 0.003 in. diametral clearance between the housing and the shaft. A shaft fatigue analysis indicated that infinite life ( $10^6$  cycles or above) was attainable. An 18 percent nickel maraging steel alloy (Vascomax C-250) was used for the shaft material to increase the shaft fatigue life.

### **Valve Shaft Port and Fluid Passage Design and Analysis**

Since the pressure-flow characteristic of a pulsating valve is difficult to predict, an assumed pressure drop across the valve was used to estimate the required shaft slot flow area. Trade studies were performed by analyzing operating and design parameters at several different shaft diameters. This was an attempt to optimize the design with respect to shaft and bearing loads, bearing life, shaft seal performance and pulsating flow performance. The flow slot was designed narrow and long in an attempt to insure that the pressure pulse was as sharp as possible. This results in a longer portion of the shaft exposed to the cyclical pressure load, increasing stresses and reducing the shaft fatigue life. Also, as the slot length was increased, the bearing loads also increased due to the higher pressure load on the shaft and larger bearing spacing. The longer slot could also result in potential flow separation at the valve inlet and discharge, resulting in not attaining the required pulse flow.

If the shaft diameter was increased (with the same slot width) to reduce the duty cycle, the shaft seal surface speed increased, reducing the pressure-velocity (P-V) limits on the axial shaft seals, and increasing the potential for seal leakage. There was also a concern that the amount of time it takes for the flow to accelerate through a slot in a larger diameter shaft may have resulted in not fully achieving the flow capacity through the valve. Figure 1 depicts a view of the radial flow through the shaft.

After examining all operating parameters in the trade study, the final decision was to use a 1.00 in. shaft diameter with a 0.250 in. wide slot, resulting in a duty cycle of 15.9 percent. The resultant slot length to pass the maximum required flow rate was calculated as 2.35 in.

### **Inlet Port, Bearing Housing and Discharge Port Design**

The valve inlet port was designed to transition from a 1 in. Swagelok male connector fitting (0.875 in. circular shaped inlet port) to a 0.329-in.-wide by 2.07-in.-long inlet slot right before the flow enters the bearing housing. Due to the complex contour between these two cross sections, electrical discharge machining (EDM) of the internal passage was employed. An attempt was made to minimize the included angle ( $24^\circ$ ) in the inlet port to prevent potential flow separation. Two pressure taps were located in the valve inlet port to provide continuous inlet pressure signals to the ESCORT data recorder and to the high response, dynamic Kulite pressure transducer to determine the pulse frequency.

The bearing housing inlet port was designed to transition from the inlet port slot (0.329 in. wide by 2.07 in. long) to a slot that matched the slot in the shaft (0.25 in. wide by 2.35 in. long). The bearing housing discharge port transitioned from the same slot shape that was present in the shaft to a slot with dimensions of 0.331 in. wide by 2.07 in. long. This bearing housing also employed electrical discharge machining due to the complex internal port contour.

The diametral clearance between the bearing housing and the shaft was designed to be a maximum of 0.003 and a minimum of 0.0018 in. at assembly. The minimum clearance during operation of 0.0004 in. was based on the maximum calculated shaft deflection at worst case operating loads as well as the minimum assembly clearance. This clearance results in minimal circumferential air leakage around the shaft. A dry film lubricant was applied to the shaft at the bearing housing interface to protect the shaft in case of accidental rubbing.

The valve discharge port was designed to transition from a 0.331-in.-wide by 2.07-in.-long slot to a 0.504-in. wide by 1.117-in.-long oval. This part also required electrical discharge machining due to the complex internal port contour. An attempt was made to minimize the included angle in the discharge port to prevent potential flow separation. Two pressure taps were positioned in the valve discharge port to provide continuous valve discharge pressure signals to the ESCORT data recorder and to the dynamic Kulite pressure transducer to determine the pressure pulse amplitude and frequency.

Due to the various parting line interfaces between the fluid ports, the port dimensions through each part transition were gradually increased to prevent any forward facing steps from being present in the flow path. An engineering sketch of the pulsation valve concept showing the inlet and discharge port contours is presented in Figure 2. A cross sectional view of the PPIT pulsation valve assembly is presented in Figure 3.

### **Transition Simulation Piece Flow Passage Design**

Packaging considerations dictated that it would be advantageous to provide a separate transition piece between the pulsation valve and the strut ports where the air pulses are introduced to the test section. This part provides the necessary geometric transition from the valve discharge to the strut ports. Since the struts are structural members that are located in the supersonic flow path, the fluid port within the strut was restricted to be as narrow as possible to minimize potential flow blockage problems in the test section. The oval shaped flow port at the valve discharge needed to transition to the “90°-rotated” oval that is present in the strut. A transition piece was designed to simulate the actual flow passages (only a single flow passage was incorporated in the transition piece simulator used for valve characterization

testing—two separate flow passages would be present in each transition piece in the full scale system) that would be present downstream of the valve in the transition piece for the four valve test sequence. This part also required electric discharge machining due to the complex internal port contour.

### **Strut Simulation Piece Flow Passage Design**

For the inlet tests, two aft struts that support the test section incorporated two cored passages each to provide a route for the pulsed airflow. Since the struts add blockage to the inlet test section, they were designed to be as narrow as possible. This reduced the pulse flow cross sectional area available (oval shaped, with an area approximately equivalent to a 3/4 in. diameter) for each air supply feed. At the required air flow rate and temperature, the potential for choked flow in the strut flow passage existed, depending on the air pressure. Also, since the strut flow passage has curvature as well as a sharp 90° bend, it was hypothesized that the flow might choke at a lower flow rate than predicted. Calculations were performed to determine the minimum pressure in the strut to preclude the possibility of choking. Calculations showed that in order to pass the required flow, the air pressure in the strut flow passage needed to be kept above 50 psia. In order to maintain a relatively high pressure in the strut, a critical flow orifice was added at the downstream end of the strut flow passage as it discharges into the test section. Since different flow rates are desired for the PPIT test sequence, the orifices were designed to be removable so that different orifice sizes could be installed. For simplicity, the strut simulation piece was designed as a two-piece design with a single flow passage. The use of a two piece design with an O-ring seal eliminated the need for investment casting. An exploded view of the pulsation valve assembly with the transition piece and strut simulator is presented in Figure 4.

## **Mechanical Design**

### **Shaft Seal Analysis**

Shaft seals were utilized on each end of the shaft flow slot to prevent air from leaking axially from the pulsation valve assembly. The seals must seal against the maximum anticipated pressure difference of 450 psid across the seal, and operate at rotational speeds up to 3000 rpm. The valve port sizing tradeoff studies considered the “PV” value of the seal. The pressure difference across the seal,  $P$ , and the shaft surface speed,  $V_s$ , are the governing factors in determining the seal performance. Because of the relatively high differential pressure and rotational speed (at high frequencies), the shaft seals will be operating near the stated operating extremes (maximum operating  $PV = 208,700$  psi-fpm). After discussions with several seal manufacturers, it was decided that to maximize seal life, the shaft should be coated at the seal location with a tungsten carbide coating. The seal manufacturer recommended that the shaft surface finish at the seal location should be 6 min. rms maximum, with a 4 min. rms desirable with maximum runout of 0.002 in. (TIR). The shaft hardness recommendation was  $Rc = 65 - 70$ . This hardness is attained by using a tungsten carbide coating.

### **Radial Ball Bearing Analysis**

Since the differential pressure force across the shaft causes shaft bending, and the fact that there are no axial loads on the valve, deep groove radial ball bearings were selected for this application. For long life, the recommended bearing load capability should be 10 times greater than the operating load. However, this would have resulted in using very large bearings. Therefore, since the maximum bearing operating load prediction was conservative, bearings with a lower load carrying capability were utilized for this test sequence to minimize the bearing size.

The shaft was dimensioned to provide a slight press fit with the bearings. To aid in bearing removal, an anti-seize lubricant was applied to the shaft before bearing installation. For the selected bearing, the



manufacturer's specified minimum shoulder height for the shaft was 2.75 mm. However, this was in conflict with a design goal to minimize seal diameter. Therefore, a bearing spacer was added to provide a shoulder for the bearing inner race as shown in Figure 2. A surface finish of 16 min. rms was used on the shaft at the bearing area. Due to the relatively low operating speeds, internal grease lubrication was sufficient for the bearing. Double contact seals were used on the bearing to minimize potential contamination.

### **Shaft Bending Stress and Fatigue Analysis**

The shaft for this pulsation valve will undergo a large number of stress cycles due to rotation within the pressure field. A consumable electrode vacuum remelt maraging steel, Teledyne Allvac Vascomax C-250 was selected based on its excellent fatigue properties. This material was readily available in the diameter and lengths required. The material was ultrasonically tested before machining to insure that there were no material cracks or flaws.

Shaft bending stresses and deflections were calculated based on a conservative assumption of applying the maximum 450 psig inlet supply pressure across the entire shaft face (between the seals) and assuming that the pressure on the opposite (downstream) face is zero. This is conservative because there should be substantial backpressure on the downstream side of the shaft. It was also assumed that the shaft was simply supported between the two bearings. Shaft fatigue stresses were calculated at axial stations located at the center of the shaft (halfway between the bearings) and at the edge of the flow slot, since this is an area of high stress concentration. The maximum bending stress occurred at the center of the shaft with a resultant maximum deflection of 0.0015 in. Since the stresses were fully reversing, the calculated stress value was used in the shaft fatigue analysis. The alternating stress values used were taken from the bending stresses that were determined in the previous calculation for the slot edge. Both analyses predicted that the shaft fatigue life was well above the  $10^6$  cycle requirement for infinite shaft life.

### **Shaft Critical Speed Analysis**

A critical speed analysis was performed on the pulsating valve shaft. The vibration analysis was performed on the shaft with the slot oriented in both directions (i.e., slot directed upward, in the flowing direction, or slot directed horizontally, with the valve in the closed position). It was desirable for the first calculated natural frequency to be above the maximum shaft speed. The critical speed calculation showed that the first natural frequency of the shaft (in the worst case direction) was over 4600 Hz, well above the maximum shaft operating speed of 100 Hz.

### **Shaft Torsional Stress Analysis**

The pulsation valve torques consisted of aerodynamic torque on the shaft, bearing frictional torque, seal frictional torque and inertial torque. These torques were all determined at the worst case conditions and the shaft torsional stress was calculated based on these torques. The maximum torsional stress on the shaft was shown to be near 10 ksi, well below the allowable torsional stress for the Vascomax C-250 shaft material.

### **Valve Housing and Transition Piece Stress Analyses**

An ANSYS analysis of the valve housing was performed to determine the maximum housing stress for the operating pressure of 450 psig as well as verification (hydrostatic) testing at  $1.5 \times$  design pressure. The structural model consisted of the valve inlet port, the bearing housing and the valve discharge port. Since the structure is symmetrical about the flow path centerline, only one-fourth of the structure was modeled and analyzed in ANSYS to minimize computation time. The maximum stresses calculated were approximately 14 ksi, well below the 30 ksi allowable stress for the 304 stainless steel housing. The stress

analyses of the bolts that attach the inlet and discharge ports to the bearing housing showed that the maximum bolt stresses were approximately 17 ksi, well below the 85 ksi allowable stress for the Grade 5 bolts.

In order to insure safe operation in the test cell, an ANSYS stress analysis of the transition piece was also performed at the maximum internal hydrostatic test pressure of 675 psig. The maximum stresses calculated were approximately 2.5 ksi, well below the 30 ksi allowable stress for the 304 stainless steel transition piece.

### **Valve Drive System**

The electric motor was sized with sufficient capacity to overcome the pulsation valve maximum torque. The pulsation valve torques consists of aerodynamic torque on the shaft, bearing frictional torque, seal frictional torque and inertial torque. The maximum required motor torque calculated was 85 in.-lb (approx. 4.05 hp at 3000 rpm). The calculated aerodynamic torque accounted for approximately 98 percent of the total required motor torque. The torque due to bearing and seal friction was essentially negligible. For the pulsation valve characterization test, a less expensive motor controller was selected for use. A flexible coupling was used between the motor and valve to minimize potential shock loads that may occur due to the pressure pulses. A motor encoder was added to the end of the shaft to monitor motor speed.

### **Pulsation Valve Test Facility**

The air inlet for the PPIT pulsation valve characterization test was taken from the 450 psig combustion air supply. The piping branch started from a 2 in. flange above the test section. A flexible hose provided the final connection to the pulse valve inlet. For the characterization test sequence, the pulsation valve discharged into a 3 in. diameter exhaust bleed line in the test cell. There was a mass flow plug in the exhaust bleed line to provide a varying backpressure as low as 0.5 psia. A 16 in. spool section was fabricated to mount to the exhaust bleed line to provide packaging clearance from the 6 in. pipe that is just below the exhaust bleed line. This allowed the valve and motor mounting hardware to be supported from the floor.

An instrumentation flange was also fabricated to provide for a pitot tube total pressure measurement and a static pressure measurement just downstream of the pulsating valve. The total and static pressure measurements were also taken at the same axial plane within the flange. Each pressure port was routed to an ESCORT data recorder and to a Kulite dynamic pressure transducer to provide high frequency pressure measurement capability.

A modified blind flange was fabricated and connected upstream of the instrumentation flange to provide the pulsation valve discharge port mounting interface. Two other blind flanges were fabricated, one to accept the transition piece mounting interface and one for the strut mounting, to individually test the damping effects of the transition piece and strut.

### **Pulsation Valve Characterization Tests**

The objective of the pulsation valve characterization tests were to characterize the valve performance at various operating conditions and determine if it would be suitable for providing pulsed air flow disturbances upstream of a supersonic inlet. Several of these valves would then be used to simulate the effects of a pulse detonation engine on the supersonic inlet performance.

For the characterization testing, instrumentation measurements were made on parameters pertinent to the valve performance. The pulsation valve pressure measurements were recorded using the standard ESCORT system as well as recording dynamic pressures (at a rate of 100,000 readings/sec) using Kulite

pressure transducers connected to the DATAMAX processor. The parameters measured included shaft speed, valve static inlet pressure, valve static discharge pressure, valve total discharge pressure (using the pitot tube positioned at valve discharge flange, transition piece discharge port or strut discharge port), valve air inlet temperature, valve mass flow rate (using facility venturi), transition piece static pressure and exhaust bleed line pressure (simulated the test section pressure).

### **Test Set-Up and Test Matrix**

The pulsation valve testing was performed in the 1-NW test cell at NASA Glenn using the 450 psig inlet supply at a nominal inlet temperature of 70 °F. The appropriate discharge port was mounted to the instrumentation flange that was connected to the exhaust bleed line that dumps into the altitude exhaust system. A mass flow plug existed on the downstream portion of the exhaust bleed line to provide varying backpressure regulation capability. Since the air supply for the pulsation valve test was taken from the 450 psig combustion air system, upstream flow measurement was also available using the existing venturi in the 450 psig system supply line for mass flow rate verification.

Thorough testing of the pulsation valve consisted of a number of configurations with either the valve, transition piece or strut was mounted directly to the instrumentation ring flange based on the specific data to be retrieved. Flexible hose was used to make the final connection from the 450 psig supply to the pulsation valve inlet. The pulsation valve test matrix consisted of testing each configuration at a range of inlet pressures (100, 200, 300, 400, and 450 psig), a range of shaft speeds (1200, 1800, 2400, and 3000 rpm), and at two different backpressures (one between 5 and 10 psia and one between 10 to 15 psia).

### **Test Data Summary**

#### **Pulsation Valve Tests**

Pulsation valve characterization testing was started on December 12, 2002. The initial test was run with the pulsation valve mounted directly on the instrumentation flange without the transition and strut simulation pieces attached. The pulsation valve shaft was locked in the open position to determine the valve pressure-flow characteristic at a range of inlet and discharge pressures in order to compare the actual performance against the calculations. Another test was performed with the valve shaft locked with the port in the closed position in order to quantify the circumferential leakage around the shaft. It was found that the circumferential leakage around the valve shaft was negligible.

On December 13, a full test sequence was completed with the pulsation valve only. A drawing of the pulsation valve test set-up is presented in Figure 5. The test sequence included operating the pulsation valve at a range of inlet pressures from 100 to 450 psia, two different backpressures from 5 to 20 psia, and a range of speeds from 600 to 3000 rpm (20 to 100 Hz). The pulses from the valve were causing large deflections in the inlet piping at 600 rpm due to resonance. Therefore, testing at this low frequency was discontinued since this was not a frequency required by research.

On December 18, a full test sequence was completed with the transition piece attached downstream of the pulsation valve and mounted directly to the instrumentation flange. A drawing of this test set-up is presented in Figure 6. On December 19, another full test sequence was completed with the pulsation valve, transition piece and strut simulation piece (with a 0.375 in. orifice installed). A drawing of the test set-up with the valve, transition piece and strut simulator is presented in Figure 7. Preliminary review of the test data indicated that the pressure pulses were heavily damped with this configuration. The test was repeated with the orifice removed (the strut opening with the orifice removed was 0.75 in. diameter). The pressure pulses were significantly less damped with the orifice removed and it was determined that the critical flow orifice was not needed in the strut.

Due to project funding and time constraints, only a small portion of the data was chosen for post processing and presentation in this report. After discussions with research personnel, it was decided that the only data presented would be limited to static and total components of the dynamic pressure field

(pulse) downstream of the valve along with the respective calculated mass flow rates (based on the measured pressure ratio and the flow area at the instrumentation ring). This data is presented for tests with full inlet pressure to the valve (approx. 450 psig) and at shaft speeds of 1800 rpm (60 Hz) and 3000 rpm (100 Hz).

Figure 8 shows the total exit pressure from the pulsation valve only and the entire assembly at 3000 rpm (100 Hz) with and without the orifice installed. The effect of orifice damping is evident by the much smaller discharge pressure spikes when the orifice is present. Figure 9 presents similar results at 1800 rpm (60 Hz). The configuration with the prototype pulse valve and transition piece only is not presented, since this test was performed only to characterize the transition piece.

Figure 10 shows the pulsation valve mass flow rate as a function of time for the 3000 rpm (100 Hz) case. The mass flow rate is calculated based on exit flow Mach number through the instrumentation ring, which is a function of the static and total pressure ratios. From the Mach number and the instrumentation ring flow area, the mass flow rate is determined. Due to the high frequency pulses, the flow rate when the valve is closed never settles out to zero. Figure 11 shows a similar plot at 1800 rpm (60 Hz).

Figure 12 presents various pulsation valve pressure measurements as a function of time at 3000 rpm (100 Hz). Note that the valve static inlet pressure scale is on the left axis and all other measurements are scaled from the right axis. Even though the pulsation valve inlet pressure was near 450 psig for this test, inlet pressure spikes were measured at over 650 psi. It was hypothesized that this phenomena was due to pressure waves reflecting back upstream from the test pipe that was used for the characterization tests. This phenomena would not exist when the pulsation valve was mounted to the test section, where the pressure spikes would quickly diffuse. Figure 13 presents similar results at 1800 rpm (60 Hz).

Figure 14 presents pulsation valve discharge pressures as a function of time at 3000 rpm (100 Hz) for the entire valve assembly (valve, transition piece and strut simulator). Note that there is very little pressure energy dissipated between the pulsation valve discharge port and the instrumentation pressure measurement. Figure 15 presents similar pressure data at 1800 rpm (60 Hz).

## Conclusions

A pulsation valve was conceived, designed and fabricated to provide high frequency air injection pulses downstream of a supersonic test section. Characterization tests of the pulsation valve were performed at the 1×1 SWT Facility at NASA Glenn. The characterization tests showed that the pulsation valve met all research requirements and would be suitable for simulation of downstream pulse detonation engine effects on the inlet supersonic flow stream. Based on the results of these pulsation valve characterization tests, a two-valve pulsating system was fabricated and was tested with a parametric supersonic inlet in the 1×1 SWT in 2004.

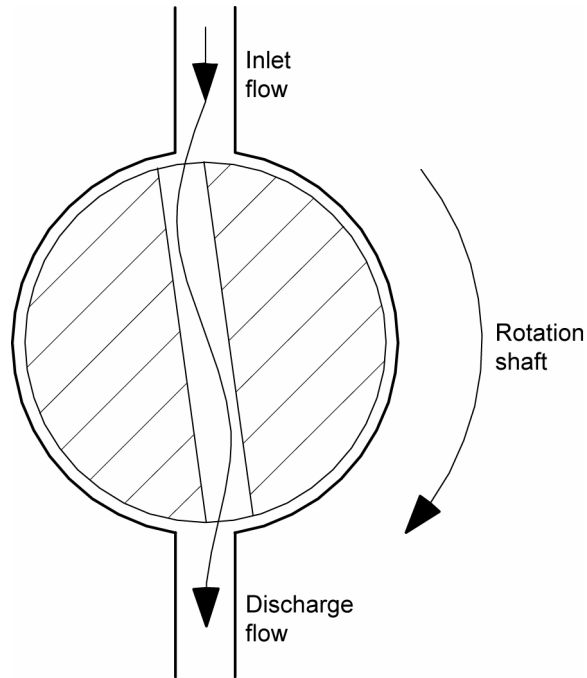

Figure 1.—Pulsed radial flow through the shaft.

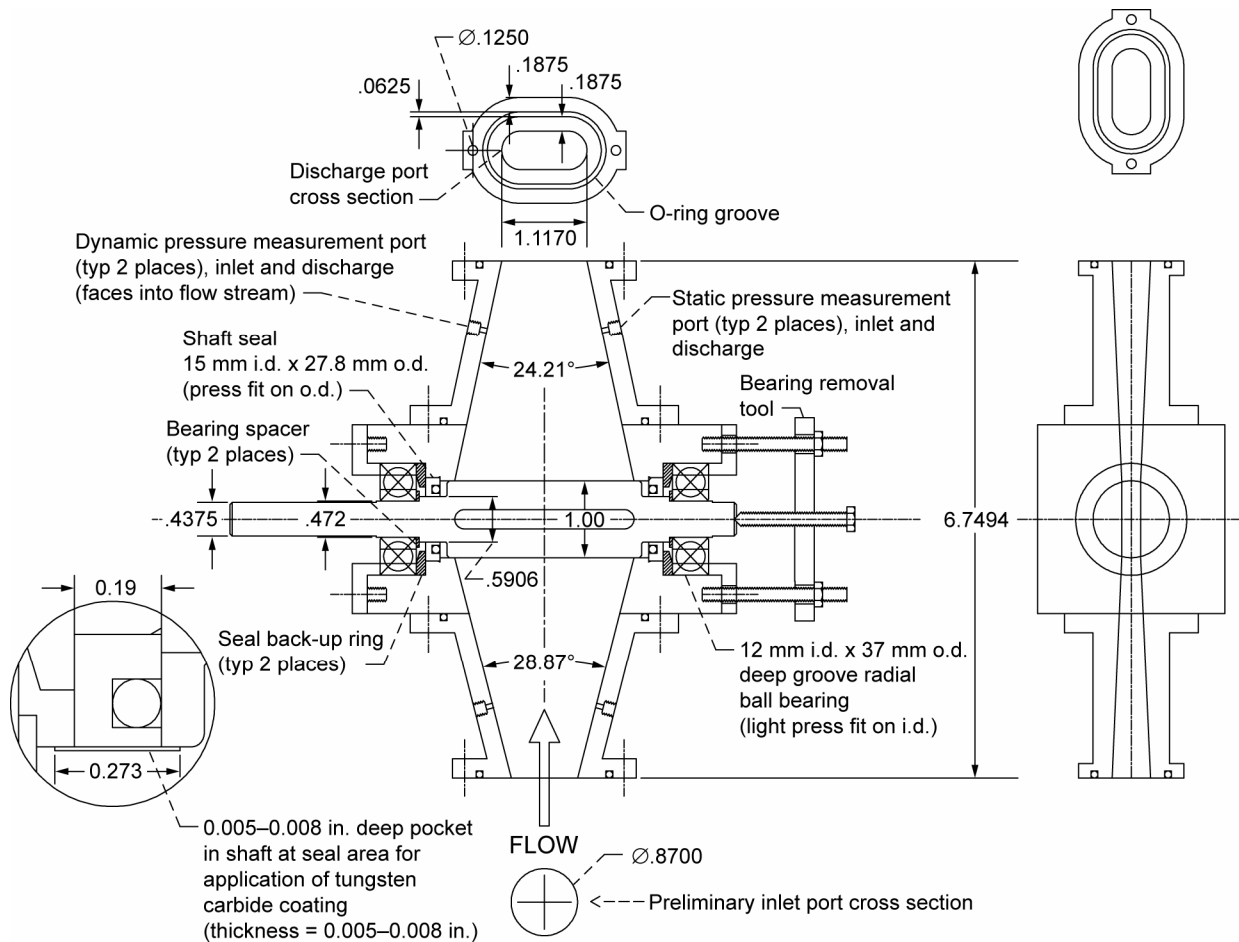

Figure 2.—Pulsation valve concept showing inlet and discharge port contours.

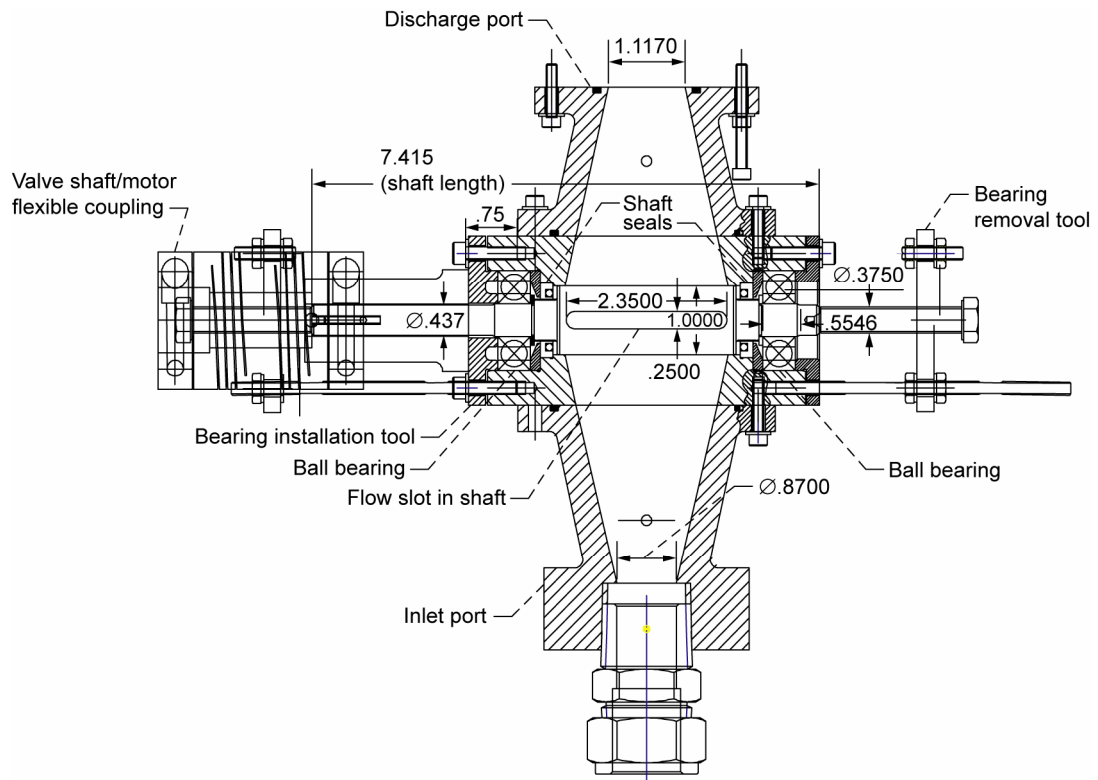

Figure 3.—Pulsation valve assembly cross section.

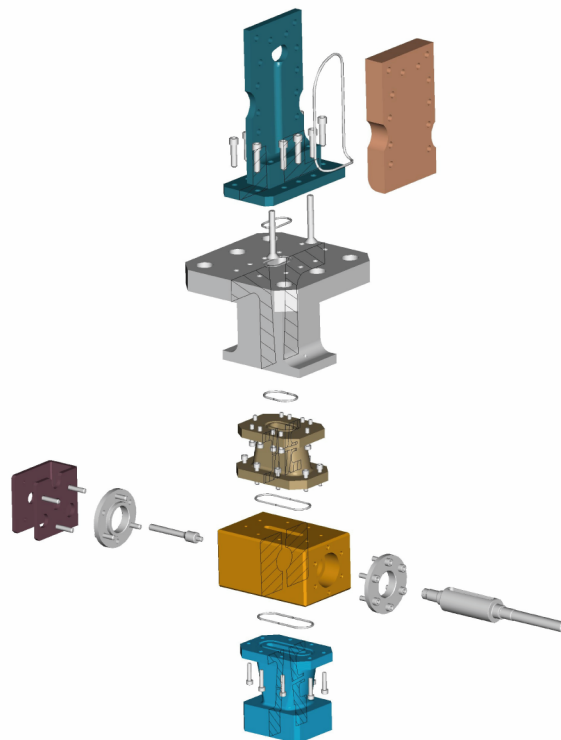

Figure 4.—Pulsation valve assembly exploded view with transition piece and strut simulator.

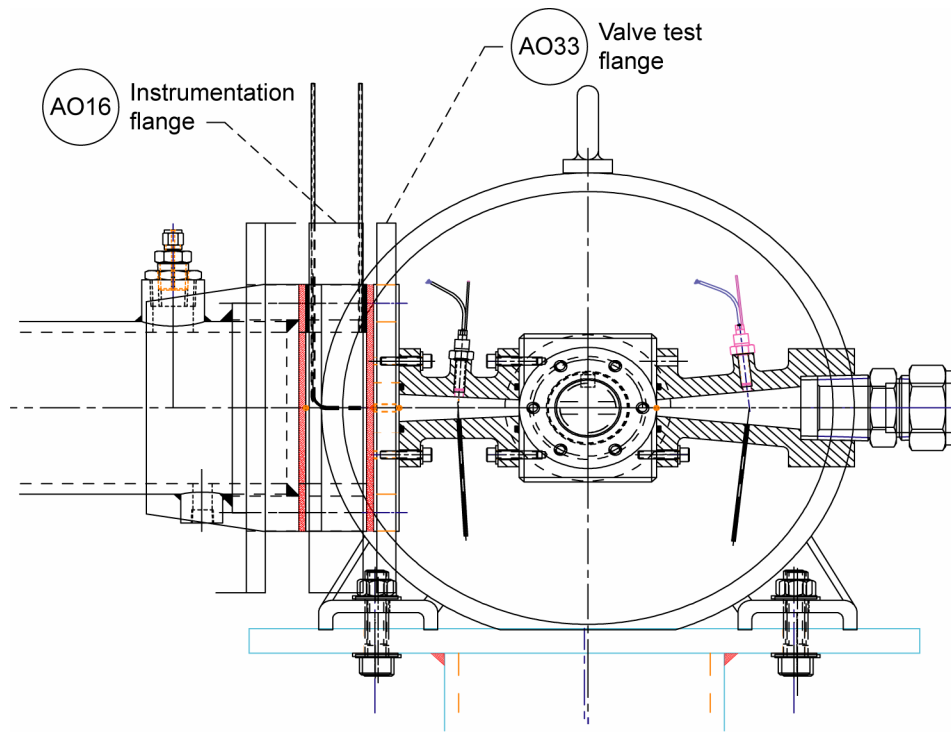

Figure 5.—Pulsation valve mounted on test pipe.

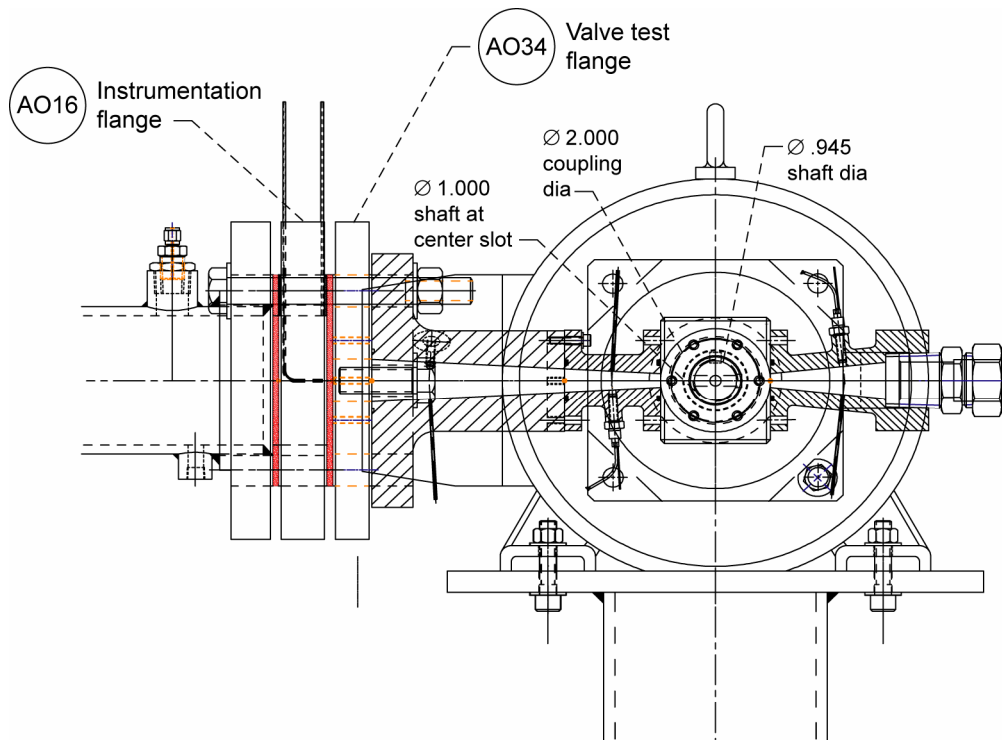

Figure 6.—Pulsation valve with transition piece mounted on test pipe.

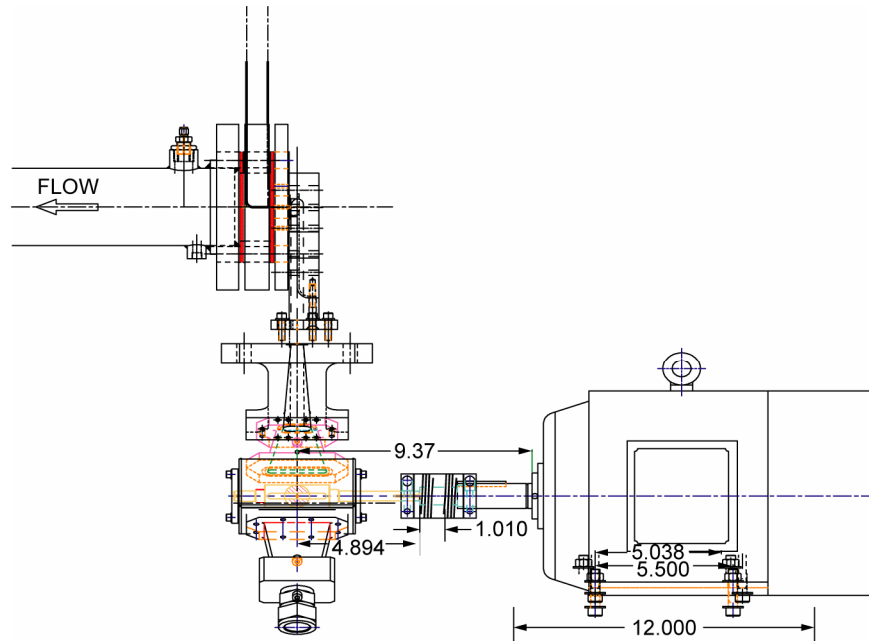

Figure 7.—Pulsation valve with transition piece and strut simulator mounted on test pipe.

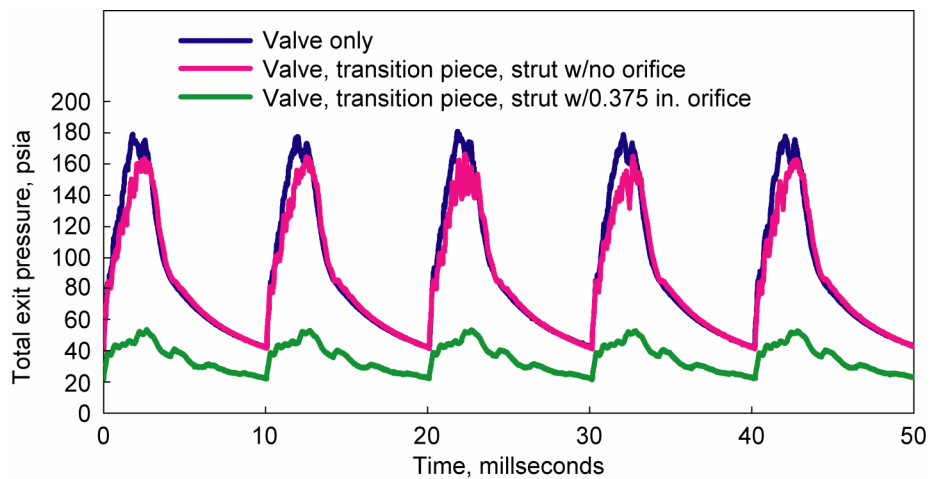

Figure 8.—Pulsation valve pressure pulse test data, 3000 rpm, 100 Hz.



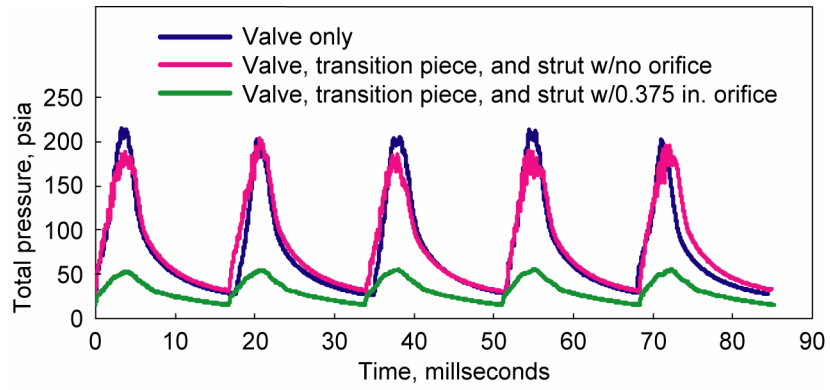

Figure 9.—Pulsation valve pressure pulse test data, 1800 rpm, 60 Hz.

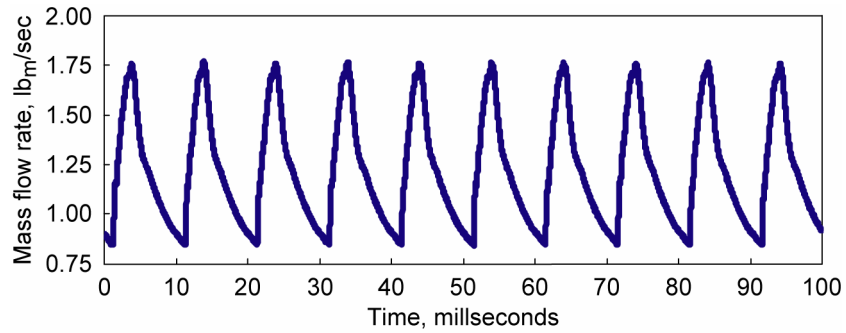

Figure 10.—Pulsation valve mass flow test data, 3000 rpm, 100 Hz.

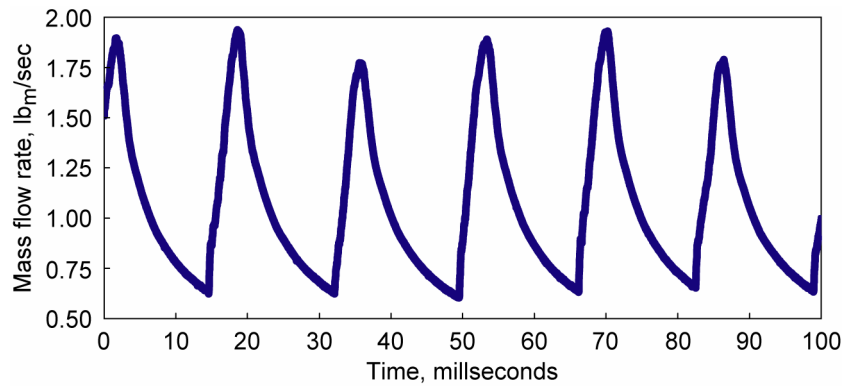

Figure 11.—Pulsation valve mass flow test data, 1800 rpm, 60 Hz.

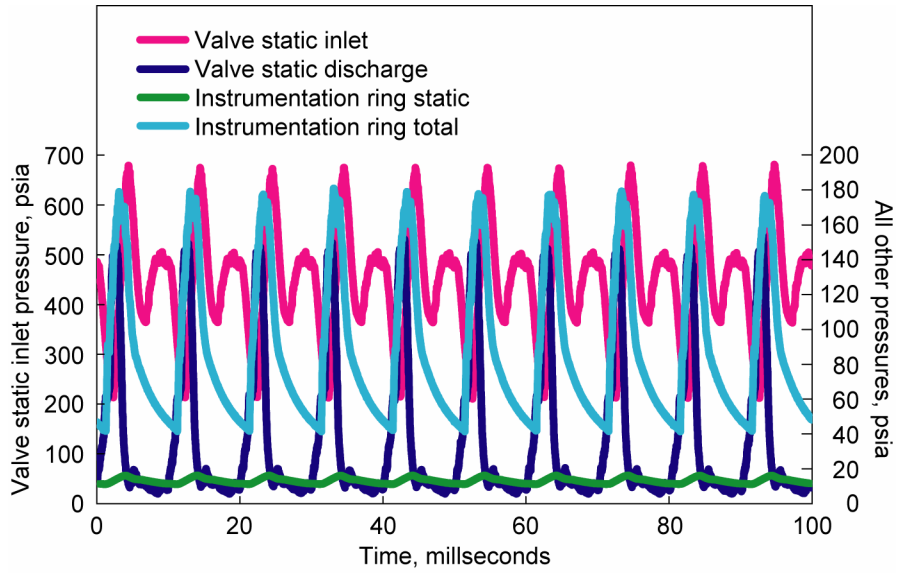

Figure 12.—Pulsation valve pressure test data, 3000 rpm, 100 Hz.

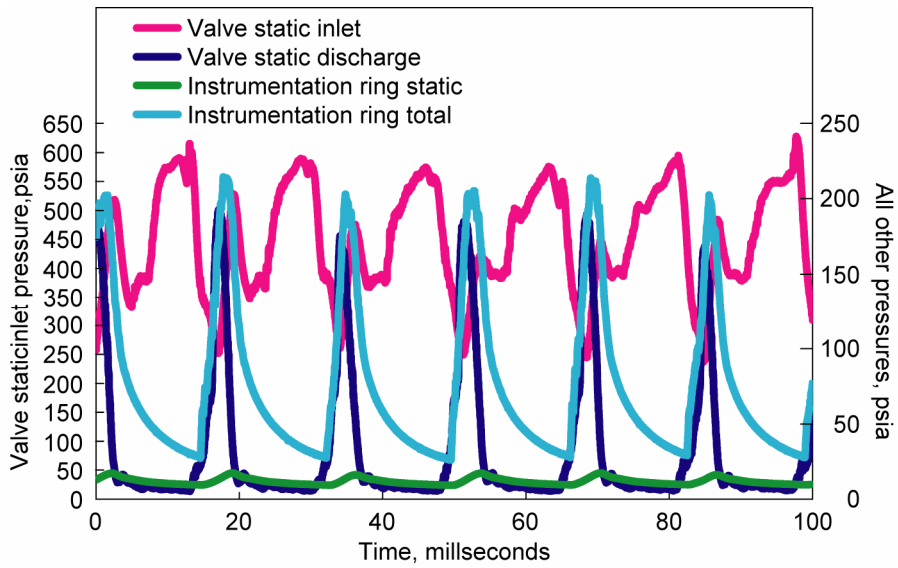

Figure 13.—Pulsation valve pressure test data, 1800 rpm, 60 Hz.

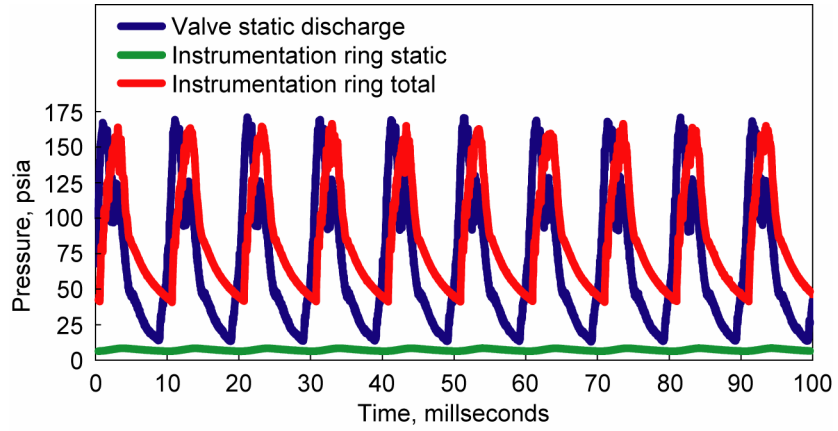

Figure 14.—Pulsation valve assembly pressure test data, 3000 rpm, 100 Hz.

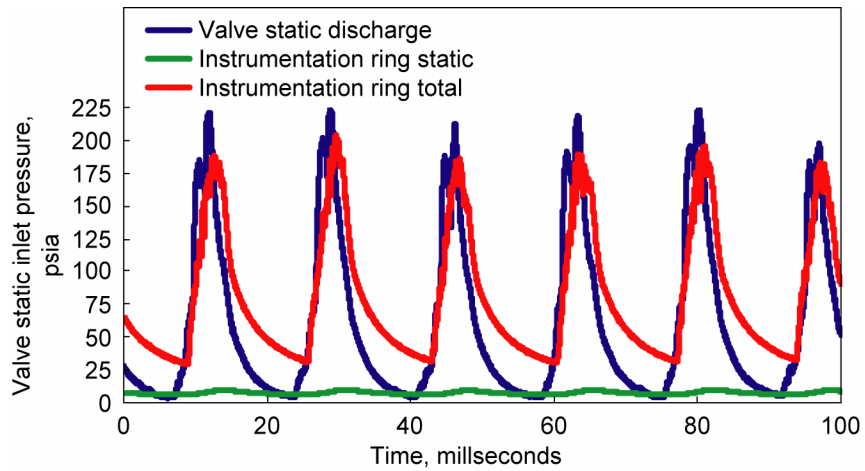

Figure 15.—Pulsation valve assembly pressure test data, 1800 rpm, 60 Hz.

**REPORT DOCUMENTATION PAGE**Form Approved  
OMB No. 0704-0188

Public reporting burden for this collection of information is estimated to average 1 hour per response, including the time for reviewing instructions, searching existing data sources, gathering and maintaining the data needed, and completing and reviewing the collection of information. Send comments regarding this burden estimate or any other aspect of this collection of information, including suggestions for reducing this burden, to Washington Headquarters Services, Directorate for Information Operations and Reports, 1215 Jefferson Davis Highway, Suite 1204, Arlington, VA 22202-4302, and to the Office of Management and Budget, Paperwork Reduction Project (0704-0188), Washington, DC 20503.

<b>1. AGENCY USE ONLY (Leave blank)</b>		<b>2. REPORT DATE</b> October 2005	<b>3. REPORT TYPE AND DATES COVERED</b> Technical Memorandum	
<b>4. TITLE AND SUBTITLE</b> Development and Characterization Testing of an Air Pulsation Valve for a Pulse Detonation Engine Supersonic Parametric Inlet Test Section			<b>5. FUNDING NUMBERS</b>  Cost Center 2277000012	
<b>6. AUTHOR(S)</b>  Robert Tornabene				
<b>7. PERFORMING ORGANIZATION NAME(S) AND ADDRESS(ES)</b>  National Aeronautics and Space Administration John H. Glenn Research Center at Lewis Field Cleveland, Ohio 44135-3191			<b>8. PERFORMING ORGANIZATION REPORT NUMBER</b>  E-15264	
<b>9. SPONSORING/MONITORING AGENCY NAME(S) AND ADDRESS(ES)</b>  National Aeronautics and Space Administration Washington, DC 20546-0001			<b>10. SPONSORING/MONITORING AGENCY REPORT NUMBER</b>  NASA TM-2005-213893	
<b>11. SUPPLEMENTARY NOTES</b>  Responsible person, Robert Tornabene, organization code DEC, 216-433-3045.				
<b>12a. DISTRIBUTION/AVAILABILITY STATEMENT</b>  Unclassified - Unlimited Subject Categories: 02 and 07  Available electronically at <a href="http://gltrs.grc.nasa.gov">http://gltrs.grc.nasa.gov</a>  This publication is available from the NASA Center for AeroSpace Information, 301-621-0390.			<b>12b. DISTRIBUTION CODE</b>	
<b>13. ABSTRACT (Maximum 200 words)</b>  In pulse detonation engines, the potential exists for gas pulses from the combustor to travel upstream and adversely affect the inlet performance of the engine. In order to determine the effect of these high frequency pulses on the inlet performance, an air pulsation valve was developed to provide air pulses downstream of a supersonic parametric inlet test section. The purpose of this report is to document the design and characterization tests that were performed on a pulsation valve that was tested at the NASA Glenn Research Center 1x1 Supersonic Wind Tunnel (SWT) test facility. The high air flow pulsation valve design philosophy and analyses performed are discussed and characterization test results are presented. The pulsation valve model was devised based on the concept of using a free spinning ball valve driven from a variable speed electric motor to generate air flow pulses at preset frequencies. In order to deliver the proper flow rate, the flow port was contoured to maximize flow rate and minimize pressure drop. To obtain sharp pressure spikes the valve flow port was designed to be as narrow as possible to minimize port dwell time.				
<b>14. SUBJECT TERMS</b>  Pulse detonation engines; Gas valves; Fluid controls; Air jets			<b>15. NUMBER OF PAGES</b> 21	
			<b>16. PRICE CODE</b>	
<b>17. SECURITY CLASSIFICATION OF REPORT</b> Unclassified	<b>18. SECURITY CLASSIFICATION OF THIS PAGE</b> Unclassified	<b>19. SECURITY CLASSIFICATION OF ABSTRACT</b> Unclassified	<b>20. LIMITATION OF ABSTRACT</b>	



