



Current Progress on the Design and Analysis
of the JWST ISIM Bonded Joints
for Survivability at Cryogenic Temperatures

Andrew Bartoszyk, Swales Aerospace
FEMCI 2005 Workshop
May 5, 2005



JWST/ISIM Stress Team



Andrew Bartoszyk, Swales Aerospace – Stress Analysis

John Johnston, NASA GSFC – Analysis Lead

Charles Kaprielian, Swales Aerospace – Stress Analysis

Cengiz Kunt, Swales Aerospace – Stress Analysis Lead

Joel Proebstle, Swales Aerospace – Stress Analysis

Benjamin Rodini, Swales Aerospace – Composite Materials

Daniel Young, Swales Aerospace – Stress Analysis



Design and Analysis Challenges



- Design Requirements
 - Metal/composite bonded joints required at a number of nodal locations on the JWST/ISI composite truss structure to accommodate bolted instrument interfaces and flexures.
 - Survival temperature at 22K ($\sim -400^{\circ}\text{F}$); -271K total ΔT from RT.
 - Composite truss tube with high axial stiffness (~ 23 msi) and low axial CTE (~ 0 ppm/K).
 - Multiple thermal cycles throughout design life of structure. In order to survive launch loads, joints cannot degrade more than an acceptable amount.
- Design/Analysis Challenges
 - Large thermal mismatch stresses between metal fitting and composite tube at cryogenic temperatures (22K).
 - Analysis and design experience is very limited for metal/composite bonded joints at temperatures below liquid nitrogen ($\sim 80\text{K}$).
 - Thermo-elastic material properties and strengths for composites and adhesives at 22K are not available and difficult to test for.



ISIM Basic Joint Assemblies

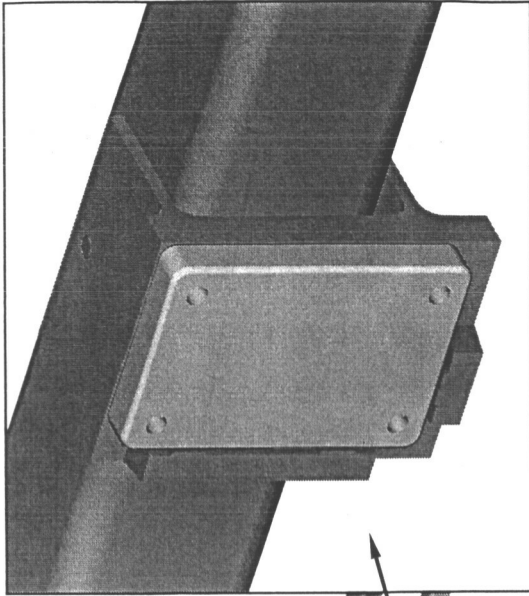

Saddle

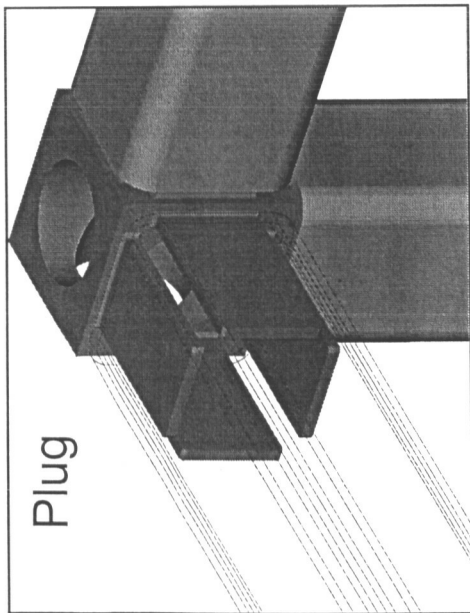

Plug

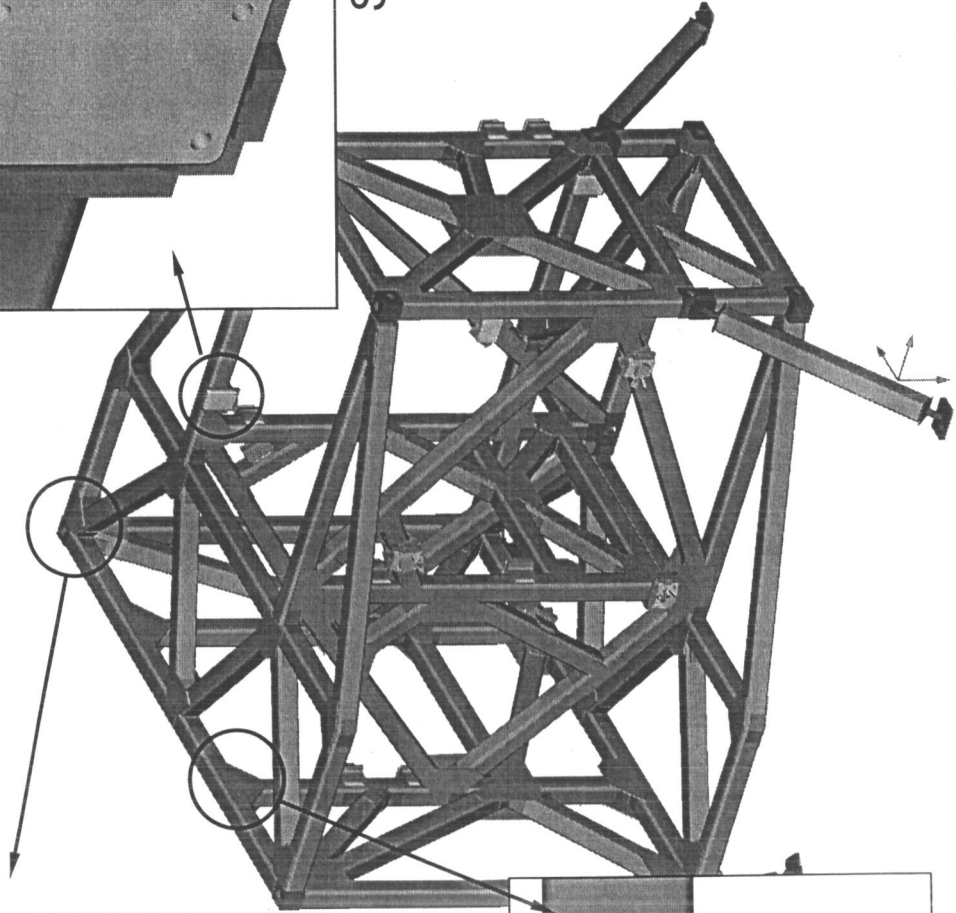

T-Joint (Gusset & Clips)

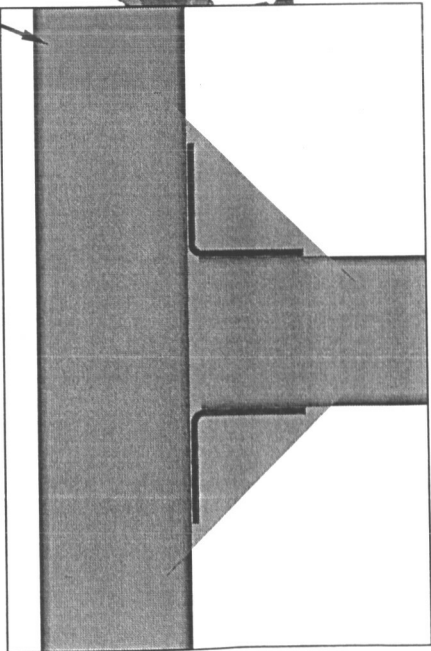

Basic Plug Joint Details

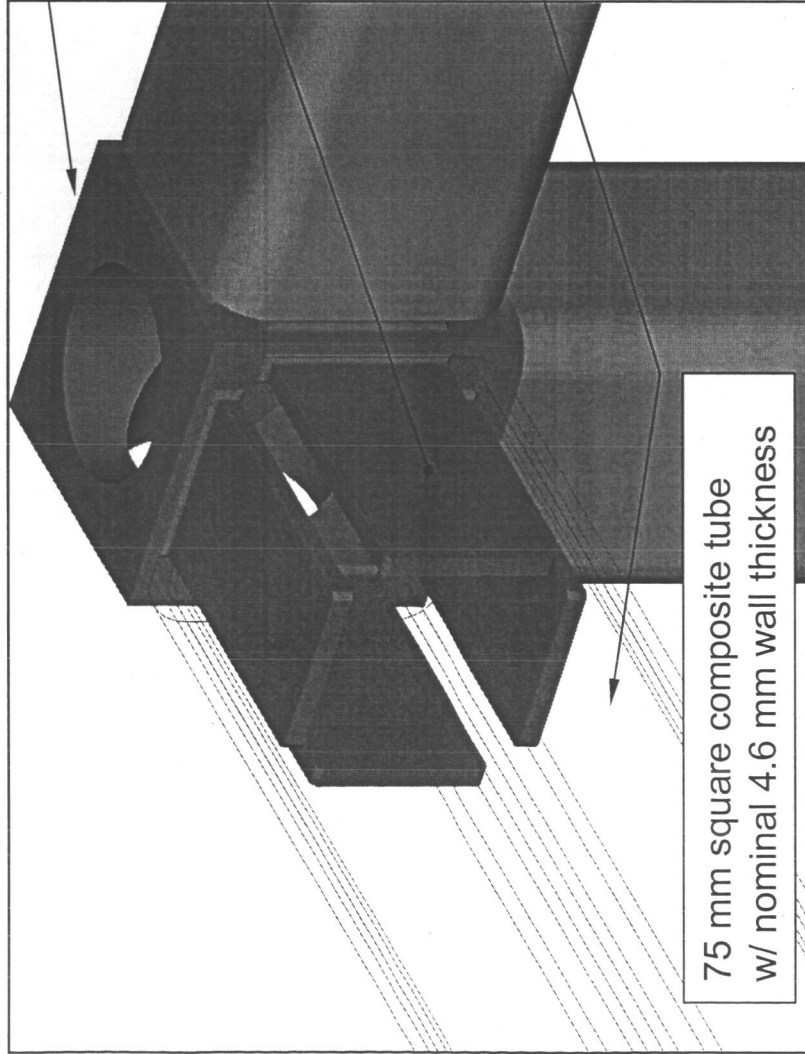

Metal Fitting (Invar 36)

$E = 18.8 \text{ msi}$

$\alpha = +1.5 \text{ ppm/K}$

Adhesive Bond (EA9309)

$E = 1.1 \text{ msi}$

$G = 0.4 \text{ msi}$

$\alpha = 47.8 \text{ ppm/K}$

$F_{su} = 11.6 \text{ ksi (80 MPa)}$

Composite Tube

Hybrid Laminate: $[60^2/0^1/-60^2/0^1]_{SN}$,

$^1M55J/954-6, ^2T300/954-6$

$E_{axial} = 23 \text{ msi}$

$E_{hoop} = 6.7 \text{ msi}$

$\alpha_{axial} = -0.13 \text{ ppm/K}$

$\alpha_{hoop} = +3.7 \text{ ppm/K}$

$S_{zz} = 2.9 \text{ ksi (20 MPa)}$ } interlaminar

$S_{zy} = S_{yz} = 5.8 \text{ ksi (40 MPa)}$ } strengths

- Stiffness and strength properties are given for 22K.
- Thermal expansion properties are secant CTE from RT to 22K.



Bonded Joint Design & Sizing Flow

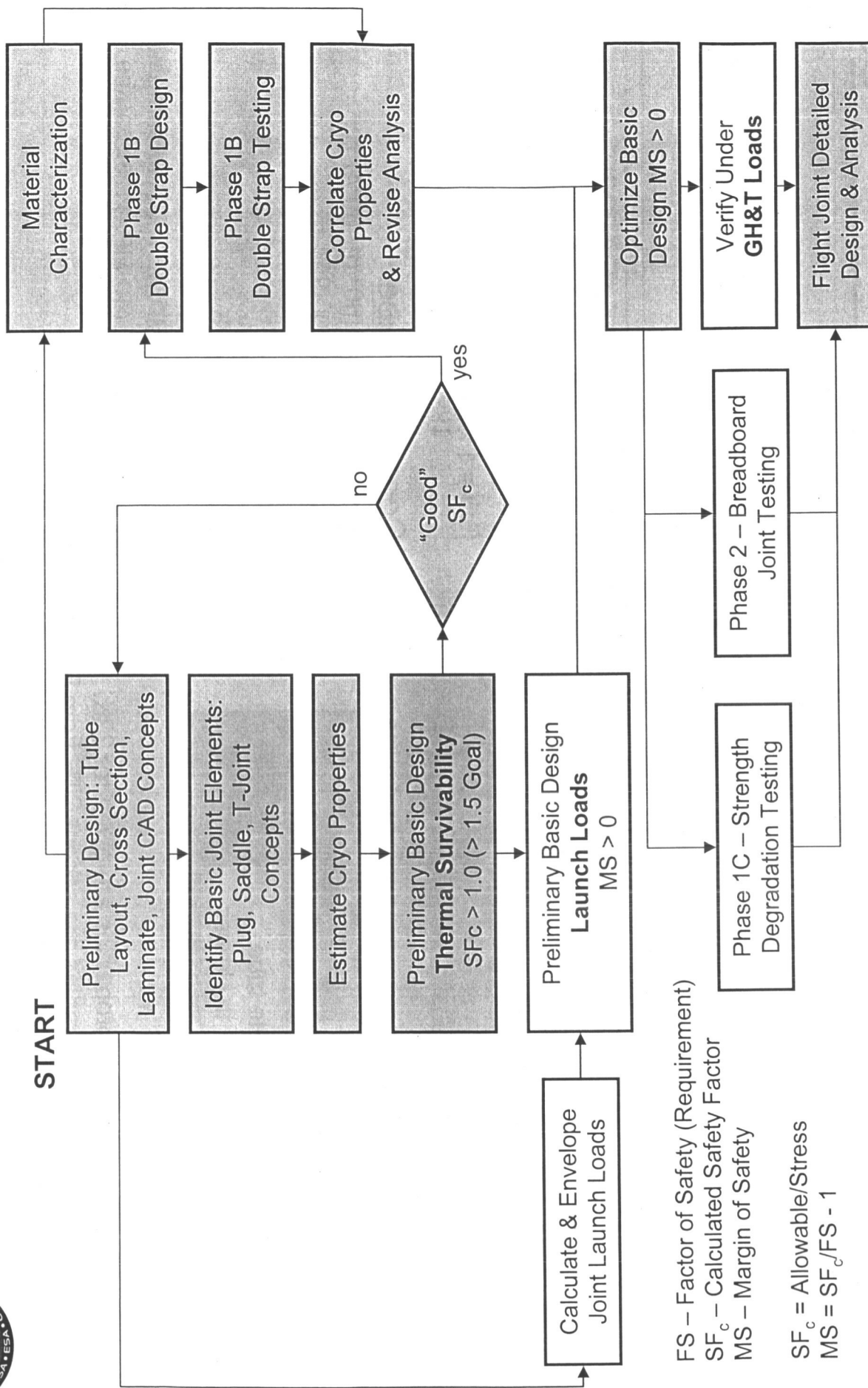

FS – Factor of Safety (Requirement)

SF_c – Calculated Safety Factor

MS – Margin of Safety

$SF_c = \text{Allowable}/\text{Stress}$

$MS = SF_c/FS - 1$

Composite Modeling and Mesh Size

- Mesh size: 2.5 mm square in-plane
- Surface plies at bonded interfaces modeled individually
- Aspect ratio $\cong 2.5/0.071 \cong 35$
- Laminate core modeled with thicker elements
- Adhesive modeled with one element through the thickness
- Same mesh size used in all joint FEMs including development test FEMs
- Stress recovery: Element centroid for interlaminar, corner for others

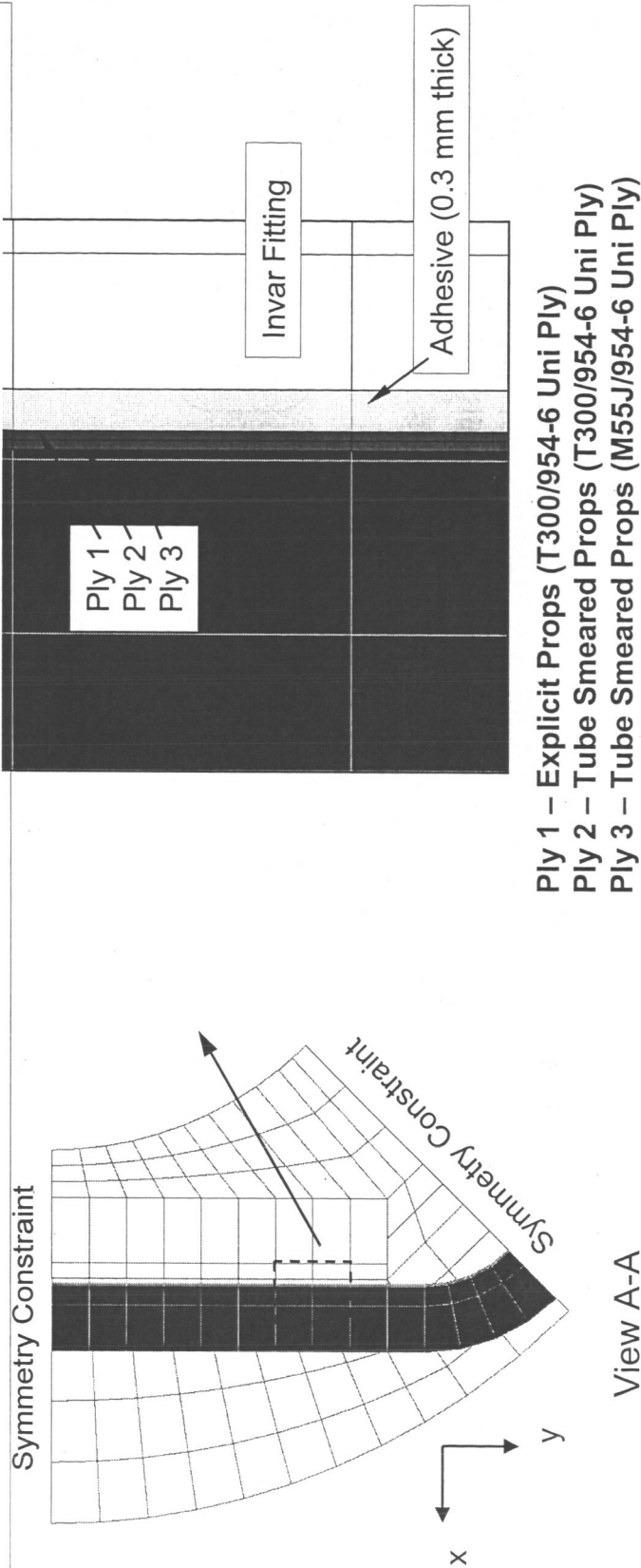

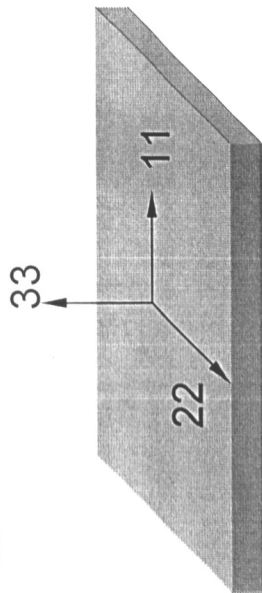

Under thermal loads, metal/composite bonded joints typically fail in composite interlaminar stresses.

$$\left(\frac{\sigma_{33}}{F_{33}}\right)^2 + \left(\frac{\tau_{RSS}}{F_{RSS}}\right)^2 = 1$$

$$\left(\frac{\sigma_{33}}{F_{33}}\right)^2 + \left(\frac{\tau_{13}}{F_{13}}\right)^2 + \left(\frac{\tau_{23}}{F_{23}}\right)^2 = 1$$

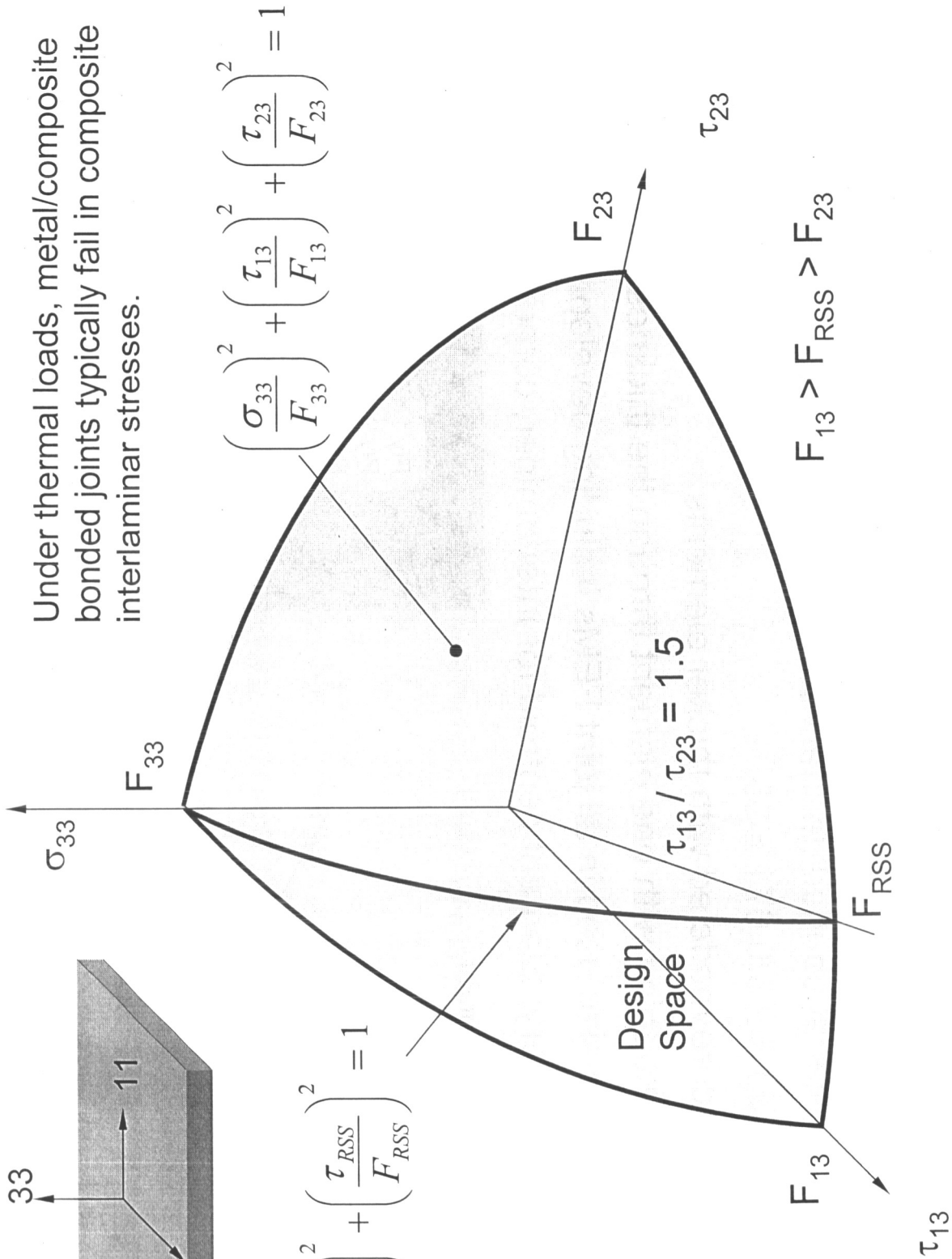

An empirical Interlaminar Failure Criterion is used for critical lamina:

$$\left(\frac{\sigma_{33}}{F_{33}} \right)^2 + \left(\frac{\tau_{RSS}}{F_{RSS}} \right)^2 = 1$$

where σ_{33} is peel stress, τ_{RSS} is resultant transverse shear stress, and F terms are material constants dependent on interlaminar strengths, which are being determined by testing.

Margin Calculations

Stress State 1

$$MS = \frac{1}{FS \cdot \sqrt{\left(\frac{\sigma_{33}}{F_{33}} \right)^2 + \left(\frac{\tau_{RSS}}{F_{RSS}} \right)^2}} - 1$$

Stress State 2

$$MS = \frac{F_{RSS}}{FS \cdot \tau_{RSS}} - 1$$

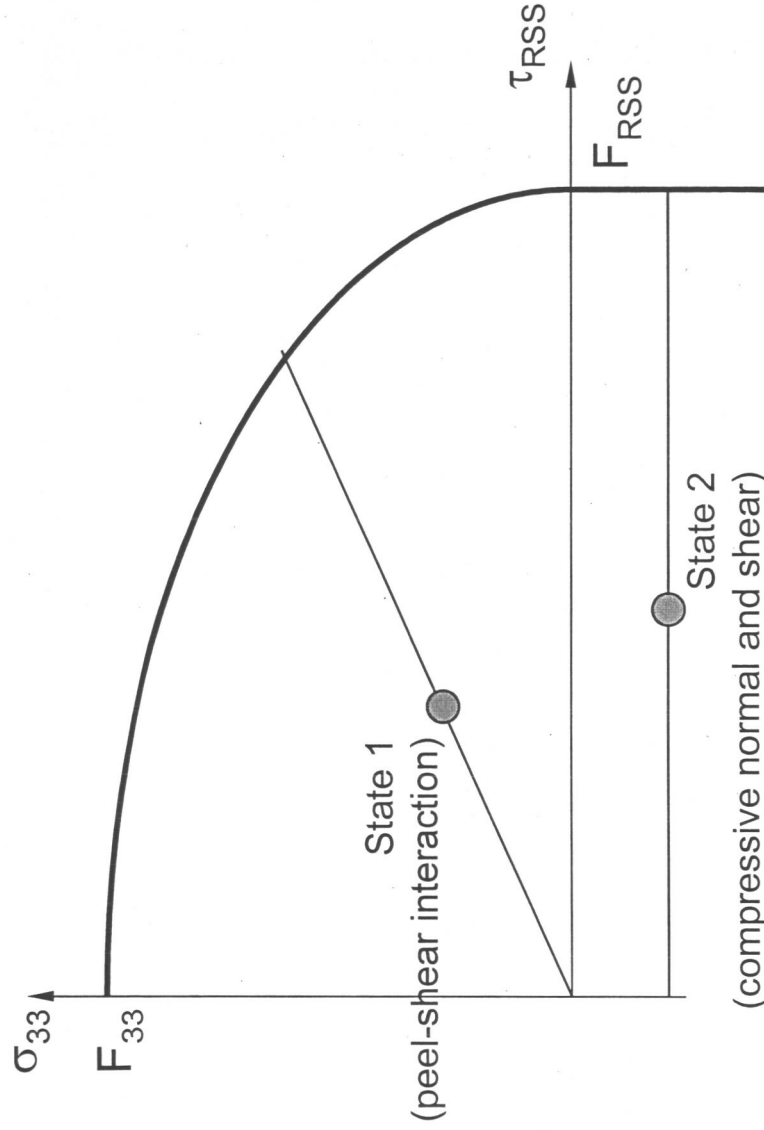



Bonded Joint Analysis Correlation - Procedure



1. Coupon Analysis & Design
(Match Flight Joint Critical Stresses)

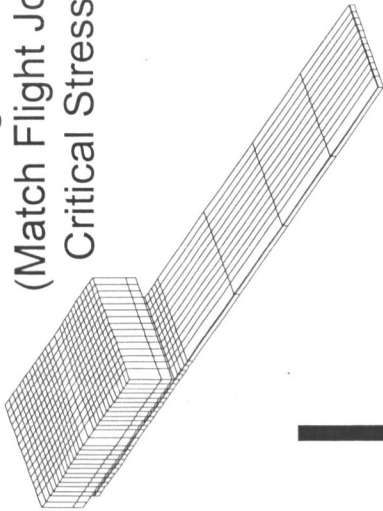

5. Flight Joint Analysis

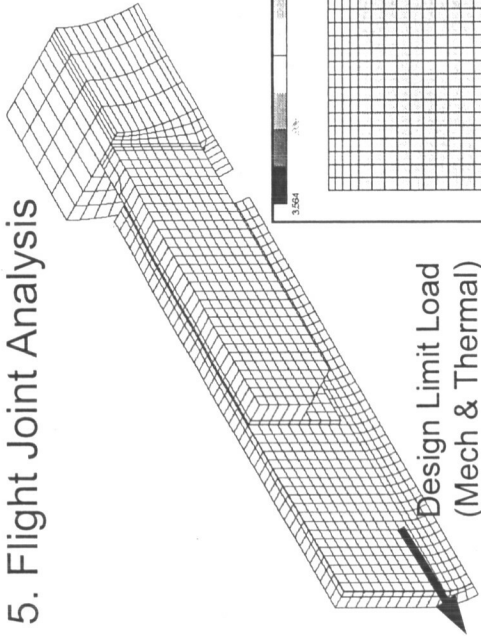

Design Limit Load
(Mech & Thermal)

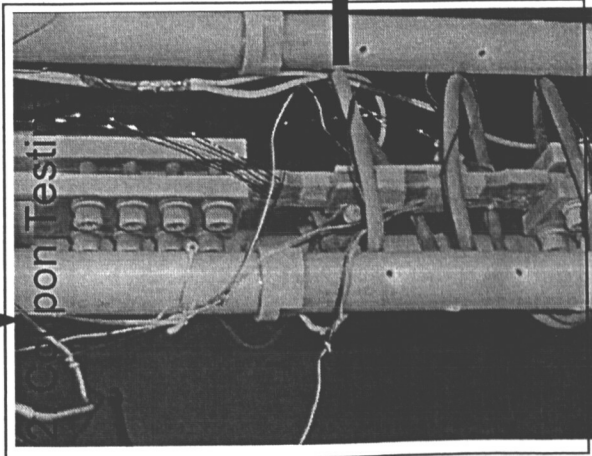
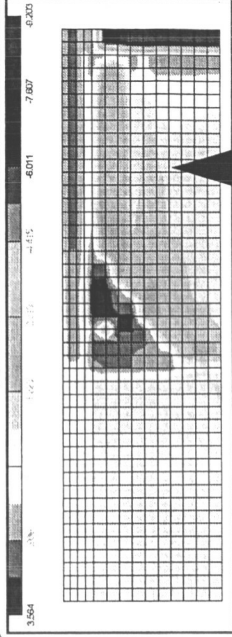
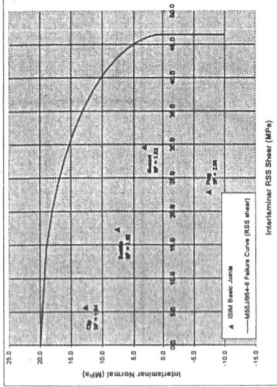

3. Test Coupon Analysis

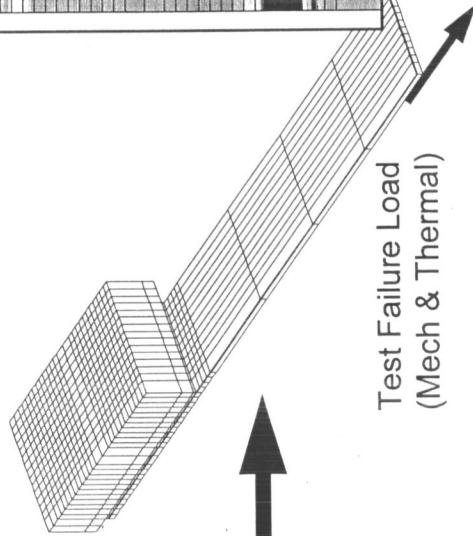

Test Failure Load
(Mech & Thermal)

4. Failure Curve

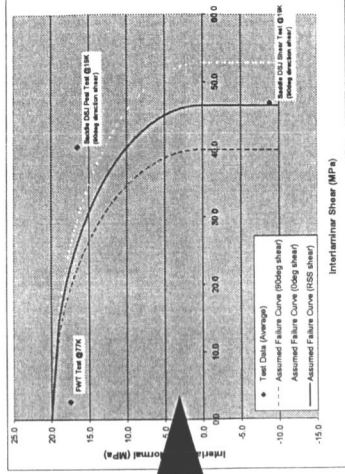



Basic Plug Joint Detailed Stress Analysis

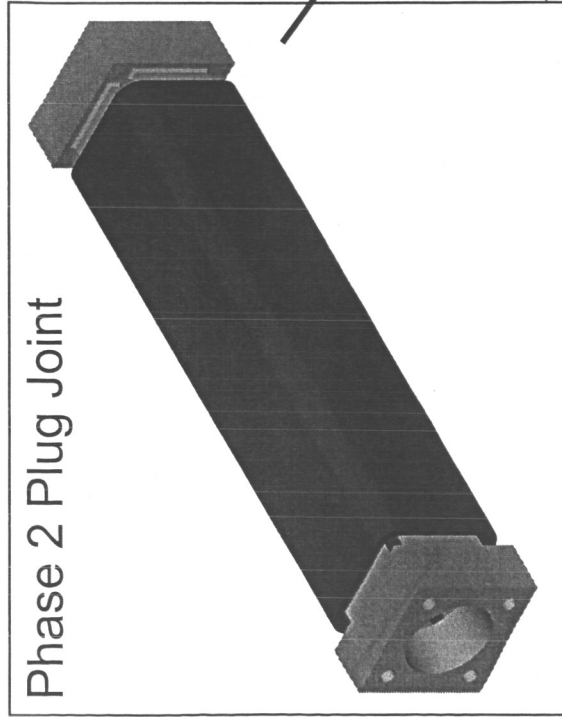

Phase 2 Plug Joint

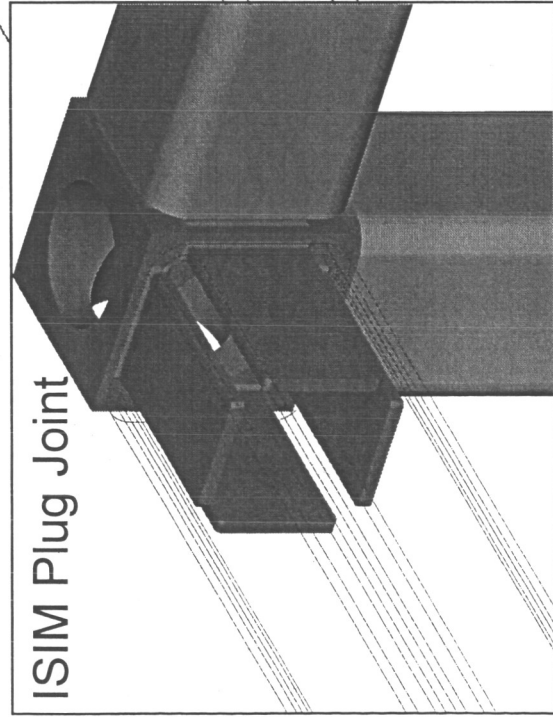

ISIM Plug Joint

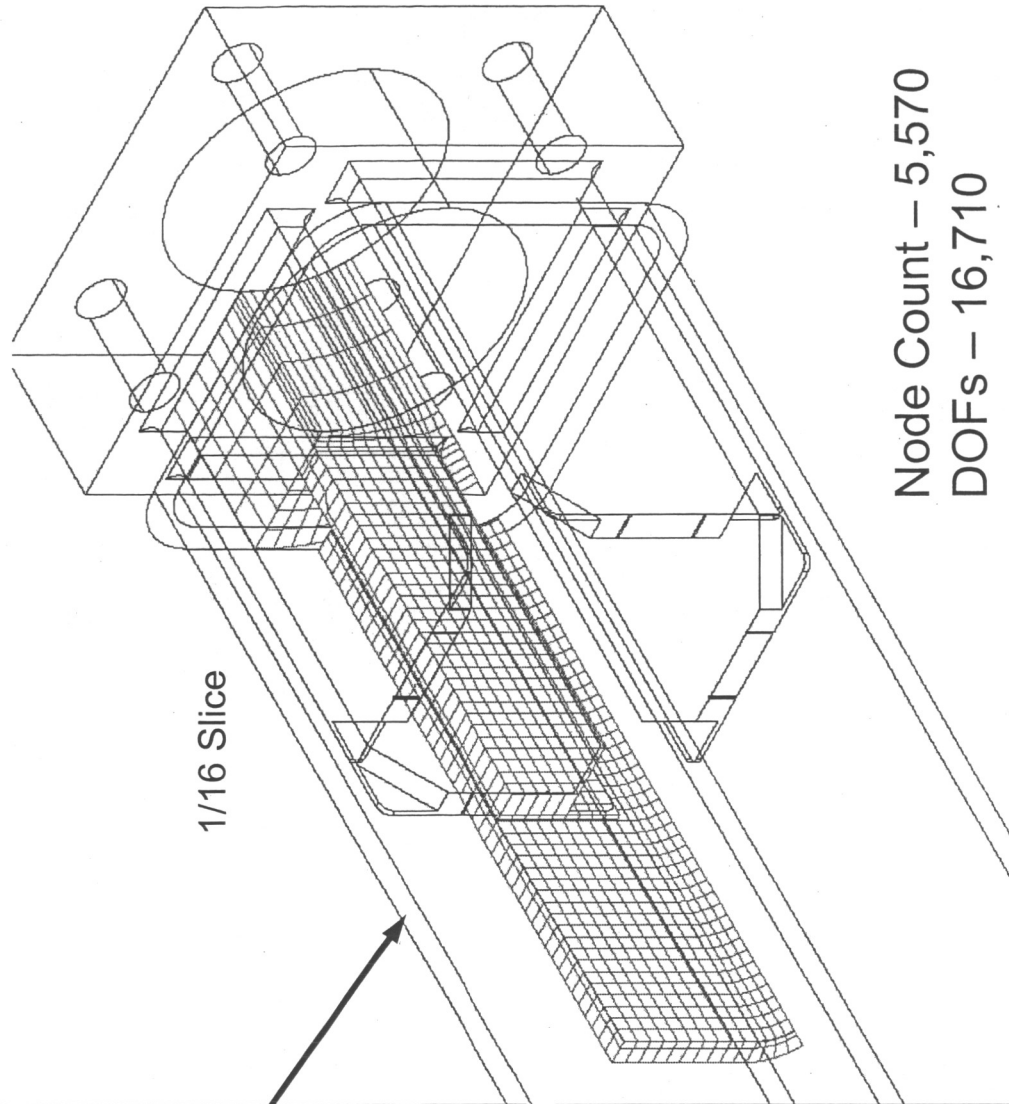

1/16 Slice

Node Count – 5,570
DOFs – 16,710



Basic Plug Joint - FEM

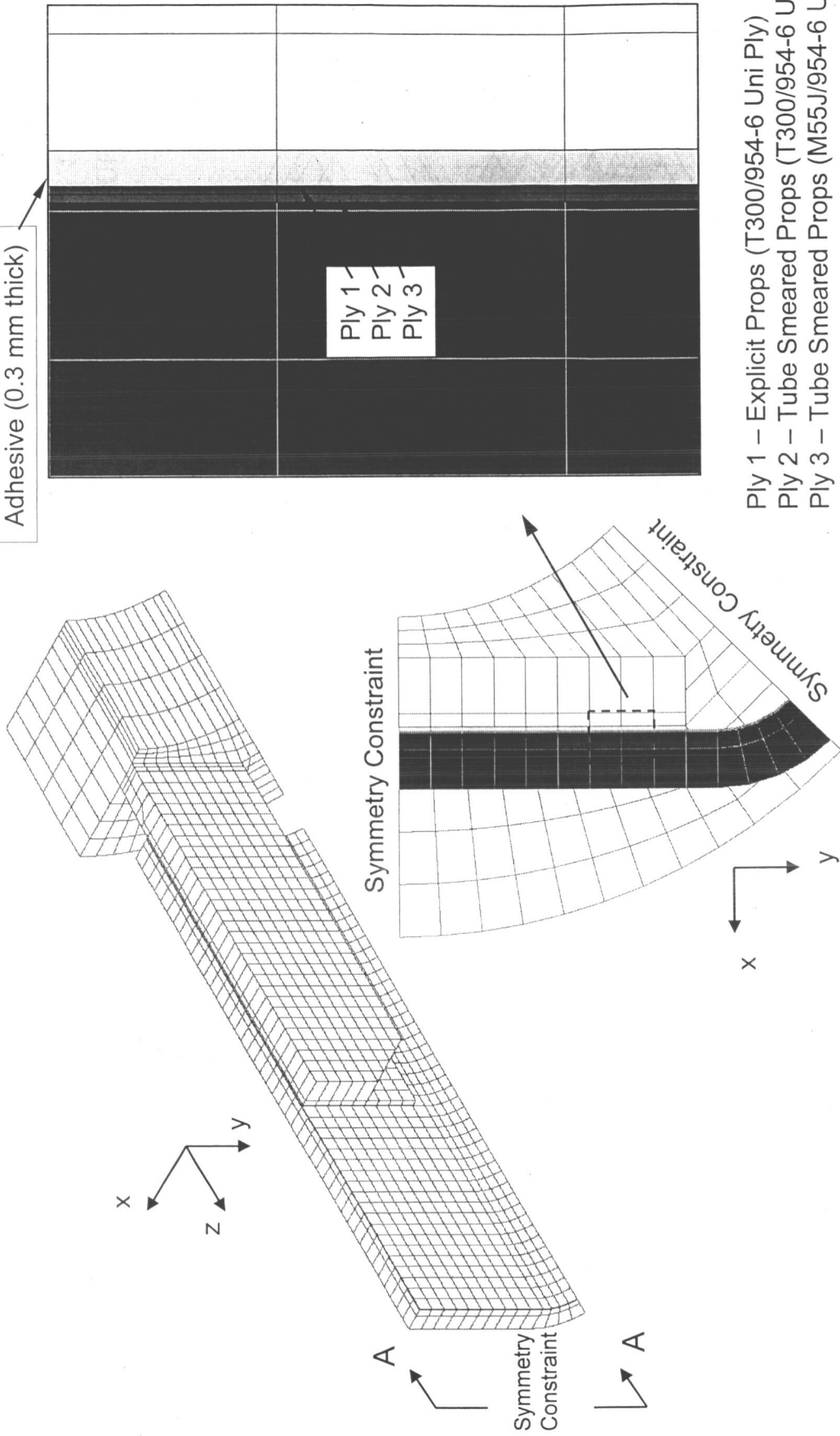

- Ply 1 – Explicit Props (T300/954-6 Uni Ply)
- Ply 2 – Tube Smearred Props (T300/954-6 Uni Ply)
- Ply 3 – Tube Smearred Props (M55J/954-6 Uni Ply)

View A-A



Basic Plug Joint - Applied Loads



Load Case	Type	ΔT (K)	Fz (N)	Remarks
1	Thermal	-271	0	RT to cold survival temperature (22K)
2	Thermal & I/F & 1g	-271	4513	Thermal plus worst case tension (I/F & 1g)
3	Thermal & I/F & 1g	-271	-9096	and worst case compression (I/F & 1g)
4	Launch	0	83200	Absolute max axial load from ISIM beam element model loads run (includes additional effective axial load due to moment load)

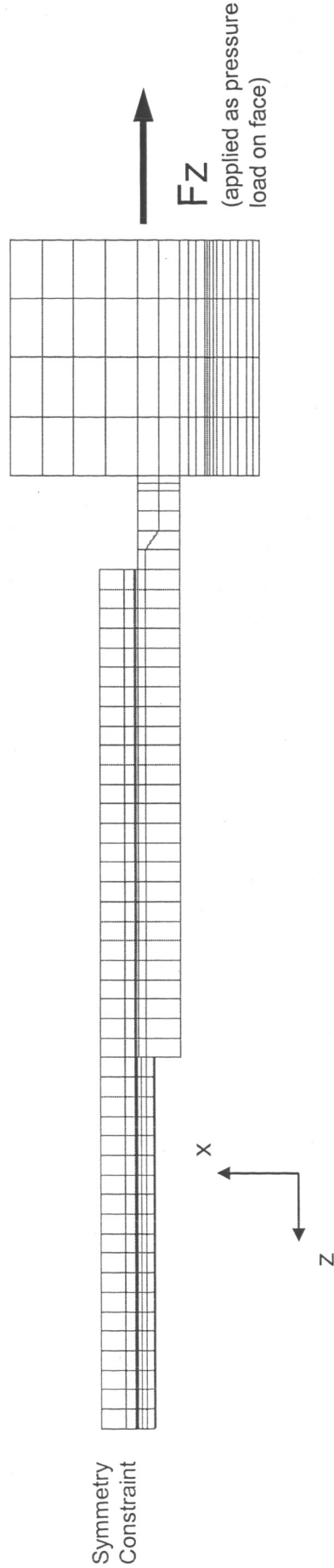



Basic Plug Joint - Margin Summary

Load Case	Failure Mode		Allowable (MPa)	Abs Max (MPa)	MS	Comments
Thermal & Mechanical (-271K + I/F + 1g)	Ply-1 (T300)	σ - τ interlaminar			+ 0.40	
	Ply-3 (M55J)	σ - τ interlaminar			+ 0.32	
	Invar (Blade)	VM yield	275	115	+ 0.91	assume strength properties at cryo to equal properties at room temperature
		VM ultimate	414	115	+ 1.57	
Launch	Ply-1 (T300)	σ - τ interlaminar			+ 0.92	
		s11	1380	162	+ 3.73	max corner stress. allowables are based on explicit props.
		s22	81	12.4	+ 2.63	
	Ply-3 (M55J)	σ - τ interlaminar			+ 0.38	
		s11	439	157	+ 0.55	max corner stress. allowables are based on tube smeared props.
	Tube	s22	241	42	+ 2.19	
		VM yield	275	167	+ 0.32	max corner stress in blade, localize stress raisers at blade/hub interface not included
	Invar (Blade)	VM ultimate	414	167	+ 0.77	



Basic Plug Joint



Ply 3 Interlaminar Stress Plots – Thermal & I/F

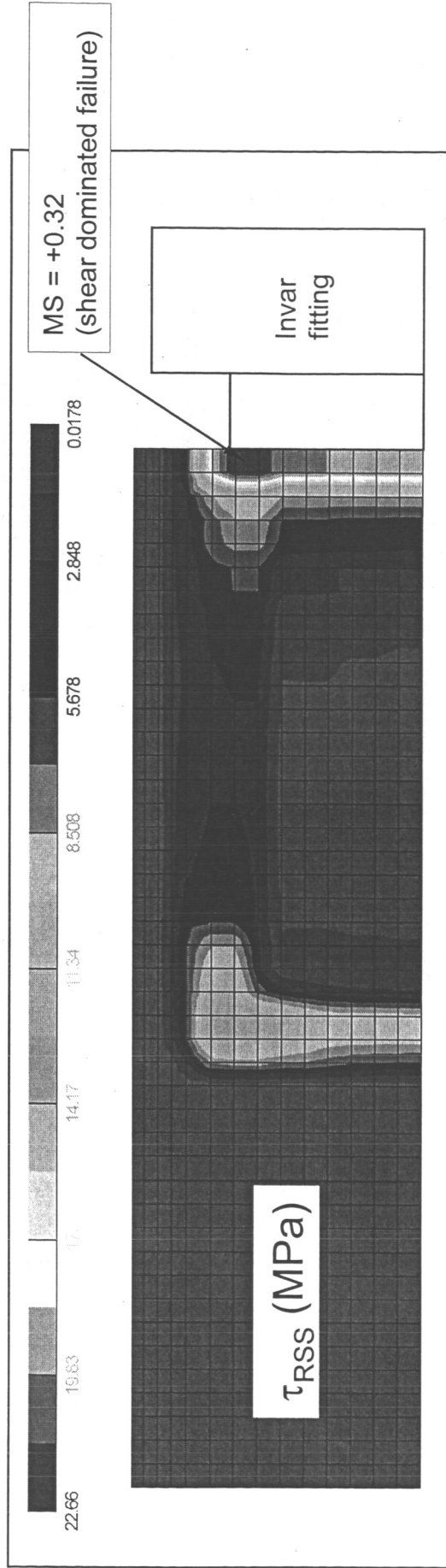
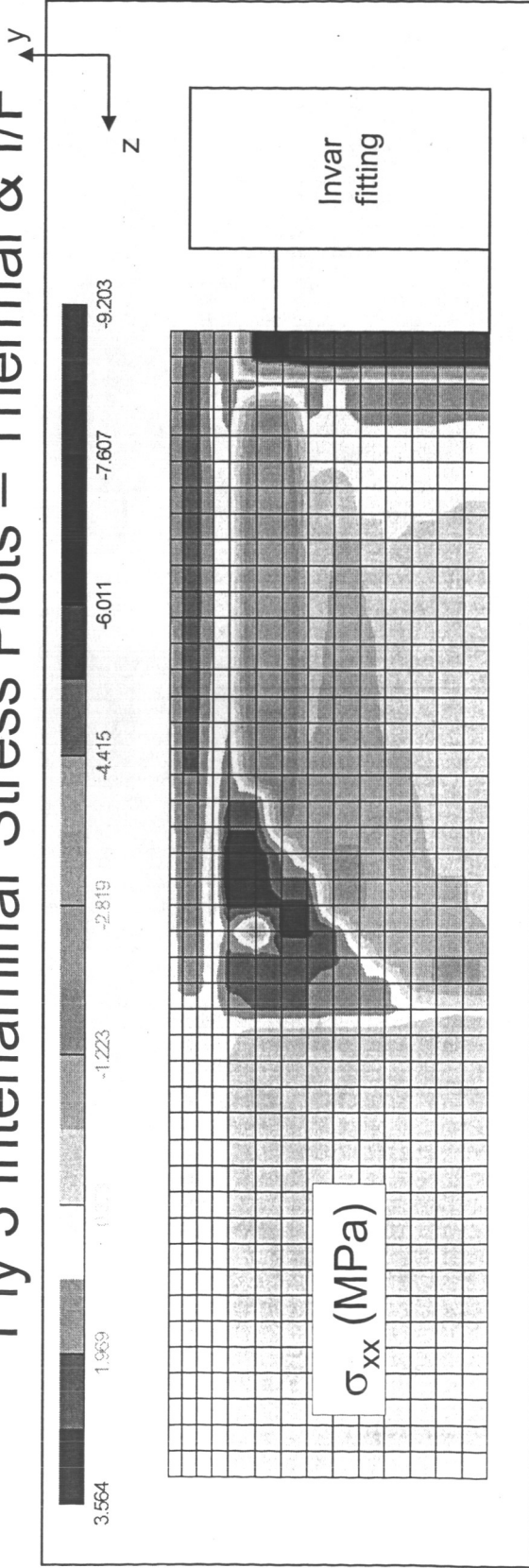



SF and Failure Curve – Basic Joint Assemblies

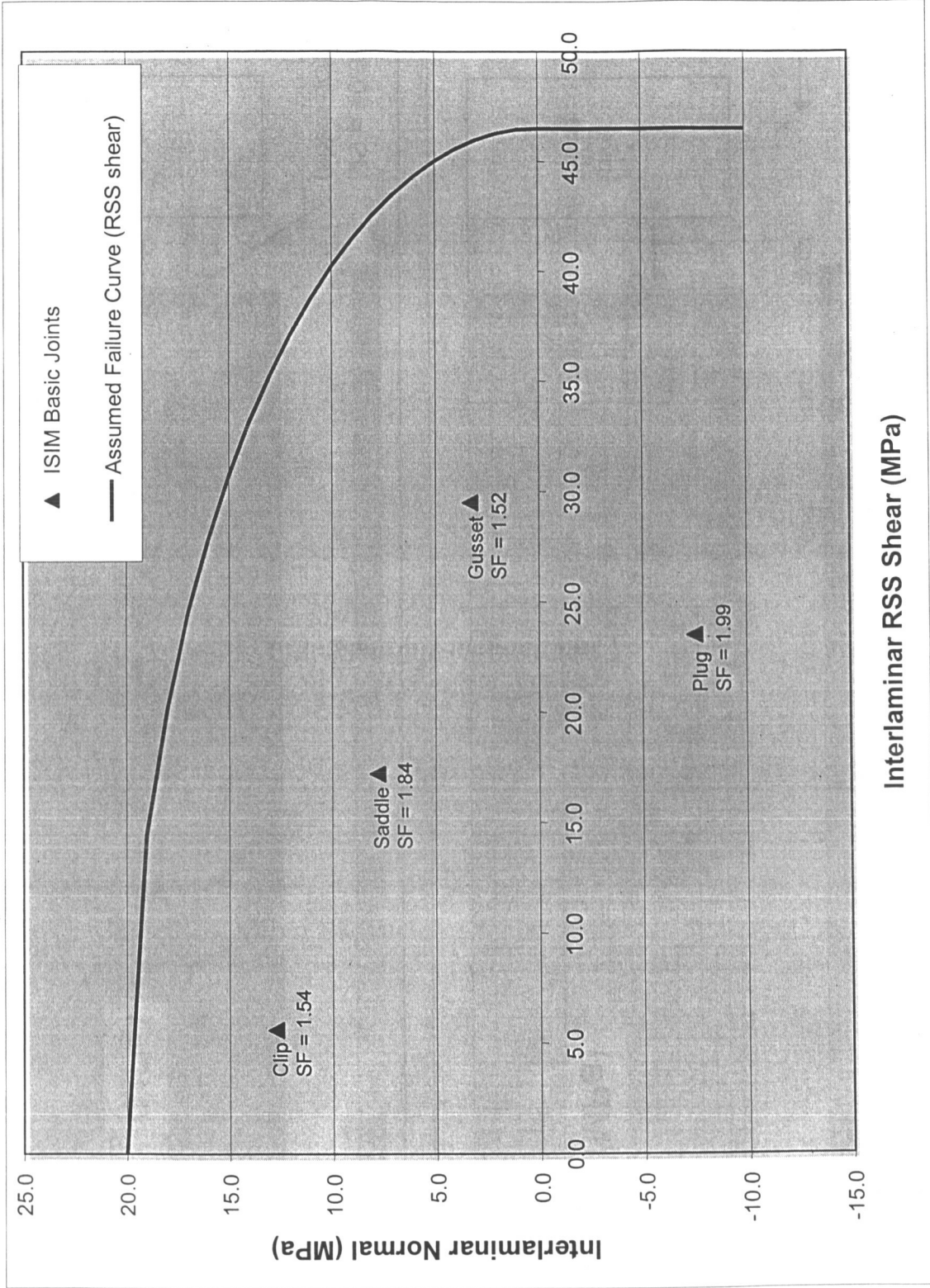



DSJ Test Data and Estimated Failure Curve

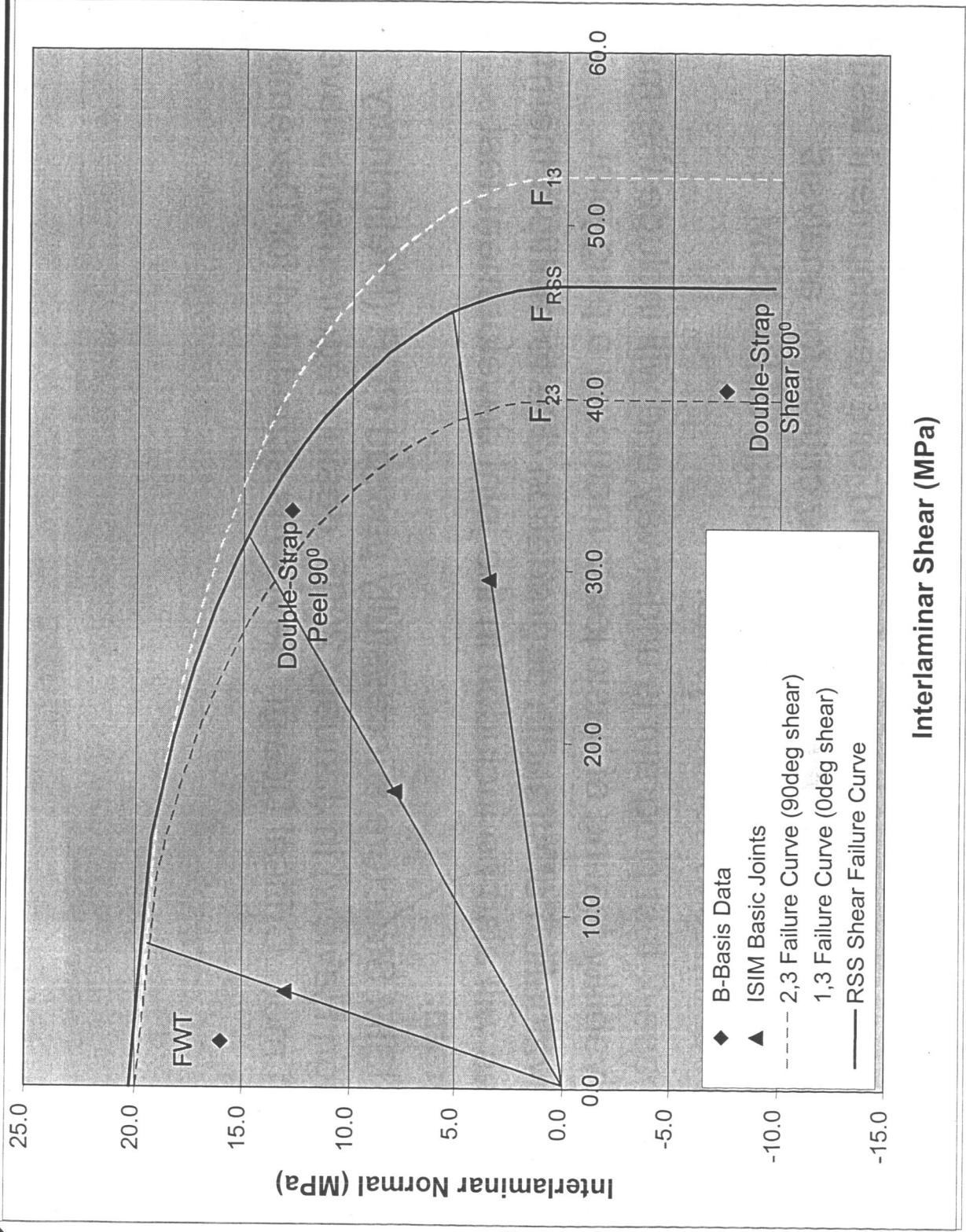

Interlaminar Shear (MPa)



Remarks and Conclusions



- Material characterization testing and joint development testing are in progress. Test results will be critical for analysis correlation and the final design/analysis of the ISIM metal/composite bonded joints.
- A Phase-2 test program is underway and will include thermal survivability testing of basic joints including a plug joint.
- An evaluation of strength degradation due to multiple thermal cycles will also be included in the joint development test program.
- The ISIM Structure successfully passed PDR (Preliminary Design Review) in January 2005, design requirements have been met. Critical Design Review is scheduled for December 2005.