

IN-20
376 505

SHUTTLE LIQUID FLY BACK BOOSTER CONFIGURATION OPTIONS*

T. J. Healy, Jr.
Boeing Reusable Space Systems
Downey, California

ABSTRACT

This paper surveys the basic configuration options available to a Liquid Fly Back Booster (LFBB), integrated with the Space Shuttle system. The background of the development of the LFBB concept is given. The influence of the main booster engine (BME) installations and the fly back engine (FBE) installation on the aerodynamic configurations are also discussed. Limits on the LFBB configuration design space imposed by the existing Shuttle flight and ground elements are also described. The objective of the paper is to put the constraints and design space for an LFBB in perspective. The object of the work is to define LFBB configurations that significantly improve safety, operability, reliability and performance of the Shuttle system and dramatically lower operations costs.

INTRODUCTION

The Liquid Fly Back Booster (LFBB) is a proposed upgrade to the Space Shuttle System which replaces the existing water recoverable, refurbished solid rocket boosters with one or two new fully reusable liquid rocket boosters (Figure 1). The goal of the LFBB program is to increase safety, reliability, performance, and operability, while significantly decreasing operations costs. These LFBB's launch vertically with the Shuttle, but fly back to the launch site, land on a runway and are returned to flight, very similar to a large aircraft (Figure 2).

BACKGROUND OF THE LFBB CONCEPT

The concept of a recoverable liquid rocket booster has been around for many years, predating the Space Shuttle program. Wernher von Braun caught the public's imagination with his concept for a three stage fully reusable launch system¹ which was popularized in *Colliers Magazine* in 1952. In this concept, the first two stages were recovered on parachutes, and the third was a manned winged orbital space plane. All the early Space Shuttle concepts in the late 1960's through the summer of 1971 were fully reusable with fly back liquid rocket boosters^{2, 3} which were piloted. These fully reusable boosters and the two stage fully reusable Space Shuttle concepts were eliminated from the program primarily due to development cost reasons, and a two stage partially reusable system adopted.⁴ The current Shuttle uses two Redesigned Solid Rocket Motors (RSRM), which are recovered by parachute and retrieved by ship. They are completely refurbished for subsequent reuse. The Shuttle also uses an expendable external tank (ET) for second stage propellant for the Orbiter. The Orbiter itself is the only truly reusable element in the system.

However, for safety, performance and operational cost reasons, there has been a continued interest in replacing the Shuttle's solid rocket boosters with liquid rocket boosters, usually reusable concepts. The Shuttle Growth

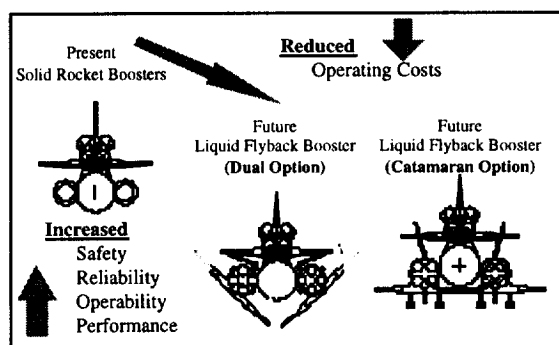

Figure 1. A possible Shuttle upgrade - Liquid Fly Back Boosters

Distribution Statement: Approved for public release; distribution is unlimited.

* This unclassified work was performed under NASA Contract NAS8-97272 as part of NASA's Shuttle Upgrades Feasibility Investigation of Liquid Fly Back Boosters (LFBB). Presented at July, 1998 JANNAF JPM.

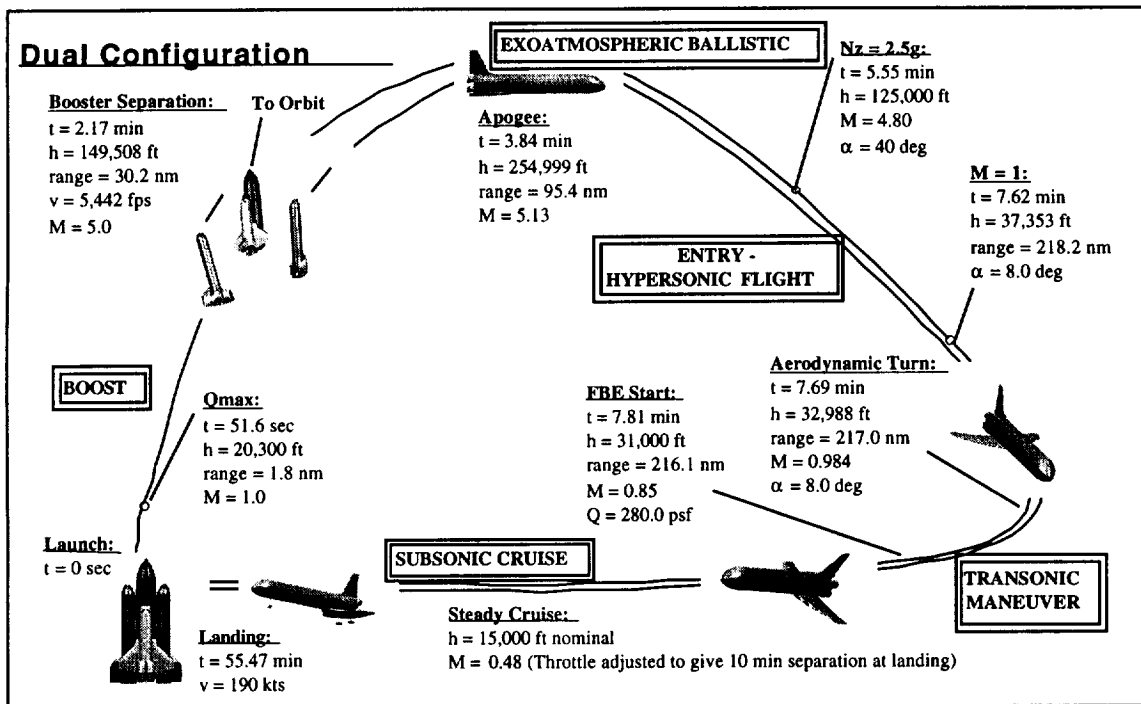

Figure 2. The LFBB sees five different flight regimes

Study, sponsored by Marshall Space Flight Center (MSFC) and conducted by Rockwell in the mid-1970's was typical.⁵ This study examined a wide range of water recoverable and fly back land recoverable, reusable boosters, finally electing a parachute/water recoverable liquid booster, in order to limit the estimated development costs, at the expense of operations.

After the Challenger disaster, interest was rekindled in liquid rocket boosters to replace the solids. A major effort was conducted by MSFC with contracts to Martin Marietta (NAS8-37136) and General Dynamics (NAS8-37137), supported by the Kennedy Space Center with a contract to Lockheed (NAS10-11475). The effort was concentrated in the 1987-1989 time period, with some tasks on-going to 1991. The focus was on liquid rocket boosters that could easily replace the solid boosters; and while recovery was studied, the selected baselines were expendable.^{6,7}

Meanwhile, interest in fully reusable liquid boosters continued to build as part of a thrust for continued Shuttle evolution and improvement.^{8,9} NASA conducted an extensive in-house Access-To-Space Review in 1993, out of which have grown several important thrusts, including the Shuttle Upgrade program and the Reusable Launch Vehicle program. The Access-To-Space team, studying Shuttle evolution, recommended a liquid fly back booster as a key Shuttle improvement.¹⁰ This recommendation resulted in NASA embarking on a major in-house study, the Liquid Fly Back Booster Pre-Phase A Assessment, completed in September 1994.

The Liquid Fly Back Booster Pre-Phase A Assessment^{11,12} concluded that a liquid fly back booster (LFBB) is the only cost effective replacement for the solid rocket boosters from a life cycle cost standpoint. The primary benefits from the proposed LFBB are enhanced safety, operability, reliability and performance, and a significant reduction of operational costs. This renewed interest in LFBB's and a number of concepts were investigated in parallel with or subsequent to the NASA efforts (Figure 3). NASA placed the LFBB into the Shuttle Upgrades program as a Phase IV improvement, but follow-up effort was postponed. Perceived high development cost was an issue. In 1996, Rockwell (now Boeing) conceived a catamaran configuration that promised affordable development costs. This sparked renewed interest in getting detailed LFBB feasibility data to support Shuttle service life decisions

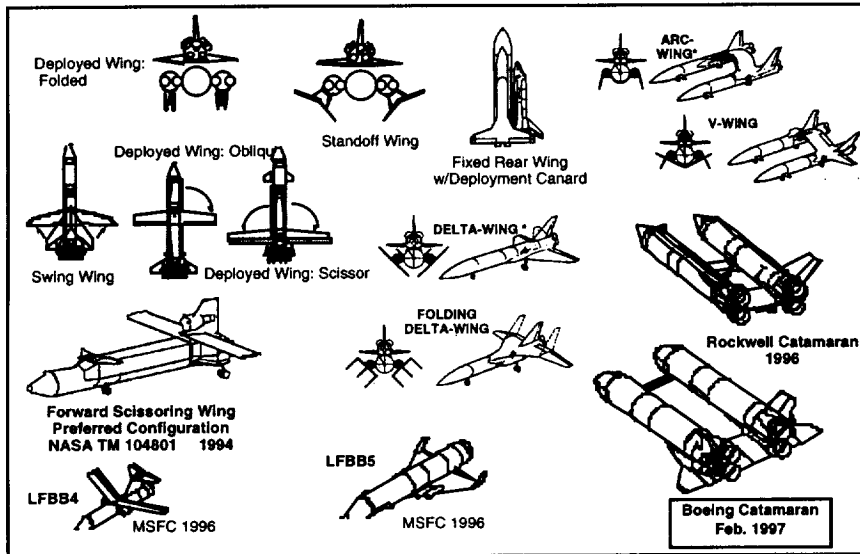

Figure 3. Many LFBF concepts have been studied

and resulted in NASA establishing a study effort in February 1997 to conduct feasibility studies of the LFBF. This LFBF effort is under the direction of Johnson Space Center (JSC) who controls the system integration effort. Supporting JSC is MSFC who leads the LFBF vehicle development and has awarded study contracts to Boeing and Lockheed-Martin. KSC support the effort focusing on operations and launch facilities. As of the spring of 1998, the results of this

effort are: (1) LFBF concept is viable--three configuration options identified; (2) no technology breakthroughs are required; and (3) three affordable main engine candidates are available.¹³

LFBF GOALS AND REQUIREMENTS

The LFBF responds to the overall objectives of the Shuttle Upgrade program which are to fly safely, ensure mission supportability, meet the manifest, and reduce cost. Applied to the LFBF, these become the goal areas, shown in Figure 4. These requirements affect all aspects of the LFBF design, but several are key in driving the LFBF aerodynamic and propulsion system configurations. Many of these interrelationships drive to conflicting optimums, thus opening the way for tradeoffs and design compromise.

CONFIGURATION TRADES

The configuration trades are performed within a framework of geometry, system and configuration constraints that limit the trade space. Major constraints are that the LFBF:

- Is fully reusable, land recoverable at the launch site--previous studies show this is required to meet operations cost goals.
- Uses catamaran (twin fuselage) or dual boosters, using ET/SRB attach locations--single and triple or greater boosters create major ET redesign and other integration issues (Figure 5).
- Uses liquid oxygen/RP-1 (or kerosene) propellants--use of liquid hydrogen makes the LFBF too large to integrate with the Orbiter or KSC.
- Meets KSC facilities constraints
 - Vehicle Assembly Building (VAB) door width (Figure 6)

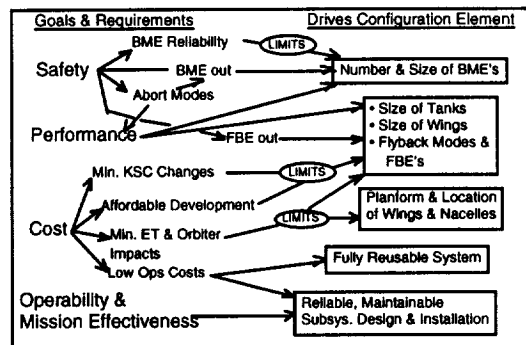

Figure 4. LFBF goals & requirements shape configuration options

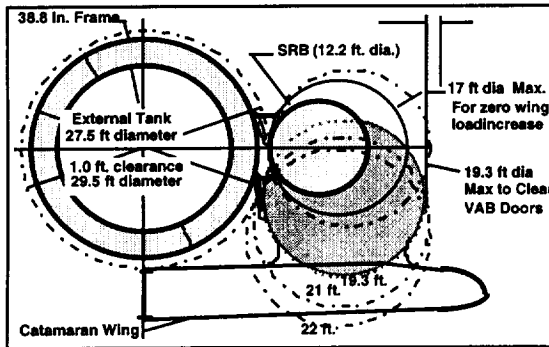

Figure 5. Facilities constraints & air loads limit body diameter & location

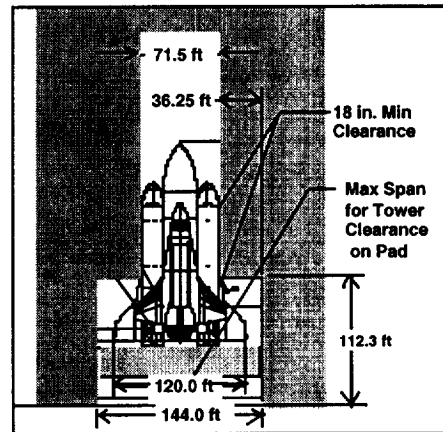

Figure 6. Min. clearance of VAB doors

- Use a Mobile Launch Pad (MLP that can be modified from the existing MLP
- Use existing Tail Service Masts (TSM)
- Clear the launch pad service tower and use existing flame trench (Figure 7)
- Maintain Orbiter and ET position in relation to MLP as it presently exists.

Four major trades were the primary configuration shapers: (1) number of Booster Main Engines (BME), (2) abort modes, (3) fly back modes and engine installation, and (4) aerodynamic configuration. These trades are interactive. These trades are complete but effort continues optimizing the aerodynamic configuration and engine installation. A summary of the results is:

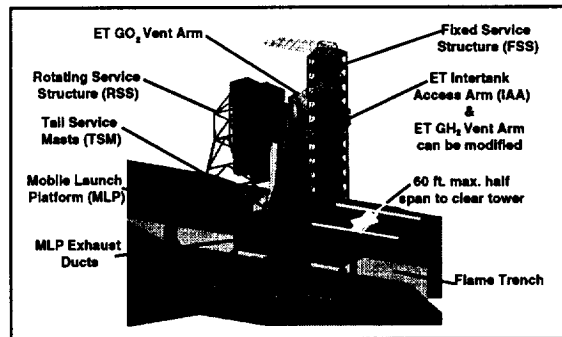

Figure 7. Key launch pad constraints

- Number of Engines
- Abort Modes
- Fly Back Mode
- Aerodynamic Configuration (Boeing Specific)

- Eight BME's, four per side
- Design to provide Transatlantic landing from liftoff (eliminates RTLS)
- Subsonic cruise, using low by-pass turbofan fly back engines (FBE)
- Catamaran, nose mounted FBE, low mounted fixed 45° leading edge sweep outer wing panels, 120 foot span
- Or: Dual boosters, under fuselage FBE Nacelle, low mounted fixed 35° i.e. sweep aft mounted wings, span mounted as 39° clock angle

NUMBER OF ENGINES

The scope of this trade was to primarily determine the optimal number of “generic” LOX/RP engines for the LFBB, and secondarily to match the resulting engine requirements with potential real engines. Our approach was to establish a generic “rubber” engine (Table 1) and to examine the sizing and cost effects of 2 through 6 BME per side. Loss of vehicle (LOV) estimates were made by coupling existing engine failure data to project expected failure rates and simulating the mission in a Monte Carlo analysis which traced each engine through 500,000 flights. A key result was the need to minimize catastrophic BME failures, not necessarily all failures, to ensure low LOV. This puts added emphasis behind the engine health

Table 1. Generic BME specs (vacuum)

Thrust Range	400K lbs to 1.8M lbs
T/W	≥ 95
Isp	340
Cycle	Oxidizer, rich, full flow

management efforts at each of the engine suppliers. The results (Figure 8) show that four BME's per side is the preferred configuration.

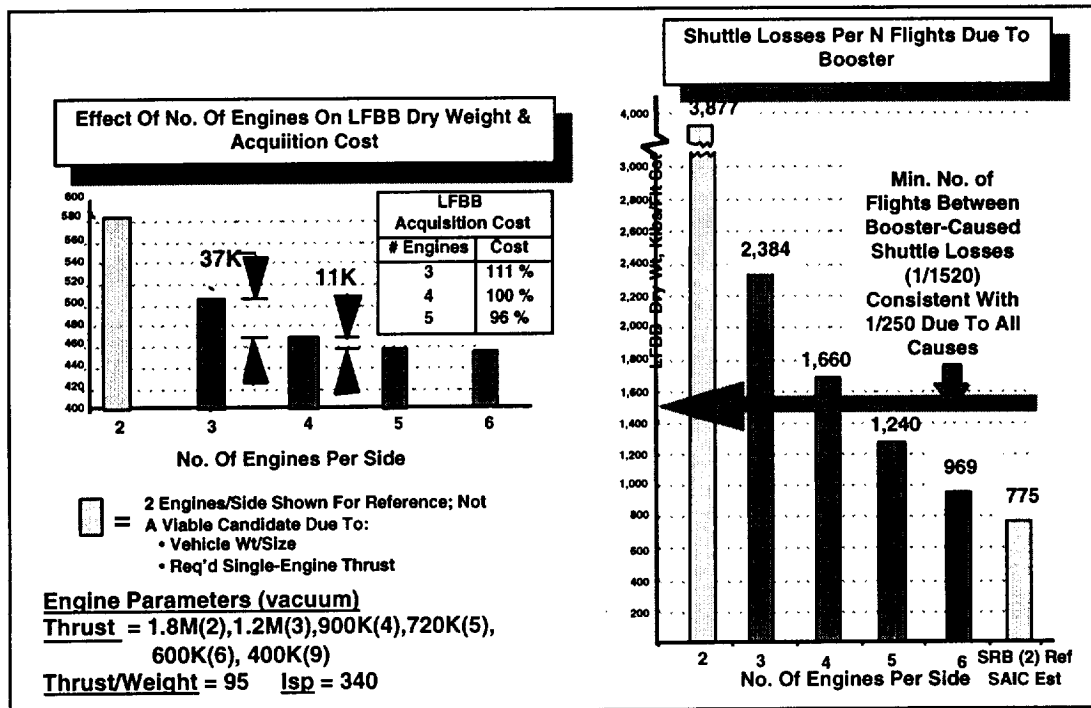

Figure 8. Four BME per side is minimum size & cost that meets reliability goal

ABORT MODES

After selecting the number of engines, the LFBB system was examined to determine the effects of the choice of abort mode on vehicle weight, size, cost and integration constraints. Our approach was to resize the vehicle analytically to fly each of the four options: (1)Abort to Orbit (ATO) from the pad;(2)Trans Atlantic Landing (TAL) from the pad to ATO; (3)Return to Launch Site (RTLS) + ATO; and (4)RTLS + TAL + ATO. The results show that ATO from the pad drives a larger, more expensive LFBB with integration issues and limited BME options. This mode was rejected. Retaining all the Shuttle abort modes gives the smallest, least expensive vehicle, but does not contribute to LFBB goals of increased safety or mission effectiveness. These results are shown on Figure 9. The decision was made to baseline TAL from the pad, which retains the option to fly RTLS if desired. Figure 10 shows the exposure to aborts for a standard Shuttle Space Station rendezvous mission and two LFBB options flying the same mission. On the option eliminating TAL, TAL is still available after about 1-1/2 minutes, while on the option eliminating RTLS, both RTLS and TAL options exist from the pad. In both cases, ATO is available after about 3-1/2 minutes, which is about a minute earlier than on the standard Shuttle.

FLY BACK MODES AND ENGINE INSTALLATION

An important influence on LFBB design is the selection of the fly back mode, as all provisions for fly back have to be carried through ascent as dead weight. Three basic options are available and were evaluated:

- Glide back - no propulsion
- Boost-glide - using rocket engines
- Fly back - subsonic cruise using jet engines

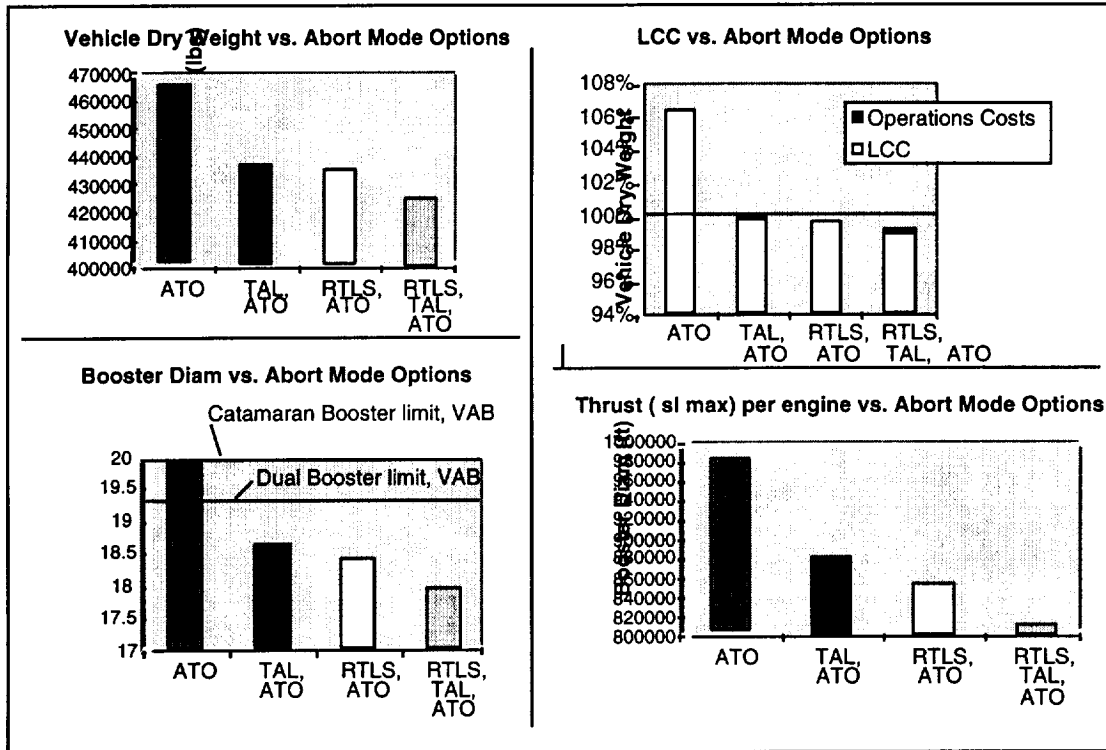

Figure 9. TAL/ATO selected - Increased safety & mission effectiveness for minimal cost increase

These options were evaluated for effects on LFBB weight and size, costs and loss of vehicle. The staging initial conditions are essentially fixed by the Shuttle mission requirements and are shown in Table 2. The results are that glide back is not feasible for the LFBB (Figure 11), and boost-glide fuel requirements are greater than fly back fuel plus fly back engines and installation provisions (Figure 12). The boost glide mode also introduces operational issues, such as the lack of loiter and flight separation capability for the dual LFBB configurations. There is also the issue of propellant acquisition during entry and BME restart. Therefore, the fly back mode was selected as baseline (Figure 13).

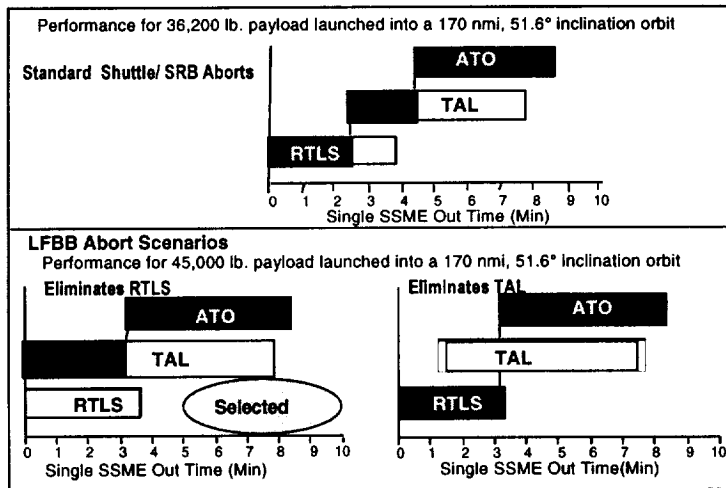

Figure 10. Abort scenarios for single SSME out. LFBB offers greater safety & flexibility.

The next step was to pick preferred engine size, types and numbers. Our approach was to identify thrust requirements, identify candidates, determine installation requirements and engine out requirements, and finally select

Table 2. Staging conditions for fly back trades

Weight at staging, lbs	286,148
Weight at air turbine (or rocket) start, lbs	275,173
Staging Conditions	
Time, sec	166.40
Altitude, ft	192,186
Range	55.55
Velocity, relative, ft/sec	6727.1
Mach no.	6.450

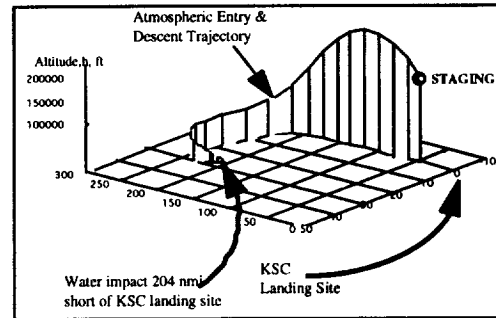

Figure 11. Glide back is not feasible for return to KSC

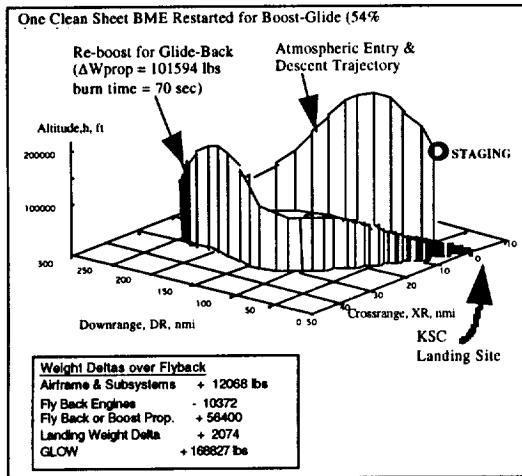

Figure 12. Boost-glide requires 101,600 lbs of propellant to return to KSC

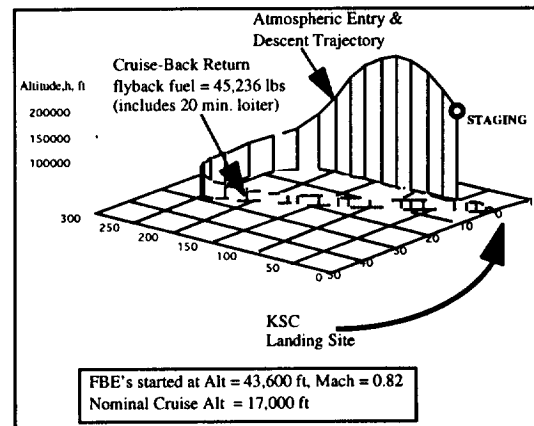

Figure 13. Cruise with 20-min. loiter requires 45,200 lbs fuel for return to KSC

preferred installations. Table 6 shows the representative engines that were examined for potential installation on the LFBB.

Table 3. Fly back engine installation options

Engine Type & No.	1 x GE90	2 x CFG-80	4 x CFM-56	4 x F119 or F118 or F100-PW-229
Installation Type				
External POD or Nacelle	N, M	N, M	N, M, A	N, M, A
Semi-Buried (Slipper)	M	N	N, M	N, M
Internal Deployable Inlets	N	N	N	N, M
Deployable Engines				M
N = Nose		M = Midbody		A = Aft

The large commercial high bypass ratio turbofans were eliminated for several reasons. No truly viable installation was developed; high thrust lapse rates with altitude drove up the installed sea level thrust requirements; and the LFBB was not flyable with a jet engine out. It is recommended that single engine out is required for the LFBB, because the loss rates became excessive if all engines were required for flight. Table 4 gives LOV data for four engine installations, typical of the low bypass military turbofans evaluated.

A number of installations for low bypass ratio military jet engines were evaluated for the LFBB, and several feasible installations were created for the nose, midbody and under the fuselage. Several of these are illustrated in Figure 14. The dual boosters use four engines mounted in nacelles, with acceptable configurations being in pairs on each side of the fuselage, or four side by side in under fuselage nacelles. The nacelle location is constrained by the ET, the VAB door width, and ascent flow effects on the orbiter. Figure 15 illustrates the selected four-in-the nose installation for the catamaran LFBB, which uses a total of eight FBE's, four in each nose. Evaluation of the FBE continues with F100, F101, F110, F118 and F119 variants being candidates.

Table 4. Comparison of LFBB loss of vehicle rates with and without FBE out capability

R per Jet Engine Start & Operate	Engine R 3 of 4	Vehicle R (All)	LOV Rate 3 of 4 1 per "n"	Engine R 3 of 3	Vehicle R (All)	LOV Rate 3 of 3 1 per "n"
0.995	0.9998510	0.9995336	2144	0.9850746	0.9847620	66
0.996	0.9999045	0.9995871	2422	0.9880952	0.9877816	82
0.997	0.9999462	0.9996288	2694	0.9909910	0.9906765	107
0.998	0.9999761	0.9996587	2930	0.9940120	0.9936965	159
0.999	0.9999940	0.9996766	3092	0.9970060	0.9966895	302
	FBE Out			No FBE Out		

In general, the FBE's want to be located away from the BME's to reduce the dynamic environment. The FBE's need to be protected from the free airstream and thermal effects through ascent and entry. But, the actual location on the LFBB is governed by LFBB center of gravity location requirements and by ascent airloads requirements. The nacelles can't be positioned so as to increase landing loads on the Orbiter wing. The buried nose installation is a low duct loss, well protected installation, ideal for configurations with a wing positioned for a more forward center of gravity.

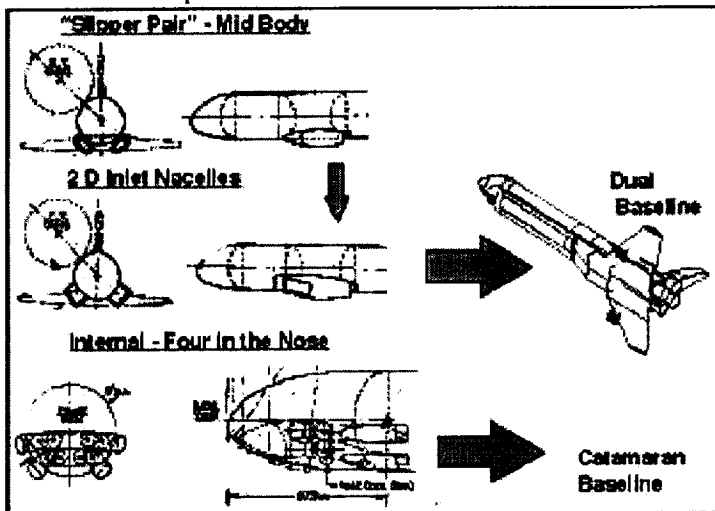

Figure 14. Low bypass turbofan installations

AERODYNAMIC CONFIGURATION

- The aerodynamic challenges of an LFBB include:
- Facility access/geometry constraints at KSC
 - Shuttle ascent loads and trajectory constraints
 - Body/body interferences
 - Hypersonic/supersonic/subsonic aerodynamics (Fly Back)
 - Aft center of gravity
 - Aerodynamic control effectiveness/flight quality
 - Jet engine adaptiveness

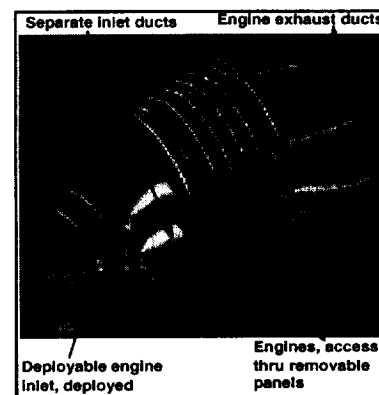

Figure 15. Nose installation

The first task was to select a preferred wing planform looking at the structural/aerodynamic interactions. The objective was to narrow the options between delta, swept, swing and folding wings. A broad range of options was addressed in a series of minitrades, as shown in Figure 16. Trades were first conducted between high and low wings with low being selected due to weight and geometry problems with the landing gear.

Then variations of stowed and swing wings were traded to select the best of this class. Finally the best of the swing wings were traded against the delta wings--a lower aspect ratio with no folds and a higher aspect ratio version with folding wing tips. As shown on Figure 17, the higher aspect ratio delta wing with folding tips was selected as the preferred baseline. Decreases in fly back fuel and downsizing of the LFBB more than made up for the wing fold mechanisms.

The second task was to find an arrangement of wings and bodies that meet both the ascent and fly back requirements. A series of wind tunnel tests were conducted at MSFC on a number of 0.4% scale configurations, as shown in Figure 18, to determine the ascent aerodynamics. It should be noted that for ascent the catamaran is a special case of the dual boosters, with the boosters rotated down to 90°.

The wind tunnel testing in the spring of 1997 provided data showing that the catamaran did not affect Orbiter loads, and in some cases, decreased them (Figure 19). However, as shown in Figure 20, to maintain Orbiter wing loads, the dual LFBB configuration had to be flown at negative angles of attack outside of the certified Orbiter flight envelope. Further testing at the MSFC trisonic tunnel and the Lockheed 20x28 tunnel provided data which indicated that a revised 35° LE sweep wing would reduce Orbiter wing loads to acceptable levels within the flight envelope, as shown on Figure 21. When the dual LFBB was reconfigured with the new planform and rebalanced for fly back, a further series of wind tunnel tests were conducted, this time at the Boeing/St. Louis polysonic tunnel.

The surprising result was that the Orbiter wing bending moments were not reduced and in some cases increased. This wing load phenomena was eventually traced to the relationship of the LFBB wing leading edge and other significant forward protuberances, as engine nacelles, to the Orbiter wing. The dual configuration wing was relocated further aft, the configuration rebalanced, and in February and March of this year, a further series of wing tunnel tests

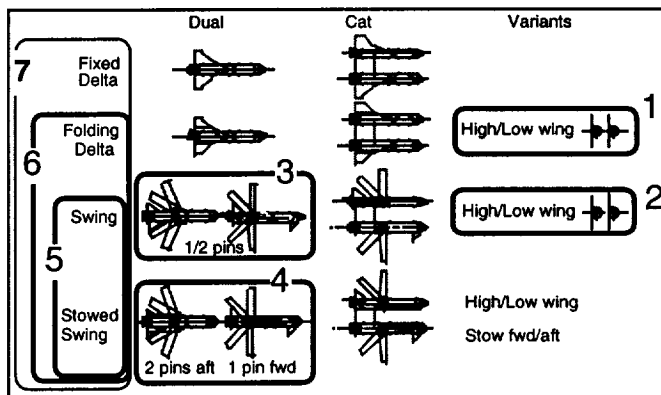

Figure 16. Wing planform trade configurations

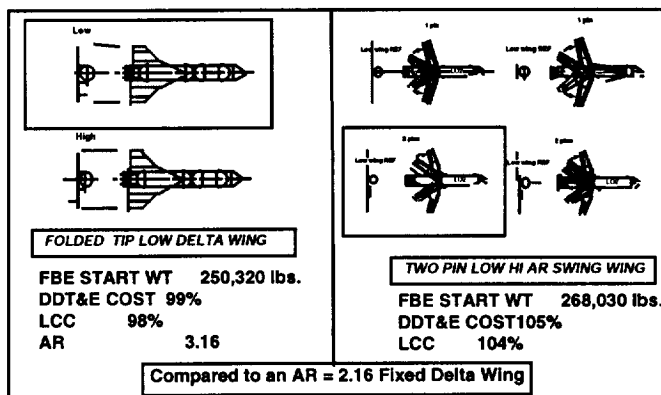

Figure 17. Higher aspect ratio delta wings are less cost & weight than swing wings or low aspect ratio deltas

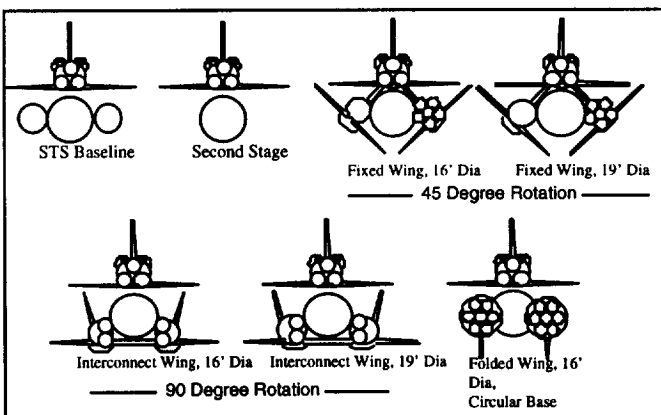

Figure 18. Configurations tested in the MSFC Trisonic Wind Tunnel in the spring of 1997

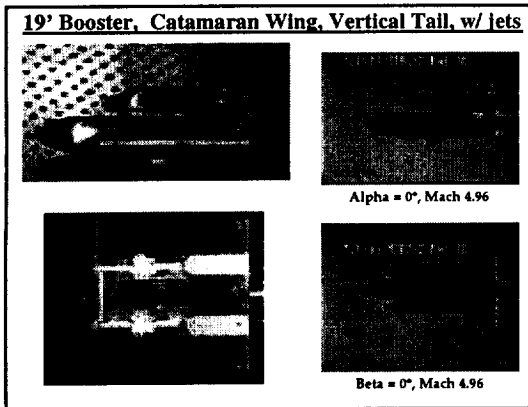

Figure 19. The catamaran met all Shuttle ascent aero requirements

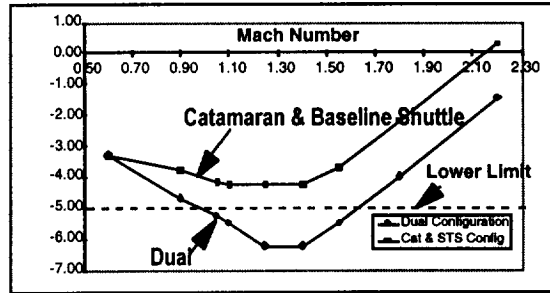

Figure 20. Zero-added wing load angle-of-attack profile for the initial dual configuration exceeded Shuttle angle-of-attack & load limits were conducted at MSCF (Figure 22). These tests confirmed that the Boeing dual with aft mounted 35° LE sweep wing would be within Orbiter limits as shown on Figure 23.

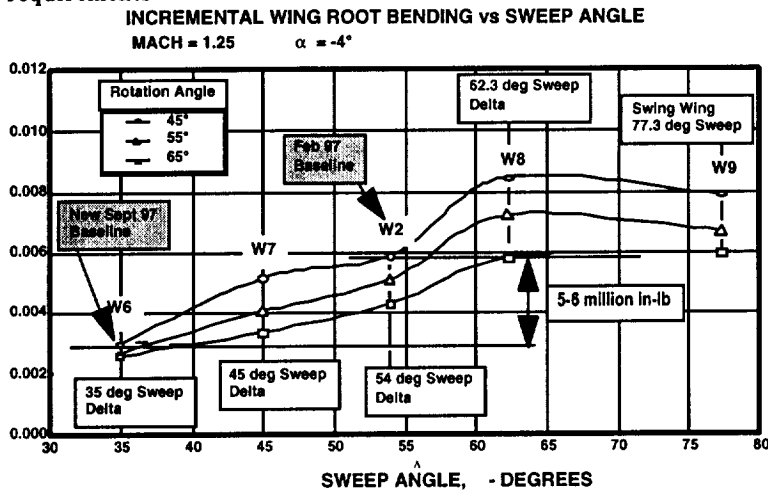

Figure 21. Preliminary results indicate revised wing planforms & booster roll angles reduce Orbiter wing loads about 5-6 million in-lbs.

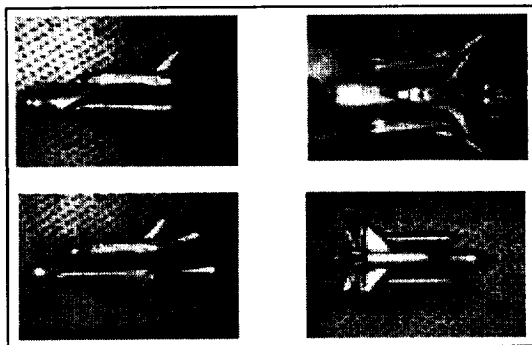

Figure 22. Boeing LFBB wind tunnel models showing wing / nacelle configuration that is within Orbiter wing bending limits

Another, very surprising result of these tests was that an active canard could be deflected during ascent to provide a favorable shock/expansion pattern that would actually lower Orbiter wing bending loads. The 20° deflection required at maximum quill impose very high loads on the canard and its supporting structure, and will introduce significantly larger torsion into the ET. This canard will also introduce large control forces into the Shuttle stack that have to be countered by BME or SSME thrust vector control. The canard may have to be actively controlled during ascent.

The result of these tests is that the catamaran configuration integrates easily with the Orbiter on ascent, keeps the FBE's and BME's widely separated, and has an inherently higher L/D which improves fly back. It is a single airframe which provides some operational advantages, but is a large aircraft. The dual, on the other hand, can meet the system requirements, but is very sensitive to small changes in the ascent configuration. Its advantage lies in the fact that it is a smaller aircraft, and, therefore, easier to initiate into development and perhaps use for alternate applications.

LFBB CONFIGURATIONS

As a result of these trades, analysis and test, two configurations have been identified for further study, and NASA has reported that an LFBB for Shuttle is feasible.

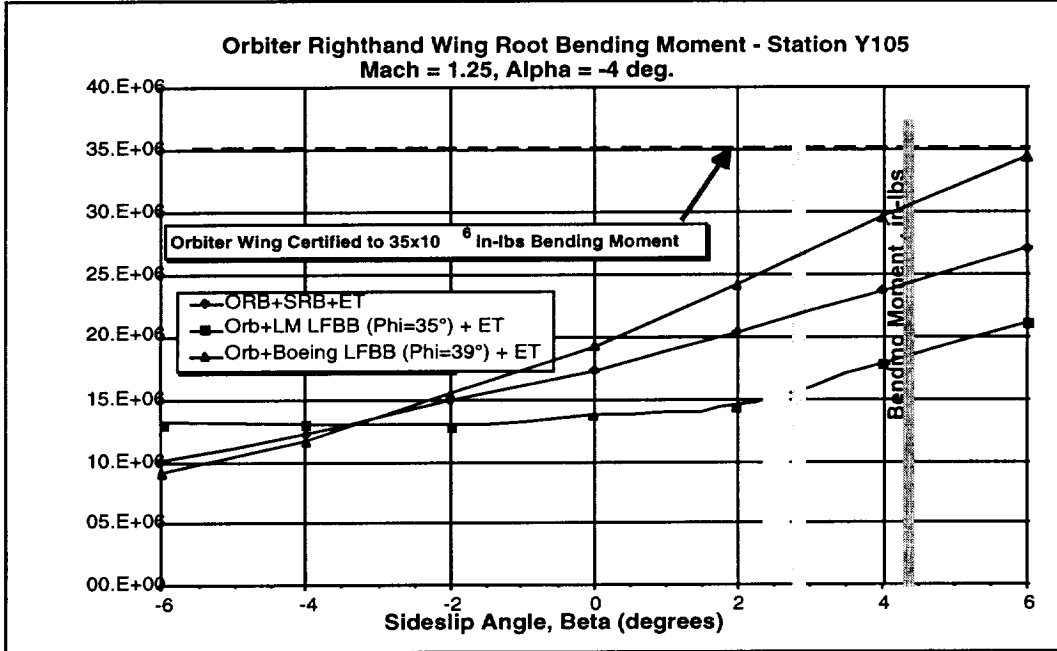

Figure 23. The February 1998 dual configuration meets orbiter requirements with margin as verified in wind tunnel tests in MSFC's Trisonic Wind Tunnel

The dual configuration has a number of design options, including use of canards, location of FBE's, and wing aspect ratio. One configuration that meets the requirements is shown in Figure 24. It features 35° swept fixed wings located far aft to protect the Orbiter wings. It also features equipment locations to drive the center of gravity aft and fuselage shaping to pull the center of pressure forward to limit the stability of the configuration. The landing

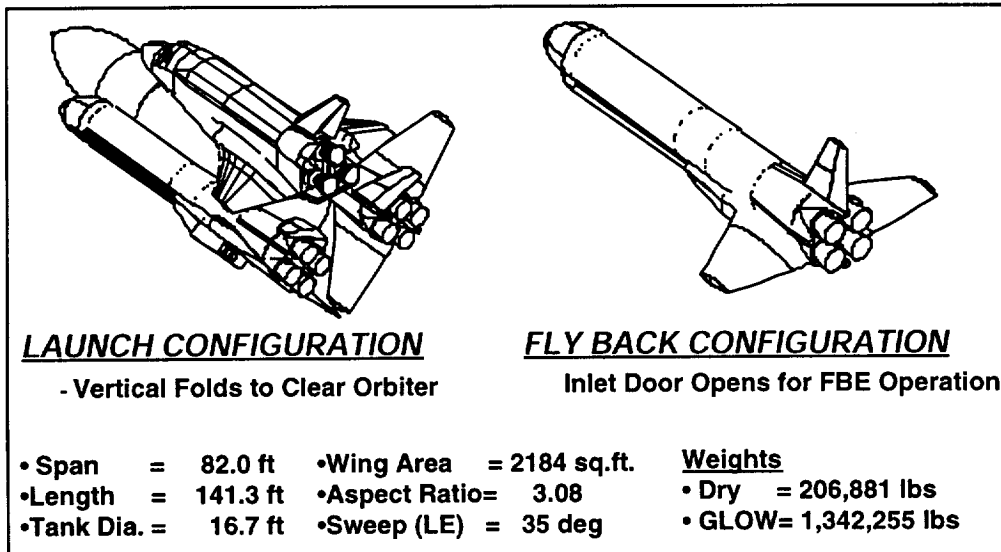

Figure 24. The dual configurations meet ascent and flyback requirements

gear is configured for landings only, with transportation being on the Shuttle carrier aircraft.

The catamaran configuration (Figure 25) is a twin fuselage configuration with 45° LE sweep outboard delta wings and a straight center section. The FBE's are mounted internally in the nose, behind a retractable "sugar scoop" intake, which gives a deployed configuration very similar to the efficient A-7 and F-8 aircraft intakes.

The configuration presently shows a forward "spreader bar," but dynamic flight control analysis indicates that it is not required, and we expect to delete it on the next baseline update. The catamaran fuselage is slightly offset from the SRB centerlines, but analysis shows the revised ET forward attach reactions are within the ET envelope. The rolling load of the booster fuselage caused by the wing is reacted in the center wing, and this, plus a new optimized aft strut arrangement, is expected to reduce the aft ET attach loads.

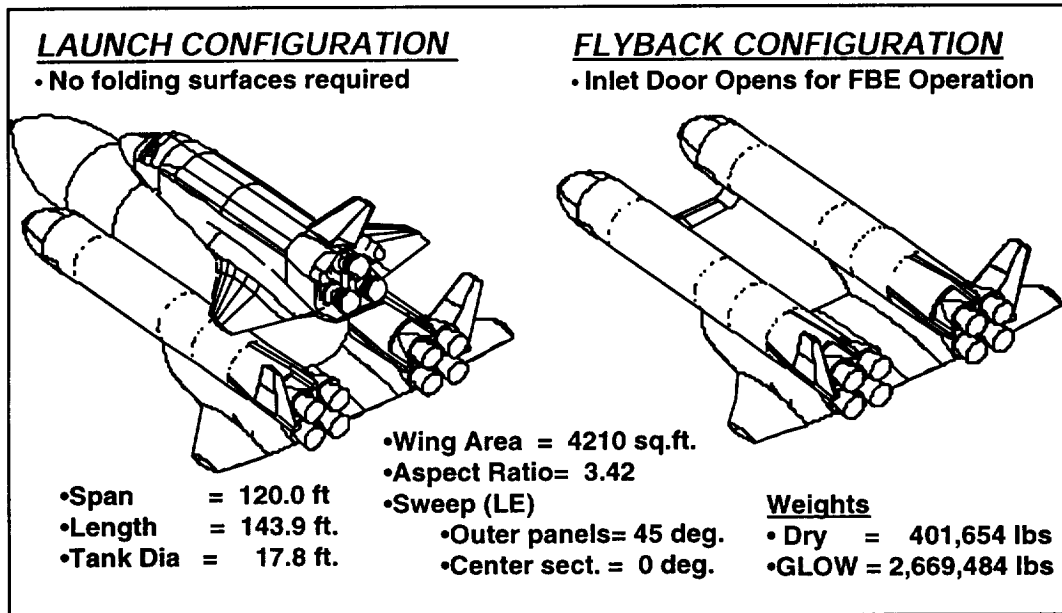

Figure 25. The catamaran configuration meets all program requirements with margin for optimization

SUMMARY AND CONCLUSIONS

The concept of LFBB for the Shuttle system is technically feasible. The LFBB's offer the potential for significant benefits to the Shuttle program as noted on Figure 26. These include benefits in the areas of safety, performance, mission effectiveness and cost.

With the LFBB, the Space Shuttle becomes an extremely competitive, heavy lift, manned launch system for the next several decades. The LFBB also opens up the possibility of being a first stage for future very heavy lift vehicles, or possibly two stage to orbit fully reusable systems. In summary, the concept is feasible and the benefits are significant (Figure 27).

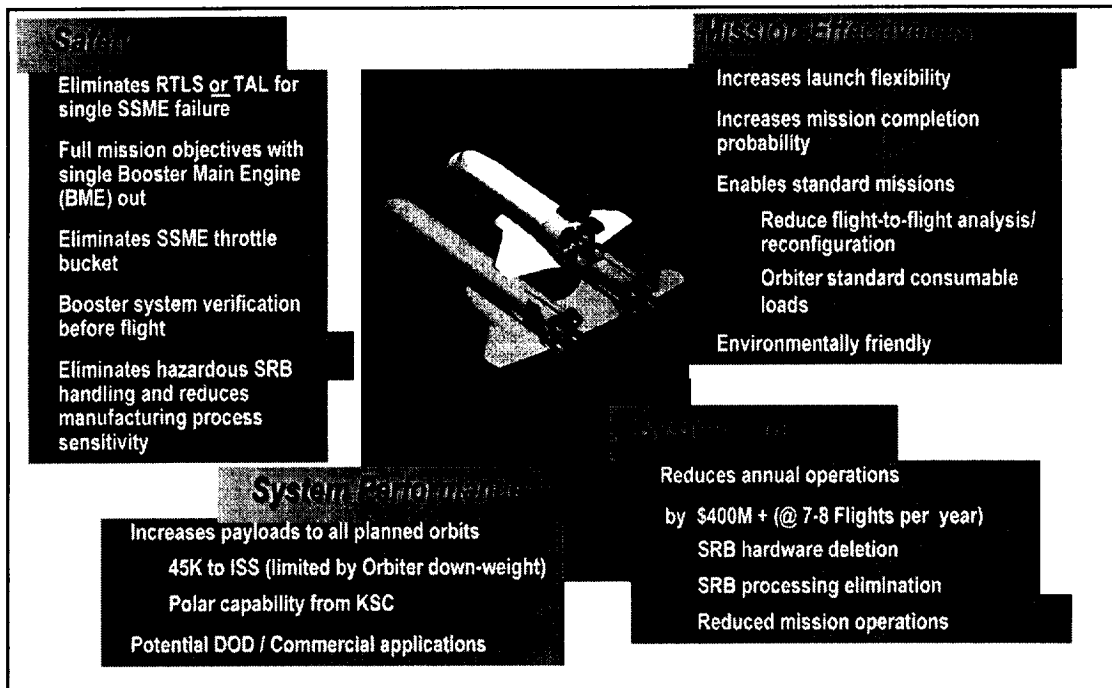

Figure 26. Liquid Fly-Back Booster - Potential significant benefit to Shuttle

A Possible Shuttle Upgrade --

Space Shuttle Vehicle with
Liquid Fly Back Boosters

- **Concept is feasible**

and

- **Benefits are significant**

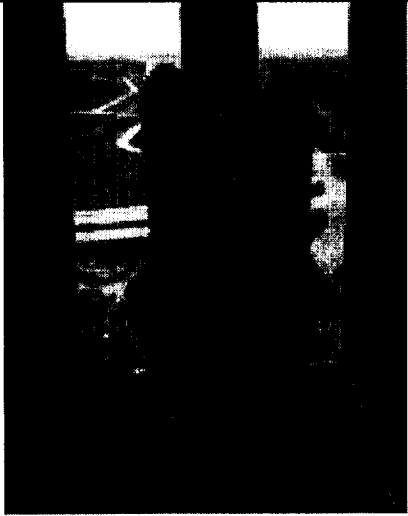

Figure 27. In Summary

REFERENCES

1. Kaplan, J., W. von Braun, et al. Across the Space Frontier. New York: The Viking Press (1952)
2. Smith, E.P. Space Shuttle in Perspective - History in the Making. AIAA-75-336. Washington, D.C.: American Institute of Aeronautics and Astronautics Annual Meeting and Technical Display, 11th (February 24-26, 1975)
3. Scott, H. A. Space Shuttle Orbiter Configuration Case History. AIAA-78-1469. New York: American Institute of Aeronautics and Aerospace (1978)
4. Thompson, R. F. Von Karman Lecture: The Space Shuttle - Some Key Program Decisions. AIAA-84-0574. New York: American Institute of Aeronautics and Aerospace (1984)
5. Morita, W. J., Bell, M. W. J. Shuttle Growth Study - Final Report - Contract NAS8-32015. Downey, California: Rockwell International, SD77-SR-0008 (1977)
6. Wear, L.O. Liquid Rocket Boosters for Space Shuttle. AIAA-89-2622. Monterey, California: 25th Joint Propulsion Conference AIAA/ASME/SAE/ASEE (July 10-12, 1989)
7. Biala, P. and Simon, M. C. The Liquid Rocket Booster as an Element of the U.S. National Space Transportation System. IAF-89-294. Malaga, Spain: 40th Congress of the International Astronautical Federation (October 8-14, 1989)
8. Benton, M. G. "Reusable Flyback Liquid Rocket Booster for the Space Shuttle," Journal of Space Craft and Rockets, Vol. 26, No. 4 (July/August 1989)
9. Faget, M.A. and Smith, O.G. Potential Improvements to the Shuttle Through Evolution. AIAA-93-2417. Monterey, California: 29th Joint Propulsion Conference AIAA/SAE/ASME/ASEE (June 28-30, 1993)
10. Green, J. H. Vision 2030: Shuttle Evolution for Post-2000 Operations. AIAA-93-4059. Huntsville, Alabama: AIAA Space Programs and Technologies Conference and Exhibit (September 21-23, 1993)
11. Greene, J. H. A Flyback Liquid Booster Concept for Shuttle and Future U.S. Launch Vehicles. AIAA-94-4600. Huntsville, Alabama: AIAA Space Programs and Technologies Conference (September 27-29, 1994)
12. Peterson, W., et al. "Liquid Flyback Booster Pre-Phase A Study Assessment", Vol 1 and Vol 2, NASA Technical Memorandum TM/04801 (September 1994)
13. Smelser, J. W. LFBB Feasibility Assessment Study - Interim Report. Briefing to Shuttle Upgrades Program Review Control Board (PCRB) at Johnson Space Center (March 24, 1998)