



US005633975A

**United States Patent** [19][11] **Patent Number:** **5,633,975**

Gary et al.

[45] **Date of Patent:** **May 27, 1997**[54] **SECURITY SYSTEM RESPONSIVE TO OPTICAL FIBER HAVING BRAGG GRATING**[75] Inventors: **Charles K. Gary**, Palo Alto; **Meric Ozcan**, Sunnyvale, both of Calif.[73] Assignee: **The United States of America as represented by the Administrator of the National Aeronautics and Space Administration**, Washington, D.C.[21] Appl. No.: **572,396**[22] Filed: **Nov. 14, 1995**[51] Int. Cl.<sup>6</sup> ..... **G02B 6/124**[52] U.S. Cl. .... **385/147; 385/37; 385/12; 385/38; 70/DIG. 46; 250/227.14**[58] **Field of Search** ..... 385/147, 37, 16, 385/15, 38, 12; 250/227.14, 556; 356/71; 70/277, 278, DIG. 51, DIG. 46[56] **References Cited****U.S. PATENT DOCUMENTS**

3,728,521	4/1973	Borough et al.	.....	235/61.112
3,733,862	5/1973	Killmeyer	.....	70/277
3,769,514	10/1973	Clark, Jr.	.....	250/341

3,797,936	3/1974	Dimitriadis	.....	356/71
4,079,605	3/1978	Bartels	.....	70/277
4,286,305	8/1981	Pilat et al.	.....	361/172
4,369,481	1/1983	Early	.....	361/173
4,447,123	5/1984	Page et al.	.....	350/96.24
4,725,110	2/1988	Glenn et al.	.....	350/3.61
5,351,324	9/1994	Forman	.....	385/37

*Primary Examiner*—Phan T. H. Palmer  
*Attorney, Agent, or Firm*—Kenneth L. Warsh; Harry Lupuloff; John G. Mannix

[57] **ABSTRACT**

An optically responsive electronic lock is disclosed comprising an optical fiber serving as a key and having Bragg gratings placed therein. Further, an identification system is disclosed which has the optical fiber serving as means for tagging and identifying an object. The key or tagged object is inserted into a respective receptacle and the Bragg gratings cause the optical fiber to reflect a predetermined frequency spectra pattern of incident light which is detected by a decoder and compared against a predetermined spectrum to determine if an electrical signal is generated to either operate the lock or light a display of an authentication panel.

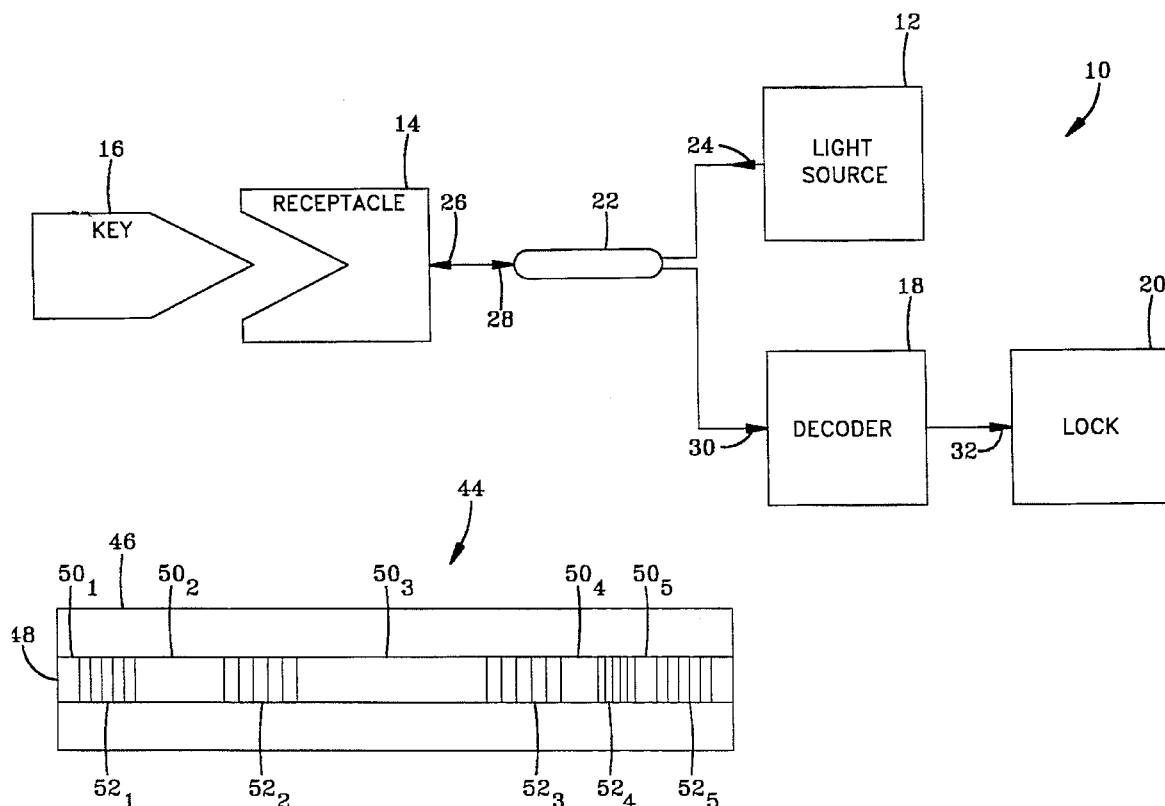
**10 Claims, 5 Drawing Sheets**

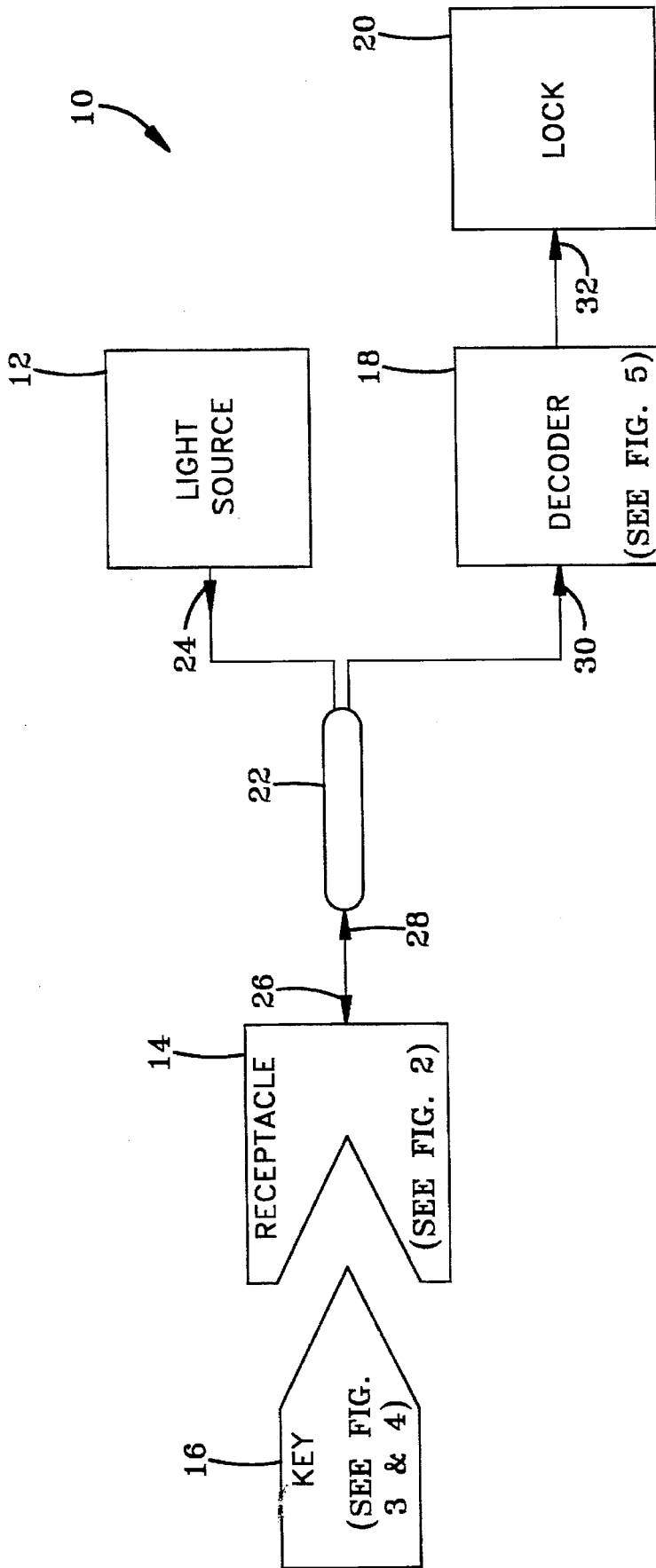

FIG-1

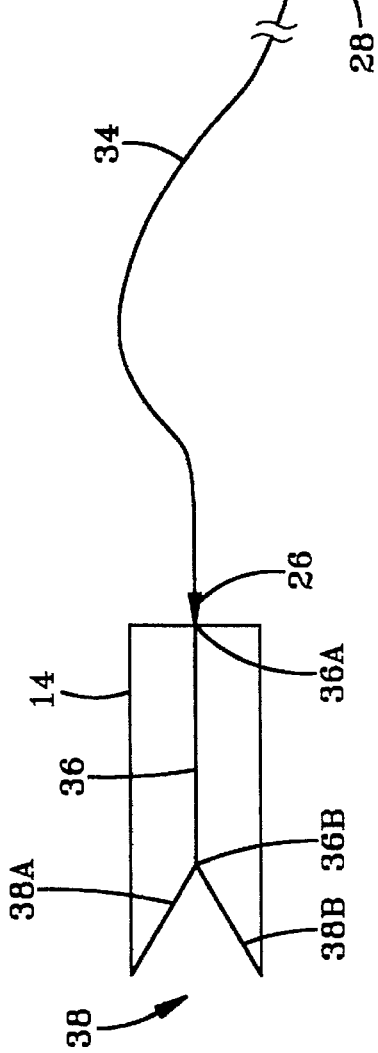
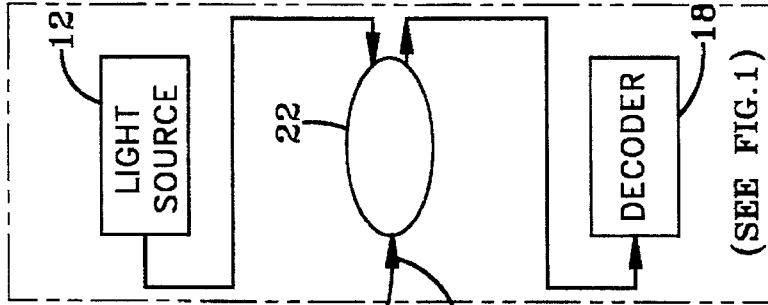
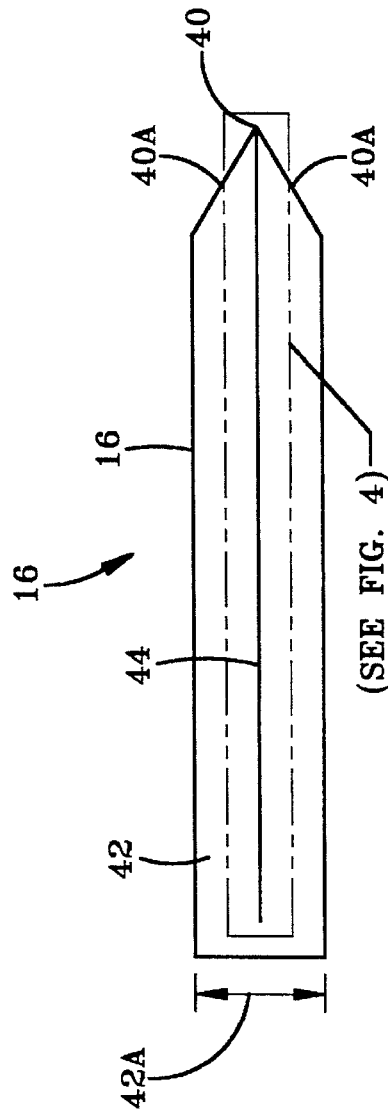

FIG-2



(SEE FIG. 4)

FIG-3

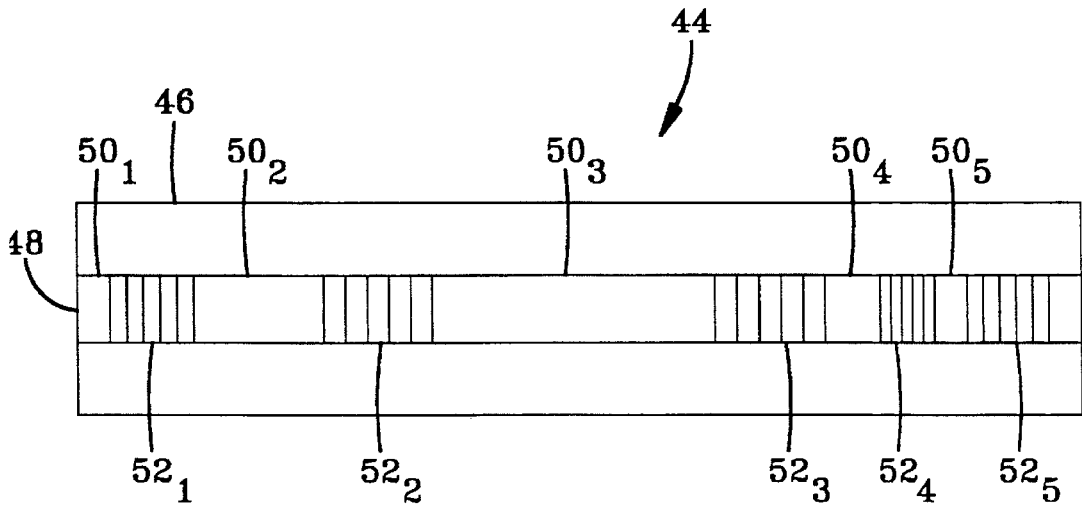

FIG-4

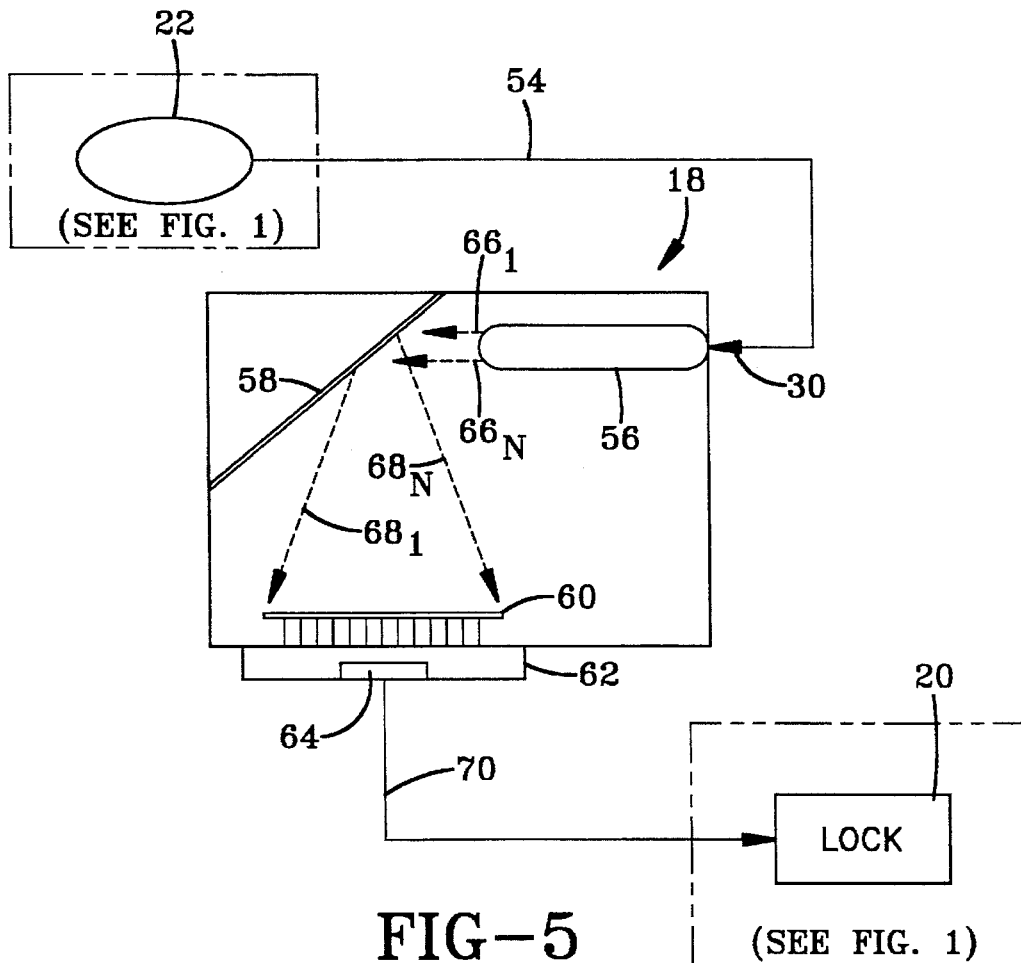

FIG-5

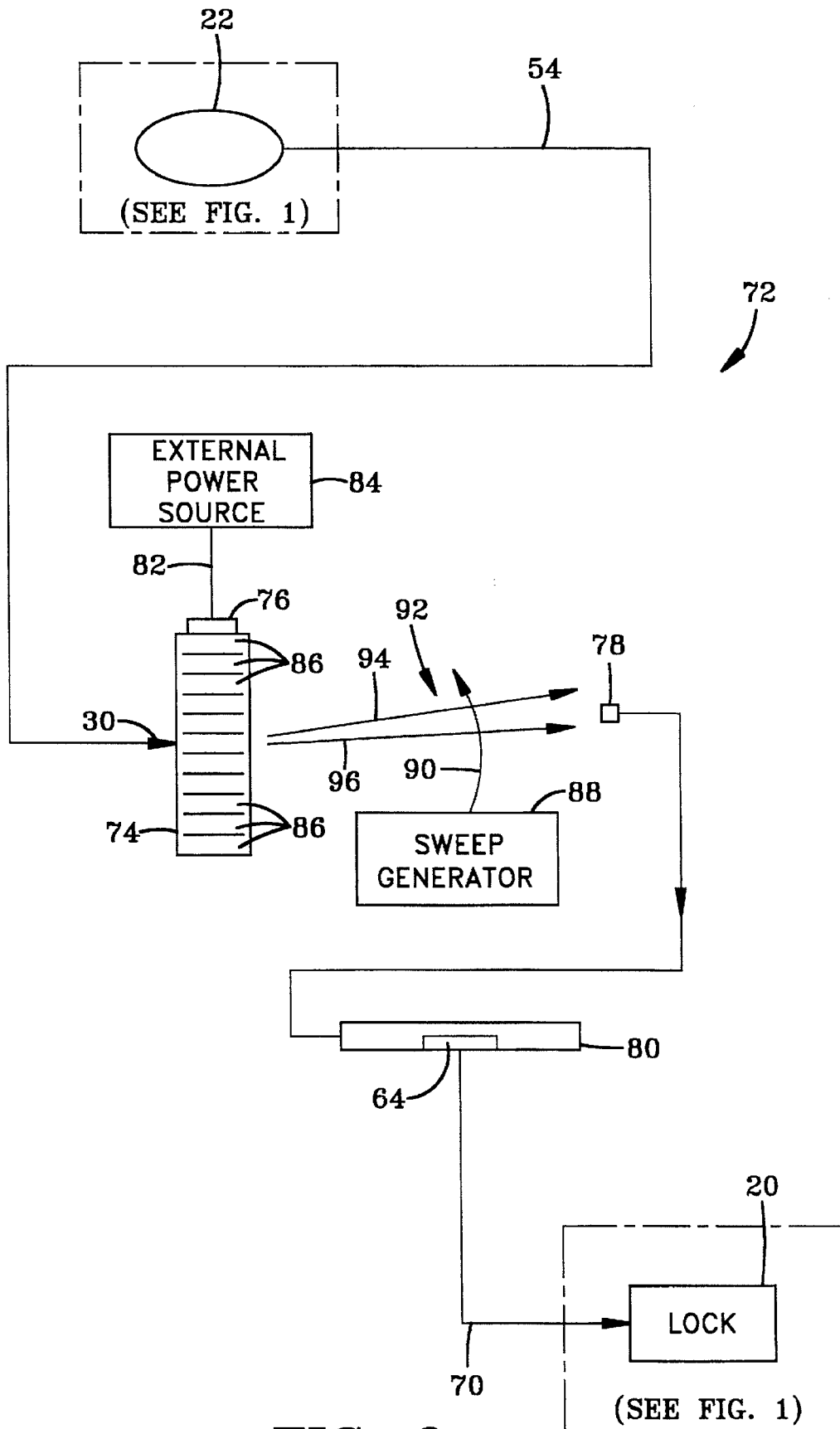

FIG-6

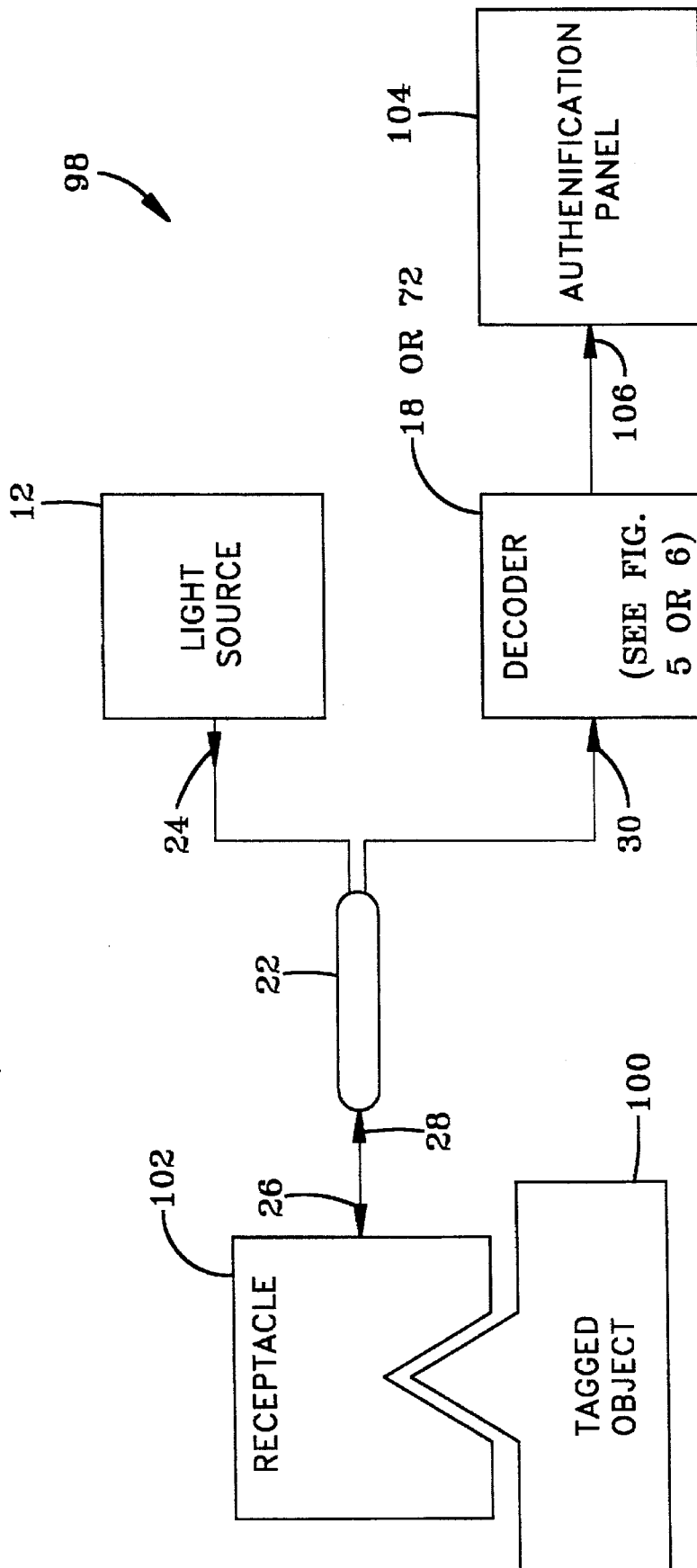

FIG--7

## SECURITY SYSTEM RESPONSIVE TO OPTICAL FIBER HAVING BRAGG GRATING

### ORIGIN OF THE DISCLOSURE

The invention described herein was made in the performance of work under a NASA contract and is subject to the provision of Section 305 of the National Aeronautics and Space Act of 1958, Public Law 85-568 (72 Stat. 435; 42 U.S.C. 2457).

### BACKGROUND OF THE INVENTION

#### 1. Technical Field of the Invention

The present invention relates to a security system comprising an optical fiber serving as a key and having a Bragg gratings that provide for reflected light with a predetermined frequency spectrum which is detected and compared by a decoder to control the locking/unlocking of a locking mechanism.

#### 2. Description of the Prior Art

Security systems comprising light sources, optical fibers having Bragg gratings, and electronic devices to detect for the predetermined frequency spectra reflected by the Bragg gratings are known, and one such system is described in U.S. Pat. No. 5,351,324 ('324), herein incorporated by reference. The '324 patent discloses an optical fiber placed in a container and located along the seals of the container so that if any one of the seals is disturbed or broken, the optical fiber is correspondingly disturbed or broken and its reflected frequency spectra is altered which is detected by the electronic devices to ascertain a security breach. The '324 patent, although serving well the needs of security for a container, does not address the needs of other users, such as an electronic lock used for industrial and domestic purposes and operated by an associated key.

Security systems using optical devices are also known and some of which are described in U.S. Pat. Nos. 4,079,605 ('605) and 4,369,481 ('481) and both of which are herein incorporated by reference. The '605 patent uses a card device to operate an electronic lock, whereas the '481 patent uses a key having reflective surfaces to operate an electronic lock. Whereas the card of the '605 patent is convenient in many ways, it does have a drawback in that it must be kept on person, such as in the wallet, and thus may be misplaced (not on the person) when actually needed. The key of the '481 patent although not normally being subjected to being misplaced, does have a drawback in that it requires the complementary lock receptacle to coact with light reflected off the surfaces of the key. This coaction limits one key to one receptacle, thereby, preventing one key to be used for multiple applications. It is desired that other types of key means be employed for optically operated electronic locks that allows for greater flexibility and convenience in their usage.

Accordingly, it is a primary object of the present invention to provide a key for optically responsive electronic locks that is convenient to use for multiple applications and which is not susceptible to being misplaced so that it may be used when needed.

It is yet another object of the present invention to provide a key for an optically responsive electronic lock that is formatted into unique patterns that are not easily duplicated, yet are easily verifiable for identification purposes.

It is still further an object of the present invention to provide for an optically responsive electronic lock having decode means that are commercially available so that the

associated lock may be more economically acceptable by the industrial and domestic users.

### SUMMARY OF THE INVENTION

The present invention is directed to a security system comprising an electronic lock having means that are responsive to a fiber optic serving as a key thereof.

The security system comprises a light source, a receptacle, a key, and a decoder. The light source has means for providing light along a predetermined path. The receptacle has a mouth with predetermined dimension and a passageway with entrance and exit portions and located to intercept the light. The key comprises a carrier and a fiber optic. The carrier has an external portion with dimensions complementary to the exit portion of the passageway and the fiber optic is located in the carrier to intercept the light at the exit portion of the passageway. The fiber optic has at least one reflective Bragg grating that reflects the intercepted light into a predetermined spectral pattern. The decoder has means for receiving and decoding the reflected predetermined spectral pattern and compares and generates an electrical signal when the predetermined spectral pattern matches a preselected pattern.

### BRIEF DESCRIPTION OF THE DRAWINGS

FIG. 1 is a block diagram of the optical responsive electronic lock of the present invention.

FIG. 2 illustrates the general features of the receptacle of the present invention.

FIG. 3 illustrates the general features of the key of the present invention.

FIG. 4 illustrates details of the fiber optic embedded in the key of FIG. 4.

FIG. 5 illustrates one embodiment of the decoder of the present invention.

FIG. 6 illustrates another embodiment of the decoder of the present invention.

FIG. 7 is a block diagram of an identification system of the present invention.

### DETAILED DESCRIPTION OF THE PREFERRED EMBODIMENTS

With reference to the drawings, wherein the same numerals indicate the same elements throughout, there is shown in FIG. 1 a block diagram of the optically responsive electronic lock 10 of the present invention. The electronic lock 10 is responsive to a light source 12 and comprises a receptacle 14 that accepts a key 16 having at least one Bragg grating therein with a known frequency spectra created by reflecting incident light generated by the light source 12 which is detected by the decoder 18 and compared against a predetermined spectrum and, if the comparison agrees, generates an electrical signal which, in turn, unlocks the lock 20. The electronic lock 10 further comprises a coupler 22, known in the field, for transferring and directing light among the light source 12, the receptacle 14, and the decoder 18.

In general, the light source 12 generates light which is conveyed in the direction indicated by arrow 24 to the optical coupler 22 which, in turn, directs the light in the direction indicated by arrow 26 to the receptacle 14. The receptacle 14, in cooperation with the key 16, reflects light in the direction indicated by arrow 28 back to the coupler 22 which, in turn, directs the light, as indicated by arrow 30, to the decoder 18. The decoder 18 decodes the reflected light

and if the reflected light is proper, that is, it has a predetermined spectra pattern, the decoder 18 provides an electrical signal to the lock 20 in the direction indicated by arrow 32.

The light source 12 preferably comprises a semiconductor device, such as a light-emitting diode that emits visible or infrared light when forward biased. The light source 12 emits broad band light that is directed along a predetermined path to the receptacle 14 which may be further described with reference to FIG. 2.

As seen in FIG. 2, the light from the light source 12 is directed from the coupler 22 to the receptacle 14 by way of a conventional fiber cable 34 which confines the light to the predetermined path. The receptacle 14 has a passageway 36 for conveying light, with an entrance portion 36A and an exit portion 36B. The passageway 36 is located so as to intercept the light emitted from light source 12 and flowing out of fiber cable 34 in a direction indicated by arrow 26. The receptacle 14 has a mouth 38 with predetermined dimensions and in one embodiment includes oppositely sloped sidewalls 38A and 38B. The mouth 38 may have other configurations so long as its predetermined dimensions are complementary to those of the key 16 which may be further described with reference to FIG. 3.

As seen in a comparison between FIGS. 2 and 3, the key 16 has a head 40 with oppositely sloped sidewalls 40A and 40B which are complementary to sloped sidewalls 38A and 38B, respectively, of mouth 38. The head 40 is actually a part of a carrier 42 which has lodged therein a fiber optic 44 located so as to intercept light at the exit portion of the passageway 36B of receptacle 14 when the head 40 of the carrier 42 is inserted into the mouth 38 of the receptacle 14. The fiber optic 44 is a relatively thin device having a typical diameter of 125 micrometers and extremely small, as little as 0.01 cm<sup>3</sup>. The fiber optic 44 because of its small and fragile nature, and its need to serve somewhat rugged use, is preferably encased in the carrier 42 to provide protection thereof and to serve as a rugged key 16.

The carrier 42 may be comprised of metal and have a diameter 42A, as shown in FIG. 3, of approximately two millimeters. The carrier 42 having the optic fiber 44 lodged therein may be of any shape, allowing it to take the form of everyday objects, such as a tie clip, pen, jewelry or any other object that is normally kept on the person. The key 16, comprising the carrier 42 and fiber optic 44, may be more readily fastened, or become a more or less natural part of a person's everyday attire, so as to avoid the misplacement problem discussed in the "Background" section for a conventional card serving as a key device. Furthermore, the key 16 is much easier to conceal than magnetic cards or large reflective optical surfaces serving as key devices which are usually removed from the clothing of a person as soon as possible because of their somewhat bulky and inconvenient physical characteristics. The fiber optic 44, unlike bulky devices, because of its relatively small dimensions would be placed by itself, or an appropriate carrier, into a wristwatch thereby further assuring its availability when needed. The optic fiber 44 may be further described with reference to FIG. 4.

The optic fiber 44 comprises cladding 46 that is placed on a core 48. The core 48 comprises zones 50<sub>1</sub>, 50<sub>2</sub>, 50<sub>3</sub>, 50<sub>4</sub>, and 50<sub>5</sub> which have smooth surfaces and are devoid of any Bragg gratings and provide for zero spectra lines, whereas zones 52<sub>1</sub>, 52<sub>2</sub>, 52<sub>3</sub>, 52<sub>4</sub>, 52<sub>5</sub> of core 48 do have Bragg gratings and provide for predetermined spectral lines so as to provide for a predetermined reflective spectra pattern. The Bragg gratings 52<sub>1</sub>, 52<sub>2</sub>, 52<sub>3</sub>, 52<sub>4</sub>, and 52<sub>5</sub> may be placed

into the core 48 in any known manner, such as the procedure for inducing optical gratings, more fully described in U.S. Pat. No. 4,725,110, herein incorporated by reference.

The core 48 having a Bragg grating such as 52<sub>1</sub>, 52<sub>2</sub>, 52<sub>3</sub>, 52<sub>4</sub>, or 52<sub>5</sub>, as well known in the art, is treated as a special optical fiber whose index of a fraction changes periodically. The Bragg gratings 52<sub>1</sub>, . . . 52<sub>5</sub>, reflect light at a frequency corresponding to the period of the index of refraction changes. By placing many Bragg gratings, such as 52<sub>1</sub> . . . 52<sub>N</sub>, in a serial arrangement, the light from the light source 12 that the core 48 intercepts as the light emanates from the exit portion 36B of receptacle 14, is reflected as light consisting of multiple spectral lines corresponding to the wavelength of the individual Bragg gratings 52<sub>1</sub> . . . 52<sub>5</sub>. Such an arrangement allows for a binary number to be placed in the key 16, more particularly, core 48 by the presence or absence of each of a sequence of spectral lines. The coded core 48 reflects light, originated from light source 12, back to the coupler 22 which, in turn, as seen in FIG. 5, is conveyed back to the decoder 18 via the optical fiber 54. The decoder 18 may be further described with reference to FIG. 5 illustrating a plurality of elements given in Table 1.

TABLE 1

REFERENCE NO.	ELEMENT
56	COLLECTING OPTICS
58	DIFFRACTION GRATING OPTICS
60	LINEAR DETECTOR ARRAY
62	CONTROL ELECTRONICS
64	SOLENOID

The collecting optics 56, in a manner known in the art, receive and focus the reflected predetermined spectra that has been generated by the coded core 48 into a beam comprising light rays 66<sub>1</sub> . . . 66<sub>N</sub> that is directed toward the diffraction grating optics 58.

The diffraction grating optics 58, may be those such as known in the art, comprising a transparent plate containing a plurality of parallel lines, grooves or slits. The light rays 66<sub>1</sub> . . . 66<sub>N</sub> pass through, for example, the slits and produce a spectrum as a result of interference patterns and which spectrum is comprised of light rays 68<sub>1</sub> . . . 68<sub>N</sub>, each of a known wavelength, which strike the linear detector array 60.

Each of the light rays 68<sub>1</sub> . . . 68<sub>N</sub> diffracted from the diffraction grating optics 58 is at a unique angle so that the spectra lines of the light 68<sub>1</sub> . . . 68<sub>N</sub> created by the coded core 48 reflecting the light generated by the light source 12, all strike or impinge the linear detector array 60 at unique locations. In a manner known in the art, the linear detector array 60 produces an electrical signal at those impinged locations where light is present, thus, an electrical signal is generated for each spectral line present in the key, more particularly, created by the Bragg gratings 52<sub>1</sub> . . . 52<sub>N</sub> of the coded core 48. Each of the generated electrical signals may be representative by a binary bit so that the cumulative output of the linear detector array 60 represents a binary number (digital word). The linear detector array 60 produces the binary number that is routed to the control electronics 62.

The control electronics 62 comprises a comparison means for comparing the binary number of the linear detector array 60 against a preselected pattern, represented by a binary number, and generates an electrical signal when the binary output signal matches the preselected pattern. The electrical signal (not shown) is directed to a solenoid 64.

The solenoid 64 may be of the conventional type, such as that described in the previously mentioned U.S. Pat. No.



4,369,481. The solenoid **64** controls the electronic lock **20**, via path **70**, allowing it to be moved into a latched or unlatched position which, in turn, allows for an associate door, or other security device being serviced by the lock **20**, to be opened or closed in a manner known in the art. Although solenoid **64** serves well its intended function, the electrical signal generated by the control electronics **62** can be used to drive other locking mechanisms, including things other than solenoids, such as piezoelectric devices.

An alternate embodiment of a decoder **72** that employs acoustical optic devices is illustrated in FIG. 6 and comprises a plurality of elements given in Table 2.

TABLE 2

REFERENCE NO.	ELEMENT
74	ACOUSTOOPTIC CRYSTAL
76	ELECTROACOUSTIC TRANSDUCER
78	PHOTODETECTOR
80	CONTROL ELECTRONICS

The acoustooptic crystal **74** is arranged to intercept the predetermined spectrum pattern reflected by the coded core **48**, but to allow this pattern to find its way through the acoustooptic crystal **74**. An electrical signal **82**, from an external power source **84**, is converted to an ultrasonic vibration **86**, illustrated by vertical bars representative of an acoustic wave within the acoustooptic crystal **74**, by the transducer **76**. As the predetermined spectrum pattern passes through the acoustic wave **86**, it is diffracted with an angle determined by the product of the wavelength (frequency) of the predetermined spectrum pattern and the frequency of the acoustic wave **86**. The electrical, and thus acoustic, frequency is swept by means of a sweep generator **88**, known in the art, in a direction indicated by directional arrow **90** through a range so that at given points in time, each wavelength of input light spectrum **92**, shown in FIG. 6 by arrows **94** and **96** exiting from the acoustooptic crystal **74**, is diffracted and directed to the photodetector **78**. This diffraction produces a voltage on the photodetector **78** that varies in time with the same pattern as the predetermined spectrum pattern applied to the decoder **72**, via the fiber cable **54**. The time varying signal may serve as a binary output signal similar to that produced by the linear detector array **60** of FIG. 5. The sweep time of the sweep generator **88** for the full frequency of the light spectrum **92** is typically 100 milliseconds or less, so that once the key **16** of FIG. 3 is inserted into the receptacle **14** of FIG. 2 it is unlikely to be removed before proper identification can be made by the embodiment of FIG. 6, having the photodetector **78** which generates a time varying signal that is applied to the control electronic **80**.

Control electronics **80** converts the time varying signal to a digital code for the key **16** in the same way that the control electronics **62** of FIG. 5 converts the output of the linear detector array **60** to a digital code. The control electronics **80** generates an electrical which is routed to the solenoid **64** which, via signal path **70**, controls the lock **20**. The solenoid **64** and the lock **20** operates in a manner as previously described with reference to FIG. 5.

#### OPERATION OF THE OPTICALLY RESPONSIVE ELECTRONIC LOCK OF THE PRESENT INVENTION

The optically responsive electronic lock **10** of FIG. 1 is rendered operative by first inserting the key **16** into the

receptacle **14**. The coded core **48** (see FIG. 4) of the key **16** intercepts the light generated by light source **12** and exiting the exit portion **36B** of receptacle **14** (see FIG. 2). The coded core **48**, having the preselected Bragg gratings, reflects the incident light into a predetermined spectra pattern which is compared by either the decoder **18** of FIG. 5 or the decoder **72** of FIG. 6. The decoder **18** or **72** has a prestored binary number representative of a preselected spectra pattern to which the decoder **18** or **72** compares the predetermined spectra pattern created by the coded core **48**. If the reflected predetermined spectra pattern agrees with the preselected spectra pattern then the contents of the key **16** is authenticated which, in turn, causes the decoder **18** or **72** to generate an electrical signal which operates a solenoid which, in turn, unlocks the lock **20**.

The Bragg gratings of the coded core **48** may be selected to provide numerous (e.g., 65,536) identification codes. The coded core **48**, more exactly the fiber optic **44** of FIG. 4, because of its small size may be conveniently housed by the carrier **42** (see FIG. 3). The carrier **42**, in turn, may be conveniently shaped to more readily accommodate the usage of the key **16**. For example, the carrier **42** may be formed as part of a tie clip or pen. This is normally more easily carried by a user and therefore are less susceptible to being misplaced and more likely to be available when needed.

The fiber optic **44** because of its multiple identification codes may be selectively formatted to accommodate and activate multiple locks for various security applications. Further, the fiber optic **44** because of its relatively small dimensions is not easily duplicated which further enhances its security parameters.

Because of the fiber optic **44** capability to operate multiple locks and because a single lock can be operated by multiple fiber optics **44**, one arrangement of the fiber optic **44** may easily serve as a master key that operates on a group of locks, while other arrangements of the fiber optic **44** serve as a key that operates just one of the locks of the group.

Although the previously given description has been primarily related to a security system operating locks, the present invention is equally applicable to an identification system **98** that may be further described with reference to FIG. 7.

The identification system **98** includes elements **12**, **18**, **22** and **72** and the informational exchange indicated by directional arrows **24**, **26**, **28** and **30** all of which have been previously described with reference to FIGS. 1-6. The identification system **98** further includes a tagged object **100**, a receptacle **102** and an authentication panel **104** which is responsive to a signal routed in the direction indicated by arrow **106** and generated by either the decoder **18** or **72**.

The identification system **98** operates in a manner quite similar to the security system **10** of FIG. 1, with the exception that instead of the fiber optic **44** of FIGS. 3 and 4 serving as the key **16** of FIG. 1, the fiber optic **44** serves as a tag for tagged object **100** to be identified and authenticated by system **98**. For instance, the fiber optic **44** could be placed in expensive original products comprising the tagged object **100**, such as limited edition lithographs to verify their identity. The tagged object **100** is then positioned to mate with the receptacle **102** with the exception that the physical features of the receptacle **102** needs to be selected to accommodate the mating of the tagged object **100**.

The tagged object **100** and the receptacle **102** respectively operate in a manner as previously described for the key **16** and receptacle **14** of FIGS. 1-6. Furthermore, the selected

decoders 18 and 72 operate in a manner as previously described for FIGS. 5 and 6, respectively, with the exception that the solenoid 64, or its equivalent, is no longer needed to operate a locking mechanism, but rather the selected decoder 18 or 72 now supplies an electrical signal that is routed in direction 106 to the authentication panel 104 which, in turn, may respond with an appropriate display to indicate the proper authentication.

It should now be appreciated that the practice of the present invention provides for an identification system as well as a security system both responsive to fiber optics that may be coded by means of Bragg gratings to provide for numerous identification codes that are not easily duplicated, yet are simply recognized.

It should be further appreciated that the fiber optics need only be conveniently inserted into a key, tagged object or some other insertable device that is matched with an appropriate receptacle and either authentication or security functions are performed by the practice of the present invention.

It should be still further appreciated that the fiber optics may be lodged into a convenient carrier, such as in the form of a tie clip pen or wristwatch, that is more readily available for use to operate an electronic lock.

Furthermore, it should be appreciated that the optical electronics for decoding the spectrum patterns created by the fiber optic are conventional in nature and therefore are readily available for the implementation of the system described herein and, therefore, may enter commerce more readily.

Further, although the invention has been described relatively to the specific embodiments thereof, it is not so limited and many modifications and variations thereof now will be readily apparent to those skilled in the art in light of the above teachings.

What we claim is:

1. A system comprising:

- (a) a light source having means for providing light along a predetermined path;
- (b) a receptacle having a mouth with predetermined dimensions and a passageway having entrance and exit portions, said passageway located so as to intercept said light;
- (c) a device insertable into said receptacle comprising:
  - (i) a carrier having an external portion with dimensions complementary to said mouth of said receptacle, and
  - (ii) a fiber optic located in said carrier so as to intercept said light at said exit portion of said passageway, said fiber optic having at least one reflective Bragg grating that reflects said intercepted light into a predetermined spectra pattern; and
- (d) a decoder having means for receiving and decoding said reflected predetermined spectra pattern and comparing and generating an electrical signal when said predetermined spectra pattern matches a preselected pattern.

2. The system according to claim 1, wherein said insertable device is a key.

3. The system according to claim 2 further comprising a solenoid switch that drives a locking device interconnected to a door and which solenoid is responsive to said electrical signal.

4. The system according to claim 1, wherein said insertable device is a tagged object.

5. The system according to claim 4 further comprising an authentication display panel which is responsive to said electrical signal.

6. The system according to claim 1, wherein said light source comprises a light emitting diode.

7. The system according to claim 1 further comprising a coupler for transferring and directing light energy among said light source, receptacle and decoder.

8. A system comprising:

- (a) a light source having means for providing light along a predetermined path;
- (b) a receptacle having a mouth with predetermined dimensions and a passageway having entrance and exit portions, said passageway located so as to intercept said light;
- (c) a device insertable into said receptacle comprising:
  - (i) a carrier having an external portion with dimensions complementary to said mouth of said receptacle, and
  - (ii) a fiber optic located in said carrier so as to intercept said light at said exit portion of said passageway, said fiber optic having a plurality of Bragg gratings that is arranged in series for intercepting said light and that reflects said intercepted light into a predetermined spectra pattern; and
- (d) a decoder having means for receiving and decoding said reflected predetermined spectra pattern and comparing and generating an electrical signal when said predetermined spectra pattern matches a preselected pattern.

9. A system comprising:

- (a) a light source having means for providing light along a predetermined path;
- (b) a receptacle having a mouth with predetermined dimensions and a passageway having entrance and exit portions, said passageway located so as to intercept said light;
- (c) a device insertable into said receptacle comprising:
  - (i) a carrier having an external portion with dimensions complementary to said mouth of said receptacle, and
  - (ii) a fiber optic located in said carrier so as to intercept said light at said exit portion of said passageway, said fiber optic having at least one reflective Bragg grating that reflects said intercepted light into a predetermined spectra pattern; and
- (d) a decoder having means for receiving and decoding said reflected predetermined spectra pattern and comparing and generating an electrical signal when said predetermined spectra pattern matches a preselected pattern, wherein said decoder comprises:
  - (i) optics for receiving and focussing said reflected predetermined spectra pattern into a beam;
  - (ii) diffraction grating optics arranged to intercept and allow said focussed reflected predetermined spectra pattern to pass therethrough as output signals thereof at predetermined angles;
  - (iii) a linear detector array arranged to intercept said output signals of said diffraction grating and develop a corresponding binary output signal; and
  - (iv) comparison means for comparing said binary output signal against said preselected pattern represented by binary bits and generating said electrical signal when said binary output signal matches said preselected pattern.

10. A system comprising:

- (a) a light source having means for providing light along a predetermined path;
- (b) a receptacle having a mouth with predetermined dimensions and a passageway having entrance and exit portions, said passageway located so as to intercept said light;

9

- (c) a device insertable into said receptacle comprising;
- (i) a carrier having an external portion with dimensions complementary to said mouth of said receptacle, and
  - (ii) a fiber optic located in said carrier so as to intercept said light at said exit portion of said passageway, said fiber optic having at least one reflective Bragg grating that reflects said intercepted light into a predetermined spectra pattern; and
- (d) a decoder having means for receiving and decoding said reflected predetermined spectra pattern and comparing and generating an electrical signal when said predetermined spectra pattern matches a preselected pattern, wherein said decoder comprises:
- (i) an acoustooptic crystal arranged with an electroacoustic transducer responsive to an applied electrical signal for developing an acoustic wave, said acoustooptic crystal being further arranged to intercept but allow said reflected predetermined spectra pattern to

10

- find its way therethrough so as to interact with said acoustic wave and be diffracted with an angle determined by the product of the wavelength, having a corresponding frequency, of said predetermined spectra pattern and the frequency of said acoustic signal;
- (ii) means for sweeping the frequency of said predetermined spectra pattern and the frequency of said acoustic wave to produce a time varying signal serving as a binary output signal; and
  - (iii) comparison means for comparing said binary output signal against said preselected pattern represented by binary bits and generating said electrical signal when said binary output signal matches said preselected pattern.

\* \* \* \* \*